

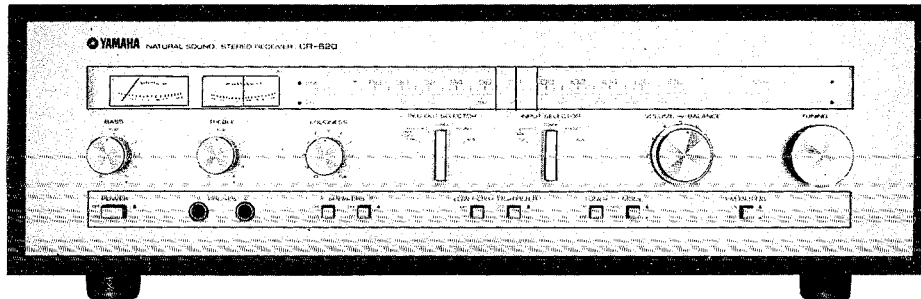

For more Hi-Fi manuals and set-up information  
please visit [www.hifiengine.com](http://www.hifiengine.com)

# CR-620

FM/AM STEREO RECEIVER



**YAMAHA**

REMARKS

R : GENERAL EXPORT MODELS

U : U.S.A MODELS

C : CANADIAN MODELS

A : AUSTRALIAN MODELS

B : BRITISH MODELS

E : EUROPEAN MODELS

# CONTENTS

PANEL OPERATION .....	2
SPECIFICATIONS .....	4
CHARACTERISTICS CHARTS .....	5
BLOCK DIAGRAM .....	6
DISASSEMBLY PROCEDURES	
FLOW CHART .....	7
PROCEDURES .....	7
DIAL CORD STRINGING .....	9
ADJUSTMENT	
ADJUSTING AMPLIFIER BOARD .....	10
ADJUSTING TUNER BOARD .....	11
CIRCUIT BOARD	
MAIN C. BOARD 2 & etc. ....	14
MAIN C. BOARD 1 .....	15
TUNER C. BOARD 1 .....	16
PACKAGE .....	17
SCHEMATIC DIAGRAM BY EXPORT ZONE .....	18
SCHEMATIC DIAGRAM .....	19
WIRING .....	20

# PANEL OPERATION

## FRONT PANEL

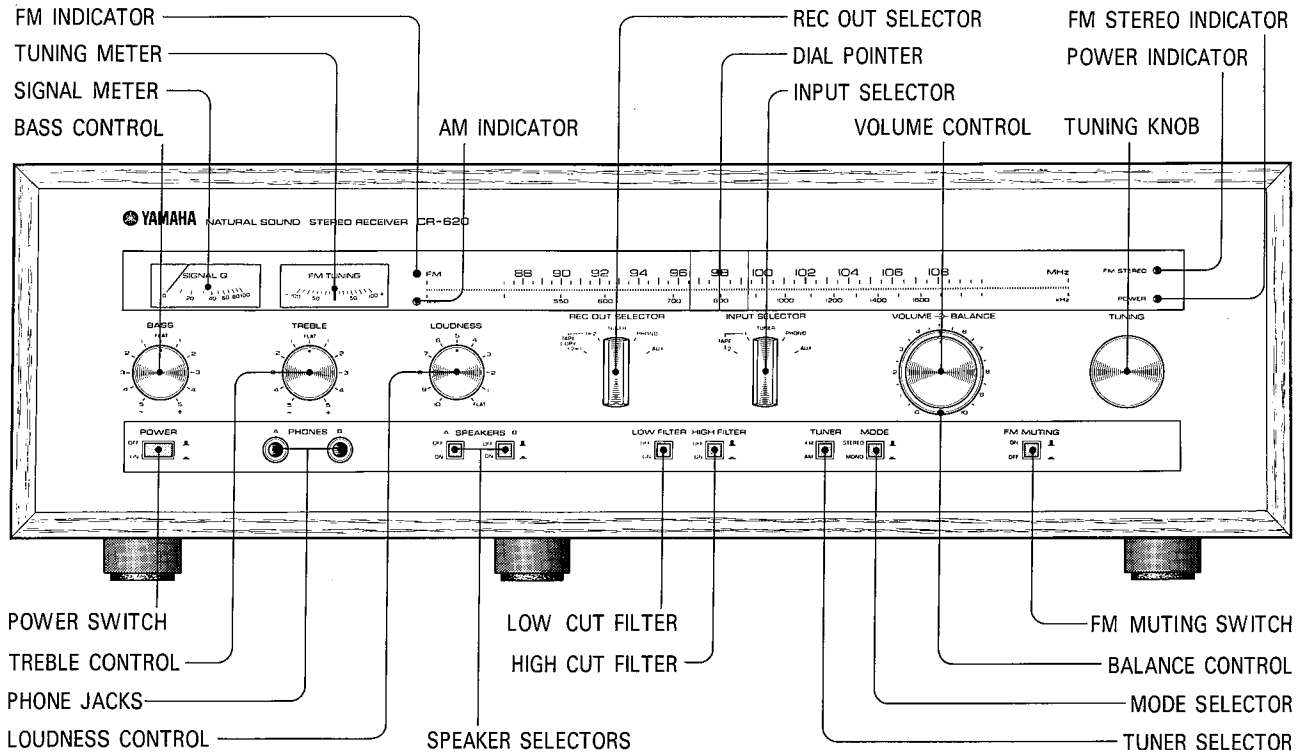

## REAR PANEL GENERAL MODEL

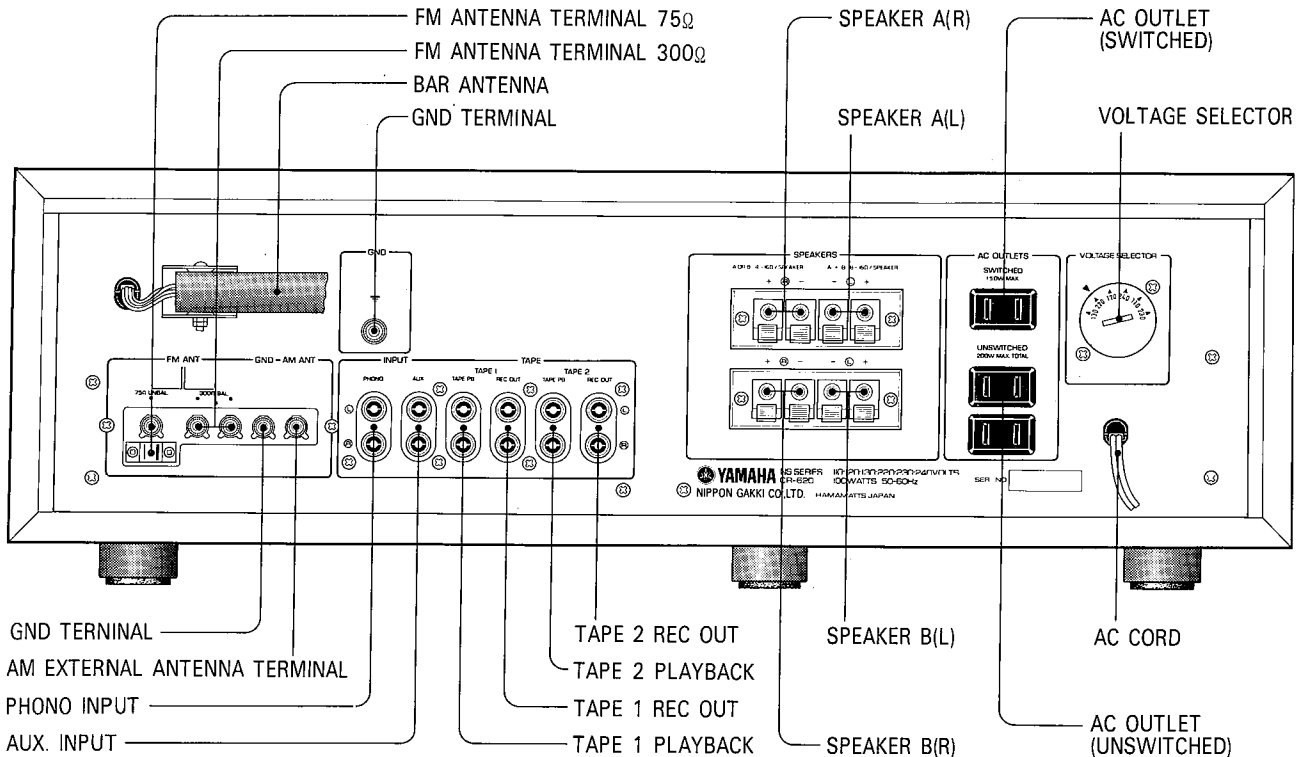

# PANEL OPERATION

## REAR PANEL US & CANADIAN MODEL

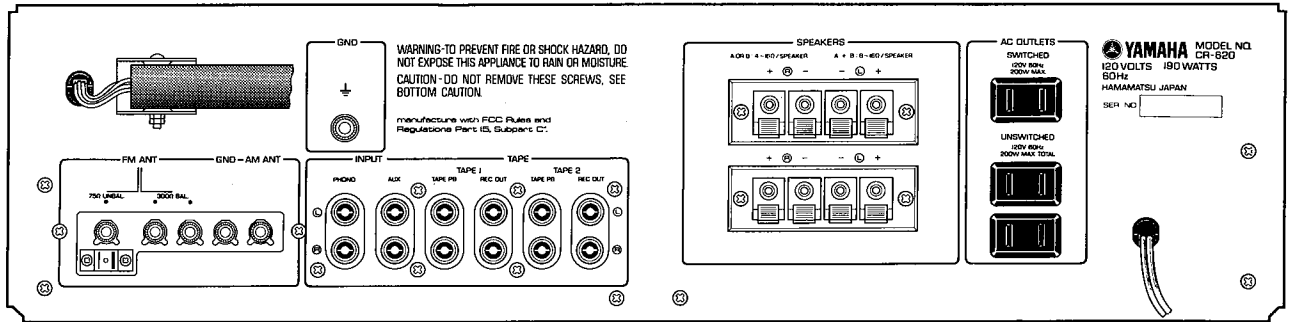

## UK & AUSTRALIAN MODEL

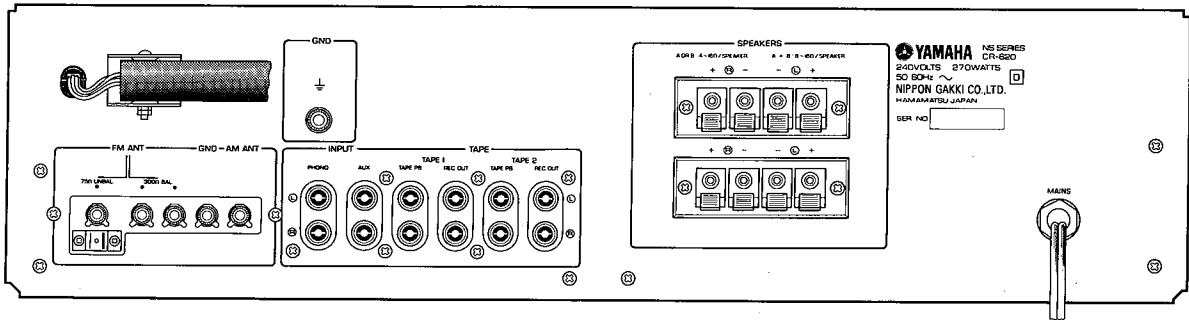

## EUROPEAN MODEL

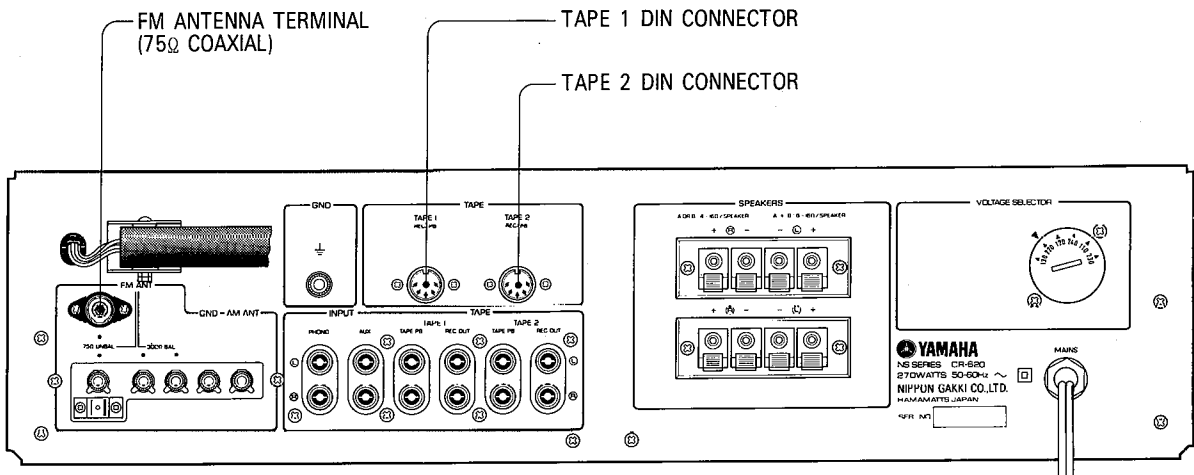

# SPECIFICATION

## AMPLIFIER SECTION

### Input Sensitivity/Impedance

Phono 1 (MM) 2mV-1kHz/50k $\Omega$ , max. 150mV  
AUX, Tape 1, 2 120mV/45k $\Omega$   
DIN 1, 2 (European model only) 120mV/37k $\Omega$

### Output Level/Impedance

REC. OUT 1, 2 120mV/220 $\Omega$ (Phono)/6k $\Omega$ (Tuner)  
max. 9V/1kHz  
DIN OUT 1,2(European model only) 30mV/52K $\Omega$   
max. 1V/1kHz 50k $\Omega$  loaded

### Frequency Response

Phono 1, 2 RIAA Deviation:  $\pm 0.5$ dB  
AUX, Tape 1, 2 to SP out:  $\pm 0.5$ dB (20Hz to 20kHz)

### Tone Controls Characteristics

BASS: Turnover 350Hz, Variable Range  $\pm 13$ dB/  
50Hz  
TREBLE: Turnover 3.5kHz, Variable Range  
 $\pm 10$ dB/20kHz

### Filter Characteristics

Low Filter:  $f_c = 25$ Hz, 12dB/oct  
High Filter:  $f_c = 10$ kHz, 12dB/oct

### Loudness Characteristics

According to the Fletcher and Munson curve

### S/N Ratio and Noise Level

Phono: 2mV 78dB (IHF A Network)  
10mV 92dB (IHF A Network)  
AUX, Tape: 97dB (IHF A Network)  
Residual Noise: 0.11mV (IHF A Network)

### Total Harmonics Distortion

Phono: 0.012% (20 to 20kHz), REC OUT 2V  
AUX, Tape: 0.02% (20 to 20kHz), SP. OUT 20W/8 $\Omega$   
Phono: 0.05%/1kHz (0.25W to 35W/8 $\Omega$ ), Vol. -20dB  
IMDist AVX 0,02% 20W/8 $\Omega$

### Rating Output and etc.

8 $\Omega$  Both ch. driven: 35W (20 to 20kHz),  
0.05% THD 40W/1kHz  
4 $\Omega$  Both ch. driven: 40W (20 to 20kHz),  
0.05% THD 50W/1kHz  
Power Band Width: 10 to 50kHz  
Dumping Factor: 40, 1kHz/8 $\Omega$

## TUNER SECTION

### FM Section Tuning Range

87.6 to 108MHz

### Usable Sensitivity

IHF mono.: 1.8 $\mu$ V (300 $\Omega$ ) 10.3dBf  
0.9 $\mu$ V (75 $\Omega$ ) 10.3dBf  
DIN mono.: 1.5 $\mu$ V (Dev: 40kHz, S/N: 26dB)  
stereo: 50 $\mu$ V (Dev: 40kHz, S/N: 46dB)

### Sensitivity When S/N 50dB

mono.: 3.2 $\mu$ V, 15.3dBf  
stereo: 43.5 $\mu$ V, 38.0dBf

### S/N Ratio

mono.: 77dB, DIN (Dev: 40kHz): 71dB  
stereo: 73dB, DIN (Dev: 40kHz): 67dB

### Image Interference Ratio (98MHz)

50dB

### IF Interference Ratio (98MHz)

75dB

### Spurious Interference Ratio (98MHz)

75dB

### Amplitude Suppression Ratio

IHF: 56dB

### Capture Ratio

1dB

### Effective Selectivity

70dB, DIN ( $\pm 300$ kHz, Dev: 40kHz): 50dB

### Total Harmonics Distortion

mono. 100Hz: 0.15%  
1kHz: 0.15%  
6kHz: 0.3%  
stereo 100Hz: 0.25%  
1kHz: 0.25%  
6kHz: 0.4%

### Cross Modulation Distortion

IHF mono.: 0.1%  
stereo: 0.2%

### Stereo Separation

50Hz: 30dB  
1kHz: 40dB  
10kHz: 30dB

### Frequency Response

50 to 10kHz:  $\pm 0.5$ dB  
30 to 15kHz:  $\pm \frac{1}{3}$  dB

### Sub Carrier Suppression

50dB

### Muting Signal Level

5 $\mu$ V (19.2dBf)

### AM Section Tuning Range

525 to 1605kHz

### Usable Sensitivity (Used Bar Antenna)

IHF: 316 $\mu$ V/m (50dB/m)

### Selectivity

1000kHz: 25dB

### S/N Ratio

80dB/m: 50dB

### Image Interference Ratio

1000kHz: 50dB

### IF Interference Ratio

1000kHz: 40dB

### Spurious Interference Ratio

1000kHz: 55dB

### Total Harmonics Distortion

80dB/m: 0.6%

### Output Level/Impedance

FM(Mod. 100%): 450mV/6.5k $\Omega$ (REC OUT)  
AM(Mod. 30%): 120mV/6.5k $\Omega$ (REC OUT)

## GENERAL

### Used Semi Conductors

68 Transistors	29 Diodes
3 ICs	5 Zenner Diodes
1 FET	4 LEDs

### Used Ceramic Filters

4 Filters

### Rated Voltage

120V/60Hz(US. and CANADA),  
240V/50, 60Hz(UK. and AUSTRALIA)  
110, 120, 130, 220, 230 and 240V/50, 60Hz  
(EUROPE and General export models)

### Rated Power Consumption

190W(US., CANADA and General export models)  
270W(UK., EUROPE and AUSTRALIA)

### Dimensions

508(W) x 167(H) x 395(D)mm  
20(W) x 6-9/16(H) x 15-9/16(D)in (US., CANADA,  
and General export models)  
488(W) x 146(H) x 395(D)mm  
19-3/16(W) x 5-3/4(H) x 15-9/16(D)in (UK. and  
EUROPE)

### Weight

12.5kg 27.5 lbs (US., CANADA, AUSTRALIA and  
General export models)  
11.5kg 25.3 lbs (UK. and EUROPE)

# CHARACTERISTICS CHARTS

## TUNER SECTION

### FM 2 SIGNALS EFFECTIVE SELECTIVITY

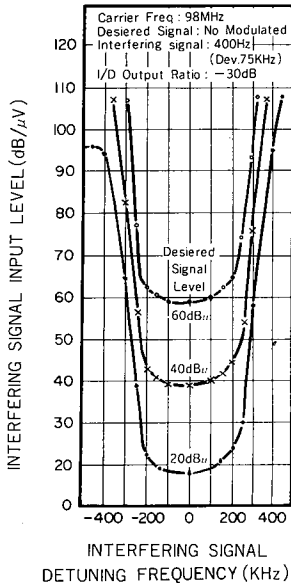

## AMPLIFIER SECTION

### FREQUENCY RESPONSE

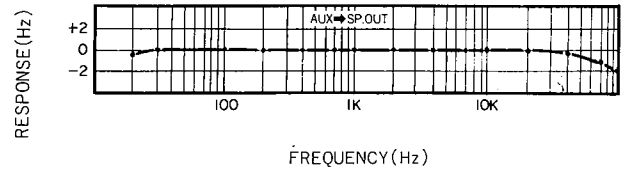

### T.H.D. V. OUT PUT

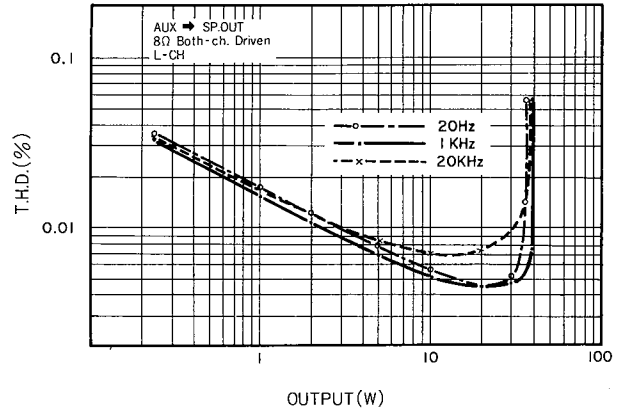

### T.H.D. V. INPUT LEVEL

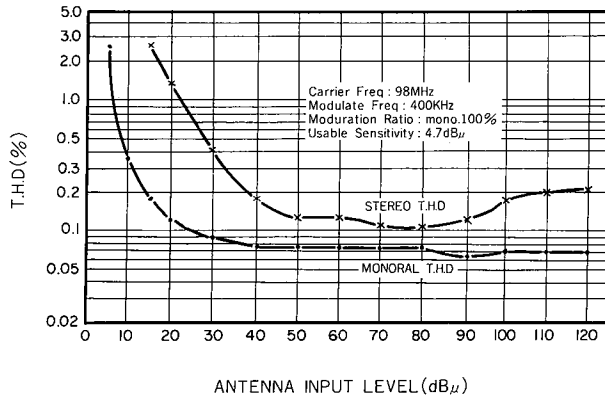

### RIAA DEVIATION

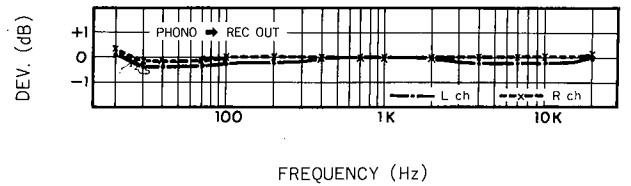

### DISTORTION V. MODULATING FREQUENCY

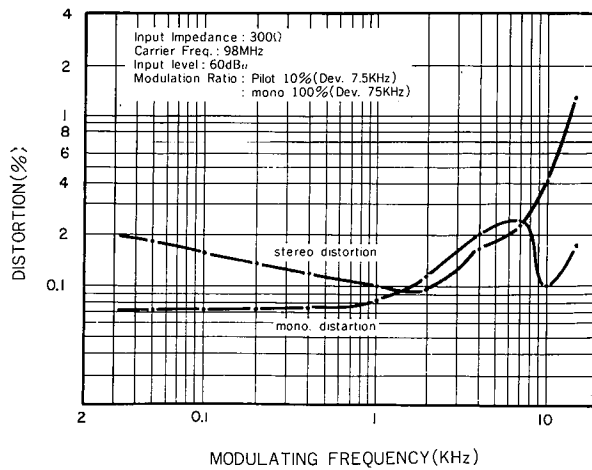

### T.H.D. V. PHONO INPUT

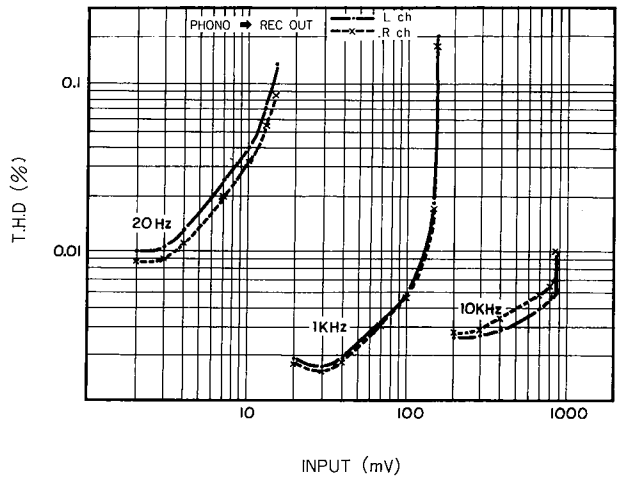



# BLOCK DIAGRAM

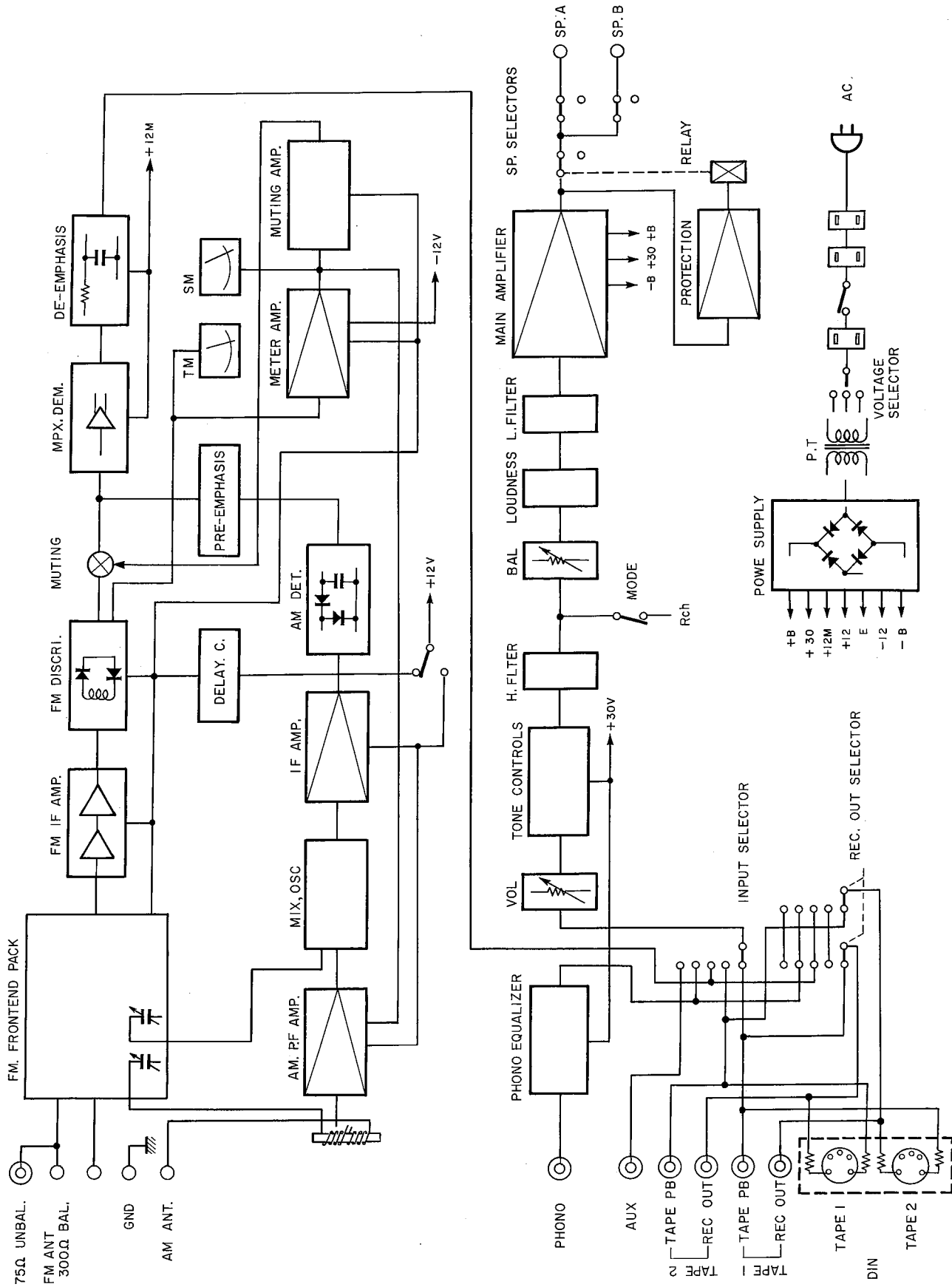

# DISASSEMBLY PROCEDURES

## FLOW CHART

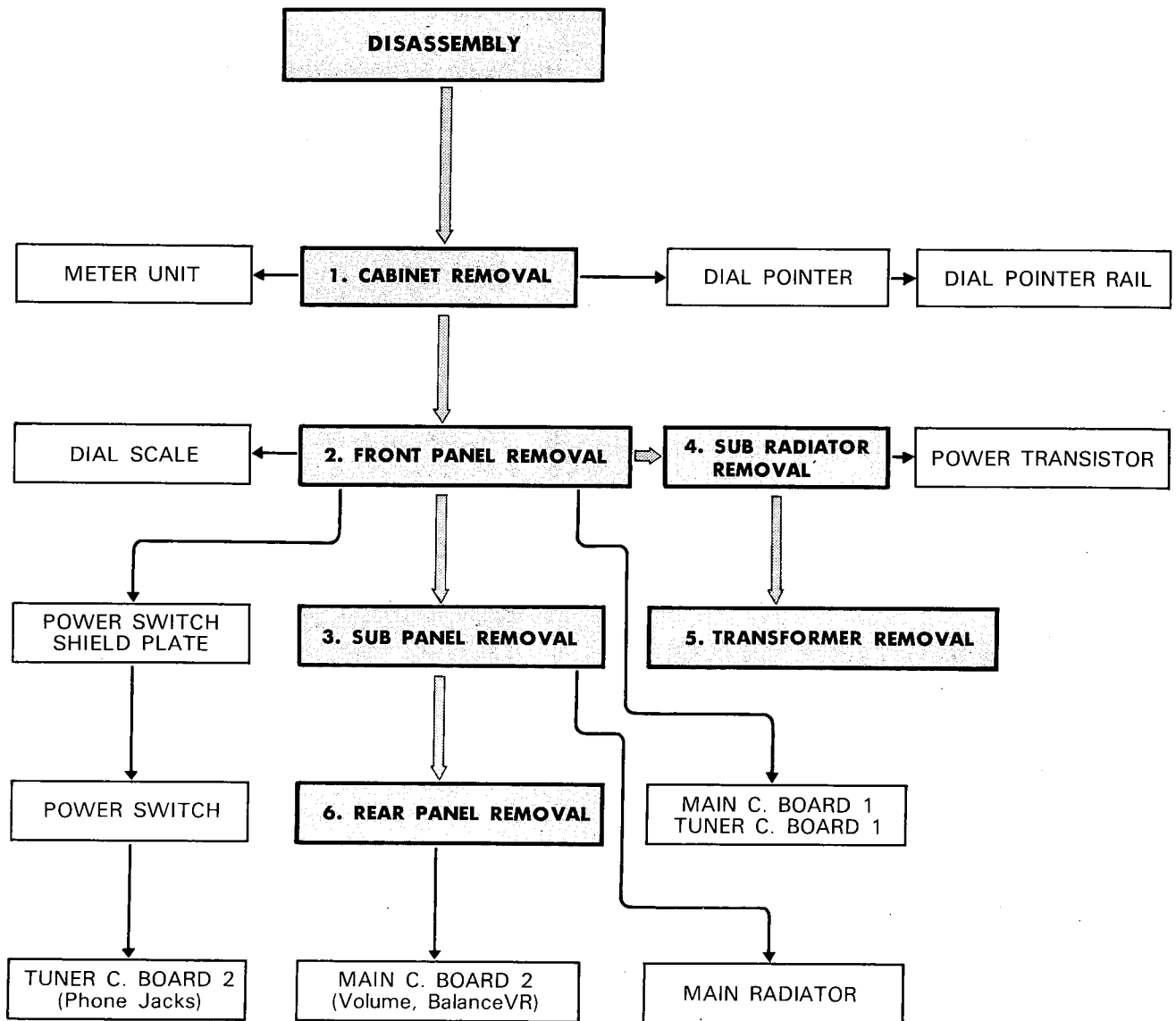

### 1. CABINET REMOVAL

Remove five screws then pull out the chassis in arrow direction.

Since the cabinet used for UK and EUROPEAN models are different from the photo shown in right hand side, refer to "EXPLODED VIEW" as shown in page 1 of the PARTS LIST.

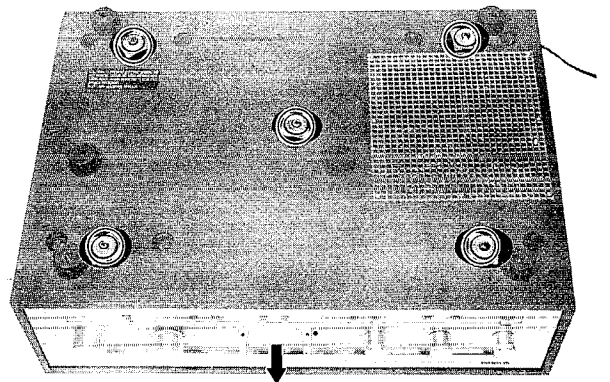

## DISASSEMBLY PROCEDURES

### 2. FRONT PANEL REMOVAL

#### Step 1. Top side

- 1) Remove four screws shown in 1 to 4.

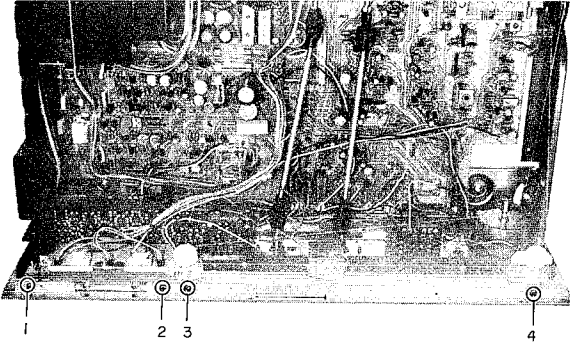

#### Step 2. Bottom side

- 1) Pull out four knobs shown in b, e, f and g.
- 2) Loosen two set screws fixing knobs shown in c and d, and pull out them.
- 3) Tuning knob removal: Insert hexagonal wrench from arrow direction and loosen two set screws, and pull out.
- 4) Remove four screws shown in 5 to 8.

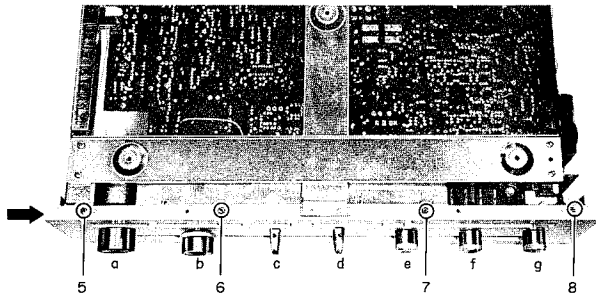

### 3. SUB PANEL REMOVAL

- 1) Remove 14 screws shown in a, b, c and d.
- 2) Remove 7 hexagonal nuts shown in e, f and g.

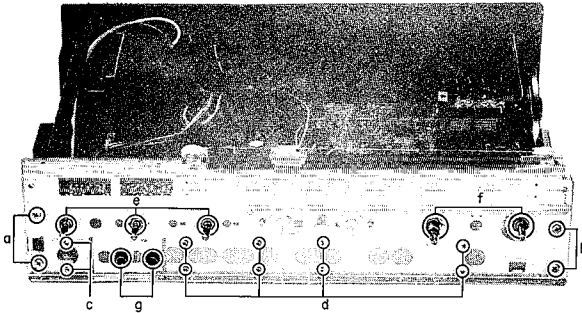

### 4. SUB RADIATOR REMOVAL

Loosen 8 (4 x 2) screws then slide radiators up and remove them.

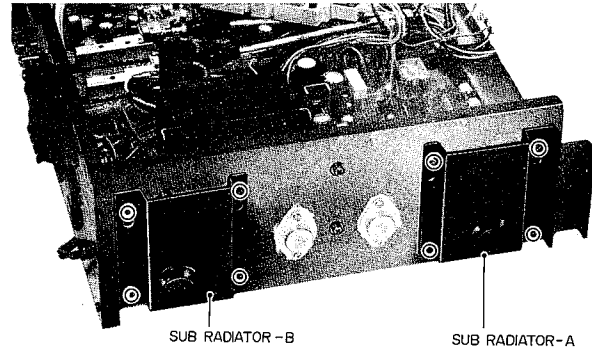

### 5. TRANSFORMER REMOVAL

a: Four screws for transformer.

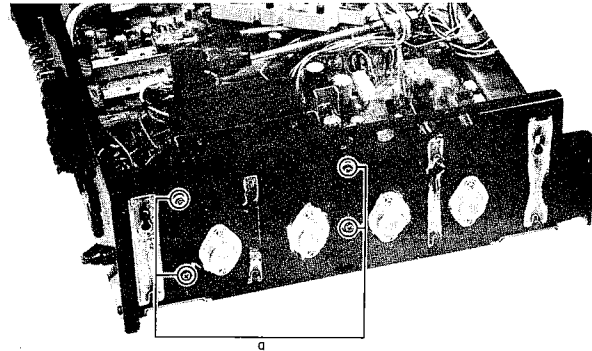

### 6. REAR PANEL REMOVAL

Remove 14 screws shown in a, b, c and d.

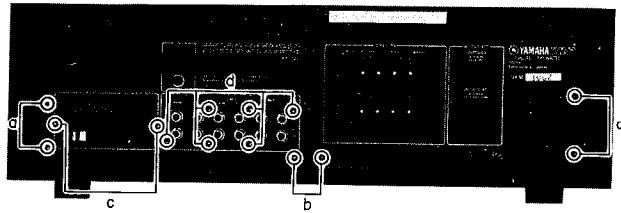

# DIAL CORD STRINGING

## DIAL CORD STRINGING

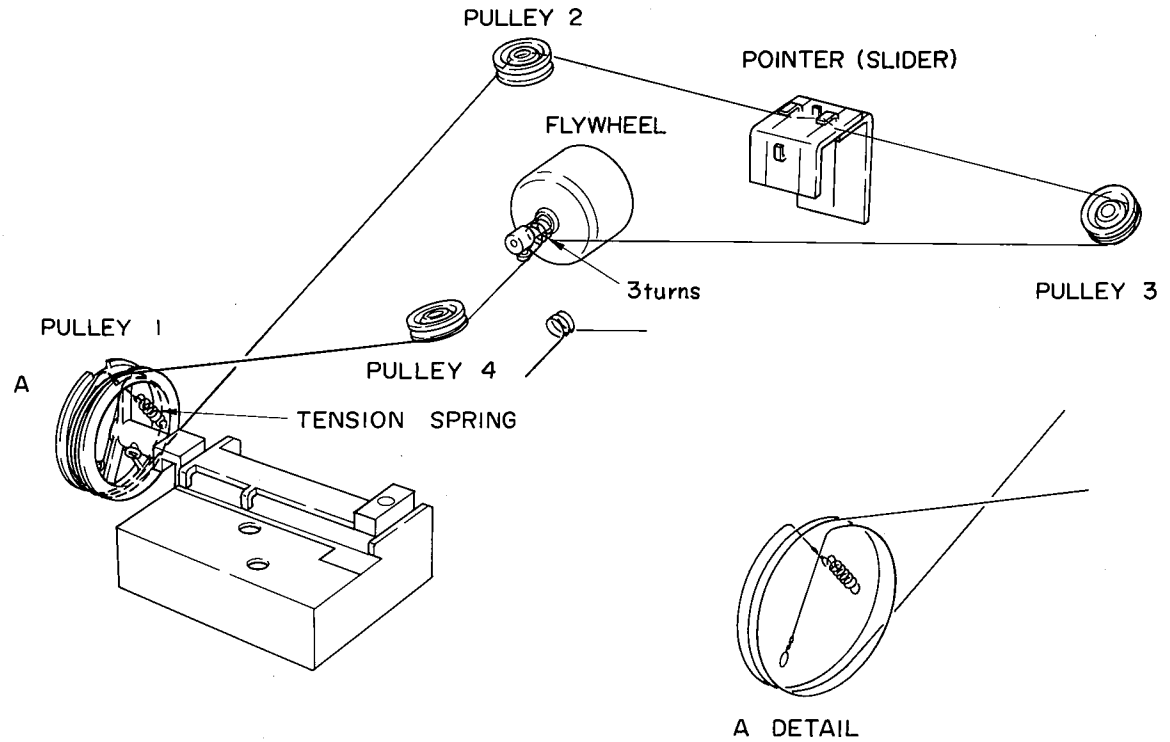

DIAL CORD LENGTH

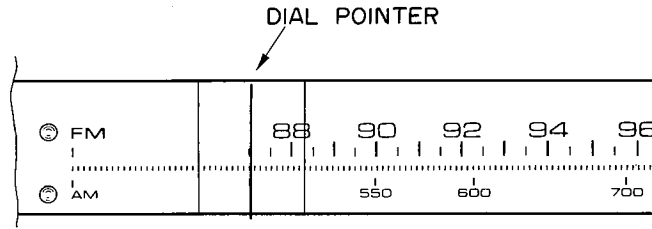
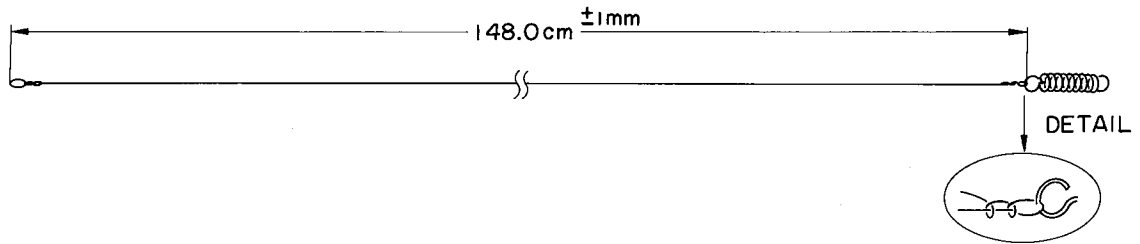

LOW END

After dial cord stringing, turn the tuning knob fully counterclockwise and set the pointer to lower end indication of the scale as illustrated above. Then hook the string to the pointer assembly and lock by painting.

## ADJUSTMENT

### ADJUSTING AMPLIFIER CIRCUIT BOARD ADJUSTING POINTS

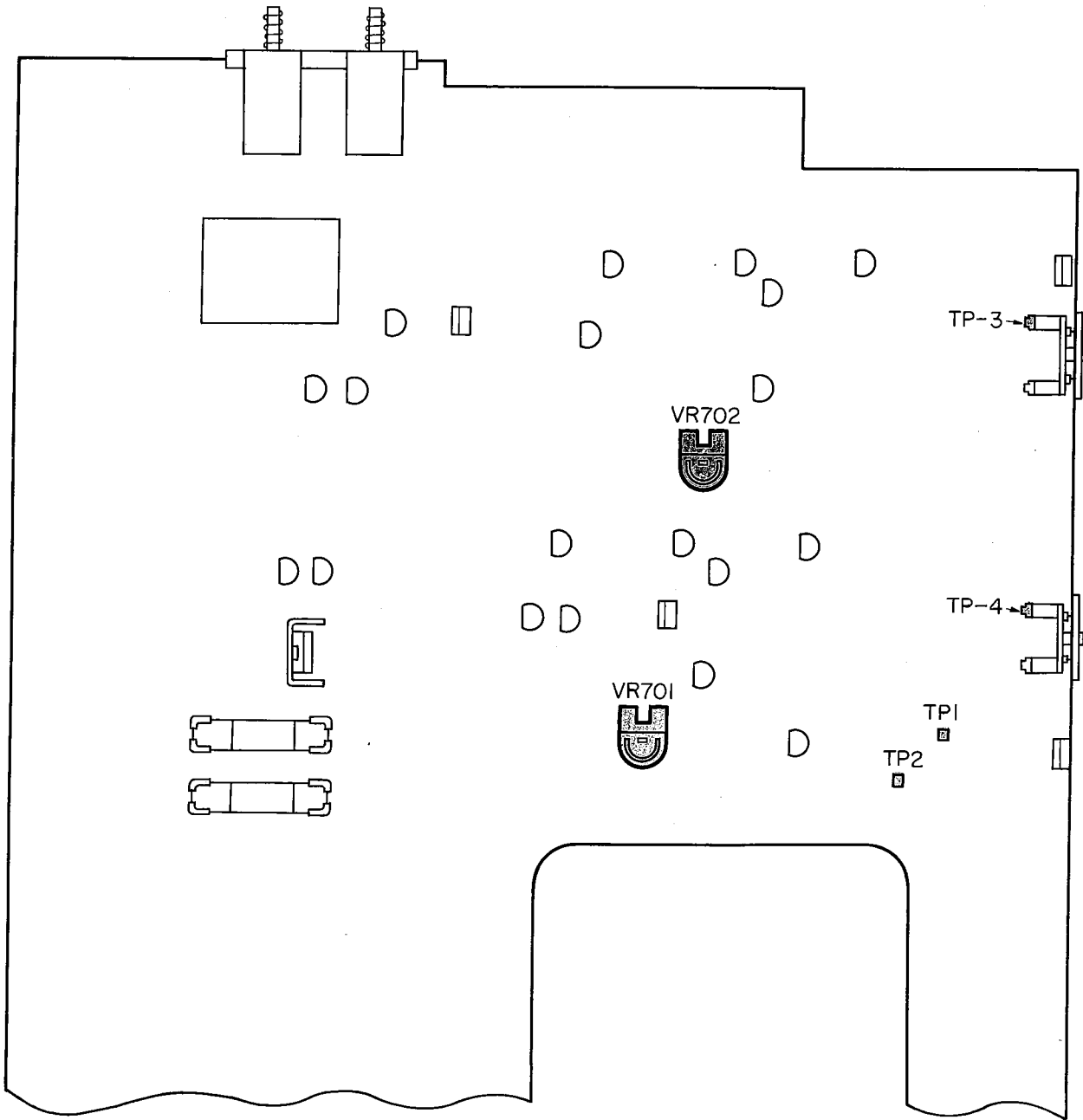

### ADJUSTMENT

ITEM	AD- JUSTING POINTS	CON- NECTING POINTS	EQUIPMENT	METHOD	INDI- CATION
IDLING CURRENT	VR701(L) VR702(R)	TP1-2 TP3-4	VTVM or Desital Volt Meter	Turn VR701 and VR702, so that the voltages between TP1 and TP2, TP3 and TP4 become rated value as shown in right hand side.	$8 \pm 2\text{mV}$

# ADJUSTMENT

## ADJUSTING TUNER CIRCUIT BOARD ADJUSTING POINTS

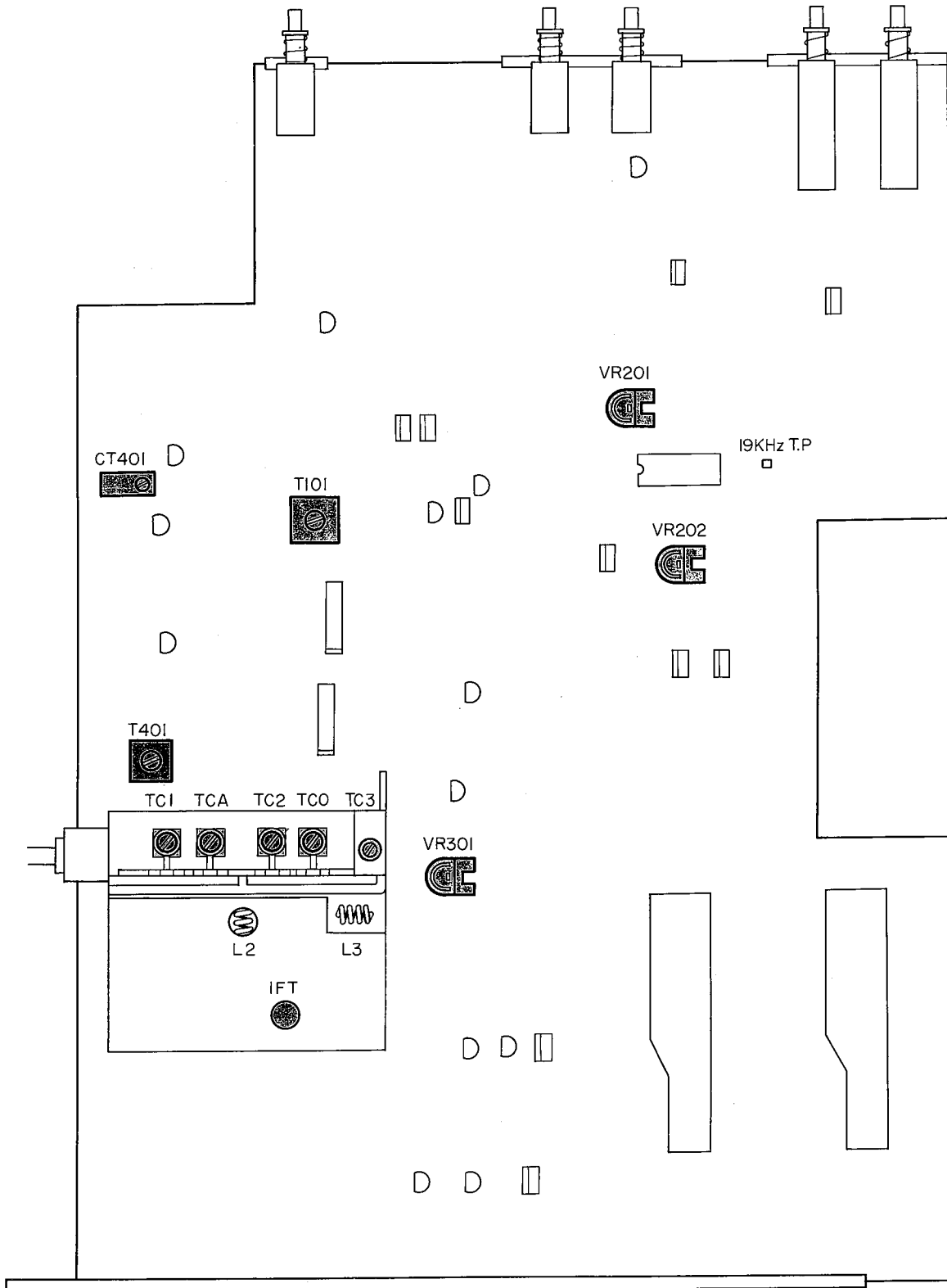

## ADJUSTMENT

### ADJUSTING TRACKING ERROR OF FM SECTION

Step	ITEMS	ADJUSTING POINTS	CONNECTING INPUT	EQUIPMENTS	METHOD	RE-MARKS
1	POINTER OF THE DIAL	Pointer	FM Ant.	FM SG 98MHz 60dB $\mu$	Tune the receiver to SG, then loosen the pointer from the dial string and set the pointer to 98MHz of the scale.	$\pm 1$ mm or less
2	HIGH END TRACKING ERROR CONFIRMATION		FM Ant.	FM SG 108MHz 60dB $\mu$	Tune the receiver to SG, then confirm that the pointer is on 108MHz of the scale.	$\pm 2$ mm or less
3	TRACKING ERROR TRIMMING (When proper confirmation cannot be made by step 2, proceed step 3.)	Pointer	FM Ant.	FM SG 88MHz to 108MHz 60dB $\mu$	Reset the pointer, so that the pointer is on within allowance in all range as shown in right hand side.	$\pm 2$ mm or less
4	TRACKING ERROR ADJUSTING (When proper adjustment cannot be made by step 3, proceed step 4.)	TC3 Pointer	FM Ant.	FM SG 98MHz 108MHz 60dB $\mu$	Adjust error by the pointer and TC3 alternately. 98MHz – pointer 108MHz – TC3	

### ADJUSTING TRACKING ERROR OF AM SECTION

ADJUST AM SECTION AFTER ADJUSTMENT OF FM SECTION MADE CORRECTLY.

Step	ITEMS	ADJUSTING POINTS	CONNECTING POINTS	EQUIPMENTS	METHOD	RE-MARKS
1	LOCAL OSCILLATING COIL ADJUSTING	T401	Bar Ant.	AM SG 600kHz 80dB/m to 100dB/m	Set the pointer to 600kHz of the scale, then turn the core of T401 slowly, so that the signal meter swings maximum.	
2	LOW END SENSITIVITY	Core of bar ant.	Bar Ant.	AM SG 600kHz 60dB/m	Turn the cord of the bar antenna coil, so that the signal meter swings maximum.	
3	LOCAL OSCILLATING CAPACITOR ADJUSTING	CT0	Bar Ant.	AM SG 1350kHz 80dB/m to 100dB/m	Set the pointer to 1350kHz of the scale, then turn the trimmer capacitor CT0, so that the signal meter swings maximum.	
4	HIGH END SENSITIVITY	CTA	Bar Ant.	AM SG 1350kHz 60dB/m	Turn the trimmer capacitor CTA, so that the signal meter swings maximum.	
5	REPEAT ADJUSTING			AM SG 600kHz 1350kHz 60dB/m	The above adjustment are necessary to repeat 2 to 3 times until minimize tracking error and differential of sensitivity between 600kHz and 1350kHz.	Tracking error: $\pm 1.5$ mm or less
6	MID RANGE CONFIRMATION		Bar Ant.	AM SG 950kHz	Tune the receiver to SG, so that the signal meter swings maximum, then confirm that the pointer is on 950kHz of the scale.	$\pm 2$ mm or less

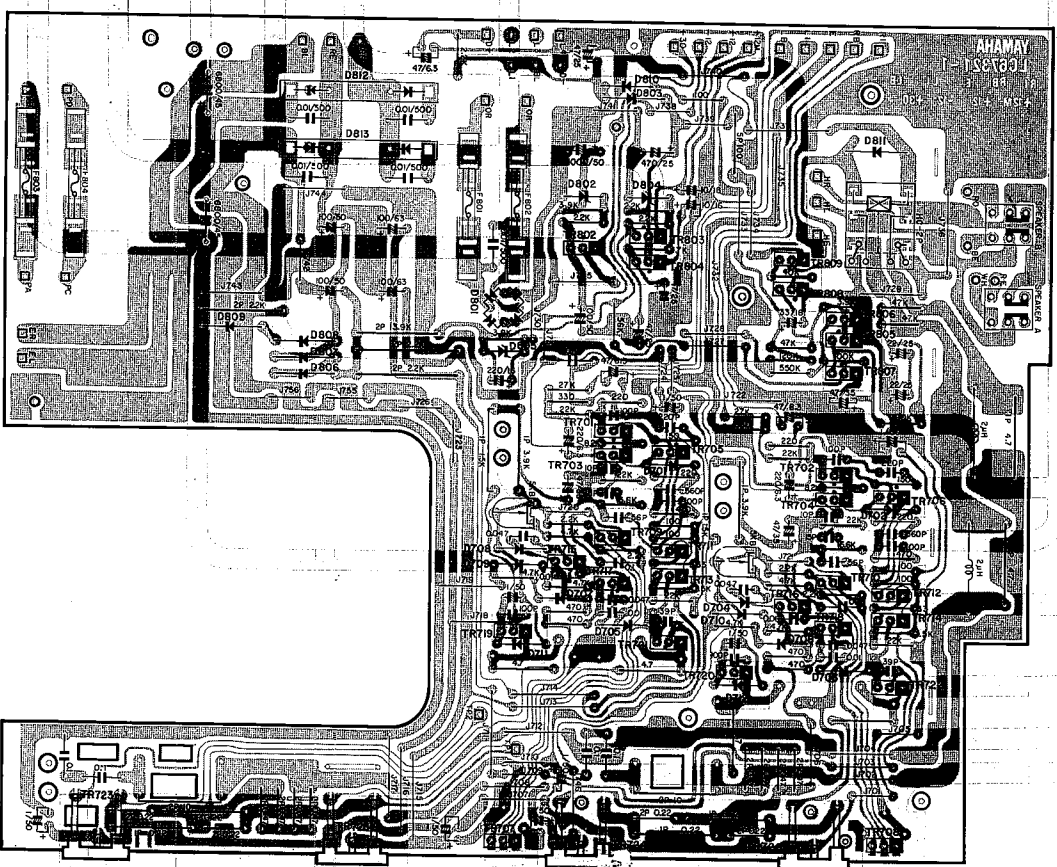
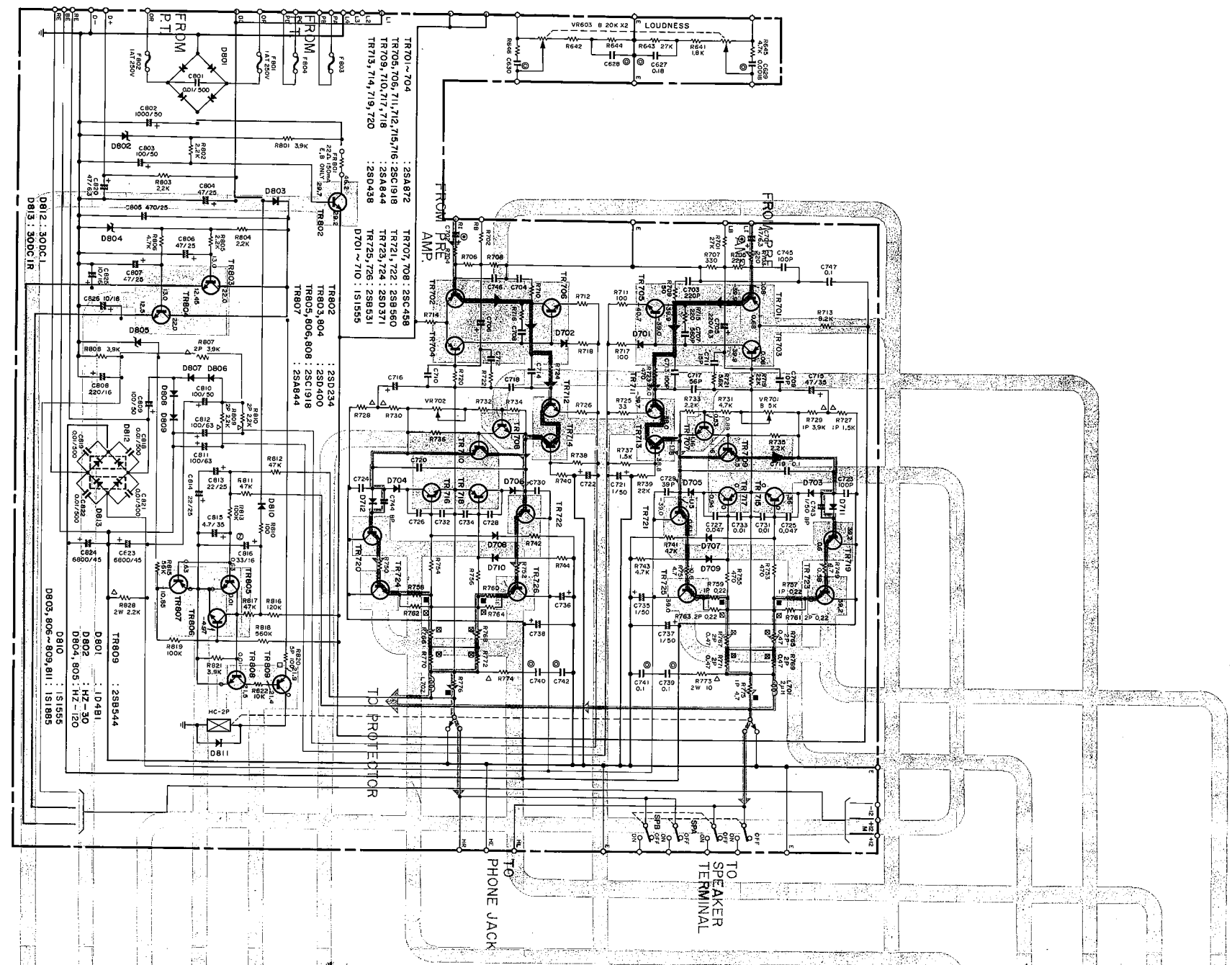



CIRCUIT BOARDS

TUNER C. BOARD 1 (Tuner)

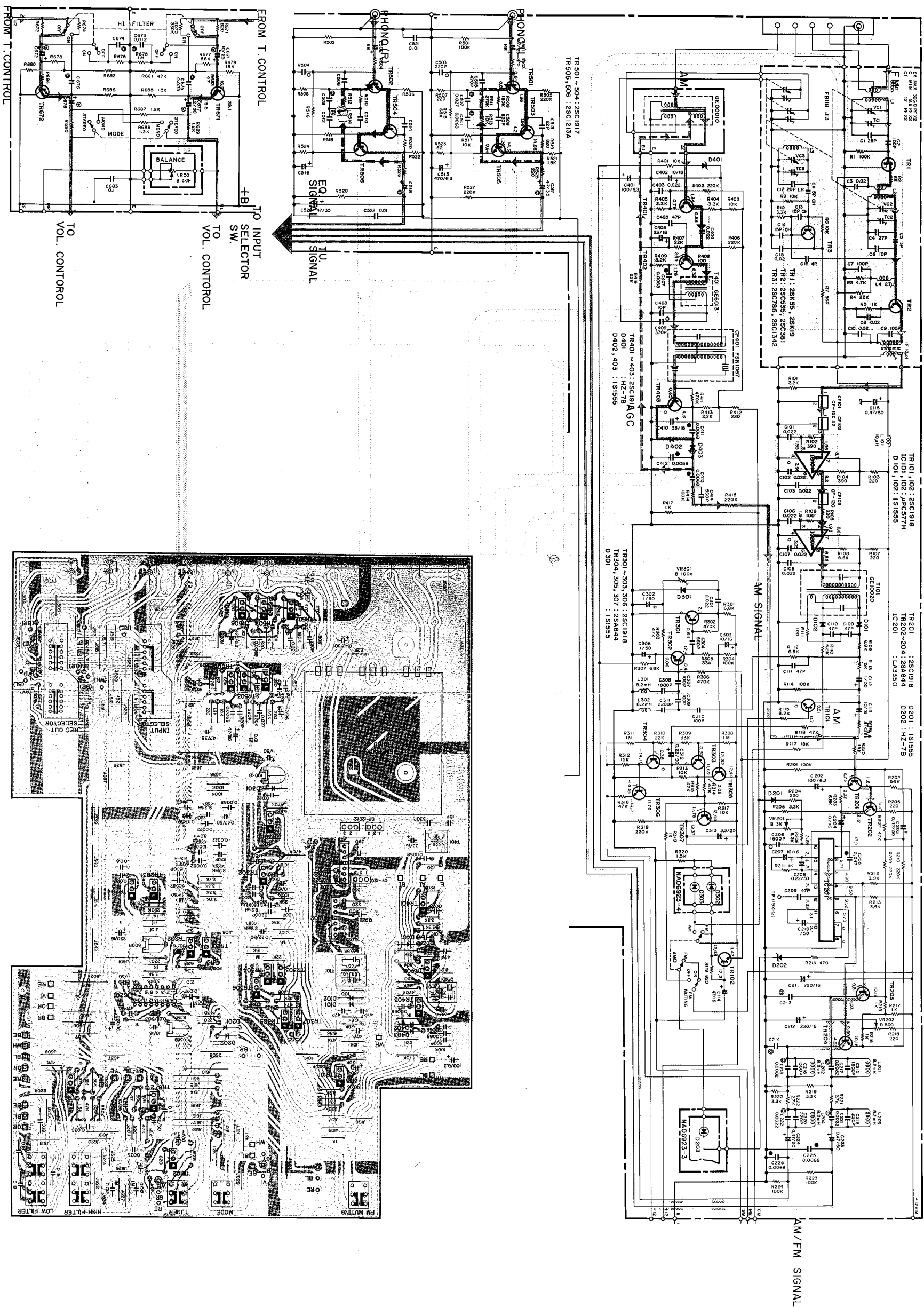



# WIRING

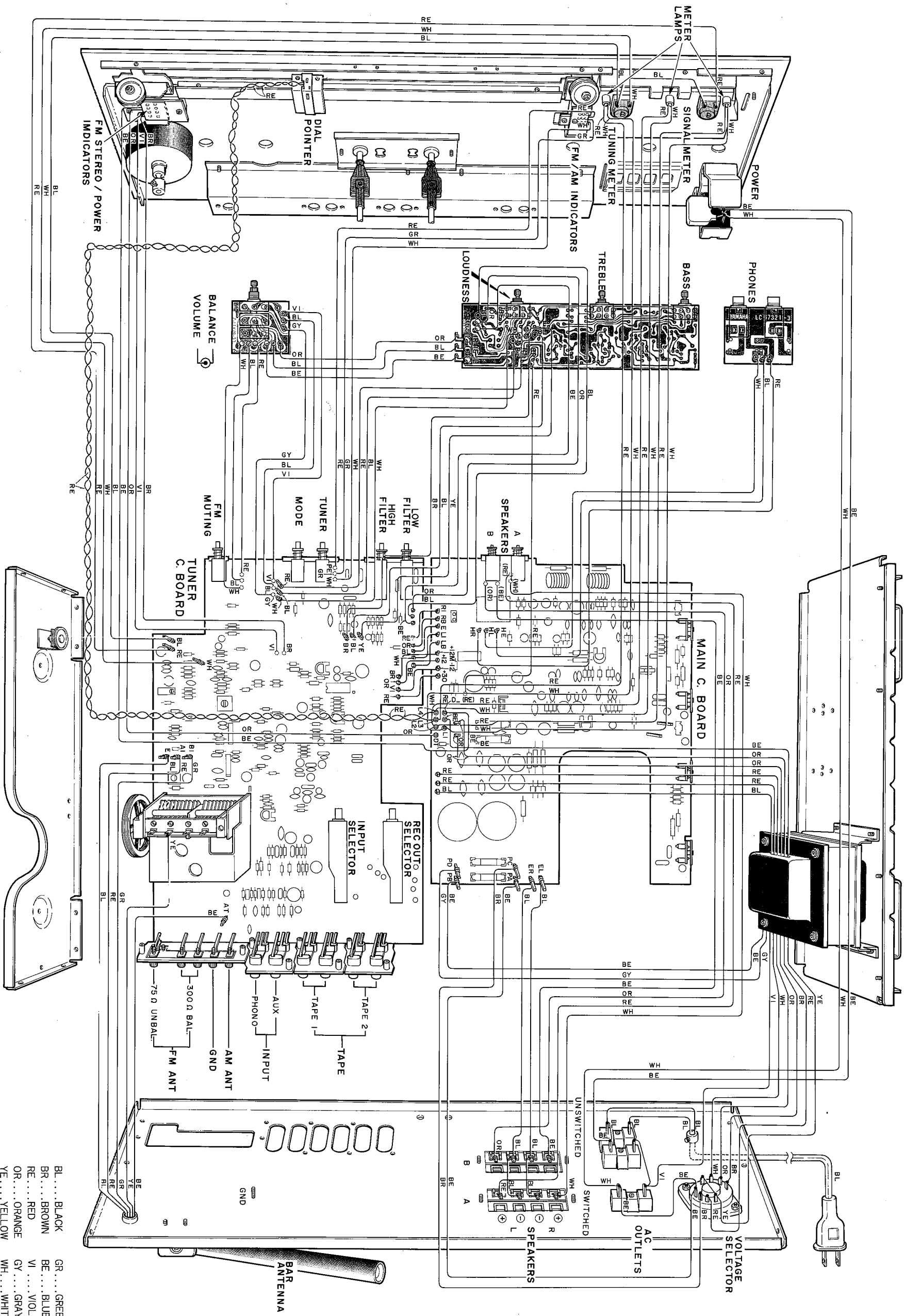

GENERAL EXPORT, U.S., AUSTRALIAN  
8 CANADIAN MODELS

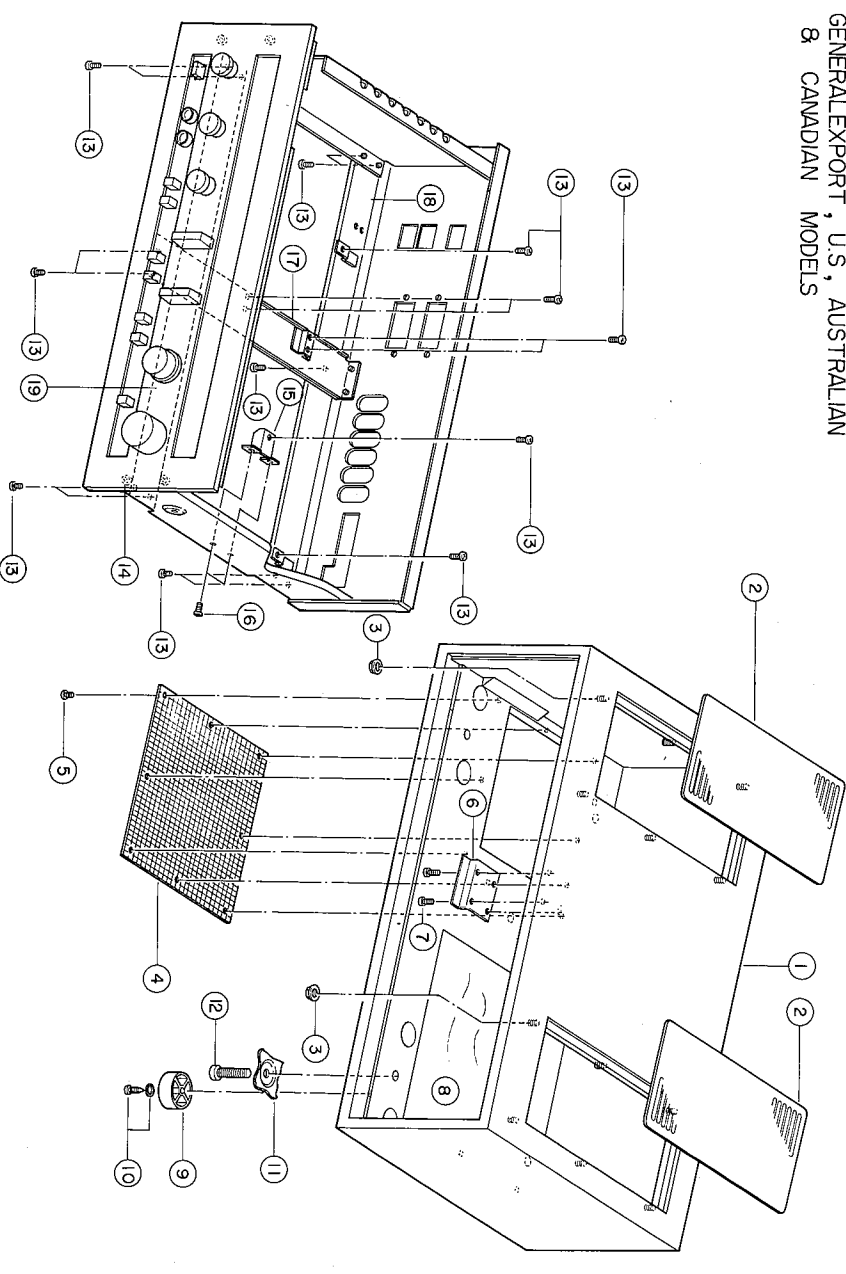

BRITISH & EUROPEAN MODELS

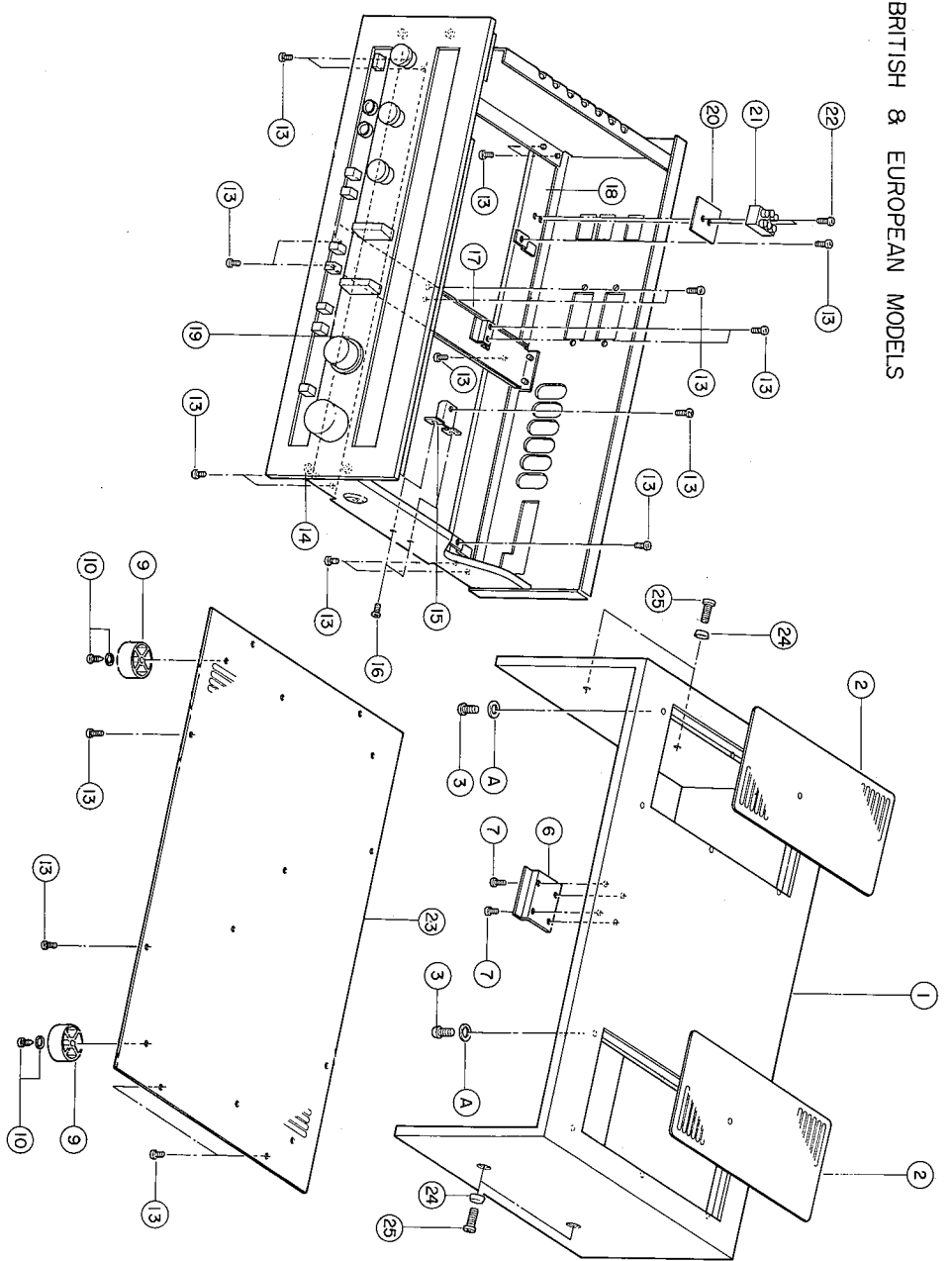

Ref. No.	Part No.	Description	Remarks	Common Models
1	3 2 0 0 1 1 9 0 6 1 5 3 1 0	Cabinet	外表組上り	CR-820
	3 2 0 0 1 1 9 0 6 1 5 4 1 0	-do-	//	-do-
2	3 2 0 0 0 0 A A 0 8 5 3 6 0	Radiator Grille	放射グリル	-do-
	3 2 0 0 0 0 C B 0 7 9 4 1 0	-do-	//	-do-
3	4 2 0 0 0 0 E V 9 0 0 0 3 0	Hexagonal Nut With Washer M3 ZMC2-Y	座付ナット	RU.A.C
	4 2 0 0 0 0 E I 0 3 0 0 8 0	Binding Tapping Screw 3X8 ZMC2-Y	パイロッドネジ	E.B
A	3 2 0 0 0 0 A A 0 7 7 2 1 0	Plain Washer 2t	平座金	E.B
4	3 2 0 0 0 0 A A 0 8 5 3 8 0	Punching Metal	パンチングメタル	RU.A.C
5	4 2 0 0 0 0 E Z 0 3 1 1 0 0	Wooden Curns Crew 3.1X10 ZMC2-Y	鉄丸座付ネジ	RU.A.C
6	3 2 0 0 0 0 A A 0 8 5 3 7 0	Metal Warp Prevention	反り止め金具	RU.A.C
	3 2 0 0 0 0 A A 0 8 5 3 5 0	-do-	//	-do-
7	4 2 0 0 0 0 E Q 7 3 1 1 0 0	Wooden Screw 3.1X10 ZMC2-Y	鉄丸ネジ	E.B
8	4 2 0 0 0 0 C A 0 6 5 7 0 0	Shield Paper	バリヤ紙	RU.A.C
9	4 2 0 0 0 0 C B 0 7 9 4 9 0	Leg	脚	RU.A.C
A	4 2 0 0 0 0 E J 0 4 0 1 4 0	Pan Head Tapping Screw 4X14 ZMC2-Y	パンヘッドネジ	E.B
10	4 2 0 0 0 0 E Q 7 4 1 1 0 0	Wooden Screw 4.1X10 ZMC2-Y	鉄丸ネジ	RU.A.C
11	3 2 0 0 0 0 A A 0 7 4 6 3 0	Amp. Setting Washer	アンプ調整ワッシャー	RU.A.C
12	4 2 0 0 0 0 E A 0 5 0 2 5 0	Pan Head Screw 5X25 ZMC2-Y	パンヘッドネジ	RU.A.C
13	4 2 0 0 0 0 E I 0 3 0 0 8 0	Binding Tapping Screw 3X8 ZMC2-Y	パイロッドネジ	
14	4 2 0 0 0 0 E I 0 4 0 0 8 0	-do- 4X8 ZMC2-Y	//	
15	3 2 0 0 0 0 A A 0 8 5 1 8 0	Holder, Tuner C.Board	ホルダー	CR-820
16	4 2 0 0 0 0 E D 0 3 0 0 6 0	Binding Head Screw 3X6 ZMC2-Y	パイロッドネジ	
17	3 2 0 0 0 0 A A 0 8 5 0 4 0	Center Frame	センターフレーム	CR-820
18	3 2 0 0 0 0 A A 0 8 5 0 6 0	R-Bridge	Rブリッジ	-do-
A	4 2 0 0 0 0 L A 0 0 2 8 0	Lug Terminal 3mm	テースラグ	A
B	4 2 0 0 0 0 E I 0 3 0 0 6 0	Binding Tapping Screw 3X6 ZMC2-Y	パイロッドネジ	A
19	3 2 0 0 0 0 A A 0 8 5 0 5 0	F-Bridge	Fブリッジ	-do-
20	3 2 0 0 0 0 C B 0 7 4 9 7 0	Isolation Plate # 7497	絶縁板	A.E.B
21	4 2 0 0 0 0 L A 0 0 1 0 4 0	Board, Terminal 3P	3P中継端子台	A.E.B
22	4 2 0 0 0 0 E D 0 3 0 1 6 0	Binding Head Screw 3X16 ZMC2-Y	パイロッドネジ	A.E.B
23	3 2 0 0 0 0 A A 0 8 5 0 2 0	Bottom Cover	ボトムカバー	E.B
24	3 2 0 0 0 0 C B 0 7 9 5 2 0	Hole-Cap	ホールキャップ	E.B
25	4 2 0 0 0 0 E D 4 5 0 1 4 0	Binding Head Screw 5X14 FCM3-BI	パイロッドネジ	E.B

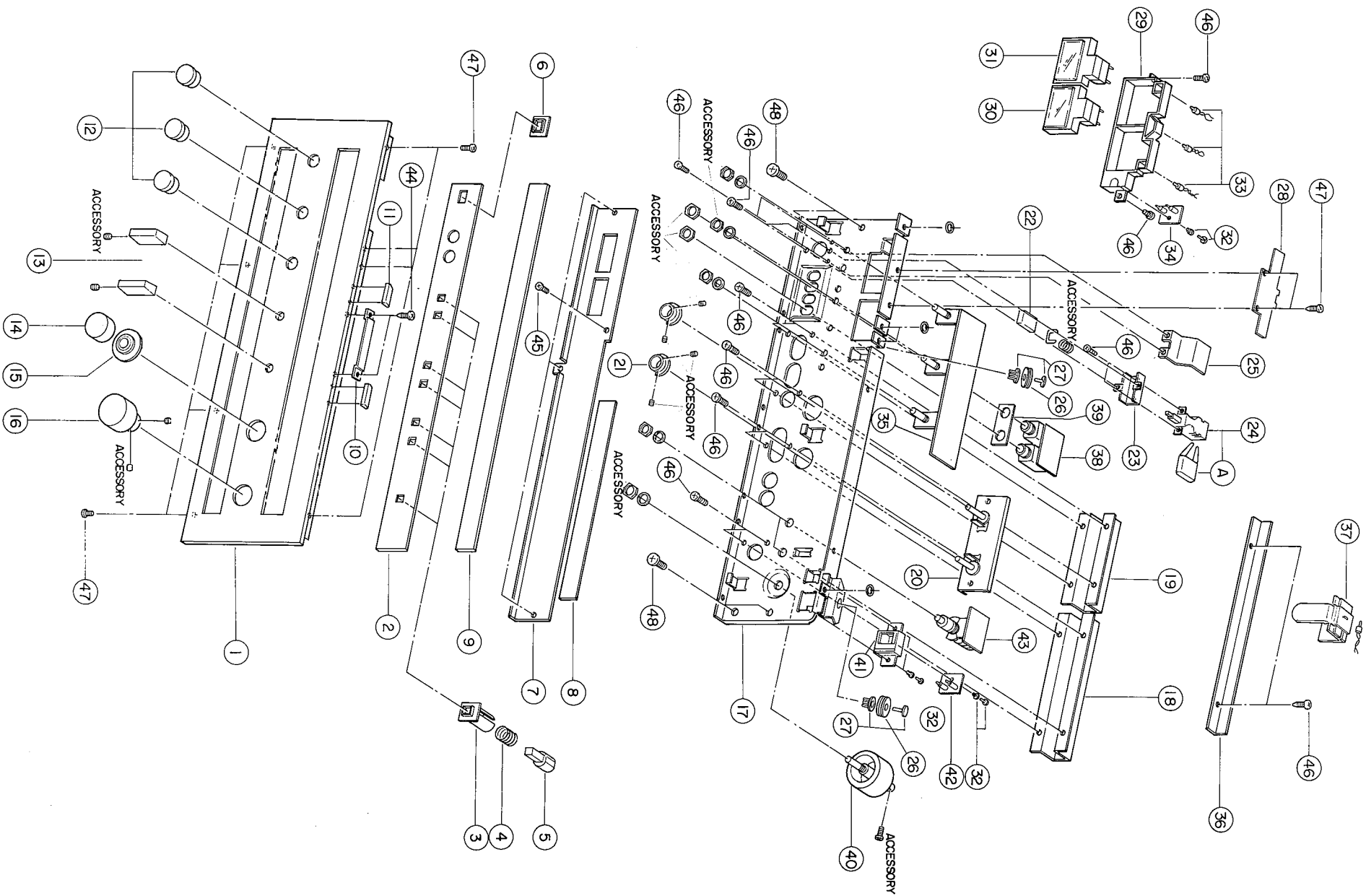

Ref. No.	Part No.	Description	Remarks	Common Models
1	3 2 0 0 0 0 BA 0 6 9 8 8 0	Panel	パネル	
2	3 2 0 0 0 0 BA 0 6 9 8 9 0	Sub Panel	サブパネル	
3	3 2 0 0 0 0 CB 0 7 9 2 5 0	Frame, Push SW. Button	フレームボタン枠	CR-820 10Z020Z0
4	3 2 0 0 0 0 AA 0 8 4 5 9 0	Spring, Push SW.	フレームボタンバネ	—do.—
5	3 2 0 0 0 0 CB 0 7 9 2 4 0	Button, Push SW.	フレームボタン	—do.—
6	3 2 0 0 0 0 CB 0 7 9 3 5 0	Frame, Power SW. Button	パワーボタン枠	CR-820
7	3 2 0 0 0 0 NB 0 7 8 3 7 0	Dial Scale Unit	目盛板ユニット	CR-400
8	4 2 0 0 0 0 CB 0 6 8 8 3 0	Double Face 30×210	ダイヤルフェイス	CR-820
9	3 2 0 0 0 0 CG 0 6 0 4 6 0	Dial Panel	ダイヤルパネル	CR-820 10Z020Z0
10	3 2 0 0 0 0 AA 0 8 4 9 4 0	Metal, Warp Prevention	反り止め金具	—do.—
11	3 2 0 0 0 0 CB 0 7 9 3 2 0	Spacer, Warp Prevention	反り止めスペーサー	—do.—
12	3 2 0 0 0 0 BA 0 6 4 4 6 0	Knob, LN	ツマミ	CA-1000
13	3 2 0 0 0 0 BA 0 6 7 7 9 0	Knob, Switch	スイッチツマミ	CA-610 CR-820
14	3 2 0 0 0 0 BA 0 6 9 8 6 0	Knob, Volume Control	ボリュームツマミ	CR-820
15	3 2 0 0 0 0 BA 0 6 9 8 7 0	Knob, Balance Control	バランスツマミ	—do.—
16	3 2 0 0 0 0 BA 0 6 9 8 5 0	Knob, Tuning	チューニングツマミ	—do.—
17	3 2 0 0 0 0 AA 0 8 5 0 1 0	Sub Chassis	サブシャーシ	—do.—
18	3 2 0 0 0 0 AA 0 8 5 2 8 0	Holder A, Push SW.	フレームA	—do.—
19	3 2 0 0 0 0 AA 0 8 5 2 9 0	Holder B, Push SW.	フレームB	—do.—
20	3 2 0 0 0 0 AA 0 8 5 2 7 0	Shaft Unit	シャフトユニット	CR-820
21	3 2 0 0 0 0 CB 0 7 9 3 9 0	SW. Limiter	スイッチリミッター	—do.—
22	3 2 0 0 0 0 CB 0 7 9 3 4 0	Button, Power SW.	パワーボタン	—do.—
23	3 2 0 0 0 0 AA 0 8 5 1 5 0	Holder, Power SW.	パワーボタンホルダー	—do.—
24	4 2 0 0 0 0 KA 8 0 0 2 4 0	Push Switch SPG TV-5	パワースイッチ	—do.—
	4 2 0 0 0 0 KA 8 0 0 1 8 0	—do— 1P-0009AF2020	—do—	—do.—
A	4 2 0 0 0 0 FZ 0 0 0 5 4 0	Spark Killer AG350V 0.033+120	スパークキラー	—do.—
	4 2 0 0 0 0 FZ 0 0 0 1 1 0	—do— AC125V 0.33+120	—do—	—do.—
	4 2 0 0 0 0 FZ 0 0 0 6 9 0	—do— DG500V AC350V 0.022μ	—do—	—do.—
	4 2 0 0 0 0 FZ 0 0 0 9 5 0	—do— 250V 2CA-120033	—do—	CR-2020
B	4 2 0 0 0 0 CB 0 7 2 1 9 0	Cover For Capacitor 820826	コンデンサカバー	CR-400 CR-820
	4 2 0 0 0 0 CB 0 7 9 8 9 0	—do— SB-0653a	—do—	CR-2020
C	3 2 0 0 0 0 NA 0 6 9 2 0 4	Main Circuit Board, 4	メインボード4	E
	3 2 0 0 0 0 NA 0 6 9 1 9 4	—do—	—do—	B
25	3 2 0 0 0 0 AA 0 8 5 2 0 0	Shield Plate, Power SW.	PSシールド板	CR-820
A	3 2 0 0 0 0 CB 0 7 9 9 3 0	Isolation Plate, Power SW.	PS絶縁板	—do.—
B	4 2 0 0 0 0 EI 0 3 0 8 8 0	Binding Tapping Screw 3×8 ZMC2-Y	バイディングタッピングネジ	B
26	3 2 0 0 0 0 CB 0 7 5 8 4 0	Wheel	滑車	CT-1010 CR-820
27	3 2 0 0 0 0 CB 0 7 7 8 9 0	Pulley-Crip	プーリークリップ	—do.—
28	3 2 0 0 0 0 AA 0 8 5 1 9 0	Holder, Meter Unit	メーター押え金具	CR-820
29	3 2 0 0 0 0 CB 0 7 9 3 3 0	Holder, Meter	メーターホルダー	—do.—
A	3 2 0 0 0 0 CB 0 7 9 3 1 0	Colour Plate	カラープレート	CR-820 10Z020Z0
30	4 2 0 0 0 0 JI 0 0 0 6 7 0	Tuning Meter	チューニングメーター	CR-820
31	4 2 0 0 0 0 JI 0 0 0 6 6 0	Signal Q Meter	シグナルQメーター	—do.—
32	4 2 0 0 0 0 CB 0 6 8 8 8 0	Plastic Rivet φ3.5	プラスチックリベット	—do.—
33	3 2 0 0 0 0 MZ 0 6 9 3 7 0	Lamp Assy	ランプアッシー	CR-820
34	3 2 0 0 0 0 NA 0 6 9 2 3 4	Tuner Circuit Board, 4	チューナーボード4	RUJC
	3 2 0 0 0 0 NA 0 6 9 2 4 4	—do—	—do—	E
	3 2 0 0 0 0 NA 0 6 9 2 5 4	—do—	—do—	—do.—
A	4 2 0 0 0 0 IF 0 0 0 6 8 0	Light Emitting Diode SLP132B	LED	AB
B	3 2 0 0 0 0 CB 0 7 9 3 0 0	Spacer For LED	LEDスペーサー	CR-820 10Z020Z0



GENERAL EXPORT MODELS

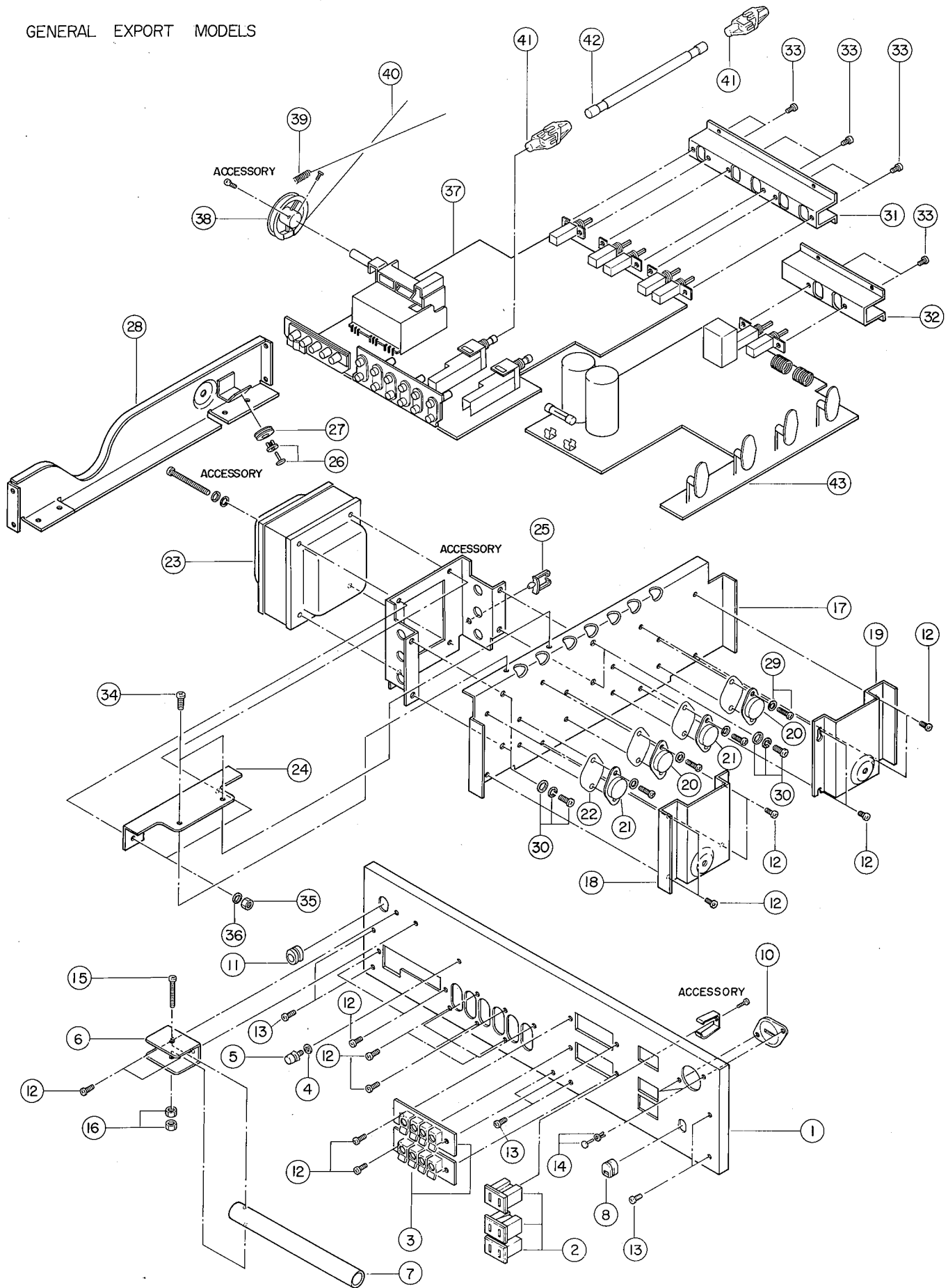

Ref. No.	Part No.		Description	Remarks	Common Models
1	3 2 0 0 0 0	A A 0 8 5 2 3 0	Rear Panel, R	リアパネル	R
2	4 2 0 0 0 0	L B 2 0 0 7 1 0	AC Socket S-1642B	ACコンセント	R,U,C CA-400
3	4 2 0 0 0 0	L A 0 0 1 9 4 0	4P Push Terminal	4Pプッシュターミナル	
4	4 2 0 0 0 0	E V 9 0 1 3 6 0	Thoothed Locked Washer φ3.6 FNM3-3g	セムス平座金	
5	4 2 0 0 0 0	L A 0 0 1 0 7 0	Earth Terminal	アース端子	CA-1000
6	3 2 0 0 0 0	A A 0 7 6 9 7 0	Antenna Holder	アンテナホルダー	CR-820, 1020,2020
7	4 2 0 0 0 0	G E 0 0 0 1 0 0	AM Bar Antenna	AMバーアンテナ	
8	4 2 0 0 0 0	C B 0 7 0 6 9 0	Cord Stopper SR-3P-4	コードストッパー	R,U,C CA-1000
9	4 2 0 0 0 0	M G 0 0 0 3 4 0	AC Cord	ACコード	R,U,C C-2
10	4 2 0 0 0 0	L B 2 0 0 2 6 0	Voltage Selector SWP033-3023	電圧切換器	R,E
11	3 2 0 0 0 0	C B 0 6 2 7 8 0	Rubber Spacer	ゴムブッシュ	R,A,E,B
12	4 2 0 0 0 0	E i 4 3 0 0 8 0	Binding Tapping Screw 3×8 FCM3-BI	バインド タッピングネジ	
A	4 2 0 0 0 0	C B 0 7 8 2 5 0	Screw Cover 3S	ビスカバー	R,E
13	4 2 0 0 0 0	E Z 4 3 0 0 8 0	Bonding Tapping Screw 3×8 FCM3-BI	ボンディング タッピングネジ	
14	4 2 0 0 0 0	C B 0 6 8 8 8 0	Plastic Rivet φ3.5	プラスチック リベット	R,E
15	4 2 0 0 0 0	E A 4 3 0 2 5 0	Pan Head Screw 3×25 FCM3-BI	ナベ小ネジ	
16	4 2 0 0 0 0	E V 1 0 0 3 0 0	Hexagonal Nut M3 FCM3-BI	六角ナット	
17	3 2 0 0 0 0	B A 0 6 9 8 0 0	Radiator	ラジエター	
18	3 2 0 0 0 0	B A 0 6 9 8 1 0	Sub-Radiator, A	サブラジエター A	
19	3 2 0 0 0 0	B A 0 6 9 8 2 0	—do.— B	サブラジエター B	
20	4 2 0 0 0 0	i D 0 3 7 1 0 0	Transistor 2SD371 R, O	トランジスター	
21	4 2 0 0 0 0	i B 0 5 3 1 0 0	—do.— 2SB531 R, O	//	
22	4 2 0 0 0 0	i 1 0 0 0 2 3 0	Isolation Base, Mica	マイカベース	
23	4 2 0 0 0 0	G A 6 1 0 5 2 0	Power Transformer	電源トランス	R,E
	4 2 0 0 0 0	G A 6 1 0 5 1 0	—do.—	//	U
	4 2 0 0 0 0	G A 6 1 0 5 4 0	—do.—	//	C
	4 2 0 0 0 0	G A 6 1 0 5 8 0	—do.—	//	A,B
A	4 2 0 0 0 0	L A 0 0 0 5 9 0	Press Terminal 2-SD	圧着端子	A
24	3 2 0 0 0 0	A A 0 8 6 6 2 0	Angle Iron For Transformer	トランスアングル	CR-820
25	3 2 0 0 0 0	C B 0 6 9 4 8 0	Wire Supporter	ワイヤークリップ	CR-200, 820
26	3 2 0 0 0 0	C B 0 7 7 8 9 0	Pulley-Crip	プーリークリップ	CT-1010
27	3 2 0 0 0 0	C B 0 7 5 8 4 0	Wheel	滑車	CT-1010
28	3 2 0 0 0 0	A A 0 8 5 0 3 0	Side Frame	サイドフレーム	
29	4 2 0 0 0 0	E Z 3 3 0 1 4 0	B.W Head Screw 3×14 FNM3-3m	B.Wヘッド小ネジ	
30	4 2 0 0 0 0	E H 0 4 0 1 0 0	Pan Head Sems Type Screw 4×10 3Pieces ZMC2-Y	セムスナベ小ネジ	
31	3 2 0 0 0 0	A A 0 8 5 2 8 0	Holder A, Push SW.	プッシュスイッチ ホルダー A	
32	3 2 0 0 0 0	A A 0 8 5 2 9 0	Holder B, Push SW.	プッシュスイッチ ホルダー B	
33	4 2 0 0 0 0	E D 0 3 0 0 6 0	Binding Head Screw 3×6 ZMC2-Y	バインド小ネジ	
34	4 2 0 0 0 0	E i 0 4 0 0 8 0	Binding Tapping Screw 4×8 ZMC2-Y	バインド タッピングネジ	
35	4 2 0 0 0 0	E V 1 0 0 0 4 0	Hexagonal Nut M4	六角ナット	
36	4 2 0 0 0 0	E V 2 0 0 0 3 0	Flat Washer 4S ZMC2-Y	平座金ミガキ丸	



Ref. No.	Part No.	Description	Remarks	Common Models
37	3 2 0 0 0 0 N A 0 6 9 2 3	Tuner C.Board 1	チューナーシート1	R,U,C
	3 2 0 0 0 0 N A 0 6 9 2 4	-do.-	//	E
	3 2 0 0 0 0 N A 0 6 9 2 5	-do.-	//	A,B
A	4 2 0 0 0 0 F S I 1 3 6 8 0	BL Ccramic Capacitor 50V0.0068 $\mu$	SBLコン	
	4 2 0 0 0 0 F S I 3 4 4 7 0	-do.- 50V0.047 $\mu$	//	
	4 2 0 0 0 0 F Z 0 0 0 5 3 0	Electrolytic Cap. MS 25V10 $\mu$	MSケミコン	
	4 2 0 0 0 0 F Z 0 0 0 9 0 0	-do.- 50V2.2 $\mu$	//	
	4 2 0 0 0 0 F Z 0 0 0 4 9 0	-do.- 35V4.7 $\mu$	//	
	4 2 0 0 0 0 F Z 0 0 0 9 9 0	-do.- RB 25V4.7 $\mu$	RBケミコン	
B	4 2 0 0 0 0 G E 3 0 0 1 3 0	RF Inductor Coil 10 $\mu$ H	RFインダクター	
	4 2 0 0 0 0 G E 3 0 0 1 5 0	-do.- 8.2mH	//	
	4 2 0 0 0 0 G E 1 0 0 2 0 0	FM Discriminater Coil	FMディスクリ コイル	
	4 2 0 0 0 0 G E 1 0 0 1 5 0	OSC. Coil, AM GE6013	OSCコイル	
C	4 2 0 0 0 0 G G 0 0 0 1 7 0	Ceramic Filter CFM-107M-12C	セラミック フィルタ	
	4 2 0 0 0 0 G G 0 0 0 0 8 0	-do.- FSN1067	//	
D	4 2 0 0 0 0 H T 1 7 0 0 4 0	Variable Resistor B500	半固定抵抗	
	4 2 0 0 0 0 H T 1 7 0 0 7 0	-do.- B3K	//	
	4 2 0 0 0 0 H T 1 7 0 0 3 0	-do.- B100K	//	
E	4 2 0 0 0 0 i A 0 8 4 4 0 0	Transistor 2SA844	トランジスター	
	4 2 0 0 0 0 i C 1 2 1 3 1 0	-do.- 2SC1213A C,D	//	
	4 2 0 0 0 0 i C 1 1 7 5 1 0	-do.- 2SC1175NP E,F,G	//	2SC1213A
	4 2 0 0 0 0 i C 1 9 1 8 0 0	-do.- 2SC1918 E,F,G	//	
	4 2 0 0 0 0 i C 1 9 1 7 0 0	-do.- 2SC1917 E,F,G	//	
F	4 2 0 0 0 0 i F 0 0 0 0 4 0	Diode 1S1555	ダイオード	
	4 2 0 0 0 0 i F 0 0 0 6 4 0	Zener Diode HZ-7B	ツェナーダイオード	
G	4 2 0 0 0 0 i G 0 0 0 3 9 0	IC $\mu$ PC577H	IC	
	4 2 0 0 0 0 i G 0 0 1 2 3 0	IC LA3350	//	
H	4 2 0 0 0 0 L B 4 0 0 3 1 0	Pin Jack PC-4P L-Type	ピンジャック	
I	4 2 0 0 0 0 K A 5 0 0 3 9 0	Rotary Switch SRZ-045	ロータリースイッチ	
	4 2 0 0 0 0 K A 8 0 0 2 9 0	Push Switch 2 $\times$ 4 SUE	フッシュSW	
	4 2 0 0 0 0 K A 8 0 0 2 6 0	-do.- 1 $\times$ 2 SUE	//	
	4 2 0 0 0 0 K A 8 0 0 2 8 0	-do.- 2 $\times$ 2 SUE	//	
J	4 2 0 0 0 0 L A 0 0 1 9 5 0	Antenna Terminal	アンテナ端子	
K	4 2 0 0 0 0 L A 0 0 1 2 8 0	Wire Lapping Pin	ラッピングピン	
L	4 2 0 0 0 0 P A 0 0 0 3 3 0	RF Pack FB118U14	RFハック	
38	3 2 0 0 0 0 C B 0 7 9 2 6 0	V.C Pulley	バリコンプーリー	CR-820, 1020,2020
39	3 2 0 0 0 0 A A 0 8 0 5 3 0	Dial Spring	ダイヤル スプリング	CR-450,820, 1020,2020
40	4 2 0 0 0 0 C B 0 7 7 0 7 0	Dial String	ダイヤル糸	
41	3 2 0 0 0 0 C B 0 7 7 9 4 0	Joint	ジョイント	CA-1010 CR-820,1020,2020
42	3 2 0 0 0 0 B A 0 6 9 8 4 0	Shaft	延長シャフト	CR-820
43	3 2 0 0 0 0 N A 0 6 9 2 2	Main C. Board, 1	メインシート1	R
	3 2 0 0 0 0 N A 0 6 9 1 8	-do.-	//	U,C
	3 2 0 0 0 0 N A 0 6 9 1 9	-do.-	//	B
	3 2 0 0 0 0 N A 0 6 9 2 0	-do.-	//	E
	3 2 0 0 0 0 N A 0 6 9 2 1	-do.-	//	A
A	4 2 0 0 0 0 F J 2 6 9 1 0 0	Electrolytic Capacitor 1000 $\mu$ 50V	ケミコン	
	4 2 0 0 0 0 F M 3 7 9 6 8 0	-do.- 6800 $\mu$ 50V	//	
	4 2 0 0 0 0 F M 1 1 6 1 0 0	Bipolar Electrolytic Cap. 1 $\mu$ 50V	バイポーラ ケミコン	
	4 2 0 0 0 0 F M 2 3 4 1 0 0	Ceramic Copacitor 500V 0.01 $\mu$	セラコン	
B	4 2 0 0 0 0 H Z 0 0 0 8 7 0	Fire-Proof Resistor 1W0.22 $\Omega$	不燃性抵抗	
	4 2 0 0 0 0 H Z 0 0 0 7 1 0	-do.- 1W4.7 $\Omega$	//	

Ref. No.	Part No.	Description	Remarks	Common Models
	4 2 0 0 0 0 H L 6 1 6 1 5 0	Metal Oxide Film Resistor 1W 1.5K $\Omega$	酸化抵抗	
	4 2 0 0 0 0 H L 6 1 6 3 9 0	Metal Oxide Film Resistor 1W 3.9K $\Omega$	//	
	4 2 0 0 0 0 H L 4 2 4 1 0 0	-do.- 2W 10K $\Omega$	//	
	4 2 0 0 0 0 H L 4 2 6 2 2 0	-do.- 2W 2.2K $\Omega$	//	
	4 2 0 0 0 0 H L 4 2 6 3 9 0	-do.- 2W 3.9K $\Omega$	//	
	4 2 0 0 0 0 H L 6 2 6 2 2 0	-do.- 2W 2.2K $\Omega$	//	
	4 2 0 0 0 0 H W 1 0 4 2 2 0	Fuse Resistor 150mA 22 $\Omega$	ヒューズ抵抗	B,E
	4 2 0 0 0 0 H Z 0 0 0 0 2 0	Metal Film Resistor 2W 0.22 $\Omega$	金属板抵抗	
	4 2 0 0 0 0 H Z 0 0 0 0 3 0	-do.- 2W 0.47 $\Omega$	//	
	4 2 0 0 0 0 H M 0 5 5 1 0 0	Cement Molded Resistor 5W 100 $\Omega$	セメント抵抗	
	4 2 0 0 0 0 H T 1 7 0 0 5 0	Variable Resistor B5K	半固定抵抗	
C	4 2 0 0 0 0 i A 0 8 4 4 0 0	Transistor 2SA844	トランジスター	
	4 2 0 0 0 0 i A 0 5 6 0 0 0	-do.- 2SA872	//	
	4 2 0 0 0 0 i B 0 5 4 4 0 0	-do.- 2SB544	//	
	4 2 0 0 0 0 i B 0 5 6 0 0 0	-do.- 2SB560	//	
	4 2 0 0 0 0 i C 0 4 5 8 8 0	-do.- 2SC458B,C	//	
	4 2 0 0 0 0 i C 1 9 1 8 0 0	-do.- 2SC1918E,F,G	//	
	4 2 0 0 0 0 i D 0 2 3 4 0 0	-do.- 2SD234R,O,Y,G,R	//	
	4 2 0 0 0 0 i D 0 4 0 0 0 0	-do.- 2SD400	//	
	4 2 0 0 0 0 i D 0 4 3 8 0 0	-do.- 2SD438	//	
D	4 2 0 0 0 0 i F 0 0 0 0 4 0	Diode 1S1555	ダイオード	
	4 2 0 0 0 0 i H 0 0 0 2 4 0	-do.- 1S1885	//	
	4 2 0 0 0 0 i H 0 0 0 5 6 0	-do.- 30DC1	//	
	4 2 0 0 0 0 i H 0 0 0 5 7 0	-do.- 30DC1R	//	
	4 2 0 0 0 0 i H 0 0 0 4 7 0	-do.- 1D4B1	//	
	4 2 0 0 0 0 i F 0 0 0 5 5 0	Zener Diode HZ12C	ツェナーダイオード	
	4 2 0 0 0 0 i F 0 0 0 6 6 0	-do.- HZ30	//	
E	4 2 0 0 0 0 G D 9 0 0 2 1 0	Coil 2 $\mu$ H	コイル	
F	4 2 0 0 0 0 K C 0 0 0 0 8 0	Relay HC-2P	リレー	R,B,A,E
	4 2 0 0 0 0 K C 0 0 0 3 5 0	-do.- HC-2P AP34219	//	U,C
G	4 2 0 0 0 0 L B 2 0 0 9 0 0	Fuse Holder Pin	ヒューズホルダーピン	R,U,C,A
	4 2 0 0 0 0 L B 2 0 1 0 6 0	-do.-	//	E,B
H	4 2 0 0 0 0 L B 3 0 0 4 0 0	Transistor Socket	トランジスターソケット	
I	4 2 0 0 0 0 L A 0 0 1 2 8 0	Wire Lapping Pin	ラッピングピン	
J	4 2 0 0 0 0 K B 0 0 0 3 3 0	Fuse 250V 1.0AT	ヒューズ耐ラッシュ	R,A
	4 2 0 0 0 0 K B 0 0 1 0 6 0	-do.- UL 250V 1.0AT	ヒューズUL	U,C
	4 2 0 0 0 0 K B 0 0 0 7 3 0	Miniature Fuse 250V 1.0AT	Ⓢヒューズ	E,B
	4 2 0 0 0 0 K B 0 0 0 2 2 0	Fuse 125V 1.5AT	ヒューズ	R,A
	4 2 0 0 0 0 K B 0 0 1 0 4 0	-do.- UL 250V 3A	ヒューズUL	U,C
	4 2 0 0 0 0 K B 0 0 0 6 8 0	Miniature Fuse 250V 1.25AT	Ⓢヒューズ	E,B
K	3 2 0 0 0 0 B A 0 6 9 7 3 0	Radiator	放熱板	CR-820,1020,2020
L	3 2 0 0 0 0 B B 0 6 3 0 8 0	TR-Pusher	TRフッシャー	CA-1010,CR-820,CR820,1020,2020
M	3 2 0 0 0 0 C B 0 6 9 4 8 0	Wire Supporter No.37	ワイヤークリップ	CR-311,CR-820
N	3 2 0 0 0 0 C B 0 7 3 9 2 0	Lead Crimper No.435	リードクランパ	CR-311,CR-820
O	4 2 0 0 0 0 K A 8 0 0 3 4 0	Push Switch 2 $\times$ 2 SUE 1A	プッシュSW 2連, 2回路	
P	4 2 0 0 0 0 L A 0 0 0 5 3 0	Eyelet With Wing	羽根付ハトメ	E,B

U.S. & CANADIAN MODELS

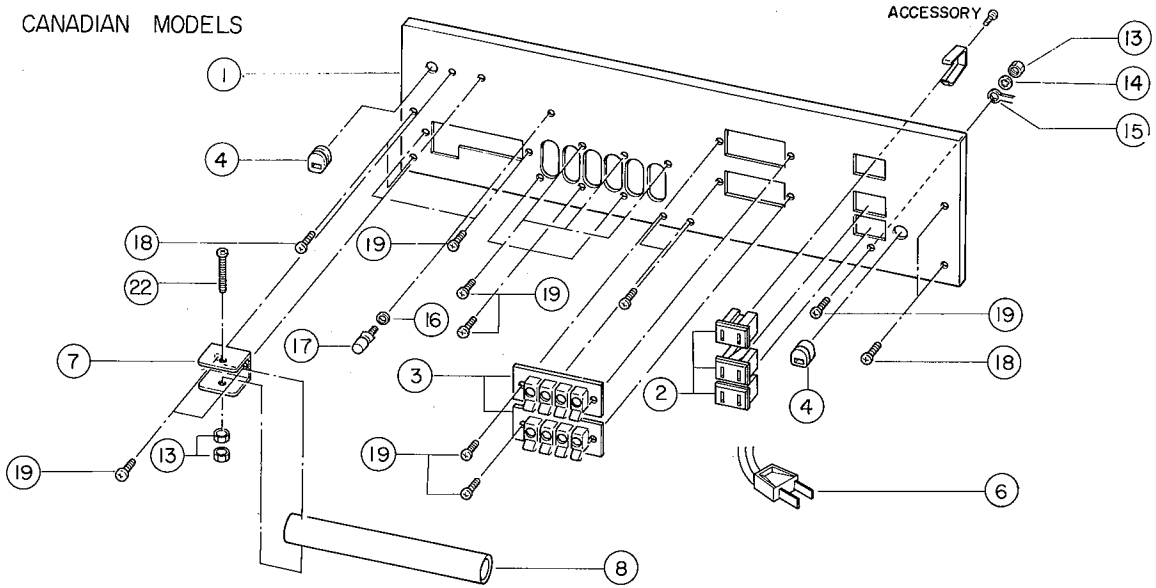

BRITISH & AUSTRALIAN MODELS

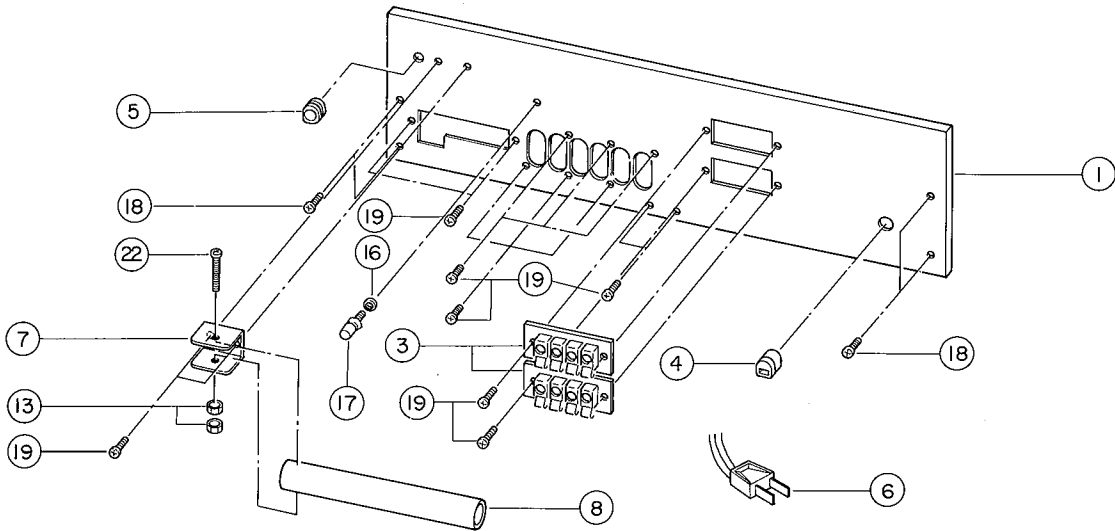

EUROPEAN MODEL

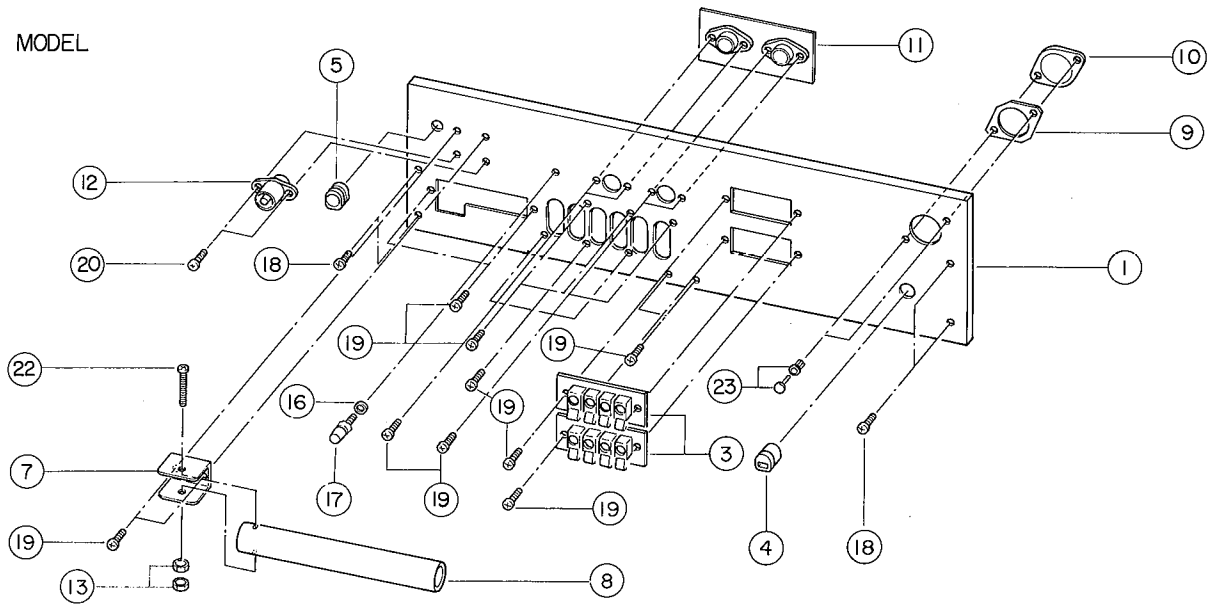

Ref. No.	Part No.		Description	Remarks	Common Models
1	3 2 0 0 0 0	A A 0 8 5 2 4 0	Rear Panel, U	リアパネル	U
	3 2 0 0 0 0	A A 0 8 5 8 5 0	-do.- C	//	C
	3 2 0 0 0 0	A A 0 8 5 2 5 0	-do.- A	//	A
	3 2 0 0 0 0	A A 0 8 5 2 6 0	-do.- E	//	E
	3 2 0 0 0 0	A A 0 8 5 4 3 0	-do.- B	//	B
2	4 2 0 0 0 0	L B 2 0 0 7 1 0	AC Socket S-1642B	ACコンセント	R,U,C
3	4 2 0 0 0 0	L A 0 0 1 9 4 0	4P Push Terminal	4Pプッシュターミナル	
4	4 2 0 0 0 0	C B 0 6 8 6 3 0	Cord Stopper SR-3P-4	コードストッパー	R,U,C
	4 2 0 0 0 0	C B 0 7 0 6 9 0	-do.- EA-5	//	E,A,B
5	3 2 0 0 0 0	C B 0 6 2 7 8 0	Rubber Spacer	ゴムブッシュ	R,A,E,B
6	4 2 0 0 0 0	M G 0 0 0 3 4 0	AC Cord Pot-64	ACコード	R,U,C
	4 2 0 0 0 0	M G 0 0 0 5 0 0	-do.- SA-1	//	A
	4 2 0 0 0 0	M G 0 0 0 2 9 0	-do.- #1272	//	E
	3 2 0 0 0 0	M Z 0 6 7 8 4 0	AC Cord Assy For BS	//	B
7	3 2 0 0 0 0	A A 0 7 6 9 7 0	Antenna Holder	アンテナホルダー	
					CR-820, 1020, 2020
8	4 2 0 0 0 0	G E 0 0 0 1 0 0	AM Bar Antenna	AMバーアンテナ	
					CR-820
9	3 2 0 0 0 0	C B 0 7 6 5 6 0	Isolation Plate For Voltage Selector	VS絶縁板	E
					CA-800 II CR-820, 1020, 2020
10	4 2 0 0 0 0	L B 2 0 0 2 6 0	Voltage Selector SWP033-3023	電圧切換器	R,E
					CR-820
11	3 2 0 0 0 0	N A 0 6 9 2 4 5	Tuner C. Board, 5	チューナーシート5	E
A	4 2 0 0 0 0	L B 5 0 0 1 9 0	DIN Socket	DINコネクター	E
					CR-820
12	4 2 0 0 0 0	L B 2 0 0 1 5 0	75Ω Coaxial Cable Socket	同軸コネクターソケット	E
					-do.-
13	4 2 0 0 0 0	E V 1 0 0 3 0 0	Hexagonal Nut M3 FCM3-BI	六角ナット	
14	4 2 0 0 0 0	E V 4 1 0 0 3 0	Toothed Locked Washer 3S ZMC2-Y	歯付座金	U,C
15	4 2 0 0 0 0	L A 0 0 0 2 8 0	Lug Terminal, Earth 3MM	アースラグ	U,C
16	4 2 0 0 0 0	E V 9 0 1 3 6 0	Toothed Locked Washer φ3.6 FNM3-3g	セスム平座金	
17	4 2 0 0 0 0	L A 0 0 1 0 7 0	Earth Terminal	アース端子	
18	4 2 0 0 0 0	E Z 4 3 0 0 8 0	Bonding Tapping Screw 3×8 FCM3-BI	ボンディングタッピングネジ	
19	4 2 0 0 0 0	E i 4 3 0 0 8 0	Binding Tapping Screw 3×8 FCM3-BI	バインドタッピングネジ	
20	4 2 0 0 0 0	E J 4 2 6 0 8 0	Pan Head Tapping Screw 2.6×8 FCM3-BI	ナベタッピングネジ	E
21	4 2 0 0 0 0	E D 4 3 0 0 8 0	Binding Head Screw 3×8 FCM3-BI	バインド小ネジ	
22	4 2 0 0 0 0	E A 4 3 0 2 5 0	Pan Head Screw 3×25 FCM3-BI	ナベ小ネジ	
23	4 2 0 0 0 0	C B 0 6 8 8 8 0	Plastic Rivet φ3.5	プラスチックリベット	R,E

# PACKAGE

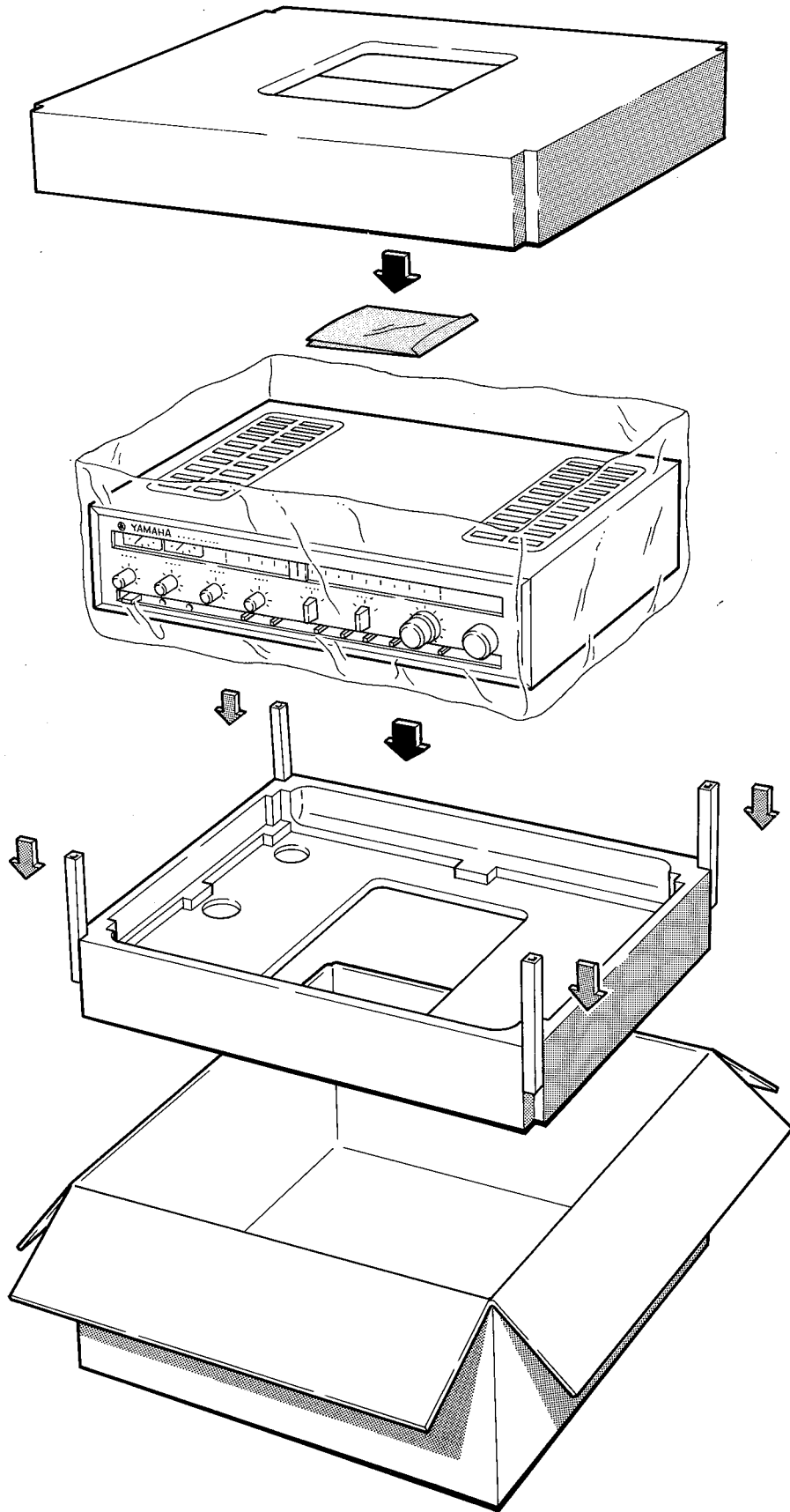

# SCHEMATIC DIAGRAM BY EXPORT ZONE

## USED FUSE

MODEL	F803	F804	FR801
GENERAL	1.5AT 250V		Jumper
US & CANADIAN	1.5AT 250V	1.5AT 250V	-do.-
UK	3.0A 250V		-do.-
EUROPEAN	1.25AT 250V	1.25AT 250V	22Ω/150mA
AUS-TRALIAN	1.25AT 250V		-do.-

## UK model

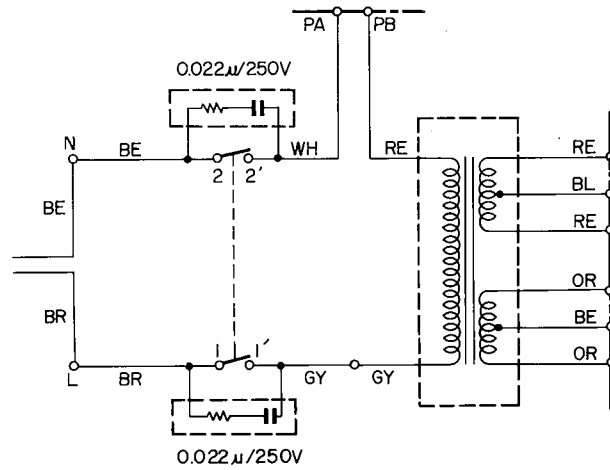

## POWER SUPPLY CIRCUIT GENERAL EXPORT model

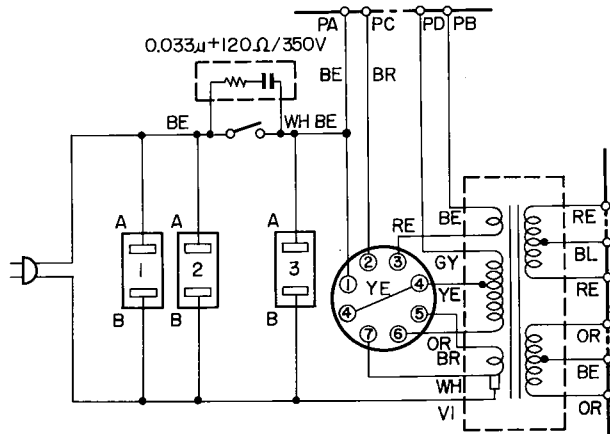

## EUROPEAN model

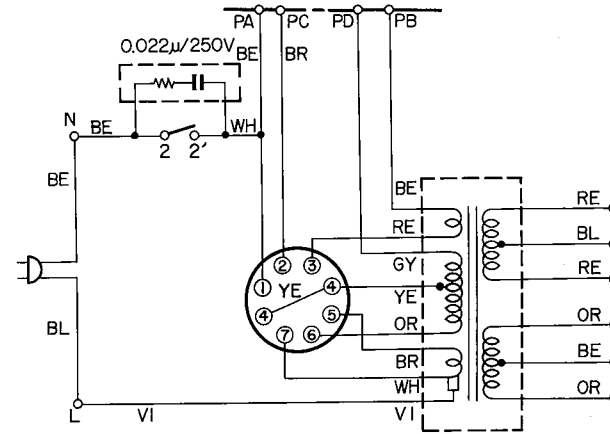

## US & CANADIAN model

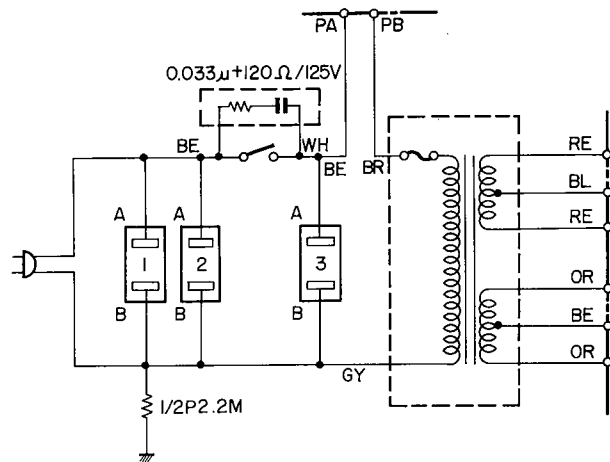

## AUSTRALIAN model

