

# State of Charge V5 (SoC) Meter User Guide

PLEASE READ ENTIRE GUIDE BEFORE INSTALLATION OR ANY POWER-UP ATTEMPT



Lithionics Battery LLC

## **Description:**

The Lithionics Battery SoC meter is designed to track battery state of charge (percent of usable energy left in the battery) as well as other useful data variables. Tracking state of charge is accomplished by an internal, high sensitivity hall-effect sensor. SoC meter data will only be correct if the configuration variables are set correctly, which are pre-set initially by Lithionics Battery, but user adjustable with supporting hardware. If they are ever accidentally modified a record of the default values is included in this manual for your reference. It will also track and display live amperage (A), live wattage (W), battery voltage (V Pk), temperature (F/C), amp hours (Ah), watt hours (Wh), etc. The meter will be most accurate if the battery is fully charged on a regular basis. If the battery is always partially charged then the SoC meter reading may drift long term and will become less accurate. **When the most accurate measurements are required it is recommended to perform a full charge weekly.**

## **Description (continued):**

The Lithionics Battery SoC Meter system is comprised of the main SoC sending box for collecting and computing data points. List of accessories for the SoC Sending Box:

- Round SoC Display Gauge Pod
- Bi-Directional Serial ASCII Data Formats:
  - USB
  - RS232 via DB9
  - TTL/UART
  - Bluetooth V2.1
  - Bluetooth V4.0
  - Ethernet TCP/IP Tunnel
- Analog (0-5V) output (SOC%)
- 3-Bit Register
- Generator Control Module
- CANbus 2.0B

## Index:

- **Initial Installation** Pages 4-5
- **Using SOC Interface Display** Page 6
- **Programming Menu** Pages 7-10
- **Input/Output Accessories (Optional)**
  - **Basic Analog/Digital Outputs** Page 11
  - **3 Bit Register** Page 12
  - **Generator Control Module** Page 13
- **Serial Data Outputs**
  - **USB/DB9-RS232** Page 14
  - **Bluetooth Serial Data** Page 14
  - **Ethernet TCP/IP Interface** Page 14
    - **TCP/IP Configuration Device** Page 15
    - **TCP/IP Physical Interface** Page 16
  - **PLC Data Format** Page 17
  - **CSV Data Format** Page 18
- **Serial Data Bi-Directional Communication** Pages 19-20
- **CANbus 2.0B** Page 21-22
- **Default Battery System Values** Page 23

## Initial Installation:

Upon unpacking please inspect all components for obvious damage due to shipping. The SoC Sending Box has BATTERY +, LOAD +, and a SoC NEGATIVE REFERENCE WIRE which must be connected correctly for accurate SoC calculation. Please refer to the chart and instructions below.

1. Begin by turning off ALL LOAD devices both charging and discharging. Turn the battery off, or if it is equipped with an external NeverDie unit, turn it off as well.
2. Connect the SoC NEGATIVE REFERENCE WIRE to the battery negative (-) terminal.
3. Connect the battery positive + to the BATTERY + on the SoC Sender Box.  
**NOTE: If you have an external NeverDie unit on your battery system the Load + of the NeverDie must be connected to the Battery + on the SoC Sender Box.**
4. Connect the LOAD + to your charge and discharge loads (ideally a common bus bar).
5. Connect any accessories you may have ordered with your SoC Meter system.
6. Power the battery or NeverDie unit back on.
7. To calibrate the SoC Meter to the batteries actual SOC%, please allow 1 charge cycle to complete fully.
8. Installation complete.

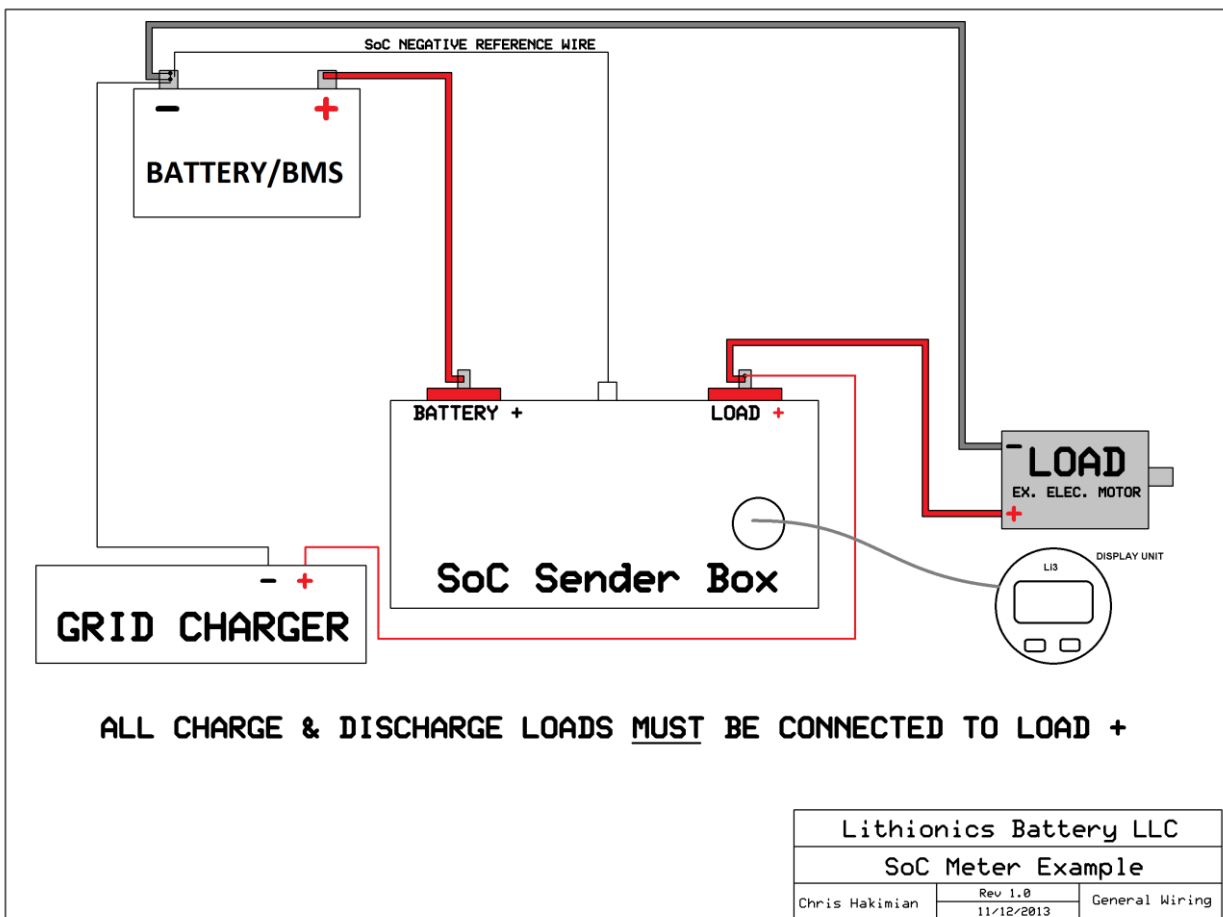

## Weather Resistant Display Port Connection:

When connecting the SoC Display via the weather resistant port on the front of the sender unit it is especially important to pay special attention to the screw down connector.

1. Locate the two indentations highlighted in green below.

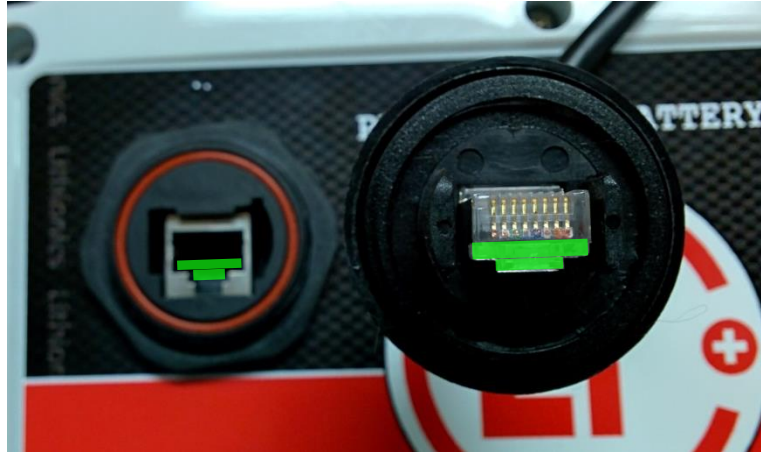

2. Connect the screw connector to the panel interface with the two highlighted indentations mating with each other.
3. While pressing the ring down lightly, rotate the ring counter-clockwise until you feel a light click. This aligns the ring threading with the panels mating threads.



4. Now turn the ring clock-wise to begin screwing the ring down. Keep note of any excess friction which may indicate it is being cross-threaded. If this occurs stop immediately, unscrew the ring and start over. Inspect the ring to be “square” compared to the panel.

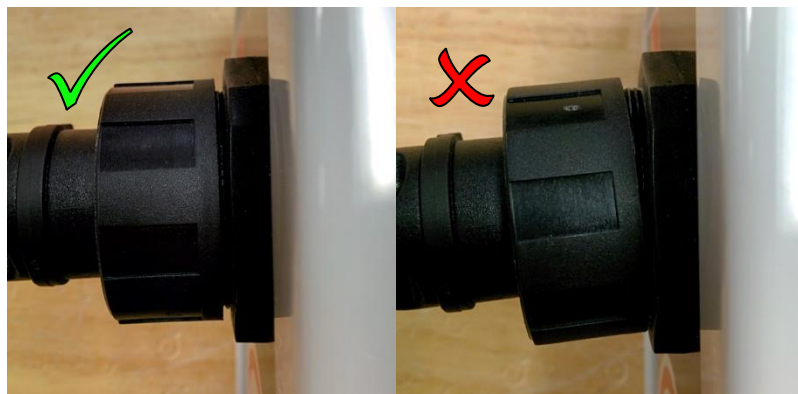

## Using The SoC Meter's Interface via SoC Display Unit:

The SoC meter has a dual line LCD screen capable of showing 2 pieces of data independently. Pressing the upper button scrolls through available data on upper line, pressing lower button scrolls through available data on the lower line. Any combination of data is possible on these 2 lines. The following list explains all available data counters:

**E■■■■■■F** – Graphical representation of the Fuel Gauge. Each of the 6 bars corresponds to approximately 17% of capacity.

**100% Fuel** – Percentage of digital Fuel gauge. Fuel is derived from SoC minus the Low Fuel setting explained in the Calibration/Settings section below.

**100% SoC** – State of Charge. The percent of usable energy left in the battery.

**23.4 A** – Amperage. Instant current reading. A “+” sign in front of the value indicates charging current. No sign indicates discharging current.

**20000 W** – Instant Wattage reading. This power value is derived by multiplying current and voltage. This is useful to estimate how much instant power is passing through the battery circuit. This value can be manually converted to horse power by the formula:  $\text{Watts}/745.7=\text{HP}$

**39.6 V Pk** – Pack voltage reading.

**82F Tmp** – Instant temperature reading at the sender board location. Can be set to C or F. See “Zero-Point Calibrations and Settings” section.

**100.0 Ah** – Remaining Amp Hour capacity of the battery.

**3960 Wh** – Remaining Watt Hour capacity of the battery. Watt Hour value is derived by multiplying the Amp Hour value and the Pack Voltage together. This value will be changing dynamically as voltage fluctuates with load.

## Programming Menu via SoC Display Unit:

The SoC meter's Programming Menu is where you can enter constant settings. Although the defaults are pre-loaded at the factory, you will need to access this menu to make minor changes or if you are using the SoC meter on a different battery. It is also useful for fine tuning for your application. It is very important these are entered accurately or SoC calculation will be inaccurate.

To enter the Programming Menu, locate the 2 SoC Meter Display input buttons.

Press and hold both buttons simultaneously for 6 seconds.

The SoC Meter will enter the Programming Menu.

-Press the upper button to scroll through the range of values.

-Press lower button to lock the value and move to the next screen.

**NOTE: If no button(s) are pressed within 20 seconds then Setup Mode will time-out and switch to display mode automatically.**

Below is the listing of all setup screens and their variable descriptions. The factory default values are recorded for you at the end of this document for your reference.

**V Range** – Voltage Range. Set this to your maximum voltage range. There are 2 ranges available, “to 64V” and “to 340V”. For example, if your battery reaches max voltage of 43.2V at the end of charge, then use “to 64V” range setting.

**Ah PackSize** - Battery pack capacity. Settings are from 1Ah to 3000Ah. 0-50Ah are in 1 Ah increments. 50Ah-3000Ah are in 10Ah increments.

**Full Vlt** – Full Voltage. Set this to the maximum voltage your battery reaches at the end of charge. This will be used to sync the meter's 100% SoC reading when the battery reaches this voltage level. Typically this value is 3.65V per cell. So a 12V (4 cell) battery is  $4 \times 3.65 = 14.6V$ , subtract .2V for charger accuracy tolerance = 14.4V full voltage setting. You may also calculate your maximum voltage by the following table:

Nominal Voltage	Full Voltage Setting
12.8V AKA "12V"	14.4V
16V	18.0V
25.2V AKA "24V"	29.0V
38.4V AKA "36V"	43.6V
51.2V AKA "48V"	58.2V
64.0V	72V
76.8V AKA "72V"	87V
89.6V	102V
102.4V AKA "96V"	116V

**Min SOC** – Minimal State Of Charge. This percentage value sets the “Empty Fuel Tank” level, so the driver can go by a Fuel Gauge reading and not completely deplete the battery, to preserve its lifecycles. For example, if this value is set to 20%, then Fuel Gauge will report 0% when SoC is still at 20%. If you desire to use your battery to its full capacity and/or want the Fuel Gauge to reflect true SoC, then set this value to zero.

In addition, when LVC is set to 1, this setting will turn battery off at the programmed SOC%. Example: Min SOC is set to 20% with LVC=1, during discharge when SOC% = 20% the battery will automatically turn off when it reaches 20% SOC **OR** 3.0V/cell, whichever comes first. This allows a “reserve” of energy to be saved when desire. By pressing the RESET button for 1 second the battery will turn back on and allow further discharge to 0% SOC.

**CurrDir** – Current Direction. Hall-effect sensor reports direction of DC current passing through the sensor. It’s important for correct SoC meter functionality that the current is sensed in the correct direction for charge/discharge. If this is set opposite you will see the gauge reporting charging when you’re discharging and vice versa. In this case please reverse the setting. Current should be reporting with a “+” sign during charge and without any sign during discharge.

**TempComp** – Temperature Compensation. At low temperatures batteries cannot supply their entire capacity due to slowdown of electrochemical processes. This percentage value reduces Fuel Gauge reading based on temperature drop, linearly from 25C to 0C and below, such that Fuel Gauge reduction is equal to this value at 0C ( freezing point ). For example, if you set this to 10% (the recommended value for Lithionics Battery cells), then the Fuel Gauge will report 10% less capacity at 0C, linearly changing across a wide temp range. This value only effects Fuel Gauge reading, SOC reading still remains true to battery capacity regardless of the temperature.

**Low Fuel** – Low Fuel level. This percentage value determines the minimal Fuel Gauge level at which the “Low Fuel” circuit is triggered. This is used for external signaling, such as OEM dash boards, generator/charger relay, etc. On most setups this is not used and should be skipped.

**TempUnit** – Temperature Units. Set this to Fahrenheit (F) or Celsius (C).

**ChargeEff** – Charging Efficiency. This percentage value slows down rate of SoC climb during the charge to compensate for battery losses during discharge. Recommended setting is 96%. This would be much less for Lead Acid batteries, depending on their Peukert value and battery application. For example, in electric vehicles with high discharge rates, Peukert effect is more pronounced, so this value must be set lower to more accurately report SoC and Fuel Gauge values during partial charges. This setting must be tuned experimentally for best accuracy. Ideal setting will cause SoC to reach 100% at approximately the same time as charger is finishing up the full charge.

**NOTE:** This feature assumes that Pack Size is set to actual useful capacity of the battery at high C rates, which is almost true for LiFePO4 cells, but not for Lead Acid batteries. Lead Acid battery will have smaller useful capacity than its rated capacity, so Pack Size should be set to useful capacity, so the SoC meter can reflect meaningful Fuel Gauge.

**DeadZone** – Dead Zone. In some cases when temperature fluctuations are wide and fast, SoC meter might show non-zero current reading when not expected. This is due to imperfect temperature stability of hall-effect sensors. The SoC meter software compensates for this, but in some extreme situations it may fluctuate resulting in small current reading when not expected. Dead Zone allows ignoring small current readings when they are likely false (when small reading starts after zero reading). During charging, when current is dropping during CV phase the SoC meter will count it even in the Dead Zone. If small reading persists for over 60 minutes, it will be considered as false reading and thus ignored.



You can turn off this feature by setting this value to zero. Default 0.3A is recommended for best zero reading stability.

**TestMode** – Test Mode is designed for verification of external circuits at the factory. This can be useful for testing outputs trigger settings as it will slowly cycle SOC% down and back up repeatedly.

**Out Mode** – Controls the function of the optional output terminals. Default mode = 0 and is common for most setups. Mode 1 turns the optional output terminals into a 3 bit register. The 3 bit register signals SOC level in 8 binary values between 000 and 111.

**SensType** – Sensor Type. This is the hall-effect sensor type which is installed and set at the factory. Options are 1000A or 2000A. Refer to the default values at the beginning of this user guide.

**CurScale** – Current Scale. This function is used to modify the amps counted by the internal hall-effect sensor. It is useful if you notice that the SoC reading is too high or too low. It can be adjusted +/- 5.00%

**IdleLoad** – Idle Load (mA). This setting represents the constant idle load current powering the SoC Meter and BMS system. This can be measured with a digital multi-meter in DC amperage mode in series with the SoC NEGATIVE REFERENCE WIRE. Allowed range is 0mA – 200mA.

**Cell Count** – This setting must be set to the number of cells in series. Example: 12V battery = 4, 24V battery = 8, 36v battery = 12, etc.

**Low Voltage Cutoff** – Enable (1) or Disable (0) low voltage cutoff, AKA battery reserve.

**Calib..?** – Calibrate Zero Point

This function performs a “zero-point” calibration. This is called a “zero-point” calibration because the current flowing in or out is at zero state. Before performing this operation, you must ensure that the battery is disconnected from any loads both charging and discharging so current is not flowing in or out of the battery. Failure to do so will cause the SOC meter to have an inaccurate zero-point calibration!

Setting this to Yes will perform the zero-point calibration when the enter button is pressed. It takes a few seconds to determine the zero-point current levels so that the current sensor can properly distinguish current direction and value. It's critical that there is no current flowing in or out of the battery at this point. It's recommended to disconnect any loads both charging and discharging from the battery before entering zero-point calibration. There is no input on this screen, once the zero-point calibration is complete the meter will automatically return to normal user mode.

## Input/Output Accessories (Optional)

### Basic Analog and Digital Outputs:

NOTE: Outputs #1-3 are CMOS level 0-5V with 5mA limit.

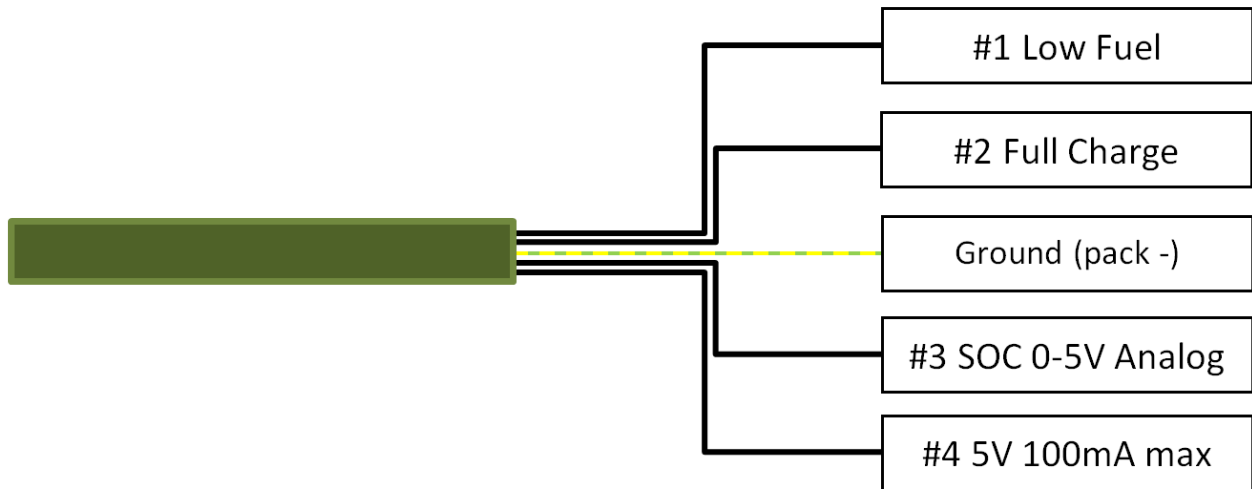

**#1 Low Fuel** - The Low Fuel output circuit is 0V when inactive and 5V when active. It corresponds to the Low Fuel setting in the user menu.

**#2 Full Charge** - The Full Charge output circuit is 0V when inactive and 5V when active. It corresponds exclusively to 100% SOC condition.

**#3 SOC 0-5V Analog** - The SOC 0-5V Analog circuit represents 0%-100% SOC state. It will linearly increase/decrease voltage according to SOC% state.

**#4 5V 100mA max** - A 5V reference voltage, 100mA max.

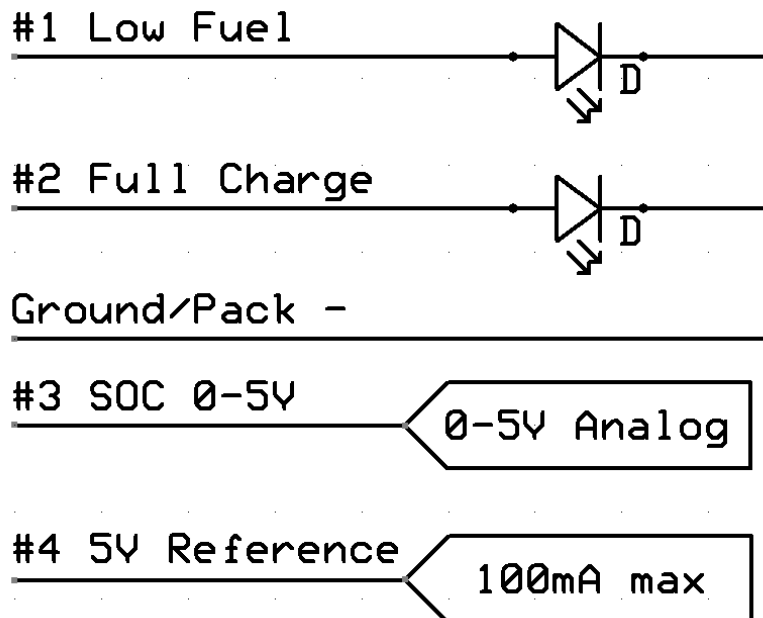

### **3 Bit Register Output:**

4 wires represent a 3 bit register. Outputs #1-3 represent a 3 bit register with binary output for SOC %.

Outputs #1-3 goes 0-5V binary 0 or 1. Out3 is least significant bit (LSB). Out 1 is most significant bit (MSB).

SOC =100%, all 3 bits are high

SOC=0% all 3 bits low

SOC <100% and >0% 3 bits represent binary values 0-7, each step corresponding to approx. 15% SOC increment.

## Generator Control Module Interface (AKA Fischer Panda Controller)

The Generator Control Module Interface is designed to work with generators that accept a closed circuit start/open circuit stop signal such as in Fischer Panda generators. This module will automatically start and stop the generator, as well as require a confirmation signal from the generator that it is running. If the generator is not running once signaled to start, the alarm circuit will trigger alerting you to a generator fault. In addition to this a momentary button can be short pressed by the user to reverse the generators state at any time. This allows convenience/opportunity charging along with automatic charging start/stop functionality.

The start and stop points of the generator can be user programmed as follows:

**Low Fuel** – When the SoC Meter is at the low fuel level (see page 7 Low Fuel) it will trigger the generator to start automatically.

**Full Voltage** – When SOC full voltage is reached (see page 6 Full Vlt) the SOC meter calibrates to 100% and the generator is commanded to turn off.

There are 3 pairs of wires that need to be connected for the Generator Control Module to interface correctly with the generator. They are:

**Alarm** – 2 wire isolated 2 amp 250V max N/O circuit (closes when active, opens when inactive).

**Start** – 2 wire isolated 2 amp 250V max N/O circuit (closes to start generator, opens to stop)

**Run** – 2 wire isolated input circuit. A 12V-24V max signal is expected from generator when the generator has started. There can be up to a 2 minute delay between start signal and return run signal, if not the Alarm circuit will activate. Alarm signal is reset when Run signal is detected or Start signal is removed.

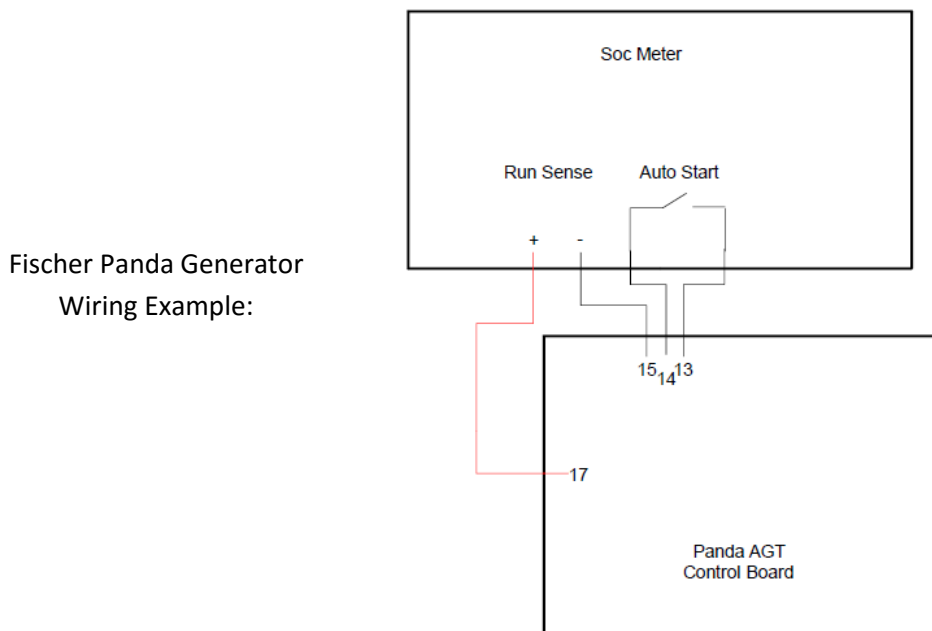

## **Serial Data Output**

Serial data output is supported over either a USB, TTL UART, DB-9 RS232, and Bluetooth interface.

The USB interface emulates a virtual COM port. ASCII serial stream data is broadcast via USB or Serial DB9. Any terminal program that can view/record serial data via a COM port is compatible. At Lithionics we use the program “Putty.exe” to log and display data in real time (available at [putty.org](http://putty.org)). This fixed length data line is updated once every second. The file is saved real time, viewable as plain text in a .log file. This data can be integrated into other applications that can read data via a COM port.

### **COM Port Settings:**

<b>Speed/Baud</b>	<b>9600</b>
<b>Data bits</b>	<b>8</b>
<b>Stop bits</b>	<b>1</b>
<b>Parity</b>	<b>None</b>

## **Bluetooth Serial Data**

The Bluetooth module will output the same fixed length data stream as the serial data output above at the same 1 second time interval. The default pairing password is “1234”.

On a windows PC this will create a virtual serial port.

On an Android device this can be accessed within an app such as BlueTerm, a free Bluetooth terminal app in the play store.

Serial Bluetooth data is blocked on iOS devices.

### **Ethernet TCP/IP Interface:**

TCP/IP interface supports Auto Negotiation (Full/Half duplex and 10/100 Mb speed). Data is transmitted over UDP socket in a text string with CR+LF termination.

Default IP configuration is as follows:

IP Address – 192.168.0.254

Subnet Mask – 255.255.255.0

Gateway – 192.168.0.1

Destination IP – 192.168.0.255 (broadcast to local LAN)

Source Port – 48879 (0xBEEF)

Destination Port – 65261 (0xFEED)

## **Serial-Ethernet TCP/IP Gateway Configuration Device:**



Serial-Ethernet Gateway Configuration device (**Lithionics Part# 50-196**) can be used with a Windows PC to communicate with SOC Gauge over crossover RJ45 cable, to avoid connecting SOC Gauge to office LAN, which might have different IP addressing, and also to allow use of simple serial terminal for configuration, rather than writing custom software to handle UDP socket communications. The device has USB Serial port based on common FTDI chipset, so it's recognized as a COM port by

Windows host. Terminate is a freeware terminal software ([http://www.compuphase.com/software\\_terminate.htm](http://www.compuphase.com/software_terminate.htm)) which is well suited for configuration purposes as it allows to send complete string rather than one character at a time as most programs do. Once SOC Gauge is configured with desired IP addressing it can be connected to live network for real time data processing.

Serial-Ethernet Gateway device has following IP configuration, which cannot be changed:

- IP Address – 192.168.0.2
- Subnet Mask – 255.255.255.0
- Gateway – 192.168.0.1
- Destination IP – 255.255.255.255 (broadcast to ALL)
- Source Port – 0xFEED
- Destination Port – 0xBEEF

Such configuration allows communication with SOC Gauge which may have unknown IP address, so we can reset it to factory default and reconfigure it as needed.

Serial-Ethernet Gateway collects string of data from Serial port until CR+LF termination is received, then wraps into UDP packet and sends to Ethernet port. At the same time it listens for UDP packets, strips them into string data and passes back to Serial port.

**Battery Module Ethernet TCP/IP Physical Interface:** Typically the physical interface is a M12 D-Coded connector which is an industrial weather resistant standard for RJ45 Ethernet connection.

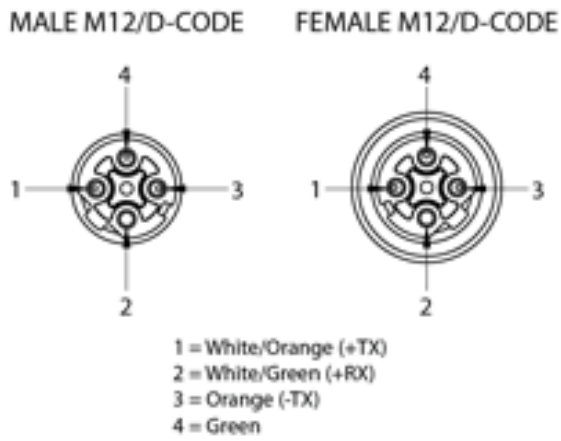

## **PLC (Programmable Logic Controller) Data Formatting:**

There will be a continuous stream of data packets with 1 second time interval between packets. Each data packet is an ASCII string of 45 characters, containing 10 data fields. Each field starts with label character and follows by decimal numeric data of constant length, padded by leading zeroes. Each string is terminated by carriage return (CR) and line feed (LF) characters, bytes 0D and 0A.

### **Example of Data packet:**

B1H00000V000F000S000D0A00000W000000T000R00000

### **Data packet fields:**

- B** – Battery address, typically 1, in multi-battery systems this will represent battery order – 1 digit long
- H** – AmpHours remaining, in 0.1Ah resolution, i.e. 123 = 12.3Ah – 5 digits long
- V** – Volts, in 0.1V for LV systems (12V-64V) or 1V resolution for HV systems (64V+), i.e. 123 =12.3V – 3 digits long
- F** – Fuel Gauge, in percent, i.e. 100 = 100% - 3 digits long
- S** – SoC percent, in percent, i.e. 100 = 100% 3 digits long
- D** – Current direction, 1 – charging, 0 – discharging – 1 digit long
- A** – Amps live, in 0.1A resolution, i.e. 123 – 12.3Amp – 5 digits long
- W** – Watts instant, in 1W resolution, i.e. 20000 = 20000W – 6 digits long
- T** – Temperature, in degrees, units depend on setup parameter – 3 digits long
- R** – Reserved for future use. Last byte is defined in “Battery State” on page 20.



# CSV (Comma Separated Values) Data Formatting:

## Data Display Through Putty Using USB/Serial DB9 Interface:

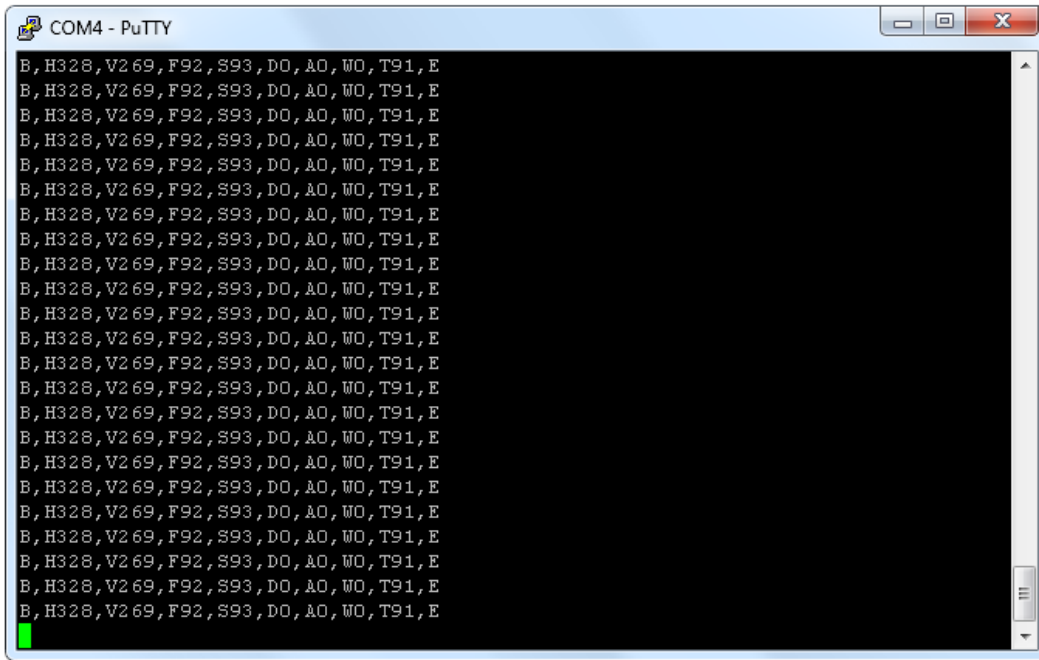

### CSV Line Definitions:

RAW Code:	<u>B</u>	<u>H328</u>	<u>V269</u>	<u>F92</u>	<u>S93</u>	<u>D0</u>	<u>A0</u>	<u>W0</u>	<u>T91</u>	<u>E</u>
Measured Unit:	Begin	Amp Hours	Voltage	Fuel %	State Of Charge %	Current Direction (Charge1 Discharge0)	Amps	Watts	Temperature	End
Translated:	Begin	32.8 Ah	26.9V	92% Fuel	93% SOC	Discharging	0 Amps	0 Watts	91F	End

## **Serial Data Bi-Directional Communication:**

**Entering Setup Mode:** Upon initial power up SOC Gauge will be in data mode, so it will be sending battery data according to its stored configuration. You can ignore this data and type in following command and then press Enter to send it – **AT+SETUP**. If command is accepted the unit will respond with **OK** and will stop sending data, expecting next set of AT commands. Below is the listing of all commands. You don't have to send all commands, only those which require changes to corresponding parameters. Once all changes have been sent, complete setup by sending command – **AT+END**

**NOTE:** When using Ethernet TCP/IP interface, once in setup mode SOC Gauge will reset its IP configuration to default listed on page 14, so it can communicate with Serial-Ethernet Gateway. It still stores previously configured IP parameters and will revert to them once exited out of setup mode back to data mode. This feature allows communication with SOC Gauge even when its stored IP parameters are unknown or invalid, but requires use of Serial-Ethernet Gateway with crossover cable, to ensure matching IP parameters during setup mode.

When using IP settings that are different than defaults listed on page 14 polling data will **NOT** be received via Ethernet TCP/IP configuration interface. Although polling data is not received, BMS will still respond to Setup mode and Data Mode Commands listed below.

**List of all AT commands:** Commands listed below must be followed by new value after “=” sign. If new value is outside of expected range, error message will be sent. If new value is accepted, OK message will be sent as confirmation. For example, sending command AT+AH=100 will set Pack AmpHours to 100AH. To list all stored values use AT+LIST command.

**NOTE:** Detailed explanation of each value is outside of scope of this section. Please refer to pages 6-9 for detailed explanation of each value.

- **AT+VR** – Voltage Range. Set to 0 for 64V range or 1 for 350V range.
- **AT+AH** – Pack AmpHours. Valid range 1 to 3000.
- **AT+FV** – Full Voltage. Valid ranges 0 – 640 ( 64V unit) or 0 – 350 ( 350V unit)
- **AT+MSOC** – Min SOC. Valid range 0 – 80.
- **AT+DIR** – Current sensor direction. Set to 0 for Reversed or 1 for Normal.
- **AT+TC** – Temperature Correction. Valid range 0 – 20.
- **AT+LF** – Low Fuel trigger level. Valid range 0 – 80.
- **AT+TU** – Temperature Units. Set to 0 for Celsius or 1 for Fahrenheit.
- **AT+CE** – Charge Efficiency. Valid range 50 – 100.
- **AT+DZ** – Dead Zone. Valid range 0 – 9.
- **AT+TM** – Test Mode. Set to 0 for OFF or 1 for ON.
- **AT+ST** – Sensor Type. Set to 1 for 1000A or 2 for 2000A
- **AT+CS** – Current Scale. Valid range -50 – 50.
- **AT+IL** – Idle Load. Valid range 0 – 20.
- **AT+BATID** – Battery ID. Valid range 1-9.
- **AT+CCNT** – Cell Count. Valid range 4-100.
- **AT+DTYPE** – Data Type. Set to 0 for fixed data length or to 1 for comma delimited format.
- **AT+LVC** – Enable or Disable LVC (Low Voltage Cutoff) 0 for Off 1 for On.
- **AT+SIP** – Source IP address. Example - AT+SIP=192.168.0.254
- **AT+SMASK** – Source Mask.
- **AT+SGW** – Source Gateway.
- **AT+DIP** – Destination IP address
- **AT+DPORT** – Destination port in decimal form. Example AT+DPORT=65261

- **NOTE:** Below commands don't have any values. These commands execute actions as described below.
- **AT+CALIB** – Zero point calibration (ensure no charge/discharge loads are present before executing)
- **AT+LIST** – Lists all stored values.
- **AT+RESET** – Resets IP parameters to factory defaults and creates a new MAC address where the last 4 digits are random.
- **AT+END** – End Setup mode and resume to normal Data mode.
- **AT+SETUP** – Halt normal operation and enter Setup mode.

**Data Mode commands:** During data mode SOC Gauge can receive and process real time commands listed below. Commands must start with "\$" and end with CR+LF termination.

- **\$STREAMOFF** – Turn off data stream.
- **\$STREAMON** – Turn on data stream.
- **\$POLL** – Poll data one time.
- **\$BATOFF** – Turn off battery power
- **\$BATON** – Turn on battery power.
- **\$CHARGEON** – If battery is over-discharged with open CL this command forces the contactor to latch ON to allow charging to begin. BMS expects voltage rise to qualify that it is being charged.

## **CANbus 2.0B:**

**Connection:** 2 wires are needed to interface to the CANbus data.

1	CanL (BLACK)	Isolated CanL signal
2	CanH (RED)	Isolated CanH signal

**CAN Bus Implementation:** Compatible with SAE J1939. The following messages have been defined for SOC Gauge. Bus speed is 250kbit/s. Messages are sent at 1 sec interval, 29bit addressing and 8 byte data frames are used (CAN 2.0B). CanH and CanL circuits are galvanic isolated from battery pack.

ID	Description	Byte 0	Byte 1	Byte 2	Byte 3	Byte 4	Byte 5	Byte 6	Byte 7
18FF98FA	Bat. State	BAT_ID	STATE						
18FF99FA	Bat. Voltage	BAT_ID	V_H	V_L	VF_H	VF_L	VE_H	VE_L	
18FF9AFA	Current	BAT_ID	DIR	CUR_H	CUR_L				
18FF9BFA	Power	BAT_ID	DIR	PWR_4	PWR_3	PWR_2	PWR_1		
18FF9CFA	Capacity	BAT_ID	SOC	FUEL	AH_H	AH_L	AHT_H	AHT_L	
18FF9DFA	Temperature	BAT_ID	TMP_INT	TMP_EXT					

**NOTES:** Suffixes \_H/\_L represent Hi and Low bytes of 2 byte values. Suffixes \_1/\_4 represent 4 byte values.

**BAT\_ID** – battery address, typically 1, in multi-battery systems this will identify different batteries on the same CAN bus.

**STATE** – State of the battery, represents one of basic conditions of a battery in real time. Status Byte is the last byte of parameter “R” in Serial/Ethernet streams. In CANBus stream it is the first byte in the message ID = 0x18FF98FA (Battery State).

Description of bits in the Status Byte:

Bit 7	Bit 6	Bit 5	Bit 4	Bit 3	Bit 2	Bit 1	Bit 0
-------	-------	-------	-------	-------	-------	-------	-------

**Bit 0 – Charge Allowed/Requested.** In a single contactor system this bit indicates Generator On/Off signal to request the charge when battery is less than full. In dual contactor system this indicates the state of Charge contactor.

**Bit 1 – Charge Detected.** Indicates that charge voltage was detected on the far side of the contactor, allowing contactor to close even when battery is in Low/Deep voltage state. This bit resets when battery reaches Nominal voltage.

**Bit 2 – NeverDie® Reserve State.** Indicates that battery is in the Reserve State.

**Bit 3 – Cell Loop is open.** Indicates that cell loop is open.

**Bit 4 – Low Voltage State.** Indicates that battery voltage is below LVC.

**Bit 5 – Deep Voltage State.** Indicates that battery voltage is below DVC.

**Bit 6 – Short Circuit Protection State.** Indicates that battery is recovering from short circuit event.

**Bit 7 – Power OFF State.** Indicates that battery was turned off by a command or a button press. 0 = inactive, 1 = active.

For example, when battery reaches LVC and turns off the contactor, Status Byte = 16 (Decimal). If the button is then pressed to enable Reserve, Status Byte will be 20 (Decimal).

**V, VF, VE** – Instant voltage, Full voltage, Empty voltage. Resolution 0.1V, range 0V – 6553.5V

**CUR** – Instant current. Resolution 0.1A, range 0A – 6553.5A

**DIR** – Current direction, 1 – charging, 0 - discharging

**PWR** – Watts instant. Resolution 1W, range 0W – 4MW

**SOC** – State of charge, percentage 0%-100%

**FUEL** – Fuel Gauge, percentage 0%-100%

**AH, AHT** – AmpHours remaining, AmpHours total. Resolution 0.1AH, range 0AH - 6553.5AH

**TMP\_INT, TMP\_EXT** – Temperature from internal and external (optional) sensors. Range -127C to 127C

Default values for battery system: VAh

<b>V Range</b>	<b>64V</b>
<b>PackSize</b>	<b>Ah</b>
<b>Full Vlt</b>	<b>v</b>
<b>Min SoC</b>	<b>20%</b>
<b>CurrDir</b>	<b>Normal</b>
<b>TempComp</b>	<b>10%</b>
<b>LowFuel</b>	<b>10%</b>
<b>TempUnit</b>	<b>F</b>
<b>ChargEff</b>	<b>96%</b>
<b>DeadZone</b>	<b>0.3</b>
<b>TestMode</b>	<b>Off</b>
<b>Out Mode</b>	<b>0</b>
<b>SensType</b>	<b>1000A</b>
<b>CurScale</b>	<b>0.0%</b>
<b>Cell Count</b>	
<b>LVC Enable</b>	
<b>IdleLoad</b>	<b>mA</b>
<b>Calib..?</b>	<b>No</b>