

TH6 Hybrid 6-Camera System



Installation and Setup Guide

— THIS PAGE INTENTIONALLY LEFT BLANK —

Contents

Section 1 — Installation pg. 5

[Installing the DVR](#)

[Installing the Signals Harness](#)

[Installing the Expansion Harness](#)

[Installing the SD Card](#)

[Hardware Installation Checklist](#)

[Firmware Updates](#)

[Copying DVR Configuration](#)

Section 2 — Operation pg. 17

[DVR Front Panel Features](#)

[DVR Back Panel Features](#)

[Video System Status](#)

[Tagging Video for Review](#)

[Accessing On-screen Display](#)

[Using On-screen Keyboards](#)

[Working with Video](#)

[Health Check](#)

Section 3 — Basic Configuration pg. 31

[Setting Up the DVR](#)

[Time/Date Menu](#)

[Title/Display Menu](#)

[Camera Settings](#)

[Signals](#)

[Alarms](#)

Section 4 — Advanced Configuration pg. 45

[Recording Settings](#)

[Network Settings](#)

[Advanced Network Settings](#)

[VMS Servers](#)

[G Sensor](#)

[Speed Settings](#)

[GPS Fencing](#)

[User Levels](#)

[System Settings](#)

[Program Update](#)

[Monitor Settings](#)

[Wake on Input, Digital Output](#)

Introduction

This Guide provides the following information for Installers, System Technicians, and Vehicle Operators working with the TH6 DVR system:

Installers

Explore the TH6 DVR system components, physical and electrical installation, and system-level settings, including camera and DVR configuration. You'll also learn to test system functionality and interoperability with other equipment, how to clone DVR configuration, and performing firmware updates.

NOTE: Professional Installation



DVR systems must be installed by a professional installer with the appropriate experience and equipment.

System Technicians

Help troubleshoot and maintain the mobile surveillance system using a monitor plugged into the DVR front panel, remove and replace hard drives, access video, and set up cameras and recording options.

Note: on-screen configuration and video playback requires a portable video monitor and a USB mouse.

Vehicle Operators

Learn how to flag an event so incident video can be easily located, and understand the system status indicator, so you'll know when the DVR is recording.

Installation

- Installing the DVR..... 6
 - Tools and Equipment6
 - Physical Location.....6
 - Installation Requirements7
 - Physical Installation7

- Installing the Signals Harness 9

- Installing the Expansion Harness (*optional*) 10

- Installing the SD Card (*optional*)11

- Hardware Installation Checklist 12

- Firmware Updates..... 13
 - Firmware Version.....13
 - To install a firmware update:.....13

- Copying DVR Configuration 14
 - Copying DVR Settings14
 - Applying DVR Settings15

Installing the DVR

Tools and Equipment

The DVR system must be installed by a professional installer. A professional installer has the experience and equipment to install and configure this DVR system to run properly.

Check that you have all the system components and inspect the units for any scratches or damage before installing.

Keys included in package contents:

- DVR keys for securing the removable hard drive
- Front cover keys for securing the removable front cover

Configuration equipment:

For on-screen configuration: portable video monitor and mouse

- For vMax Web configuration: laptop and an Ethernet cable

Physical Location

The DVR is secured with a security front cover and a cable cover. The cable cover allows wiring to enter from the underside of the back of the unit.

The DVR is designed for horizontal installation, on top of the mounting plate (see the diagram on page 8), but may be installed vertically if required. **Do NOT install the DVR upside down.**

WARNING: Risk of Heat or Moisture Damage



Do not install the DVR in a location where the unit is exposed to excessive heat or moisture.

Installation close to extreme heat or moisture voids the product warranty.

Route wiring and cables away from sharp edges that might damage the insulation. Avoid sharp bends in the cable.

Contact Technical Support before attaching the DVR to other equipment in the vehicle.

Before installing the DVR, keep in mind that a well-ventilated location and sufficient clearance around the unit are key factors for performance and maintainability. The following table provides information on installation requirements.

Installation Requirements

WARNING: Safety and Electrical Systems



It is your responsibility to avoid damaging safety or electrical systems.

| | |
|--------------------------------------|---|
| Ventilated Location | Install the DVR away from any sort of heat outlet, heater, or AC blower. Do not operate the DVR in a closed-in area or restrict ventilation in any way. The DVR requires air circulation to maintain optimum operation temperature and provide best performance. Do not expose the DVR to moisture. |
| Mount to secure surfaces only | Do not mount the DVR to a plastic panel or other surface that is subject to constant vibration. |
| Mounting orientation | We strongly recommend mounting the DVR in a horizontal orientation (on top of the mounting tray); however, to accommodate space restrictions, vertical mounting is acceptable. Do NOT install the DVR upside-down. |
| Clearance around the DVR | Allow sufficient clearance of at least six (6) inches in front of the DVR and two (2) inches to each side for removal of the security front cover and easy access to the hard drive and USB ports. Allow sufficient clearance behind the DVR for camera cables, mounting cables, Ethernet cables, and power cables. |
| Mounting cables | The radius for the mounting cables will be dictated by the cable cover. The rearmost surface of the cable cover will be about 3 inches from the back of the DVR to allow camera cables to bend over each other. |
| Ethernet cables | Avoid right angle bends in the Ethernet cables. |
| Power cables | Provide enough slack on the power cable to prevent any force from being exerted on the connectors. A single 4-inch diameter loop is sufficient. |

Physical Installation

The DVR typically ships with the locking front cover, mounting plate, and cable cover off, but in the shipping box. The hard disk drive is in a separate box in the system shipping kit.

To install the DVR:

1. Select an appropriate mounting location and orientation (horizontal or vertical).
2. Insert a hard drive in the DVR.
3. Insert the key into the hard drive lock and rotate a quarter turn to lock the drive.

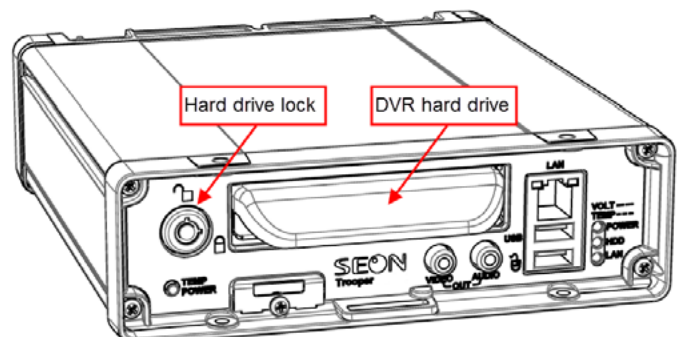

4. Use the mounting plate to mark the desired position of the DVR and drill the four mounting holes.
5. Fasten the mounting plate to the mounting surface with the four self-drilling screws.
6. Slide the rear bottom edge of the DVR into the spring tab on the back edge of the mounting tray.
7. Attach the front bottom edge to the front of the DVR using the two pan-head Phillips screws.
8. Connect the necessary cables and components. For more information, see "DVR Front Panel Features" on page 18 and "DVR Back Panel Features" on page 19.
9. Attach the cable cover to the DVR using the thumb screws provided.
10. When DVR installation is complete, attach the front door by hooking the door along the top edge and turning the key to the locked position.

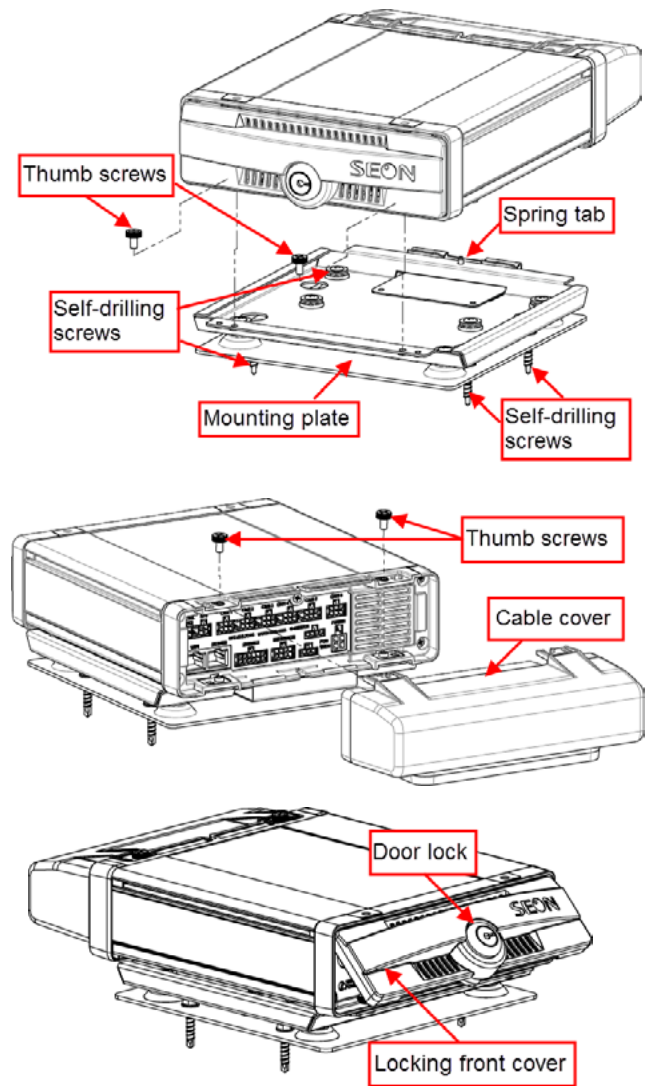

Installing the Signals Harness

About

This topic describes installing the Signals Harness, which connects the DVR to Signal inputs, and to the optional Event/Diagnostic button and Wake on Input trigger: for more information on each of these features see:

- "Signals" on page 41
- "Tagging Video for Review" on page 22
- "Wake on Input, Digital Output" on page 68

Before you begin...

It is your responsibility to avoid damaging safety or electrical systems.

Ensure you read and understand "Installation Requirements" on page 7.

To install the Signals Harness

Connect the 2x6 Microfit to the SIGNALS socket on the DVR.

- Connect the 5 signal input wires, as shown in the in the Installation Diagram in the [TH6 Quick Install Guide](#) on the inView Guardian product page.
- Connect the 1x5 Microfit to the Adapter harness for the Event/Diagnostic button (*optional*).
- Remove the 1x3 Microfit and connect the green and black wires to a Wake on Input trigger (*optional*) as shown in the Installation Diagram in the [TH6 Quick Install Guide](#) on the inView Guardian product page.

The Signals harness is **Part # WT1**.

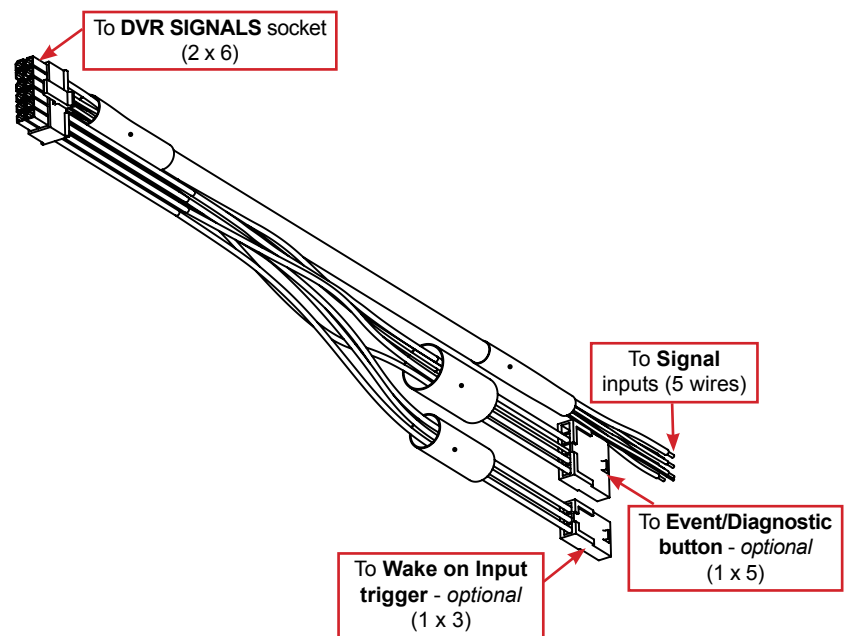

Installing the Expansion Harness (*optional*)

About

This topic describes installing the optional Expansion Harness, which can connect the DVR to Student Tracking and Rear Vision systems, and provides a digital output to trigger other devices when an Alarm is detected (for more information, see "Alarms" on page 43).

Before you begin...

It is your responsibility to avoid damaging safety or electrical systems.

Ensure you read and understand "Installation Requirements" on page 7.

To install the Expansion Harness

Connect the 2x4 Microfit connector to the EXPANSION socket on the DVR.

- Connect the 4-pin to the Student Tracking harness (*optional*).
- Connect the 2-pin to the Rear Vision System harness (*optional*).
- Connect the Digital Out black and blue wires (*optional*) as shown in the Installation Diagram in the [TH6 Quick Install Guide](#) on the inView Guardian product page.

The Expansion Harness is **Part #060-1059**

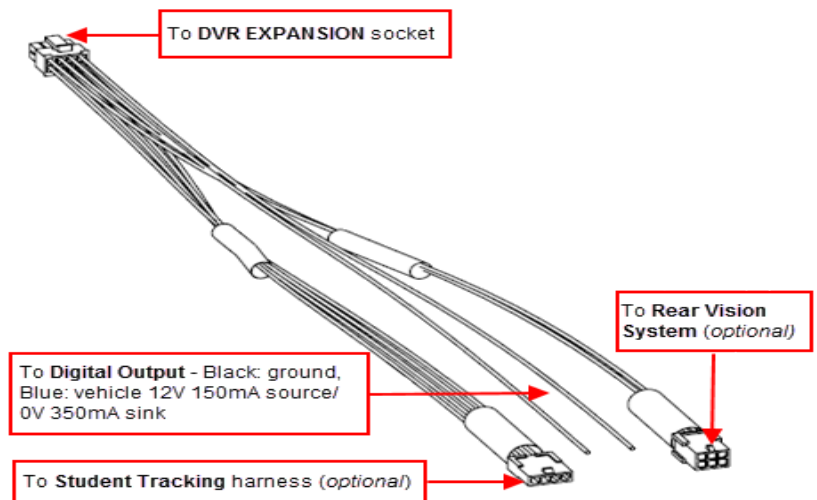

Installing the SD Card (optional)

About

This topic describes installing the optional SD card, a secondary storage device used to record the DVR's low resolution (and low frame rate) stream, providing backup storage to the SD card. The amount of backup storage available from the card is determined by the card's capacity.

TIP: Repeat Record setting controls SD card "looping"



The **Configuration** → **Record** → **Repeat Record** setting determines what happens when the SD card becomes full. The default is to loop (record over the oldest video).

For more information, see "Recording Settings" on page 46.

Only the lower resolution "Record 2" video stream is stored on the SD card. Access to the recording on the SD card is only possible through vMax View, since the card is intended for backup purposes.

To install the SD card:

1. On the front of the DVR, remove the screw holding the SD card cover plate, and remove the plate.
2. Remove the adhesive plastic shipping strip covering the SD card slot.
3. Insert a Seon-approved SD card into the slot until it clicks.
4. Replace the SD card slot cover plate.

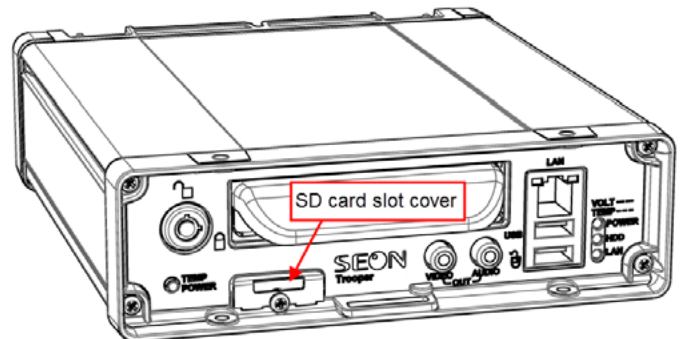

Hardware Installation Checklist

| | |
|---|--|
| √ | Harnesses (camera, recorder, and accessories) |
| | Ensure cables and harnesses are properly secured. |
| | Check that sharp metal edges are not touching cables or harnesses. |
| | Ensure connections are solid (no shorts). |

| | |
|---|--|
| √ | Cameras |
| | Ensure tight mounting. |
| | Examine the internal harness connections and ensure they are solid. |
| | Ensure the lid is properly seated on the gasket and secured tightly. |
| | Check camera(s) field of view. |

| | |
|---|---------------------------------------|
| √ | DVR |
| | Ensure tight mounting. |
| | Check that all connections are tight. |

| | |
|---|---|
| √ | System |
| | Install fuses. |
| | Plug portable video monitor into DVR, and power up the DVR from the vehicle ignition. |
| | Configure the DVR to required specifications locally using the mouse and monitor, or remotely by accessing vMax Web via WiFi or Ethernet using a PC. For more information, see "Basic Configuration" on page 31 |
| | Confirm the LAN, HDD, and PWR status indicators on the DVR front panel work properly. |
| | Confirm that all cameras and audio sources operate properly. |
| | Test audio/video record and playback. |
| | Reformat the hard drives by navigating to Main Menu → Configuration → System → Program Update → Format . A warning message tells you all data will be erased. Click Yes . When the process completes and a message appears, click OK . Exit the Configuration setting menu, and system setup is complete. |
| | Fasten and lock the front cover. Secure the cable cover on the DVR using the screws provided. |

Firmware Updates

About

This topic describes how to install a DVR firmware update. Firmware controls how DVR features operate, including the Playback and Configuration menu displays. Technical Support may direct you to install a firmware update when new features are added or specific issues are addressed.

Before you begin...

Contact Technical Support to obtain the latest firmware update for your DVR. Copy the update file to a USB storage device formatted by a Windows-based computer using the FAT file format.

Firmware Version

The current firmware version appears in the top-right corner of every Configuration menu.

For instructions on opening the Configuration menus, see "Accessing the On-screen Display" on page 23.



IMPORTANT: Firmware Updates 

Only install firmware updates as directed by Technical Support

To install a firmware update:

1. Power-up the DVR using the vehicle ignition.
2. Insert the USB memory device with the new firmware version into the USB port on the DVR.
3. After the DVR starts up, right-click in the On-screen Display and select **Configuration → System Program Update**.
4. In the Program Update tab, click **Update**. A confirmation window appears.
5. Click **Yes** to proceed or **No** to cancel. **Yes** starts the firmware update, and a progress bar displays the percentage complete.
6. Once the update is finished, the DVR automatically restarts.
7. Remove the USB memory device.

WARNING:  Do not crank the vehicle power or remove power while updating the DVR firmware. Equipment damage may result.

NOTE: After restarting, the DVR may take up to 3 minutes to load and complete the upgrade. **Wait until the DVR finishes loading.**

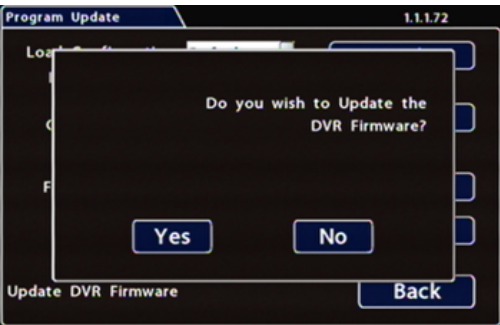

Copying DVR Configuration

About

This topic explains how to copy setup details from a DVR and apply them to other DVRs. This capability saves a lot of time and effort, and ensures consistent configuration when installing and maintaining DVRs in a fleet.

Before you begin...

Ensure the DVR you're copying configuration from is set up properly. For more information, see "Setting up the DVR" on page 32.

This procedure requires physical access to the DVR you want to copy settings from, a portable video monitor, a USB mouse, and a USB storage device formatted by a Windows computer using the FAT. You should have a general understanding of mobile surveillance system components, and experience with Windows-based computers and storage media.

What are Configuration Files?

A configuration file preserves a particular DVR setup, so you can apply the settings to other DVRs in a single operation. You create a named configuration file, which contains all a DVR's current Configuration menu settings. If you need more than one system setup for your fleet (for example, a specific number of cameras and viewpoints for different vehicle configurations), build a separate configuration file for each situation.

You can load a configuration file onto DVRs during installation or when changes are required, and all settings are applied automatically.

Copying DVR Settings

Before copying configuration, ensure the DVR is set up for specific vehicle type and mobile surveillance requirements, including camera names/channels, recording parameters, Alarm and Signal assignments, system preferences, and networking details. For more information, see "Setting up the DVR" on page 32.

This procedure requires physical access to the DVR you want to copy settings from, a portable video monitor, a USB mouse, and a USB storage device formatted by a Windows computer using the FAT.

To create a configuration file:

1. Insert the USB storage device in the USB port on the DVR's front panel. For more information, see "DVR Front Panel Features" on page 18.
2. Access the OSD (On-Screen Display). For details, see "Accessing the On-screen Display" on page 23.
3. Right-click anywhere in the OSD view to access the **Main Menu**.
4. Select **Configuration** → **System** → **Program Update**.
5. In the **Store Current Configuration to:** pull-down menu, select **USB Device**.
6. Click the **File Name** field and use the on-screen keyboard to change the configuration file name (maximum 4 characters).
Best practice is to choose a name that references the fleet and/or configuration type (e.g. "SB5C" for a school bus with 5 cameras).
7. Click **Store**.
In the confirmation that appears, click **Yes**.
8. Click **OK**.
The configuration file is created on the USB device.



Applying DVR Settings

For new DVR installations, apply predefined settings from a configuration file on a USB memory stick.

Once a DVR is set up, you can also upload a new configuration file by connecting to the DVR over a network, or via the Commander application if the DVR is equipped with wireless capabilities. Commander can also perform batch updates on multiple DVRs. For more information, please see the [Commander User Guide](#) (Safe Fleet Community Document Library → SW User Guides → vMax Commander).

IMPORTANT: DVR Configuration Updates



Do not edit or copy DVR configuration locally when making updates over a network.

To copy configuration to a DVR from a USB storage device:

1. Power up the DVR using the vehicle ignition.
2. Connect the portable video monitor and USB mouse.
3. Insert a USB storage device containing a configuration file into the USB port on the DVR.
4. From the On-Screen Display, right-click anywhere in Live view to display the **Main Menu**.
5. Select **Configuration** → **System** → **Program Update**.
6. Use the **Load Configuration** menu to select the desired file.
Note: only the 10 most recent configuration files in the root folder of the USB drive are available from the drop-down menu.
7. From the **Include Network** pull-down menu, select whether or not to overwrite DVR network settings:
 - **No** keeps existing DVR network settings
 - **Yes** overwrites DVR network settings with configuration from the file.
8. Click **Load**, then select **Yes** in the confirmation dialog to proceed.
9. Click **Back** in the **Program Update** and **System Settings** tabs to return to the Configuration Menu.
10. Remove the USB memory device.
11. Confirm that the new configuration settings have been applied.

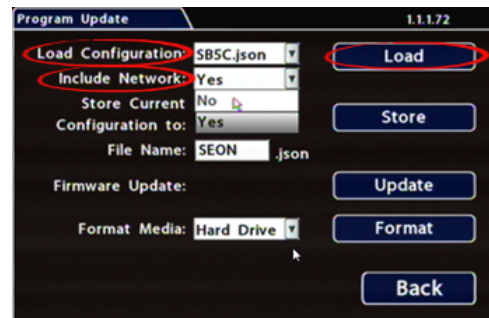

IMPORTANT: Time/Date and Vehicle-specific Configuration



Open the Configuration menu and verify all Time/Date settings.

Also be sure to update vehicle-specific configuration, including:

- **Title/Display** → **Main Title** - generally contains the bus #/vehicle ID where the DVR is installed
- **Network** configuration (if the DVR is equipped with wireless capabilities)
- **Alarm/Signal** → **G Sensor** calibration (if the external G-Sensor is installed)

For more information, see "Setting up the DVR" on page 32.

Operation

- DVR Front Panel Features 18
- DVR Back Panel Features..... 19
- Video System Status..... 20
 - Event/Diagnostic Button20
- Tagging Video for Review 22
- Accessing the On-screen Display 23
 - Video Configuration, Playback, and Archiving23
 - Using the On-screen Display23
 - Live View23
 - On-Screen Display Fields24
- Using On-screen Keyboards 25
 - Entering Data.....25
- Working with Video 26
 - Playing Back and Copying Video.....26
 - Playback Toolbar Icons27
 - Searching Video28
- Health Check..... 29
 - Information Display29

DVR Front Panel Features



1. DVR Drive lock - requires the DVR drive key to unlock and remove the DVR drive.
2. DVR Drive - for playback, remove the drive and use the HDD Dock connected to a PC.
3. LAN Port - RJ-45 Ethernet connector for a laptop, Smart-Reach Mobile wireless equipment, or other accessories
4. Status Lights:
 - TEMP - flashes quickly when the DVR cannot power up due to temperature limitations
 - VOLT - flashes slowly when the DVR cannot power up due to voltage limitations
 - POWER - illuminates when the DVR is powered on
 - HDD - illuminates when the DVR is accessing the drive
 - LAN - illuminates when there is network activity on the Local Area Network connection
5. Mouse Port - connection for USB mouse
6. USB Port - supports USB devices used to:
 - copy video and audio information
 - export video clips
 - update DVR firmware
 - import/export configuration data and archives
7. AUDIO - RCA jack for audio output
8. VIDEO - RCA jack for video output (playback and live viewing with a portable monitor)
9. SD Card Slot Cover - SD card for recording low resolution ("R2") backup video stream
10. TEMP POWER
 - powers on the DVR for five minutes if held for more than 5 seconds
 - powers down the DVR if held for more than 5 seconds in temporary power mode or in shutdown sequence with ignition off

DVR Back Panel Features

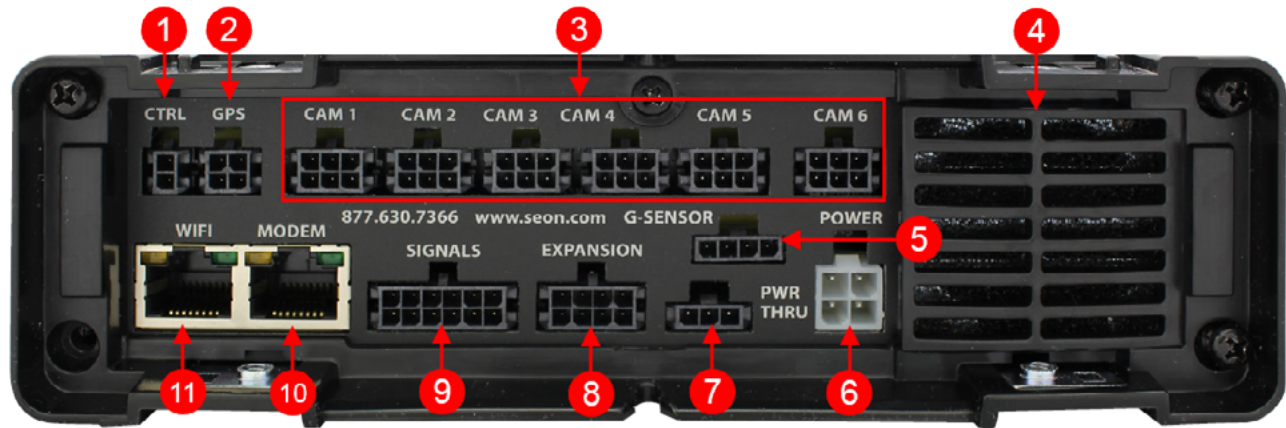

1. CTRL - control connector for accessories
2. GPS - input connector for GPS receiver
3. CAM 1 to CAM 6 - input connectors (6-pin) for six cameras
4. Fan - outflow fan
5. G-SENSOR - input for optional G-force sensor unit
6. POWER - input for power harness
7. PWR THRU - output connector for passing power to other devices
8. EXPANSION - connector for communicating with other devices
9. SIGNALS - connector for signal harness, with an optional adapter for the alarm button/diagnostic indicator
10. MODEM - RJ-45 Ethernet LAN connector for a laptop, Smart-Reach Mobile wireless equipment, or other accessories
11. WIFI - dedicated Ethernet port for connectivity with Smart-Reach Lite wireless bridge and other equipment.

TIP: POE WIFI Port is 12-volt



In addition to the data transmitted, the POE (Power Over Ethernet) WIFI port supplies 12 volts to power accessories such as the Smart-Reach Lite wireless bridge.

Video System Status

About

This topic describes optional system status indicators, which tell you if the system is recording, and whether an Alarm is triggered. Colored lights provide status details.

Before you begin...

An **Event/Diagnostic button (A)** or an **RGY Indicator (B)** must be installed in the vehicle. For more information, contact Technical Support.

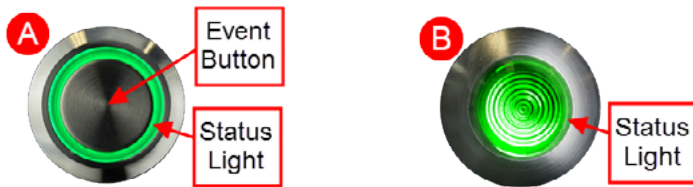

For information about using the Event Button, see "Installation" on page 5.

Event/Diagnostic Button

Basic System Status *(for Operators)*

TIP: Report a continually flashing green status light to a supervisor



- When the vehicle ignition is turned on, the status light flashes green for a short period, then turns solid green.
- **A solid green status light indicates the video system is operating normally.**
- **Flashing green for more than a couple of minutes indicates the system requires attention** (see the next section for details).

Status Details (for Installers and Technicians)

If the DVR is not recording, the status light display depends on the installed firmware, as described below. The current firmware version appears in the top-right corner of every Configuration menu (for more information, see "Firmware Updates" on page 13).

| Potential Causes (DVR not recording) | Status light: Firmware - v1.3.1.x or older | Status light: Firmware - v1.3.2.x or newer |
|---|--|--|
| HDD unlocked | Blinking | Blinking |
| HDD fault (missing, bad drive) | Blinking | Blinking |
| DVR overheated (stopped recording) | Blinking | Blinking |
| DVR overheated (shutdown) | OFF | OFF |
| DVR warming up (low ambient temperature) | OFF | OFF |
| DVR booting up | Blinking | Blinking, then ON |
| DVR in local Playback menu, TEMP power mode, or Power Off Delay | Blinking | ON |
| DVR in firmware upgrade | Blinking | ON |

RGY Indicator

On vehicles equipped with an RGY Indicator (**B**), colored lights provide status details:

TIP: Report a flashing green, yellow, or red RGY status light to a supervisor 

The RGY status light should turn solid green approximately two minutes after the vehicle ignition is on.

| Light | Status |
|----------------|--|
| Off | Powered down |
| Red | On (not recording) |
| Solid green | On (recording) |
| Flashing green | On (recording, and alarm is triggered) |
| Yellow | On (recording, but there is video loss from one or more cameras) |



Tagging Video for Review

About

This topic explains how to flag an event, so the video footage can be located easily at a later time.

Before you begin...

In order for an operator to tag video, an Event/Diagnostic Button or Alarm Button must be installed in the vehicle. For more information, contact Technical Support.

TIP: Automatic alarm triggers



Alarms can also tag video automatically when applied to a G Sensor threshold, excessive speed, or a GPS fence. For more information, see "Alarms" on page 43.

To tag an event so the video is available later:

TIP: DVR is always recording!



Under normal conditions, the DVR is continuously recording when the vehicle ignition is on.

If something happens that should be flagged for review, press the Event Button to ensure the event is easy-to-find later.



Each time you flag an event with the Event Button, the system places a special Alarm tag on the video, as well as the date and time. Upon playback, any triggered Alarms are displayed, and the reviewer can jump directly to the tagged sections and see the associated video (details depend on how the DVR is configured).

For more information on accessing and viewing recorded video, see the [View User Guide](#) (Safe Fleet Community Document Library → SW User Guides → vMax View).

If your organization uses Commander, tagged video can be automatically downloaded and made available to reviewers when your vehicle returns to the depot. For more information, see the [Commander User Guide](#) (Safe Fleet Community Document Library → SW User Guides → vMax Commander).

Accessing the On-screen Display

About

This topic explains how to connect a local monitor to the DVR to access configuration menus, view live camera feeds, or search, play back, and archive video.

Video Configuration, Playback, and Archiving

Installers and System Technicians can access DVR configuration, playback and archiving features locally from the DVR, via the On-screen Display (OSD) and a portable video monitor. For full-featured video review, searching, and archiving, we recommend vMax View video management software on a Windows-based computer. For more information, see the [View User Guide](#) (Safe Fleet Community Document Library → SW User Guides → vMax View).

Using the On-screen Display

1. Connect a portable video monitor to VIDEO OUT on the DVR front panel.
2. Plug a USB mouse in a USB socket on the front of the DVR.
3. Power up the DVR.
The DVR splash screen appears briefly; the system displays live camera feeds, as described below in **Live View**.
4. Right-click anywhere in the OSD screen to view the **Main Menu**:
 - **Configuration** - access DVR menus to set up the system. For more information, see "Setting up the DVR" on page 32.
 - **Playback** - search, play back, and archive video directly from the DVR. For more information, see "Working with Video" on page 26.

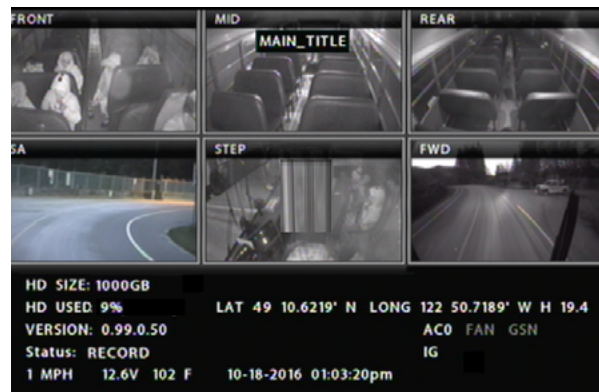
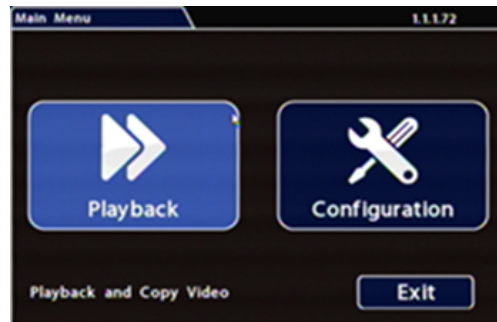
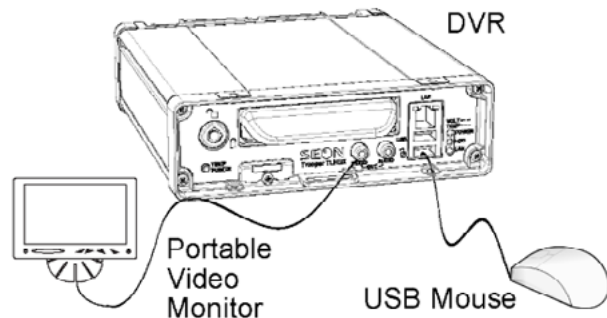

Live View

During live viewing and recording, in addition to active camera feeds, the information displayed on the OSD includes the items shown in the image and the following table (for how to configure camera titles, see "Camera Settings" on page 39):

On-Screen Display Fields

| Feature | Description |
|------------------|--|
| [MAIN_TITLE] | Main title of the DVR; max. 32 characters. |
| [CAMERA_TITLE] | Appears in the top-left corner of each viewing section (in the example, "FRONT", "MID"...). |
| HD SIZE | Formatted size of the DVR internal drive, in gigabytes (GB). The second value in square brackets is the size of the SD card. "OFF" indicates the storage media is not present. |
| HD USED | Percentage of recorded video on the DVR hard drive. The second value in square brackets indicates the percentage of recorded video on the SD card. "OFF" indicates the storage media is not present. At 100%, the message displayed depends on the Repeat Record settings in the Recording Settings menu. |
| VERSION | DVR firmware version. |
| Status | DVR operational status: <ul style="list-style-type: none"> - LIVE (live mode - not recording) - PLAYBACK (DVR playing locally) - RECORD (normal recording) - ALARM (alarm recording) - V.LOSS (video loss or camera signal loss) |
| Speed Display | Vehicle speed in MPH or KPH. |
| Voltage | System voltage from 8 to 32 VDC. |
| Temperature | DVR temperature in degrees Fahrenheit or Celsius. |
| Time and Date | Current/recorded time and date |
| GPS Coordinates | If GPS is connected, the actual coordinates (latitude, longitude, and heading) appear. If GPS is connected but the satellite signal is not being received, zeros are displayed. |
| AC (Alarm Count) | Number of alarms triggered Resets to 0 when DVR is restarted. |
| FAN | Highlights to indicate trouble with the DVR fan. |
| GSN | Highlights when external G-Sensor is connected. |
| IG | Highlights when vehicle ignition is on. |

Using On-screen Keyboards

About

This topic describes entering text and numbers in OSD (On-screen Display) fields when accessing the DVR locally with a mouse and monitor.

Before you begin...

A portable video monitor and a USB mouse must be connected to the DVR.

For more information, see "Accessing the On-screen Display" on page 23.

Entering Data

To enter text and numbers in OSD fields using a mouse:

1. Click in an OSD field that accepts text or numbers as input.
The on-screen keyboard (text or numeric, as shown below) pops up on the screen.
2. Click text or numbers to enter values, and use the virtual keys as required.
Cancel closes the keyboard without saving changes.
3. When you're done, click **Enter** to save changes and close the keyboard.

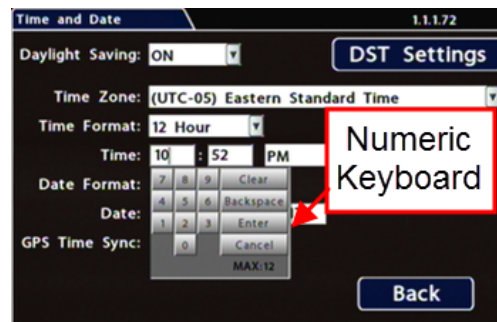
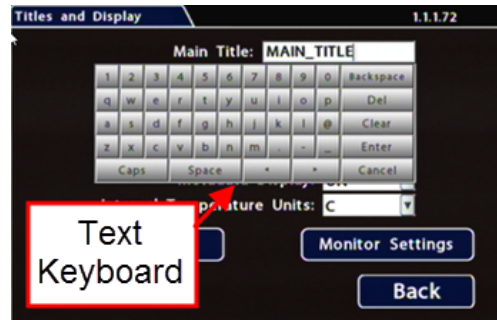

Working with Video

About

This tutorial explains how to use the Playback menu to search, play back, and copy video directly from the DVR hard drive.

These procedures are intended for installers and system technicians to test and confirm mobile surveillance system functionality. For full-featured video playback, search, and archiving, we recommend the vMax View application on a Windows-based computer. For more information, please see the [View User Guide](#) (Safe Fleet Community Document Library → SW User Guides → vMax View).

Playing Back and Copying Video

To search, play back, and archive video from the OSD (On-Screen Display) menus:

1. Connect a portable monitor and USB mouse, and power up the DVR. For more information, see "Accessing the On-screen Display" on page 23.
2. Right-click anywhere in the OSD view to access the **Main Menu** tab.
3. Click **Playback**.
4. In the center of the playback view, click the **Show/Hide** icon:



The **Playback Toolbar** appears.

5. Click icons to browse video and archive clips. For icon descriptions, please see "Playback Toolbar Icons" in the next section.

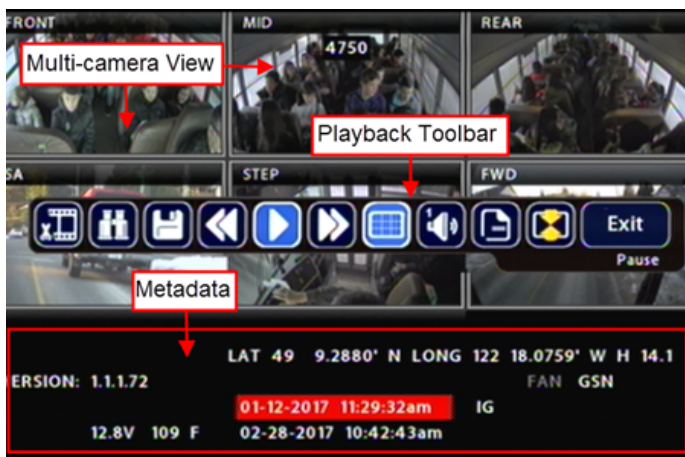
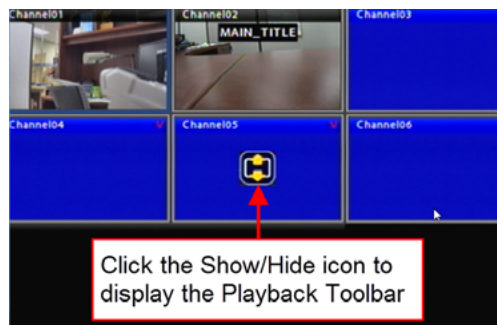
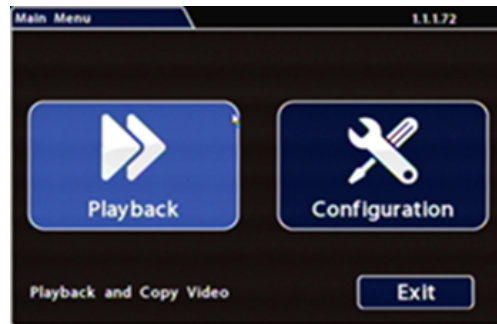

Playback Toolbar Icons

To display the Playback Toolbar, follow steps 1 through 4 in the previous section.

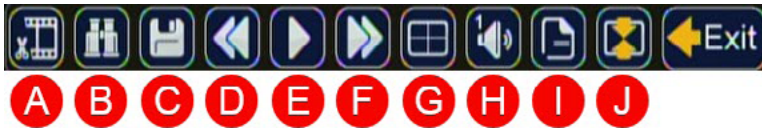

| | Icon Name | Function |
|----------|------------------------------------|---|
| A | Start of clip/End of clip | Sets the start of clip and the end of clip points for archiving. |
| B | Search | Searches by Date, Time, Alarm, Signals, or System Event. |
| C | Archive | Displays the Archive window to save a video clip to USB memory device. |
| D | Fast Rewind | Reverses playback. With playback paused, each click reverses the video by one frame. |
| E | Play/Pause | Starts/pauses playback. |
| F | Fast Forward | Fast forwards playback. With playback paused, each click advances the video by one frame. |
| G | Individual Camera/Multi-view | Displays camera 1, 2, 3, 4, 5, 6, or multi-view. |
| H | Audio | Cycles through Audio for channel 1, 2, 3, 4, 5, or 6. |
| I | Metadata Text Overlay | Turns on text overlay: temperature, system voltage, GPS data (if recorded), speed, date, and time. For more information, see "Metadata Details" on page 38. |
| J | Show/Hide Playback Tool Bar | Shows/hides the playback tool bar. |
| | Exit | Closes the On-Screen Display. |

Searching Video

The DVR includes a simple, powerful search feature that quickly finds recorded information by Date and Time, Alarm, Signals, or System Events.

To view the Search menu:

- From the **Playback Toolbar**, click the Search icon:
The **Search** tab appears (options displayed depend on the **Search Only** pull-down



menu selection).

- Use the **Start/End Date** and **Time** fields to set the desired period to search.

For instructions on how to enter numbers into the Date and Time fields, see "Using On-screen Keyboards" on page 25.

- If desired, use the **Search Only** pull-down and sub-menus to specify **Alarms**, **Signals**, or **System Events** to search.
- Click **Search**.
 - If **Search Only** is set to **Time**: Playback starts from the specified time and date (if the video exists on the hard drive).
 - If you selected **Alarms**, **Signals**, or **System Events**:

The DVR retrieves a list of recorded video segments containing the specified event type. Select an item from the list, then click **Play** to view the video captured when the event occurred.

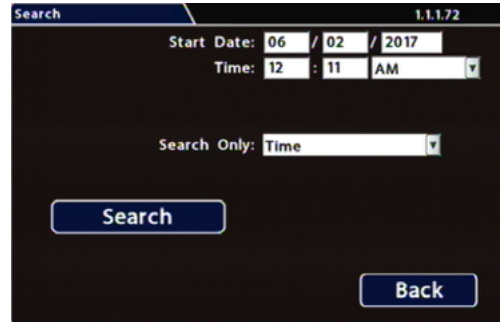

| Event No. | Start Date/Time | Event Type |
|-----------|-----------------------|------------|
| 1 | 01-12-2017 11:50:33am | S1 |
| 2 | 01-12-2017 11:42:21am | S1 |
| 3 | 01-12-2017 11:37:42am | S1 |
| 4 | 01-12-2017 11:37:07am | S1 |
| 5 | 01-12-2017 11:34:02am | S1 |
| 6 | 01-12-2017 11:29:10am | S1 |
| 7 | 01-12-2017 11:26:31am | S1 |
| 8 | 01-12-2017 11:19:39am | S1 |
| 9 | 01-12-2017 11:13:07am | S1 |
| 10 | 01-12-2017 11:09:32am | S1 |

Prev Pg Next Pg 0001/0084 Play Exit

Health Check

About

This topic describes the Health Check tab. It provides information on hard drive temperature, hard drive operational hours, Ethernet connections, and general DVR health.

Before you begin...

Power up the DVR with a monitor and USB mouse connected, then right-click in Live view and select **Configuration**.

For more information, see "Accessing the On-screen Display" on page 23.

To display Health Check information:

Select **Title/Display** → **Health Check**.

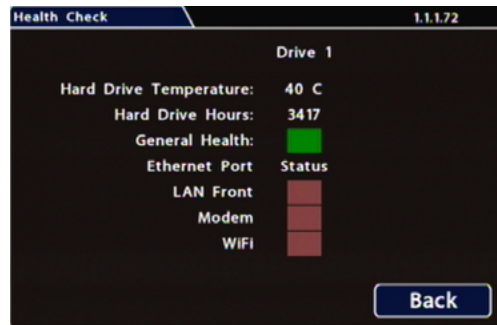

Information Display

| Menu Item | Description |
|------------------------|--|
| Hard Drive Temperature | Current temperature inside the drive. To choose whether this value displays in Fahrenheit (USA) or Celsius (Canada), use the Titles and Display → Internal Temperature Units setting. |
| Hard Drive Hours | The number of hours the drive has been powered on since it was manufactured. |
| General Health | Result of the drive subsystem self-check: green indicates normal operating status, while red means a drive failure was detected. |
| LAN Front | Connectivity indicator: green when a cable is connected from the DVR's front LAN port to an operational network device; otherwise red. |
| Modem | Connectivity indicator: green when a cable is connected from the DVR's rear Modem port to an operational network device; otherwise red. |
| WiFi | Connectivity indicator: green when a cable is connected from the DVR's rear WiFi port to an operational network device; otherwise red. |

— THIS PAGE INTENTIONALLY LEFT BLANK —

Basic Configuration

- Setting up the DVR..... 32**
 - DVR Menu Access..... 32
 - Basic DVR Configuration 33
- Time/Date Menu 34**
 - Time/Date Tab..... 34
 - Time and Date Menu Options 35
- Title/Display Menu 36**
 - Titles and Display Tab..... 36
 - Title/Display Menu Options 37
 - Metadata Details 38
- Camera Settings 39**
 - Camera Tab 39
 - Camera Settings - Menu Options 40
- Signals..... 41**
 - Signals Tab 41
 - Signals Tab - Menu Options..... 42
- Alarms 43**
 - Alarm Settings 43
 - Alarm Settings - Menu Options..... 44

Setting up the DVR

About

This topic describes procedures for configuring the DVR, including system settings, cameras/recording, alarms, and network details (if applicable).

Before you begin...

The unit should be installed, including power and cabling.

For more information, see "Installation" on page 5 .

DVR Menu Access

You can configure the DVR with its local on-screen menus using a monitor and mouse, or through a Web browser on a connected laptop. These settings can also be accessed remotely over a wireless network.

Local access with On-screen Display (OSD) menus:

Connect a portable monitor to the VIDEO OUT RCA jack on the DVR front panel and plug a mouse into the USB port to work with configuration settings.

For more information, see "Accessing the On-screen Display" on page 23.

To set or change a password, right-click in Live view, then choose the **Configuration** → **System Password** options.

Local access with vMax Web menus:

Configure the network connection on a PC, and connect to the DVR with an RJ-45 Ethernet cable. You can then use vMax Web to configure the DVR via Internet Explorer.

The default network settings only allow connecting the DVR to a laptop using an Ethernet cable.

For remote network access, consult your IT staff or Technical Support to configure the DVR to be on the same subnet as the laptop.

Remote access with vMax Web menus:

If you have Smart Reach wireless access, you can also access the DVR remotely using vMax Web via Internet Explorer. Contact the Technical Support team for more information.

Basic DVR Configuration

The DVR menu defaults cover most operational settings, but some basic customer and region-specific settings need to be configured for the DVR to operate optimally:

| Menu Names | Required Settings | For more information: |
|----------------------------------|---|-----------------------|
| Time and Date, DST Settings | Select display formats. Enter the current time and date, including Daylight Saving if applicable. Select the Time Zone. If GPS is installed, set GPS Time Sync ON to detect time and vehicle location. | See page 34 |
| Titles/Display | Enter the vehicle number in Main Title , and choose the information that displays as text when video appears. | See page 36 |
| Title/Display → Monitor Settings | If a Rear Vision Camera is installed, select monitor output settings. | See page 66 |
| Record | Set the Record Delay Off to 15-20 minutes for post trip check. If Wi-Fi is used, set the Power Delay Off to 2 hours for archive download. | See page 46 |
| Record → Camera | Turn off any unused camera channels, to avoid VLOSS events. | See page 39 |
| Alarms and Signals → Alarms | Configure each alarm depending on source (Signals, Speed, G Sensor, GPS Fence, Wake). | See page 43 |
| Alarms and Signals → Signals | Configure which signals will trigger alarms. Excessive speed and G Sensor readings can be set as signal outputs. | See page 41 |
| Alarms and Signals → Speed | If the DVR is used in Canadian fleets, select KPH speed units. | See page 57 |
| Alarms and Signals → G Sensor | If a G Sensor is installed, Calibrate. | See page 54 |
| Network | If Wi-Fi network is used, set addresses as instructed by a network administrator. | See page 48 |
| System | Select the audio channel to output from the DVR audio RCA socket. If a Diagnostic Indicator or RGY Illuminator is installed, select it here. | See page 62 |
| System → Program Update | Upload DVR configuration if necessary. Format the hard drive after all settings have been made. | See page 64 |

Time/Date Menu

About

This topic describes the Time and Date configuration tab settings, including time zone, daylight savings (if required), and optionally synchronizing the DVR date and time with GPS satellites.

Before you begin...

Power up the DVR with a monitor and USB mouse connected, then right-click in Live view and select **Configuration**. For more information, see "Accessing the On-screen Display" on page 23

Time/Date Tab

NOTE: Time Zone



Ensure these settings are correct for the customer location/time zone – the DVR date and time are used as an index for searching, archiving, and downloading video, and appear during playback.

To update settings:

1. Select **Time/Date** to display the tab.
2. Select fields and/or use menus to make your changes (menu options are described later in this topic).
For details on entering data with the mouse, see "Using On-screen Keyboards" on page 25
3. Click **Back** to save the settings and return to the Configuration menu.

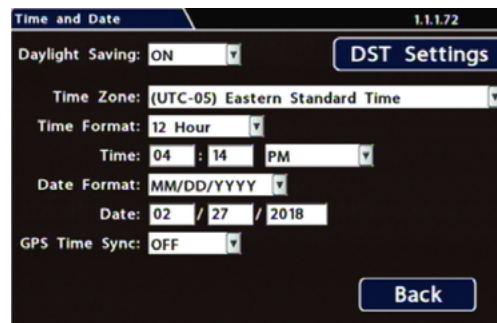

Time and Date Menu Options

| Menu Item | Description | Value [Default] |
|------------------------|--|--|
| Daylight Saving | <p>Leave ON and at default dates unless in an area that does not use daylight savings (e.g. Arizona, Saskatchewan).</p> <p>Click DST Settings and ensure the Start/End dates and times apply to your location.</p> | [ON] |
| Time Zone | Select your local time zone. | [UTC-05 Eastern Standard Time] |
| Time Format | Choose 12 or 24-hour display. | [12 hour]: 12:00 am to 11:59 pm 24 hour: 00:00 to 23:59 |
| Time | Enter the correct time. | |
| Date Format | Select the preferred date format. | [MM/DD/YYYY] YYYY/MM/DD DD/MM/YYYY |
| Date | Set the date for the DVR. | |
| GPS Time Sync | If GPS is installed, set this ON to have the system time automatically updated when satellites are detected. | [OFF] |

Title/Display Menu

About

This topic describes setting up information to display as text when viewing live or recorded video, including the Main Title (generally a vehicle/bus number to identify the video source), as well as the time/date and various system status details.

Before you begin...

Power up the DVR with a monitor and USB mouse connected, then right-click in Live view and select Configuration. For more information, see "Accessing the On-screen Display" on page 23.

Titles and Display Tab

TIP: Changing the default display



All options are set to display by default. You can turn OFF items that are not of interest so the related text will not appear.

1. Select **Title/Display** to open the tab.
2. Enter the bus number in the **Main Title** field (if it is not already there). For more information about using the On-screen keyboard, see "Using On-screen Keyboards" on page 25
3. Choose the desired display settings, as described in "Menu Options", below.
For information about display items, see "Metadata Details" on page 38.

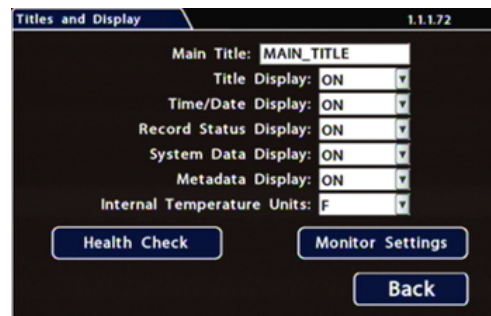

Title/Display Menu Options

| Menu Item | Description | Value [Default] |
|-----------------------------------|--|-------------------|
| Main Title | Enter the bus number. | MAIN_TITLE |
| Titles Display | Display/hide Main Title and Camera Titles | [ON], OFF |
| Time/Date Display | Display/hide time and date | [ON], OFF |
| Record Status Display | Display/hide DVR recording status (LIVE=showing camera feeds, RECORD=storing video, V.LOSS=video loss). | [ON], OFF |
| System Data Display | Display/hide DVR system Metadata: HDD Size, % Full HDD, Voltage, Firmware Version, Fan Failure, and Internal Temperature. For more information, see "Metadata Details" on page 38 . | [ON], OFF |
| Metadata Display | Display/hide DVR Metadata: Signals, GPS, Speed, Ignition State, G-Sensor, and Alarm Count. For more information, "Metadata Details" on page 38. | [ON], OFF |
| Internal Temperature Units | If Metadata Display is ON, display the ambient temperature inside the DVR in degrees. Select F (Fahrenheit) in the USA or C (Celsius) in Canada. | [F], C |

Metadata Details

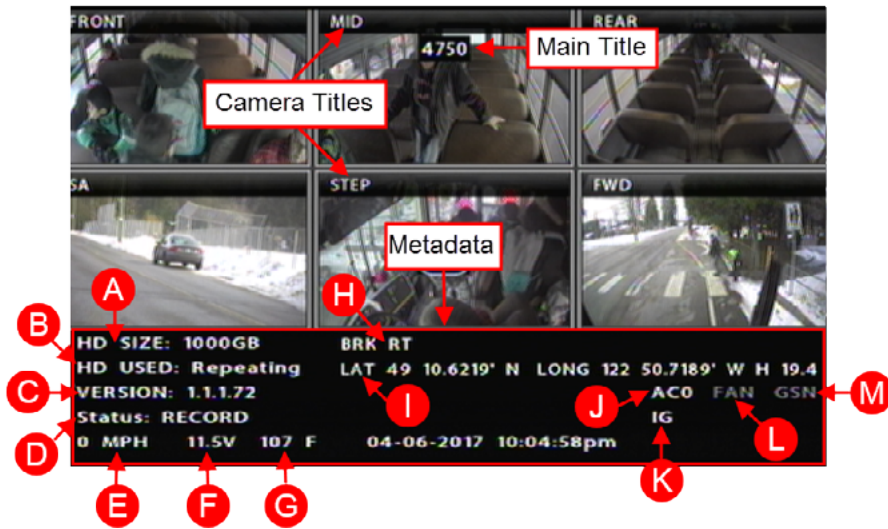

| Reference | Data Item | Description |
|-----------|-------------------|---|
| A | HD Size | Internal drive size (GB). The second value in square brackets displays SD card size in GB. "OFF" appears when storage media is not present. |
| B | HD Used | Percentage of internal drive space used. The second value in square brackets displays percentage of drive spaced used on the SD card. "OFF" appears when storage media is not present. If the Record → Repeat Record setting is ON, displays "Repeating". For more information, see "Recording Settings" on page 46 |
| C | Version | Firmware version. |
| D | Status | DVR status: (LIVE=showing camera feeds, RECORD=storing video, V.LOSS=video loss). |
| E | Speed | Vehicle speed. |
| F | Voltage | System input voltage. |
| G | Temperature | Ambient temperature inside the DVR (F=Fahrenheit, C=Celsius). |
| H | Signals | When a signal activates, the Label is displayed. For more information, see "Signals" on page 41. |
| I | GPS Coordinates | Latitude/longitude, and elevation. If GPS is connected but satellite signals are not being received, zeros appear. |
| J | Alarm Count (AC#) | The current number (1-9) of triggered Alarms. The value resets to 0 when the DVR restarts. For more information, see "Alarms" on page 43 . |
| K | Ignition (IG) | Vehicle ignition state (highlighted=ignition on, dimmed=off). |
| L | Fan | Fan failure notification (highlighted=failure, dimmed=normal) |
| M | G Sensor (GSN) | G Sensor threshold incident (highlighted=threshold exceeded). For more information, see "G Sensor - Menu Options" on page 56. |

Camera Settings

About

This topic describes how to set up camera recording parameters.

Before you begin...

Power up the DVR with a monitor and USB mouse connected, then right-click in Live view and select **Configuration**. For more information, see "Accessing the On-screen Display" on page 23.

Camera Tab

IMPORTANT: Turn off unused camera channels



When a DVR is installed with less than the full number of cameras connected (e.g., for a TH6 DVR, less than 6 cameras), disable the unused camera input settings to prevent the DVR from generating Video Loss (VLoss) events for those camera inputs. In the DVR Configuration menus, disable settings for unused camera inputs as follows:

- Record → FPS → OFF
- Record → Camera Audio → OFF (to save disk space)
- Alarm/Signal → Alarms → FPS → OFF

To configure cameras:

1. Select **Record** → **Camera** to open the tab.
2. Set up the cameras. For details, see Menu Options, below.
3. Click **Back** to save Camera settings, then click Back again to return to the Configuration menu.

| Ch | Source | Title | FPS | Quality | Resolution | Audio |
|----|--------|-----------|--------|---------|------------|-------|
| 1 | IMP | Channel01 | 15 fps | 3 | 1280x720 | ON |
| 2 | SD | Channel02 | 15 fps | 3 | 720x480 | ON |
| 3 | IMP | Channel03 | 15 fps | 3 | 1280x720 | ON |
| 4 | IMP | Channel04 | 15 fps | 3 | 1280x720 | ON |
| 5 | IMP | Channel05 | 15 fps | 3 | 1280x720 | ON |
| 6 | IMP | Channel06 | 15 fps | 3 | 1280x720 | ON |

Buttons: Apply CH1 to All, Camera Advanced, Back

TIP: DVR Recording Limitation



TH6 DVRs cannot record 1080p video at 30 frames per second.

Camera Settings - Menu Options

| Menu Item | Description | Value [Default] |
|---------------------|---|--|
| Title | <p>For each camera, enter a name that describes the view it is recording. For example: "Front", "Step", "Mid", "Rear", "Stop Arm".</p> <p>For instructions on how to enter text with the mouse, see "Using On-screen Keyboards" on page 25.</p> <p>Camera titles display in live views and during playback. For more information, "Metadata Details" on page 38.</p> | [Channel01]... [Channel06] |
| FPS (channel speed) | <p>Leave channel speed at the default setting unless you have special requirements.</p> <p>This sets the recorded frame rate, per second.</p> | [15 fps.], OFF, 1 fps, 5 fps, 7 fps, 10 fps, 15 fps, 20 fps, 30 fps* * TH6 DVRs do not support 1080p @ 30fps. |
| Quality | <p>Leave channel quality at the default setting unless you have special requirements.</p> <p>Setting 1 is the lowest quality, and 4 is the highest. Increased quality involves greater storage requirements. The DVR uses compression technology to extend the amount of video (recording time) that can be stored.</p> | [3], 1, 2, 3, 4 |
| Resolution | <p>Leave channel resolution at the default setting unless you have special requirements.</p> <p>This sets the recording resolution (in pixels). Higher resolution reduces the amount of video (recording time) that can be stored.</p> | SD source: [720x480], 720x240, 360x240 1MP source: [1280x720], 640x360, 320x180 2MP source: [1920x1080] |
| Audio | <p>Leave ON unless the camera is mounted on the exterior of the vehicle, or if you have special requirements.</p> <p>Setting Audio ON enables audio recording for the input channel. Turn OFF Audio for unused camera channels.</p> | [ON], OFF |
| Apply CH1 to All | Click to apply settings selected for Channel 1 to all cameras. | n/a |
| Camera Advanced | Click to access the Camera Advanced tab and adjust settings for each camera with CoC (Control over Coax). | n/a |

Signals

About

This topic describes how to configure signals and the actions they generate. The DVR supports 10 independent signals. The first five are dedicated input wire (signal harness) connections: LT (left turn signal), STP (stop), BRK (brake), WRN (warning lights), and RT (right turn signal). The last five can be set for other functions, such as an excessive speed event or when the installed G-sensor exceeds a threshold.

Before you begin...

Power up the DVR with a monitor and USB mouse connected, then right-click in Live view and select **Configuration**.

For more information, see "Accessing the On-screen Display" on page 23.

Signals Tab

TIP: Signal Labels and Searching for Events



When a signal is activated, the associated 3-character label appears on-screen during video playback. For example, "BRK" appears when the brake pedal is applied. For more information, see "Metadata Details" on page 38.

It is important to understand that you can also search video for signal events. For example, you can find every instance when the warning lights were activated.

For more information, see the [View User Guide](#) (Safe Fleet Community Document Library → SW User Guides → vMax View) and "Working with Video" on page 26.

1. Select **Alarm/Signal** → **Signals** to open the tab.
2. Configure signals as required.
Each signal displays its status (label) when active, and can also trigger an Alarm. For details, see *Menu Options*, below.
3. Click **Back** to save settings, then click **Back** again to return to the Configuration menu.

| Signal | Label | Level | Alarm |
|--------|-------|----------|-------|
| 1 | LT | Active H | OFF |
| 2 | STP | Active H | OFF |
| 3 | BRK | Active H | OFF |
| 4 | WRN | Active H | OFF |
| 5 | RT | Active H | OFF |

Signals 6 to 10

Back

Signals Tab - Menu Options

| Menu Item | Description | Value [Default] |
|---------------|---|---|
| Signal | <p>Signals 1 through 5 are hardwired inputs, received through the signal harness (LT/left turn signal - black wire, STP/stop - green wire, BRK/brake - red wire, WRN/warning lights - brown wire, and RT/right turn signal - white wire). When these triggers are active, they generate signals and display associated labels during video playback.</p> <p>Signals 6 through 10 can be user-defined.</p> | n/a |
| Label | <p>You can edit the on-screen display text label (maximum 3 characters) to describe each signal as desired.</p> <p>For instructions on using the mouse to enter data, see "Using On-screen Keyboards" on page 25.</p> | <p>Labels 1 through 5: [LT], [STP], [BRK], [WRN], [RT].</p> <p>Labels 6 through 10: [S06], [S07], [S08], [S09], [S10]</p> |
| Level | <p>Control how the signal senses activation: choose Active H (high) if the circuit rests at 0 VDC and goes to 12 VDC when active; choose Active L (low) if the circuit rests at 12 VDC and drops to 0 when active.</p> | [Active H], Active L |
| Alarm | <p>Select the alarm number if the signal is also used to trigger an alarm. The alarm's input must also be set up in the Alarms menu. For more information, see "Alarms" on page 43</p> <p>Note: assigning alarms to the default signals 1 through 5 is generally not recommended, since these would be continually triggered by normal vehicle operation.</p> | [OFF], ALM1, ALM2, ALM3, ALM4 |

Alarms

About

This topic describes how alarms work and how to configure them. Triggered alarms create searchable flags in the recorded video, making it easy to locate alarm events and associated Metadata later (for details, see the [View User Guide](#) (Safe Fleet Community Document Library → SW User Guides → vMax View). You can also tell the system to switch to higher recording quality settings when an alarm is triggered - for example, to help identify people or license plates when reviewing video of the event. If the system is wirelessly enabled with Commander, flagged video can be automatically downloaded to your network (for more information, see the [Commander User Guide](#) (Safe Fleet Community Document Library → SW User Guides → vMax Commander).

Before you begin...

Power up the DVR with a monitor and USB mouse connected, then right-click in Live view and select Configuration. For more information, see "Accessing the On-screen Display" on page 23.

Alarm Settings

The DVR supports 4 independent Alarms. By default, Alarm 1 is connected to the optional Event/Diagnostic button installed in the vehicle, for use by the operator (for more information, see "Tagging Video for Review" on page 22). Alarms 2-4 can be triggered automatically by vehicle speed, a G-sensor threshold, GPS fencing, or when a Signal is activated.

To configure Alarms:

1. Select **Alarm/Signal** → **Alarms** to open the tab.
2. Configure Alarm settings as required. For details, see *Menu Options*, below.
3. Click **Back** to save settings, then click **Back** again to return to the Configuration menu.

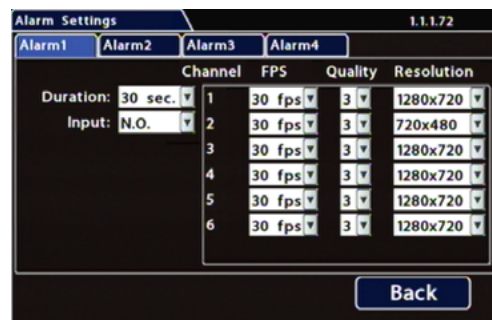

IMPORTANT: Turn off FPS for unused channels



Set **FPS** (Frames per Second) **OFF** for unused channels to avoid DVR video loss events.

TIP: Higher recording quality settings for Alarm events



Select higher speed (**FPS**), **Quality**, and **Resolution** in **Alarm Settings** to increase video quality for a short duration to record an alarm event.

Higher quality video involves greater storage requirements, which reduces the amount of video you can store before it is overwritten. Therefore, a DVR usually records in a mode that conserves storage space.

Alarm Settings - Menu Options

| Menu Item | Description | Value [Default] |
|------------|---|---|
| Alarm | <p>Click to display settings for the selected Alarm.</p> <p>By default, Alarm1 is connected to the DVR Event/Diagnostic button. Alarms 2-4 can come from Signals, GPS geo-fencing, G-sensor, or Excessive Speed.</p> | [Alarm1], Alarm2, Alarm3, Alarm4 |
| Duration | <p>The length of time after the alarm has been triggered that flagged video is recorded at the alarm speed (FPS), quality, and resolution settings described below.</p> | 0, 5, 10, [30] sec., 1, 3, 5, 10, 15, 20, 30, 45 min. |
| Input | <p><i>Applies to Alarm 1 only.</i> When triggered with the Event/Diagnostic button, use the default setting.</p> <p>Control how the alarm input senses activation: choose "N.O." (Normally Open) or N.C. (Normally Closed).</p> | [N.O.], N.C. |
| FPS | <p>For each channel, the recording speed in FPS (Frames Per Second) used when the alarm is triggered.</p> <p>If the DVR normally records at a mid-range or low FPS to conserve storage space, set a higher FPS value to increase video quality for a short duration to record an alarm event.</p> | OFF, 1, 5, 7, 10, 15, 20, [30] FPS |
| Quality | <p>For each channel, the recording quality used when the alarm is triggered.</p> <p>The DVR offers a range of quality settings, from 1 (low) to 4 (high).</p> | 1, 2, [3], 4 |
| Resolution | <p>For each channel, the recording resolution (in pixels) used when the alarm is triggered. The higher the recording resolution, the better the picture looks, but the shorter the recording time on a hard drive.</p> <p>Three options are provided. Details depend on the camera connected to the channel (HD 1080p, HD 720p, or Standard Definition). The highest supported resolution is the default, and two lower-quality options are available.</p> | [1920 x 1080]... [1280 x 720]... [720 x 480]... |

Advanced Configuration

| | |
|------------------------------------|----|
| Recording Settings | 46 |
| Network Settings | 48 |
| Advanced Network Settings | 50 |
| VMS Servers | 52 |
| G Sensor | 54 |
| Speed Settings | 57 |
| GPS Fencing | 58 |
| User Levels..... | 60 |
| System Settings | 62 |
| Program Update..... | 64 |
| Monitor Settings | 66 |
| Wake on Input, Digital Output..... | 68 |
| Customer Service..... | 72 |
| Product Information..... | 72 |
| Warranty | 72 |

Recording Settings

About

This topic describes recording and power settings, including video storage management and options for DVR behavior when the vehicle ignition is turned on/shut down.

Before you begin...

Power up the DVR with a monitor and USB mouse connected, then right-click in Live view and select Configuration.

For more information, see "Accessing the On-screen Display" on page 23.

Record Tab

1. Select **Record** to open the tab.
2. Set the record and power delay timers.
For details, see *Menu Options*, below.
3. Click **Back** to save the settings, or click **Camera** to configure resolution, recording speed/quality, and other camera options.

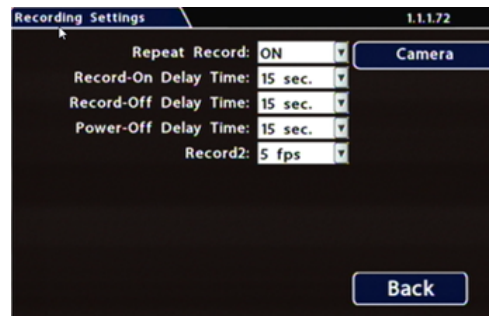

Recording Settings - Menu Options

| Menu Item | Description | Value [Default] |
|-----------------------|---|---|
| Repeat Record | <p>Leave this setting at the default [ON] for the storage media to loop, and record over the oldest video when it becomes full (the "HD Used" Metadata item displays "Repeating" - for more information see "Metadata Details" on page 38).</p> <p>When set to OFF, the DVR stops recording when storage is full ("HD Used" displays 100%).</p> | [ON], OFF |
| Record-On Delay Time | <p>Leave at default to let the voltage settle after the vehicle starts up to prevent voltage drops affecting the DVR.</p> <p>Enables a time delay after the vehicle ignition is turned on until the DVR starts.</p> | [15 sec.], 30 sec., 1 min., 5 min., 10 min., 20 min., 30 min. |
| Record-Off Delay Time | <p>To keep the DVR and cameras on after the ignition turns off (e.g. to record the post-trip check), set this to 10 or 20 min.</p> <p>Enables a time delay to continue recording after the ignition signal to the DVR is turned off. The power output connector on the DVR rear panel remains active during this time.</p> | [15 sec.], 30 sec., 1 min., 5 min., 10 min., 20 min., 30 min. |
| Power-Off Delay Time | <p>If the system is not using Wi-Fi, use the default setting. If Wi-Fi is used, set to 2 hours or more. For more information, see the Commander User Guide (Safe Fleet Community Document Library → SW User Guides → vMax Commander).</p> <p>This sets the time delay from the record delay until power is shut off. The delay begins after "Record Delay Off" time ends. During this time, cameras are turned off and recording is stopped. However, the control connector on the DVR rear panel remains active to allow peripherals such as Smart-Reach to be powered up during the power delay time.</p> | [15 sec.], 0 sec., 30 sec., 1 min., 5 min., 10 min., 20 min., 30 min., 45 min., 1 hr., 2 hr., 4 hr. |
| Record2 | <p>Leave at the default setting unless instructed otherwise.</p> <p>Unless set to OFF, the DVR records a low resolution second video stream at the selected frame rate. The DVR can record video in two streams: one at high resolution for full, detailed event information, and the other (Record2) at lower resolution for fast downloading or real-time viewing over a low bandwidth network such as a cellular link. In the event of an emergency, if the system is configured with Smart-Reach cellular hardware and a cellular plan, Record2 allows quick access to video online. Use the Record2 setting to specify a lower per second recording (frame rate) for the second video stream.</p> | [5 fps], OFF, 1 fps, 2 fps, 3 fps, 4 fps, 5 fps |

Network Settings

About

This topic describes the communication parameters required to use Smart-Reach Mobile wireless bridge equipment and Ethernet to connect the DVR to computers and networks.

More information on related products and features is available from:

[Commander User Guide](#) (Safe Fleet Community Document Library → SW User Guides → vMax Commander)

[View User Guide](#) (Safe Fleet Community Document Library → SW User Guides → vMax View)

Before you begin...

Power up the DVR with a monitor and USB mouse connected, then right-click in Live view and select Configuration.

For more information, see "Accessing the On-screen Display" on page 23.

Network Tab

NOTE: Configuring Network Settings and Advanced Network Settings

A qualified IT administrator is required to provide information and configure Network Settings and Advanced Network settings.

i

These tasks should only be performed by engineering services or the fleet system administrator.

- Each host (computer) connected to the network must have a unique IP address.
- If the DVR is attached to a WiFi bridge, change these settings to those supplied by the system administrator.
- If the IP information is changed and saved in a configuration file for upload to other DVRs, their settings must also be updated. For more information, see TH Configuration: Copying DVR Configuration.

Contact Technical Support to assign an IP address or reset the Smart-Reach Mobile wireless bridge, or for more information.

To configure Network Settings:

1. Select **Network** to open the tab.
2. Configure settings as required.
For details, see *Menu Options*, below.
3. Click **Back** to save changes and return to the Configuration menu.

Network Settings 1.1.172

Setting Type: Static IP

IP Address: 169 254 1 1

Subnet Mask: 255 255 0 0

LAN Gateway: 169 254 1 1

DNS Server: 0 0 0 0

MAC Address: 00:1c:3c:02:00:29

HTTP Port: 80

Advanced User Levels Back

Network Settings - Menu Options

| Menu Item | Description | Value [Default] |
|--------------|---|------------------------|
| Setting Type | <p>Contact your administrator to configure the setting type and IP address</p> <p>OFF disables all Ethernet capability.</p> <p>Static IP is a permanent address on the network, assigned by the network administrator. DHCP (Dynamic Host configuration Protocol) automates the assignment of IP addresses in a network.</p> <p>If DHCP is used, the subnet mask, default gateway, and DNS server are configured automatically, and only the HTTP Port field is editable.</p> | [Static IP], OFF, DHCP |
| IP Address | Enter the DVR IP Address, as determined by a qualified network expert. | [169.254.1.1] |
| Subnet Mask | Enter the Subnet Mask, as determined by a qualified network expert. | [255.255.0.0] |
| LAN Gateway | Gateway address uniquely identifies a host or computer on the LAN, which connects the subnet to other networks. Enter the LAN Gateway, as determined by a qualified network expert. | [169.254.1.1] |
| DNS Server | Uses an IP address composed of four octets, separated by decimals. | [0,0,0,0] |
| MAC Address | MAC (Media Access Control) is the DVR's unique hardware number. | Fixed |
| HTTP Port | Typically, leave the HTTP Port set to 80, unless otherwise instructed by IT personnel. | 80 |

Advanced Network Settings

About

This topic describes the communication parameters required to enable the DVR for vMax Live Plus, a Web-based solution providing GPS for Automatic Vehicle Location and telemetry data for monitoring vehicle sensors.

For more information, see the [View User Guide](#) (Safe Fleet Community Document Library → SW User Guides → vMax View).

Before you begin...

Power up the DVR with a monitor and USB mouse connected, then right-click in Live view and select Configuration.

For more information, see "Accessing the On-screen Display" on page 23.

Advanced Settings Tab (vMax Live Plus)

Use this tab to set up the DVR to connect with vMax Live Plus via a cellular modem. For more information, see the [vMax Live Plus](#) documentation (Safe Fleet Community Document Library → SW User Guides → vMax Live Plus).

NOTE: Qualified IT Administrator Required



A qualified IT administrator is required to perform network configuration, including assignment of IP addresses.

A cellular modem or gateway must also be installed and configured.

Contact Technical Support for more information.

To configure Advanced Network Settings:

1. Select **Network** → **Advanced** to open the tab.
2. Configure settings as required.
For details, see *Menu Options*, below.
3. Click **Back** to save changes, then click **Back** again to return to the Configuration menu.

| Advanced Setting | | 1.1.1.72 | |
|------------------|------------|--------------|--|
| Integrated VML: | ON | Subnet Mask: | |
| LAN Range: | 0 0 0 0 | / 16 | |
| IVML IP Address: | 172 30 2 2 | / 24 | |
| Default Gateway: | 172 30 2 1 | | |

VMS Servers

Back

Advanced Network Settings - Menu Options

| Menu Item | Description | Value [Default] |
|----------------------------|--|-----------------|
| Integrated VML (vMax Live) | Set ON to enable the integrated VML feature. OFF disables the integrated VML feature. | [OFF], ON |
| LAN Range | If the customer network is outside of the DVR network: set the customer network's LAN range as determined by a qualified network expert. Note: There must be a value in this field. If not used, enter a dummy IP address such as 10.10.0.0. | [0.0.0.0] |
| LAN Subnet Mask | Set the LAN subnet mask used for the LAN Gateway Destination range as determined by a qualified network expert. Use a value between 0 and 32. | [16] |
| iVML IP Address | Enter the iVML IP Address as determined by a qualified network expert. | [172.30.2.2] |
| iVML Subnet Mask | Set the subnet mask for the iVML IP Address as determined by a qualified network expert. Use a value between 0 and 32. | [24] |
| Default Gateway | Enter the Default Gateway IP address for communicating with the cellular modem, as determined by a qualified network expert. | [172.30.2.1] |

VMS Servers

About

This topic describes setting up communication parameters required to enable the DVR for Commander software. Commander remotely schedules and displays downloaded alarm video archives, tracks vehicles, and runs reports on fleet activity.

For more information, see the [Commander User Guide](#) (Safe Fleet Community Document Library → SW User Guides → vMax Commander).

Before you begin...

Power up the DVR with a monitor and USB mouse connected, then right-click in Live view and select Configuration.

For more information, see "Accessing the On-screen Display" on page 23.

VMS Servers Tab (Commander Settings)

NOTE: Qualified IT Administrator Required



A qualified IT administrator is required to perform network configuration, including assignment of IP addresses.

A wireless bridge and an access point must also be installed and configured.

Contact Technical Support for more information.

To configure VMS Servers:

1. Select **Network** → **Advanced** → **VMS Servers** to open the tab.
2. Configure settings as required.
For details, see *Menu Options*, below.
3. Click **Back** to save changes, then click **Back** on successive screens to return to the Configuration menu.

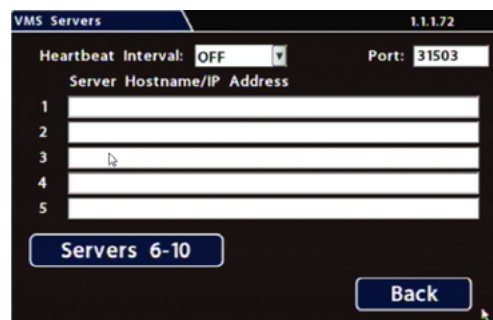

VMS Servers - Menu Options

| Menu Item | Description | Value [Default] |
|---------------------|---|--|
| Heartbeat Interval | As determined by a qualified network expert, select an interval to transmit DVR status messages to all available VMS Servers. We recommend a Heartbeat Interval setting of one minute. | [OFF], 1 min, 2 min, 3 min, 4 min, 5 min |
| Port | Enter a Port for VMS Heartbeat communication as determined by a qualified network expert. We recommend the default Port setting. | [31503] |
| Servers 1 to 10 | | |
| Hostname/IP Address | Up to 10 server hostnames or IP addresses that can receive VMS heartbeat messages from the DVR as determined by a qualified network expert. | Maximum 64 characters. |

G Sensor

About

This topic describes calibrating and configuring the optional G Sensor (inertia sensor), which records vehicle acceleration, deceleration, and lateral motion data. The information can be used to provide information about driver behavior and vehicle accidents.

Before you begin...

The G Sensor must be properly installed and connected, as described in this topic. For more information see the [TH6 Quick Install Guide](#) on the inView Guardian product page.

Power up the DVR with a monitor and USB mouse connected, then right-click in Live view and select Configuration. For more information, see "Accessing the On-screen Display" on page 23.

G Sensor Tab

NOTE: Calibration



The G Sensor must be calibrated when initially installed or if the unit is relocated, and the procedure must be performed on the vehicle (i.e. not by connecting to the DVR from a remote location).

G Sensor settings can be adjusted to fit specific requirements. Note that if thresholds are set too low and alarms are enabled, many alarms may be generated. Details are provided below.

1. Select **Alarm/Signal** → **G Sensor** to open the tab.
2. **If this is a new system installation, or the G Sensor unit has been relocated:**
 - **Skip to the next page, and follow the *G Sensor Calibration* procedure.**
3. If required, adjust G Sensor settings. For details, see *Menu Options*, below.
4. Click **Back** to save settings, then click **Back** again to return to the Configuration menu.

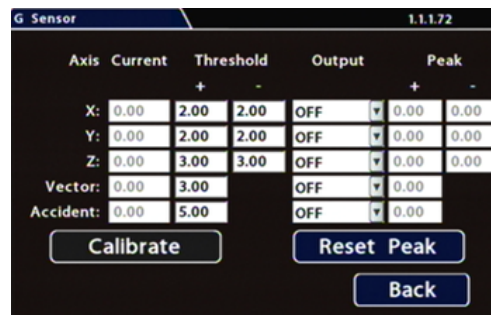

TIP: Default G Sensor Settings



We recommend the default G Sensor settings for large bus movement detection.

Smaller vehicles may require lower thresholds - some experimentation may be necessary to define the optimal configuration for each vehicle type. If thresholds are set too low, they may generate many alarms.

G Sensor Calibration

Ensure the G Sensor unit is mounted securely, with the arrow toward the front of the vehicle.

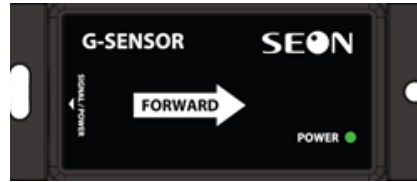

The unit connects to the G SENSOR port on the DVR rear panel. For more information see the [TH6 Quick Install Guide](#) on the inView Guardian product page.

1. Open **Configuration** → **Alarm/Signal** → **G Sensor**, and click **Calibrate**.

The X, Y, and Z axis planes are set, based on the mounting surface.

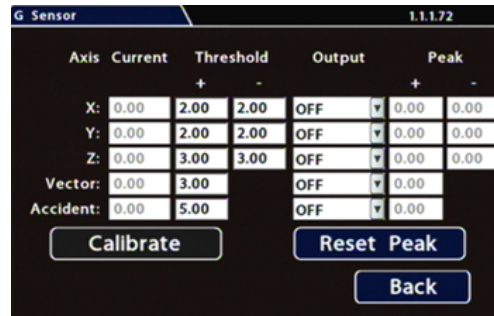

3. When the process is complete, click **OK** in the confirmation dialog.
4. If required, adjust G Sensor settings. For details, see *Menu Options*, below.
5. Click **Back** to save settings, then click **Back** again to return to the Configuration menu.

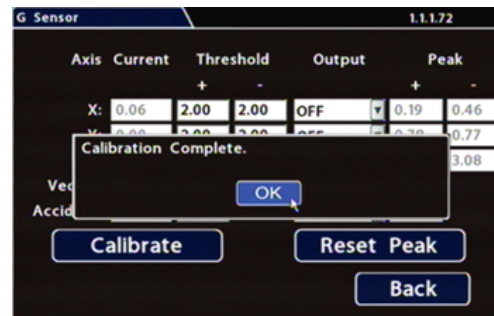

G Sensor - Menu Options

| Menu Item | Description | Value [Default] |
|-----------|--|--|
| Axis | X - forward/back axis Y - left/Right axis Z - vertical axis Vector - combination of X and Y axes (to capture driver behavior incidents) Accident - combination of X and Y axes (higher threshold settings, to capture vehicle accidents) | n/a |
| Current | The current (live) values measured by the G Sensor (display only) | n/a |
| Threshold | Set from 0G to 6.0G. This value configures the threshold level. Any value beyond the threshold triggers the output, as configured in the Output field. | X = [+/- 2.00] Y = [+/- 2.00] Z = [+/- 3.00] V = [+ 3.00] A = [+ 5.00] |
| Output | If the specified G Sensor threshold value is exceeded, the DVR triggers the selected output (DVR log entry, Signal, or Alarm). | [OFF], Log, S01-S10, ALM1- ALM4 |
| Peak | Use the observed peak values to refine threshold settings. Peak values reflect detected G Sensor levels for axis, Vector, and Accident activity. | n/a |

Speed Settings

About

This topic describes how to set options for recording vehicle speed data and triggering notifications for excessive speed.

Before you begin...

Power up the DVR with a monitor and USB mouse connected, then right-click in Live view and select Configuration.

For more information, see "Accessing the On-screen Display" on page 23.

Speed Tab

1. Select **Alarm/Signal** → **Speed** to open the tab.
2. Configure speed settings as desired.
For details, see Menu Options, below.
3. Click **Back** to save settings, then click **Back** again to return to the Configuration menu.

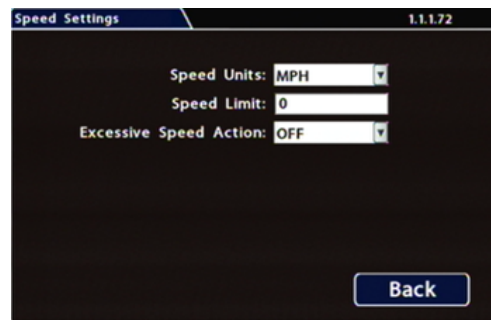

Menu Options

| Menu Item | Description | Value [Default] |
|------------------------|--|--|
| Speed Units | Choose MPH in the US, or KPH in Canada. The speed display units; the GPS signal is converted to display speed in the selected units. | [MPH] - Miles per hour, KPH - Kilometers per hour, KTS - Knots |
| Speed Limit | Enter a speed limit to trigger notifications. If an Excessive Speed Action is selected, this value triggers a notification if exceeded by vehicle speed. | [0] |
| Excessive Speed Action | Settings other than OFF trigger the selected action (S1-S10=Signal, ALM1-ALM4=Alarm, Log=DVR log entry) when the vehicle exceeds the specified Speed Limit. | [OFF], Log, S1 - S10, ALM1 - ALM4 |

GPS Fencing

About

This topic describes how to set GPS fencing (geofence) options. A geofence defines a designated circular or rectangular geographic area, based on GPS coordinates (latitude/longitude). If the vehicle leaves the geofenced area, the DVR can trigger an Alarm.

Before you begin...

Power up the DVR with a monitor and USB mouse connected, then right-click in Live view and select Configuration.

For more information, see [Accessing the On-screen Display](#) pg. 23.

GPS Tab

1. Select **Alarm/Signal** → **GPS** to open the tab
2. Configure **Fencing Alarm** settings as required.
For details, see *Menu Options*, below.
3. Click **Back** to save settings, then click **Back** again to return to the Configuration menu.

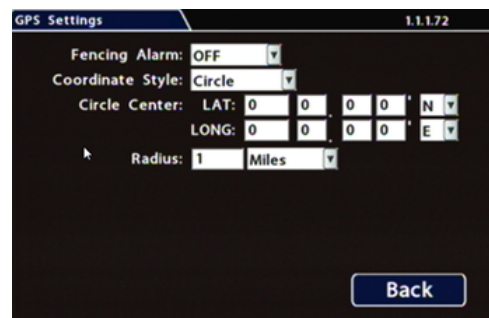

GPS Fencing - Menu Options

| Menu Item | Description | Value [Default] |
|------------------|---|---------------------|
| Fencing Alarm | ALM settings trigger the selected Alarm when the vehicle crosses the fencing boundary, as defined by the selected coordinate style. | OFF], ALM1 - ALM4 |
| Coordinate Style | Circle - sets the area for GPS fencing by identifying the center point and radius. This option only displays "Circle center" and "Radius" data entry fields. Rectangle - Sets the area for GPS fencing by upper left and lower right rectangular coordinates. This option only displays the "Top Left" and "Bottom Right" data entry fields. | [Circle], Rectangle |
| Circle Center | Enter latitude and longitude of the fencing center point. | [000.00.00] |
| Radius | Define the size of the fencing area diameter, in miles or kilometers. | [1 Mile] |
| Top Left | Enter the latitude and longitude of the top left point of the fencing area. | [000.00.00] |
| Bottom Right | Enter the latitude and longitude of the bottom right point of the fencing area. | [000.00.00] |

User Levels

About

This topic describes creating DVR user logon profiles and assigning passwords to enable multiple users remote access to the DVR with various permission levels.

For more information on remote access to the DVR, see the [Commander User Guide](#) (Safe Fleet Community Document Library → SW User Guides → vMax Commander).

Before you begin...

Power up the DVR with a monitor and USB mouse connected, then right-click in Live view and select Configuration.

For more information, see "Accessing the On-screen Display" on page 23.

User Levels Tab

NOTE: Password Control



Users logging on to the DVR should have password control to protect the DVR from being accidentally reconfigured. The default password is 11111111.

For security purposes, we recommend changing default login and system settings passwords.

Keep a copy of your password in a secure place, in case it is lost or forgotten.

To configure User Levels:

1. Select **Network** → **User Levels** to open the tab.
2. The default "Admin" user cannot be changed. Add other users with access levels as required. Enter user names, passwords, and assign levels. For details, see *Menu Options*, below.
3. Click **Back** to save changes, then click **Back** again to return to the Configuration menu.



User Levels - Menu Options

| Menu Item | Description | Value [Default] |
|-----------|--|--|
| Name | User names for remote access to the DVR. Names are case-sensitive, maximum 8 characters. | [Administrator] for User 1 [Blank] for other Users |
| Password | Set a password for each user - maximum 8 characters. | [11111111] |
| Level | Assign each remote user a specific access level: Administrator - complete DVR control; only Administrators can change User Levels. Playback - only viewing and archiving recorded video and viewing live video Configure - playback rights, plus general DVR configuration (<i>cannot edit User Levels</i>). | [Administrator] for User 1, [Playback] for other Users, |

System Settings

About

This topic describes how to configure various system-level settings, including a password for local access to the DVR.

Before you begin...

Power up the DVR with a monitor and USB mouse connected, then right-click in Live view and select Configuration.

For more information, see "Accessing the On-screen Display" on page 23.

System Tab

NOTE: Authorized Individuals



This tab allows control of system-level settings and functions that should only be changed by authorized individuals.

The Password applies to local DVR access, and generates a prompt when the unit powers up, before any other features become available. The default password is 11111111. For security purposes, we recommend changing the default password. Keep a copy of your password in a secure place, in case it is lost or stolen.

To configure System Settings:

1. Select **System** to open the tab.
2. Adjust system settings as required.
For details, see *Menu Options*, below.
3. Click **Back** to save changes.

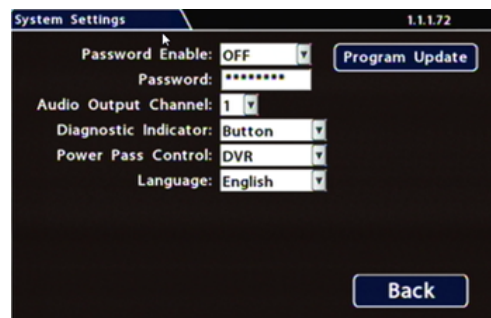

System Settings - Menu Options

| Menu Item | Description | Value [Default] |
|----------------------|---|------------------------------|
| Password Enable | When set to ON, local access to the DVR On-screen Display (including all DVR control, configuration, and playback features) requires the System Settings password. | [OFF], ON |
| Password | Maximum 8 digits. | [11111111] |
| Audio Output Channel | Select the audio channel output through AUDIO RCA connector on the DVR front panel. | [1], 2-6 |
| Diagnostic Indicator | Select the type of system status indicator installed in the vehicle (for more information, see "Video System Status1" on page 20). | [Button], RGY Illum |
| Power Pass Control | Controls how another device connected to the PWR THRU port on the DVR rear panel receives battery power from the vehicle (for more information, see "DVR Back Panel Features" on page 19): DVR - send power to the device only while the DVR is on. Thru - send power to the device whether or not the DVR is on. | [DVR], Thru |
| Language | Select a language for the DVR On-screen Display and vMax Web UI. | [English}, Espanol, Francais |

Program Update

About

This topic describes options on the **System Settings** → **Program Update** tab, which are used to:

- Install DVR firmware updates
- Copy DVR setup details to a configuration file
- Apply settings from a configuration file to the DVR
- Format DVR storage media (hard drive or SD card)

For firmware installation procedures: see "Firmware Updates" on page 13.

For full instructions on copying settings and applying them to other DVRs: see "Copying DVR Configuration" on page 14.

Before you begin...

Power up the DVR with a monitor and USB mouse connected, then right-click in Live view and select Configuration.

For more information, see "Accessing the On-screen Display" on page 23.

Program Update Tab

To perform program updates:

1. Select the **System Settings** → **Program Update** to open the tab.
2. Choose options as required.
For details, see *Menu Options*, below.
3. Click **Back** to save changes.

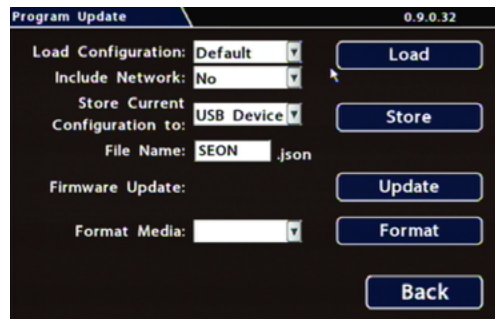

Program Update - Menu Options

For full instructions on loading DVR settings, see "Copying DVR Configuration" on page 14.

For firmware installation procedures, see "Firmware Updates" on page 13.

| Menu Item/Button | Description | Value [Default] |
|--------------------------------|---|-----------------------------|
| Load Configuration | Load configuration settings from a USB device or local storage on the DVR. Default loads the factory settings. The drop-down list displays the 10 most recent configuration files saved on the USB. MEM1 is a customized configuration setting saved locally on the DVR. | [Default], MEM1 |
| Load | Click to load DVR configuration settings, | n/a |
| Include Network | Choose whether to overwrite existing DVR network settings when loading a configuration. No keeps existing (local) DVR network settings. Yes overwrites DVR network settings with configuration from the file. | [No], Yes |
| Store Current Configuration to | Store DVR configuration settings to a USB device or DVR memory location (MEM1). | [USB Device], MEM1 |
| Store | Click to store the DVR's current configuration to a USB device. | n/a |
| File Name | Set a file name for the configuration you are saving. | [SEON] Max. 4 characters |
| <Firmware> Update | Click Update to upgrade the firmware from a USB device. | n/a |
| Format Media | Select storage media to format. | [Hard Drive], SD Card, Both |
| Format | Click to Format the selected storage media. | n/a |

Monitor Settings

About

This topic describes the Monitor Settings tab. It provides options to control the camera feed displayed in the DVR's On-screen Display "Live View". Monitor Settings also apply to the FRC inView TrueSight for vehicles. For more information, see the [FRC BCA100/200 inView TrueSight™ \(Wired System\) manual documentation](#) on the left side of the inView TrueSight product page online.

Before you begin...

Power up the DVR with a monitor and USB mouse connected, then right-click in Live view and select Configuration.

For more information, see "Accessing the On-screen Display" on page 23.

Monitor Settings

Monitor Settings control camera feeds sent to both the Video Out RCA jack on the DVR front panel and the Expansion socket on the rear panel. For more information, see "DVR Front Panel Features" on page 18 and "DVR Back Panel Features" on page 19.

TIP: Custom Monitor Displays



In addition to Rear Vision Systems (backup cameras), Monitor Settings can support custom implementations such as an entry/exit bus door camera with a dedicated monitor to advertise the fact that riders are under surveillance.

To configure Monitor Settings:

1. Select **Title/Display** → **Monitor Settings** to open the tab.
2. Configure options as required.
For details, see *Menu Options*, below.
3. Click **Back** to save settings, then click **Back** again to return to the Configuration menu.

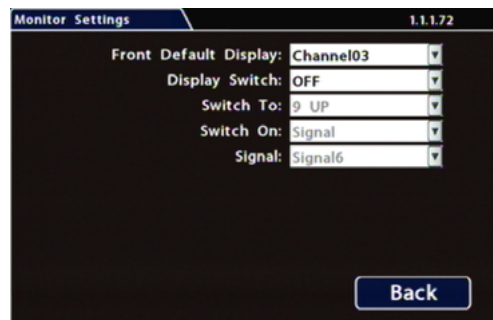

Monitor Settings - Menu Options

| Menu Item | Description | Value [Default] |
|-------------------------|---|---|
| Front Default Display | Select the default monitor display setting: all cameras (# UP) or a single camera (choose the Channel it is connected to). | [# UP], Channel 01... |
| Display Switch | Enable or disable switched display. Select ON if you want to switch the monitor display from the default setting to another camera feed based on an Alarm, a Signal, or a specified time, as per the options detailed below (these parameters are unavailable when Display Switch is OFF). | [OFF], ON |
| Switch To | When Display Switch is ON, select the camera feed to activate based on the Alarm, Signal, or Timer setting described below. You can choose to display a single camera (by Channel number), all connected cameras (# UP), or to show each active camera feed in sequence (Sequence - applies only to the Timer option described below). | Channel 01..., [# UP], Sequence |
| Switch On | Set the trigger type that will activate the camera feed selected in the Switch To setting and cause it to display in the monitor output. Then, from the pull-down menu below, select a specific Alarm, Signal, or Timer setting. | Alarm, [Signal], Timer |
| Alarm (Signal or Timer) | For Alarm or Signal trigger types: choose the specific Alarm/Signal to activate the selected camera view in the monitor output display when Display Switch is ON . For example, the ALM1 setting switches monitor output to the view selected in the Switch To option for the duration of ALM1. For the Timer trigger type: select the amount of time each active video channel displays during rotation. For example, 10sec changes channels between valid camera inputs every 10 seconds. | [ALM 1]... [Signal 1]... [3 sec.], 5 sec, 10 sec. 30 sec. |

Wake on Input, Digital Output

About

This topic describes setting the optional features available in the **Alarm/Signal** → **Others** tab:

- Wake on Input - triggers the DVR to automatically power up (and optionally start recording).
- Digital Output - sends a signal to an external device upon an Alarm or Video Loss event.

Before you begin...

Power up the DVR with a monitor and USB mouse connected, then right-click in Live view and select Configuration.

For more information, see "Accessing the On-screen Display" on page 23.

The "Others" Tab

1. Select **Alarm/Signal** → **Others** to open the tab.
2. Configure settings as desired.
For details, see *Menu Options*, below.
3. Click **Back** to save settings, then click **Back** again to return to the Configuration menu.

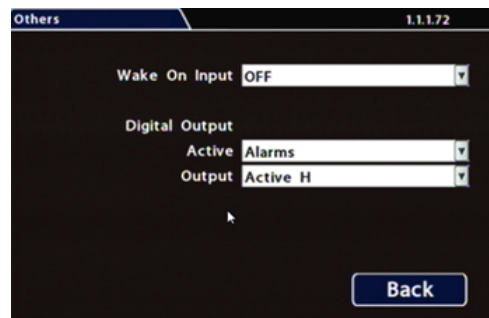

TIP: Expansion and Adapter Ports



- **Wake on Input** utilizes a connection to the DVR through the Signals port, via the Adapter Harness.
- **Digital Output** sends a signal to the external device through the DVR Expansion port.

For more information, see the FRC [TH6 Quick Install Guide](#) on the left side of the inView Guardian product page online.

Wake on Input, Digital Output - Menu Options

| Menu Item | Description | Value [Default] |
|-------------------------|---|---------------------------|
| Wake on Input | <p>Select the input action that wakes up the DVR:</p> <p>OFF: the DVR ignores the Wake on Input signal.</p> <p>TEMP PWR: the DVR wakes into temporary power mode (boots up and stays powered for 5 minutes).</p> <p>ALM1: DVR powers on and enters Alarm 1 mode (as per the configured Alarm 1 duration and recording settings).</p> <p>For more information see "Alarms" on page 43.</p> | [OFF], ALM1, TEMP PWR |
| Digital Output (Active) | <p>Select the type of system events which, if detected, generate a DVR output signal to an external device through the Expansion port.</p> <p>Alarms: the DVR generates an output whenever an alarm is detected.</p> <p>Video Loss: the DVR generates an output whenever an video loss event is detected.</p> | [OFF], Alarms, Video Loss |
| Digital Output (Output) | <p>Select the type of signal generated when Digital Output is triggered:</p> <p>Active H: the Digital Output circuit rests at 0 VDC and goes to 12 VDC when active.</p> <p>Active L: circuit rests at 12 VDC and drops to 0 when active.</p> | [Active H], Active L |

— THIS PAGE INTENTIONALLY LEFT BLANK —

— THIS PAGE INTENTIONALLY LEFT BLANK —

Customer Service

FRC Customer Service and Product Support:

(8am to 5pm EST weekdays)

- Main Phone: 631.724.8888
- Fax: 631.360.9727 (24 hours)
- Website: [Contact FRC](#)

If your DVR is to be returned, please contact Technical Support, and provide the model and/or serial number of your unit. Ask for a Return Merchandise Authorization (RMA) number. An RMA number allows the Service Technicians to better track your product when it comes in for service. Please show the RMA number on the outside of the package. ANY RETURNED PRODUCT WITHOUT AN RMA NUMBER MAY BE REFUSED.

Product Information

For product information and documentation related to the TH6 Hybrid 6-Camera system, please visit the inView Guardian product page on the [FRC Website](#).

Or, for additional information, you may wish to visit [Safe Fleet Community website](#). Please contact FRC Service for the username and password to this online help community website. If you do not have access credentials, please contact Technical Support.

Warranty

Complete warranty details are available online:

[FRC Limited Warranty Page](#)