



A Safe Fleet Brand

DRYGEAR PROFESSIONAL

DRYING SYSTEM ASSEMBLY AND OPERATING MANUAL

DRY GEAR PRO



DRY GEAR PLUS w/Removable Hangers



FIRE RESEARCH CORPORATION

www.fireresearch.com

26 Southern Blvd., Nesconset, NY 11767

TEL 631.724.8888 FAX 631.360.9727 TOLL FREE 1.800.645.0074

CONTENTS**Table of Contents**

CONTENTS.....	2
INTRODUCTION	3
Overview.....	3
Specifications	4
ASSEMBLY INSTRUCTIONS.....	5
Pre-Assembly.....	5
Tools Required.....	5
General Notes	7
Assemble Blower Assembly and Transfer Tube.....	8
Assemble Manifolds and Tent Frame Long Angles (6, 7, and 8 Station Only)...	10
Assemble Legs.....	12
Install Blower Assembly Legs.....	14
Assemble Tent Frame	16
Assemble Manifold, Tent Frame, and Muffler.....	18
Install Hanger and Glove Post	20
Install Tent Enclosure	22
Install Optional Caster Kit.....	24
WIRING POWER.....	26
OPERATION	28

List of Tables

Table 1. Hardware.....	5
Table 2. Parts and Assemblies.....	6

List of Figures

Figure 1. DryGear System Parts	7
Figure 2. Blower Assembly and Transfer Tube	9
Figure 3. Manifold and Tent Frame Long Angles.....	11
Figure 4. Leg Assemblies.....	13
Figure 5. Blower Assembly Legs.....	15
Figure 6. Tent Frame	17
Figure 7. Manifold, Tent Frame, and Muffler	19
Figure 8. Hanger and Glove Post.....	21
Figure 9. Tent Enclosure	23
Figure 10. Caster Kit.....	25
Figure 11. Wiring Power.....	27
Figure 12. Control Box Panel	29

INTRODUCTION

Overview

The DryGear system provides a closed environment for the drying of bunker gear, hose, and loose equipment.

Warm air is delivered through a manifold to multiple stations with hanger and glove assemblies. It is circulated within a tent enclosure to dry the interior and exterior of coats, bunker pants, boots, helmets, gloves, hoods, and other equipment.

Tent Enclosure

The tent enclosure is made of cross weaved polyester vinyl with a clear front cover. It is supported by an overhead frame and encloses the entire DryGear system rack. The front cover has pull down zippers to seal the sides and rolls up to allow complete access to the interior of the tent enclosure (6, 7, and 8 station configurations also have a zipper down the middle of the front cover).

Blower Assembly

The blower assembly includes the blower and blower motor, heater element, thermistor, and control box. It supplies warm air to the manifold through the transfer tube. The air intake for the blower is located inside the tent enclosure to increase the circulation of warm air. A muffler is attached to the air intake to reduce noise and vibration. A screen on the intake prevents gear from being sucked in. Overheat protection of the heater element is provided by an internal thermistor.

Control Box

The control box is mounted on the transfer tube. The BLOWER & HEATER HOURS timer switch, SELECT switch, and HEATER SELECTED light are mounted in the control box. Power to the control box for the DryGear system is supplied from a local 220 volt 30 amp source.

Manifold

The manifold delivers forced air from the blower and transfer tube to the glove posts, hangers, and DryGear system enclosure.

Options

An optional caster kit is available.

Ventilation

The DryGear system does not require separate ventilation. If the system is set up in a small enclosed room, it is recommended that the room be vented to remove any warm moist air.

Specifications

The DryGear system is available in 3, 4, 6, 7, and 8 station configurations.

Electrical Requirements

220 VAC; 30 AMP

Motor (3, 4, and 6 Station Configuration)

HP: 3
Volts: 208 / 230
Amps: 15.5 / 15.3

Motor (7 and 8 Station Configuration)

HP: 5
Volts: 220
Amps: 19.6

Heater

Power: 2400 Watts
Current Maximum: 10 AMPS
Thermistor: 180 °F cutoff
Timer: 6 Hours

Dimensions

Length: 3 station configuration: 71 inches
4 station configuration: 86 inches
6 station configuration: 121 inches
7 station configuration: 138 inches
8 station configuration: 153 inches
Width: 37 inches
Height: 84 inches (with caster kit option add 3 3/4 inches)

Material

Tubing: Aluminum square and round tubing
Enclosure: Rip-stop polyester vinyl

ASSEMBLY INSTRUCTIONS

Pre-Assembly

Before assembling the DryGear system, verify that all loose hardware, parts, and assemblies are on hand. Refer to the column in Tables 1 and 2 that reflects the station configuration to be assembled. (Some hardware, parts, or assemblies may be put together at the factory prior to shipping.)

Tools Required

5/32 and 3/16 Inch Hex Key

7/16, 1/2, and 9/16 Inch Wrench

Rubber Mallet

Table 1. Hardware

Description	3-Station	4-Station	6-Station	7-Station	8-Station
Screw, Flat Head Socket Cap, S/S, 1/4-20 x 1/2"	12	12	24	24	24
Screw, Socket Cap, S/S, 1/4-20 x 3/4"	28	28	44	44	44
Screw, Socket Cap, S/S, 1/4-20 x 1 1/4"	16	16	16	16	16
Screw, Socket Cap, S/S, 1/4-20 x 2 1/2"	8	8	8	8	8
Nut, S/S, 1/4-20	8	8	8	8	8
Washer, Flat, S/S, 1/4"	52	52	68	68	68
Screw, Hex Head, S/S, 5/16-18 x 3/4"	4	4	8	8	8
Screw, Hex Head, S/S, 5/16-18 x 2 1/4"	2	2	2	2	2
Nut, S/S, 5/16-18	2	2	2	2	2
Washer, Flat, S/S, 5/16"	8	8	12	12	12
Washer, Lock, S/S, 5/16"	4	4	8	8	8
Screw, Hex Head, S/S, 3/8-16 x 1"	4	4	4	4	4
Nut, S/S, 3/8-16	4	4	4	4	4
Washer, Flat, S/S, 3/8"	8	8	8	8	8
Washer, Lock, S/S, 3/8"	2	2	2	2	2

Table 2. Parts and Assemblies

Description	3-Station	4-Station	6-Station	7-Station	8-Station
Blower Assembly	1	1	1	1	1
Blower Assembly Mount ¹	1	1	1	1	1
Muffler ¹	1	1	1	1	1
Leg Assembly	4	4	4	4	4
5th Leg Assembly ¹	1	1	1	1	1
Leg Brace, Blower Side	1	1	1	1	1
Leg Brace, Non-Blower Side	1	1	1	1	1
Transfer Tube	1	1	1	1	1
Manifold, 3-Station, 50"	1	0	2	1	0
Manifold, 4-Station, 65"	0	1	0	1	2
Backing Plate ²	4	4	4	4	4
Manifold Joining Plate ³	0	0	2	2	2
Endcap Casting	1	1	1	1	1
Glove Post	6	8	12	14	16
Hanger	3	4	6	7	8
Tent Frame Short Angle	2	2	2	2	2
Tent Frame Long Angle (3-Station Length, 50")	2	0	4	2	0
Tent Frame Long Angle (4-Station Length, 65")	0	2	0	2	4
Tent Frame End Support	2	2	2	2	2
Tent Frame Joining Plate	0	0	2	2	2
Tent	1	1	1	1	1
Caster Kit, Optional	1	1	1	1	1

Notes:

- 1 Blower assembly mount, muffler, and 5th leg assembly may be installed on the blower assembly from the factory.
- 2 Backing plates may be installed on the manifold from the factory.
- 3 Joining plates may be installed on one half of the manifold or tent frame long angles from the factory.

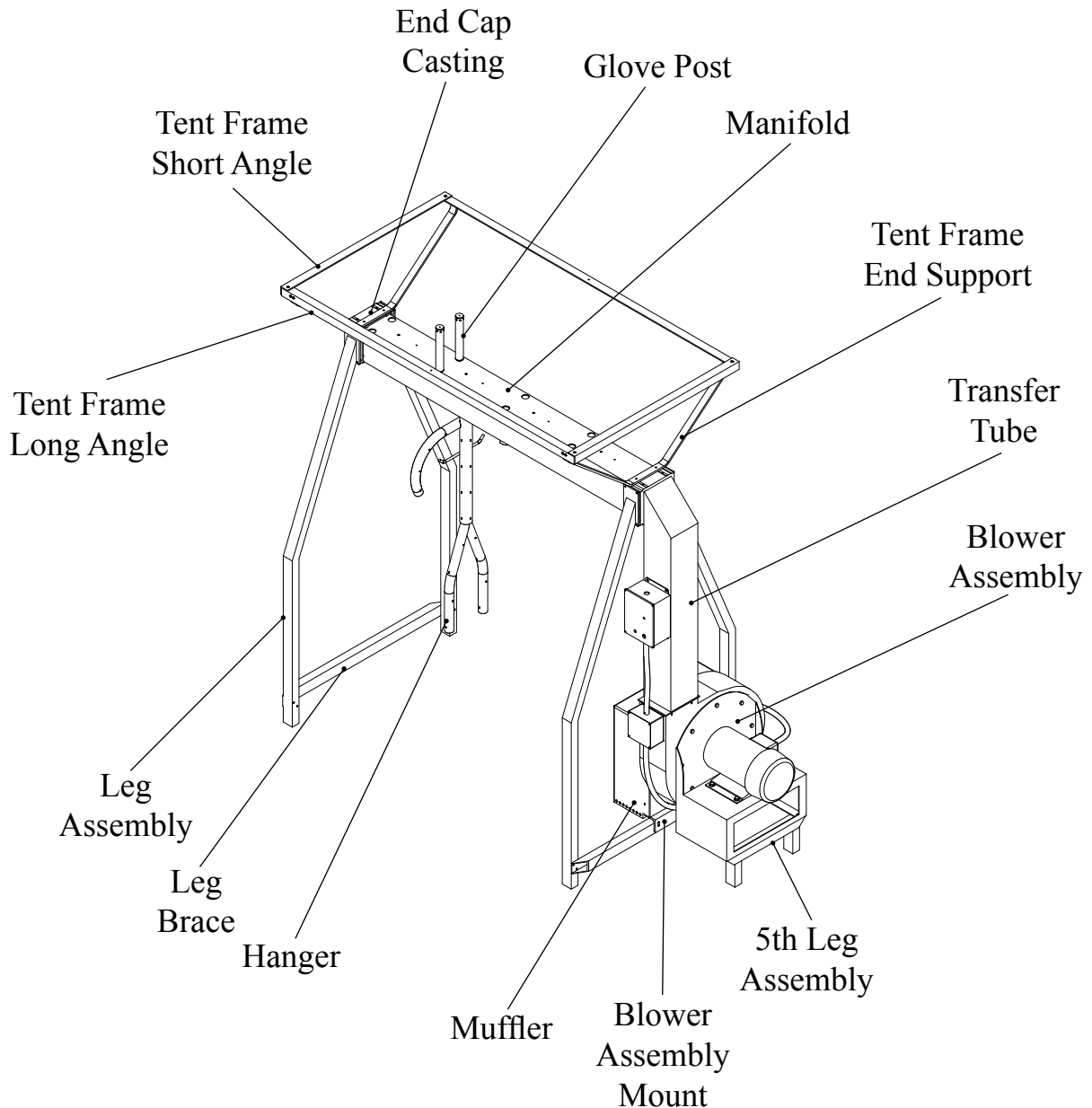

Figure 1. DryGear System Parts

General Notes

- For the 6-station DryGear system two manifolds and two tent frame long angles (50 inches) are put together with joining plates.
- For the 7-station DryGear system there are two different size manifolds and two different size tent frame long angles (50 and 65 inches) put together with joining plates.
- For the 8-station DryGear system two manifolds and two tent frame long angles (65 inches) are put together with joining plates.

Assemble Blower Assembly and Transfer Tube

NOTE: The blower assembly mount may be installed on the blower assembly from the factory.

Parts Needed

- 1-Transfer Tube (1)
- 1-Blower Assembly (3)
- 1-Blower Assembly Mount (4)
- 8-Socket Cap Screw, 1/4-20, 3/4 inch (2)
- 8-Flat Washer, 1/4 inch
- 2-Hex Head Screw, 3/8-16, 1 inch (5)
- 4-Flat Washer, 3/8 inch
- 2-Lock Washer, 3/8 inch
- 2-Nut, 3/8-16

Procedure

1. Install transfer tube (1) on blower assembly (3) with four screws (2) and washers.
2. Install control box (6) on chimney assembly (1) with four screws (2) and washers.

NOTE: The blower assembly mount (4) has two slotted holes that allow for adjustment when the blower assembly (3) is attached to the legs. Ensure that the mount (4) is positioned so that the face with these holes is down and toward the motor side.

3. Install blower assembly mount (4) on blower assembly (3) with two screws (5), washers, and nuts.

End Procedure

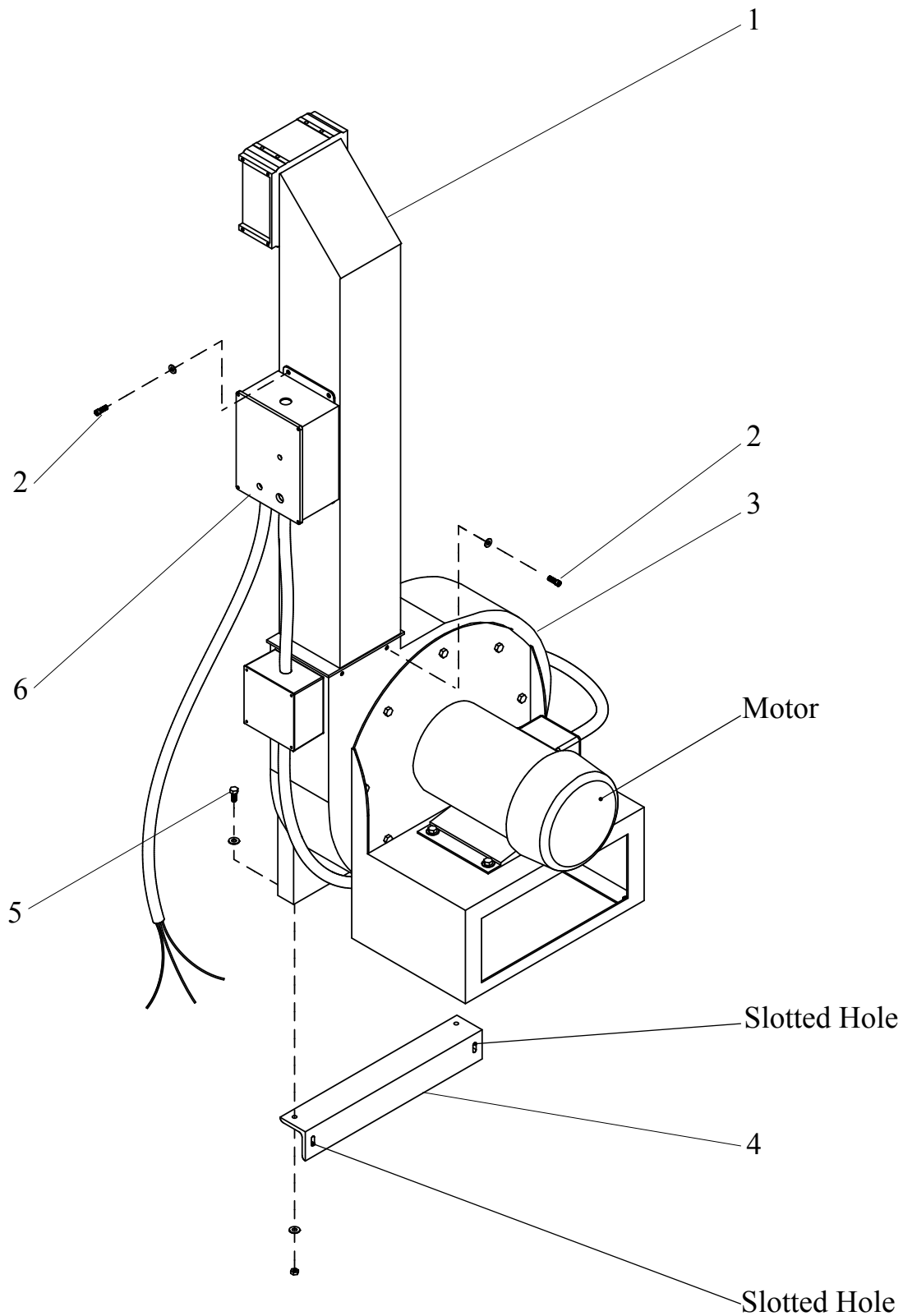

Figure 2. Blower Assembly and Transfer Tube

Assemble Manifolds and Tent Frame Long Angles (6, 7, and 8 Station Only)

NOTE: The joining plates may be installed on one half of the manifold or tent frame long angles from the factory.

Parts Needed

2-Manifold (1)

2-Manifold Joining Plate (3)

4-Tent Frame Long Angle (5)

2-Tent Frame Joining Plate (6)

12-Flat Head Socket Cap Screw, 1/4-20, 1/2 inch (4)

16-Socket Cap Screw, 1/4-20, 3/4 inch (2)

16-Flat Washer, 1/4 inch

Procedure

NOTE: The distance from the end of the manifold to the manifold glove mount holes is different at each end. The glove post holes should be 4 1/4 inches from the manifold end that is attached to the joining plates.

1. Install manifold joining plates (3) between manifolds (1) with sixteen screws (2) and washers.
2. Install tent frame joining plates (6) between tent frame long angles (5) with twelve screws (4).

End Procedure

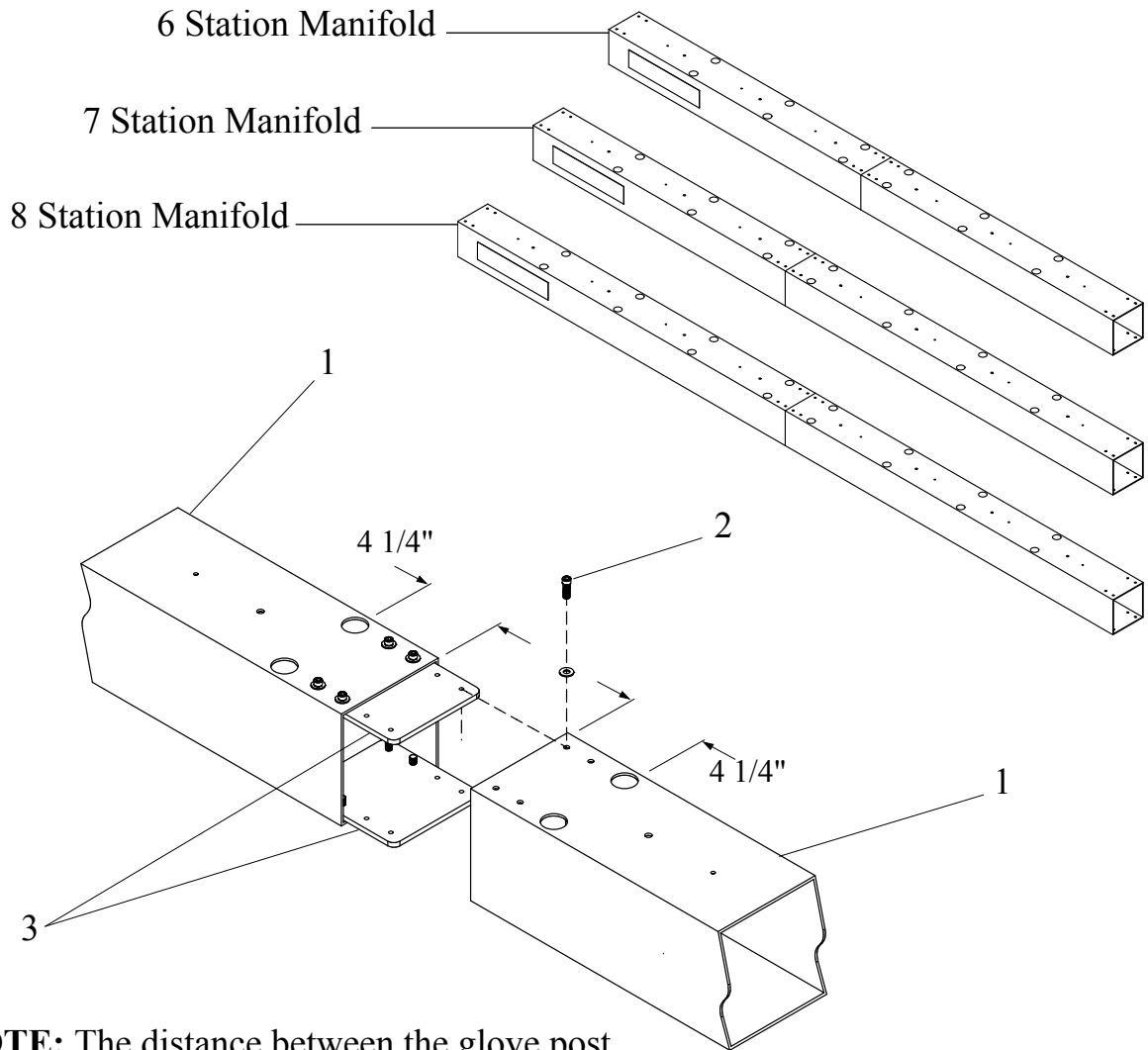

NOTE: The distance between the glove post holes and the correct end of the manifold at the joint plate connection is 4 1/4 inches.

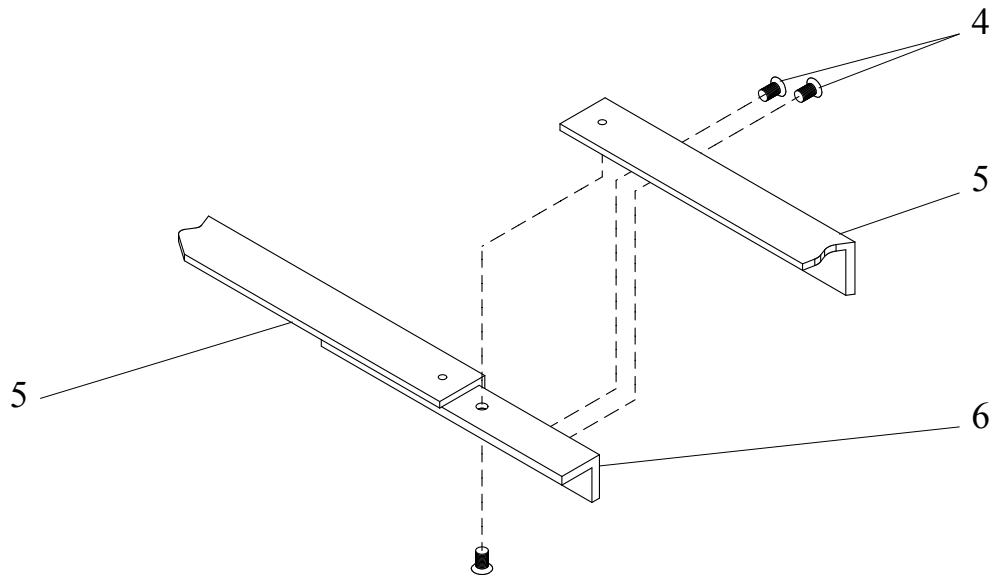

Figure 3. Manifold and Tent Frame Long Angles

Assemble Legs

NOTE: Do not tighten the screws completely until all parts are assembled.

NOTE: For the DRY GEAR Professional with the optional caster kit, make sure the caster threaded leg plugs are installed at this time. (Refer to Install Optional Caster Kit instructions.)

Parts Needed

- 4-Leg Assembly (1)
- 1-Endcap Casting (4)
- 1-Manifold (5)
- 1-Leg Brace, Blower Side (6)
- 1-Leg Brace, Non-Blower Side (8)
- 8-Socket Cap Screw, 1/4-20, 3/4 inch (2)
- 6-Socket Cap Screw, 1/4-20, 1 1/4 inches (3)
- 8-Socket Cap Screw, 1/4-20, 2 1/2 inches (7)
- 8-Nut, 1/4-20
- 26-Flat Washer, 1/4 inch

Procedure

NOTE: The blower side leg brace (6) has two holes for attaching the blower assembly. Ensure that these holes are on the blower side as shown in figure 4.

1. Connect leg braces (6 and 8) between each pair of leg assemblies (1) with eight screws (7), washers, and nuts.

NOTE: The side lower screws that hold the leg assemblies (1) to the endcap casting (4) do not have washers.

2. Connect endcap casting (4) to non-blower side leg assemblies (1) with eight screws (2) and washers.

NOTE: The top inside holes through the endcap casting (4) into the manifold (5) are not used at this time, the holes will be used for mounting the tent frame.

3. Install manifold (5) in endcap casting (4) with six screws (3) and washers.

End Procedure

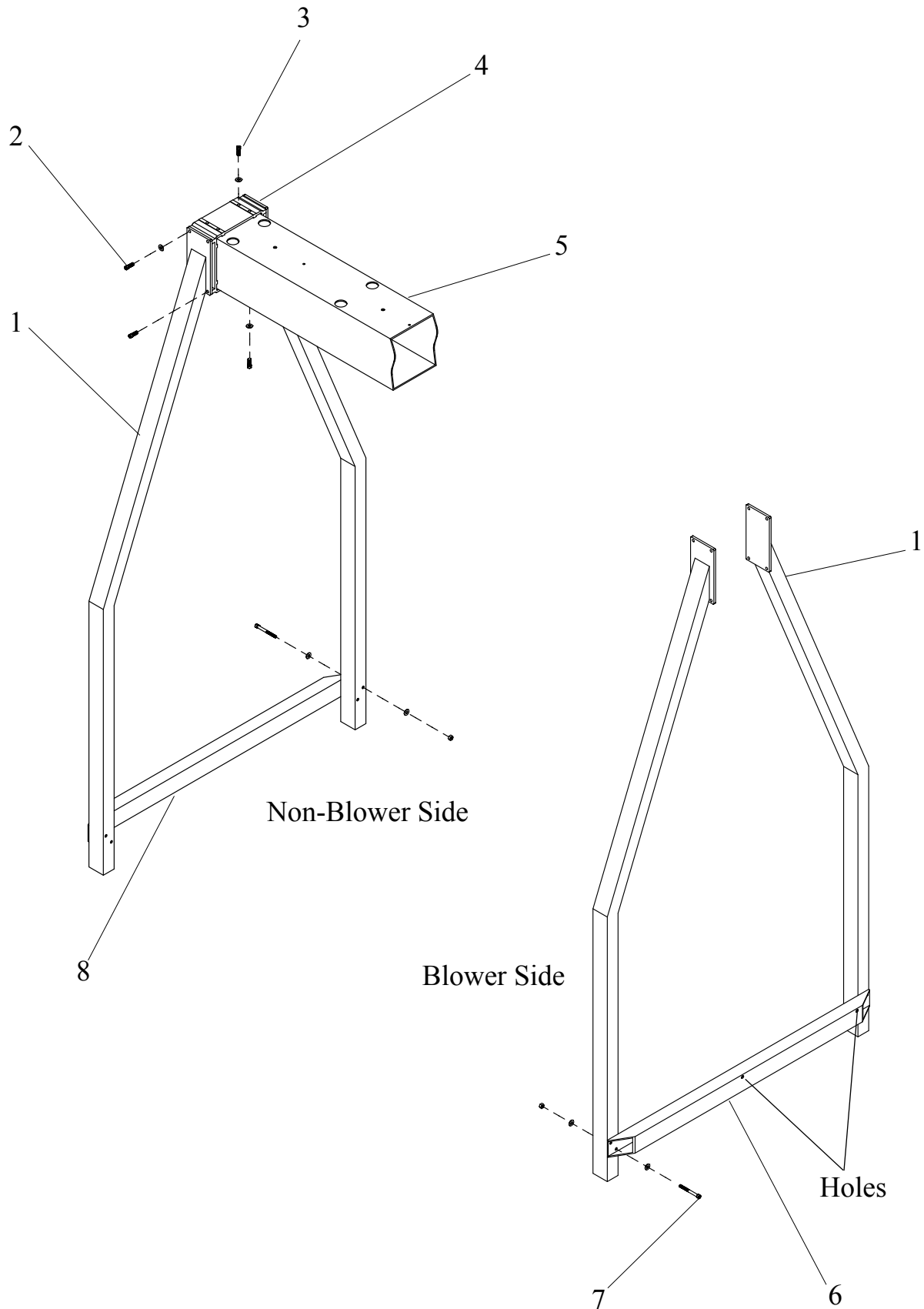

Figure 4. Leg Assemblies

Install Blower Assembly Legs

NOTE : The 5th leg assembly may be installed on the blower assembly from the factory.

Parts Needed

- 1-5th Leg Assembly (3)
- 8-Socket Cap Screw, 1/4-20, 3/4 inch (1)
- 4-Flat Washer, 1/4 inch
- 2-Hex Head Screw, 5/16-18, 2 1/4 inches (4)
- 4-Flat Washer, 5/16 inch
- 2-Nut, 5/16-18
- 2-Hex Head Screw, 3/8-16, 1 inch (2)
- 4-Flat Washer, 3/8 inch
- 2-Nut, 3/8-16

Procedure

NOTE: The side lower screws that hold the blower side legs to transfer tube do not have washers.

1. Connect blower side legs to transfer tube with eight screws (1) and washers. Do not tighten screws.
2. Align blower assembly mount holes with leg brace holes and install two screws (4), washers, and nuts. Do not tighten screws.
3. Tighten blower side legs to transfer tube screws (1).
4. Tighten blower assembly mount screws (4).
5. Install 5th leg assembly (3) with two screws (2), washers, and nuts.

End Procedure

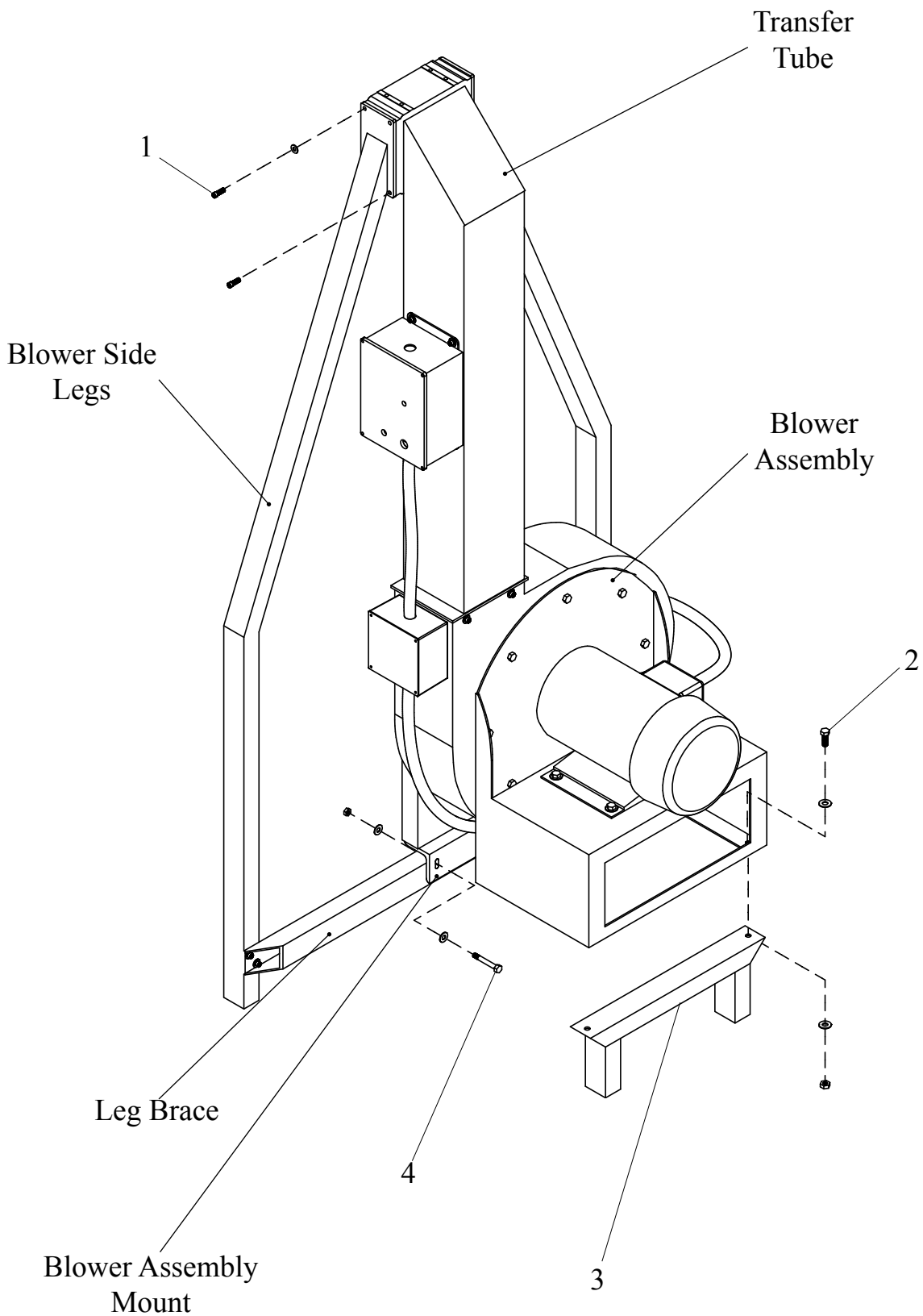

Figure 5. Blower Assembly Legs

Assemble Tent Frame

NOTE: Do not tighten the screws completely until all parts are assembled.

Parts Needed

2-Tent Frame Short Angle (1)

NOTE: For 6, 7, and 8 station configuration pairs of long angles are connected together with a joining plate. (Refer to Assemble Manifold and Tent Frame Long Angles instructions.)

2-Tent Frame Long Angle (2)

2-Tent Frame End Support (3)

12-Flat Head Socket Cap Screw, 1/4-20, 1/2 inch (4)

Procedure

NOTE: For 7 station configuration the 60-inch tent frame long angles are connected to the same end support.

1. Connect two long angles (2) to end supports (3) with eight screws (4).
2. Connect short angles (1) to long angles (2) with four screws (4).

End Procedure

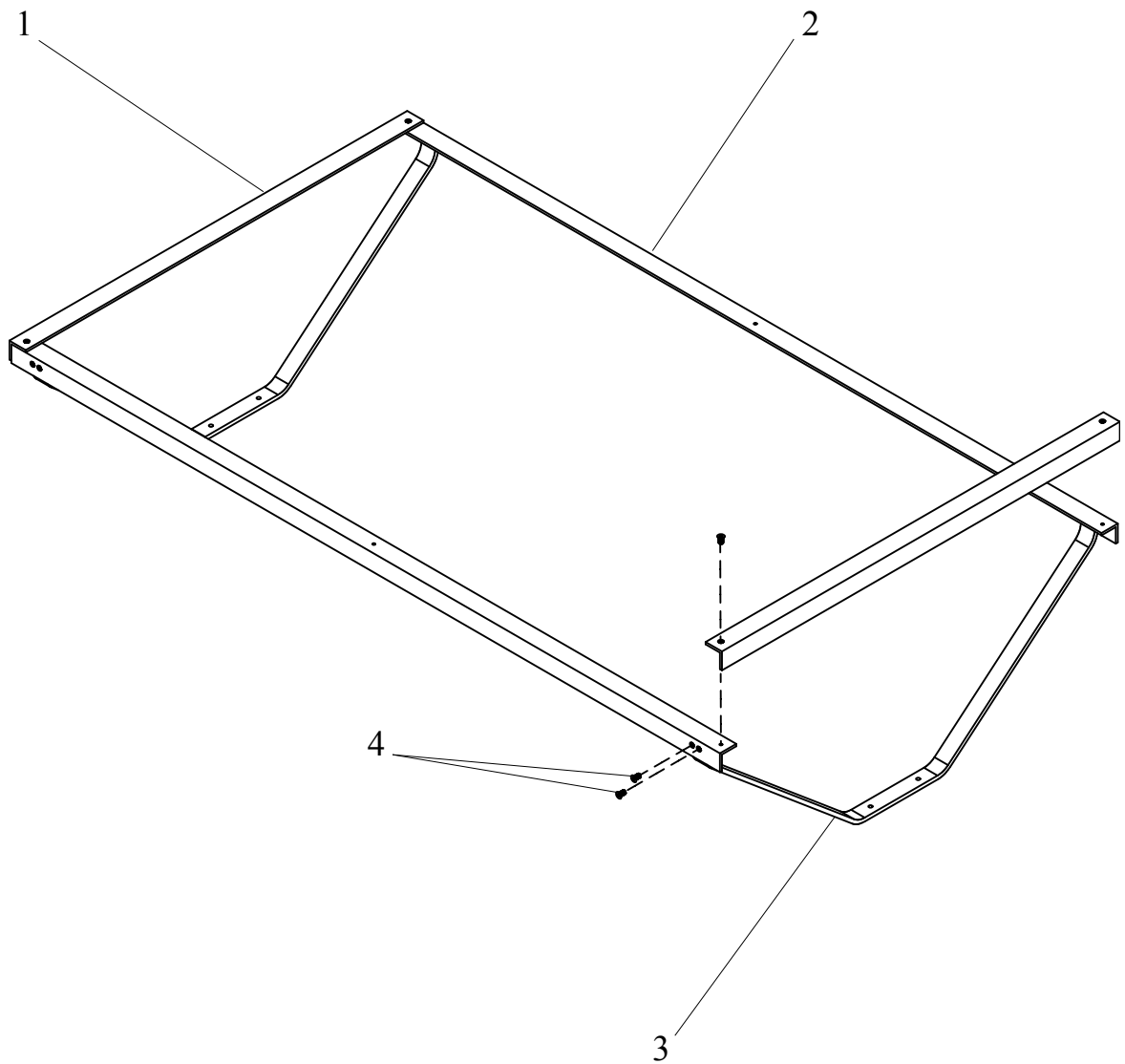

Figure 6. Tent Frame

Assemble Manifold, Tent Frame, and Muffler

NOTE : Muffler may be installed on the blower assembly from the factory.

Parts Needed

1-Muffler (3)

10-Socket Cap Screw, 1/4-20, 1 1/4 inches (1)

4-Socket Cap Screw, 1/4-20, 3/4 inches (2)

14-Flat Washer, 1/4 inch

Procedure

1. Install manifold in transfer tube top with six screws (1) and washers.

NOTE: For 7 station configuration mount the 60-inch tent frame long angle side above the 60-inch manifold side.

2. Install tent frame with four screws (1) and washers.

3. Install muffler (3) on blower with four screws (2) and washers.

End Procedure

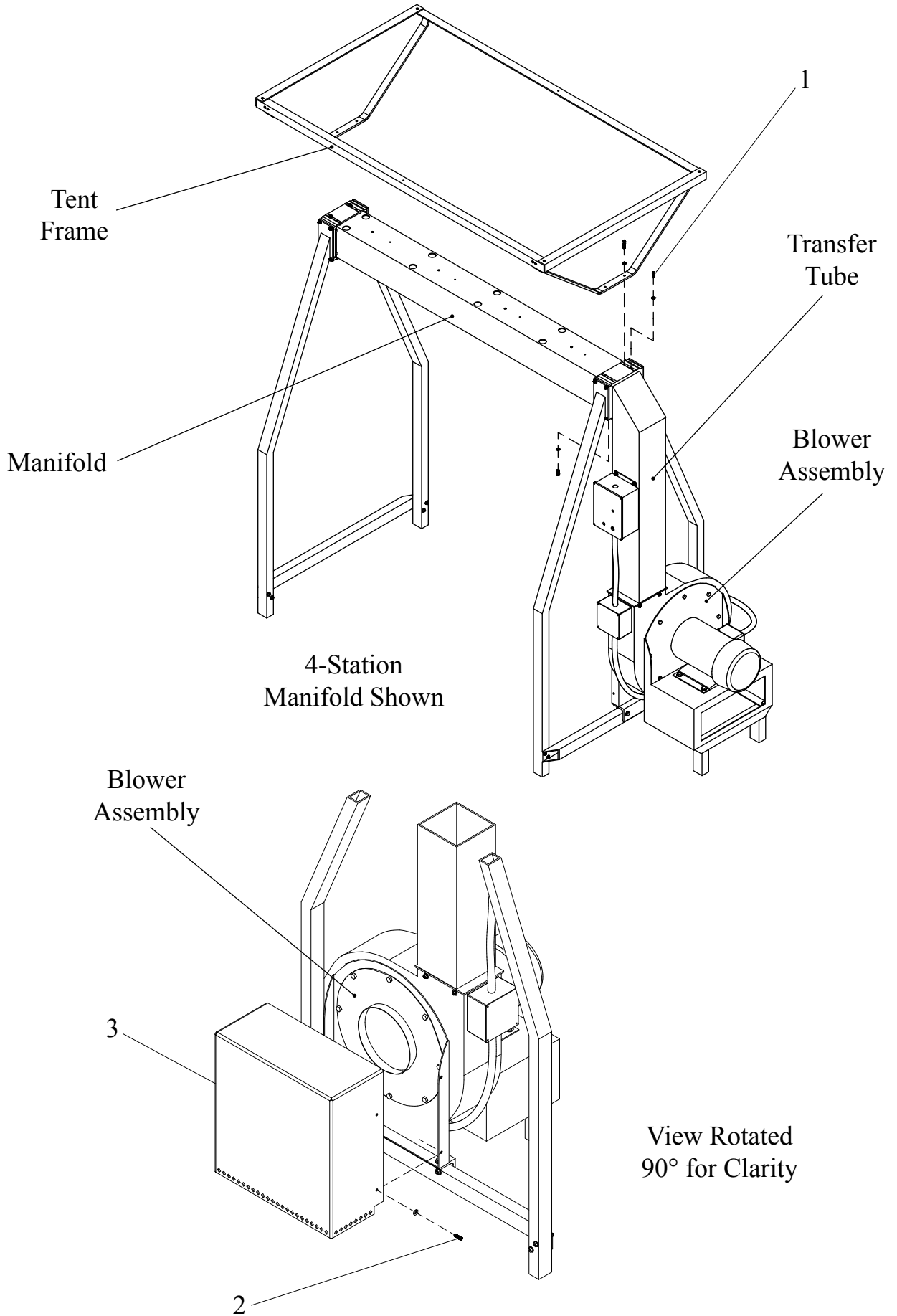

Figure 7. Manifold, Tent Frame, and Muffler

Install Hanger and Glove Post

Parts Needed

NOTE: Quantities shown are for one station.

2-Glove Post (1)

1-Hanger (3)

1-Hex Head Screw, 5/16-18, 3/4 inch (2)

1-Flat Washer, 5/16 inch

1-Lock Washer, 5/16 inch

Procedure

NOTE: Make sure the hanger manifold air opening is towards the blower assembly end of the manifold.

1. Slide hanger (3) into hole in bottom of manifold with hanger manifold air opening towards the blower. Attach to top of manifold with screw (2) and washers. The removable hanger (3a and 3b) installs the same way.
2. Screw glove post assembly (1) into top of manifold.

End Procedure

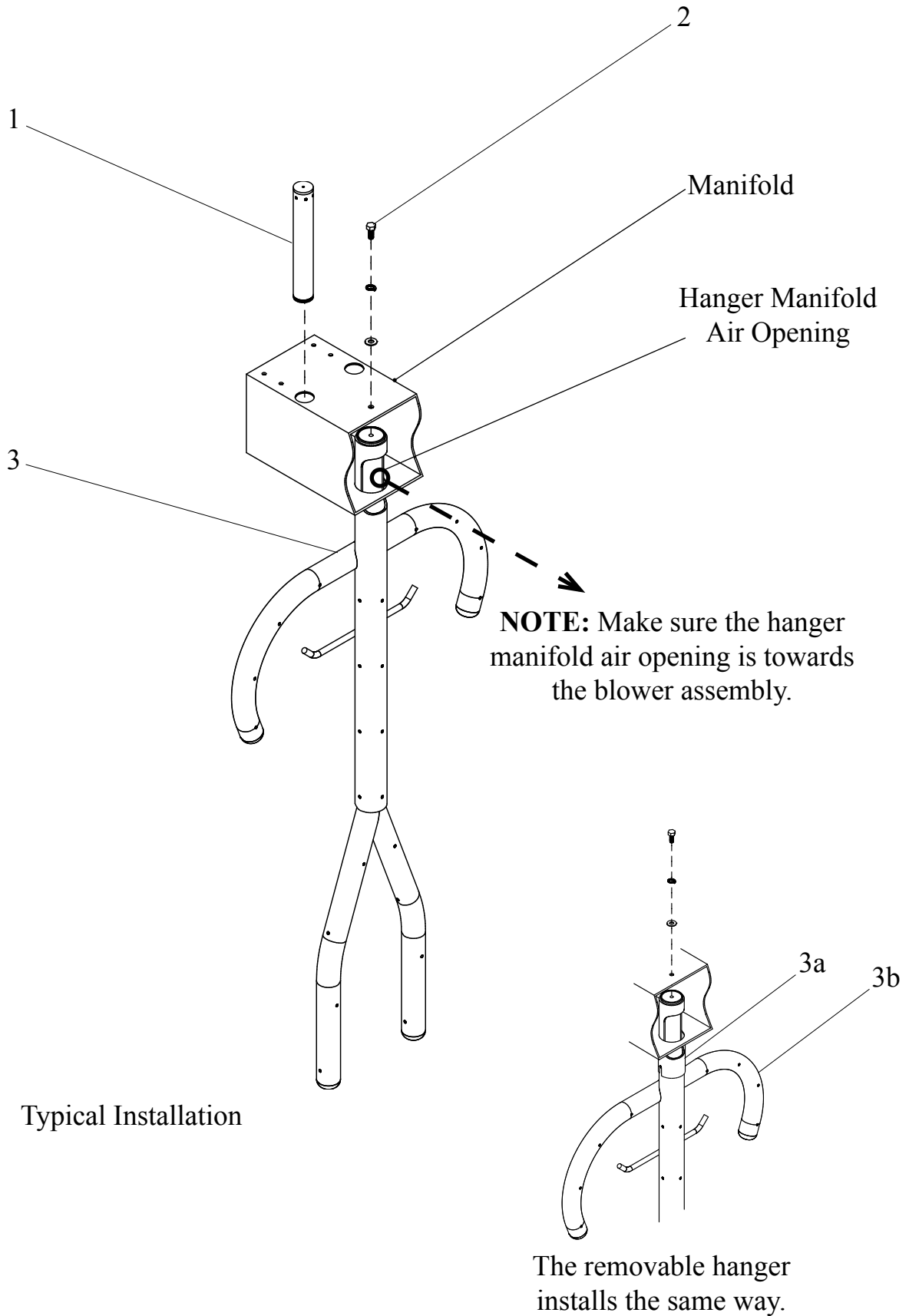

Figure 8. Hanger and Glove Post

Install Tent Enclosure

NOTE: The tent for the 6, 7, and 8 station configurations comes in two halves with a zipper in the middle. The following procedure is to install the right half, the left half is a mirror image.

Parts Needed

1-Tent

Procedure

1. Place tent over tent frame and square up top.
2. Ensure that the tent frame long angle supports the nylon web between the outer and inner D-rings. Loop the nylon web around the rear tent frame long angle and secure with Velcro.
3. Pull tent sides down and secure around chimney, blower assembly and legs with Velcro. For the 6, 7, and 8 station configurations the left side is a mirror image, zip up the left and right halves.

NOTE: There are two different length cords provided. The shorter cord attaches to the inner D-ring closest to the Velcro strap.

4. Connect cord clips to inner D-rings.
5. Drop cord ends down under tube and up through the inside of outer D-rings.
6. Tie a knot to secure cord ends together.
7. Pull cords.

Result: Front cover rolls up on tube.

8. Secure cord in position with Velcro strap.

End Procedure

NOTE: The tent for the 6, 7, and 8 station configurations comes in two halves with a zipper in the middle. *This drawing shows a center zipper, and this is only for the 6, 7, and 8 station configurations.*

One side of the zipper track tape is missing teeth, this is to start the slider. Guide the track tape into the groove of the slider making sure it is evenly seated on the track. Carefully pull the slider up until the locked track teeth appear at the bottom

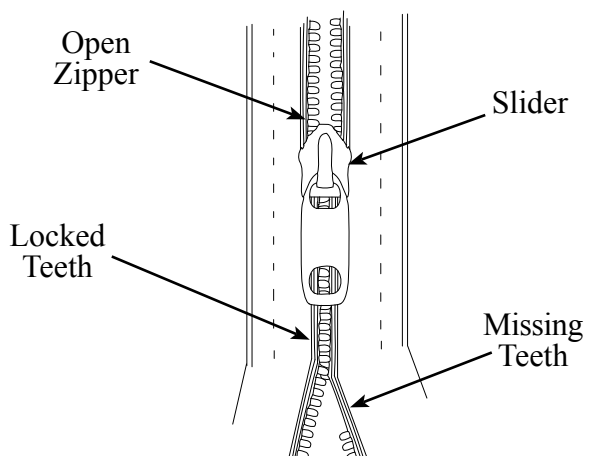

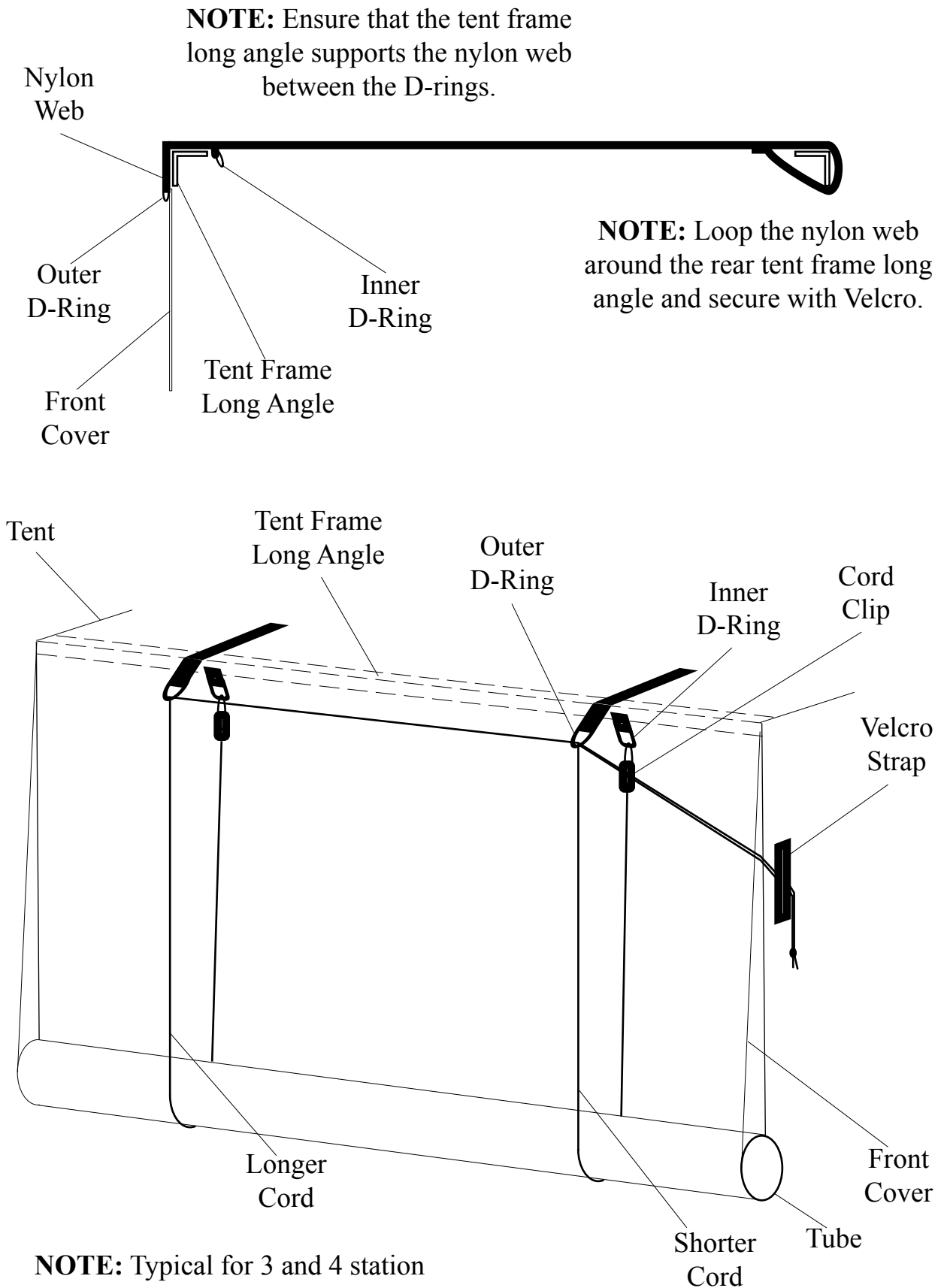

Figure 9. Tent Enclosure

Install Optional Caster Kit

The caster kit option adds 3 3/4 inches to the height of the DryGear.

Parts Needed

1-Caster Kit

NOTE: The caster kit includes six threaded leg plugs and six casters, two casters have a break mechanism.

Procedure

NOTE: The caster threaded leg plugs may be installed in the leg assemblies at the factory.

1. Remove plastic leg plugs from leg assemblies.
2. Install threaded plugs in leg assemblies. Tap plug lightly to seat completely into leg.

NOTE: Two casters have a brake mechanism, these should be installed on the front legs.

3. Screw casters into threaded plugs.

End Procedure

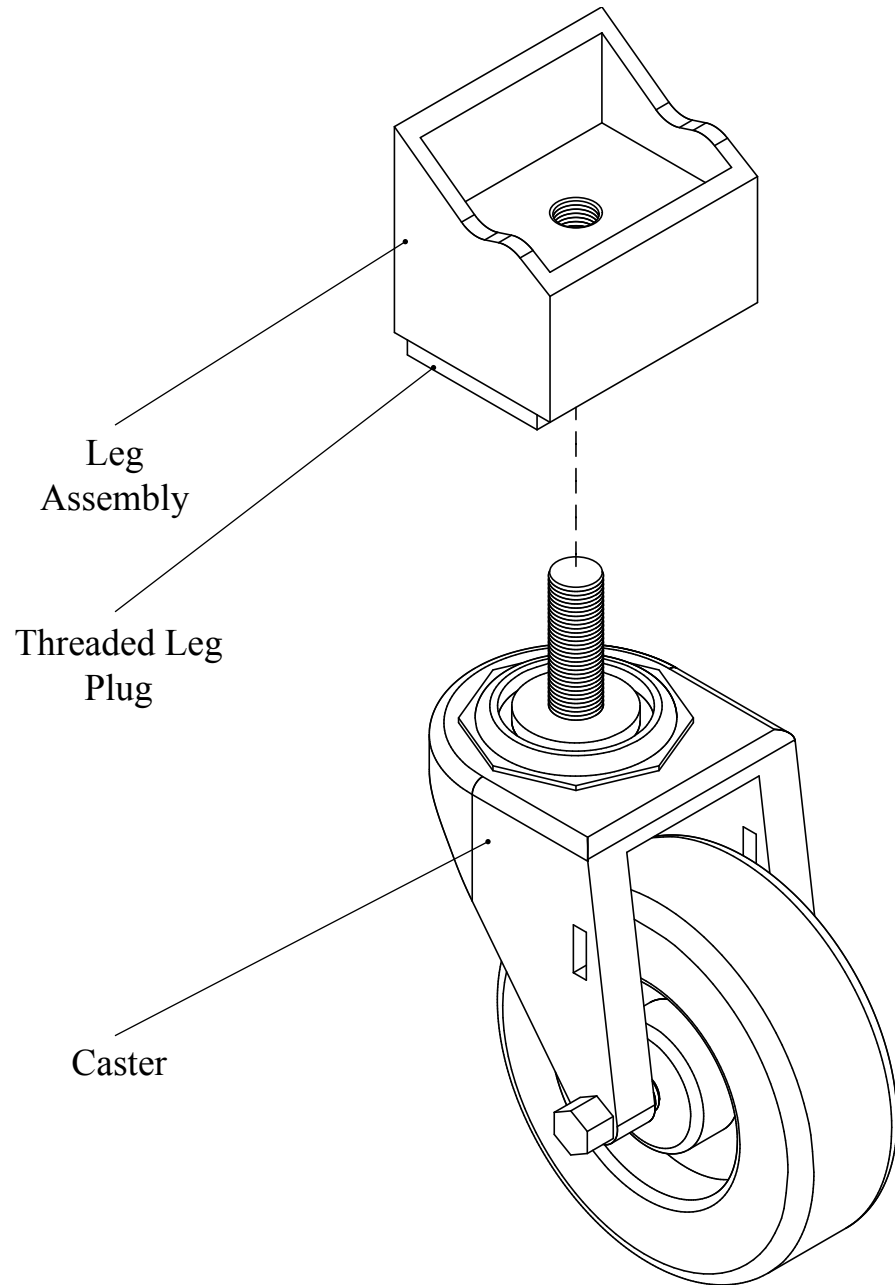

Figure 10. Caster Kit

WIRING POWER

WARNING: High Voltage. This product must be wired in accordance with the National Electrical Code (NEC) and applicable local codes and ordinances. Failure to comply could result in injury to personnel.

NOTE: Only a licensed electrician should install the power cable.

Procedure

1. Remove four screws and swing control box front panel to the right (internal wires will support the panel). Do not remove wiring to the controls.

NOTE: There are two 3/4 inch access holes in the control box. The power cable is installed through either the top or bottom hole.

2. Install strain relief for power cable in one of the two access holes.
3. Install three conductor 10 AWG power cable through strain relief and access hole.
3. Connect power cable wires to input power terminal block **L1**, **L2**, and **GROUND**.
4. Install control box panel with four screws.
5. Set **BLOWER & HEATER HOURS** switch to **OFF** position.
6. Connect the power cable to 220 volt, 30 amp service.

End Procedure

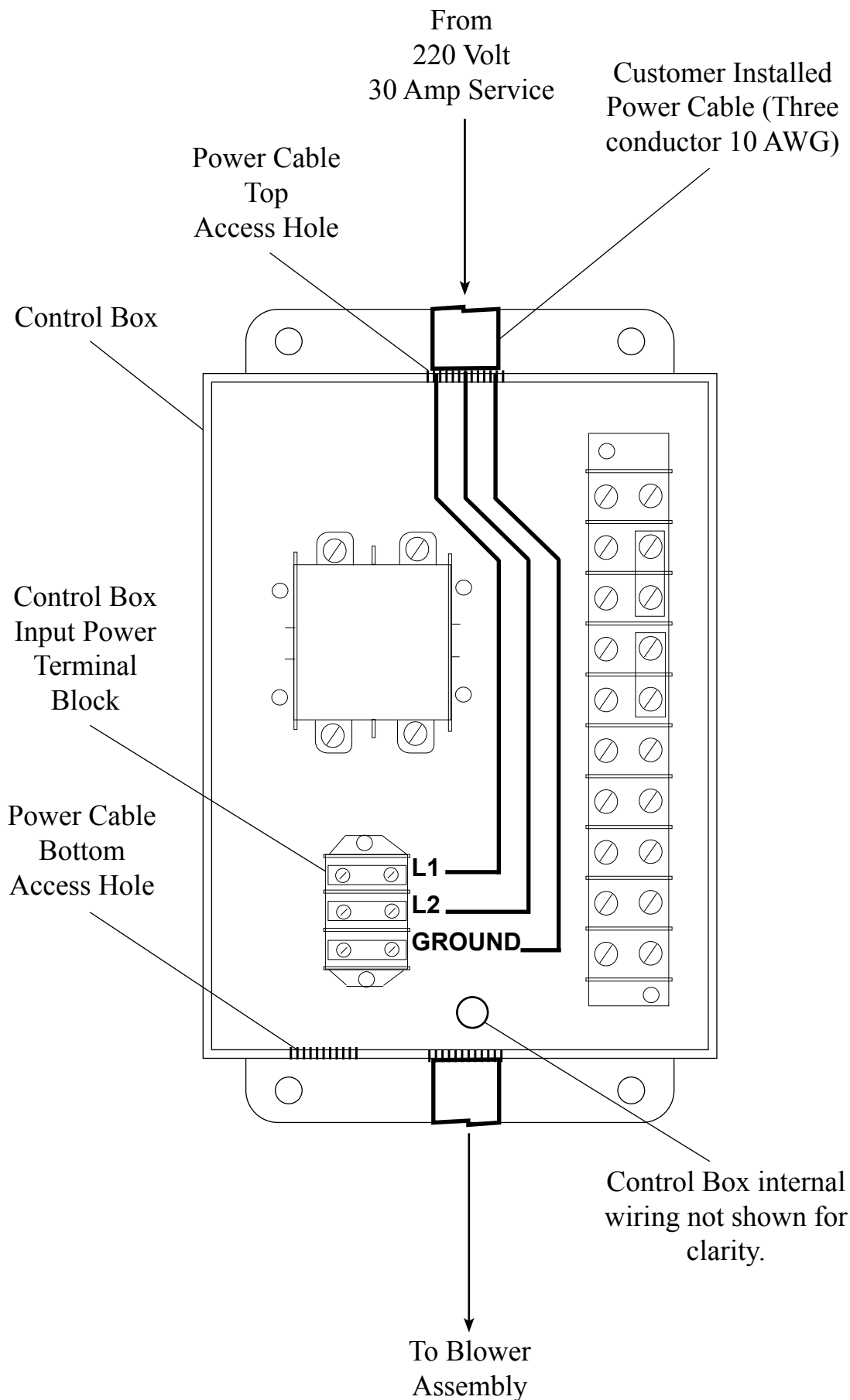

Figure 11. Wiring Power

OPERATION

The DryGear system blower operates independently from the heater and can be powered alone to circulate room temperature air.

Overheat Protection

The heater can not be powered without the blower running, this is to prevent the heater from overheating. An internal thermistor cuts power to the heater and blower if the heater temperature rises above 180 °F. The heater and blower power is back on when the heater temperature falls below 150 °F.

Procedure

Hang coat and pants on hanger assembly, put gloves over glove posts, helmets and hoods may be set on top of the manifold, boots and other equipment may be placed inside the enclosure.

Remove the hanger assemblies (DryGear Plus only) to roll in racks of hose or loose equipment.

1. Place SELECT switch to AIR ONLY position.

NOTE: If the timer is to be set for less than one hour the timer switch must be turned clockwise past 1 and then back to desired time.

2. Set BLOWER & HEATER HOURS switch to desired time.

Result: The blower goes on. Room temperature air is circulated in the DryGear enclosure.

3. Place SELECT switch to AIR & HEAT position.

Result: The HEATER SELECTED lamp goes on. Heated air is circulated in the DryGear enclosure.

4. Close the tent front cover and zip up the sides (zip up the center on 6, 7, and 8 station configurations).

NOTE: Some air will escape from the bottom of the enclosure to disperse moisture. Do not attempt to make an air tight seal to the floor.

End Procedure

NOTE: For less than one hour of operation rotate **BLOWER & HEATER HOURS** switch past 1 then back to desired time.

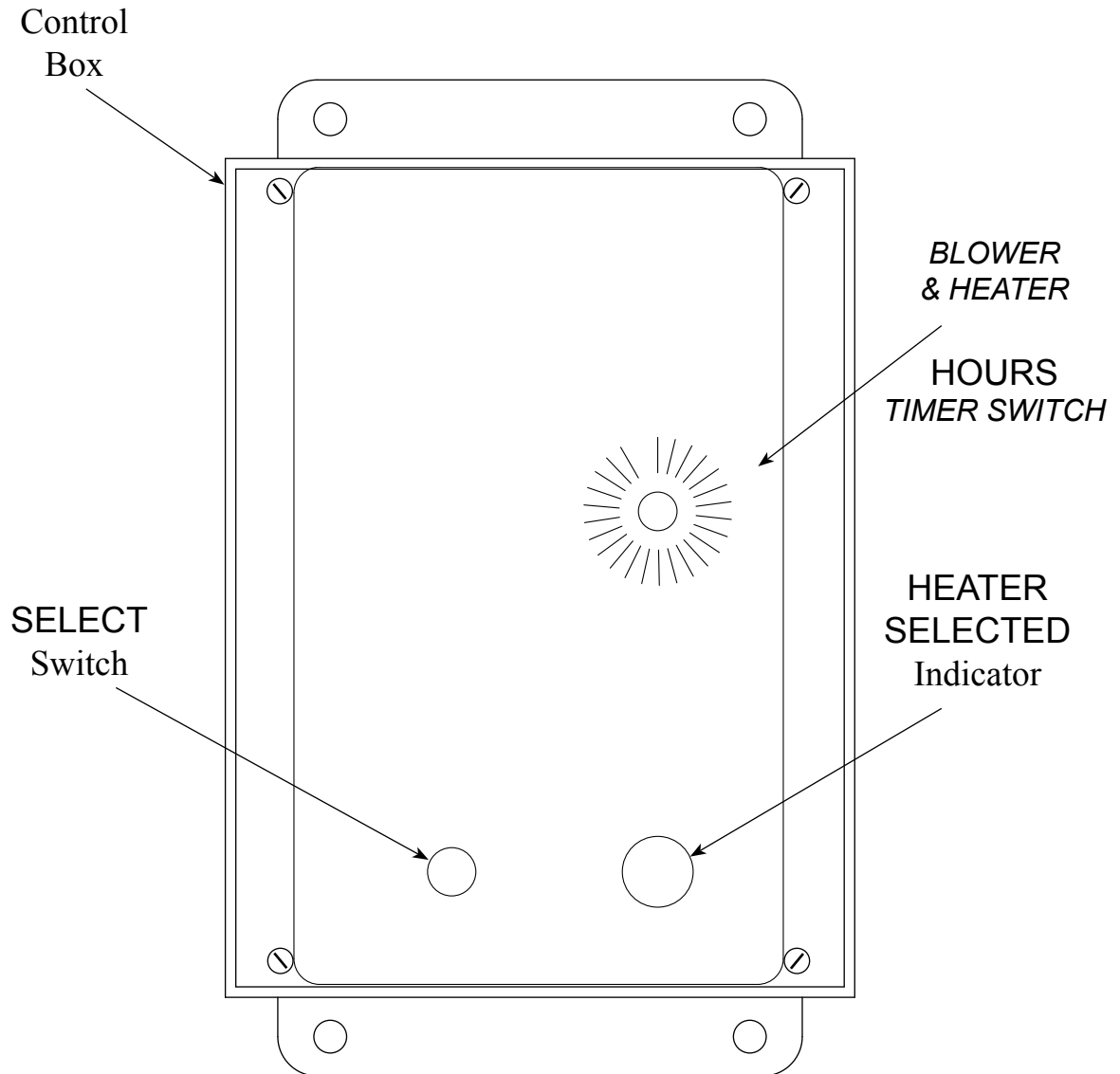

Figure 12. Control Box Panel

NOTES

NOTES



PERSONAL RESPONSIBILITY CODE

The member companies of FEMSA that provide emergency response equipment and services want responders to know and understand the following:

1. Firefighting and Emergency Response are inherently dangerous activities requiring proper training in their hazards and the use of extreme caution at all times.
2. It is your responsibility to read and understand any user's instructions, including purpose and limitations, provided with any piece of equipment you may be called upon to use.
3. It is your responsibility to know that you have been properly trained in Firefighting and/or Emergency Response and in the use, precautions, and care of any equipment you may be called upon to use.
4. It is your responsibility to be in proper physical condition and to maintain the personal skill level required to operate any equipment you may be called upon to use.
5. It is your responsibility to know that your equipment is in operable condition and has been maintained in accordance with the manufacturer's instructions.
6. Failure to follow these guidelines may result in death, burns or other severe injury.



Fire and Emergency Manufacturers and Services Association, Inc.
P.O. Box 147, Lynnfield, MA 01940 www.FEMSA.org

Copyright 2006 FEMSA. All Rights Reserved