

# WHELEN<sup>®</sup>

ENGINEERING COMPANY INC.

51 Winthrop Road  
Chester, Connecticut 06412-0684  
Phone: (860) 526-9504  
Fax: (860) 526-4078  
Internet: [www.whelen.com](http://www.whelen.com)  
Sales e-mail: [autosale@whelen.com](mailto:autosale@whelen.com)  
Canadian Sales e-mail: [autocan@whelen.com](mailto:autocan@whelen.com)  
Customer Service e-mail: [custserv@whelen.com](mailto:custserv@whelen.com)

## Installation Guide: Pioneer™-series LED Floodlight Brow Mount

### Safety First

This document provides all the necessary information to allow your Whelen product to be properly and safely installed. Before beginning the installation and/or operation of your new product, the installation technician and operator must read this manual completely. Important information is contained herein that could prevent serious injury or damage.

- **Proper installation of this product requires the installer to have a good understanding of automotive electronics, systems and procedures.**
- **If mounting this product requires drilling holes, the installer MUST be sure that no vehicle components or other vital parts could be damaged by the drilling process. Check both sides of the mounting surface before drilling begins. Also de-burr any holes and remove any metal shards or remnants. Install grommets into all wire passage holes.**
- **If this manual states that this product may be mounted with suction cups, magnets, tape or Velcro™, clean the mounting surface with a 50/50 mix of isopropyl alcohol and water and dry thoroughly.**
- **Do not install this product or route any wires in the deployment area of your air bag. Equipment mounted or located in the air bag deployment area will damage or reduce the effectiveness of the air bag, or become a projectile that could cause serious personal injury or death. Refer to your vehicle owners manual for the air bag deployment area. The User/Installer assumes full responsibility to determine proper mounting location, based on providing ultimate safety to all passengers inside the vehicle.**
- **For this product to operate at optimum efficiency, a good electrical connection to chassis ground must be made. The recommended procedure requires the product ground wire to be connected directly to the NEGATIVE (-) battery post.**
- **If this product uses a remote device to activate or control this product, make sure that this control is located in an area that allows both the vehicle and the control to be operated safely in any driving condition.**
- **Do not attempt to activate or control this device in a hazardous driving situation.**
- **This product contains either strobe light(s), halogen light(s), high-intensity LEDs or a combination of these lights. Do not stare directly into these lights. Momentary blindness and/or eye damage could result.**
- **Use only soap and water to clean the outer lens. Use of other chemicals could result in premature lens cracking (crazing) and discoloration. Lenses in this condition have significantly reduced effectiveness and should be replaced immediately. Inspect and operate this product regularly to confirm its proper operation and mounting condition. Do not use a pressure washer to clean this product.**
- **It is recommended that these instructions be stored in a safe place and referred to when performing maintenance and/or reinstallation of this product.**
- **FAILURE TO FOLLOW THESE SAFETY PRECAUTIONS AND INSTRUCTIONS COULD RESULT IN DAMAGE TO THE PRODUCT OR VEHICLE AND/OR SERIOUS INJURY TO YOU AND YOUR PASSENGERS!**

**For warranty information regarding this product, visit [www.whelen.com/warranty](http://www.whelen.com/warranty)**

**Mounting...**

**Tools Required -**

1/8, 7/16, 1/4 Allen Wrench 17/32 (.531) Drill Bit Rivnut™ Installation Tool  
Torque Wrench (in./lbs.) LocTite® 242® Threadlocker or equivalent product

**IMPORTANT! Permanent mounting of this product will require drilling. It is absolutely necessary to make sure that no other vehicle components could be damaged by this process. Check both sides of the mounting surface before starting. If damage is likely, select a different mounting location.**

1. Insert the Floodlight Brackets (Item #8) into the floodlight extrusion as shown. Secure these brackets to the extrusion using the hardware provided (#9).
2. Using the appropriate hardware (Items #1, #2 & #3), install the Adjustable Mounting Brackets (Items #4 & #10) onto the Floodlight Brackets.
3. Position the Floodlight/Mounting Bracket assembly onto its proposed mounting location. Make sure that the mounting brackets fit properly onto the mounting surface.
4. When the best location has been determined, Carefully mark the areas where the mounting holes are to be drilled. Remove the assembly from the mounting area.

**IMPORTANT NOTE! This installation uses Rivnuts™ to secure the brackets to the vehicle. This type of hardware requires the use of a specialized installation tool. Refer to the owners manual included with this tool for proper installation techniques. Be sure to follow the mounting hole specifications precisely!**

5. With the Rivnuts™ properly installed, the floodlight can now be mounted onto the vehicle using the appropriate hardware (Items #5, #6 & #7). Insert the bolts into their holes in the mounting bracket and install a rubber washer (Item #6) onto each bolt.
6. Apply a drop of LocTite® 242® to each of the four mounting bolts and insert them into their Rivnut™. Tighten each bolt to 50 in/lbs.

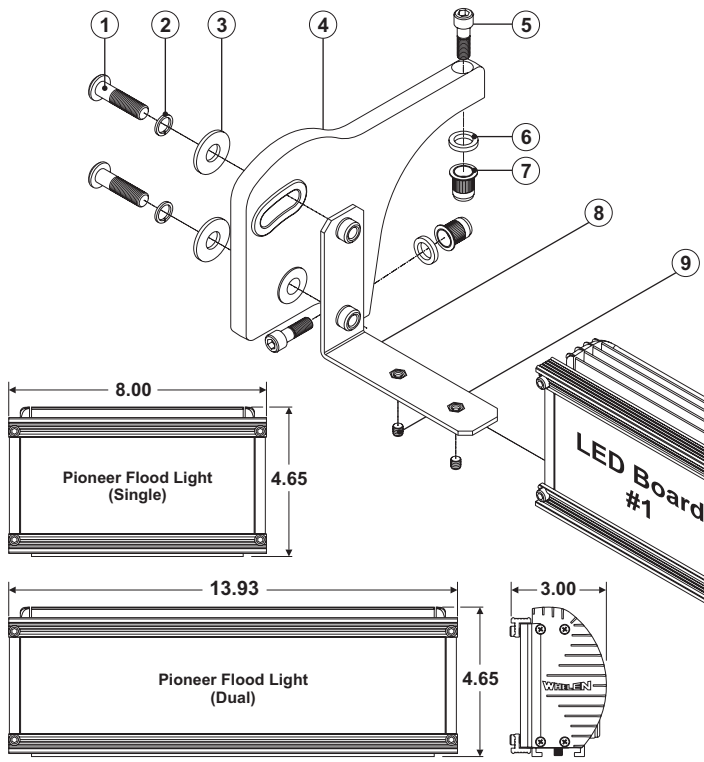

PART NUMBER		DESCRIPTION	
01-0686136-00		Pioneer-series LED Floodlight (Single)	
01-0686054-00		Pioneer-series LED Floodlight (Dual)	
QTY	ITEM	PART NUMBER	DESCRIPTION
		01-0486048-00	Pioneer Mounting Kit - Brow Mount
4	1	14-156B36-240	SOC. BUTTON HEAD SCREW, 3/8-16 X 1 1/2 S.S.
4	2	16-1532220-10	3/8 WASHER SPLIT-LOK S.S.
4	3	16-1503220-60	3/8 FLAT WASHER-S.S.
1	4	07-286048-001	ADJUSTABLE MOUNTING BRACKET, DRIVER SIDE
4	5	14-148A26-160	SCREW, 5/16-18 X 1 SOC HD CAP SCR.-S.S.
4	6	16-0017882-00	WASHER,RUBBER
4	7	13-148F18-000	RIVNUT 5/16-18
2	8	07-243735-000	LIGHT BRACKET FLOOD LIGHT
4	9	14-130526-040	SCREW, 1/4-20 X 1/4 SOCKET SET-S.S.
1	10	07-286049-001	ADJUSTABLE MOUNTING BRACKET, PASS.SIDE

**Wiring...**

**All customer supplied wires that connect to the positive terminal of the battery must be sized to supply at least 125% of the maximum operating current and FUSED at the battery to carry that load. DO NOT USE CIRCUIT BREAKERS WITH THIS PRODUCT!**

**Pioneer Single...**

1. Extend the RED wire to the customer supplied SP/ST switch. This switch must be capable of accommodating a 3 Amp circuit. From the switch, extend an appropriately sized wire to the POS battery terminal. Fuse this wire @ 5 Amps (customer supplied).
2. Extend the BLACK wire to chassis Ground

**Pioneer Dual...**

1. Extend the WHT wire to the customer supplied SP/ST switch designated to control LED Board #1. This switch must be capable of accommodating a 3 Amp circuit. From the switch, extend an appropriately sized wire to the POS battery terminal. Fuse this wire @ 5 Amps (customer supplied).
2. Extend the RED wire to the customer supplied SP/ST switch designated to control LED Board #2. This switch must be capable of accommodating a 3 Amp circuit. From the switch, extend an appropriately sized wire to the POS battery terminal. Fuse this wire @ 5 Amps (customer supplied).
3. Extend and connect the BLK and GRN wires to chassis ground.

NOTE: If the user chooses, a single switch of sufficient capacity may be used to activate both LED boards simultaneously. If wired as such, a 10 Amp fuse must be used in place of the two 5 Amp fuses specified above.

**IMPORTANT! Before returning the vehicle to active service, visually confirm the proper operation of this product, as well as all vehicle components/equipment.**

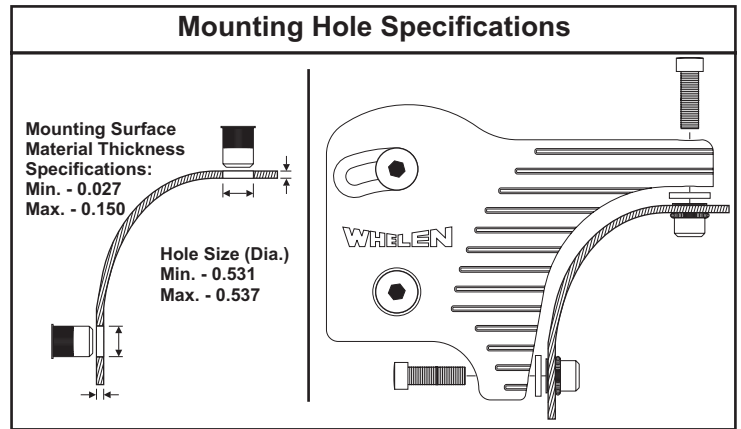

Pioneer Dual Shown For Reference Only

**Wiring: Pioneer Single**  
RED - +12VDC (Fuse@5A)  
BLK - GROUND

**Wiring: Pioneer Dual**  
WHT - LED Board #1 / +12VDC (Fuse@5A)  
BLK - LED Board #1 / GROUND  
RED - LED Board #2 / +12VDC (Fuse@5A)  
GRN - LED Board #2 / GROUND

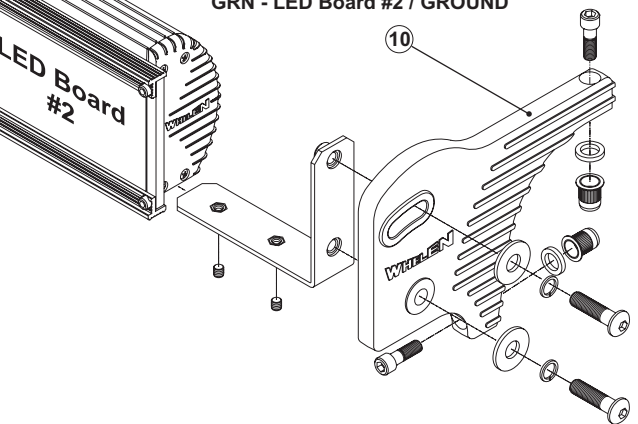

**Specifications**

Product Type . . . . . LED Flood Light  
LED Boards . . . . . 1 (Pioneer Single) or 2 (Pioneer Dual)  
Input Voltage (per board) . . 12.8 VDC±20%  
Input Current (per board) . . 3 Amps  
Lumens (per board) . . . . . 2500  
Duty Cycle . . . . . 100%