

WHELEN[®]

ENGINEERING COMPANY INC.

Route 145, Winthrop Road,
Chester, Connecticut 06412

Phone: (860) 526-9504

Fax: (860) 526-4078

Internet: www.whelen.com

Sales e-mail: autosale@whelen.com

Canadian Sales e-mail: autocan@whelen.com

Customer Service e-mail: custserv@whelen.com

Installation Guide: Freedom Mini Edge[®] NFPA Lightbar

Safety First

This document provides all the necessary information to allow your Whelen product to be properly and safely installed. Before beginning the installation and/or operation of your new product, the installation technician and operator must read this manual completely. Important information is contained herein that could prevent serious injury or damage.

- Proper installation of this product requires the installer to have a good understanding of automotive electronics, systems and procedures.
- If mounting this product requires drilling holes, the installer **MUST** be sure that no vehicle components or other vital parts could be damaged by the drilling process. Check both sides of the mounting surface before drilling begins. Also de-burr any holes and remove any metal shards or remnants. Install grommets into all wire passage holes.
- If this manual states that this product may be mounted with suction cups, magnets, tape or Velcro[™], clean the mounting surface with a 50/50 mix of isopropyl alcohol and water and dry thoroughly.
- Do not install this product or route any wires in the deployment area of your air bag. Equipment mounted or located in the air bag deployment area will damage or reduce the effectiveness of the air bag, or become a projectile that could cause serious personal injury or death. Refer to your vehicle owners manual for the air bag deployment area. The User/Installer assumes full responsibility to determine proper mounting location, based on providing ultimate safety to all passengers inside the vehicle.
- For this product to operate at optimum efficiency, a good electrical connection to chassis ground must be made. The recommended procedure requires the product ground wire to be connected directly to the **NEGATIVE (-)** battery post.
- If this product uses a remote device to activate or control this product, make sure that this control is located in an area that allows both the vehicle and the control to be operated safely in any driving condition.
- Do not attempt to activate or control this device in a hazardous driving situation.
- This product contains either strobe light(s), halogen light(s), high-intensity LEDs or a combination of these lights. Do not stare directly into these lights. Momentary blindness and/or eye damage could result.
- Use only soap and water to clean the outer lens. Use of other chemicals could result in premature lens cracking (crazing) and discoloration. Lenses in this condition have significantly reduced effectiveness and should be replaced immediately. Inspect and operate this product regularly to confirm its proper operation and mounting condition. Do not use a pressure washer to clean this product.
- It is recommended that these instructions be stored in a safe place and referred to when performing maintenance and/or reinstallation of this product.
- **FAILURE TO FOLLOW THESE SAFETY PRECAUTIONS AND INSTRUCTIONS COULD RESULT IN DAMAGE TO THE PRODUCT OR VEHICLE AND/OR SERIOUS INJURY TO YOU AND YOUR PASSENGERS!**

For warranty information regarding this product, visit www.whelen.com/warranty

Permanent Mounting:

1. Locate the mounting foot and mounting plate included with your lightbar. If not already present, install the mounting plate onto the mounting foot. When properly positioned, this plate is centered from side to side on the mounting foot.
2. Flip the lightbar upside-down to expose the bottom of the extrusion and place the mounting foot onto the extrusion.
3. Rotate the mounting foot 90° in a counter-clockwise direction. Make sure that the edges of the mounting foot swing into position under the extrusion mounting lip.
4. Repeat this procedure for the remaining mounting foot and return the lightbar to its right side-up position.
5. Position the lightbar onto the vehicle roof in the desired mounting location. One often selected location is directly above the B-pillars. This area is the strongest part of the roof. Refer to your lightbar manual for cable exit location, to be sure that the lightbar is facing the proper direction.
6. Adjust the two mounting feet outwards so that they are as close to the edge of the roof as possible. Make sure that both mounting feet are in full contact with the roof. Be sure that there is no less than 1/2" clearance between the roof and the lightbar at their closest point. When the mounting feet are in their proper position, lightly tighten the mounting foot allen head set screws.
7. Turn the lightbar upside down and firmly tighten all of the set screws from step 6 (2 or 4 per side).
8. On the mounting foot, remove either the two outer or inner rubber mounting pads. Carefully remove the mounting pad's guide dart so the hole through the center of the pad is exposed then replace the pad (Standard foot only). On the adjustable foot, use the hole in the pad as a guide to drill the two holes into the mounting foot.
9. Place the lightbar in its final mounting position on the vehicle, mark the mounting hole locations off onto the mounting surface, remove the lightbar and drill the mounting holes.

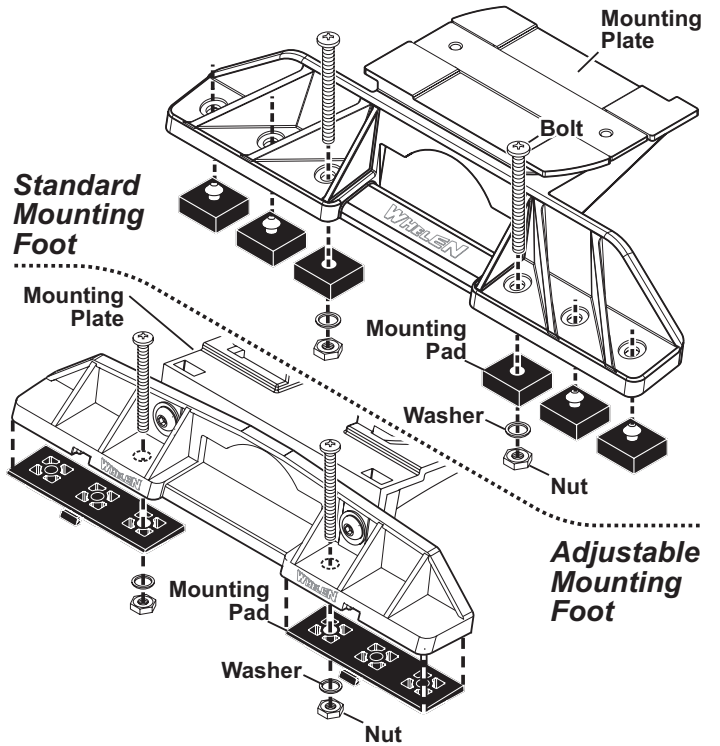

10. Place the lightbar back onto the vehicle lined up with the mounting holes and secure the mounting feet to the vehicle using the supplied hardware as shown.

Strap Mounting:

1. Locate the mounting foot, mounting plate and tinnerman plate included with your lightbar. If not already present, install the mounting plate onto the mounting foot. When properly positioned, this plate is centered from side to side on the mounting foot.

2. Flip the lightbar upside-down to expose the bottom of the extrusion and place the mounting foot onto the extrusion.
3. Rotate the mounting foot 90° in a counter-clockwise direction. Make sure that the edges of the mounting foot swing into position under the extrusion mounting lip. Install a tinnerman plate onto the extrusion in the same manner.

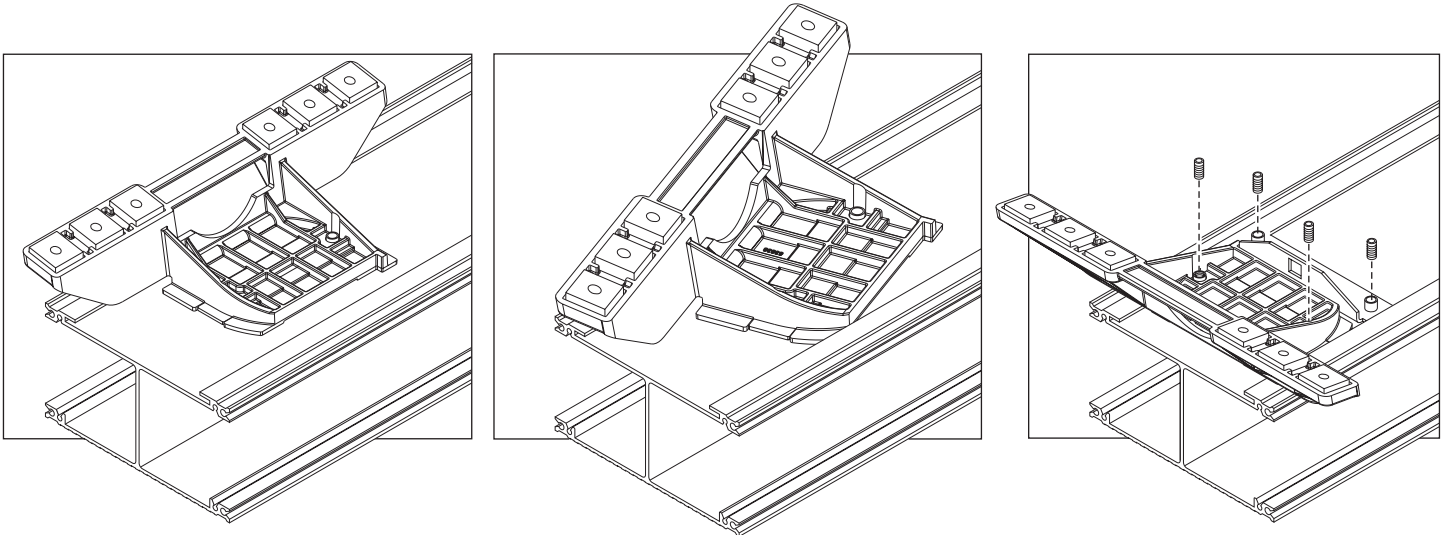

- Repeat this procedure for the remaining mounting foot and tinnerman plate and return the lightbar to its right side-up position.
- Position the lightbar onto the vehicle roof in the desired mounting location. One often selected location is directly above the B-pillars. This area is the strongest part of the roof. Refer to your lightbar manual for cable exit location, to be sure that the lightbar is facing the proper direction.
- Adjust the two mounting feet outwards so that they are as close to the edge of the roof as possible. Both mounting feet must be in full contact with the roof. Be sure that there is no less than 1/2" clearance between the roof and the lightbar at their closest point. When the mounting feet are in their proper position, lightly tighten the mounting foot allen head set screws.
- Return the lightbar to an upside down position. Slide each tinnerman plate outwards until it is fully engaged with its corresponding mounting foot. With the mounting feet and tinnerman plates in their proper positions firmly tighten all of the set screws (2 or 4 per side). Flip the lightbar right side-up and return it to its mounting position.
- Open both drivers side doors. In the area directly below the mounting foot, carefully pull the drivers side weatherstrip away from the vehicle.

- Remove enough so that the area where the mounting strap will be secured to the vehicle is exposed. Repeat procedure for passenger side.
- Insert the mounting strap through the mounting foot. Be sure that the strap fits flush against the area where it will be secured onto the vehicle. Insert the tension bolt through the mounting strap and into the tinnerman nut on the tinnerman plate. Tighten slightly with a long shafted, Phillips screwdriver. Repeat procedure for passenger side.
- If your mounting strap has mounting holes in the end of the strap, use these holes as a template to drill appropriately sized pilot holes through the strap and into the vehicle. Repeat for passenger side of the vehicle.
- Firmly tighten the tension bolts to secure the lightbar to the vehicle.

NOTE: Model MKAJ is an adjustable mounting foot. On this model you may loosen the screws on the rear of the foot and adjust the angle of the lightbar. This feature can be used if the angle of the roof is not level with the road.

IMPORTANT: To adjust the leveling screws you must use a torque wrench set at 35 to 40 ft. lbs.

Standard Mounting Foot / Model MKEZ

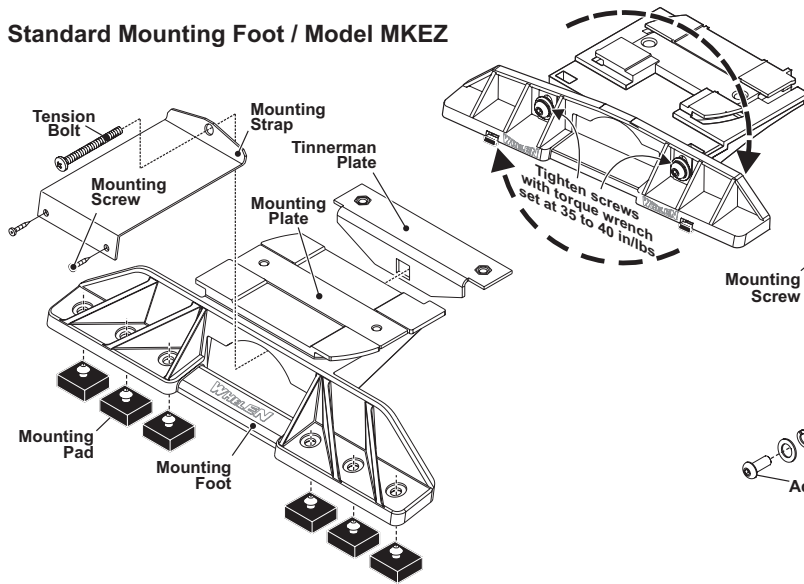

Adjustable Mounting Foot / Model MKAJ

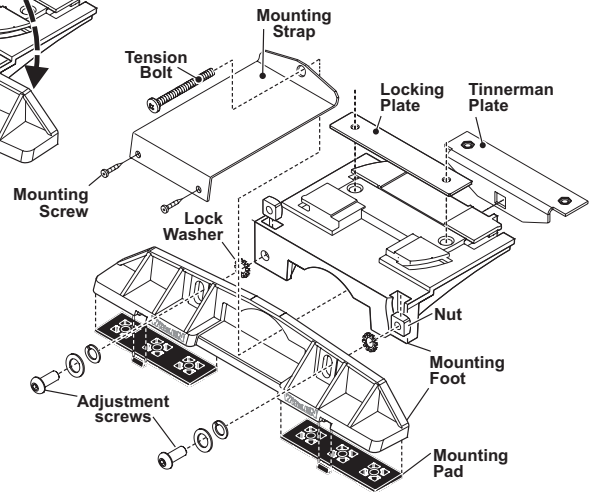

5" Mounting Foot

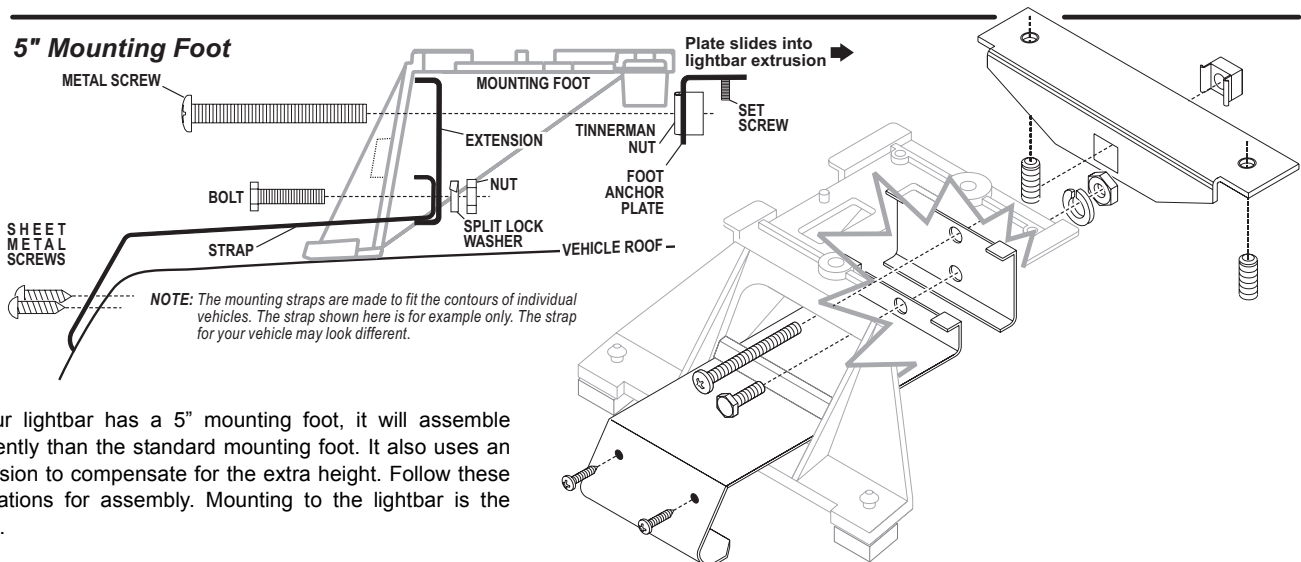

If your lightbar has a 5" mounting foot, it will assemble differently than the standard mounting foot. It also uses an extension to compensate for the extra height. Follow these illustrations for assembly. Mounting to the lightbar is the same.

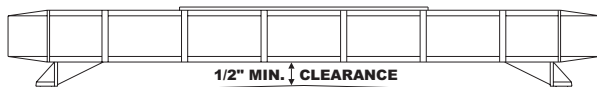

NOTE: Unless otherwise specified, the lightbar mounting feet must be sitting as close to the edge of the roof as possible. They must also be in full contact with the roof and not be hanging off the edge.

IMPORTANT: For strap mounted bars, be sure you have the right sized lightbar for your vehicle. The lightbar should be approximately the same width as the vehicle roof. If too large or small it will not mount properly to the vehicle and may come loose during driving.

CAUTION: Permanent mounting will require drilling. The installer must be sure that no vehicle components or other vital parts will be damaged. Be aware of the location of any front, side or upper air bags.

CAUTION: There may be a roof support member that spans the distance between the driver's and passenger's side. Do not drill through this member. Adjust the location of the cable access hole until the hole can be drilled without contacting this support member.

IMPORTANT! It is the responsibility of the installation technician to make sure that the installation and operation of this product will not interfere with or compromise the operation or efficiency of any vehicle equipment!

CAUTION: Using a magnetic mounted light on the outside of a vehicle, while in motion, is not recommended and is at the sole risk of the user.

Installation:

1. To protect the headliner from damage caused by drilling the cable access hole through the vehicle roof, allow a 5" to 7" distance between roof and headliner by lowering the headliner before drilling.
2. Using a 1" hole saw, drill the cable access hole. Use a round file to smooth and de-burr the edges and insert a 1" grommet (user supplied).
3. Insert the cable(s) through the cable access hole into the vehicle. Use RTV silicone to weatherproof the access hole after the cable(s) are pulled into the vehicle.
4. When routing the cable(s), be sure to use a path that avoids any vehicle components or other vital parts that may be damaged. Also be careful not to interfere with any vehicle air bags (Front, side, etc.). Route the cable(s) towards your switch panel and refer to the instructions included with the switch panel for wiring information.

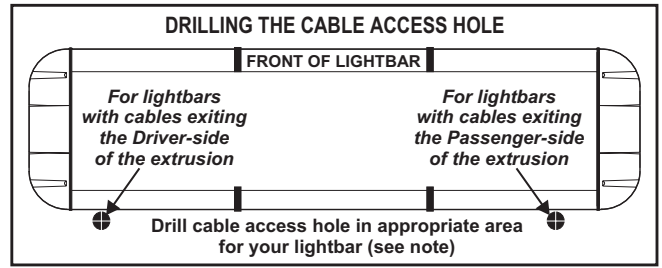

Wiring:

Your lightbar has reverse polarity protection. If the lightbar will not turn on, you may have blown an internal fuse. (See drawing on next page for fuse location.) To replace it you have to disassemble the lightbar. (See last page for assembly-disassembly instructions.)

This lightbar is equipped with an 11 conductor cable, the wire function chart below, gives: wire color, function, voltage to apply to activate the function, and how many Amps to fuse the wire at.

<u>COLOR / VOLTAGE</u>	<u>FUNCTION</u>	<u>FUSE @</u>
RED / +12VDC	LED Flasher (+) Positive	5 Amps
BLK-YEL / +12VDC	(+) Scan-Lock™	1 Amp
GRY / +12VDC	Front Corner LEDs	1Amp
WHT / +12VDC	Halogen 1 (Optional)	5 Amps
WHT-BLK / +12VDC	Inboard LEDs	5 Amps
YEL / +12VDC	Halogen 2 (Optional)	5 Amps
WHT-BLU / +12VDC	Rear Corner LEDs (Optional)	1 Amp
BLK-WHT / Ground	Halogen 1 & 2 (-) Ground (Optional)	N/A
WHT-VIO / +12VDC	Endcap LEDs	1 Amp
VIO / +12VDC	Low Power	1 Amp
BLACK / Ground	LED Flasher (-) Ground	N/A

WARNING: All Customer supplied wires that connect to the positive terminal of the battery, must be sized to supply at least 125% of the maximum operating current and **FUSED** at the battery to carry that load. **DO NOT USE CIRCUIT BREAKERS WITH THIS PRODUCT!**

Hi-Low Control:

The type of switch used is dependant on how the operator wishes the Hi/Lo feature to function:

Option 1: Latching Mode: By applying +voltage to the VIOLET wire for less than 1 sec., the power supply is "latched" into low power operation. The unit must be turned off and then back on to restore normal, Hi power operation. A momentary switch is best for this method.

Option 2: Level Mode: Applying +voltage to the VIOLET wire for more than 1 sec. holds the power supply in low power mode until that voltage is removed. A toggle switch is best for this method.

Scan-Lock™:

To cycle forward through all patterns: Apply power to the control wire of the function you want to change, then apply power to the BLACK-YELLOW (Scan-Lock™) wire for less than 1 second and release. This will change the pattern. Repeat for next pattern.

To choose a pattern: While cycling through the patterns, when you find the pattern you want let it run for more than 5 seconds and it will lock in and become the default pattern.

To reset to the factory default pattern: Turn off power, apply power to the Scan-Lock™ wire and the wire of the function you want to reset, then turn power back on.

Scan-Lock™ can be connected to a customer supplied SPST switch.

		1A SignalAlert™ Alternating
		1B SignalAlert™ Cross
		1C SignalAlert™ 3 cycles of 1A & 3 cycles of 1B
		2A CometFlash® Alternating
		2B CometFlash® Cross
		2C CometFlash @3 cycles of 1A & 3 cycles of 1B
		3A DoubleFlash Alternating
		3B DoubleFlash Cross
		3C DoubleFlash 3 cycles of 1A & 3 cycles of 1B
		4A SingleFlash Alternating
		4B SingleFlash Cross
		4C SingleFlash 3 cycles of 1A & 3 cycles of 1B
		6 SteadyFlash 1 & 2 Steady 3 & 4 SingleFlash (SIM.)
		7 Steady 1, 2, 3 & 4 Steady

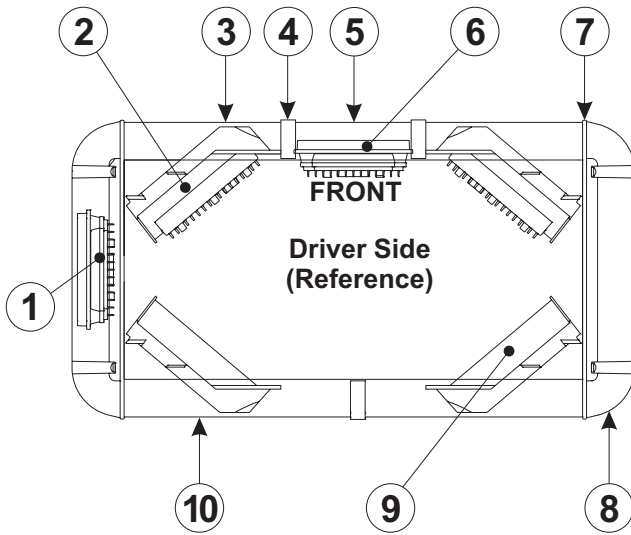
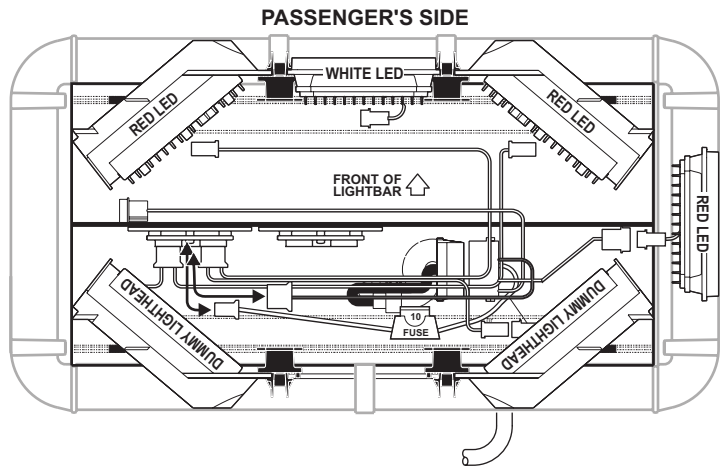
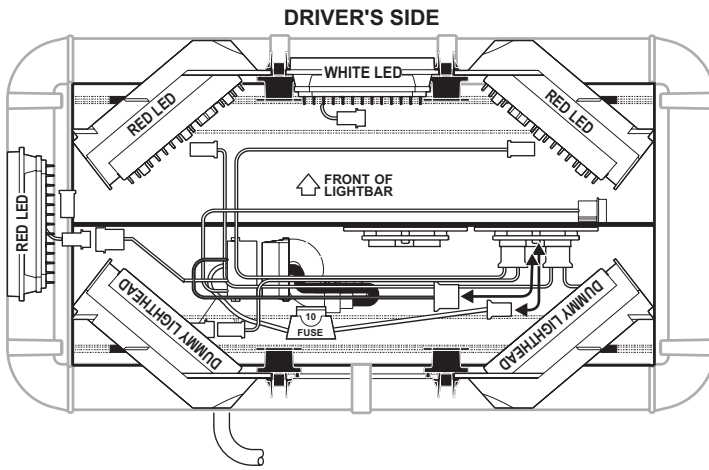

QTY	ITEM	PART NUMBER	DESCRIPTION
		01-0684222-36	NFPA Freedom Mini / 4-LEDs / Perm Mount (Pair)
2	1	02-0364528255	400 LED (SPLIT) RED/RED
4	2	01-0263814-50	LED CORNER LINEAR (RED)
4	3	68-1983817-30	LENS (CLEAR) 6.562"
6	4	02-0341448-30	LENS DIVIDER (CLEAR)
2	5	68-1983816-30	LENS (CLEAR) 5.000"
2	6	02-0364528233	400 LED (SPLIT) WHT/WHT
4	7	38-0283381-00	ENDCAP GASKET
4	8	68-1183369-30	ENDCAP (CLEAR)
4	9	68-5983915-01	CORNER FILLER
4	10	68-1984104-30	LENS (CLEAR) 9.250"

<u>WIRE COLOR & VOLTAGE</u>	<u>FUNCTION</u>	<u>FUSE @</u>
RED / +12VDC	LED Flasher (+) Positive	5 Amp
BLACK-YELLOW / +12VDC	(+) Scan-Lock™	1 Amp
GRAY / +12VDC	Front Corner LED's	1 Amp
WHITE / +12VDC	Halogen 1 (Optional)	5 Amp
WHITE-BLACK / +12VDC	Inboard LED's	5 Amp
YELLOW / +12VDC	Halogen 2 (Optional)	5 Amp
WHITE-BLUE / +12VDC	Rear Corner LED's (Optional)	1 Amp
BLACK-WHITE (-)	Halogen 1 & 2 (-) Ground (Optional)	N/A
WHITE-VIOLET / +12VDC	Endcap LED's	1 Amp
VIOLET / +12VDC	Low Power	1 Amp
BLACK / Ground	LED Flasher (-) Ground	N/A

Note: Should you need to service or repair your lightbar, the diagrams below will show you how to gain access.

Installing Endcap Gasket & Alley Light

Place the endcap gasket into position on the endcap, locating all tabs and holes. Align the reflector assembly of the alley light with the 4 bosses in the endcap and press the reflector in place until the 4 barbs engage around the reflector.

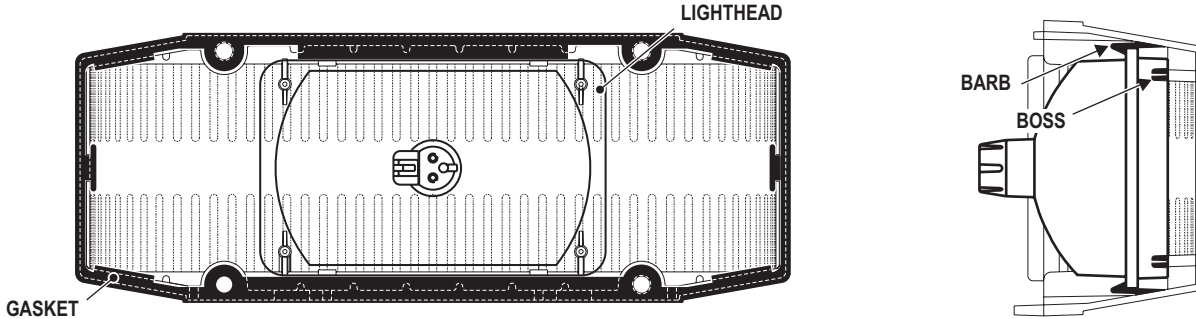

Lighthead Mounting Bracket

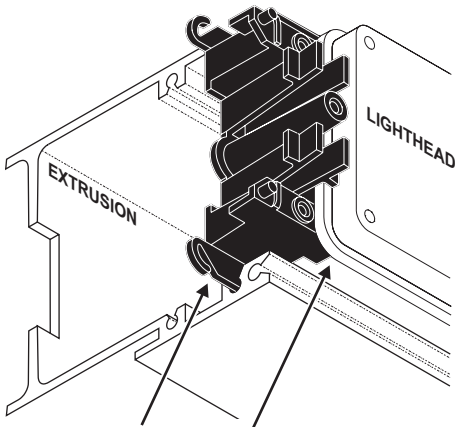

Ears on mounting bracket slide into the channels in the extrusion. Lighthead mounting holes, snap into the raised bosses on the mounting bracket.

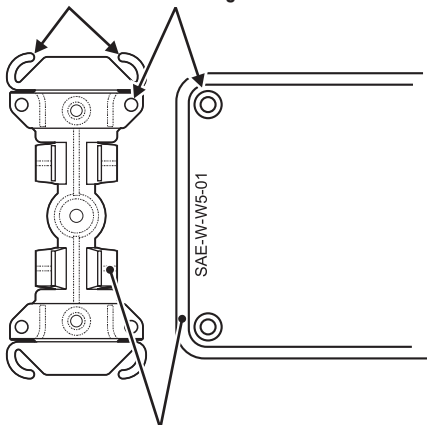

The edge of the lighthead snaps into the clips on the mounting bracket.

Installing a Corner LED

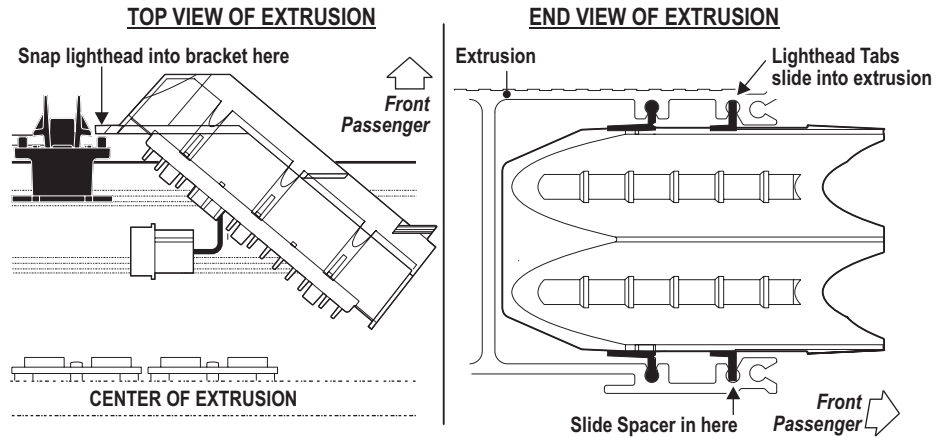

Removing the Endcap and Lenses

Remove the four screws (A) that hold the endcap (B) on and pull the endcap and gasket (C) off. Slide the lenses (D) out of the lightbar, to gain access to the extrusion. When reinstalling the endcap, first place the gasket into position on the endcap. Be sure to line up all the tabs and holes on the gasket.

