

WHELEN[®]

ENGINEERING COMPANY INC.

51 Winthrop Road,
Chester, Connecticut 06412
Phone: (860) 526-9504
Fax: (860) 526-4078
Internet: www.whelen.com
Sales e-mail: autosale@whelen.com
Canadian Sales e-mail: autocan@whelen.com
Customer Service e-mail: custserv@whelen.com

Installation Guide Freedom™ NFPA Lightbar

Safety First

This document provides all the necessary information to allow your Whelen product to be properly and safely installed. Before beginning the installation and/or operation of your new product, the installation technician and operator must read this manual completely. Important information is contained herein that could prevent serious injury or damage.

- Proper installation of this product requires the installer to have a good understanding of automotive electronics, systems and procedures.
- If mounting this product requires drilling holes, the installer **MUST** be sure that no vehicle components or other vital parts could be damaged by the drilling process. Check both sides of the mounting surface before drilling begins. Also de-burr any holes and remove any metal shards or remnants. Install grommets into all wire passage holes.
- If this manual states that this product may be mounted with suction cups, magnets, tape or Velcro™, clean the mounting surface with a 50/50 mix of isopropyl alcohol and water and dry thoroughly.
- Do not install this product or route any wires in the deployment area of your air bag. Equipment mounted or located in the air bag deployment area will damage or reduce the effectiveness of the air bag, or become a projectile that could cause serious personal injury or death. Refer to your vehicle owners manual for the air bag deployment area. The User/Installer assumes full responsibility to determine proper mounting location, based on providing ultimate safety to all passengers inside the vehicle.
- For this product to operate at optimum efficiency, a good electrical connection to chassis ground must be made. The recommended procedure requires the product ground wire to be connected directly to the **NEGATIVE (-)** battery post.
- If this product uses a remote device to activate or control this product, make sure that this control is located in an area that allows both the vehicle and the control to be operated safely in any driving condition.
- Do not attempt to activate or control this device in a hazardous driving situation.
- This product contains either strobe light(s), halogen light(s), high-intensity LEDs or a combination of these lights. Do not stare directly into these lights. Momentary blindness and/or eye damage could result.
- Use only soap and water to clean the outer lens. Use of other chemicals could result in premature lens cracking (crazing) and discoloration. Lenses in this condition have significantly reduced effectiveness and should be replaced immediately. Inspect and operate this product regularly to confirm its proper operation and mounting condition. Do not use a pressure washer to clean this product.
- It is recommended that these instructions be stored in a safe place and referred to when performing maintenance and/or reinstallation of this product.
- **FAILURE TO FOLLOW THESE SAFETY PRECAUTIONS AND INSTRUCTIONS COULD RESULT IN DAMAGE TO THE PRODUCT OR VEHICLE AND/OR SERIOUS INJURY TO YOU AND YOUR PASSENGERS!**

For warranty information regarding this product, visit www.whelen.com/warranty

Permanent Mounting:

1. Locate the mounting foot and mounting plate included with your lightbar. If not already present, install the mounting plate onto the mounting foot. When properly positioned, this plate is centered from side to side on the mounting foot.
2. Flip the lightbar upside-down to expose the bottom of the extrusion and place the mounting foot onto the extrusion.
3. Rotate the mounting foot 90° in a counter-clockwise direction. Make sure that the edges of the mounting foot swing into position under the extrusion mounting lip.
4. Repeat this procedure for the remaining mounting foot and return the lightbar to its right side-up position.
5. Position the lightbar onto the vehicle roof in the desired mounting location. One often selected location is directly above the B-pillars. This area is the strongest part of the roof. Refer to your lightbar manual for cable exit location, to be sure that the lightbar is facing the proper direction.
6. Adjust the two mounting feet outwards so that they are as close to the edge of the roof as possible. Make sure that both mounting feet are in full contact with the roof. Be sure that there is no less than 1/2" clearance between the roof and the lightbar at their closest point. When the mounting feet are in their proper position, lightly tighten the mounting foot allen head set screws.
7. Turn the lightbar upside down and firmly tighten all of the set screws from step 6 (2 or 4 per side).
8. On the mounting foot, remove either the two outer or inner rubber mounting pads. Carefully remove the mounting pad's guide dart so the hole through the center of the pad is exposed then replace the pad (Standard foot only). On the adjustable foot, use the hole in the pad as a guide to drill the two holes into the mounting foot.
9. Place the lightbar in its final mounting position on the vehicle, mark the mounting hole locations off onto the mounting surface, remove the lightbar and drill the mounting holes.

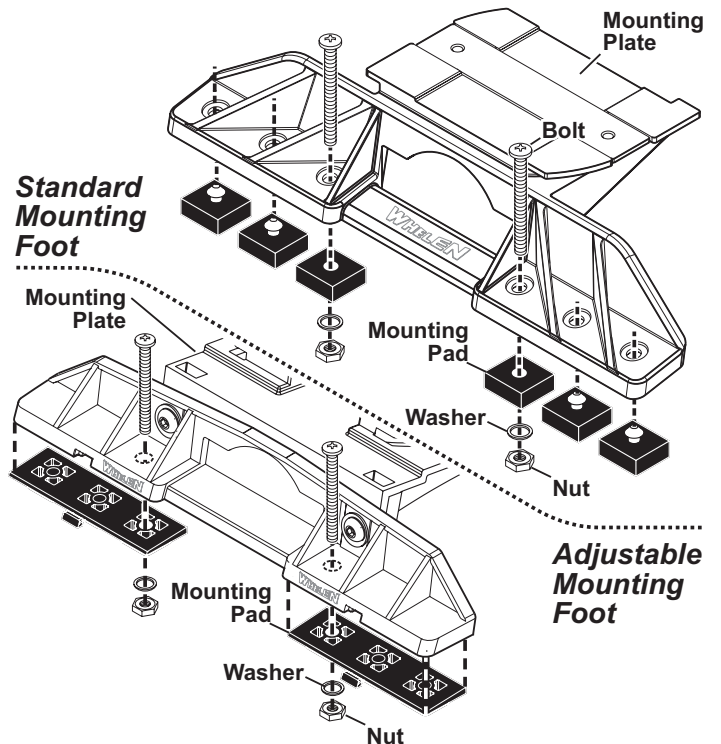

10. Place the lightbar back onto the vehicle lined up with the mounting holes and secure the mounting feet to the vehicle using the supplied hardware as shown.

Strap Mounting:

1. Locate the mounting foot, mounting plate and tinnerman plate included with your lightbar. If not already present, install the mounting plate onto the mounting foot. When properly positioned, this plate is centered from side to side on the mounting foot.

2. Flip the lightbar upside-down to expose the bottom of the extrusion and place the mounting foot onto the extrusion.
3. Rotate the mounting foot 90° in a counter-clockwise direction. Make sure that the edges of the mounting foot swing into position under the extrusion mounting lip. Install a tinnerman plate onto the extrusion in the same manner.

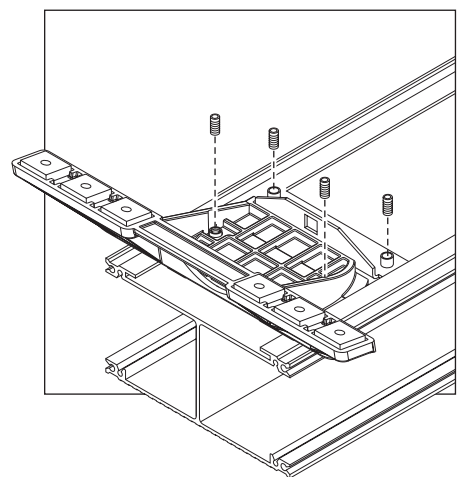
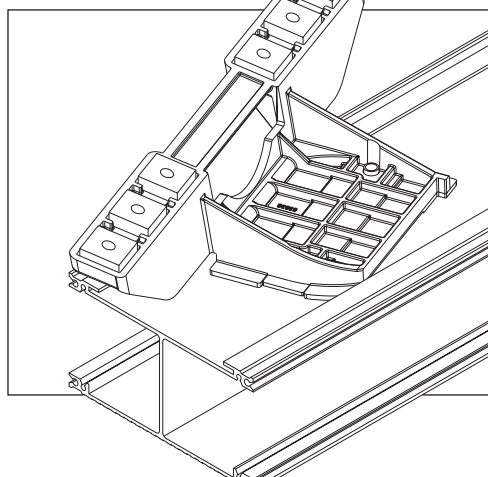
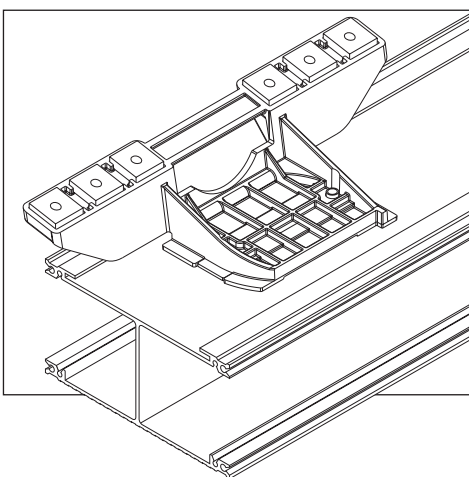

- Repeat this procedure for the remaining mounting foot and tinnerman plate and return the lightbar to its right side-up position.
- Position the lightbar onto the vehicle roof in the desired mounting location. One often selected location is directly above the B-pillars. This area is the strongest part of the roof. Refer to your lightbar manual for cable exit location, to be sure that the lightbar is facing the proper direction.
- Adjust the two mounting feet outwards so that they are as close to the edge of the roof as possible. Both mounting feet must be in full contact with the roof. Be sure that there is no less than 1/2" clearance between the roof and the lightbar at their closest point. When the mounting feet are in their proper position, lightly tighten the mounting foot allen head set screws.
- Return the lightbar to an upside down position. Slide each tinnerman plate outwards until it is fully engaged with its corresponding mounting foot. With the mounting feet and tinnerman plates in their proper positions firmly tighten all of the set screws (2 or 4 per side). Flip the lightbar right side-up and return it to its mounting position.
- Open both drivers side doors. In the area directly below the mounting foot, carefully pull the drivers side weatherstrip away from the vehicle.

- Remove enough so that the area where the mounting strap will be secured to the vehicle is exposed. Repeat procedure for passenger side.
- Insert the mounting strap through the mounting foot. Be sure that the strap fits flush against the area where it will be secured onto the vehicle. Insert the tension bolt through the mounting strap and into the tinnerman nut on the tinnerman plate. Tighten slightly with a long shafted, Phillips screwdriver. Repeat procedure for passenger side.
- If your mounting strap has mounting holes in the end of the strap, use these holes as a template to drill appropriately sized pilot holes through the strap and into the vehicle. Repeat for passenger side of the vehicle.
- Firmly tighten the tension bolts to secure the lightbar to the vehicle.

NOTE: Model MKAJ is an adjustable mounting foot. On this model you may loosen the screws on the rear of the foot and adjust the angle of the lightbar. This feature can be used if the angle of the roof is not level with the road.

IMPORTANT: To adjust the leveling screws you must use a torque wrench set at 35 to 40 ft. lbs.

Standard Mounting Foot / Model MKEZ

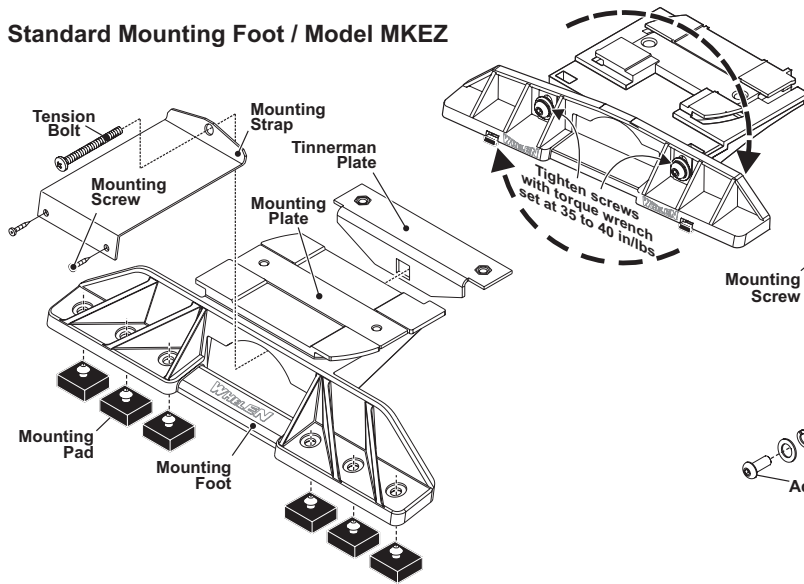

Adjustable Mounting Foot / Model MKAJ

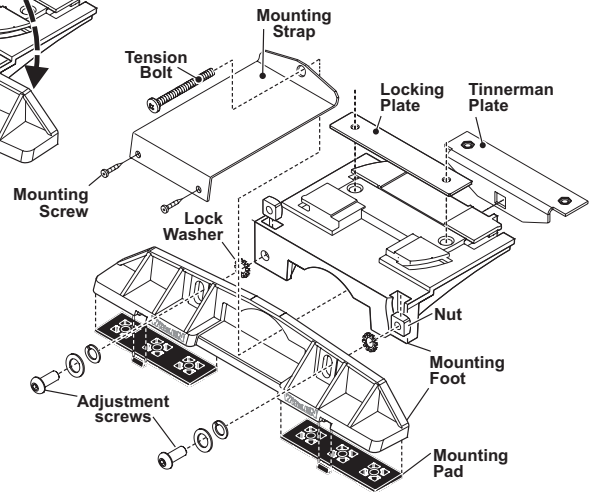

5" Mounting Foot

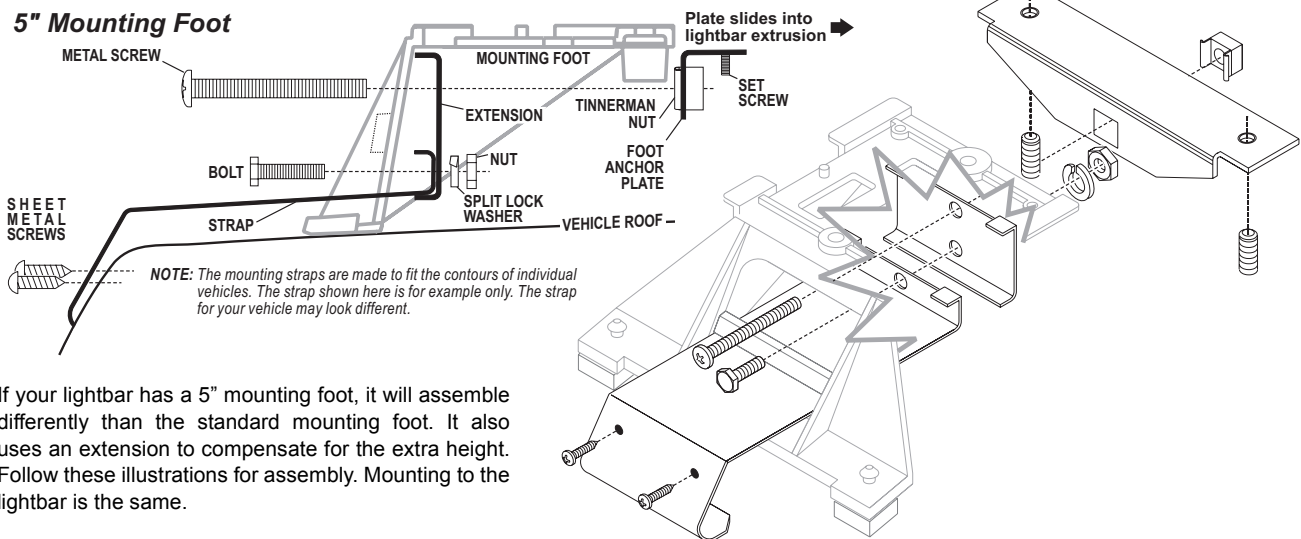

If your lightbar has a 5" mounting foot, it will assemble differently than the standard mounting foot. It also uses an extension to compensate for the extra height. Follow these illustrations for assembly. Mounting to the lightbar is the same.

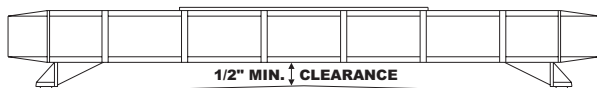

IMPORTANT: For strap mounted bars, be sure you have the right sized lightbar for your vehicle. The lightbar should be approximately the same width as the vehicle roof. If too large or small it will not mount properly to the vehicle and may come loose during driving.

NOTE: Unless otherwise specified, the lightbar mounting feet must be sitting as close to the edge of the roof as possible. They must also be in full contact with the roof and not be hanging off the edge.

Wiring:

1. To protect the headliner from damage caused by drilling the cable access hole through the vehicle roof, allow a 5" to 7" distance between the roof and the headliner by lowering the headliner before drilling.

WARNING! There is a roof support member that spans the distance between the driver's and passenger's side. DO NOT DRILL THROUGH THIS MEMBER! Adjust the location until the hole can be drilled without contacting this support member. Refer to "Safety First" on Page 1 for important precautionary information.

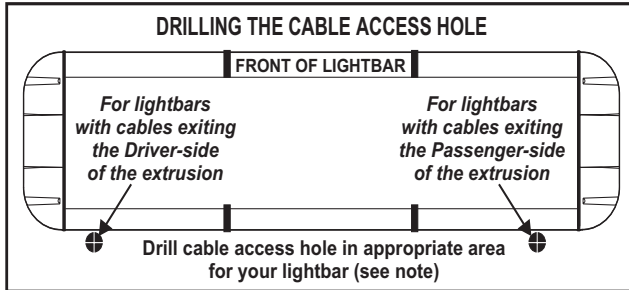

2. Using a 1" hole saw, drill the cable access hole.
3. Use a round file to de-burr the edges of the cable access hole and insert a 1" grommet (customer supplied) into the hole.
4. Insert the cables through the cable access hole into the vehicle. Use RTV silicone to weatherproof the access hole after the cables are pulled completely into the vehicle.
5. Route the cables one at a time to your power source. It is left to the installation technician's discretion where to run the cables, as vehicles will vary.

Connecting the Cables:

WARNING! All customer supplied wires that connect to the positive terminal of the battery must be sized to supply at least 125% of the maximum operating current and FUSED at the battery to carry that load. DO NOT USE CIRCUIT BREAKERS WITH THIS PRODUCT!

Power Cable:

1. Route the power cable towards the firewall. Again the wires path is left to the installation technician's discretion.
2. Follow the factory wiring harness through the firewall. It may be necessary to drill a hole in the firewall. If so, be absolutely sure that there are no components that could be damaged by drilling. Insert a grommet into the hole, to protect the cable.

1. Route the cable along the factory wiring harness towards the battery.
2. Install a 40 amp fuse block (customer supplied) on the end of the RED wire in the power cable. Remove the fuse from the fuse block before connecting any wires to the battery.
3. Connect the fuse block to the POSITIVE (+) terminal on the battery. There can not be more than two (2) feet of wire between the fuse block and the battery. The wire between the fuse block and the battery is "unprotected", do not allow this wire to come into contact with any other wires.
4. Connect the BLACK wire to the factory chassis ground adjacent to the battery.

Control Cable:

Extend the control cable to your switch panel and make the appropriate connections, using the information provided on page 3. When you apply +12 VDC to a Control Cable wire, you activate its function. The control cable connects to your control head or switch box and is fused there. Typical fusing is 5 Amps.

Note: The wire functions listed in this manual are the factory default settings for a fully loaded lightbar. To find the correct wire functions for the lightbar you ordered, refer to the switch operations sheet included with your lightbar.

White-Violet / Scan-Lock™

TO CYCLE FORWARD THROUGH ALL PATTERNS: Choose the Scan-Lock™ wire controlling the function you wish to change the flash pattern on and apply +12 volts to that wire for less than 1 second and release. This will change the pattern. Repeat to go to next pattern.

TO CHOOSE A PATTERN: While cycling through the patterns, when you find the pattern you want let it run for more than 5 seconds and it will lock in and become the default pattern.

TO RESET TO THE FACTORY DEFAULT PATTERN: Turn off the option you want to reset, apply +12 volts to the Scan-Lock™ function wire of that option then turn the option back on.

Available LED Scan-Lock™ Patterns: SignalAlert™ 75 (Default pattern) / CometFlash© 75 / DoubleFlash 150 / DoubleFlash 75 / SingleFlash 375 / SingleFlash 150 / SingleFlash 75 / ActionFlash™ 75 / ModuFlash™ 75 / ActionScan™

Front Inboards only: Single 75, Driver Steady / 2 Lamps Steady

Violet / Low Power

The type of switch used is dependant on how the operator wishes the Hi/Lo feature to function:

Latching Mode: By applying +12 VDC voltage to the Violet wire for less than 1 sec., the power supply is "latched" into low power operation. The unit must be turned off and then back on to restore normal, Hi power operation. (A Momentary Switch is Preferred)

Level Mode: Applying +12 VDC voltage to the Violet wire for more than 1 sec. holds the power supply in low power mode until voltage is removed. (A Toggle Switch is Preferred)

Wiring Designations: The control wire functions shown below are given for a general reference only and may not match the wire designations of your individual lightbar. For the wire functions of the specific lightbar you ordered, refer to the wiring sheet attached to the instruction manual shipped with the lightbar.

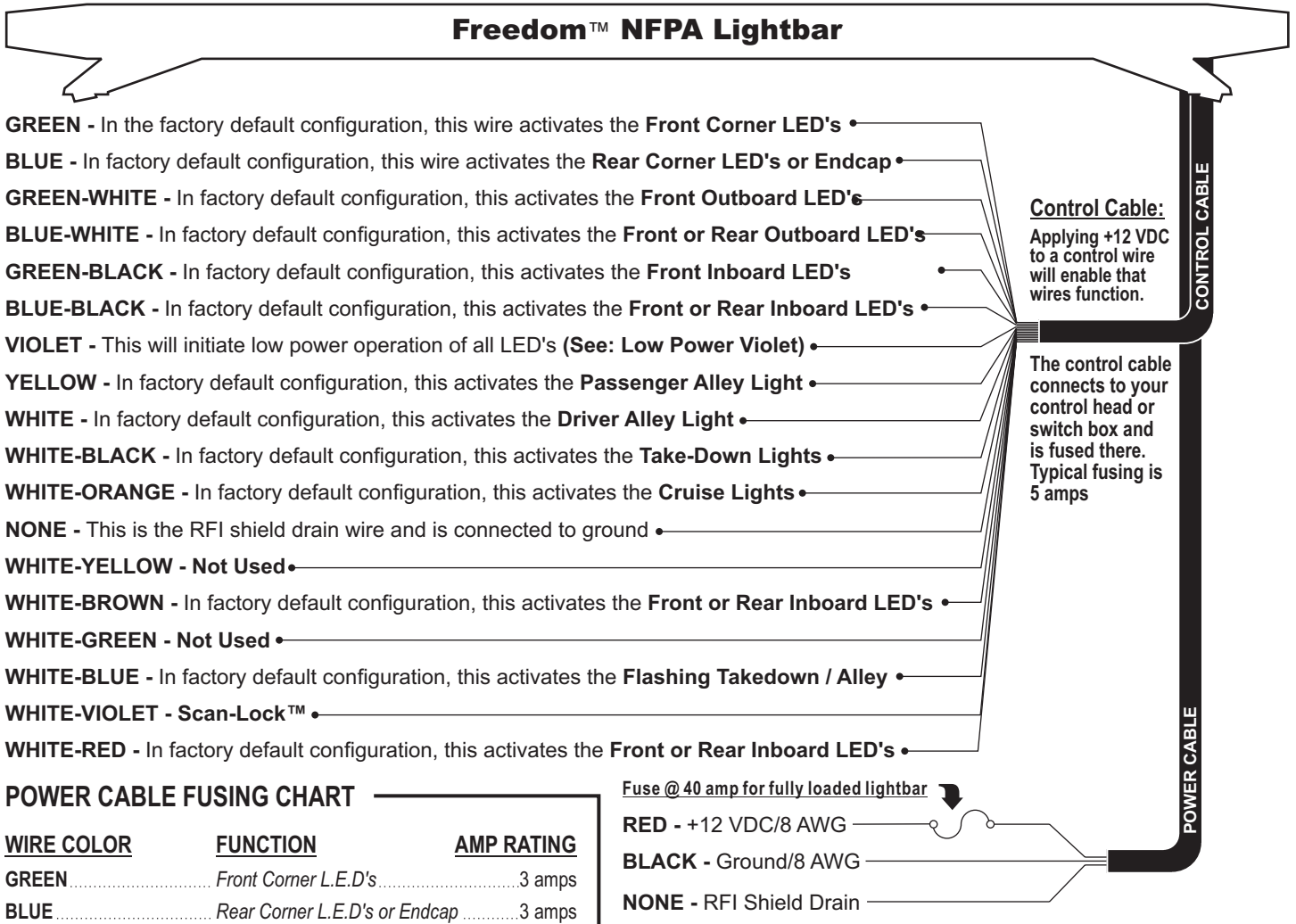

- GREEN** - In the factory default configuration, this wire activates the **Front Corner LED's**
- BLUE** - In factory default configuration, this wire activates the **Rear Corner LED's or Endcap**
- GREEN-WHITE** - In factory default configuration, this activates the **Front Outboard LED's**
- BLUE-WHITE** - In factory default configuration, this activates the **Front or Rear Outboard LED's**
- GREEN-BLACK** - In factory default configuration, this activates the **Front Inboard LED's**
- BLUE-BLACK** - In factory default configuration, this activates the **Front or Rear Inboard LED's**
- VIOLET** - This will initiate low power operation of all LED's (**See: Low Power Violet**)
- YELLOW** - In factory default configuration, this activates the **Passenger Alley Light**
- WHITE** - In factory default configuration, this activates the **Driver Alley Light**
- WHITE-BLACK** - In factory default configuration, this activates the **Take-Down Lights**
- WHITE-ORANGE** - In factory default configuration, this activates the **Cruise Lights**
- NONE** - This is the RFI shield drain wire and is connected to ground
- WHITE-YELLOW - Not Used**
- WHITE-BROWN** - In factory default configuration, this activates the **Front or Rear Inboard LED's**
- WHITE-GREEN - Not Used**
- WHITE-BLUE** - In factory default configuration, this activates the **Flashing Takedown / Alley**
- WHITE-VIOLET - Scan-Lock™**
- WHITE-RED** - In factory default configuration, this activates the **Front or Rear Inboard LED's**

<u>WIRE COLOR</u>	<u>FUNCTION</u>	<u>AMP RATING</u>
GREEN	Front Corner L.E.D's	3 amps
BLUE	Rear Corner L.E.D's or Endcap	3 amps
GREEN-WHITE	Front Outboard L.E.D's	3 amps
BLUE-WHITE	Front or Rear Outboard L.E.D's	3 amps
GREEN-BLACK	Front Inboard L.E.D's	3 amps
BLUE-BLACK	Front or Rear Inboard L.E.D's	3 amps
VIOLET	Low Power	0.5 amps
YELLOW	Passenger Alley Light	2.5 amps
WHITE	Driver Alley Light	2.5 amps
WHITE-BLACK	Take-Down Lights	5 amps
WHITE-ORANGE	Cruise Lights	5 amps
WHITE-BLUE	Flashing Takedowns	2.5 amps

Power Cable Fusing Chart: After determining which function wires you will use, add up the amp rating of each function wire. You must then multiply this by 1.25 (see warning) and fuse the RED power wire at this rating.

EXAMPLE: If you are using the YELLOW, WHITE, & WHITE/ BROWN function wires, the total amp draw is 7.5 amps. Multiply this by 1.25 which comes out to 9.375 amps. You must fuse the RED power wire at 10 amps.

All Options May not be present on all Light Bars.

The lightbar owner should familiarize himself with the following component replacement procedures to assure proper assembly and re-assembly of this product.

Installing Endcap Gasket & Alley Light

Place the endcap gasket into position on the endcap, locating all tabs and holes. Align the reflector assembly of the alley light with the 4 bosses in the endcap and press the reflector in place until the 4 barbs engage around the reflector.

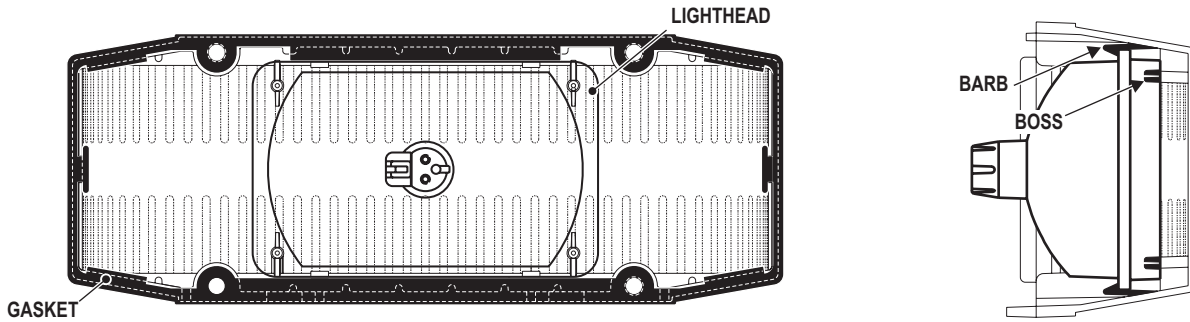

Lighthouse Mounting Bracket

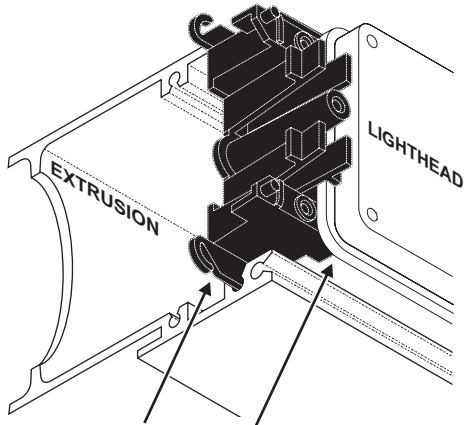

Ears on mounting bracket slide into the channels in the extrusion.

Lighthouse mounting holes, snap into the raised bosses on mounting bracket.

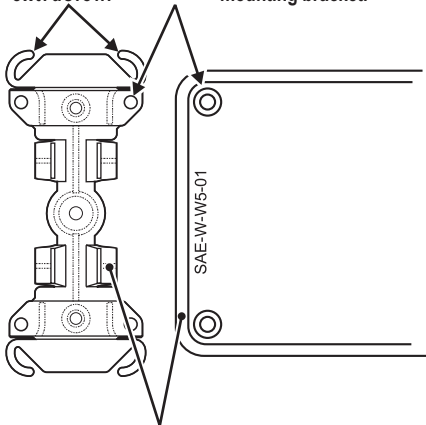

The edge of the lighthead snaps into the clips on the mounting bracket.

Installing a Corner LED

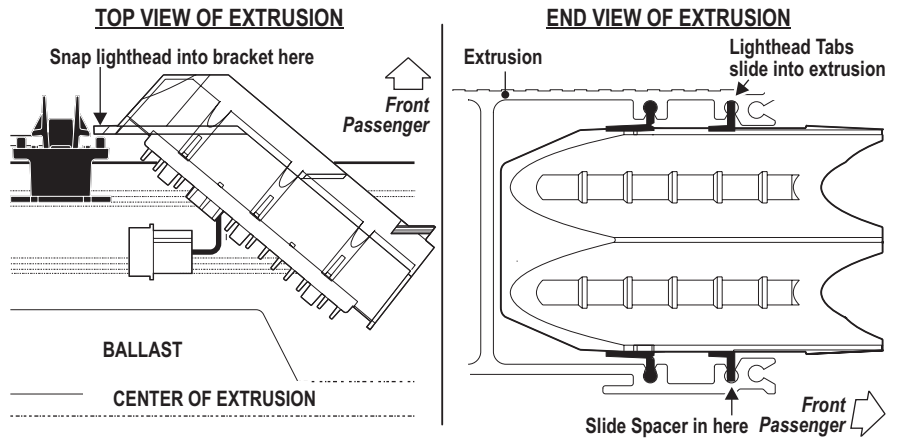

Removing the Endcap and Lenses

Remove the four screws (A) that hold the endcap (B) on and pull the endcap and gasket (C) off. Slide the lenses (D) out of the lightbar, to gain access to the extrusion. When reinstalling the lenses and spacers, install the cord seal (See below). When reinstalling the endcap, place the endcap gasket into it's position on the endcap and line up all the tabs and holes. Spacers (not shown) mount the same as lenses.

Seal Cord Installation:

- 1 - Cut the seal cord approx. 1-1/2" longer than the extrusion on each side.
- 2 - Rub silicone over the cord seal leaving 3 - 4 inches on one end dry.
- 3 - Beginning with 1 corner lens, start the lens into the bottom lens track. Place the cord seal onto the groove in the top of the lens leaving 1 to 2 inches
- 4 - Hold onto the left end of the seal hanging out and slide the corner lens into position.
- 5 - From the opposite end of the lightbar, pull the seal cord tight and install the remaining lenses and divider.

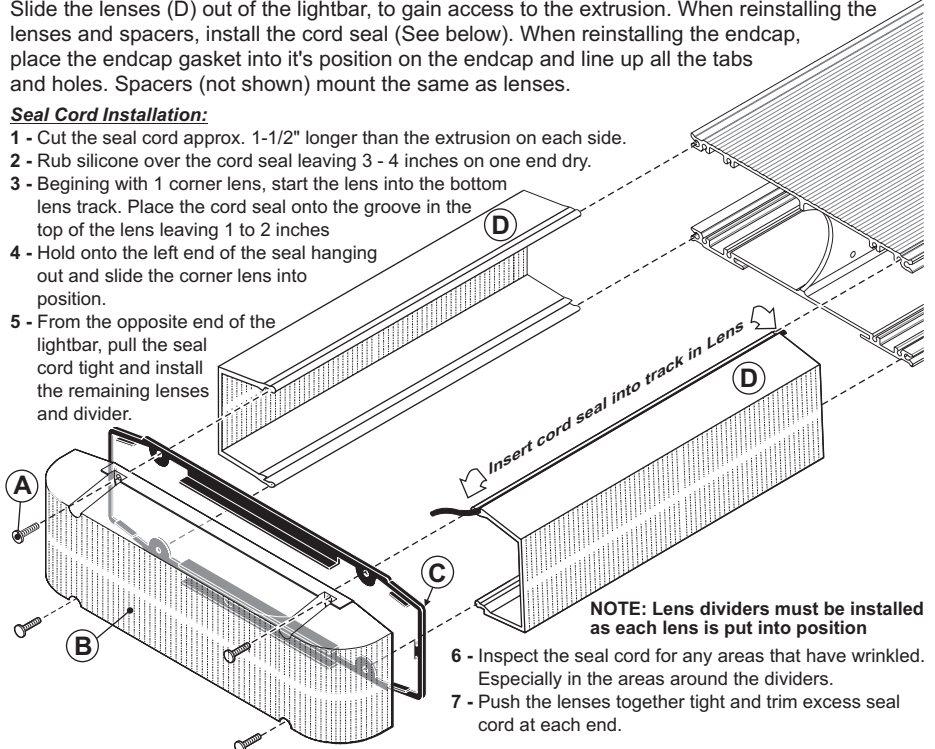

- 6 - Inspect the seal cord for any areas that have wrinkled. Especially in the areas around the dividers.
- 7 - Push the lenses together tight and trim excess seal cord at each end.