





## Notes for painting the access door and cover plate

### Safety symbols and signal words

 This is the safety alert symbol. This symbol alerts you to potential hazards that can kill or hurt you and others.

 **WARNING** indicates a hazardous situation which, if not avoided, could result in death or serious injury.

 **NOTICE** is used to address practices not related to physical injury.

 Other important information or tips.

### Important Information

 Observe all safety notes/instructions for painting the access door and cover plate.

#### **The following parts (see Figure 2) may be painted:**

- The white cover plate
- The white outer surfaces of the access door

#### **Material of the parts:**

- The parts are made from a polycarbonate material.
- Check whether the paint to be used is suitable for polycarbonate.
- For optimum adhesion of the paint it may be necessary to apply a primer to the surfaces that will be painted.
- Follow the recommendations of the paint manufacturer.

 **NOTICE** Use of unsuitable paints may damage the parts.

#### **The following parts (see Figure 1) must not be painted:**

- The black venting grid
- The turn lock
- The webbings

## Work before painting

**i** In order to simplify painting and reduce the work for masking, the turn lock and the venting grid can be removed/disassembled.

### **Please follow the steps below to remove the venting grid and the turn lock:**

1. Open the access door.
2. Remove the venting grid:
  - Using a Torx T-15 remove the 4 screws securing the venting grid to the access door.
  - After removing the screws, depress the four (4) clips on the side of the venting grid and remove it as shown in Fig. 1.
3. Remove the turn lock:  
To remove the turn lock, depress the four (4) clips and remove it as shown in Fig. 1.
4. Mask the venting grid opening from the back side (side with waffle pattern).
5. Close the access door and fix it in the closed position for painting.
  - This can be done with help of tape that joins the flue fan and the edge of the turn lock opening (see Fig. 2 for this detail).
  - Remove any tape that hangs over the edge by more than 0.12 in. (3 mm).
  - Finally mask the turn lock opening with tape (hatched area). Take care not to exceed 0.12 in. (3 mm) from the edge (this is the area that will be covered by the turn lock).
6. Paint the access door and the cover plate

## Work after painting

7. Remove all masking
8. Assemble the venting grid and the turn lock in the reverse order. Make sure that they are installed in the right direction.
9. Ensure turn lock operates correctly (if unsure: see chapter "Closing the access door" in your AquaGo manual)

## Painting a detached access door

**i** If necessary for masking or painting, the access door can be detached temporarily.

- Remove the four (4) screws that fix the webbings.
- Fix the webbings again after painting.

### **⚠ WARNING**

#### **Danger of personal injury or damage to the recreational vehicle.**

Unsecured webbings cause the access door to become loose and it may fall off when you are driving the RV.

- After painting, the webbings must be fixed firmly to the access door with the original screws.

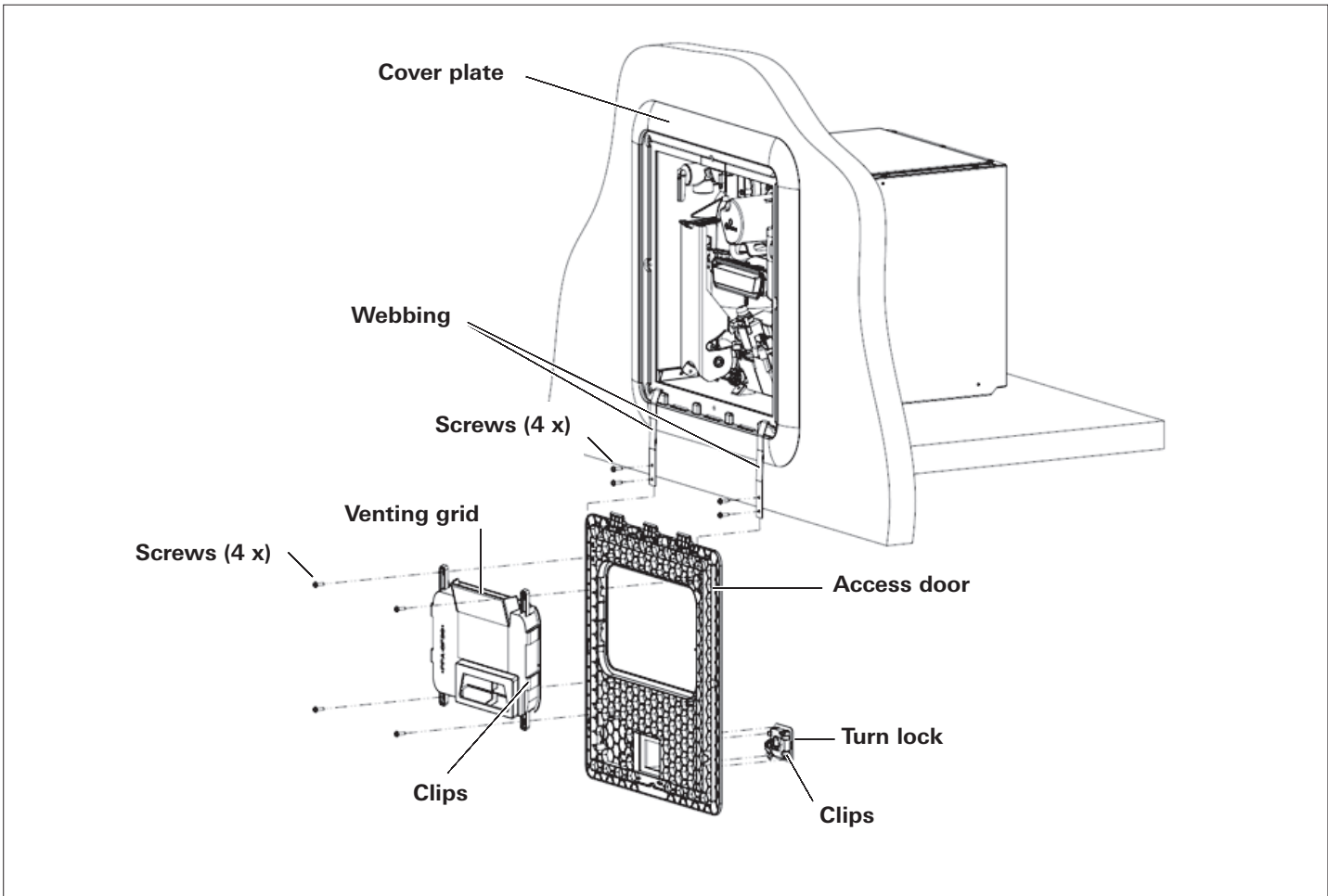

Fig. 1

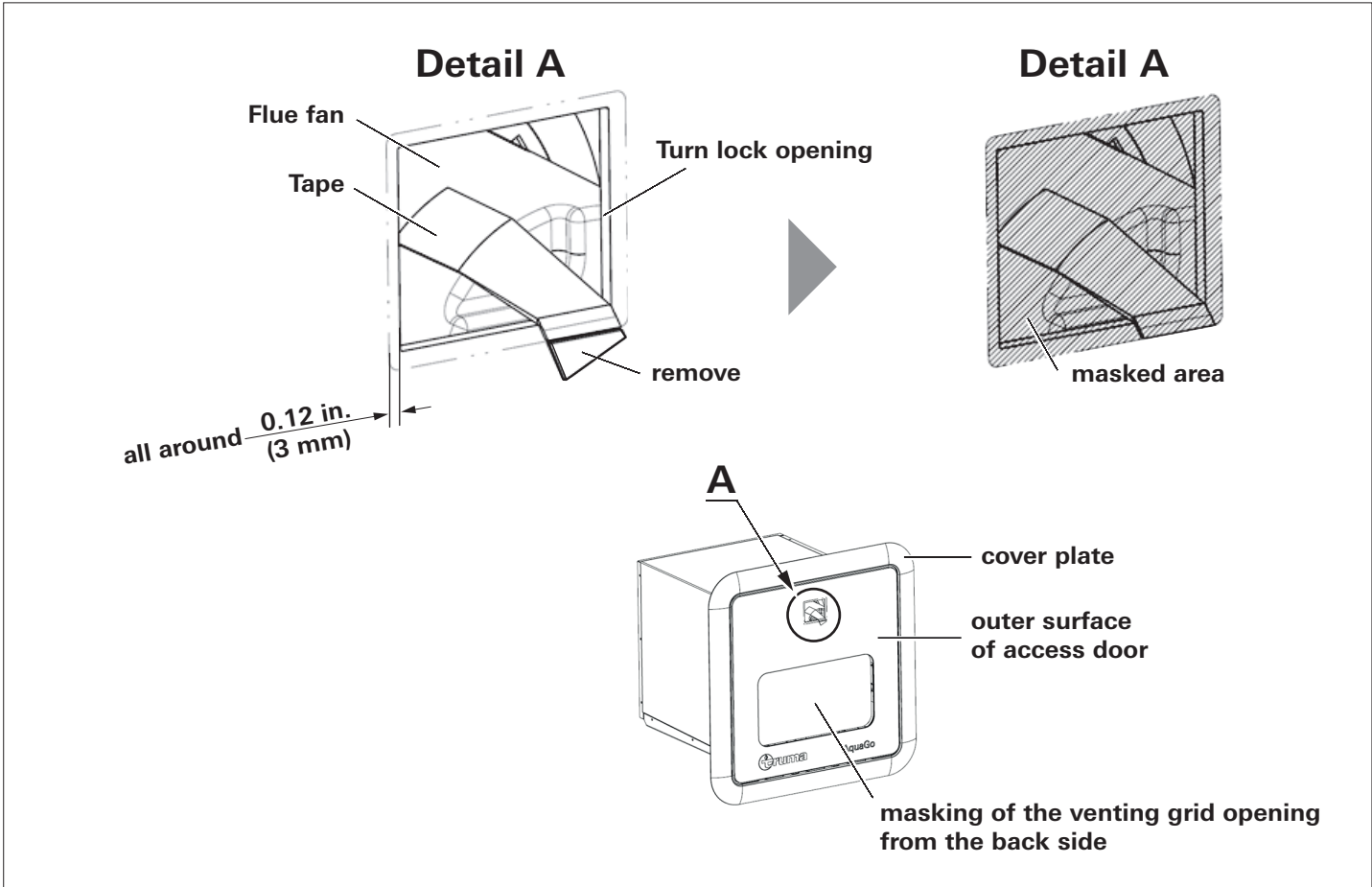

Fig. 2

**USA** In case you encounter any problems,  
please contact the Truma Service Center  
at 855-558-7862 or one of our authorized  
service partners. For details see:  
[www.truma.net](http://www.truma.net)

Please have the model number and se-  
rial number (on water heater's type plate)  
handy when you call.

**Manufacturing**

Truma Gerätetechnik GmbH & Co. KG  
Wernher-von-Braun-Straße 12  
85640 Putzbrunn  
Germany  
[www.truma.com](http://www.truma.com)

**Sales**

Truma Corp  
825 East Jackson Blvd.  
Elkhart, IN 46516  
USA  
Toll Free 1-855-558-7862  
Fax 1-574-538-2426  
[service@trumacorp.com](mailto:service@trumacorp.com)  
[www.truma.net](http://www.truma.net)