

e-ASK

electronic **A**ccess **S**ecurity **K**eyless-entry

TriMark Full-Feature e-FOB / e-PAD Installation Instructions

FCC ID: TV2EFOB1

(UM17 ~ 22271-03)



500 Bailey Avenue
P.O. Box 350
New Hampton, Iowa 50659 U.S.A.
Tel: 641-394-3188
Fax: 641-394-2392
www.trimarkcorp.com

Table of Contents

Introduction	1
e-FOB Operation and Features - Standard Mode	2
e-FOB Operation and Features - Cargo Mode.....	3
Standard e-PAD Operation and Features	4
Lock Doors With Keypad.....	4
Using Secure Operations	4
Available Secure Operations.....	4
Doorbell e-PAD Operation and Features	5
Lock Doors With Keypad.....	5
Door Bell Operation	5
Using Secure Operations	5
Available Secure Operations.....	5
More e-PAD Features.....	6
Protective Deactivating Security Feature	6
Buzzer Operation	6
Grab Handle Lighting	6
Dome Light Activation	6
Emergency Override	6
Teaching Additional FOB Transmitters	7
Training Wireless Switches	8
Teaching Keypad New Authority and Access Codes	9
Assign New Access Codes.....	11
Smart LED:	12
Dip Switch Setting Assignment.....	12
DIP Switch #1: Cargo/Standard Mode	13
DIP Switch #2: Sustained Output	13
DIP Switch #3: Unassigned	13
DIP Switch #4: Unassigned	13

DIP Switch #5: Headlights Supervision.....	13
DIP Switch #6: Arm Alarm.....	13
DIP Switch #7: Automatic Lock/Unlock.....	13
DIP Switch #8: FOB Long Unlock Output Selection	14
DIP Switch #9: FOB Long Unlock Time Selection	14
DIP Switch #10: 3rd Unlock/Staggered Lock	14
DIP Switch #11: Unassigned.....	14
DIP Switch #12: Unassigned.....	14
Additional System Features	14
Light Activation	14
2nd Unlock Output	15
3rd Unlock / Staggered Lock Output	15
2nd Auxiliary Output.....	15
Panic Mode	15
Lock/Unlock Confirmation	15
Starter Kill Feature	15
Vehicle Alarm	15
Lock/Unlock Confirmation Control.....	16
Troubleshooting	17
Appendix: Installation and Mounting e-FOB System.....	I
General Mounting Guidelines:.....	I
Wiring Color Code Tables and Diagrams.....	I
Mating Connector Information.....	I
RF Receiver	II
Typical Wiring Configurations	IV
Wiring Diagram—Lock/Unlock 3-Bank System	IV
Wiring Diagram—Lock/Unlock 2-Bank System	V
Wiring Diagram—Accessory Connections	VI

Introduction

This manual provides the necessary information for the proper installation and use of TriMark's Discrete **e-PAD / e-FOB** System.

The discrete **e-PAD / e-FOB** system includes:

- **e-FOB** (keyless entry radio frequency [RF] FOB transmitter and receiver)
- **e-PAD** or **e-GRAB Handle** (keypad user interface) - Keypad integrated grab handle. **Clean acrylic rod with mild soap and water only.**

The Full-Feature RF receiver and FOB transmitters are shipped programmed. After making all necessary wiring connections (see appendix page IV), the **e-PAD / e-FOB** system will function as indicated in this manual.

TriMark Full-Feature RF Controller



e-GRAB Handle



Keypad — available vertical or horizontal



e-FOB Operation and Features - Standard Mode

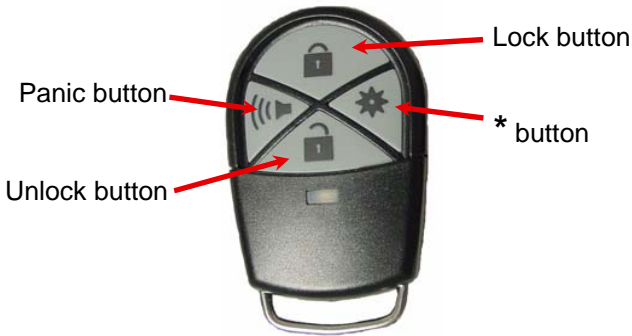

Button	Function
Lock button	Locks all doors and arms security system.
Unlock button	Unlocks doors and disarms security system. Also activates the dome light.
Panic button	Activates panic mode when pressed and held for 2 seconds.
* button	* button function is OEM/dealer defined. Possible assignment include: interior/exterior lighting, awning extension/retraction, gas cap, hood, etc.

Notes:

- While the engine is running only the unlock function of the **e-FOB** remains activated — other functions are deactivated.
- For information on changing the default configuration, see DIP Switch Setting Assignment on page 12.

e-FOB Operation and Features - Cargo Mode

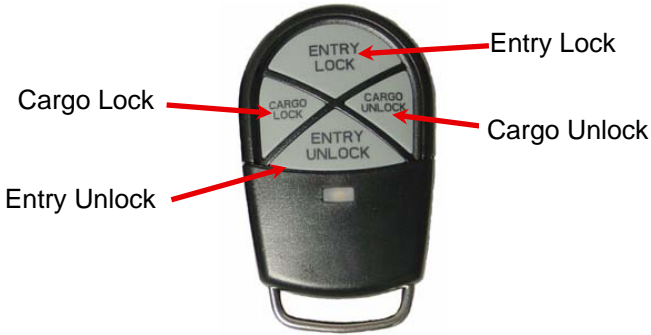

Button	Function
Entry Lock	Locks entry doors and arms security system.
Entry Unlock	Unlocks entry doors and disarms security system. Also activates the porch light.
Cargo Lock	Locks compartment doors and arms security system.
Cargo Unlock	Unlocks compartment doors and disarms security system.

Notes:

- While the engine is running only the entry unlock function of the **e-FOB** remains activated —other functions are deactivated.
- For information on changing the default configuration, see DIP Switch Setting Assignment on page 12.

Standard e-PAD Operation and Features

The e-PAD is shipped with default *Authority* and *Access Codes*. If the OEM or dealer has not changed default codes, the *Authority* and *Access Codes* are:

Access code:

Digit 1	Digit 2	Digit 3	Digit 4	Digit 5
1 / 2	3 / 4	5 / 6	7 / 8	9 / 0

Authority code:

Digit 1	Digit 2	Digit 3	Digit 4	Digit 5
7 / 8	7 / 8	7 / 8	7 / 8	7 / 8



Lock Doors With Keypad

Press and hold down the (1 / 2) button for 1-2 seconds. An access code is not needed to lock the doors.

Using Secure Operations

Entering a valid 5-digit access code provides a double beep and enables a secure operation. After entering an access code, the keypad is enabled for 5 seconds and the next button pressed initiates a secure operation, such as unlocking the doors.

Notes:

- The authority code does not allow for secure operations. It is only used to assign access codes (see page 9 for information on setting authority and access codes).
- If an unassigned button or no button is pressed while the system is enabled, the keypad reverts back to disabled state.
- If keypad does not provide double beep, a valid access code has not been entered.

Available Secure Operations

- Button (1 / 2): Unlock entry doors.
- Button (3 / 4): Unlock doors wired to 2nd Unlock output.
- Button (5 / 6): NA
- Button (7 / 8): Sequentially activate entry unlock and 2nd unlock outputs.
- Button (9 / 0): Toggle dome light output.

Doorbell e-PAD Operation and Features

Access Code:

Digit 1	Digit 2	Digit 3	Digit 4	Digit 5
1	2	3	4	4

Authority Code:

Digit 1	Digit 2	Digit 3	Digit 4	Digit 5
4	4	4	4	4



Lock Doors With Keypad

Press and hold down the (1) button for 1-2 seconds. An access code is not needed to lock the doors.

Door Bell Operation

The doorbell button provides a 0.5 second ground pulse from the 2nd Auxiliary output when pressed. An access code is not necessary for the doorbell. DIP Switch #8 and #9 of the RF receiver must be OFF to provide the correct output.

Using Secure Operations

Entering a valid 5-digit access code provides a double beep and enables a secure operation. After entering an access code, the keypad is enabled for 5 seconds and the next button pressed initiates a secure operation, such as unlocking doors.

Notes:

- The authority code does not allow for secure operations. It is only used to assign access codes (see page 9 for information on setting authority and access codes).
- If an unassigned button or no button is pressed while the system is enabled, the keypad reverts back to disabled state.
- If keypad does not provide double beep, a valid access code has not been entered.

Available Secure Operations

- Button (1): Unlock entry doors.
- Button (2): Unlock doors wired to 2nd Unlock output.
- Button (3): NA
- Button (4): Sequentially activate entry unlock and 2nd unlock outputs.

More e-PAD Features

Protective Deactivating Security Feature

If a correct code is not entered after 20 button presses, the keypad enters an inactive mode that disables button recognition for 1 minute. This helps prevent unauthorized access by entering random codes. There is no button feedback while the system is disabled.

Buzzer Operation

The keypad buzzer chirps once when power is first applied to the keypad and for each key press during regular use. When an authorized access code is entered, the system chirps twice to indicate readiness to secure operation.

The keypad chirps twice for each button press while in learn mode. When a new access code is defined, the system chirps 3 times. If an incorrect code is entered during learn mode, there is a 1-2 second chirp.

Grab Handle Lighting

The acrylic rod LED is powered separately from the keypad. The OEM wiring determines when the rod is lit. The **e-PAD** is lit with a button press and while training new access and authority codes.

Dome Light Activation

The dome light is toggled on for 5 minutes with a secure (9 / 0) operation. Repeating the (9 / 0) operation while the dome light is on will turn the light off.

Emergency Override

To disarm the alarm in case of FOB transmitter and access code loss:

1. Turn ignition on (apply 12V to yellow wire of C1).
2. Press and hold the push button for 3 seconds.
3. Turn ignition off (remove 12V from yellow wire of C1).

Teaching Additional FOB Transmitters

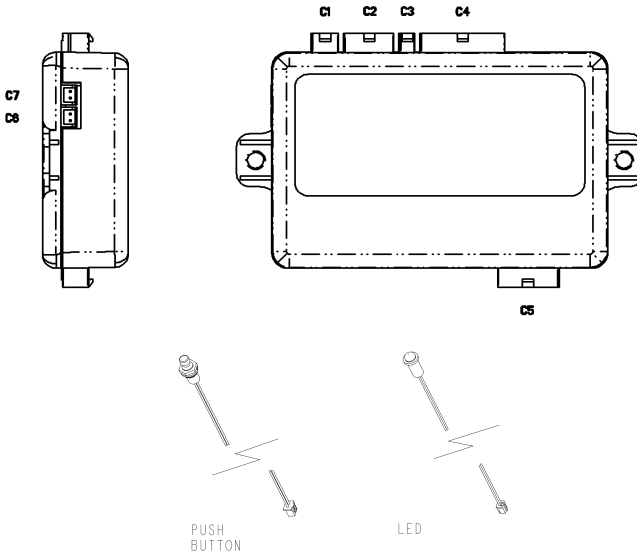

1. Plug the LED into C6 and the push button into C7 on the receiver.
2. Turn ignition off and disarm alarm.
3. Press and release the programming button 3 times. The LED will turn on red after 3 seconds.
4. Press and release the Lock button of each new FOB transmitter once. The LED will flash off and the horn will sound once. Up to 60 transmitters may be programmed at one time.
5. Repeat step 4 until all FOBs are programmed.

Notes:

- If you place the system in learn mode and teach nothing, the system will exit in 10 seconds.
- When new transmitters are taught, all old transmitters are erased.
- The memory for codes will not be erased if power is removed.
- As soon as the LED turns off, the system is fully functional.

Training Wireless Switches

Up to 20 wireless switches can be trained to the RF controller. A wireless switch can provide door ajar information, input from a shock sensor, a motion sensor, a glass break sensor, etc.

1. Plug the LED into C6 and the programming button into C7 on the receiver.
2. Turn ignition off and disarm alarm.
3. Press and release the programming button 5 times. The LED will turn on green after 2 seconds.
4. Press the programming button X number of times to store the wireless sensor in X position (1-25). The LED will briefly flash red.
5. Remove the magnet from the wireless sensor to activate the output. The horn will honk and the siren will sound.
6. Repeat steps 4 and 5 to train additional wireless sensors. If two sensors are trained to the same position, only the second sensor will be active.

Notes:

- As soon as the LED turns off, the system is fully functional.
- The system exits learn mode after 10 seconds of inactivity.
- To erase all wireless sensors, turn ignition on and press the programming button 10 times. The horn and siren will sound once to indicate that all sensors have been erased.
- The memory for codes will not be erased if power is removed.

Teaching Keypad New Authority / Access Codes

IMPORTANT: READ ALL INSTRUCTIONS FOR EACH OPTION AND ALL NOTES **BEFORE BEGINNING** TO KNOW WHAT TO EXPECT DURING THE PROGRAMMING PROCESS.

The *Authority Code* has only one purpose; it grants the owner the ability to set new *Access Codes*. The *Authority Code* must be **EXACTLY 5** digits long. There are two ways to set the *Authority Code* with the TriMark Full Feature System. Changing the *Authority Code* erases all previous *Access Codes* and sets a new *Access Code* in memory bank 1 that is the same as the new *Authority Code*.

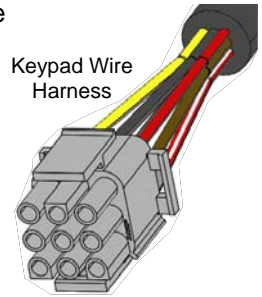

Important: *Authority* and *Access Codes* should be different for the greatest security.

Option 1. Use when you cannot find the RF controller or if the OEM does not fully install the **e-PAD / e-FOB** system.

Preparation:

1. Find the wiring harness coming out of the back of the keypad. This is usually behind the passenger armrest next to the entrance door.

Programming:

2. With the keypad still plugged in, short the yellow wire to ground (a paper clip between the yellow and black wires in the connector works) until the keypad begins to beep.
3. The keypad will beep for 3 seconds; remove the short before the keypad stops beeping. The keypad is now in "Learn Mode."
4. Enter a new 5-digit *Authority Code* (double chirps after each button press). The keypad chirps 3 times after the 5th digit's entry.
5. Re-enter the new *Authority Code* for confirmation. The keypad will chirp FOUR times for successful confirmation. **A long beep indicates a failure to change the code.**
6. Test the new code to confirm it.

Use a jumper or paper clip to temporarily short yellow and black wires together with the keypad still plugged in.

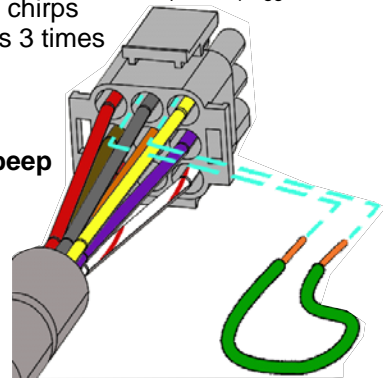

Option 2. Use when you have access to the RF controller and you are certain the OEM has fully hooked up **e-PAD / e-FOB** system (not common).

Preparation:

1. Plug the LED into C6 and the push button into C7 on the receiver (see page 6).
2. Disarm alarm (see emergency override page 6) and turn ignition on (12V at yellow wire of C1).

Programming:

3. Press and release the push button 3 times. Wait 3 seconds. The keypad will beep for 3 seconds. The keypad is now in “Learn Mode”.
4. Enter a new 5-digit *Authority Code*. (Double chirps after each button press). The keypad chirps 3 times after the 5th digit’s entry.
5. Re-enter the new *Authority Code* for confirmation. The keypad will chirp FOUR times after successful confirmation. **A long beep indicates a failure to change the code.**
6. Test the new code to confirm it.

The user is given 2 minutes to complete this procedure. If it isn’t completed in time, or an error is made, the system will exit learn mode and a long chirp will sound to indicate the error.

Notes:

- While in “Learn Mode,” each button push provides a double-chirp and the backlight flashes.
- The authority code is to be controlled by individuals (owners of vehicle, fleet manager, etc.) who manage the distribution of access codes to vehicle users.
- The authority code should be changed when the vehicle is sold.
- The authority code does not enable secure functions (lock/unlock doors, etc.)—it is only used to assign access codes.
- Doorbell systems only allow codes using buttons 1-4 and provides for 4 unique access codes.
- The keypad automatically leaves “Learn Mode” when the new code is set.

The following area can be used to document the *Authority Code*:

Authority Code				
Digit 1	Digit 2	Digit 3	Digit 4	Digit 5

Assign New Access Codes

The *Access Codes* are used for secure functions, such as unlocking doors. The *Access Codes* must be **EXACTLY 5** digits long. With a valid *Authority Code*, an *Access Code* can be programmed with the following instructions:

1. Press the (5 / 6) or (3) button for 5 seconds until the keypad beeps. The backlighting of the keypad will flash indicating the keypad is in "Learn Mode."
2. Enter the 5-digit *Authority Code* (see page 4 for the code).
 - If you enter an **INCORRECT** *Authority Code*, the keypad will beep for 1 second, and leave "Learn Mode."
 - If you enter a **CORRECT** *Authority Code*, the keypad will provide a constant beep that will only stop after you have defined a **memory bank** to store the new *Access Code*.
3. Press and release the button that corresponds to the **memory bank**. For example, press (1 / 2) or (1) button for Memory #1 and press (3 / 4) or (2) button for Memory #2. During this activity you are choosing 1 of 5 (4) memory banks.
4. Enter a new 5-digit *Access Code*. The keypad chirps 3 times after the 5th digit's entry.
5. Re-enter the new *Access Code* for confirmation. The keypad will chirp 3 times after a successful confirmation. A long beep indicates a failure to change the code.
6. Test the new code to confirm a successful change.

Repeat process to assign additional *Access Codes*.

Notes:

- Up to 5 (4) different *Access Codes* can be assigned at any time. As additional *Access Codes* are defined, pre-existing *Access Codes* are overwritten. For example, if a new *Access Code* is assigned to Memory #3, the previous *Access Code* in Memory #3 is no longer valid.
- If an error is made at any point, or if time runs out, the keypad will exit "Learn Mode," provide a 1-2 second beep, and not change anything.

The following area can be used to document the access code assignments:

Memory #	User Name	Digit 1	Digit 2	Digit 3	Digit 4	Digit 5
1/2 (1)						
3/4 (2)						
5/6 (3)						
7/8 (4)						
9/0						

Smart LED:

The smart LED indicates system status:

- Slow flash = Armed
- Off = Disarmed
- Fast flash = Alarm activated

DIP Switch Setting Assignment

The DIP Switch settings control additional functions. Power to the receiver should be disconnected and reconnected after a DIP switch is changed. Down is ON for these switches. Functional assignments are described below:

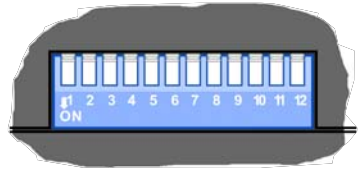

Switch	DIP Switch Settings		
#1	Standard/Cargo Mode	ON = Cargo Mode	OFF = Std. Mode
#2	Left & Right Buttons Output	ON = Sustained	OFF = Pulse
#3	--	--	--
#4	--	--	--
#5	Headlights Supervision	ON = 0.25 sec. Pulse	OFF = 30 sec.
#6	Arm Alarm	ON = 1 Lock Button Press	OFF = 2 lock button presses
#7	Automatic Lock/Unlock	ON = Enabled	OFF = disabled
#8	Keypad #5 output and FOB long unlock	ON = Lights output for 5 minutes	OFF = aux. 2 output for 5 minutes
#9	Keypad #5 Output and FOB long unlock	ON = Output 0.25 sec. pulse	OFF = output on for 5 minutes
#10	3rd Unlock/Staggered Lock	ON = staggered with lock	OFF = activated with unlock
#11	--	--	--
#12	--	--	--

DIP Switch #1: Cargo/Standard Mode

- DIP Switch #1 ON: pressing the Cargo Lock (center left) button pulses the staggered lock output. A Cargo Unlock (center right) button press provides pulses from Auxiliary and 2nd unlock outputs.
- DIP Switch #1 OFF: the Horn button (center left) activates panic mode. Horn, siren, lights, parking lights activate for 30 seconds. The * button (center right) pulses the Auxiliary Output.

DIP Switch #2: Sustained Output

(This switch is ignored unless DIP #1 is OFF)

- DIP switch #2 ON: the center left and right buttons provide sustained outputs. Output lasts as long as the button is pressed –up to 30 seconds.
- DIP Switch #2 OFF: the center left and right buttons provide a pre-set timed pulse.

DIP Switch #3: Unassigned

DIP Switch #4: Unassigned

DIP Switch #5: Headlights Supervision

- DIP switch #5 ON: the headlights flash once with an unlock command.
- DIP switch #5 OFF: the headlights are activated with the dome lights. Lights remain illuminated for 30 seconds with an unlock command. Arming the alarm or starting the car deactivates the lights immediately.

DIP Switch #6: Arm Alarm

- DIP switch #6 ON: a single lock press locks doors and arms the alarm.
- DIP switch #6 OFF: first lock press locks doors. Second lock press arms the alarm.

DIP Switch #7: Automatic Lock/Unlock

- DIP switch #7 ON: the auto-locking feature is activated. All doors are locked 5-seconds after ignition start. Doors unlock when the ignition is turned off. THIS FEATURE IS CANCELED if a door is open when the ignition is started. This protects against accidental locking of keys in the vehicle.
- DIP switch #7 OFF: Automatic lock/unlock feature is disabled.

DIP Switch #8: FOB Long Unlock Output Selection

- DIP switch #8 ON: the #5 keypad output provides a mirrored output to the headlights.
- DIP switch #8 OFF: the #5 keypad output provides a mirrored output to Aux 2.

DIP Switch #9: FOB Long Unlock Time Selection

- DIP switch #9 ON: the keypad #5 output provides a 3 second pulse and FOB long unlock provides a 0.5 second pulse output dependent upon DIP switch #8.
- DIP switch #9 OFF: the keypad #5 output provides a pulse (0.5 second) and FOB long unlock provides a 5 minute output dependent upon DIP switch #8.

DIP Switch #10: 3rd Unlock/Staggered Lock

- DIP switch #10 ON: the 3rd unlock output is staggered to the lock actuation to decrease peak current draw.
- DIP switch #10 OFF: the 3rd unlock output actuates with an unlock command.

DIP Switch #11: Unassigned

DIP Switch #12: Unassigned

Additional System Features

Light Activation

When the alarm is armed, the parking lights flash and horn honks. With an unlock instruction from either the FOB transmitter or keypad; the dome light stays illuminated for 30 seconds. The headlight actuation is controlled by DIP Switch #5 with an unlock instruction. (With lock the headlights pulse once.)

2nd Unlock Output

Press and release the Unlock button on the FOB transmitter twice for a pulse output. Enter secure operation #2 from keypad in standard mode. In cargo mode, the 2nd unlock output occurs with a cargo unlock button press.

3rd Unlock / Staggered Lock Output

The 3rd unlock output is actuated with the unlock command. If DIP switch #10 is on, the 3rd unlock is staggered to the lock output. In cargo mode, staggered lock occurs with a cargo lock button press.

2nd Auxiliary Output

The 2nd Auxiliary output is actuated by pressing the doorbell button on the keypad or holding down the unlock button for 2 seconds. The output is either a pulse output or a 5-minute toggle dependent on DIP switch #9. This is the doorbell feature on the doorbell keypad.

Panic Mode

Pressing and holding the Horn button (center left) for 2 seconds activates panic mode. During panic mode, horn/siren is continuously activated and headlights and parking lights flash for 30 seconds. Pressing the Lock or Unlock button deactivates panic mode.

Lock/Unlock Confirmation

The horn and siren chirp once when the alarm is armed. If the alarm has been set off since the last unlock command, the siren and horn chirp 4 times to indicate the alarm activity when the system is disarmed. The horn and siren chirp twice on unlock. The headlight and parking light outputs pulse once on a lock and unlock.

Starter Kill Feature

The starter kill feature is active for 30 minutes after the alarm is activated. Install a relay controlled by the starter kill feature between the ignition key switch and starter solenoid.

Vehicle Alarm

The alarm is armed when the doors are locked per DIP switch #6. When the alarm is armed, the parking lights flash and the horn/siren chirp. The smart LED flashes continuously.

The alarm is activated with a security trigger input or if the ignition is started. The horn, siren, parking lights and head lights flash for 30 seconds. The starter kill is activated for 30 minutes. Press the Lock or Unlock buttons to deactivate the alarm.

There is a 5 second delay before the system will recognize a security input. If a security input (door ajar switch, motion sensor, glass break sensor, etc.) is triggered while the alarm is armed, the security input must be turned off and then on before the alarm is activated. The horn and siren chirp 3 times if a security input is active when the alarm is armed.

Lock/Unlock Confirmation Control

The siren and horn confirmation is controlled by pressing lock (top button), unlock (bottom button), and auxiliary (*, or center right) buttons at the same time. A single chirp is heard when confirmation is muted. A double chirp occurs when turned on.

Cargo mode: entry lock, entry unlock, cargo unlock.

Troubleshooting

Problem Description	Possible Solution
e-FOB Hints	
Button press does not provide correct operation	Verify power to RF receiver
	Replace FOB transmitter battery
	Re-teach the FOB transmitter to the receiver
No operation or intermittent operation	Move RF receiver away from enclosed metal areas and fully extend antenna
	Check FOB transmitter battery voltage. Batteries need to be changed every 1-2 years depending on usage.
One particular e-FOB function does not work	Check wire connection of affected function at RF module and wiring harness
e-PAD Hints	
No response with button press	Verify connection of keypad.
Access code is not recognized	Verify that code has not been changed. Reassign keypad with instructions on page 8.
	Confirm use of an access code, not the authority code.
Acrylic rod develops surface cracks	A petroleum or alcohol based product was used to clean rod. Only use mild soap and water on rod.
e-ASK System Hints	
Entrance door does not respond to lock/unlock commands	Clean the door contacts and make sure they are not bent, damaged, or improperly aligned.
	If your doorway has a wire harness instead of contact plates in the doorway, make sure the wires are not broken.

This product has been manufactured with methods to ensure high quality and to meet the high expectations of our customers. *TriMark* warrants this product to be free from workmanship defects and will remedy issues per *TriMark's* warranty policy.

Remote transmitter FOBs, batteries, and other equipment subject to normal wear and deterioration may need to be replaced periodically by dealer and/or end user and are not covered by this warranty. *TriMark* will not be liable for indirect, special, incidental or consequential damages.

This system complies with part 15 of the FCC Rules. Operation is subject to the following two conditions:

- (1) This device may not cause harmful interference and
- (2) This device must accept any interference received including interference that may cause undesired operation.

Note: The manufacturer is not responsible for any radio or television interference caused by unauthorized modifications to this equipment. Such modifications could void the user's authority to operate the equipment.

Appendix: Installation and Mounting e-FOB System

Contact TriMark for specific mounting details, such as drawings, placement suggestions, mounting hardware, etc.

General Mounting Guidelines:

The RF receiver should be placed in an interior location that does not shield RF signals. You may need to try multiple locations to optimize reception. The antennae must be left fully extended and exposed. Minimize shielding from metal enclosures.

Mount **e-PAD** grab handle to vehicle with #8 or M4 screws. Connect 12V to the LED with the red wire to +12V and black wire to ground. Keypad harness provides connection between discrete keypad and RF controller.

Wiring Color Code Tables and Diagrams

The following tables and diagrams are provided to show color-coded wire and pin assignments for the **e-FOB** system. Connect all wires before plugging module into wiring harness.

Mating Connector Information

C1	Power input:	Amp 106527-4 (4-pin)
C2	Keypad input:	Amp 106527-8 (8-pin)
C3	Lock/Unlock input:	Amp 106527-2 (2-pin)
C4	Non-relay output:	Amp 1-106527-4 (14-pin)
C5	Relay output:	Amp 1-106527-0 (10-pin)

Terminals: Amp 106529-2 for 18-22 AWG wire
 Amp 794418-1 for 16 AWG wire



RF Receiver

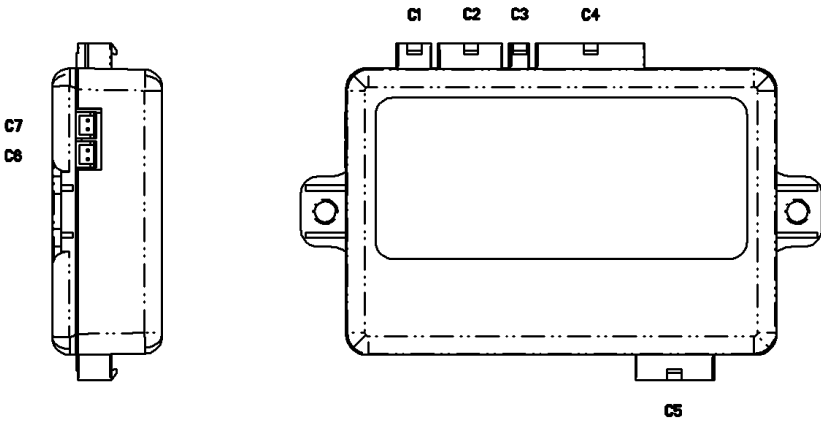

Wire Colors	CONNECTOR 1: 4-PIN HARNESS	
--	--	1
Yellow	Ignition Input	2
Black	Ground Input	3
Red	Power (+12V)	4
Wire Colors	CONNECTOR 2: KEYPAD HARNESS	
Black	System Ground	1
Purple	Lights/Doorbell Output	2
Brown	3/4 (2) Secure Operation	3
White/Green	Lock All	4
Red	System Power (12V)	5
Yellow	Learn Mode (GND to enter)	6
--	--	7
White/Red	1/2 (1) Secure Operation (unlock entry)	8
Wire Colors	CONNECTOR 3: 2-PIN HARNESS	
Green/White	Lock Input (-)	1
Blue/White	Unlock Input (-)	2



Wire Colors	CONNECTOR 4: 14-PIN HARNESS	
White/Purple	(-) Security Trigger Input 3	1
Orange	Armed Output (-500 mA)	2
Brown	Starter Kill Output (-500 mA)	3
Gray	Lights Output (-500 mA)	4
Brown/White	Horn Output (-500 mA)	5
White/Black	(-) Security Trigger Input 1	6
White/Yellow	Siren Output (A/C)	7
Red/White	Aux. 2 Output (-500 mA)	8
Black /White	Aux. Output (relay 15A)	9
White/Orange	2nd Unlock Output (-500 mA)	10
White/Blue	3rd Unlock/Staggered Lock (-500mA)	11
White	Parking Lights (relay 15A)	12
White/Red	(+)Security Trigger Input 2	13
Light Green	Siren Output (A/C)	14
Wire Colors	CONNECTOR 5: 10-PIN HARNESS	
Green/Black	Door Lock (N/C) (relay 30A)	1
--	--	2
Purple	Dome Light Output (relay 15A)	3
Pink	Dome Light (N/O) (relay 15A)	4
Pink/Black	Dome Light (N/C) (relay 15A)	5
Green/White	Door Lock (N/O) (relay 30A)	6
Green	Lock Output (relay 30A)	7
Blue/Black	Door Unlock (N/C) (relay 30A)	8
Blue/White	Door Unlock (N/O) (relay 30A)	9
Blue	Unlock Output (relay 30A)	10

* DO NOT USE A TEST LIGHT ON THE MODULE'S 500MA OUTPUTS



Typical Wiring Configurations

Wiring Diagram - Lock/Unlock 3-Bank System

Notes:

Additional door actuators can be installed in parallel on each bank (i.e. connecting all blue wires together on every relay on the same bank) as appropriate based on amp draw from actuators and amp rating on relays

If amp draw from actuators exceeds the rating of the relay, add an additional relay in parallel (I.E. Connect C4-Pin10 to the 86 terminal of an additional relay for more Bank 2 capacity)

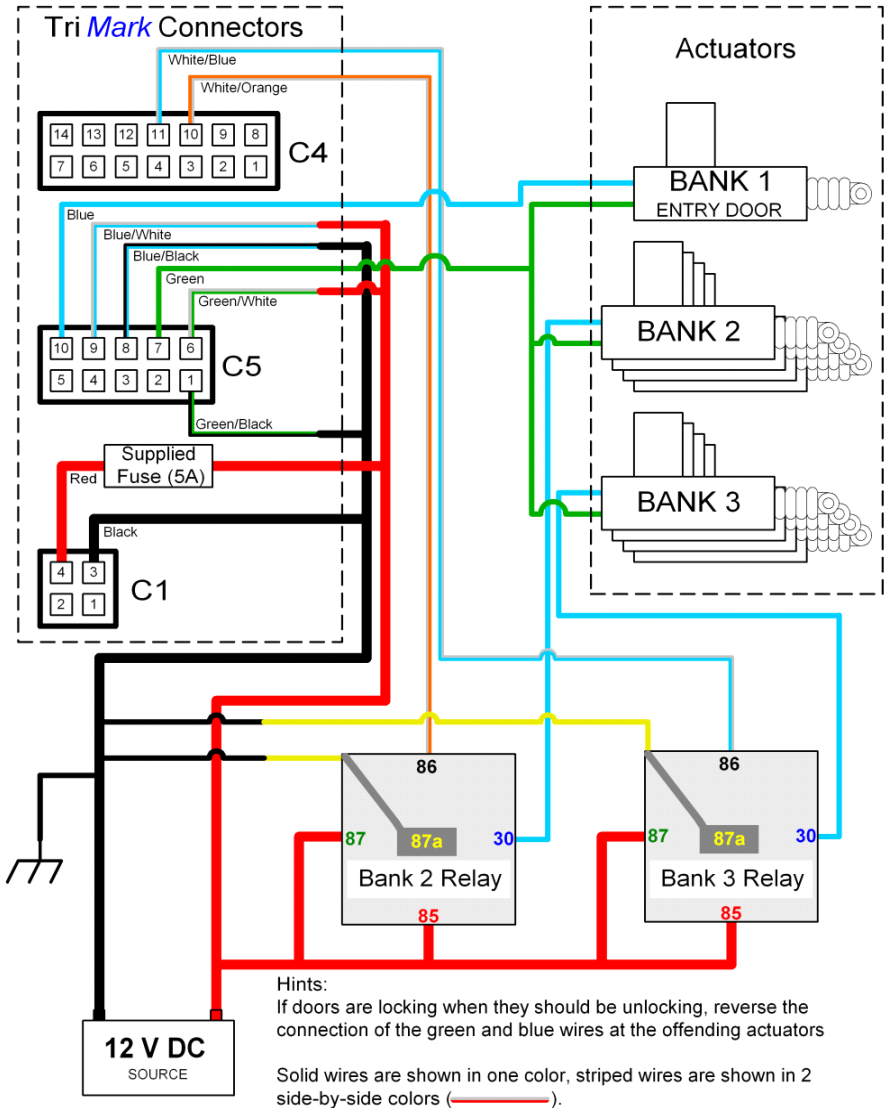

Wiring Diagram - Lock/Unlock 2-Bank Staggered/Cargo System

Notes:

Additional door actuators can be installed in parallel on each bank (i.e. connecting all blue wires together on every relay on the same bank) as appropriate based on amp draw from actuators and amp rating on relays

If amp draw from actuators exceeds the rating of the relay, add an additional relay in parallel (I.E. Connect C4-Pin10 and C4-Pin11 to the 86 terminal of an additional relay pair for more Bank 2 capacity)

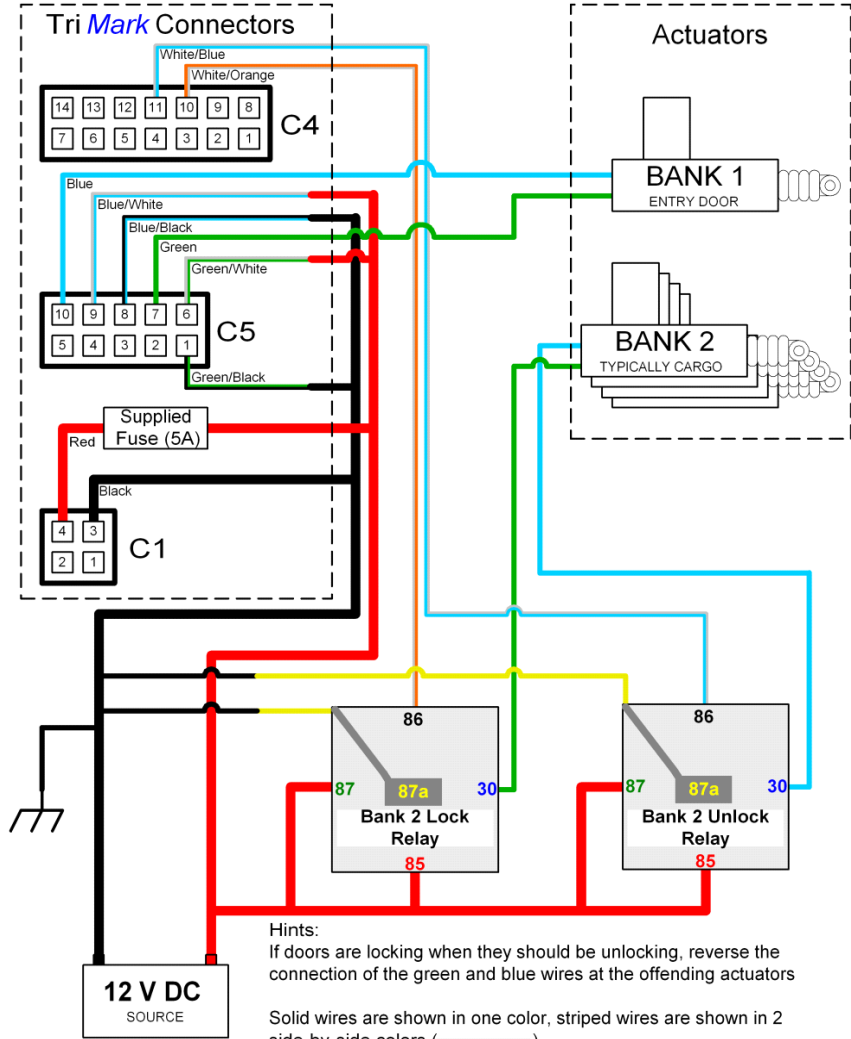

Hints:
If doors are locking when they should be unlocking, reverse the connection of the green and blue wires at the offending actuators

Solid wires are shown in one color, striped wires are shown in 2 side-by-side colors ().



Wiring Diagram - Accessory Connections

Notes:

Connectors are shown oriented with the locking tab on top and the wires toward the reader.

All accessory connections are optional, and are not necessary for locking/unlocking operations to function.

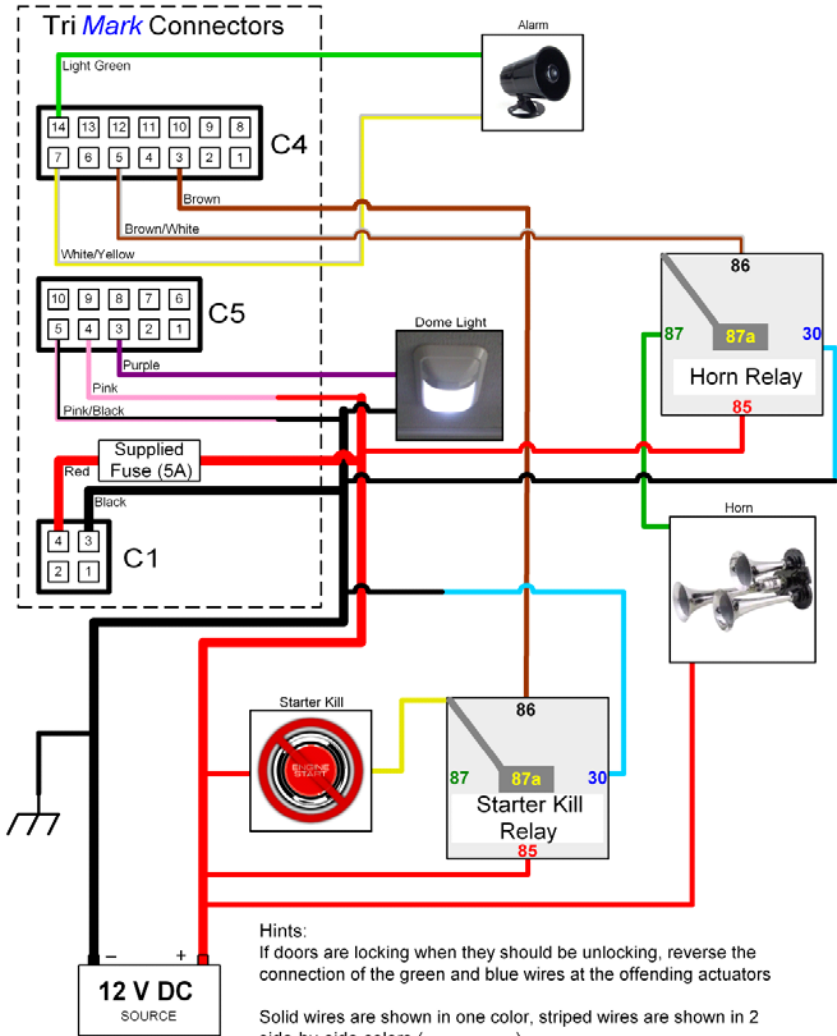



500 Bailey Avenue
P.O. Box 350
New Hampton, Iowa 50659 U.S.A.
Tel: 641-394-3188
Fax: 641-394-2392
www.trimarkcorp.com

UM17
22271-03
04/12-4