

500-1200 e-ASK System (Electronic Access and Security Keyless-entry)



TriMark's e-ASK systems consist of a selection of compatible components that allow for complete keyless entry for on or off-highway vehicle applications

Designed for:

- Incorporation into TriMark mechanical latches, handles and systems by providing keyless entry, security and convenience for access door systems through a RF remote fob electronics interface



TriMark Corporation
500 Bailey Avenue
P.O. Box 350
New Hampton, Iowa 50659
United States
Tel: 641-394-3188
Fax: 641-394-2392
1-800-447-0343
www.trimarkcorp.com

10002707 QM08
10002707 TS09



ISO 9001: 2008
ISO/TS 16949: 2009

TriMark Corporation

TriMark Europe
Cedar Court
Walker Road
Bardon Hill
Coalville LE67 1TU
United Kingdom
Tel: +55 (0)1530 512460
Fax: +44(0)1530 512461
www.trimarkeu.com

427961 QM08
427961 UM



ISO 9001 : 2008
ISO 14001 : 2004

TriMark Europe Ltd.

Features/Benefits:

- Keyless-entry security and convenience for access door systems through an electrical interface that includes both a touch pad and remote fob transmitter for the ultimate in end user convenience and functionality
- Easy and intuitive to operate
- Rugged and durable construction
- Compliant to on-road, off-road, and industrial environmental requirements
- Increased vehicle security with multiple triggers and outputs
- I/O module with on-board locking and unlocking relays
- Can control up to 20 entry/compartments doors (expandable)
- Independent control of multiple door zones
- Staggered door control for minimized current draw
- J1939 or RV-C communications
- Locking/unlocking confirmation
- Ignition controlled auto-locking
- Starter deactivation available for increased security
- Lighting and auxiliary output control
- Ability to provide 4 OEM definable functions from keypad, including ability to unlock one side of motor home baggage doors at a time
- 3 security system inputs (ability to sense entry door(s) and baggage door(s), and other security system devices such as glass break and motion detectors)
- Variable timed light activation output (porch, compartment or interior lighting)

e-FOB

- Reliable radio frequency (RF) transmission
- High security with code hopping technology
- Compliant to FCC-Part 15 and EU RF requirements
- 4-button standard fob (other configurations available)
- Customized graphics possible (buttons and logos)
- Can add up to 4 fob transmitters to vehicle

Available:

- Standard kit make up includes: keypad, 2 pre-trained RF remote fob transmitters, IO module, gasket, and assembly key rings and manual
- Optional kits can include: any wiring harnesses for all connection points of system, extra relays, switches, door contacts, actuators, mounting hardware, mounting brackets, door latches, and door paddle handles
- Fob transmitters with independent entry and compartment control
- Fob transmitter with control of auxiliary features
- Vertical and horizontal keypad
- Customized wire harnesses
- Additional fob transmitters
- 2 different programming functions; standard mode, and cargo mode. Modes provide customized remote fob transmitter use. Standard mode allows for the lock/unlocking of doors plus panic mode and one auxiliary output (controls lighting, opens compartment etc.). Cargo mode allows for the lock/unlocking of main personnel doors plus independent control of many cargo/compartments doors.

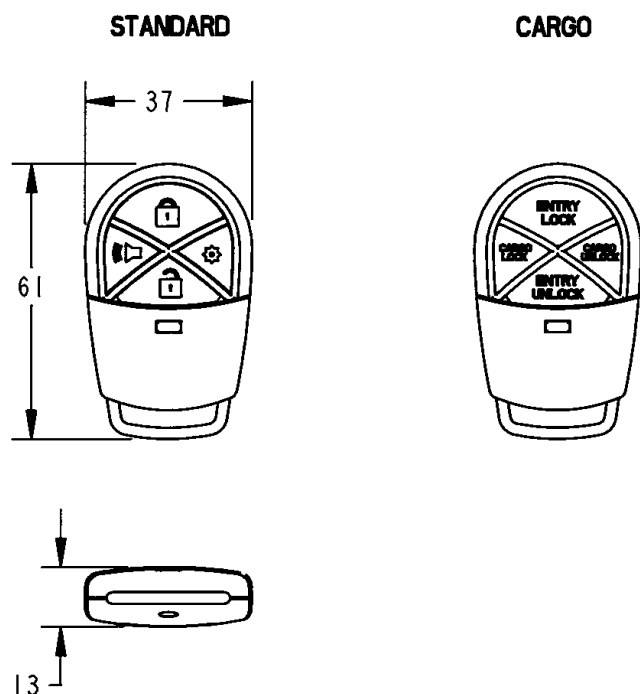

Use With:

Mechanical

- TriMark 030-0175 Stamped Steel Compartment Latch
- TriMark 030-0185 Stamped Steel 2-Point Paddle Handle
- TriMark 030-0400 Paddle Handle
- TriMark 030-0425 Inside Bezel & Release Lever Assembly
- TriMark 030-0450 2-Point Paddle Handle
- TriMark 030-0850 Flush Mounted Paddle Handle
- TriMark 030-0860 Flush Mounted Paddle Handle With Inside Lock Knob
- TriMark 030-0900 Motor Home Entrance Door Hardware With Dead Bolt
- TriMark 030-1100 2-Point Paddle Handle
- TriMark 030-2000 2-Point Free Float Baggage Lock
- TriMark 050-0250 Single Rotor Latch & Linkage Assembly

For more information visit:
www.trimarkcorp.com

Electronic Products and Accessories

- TriMark 550-0100 Power Actuators
- TriMark 550-0200 Solenoids
- TriMark 590-0100 Wire Harnesses
- TriMark 590-0200 Door Contacts
- TriMark 590-0300 Relays
- TriMark 590-0400 Sirens
- TriMark 590-0500 Rocker Switches
- TriMark 590-0600 Plunger Switches
- TriMark supplied or existing OEM security system components (e.g. motion detectors, door-ajar detectors, glass break sensors)

U.S. Patent No. 7,034,655

U.S. Patent No. 7,119,709

Please refer to individual product codes and part drawings for complete dimensions, specifications, and installation procedures. Engineering assistance and application drawings are available.

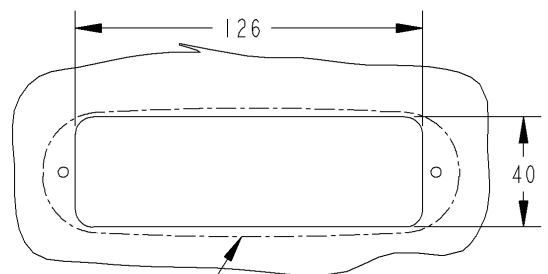
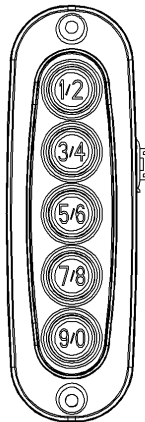
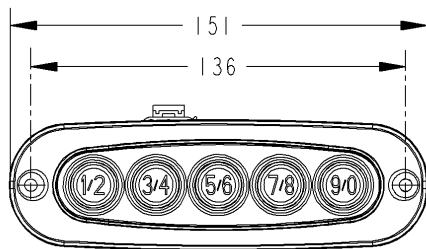

OUTER PERIMETER OF
KEYPAD ASSEMBLY

RECOMMENDED KEYPAD
CLEARANCE CUTOUT

e-PAD

- Tactical, visual, and audio feedback
- Over 3000 code combinations with tamper lock-out features
- Lighted keypad for more effective night time usage
- Vertical and horizontal orientations
- 5 user codes can be assigned
- Multiple layer code control
- Multiple keypads integration

Installation:

- I/O module is easily installed with (4) 1/4" or M6 screws (not included) and can be mounted in a concealed location
- Keypad is easy to install with (2) #8 or M4 flat head screws (not included)
- Keypad can be installed in a wide range of locations in door — either horizontal or vertical orientation
- Standard 12 VDC power
- Easy to install and program

