



## TRT-40x-TDxW-C and TRT-40x-TDxW-F Model Operation

### Layout

The TRT-40x-TDxW-x models consist of 8 lamps. All eight lamps are Color/White lamps. See Figure 1.

### Wiring

#### Control Cable

Activating the Lightbar is done by applying +Vdc to one or more of the lightbar control wires. The control wires consume only a few milliamps of current and can be used with virtually any on/off switch. There are five control wires in the Control Cable plus one +Vdc supply feed.

The control wires are color coded and control the functions shown below.

- Orange wire - Steady Burn on White lamps
- Blue wire - Warning Patterns on Color lamps
- Brown/White wire - Traffic Direction Patterns on Color lamps
- Brown wire - Traffic Direction Patterns on Color lamps
- Green wire - DIM Function
- Red/White wire - +Vdc

Orange Wire – Activates Steady Burn on the white lamps. See Figure 1.

Blue Wire – Activates the Warning patterns on the color lamps. See Figure 1.

Brown/White Wire – Activates the Traffic Direction patterns using the color lamps. See Figure 1.

Brown Wire – Activates the Traffic Direction patterns using the color lamps. See Figure 1.

Green Wire – Activates the low intensity or dim setting.

Red/White Wire – In all lightbars the Red/White wire is a +Vdc feed that can be used to power one or more switches.

The priority of the functions, from highest to lowest, are:

- DIM Function (Green wire)
- Steady Burn White Lamps (Orange wire)
- Traffic Direction Patterns on Color Lamps (Brown wire)
- Traffic Direction Patterns on Color Lamps (Brown/White wire)
- Warning Patterns on Color lamps (Blue wire)



## Warning Mode Lamp Flash Patterns:

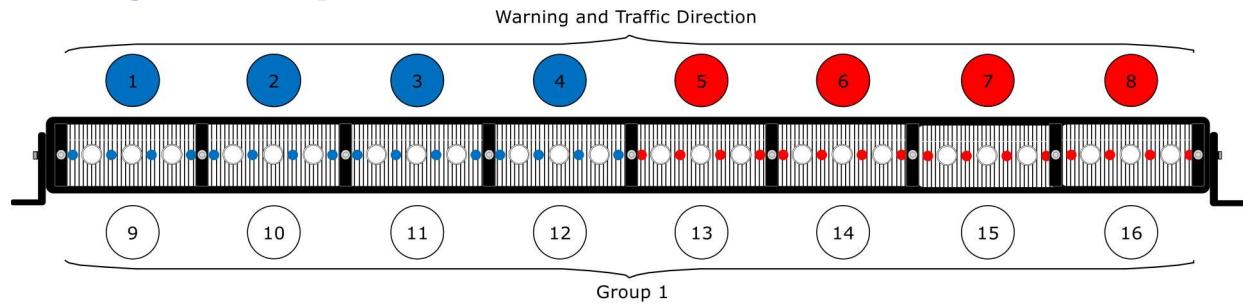

Figure 1 TRT-40x-TDxW-x (Blue/White and Red/White lamps used for illustration only, they could be any Color/White lamps.)

### Available Warning Flash Patterns and Rates:

#### Patterns

- |     |  |  |
|-----|--|--|
| 1)  | OFF                                      |  |
| 2)  | COMBINATION A (Patterns: 6,5,7,5 repeat) | *** <b>DEFAULT BLUE WIRE, SCROLL FLASH</b> |
| 3)  | COMBINATION B (Patterns: 6,5,4,5 repeat) |  |
| 4)  | INBOARD/OUTBOARD                         | Lamps 1, 2, 7 & 8, then lamps 3 - 6        |
| 5)  | LEFT/RIGHT                               | Lamps 1 - 4, then lamps 5 - 8              |
| 6)  | ALTERNATE                                | Lamps 1, 3, 5 & 7, then lamps 2, 4, 6 & 8  |
| 7)  | RANDOM                                   | Lamps 1 - 8                                |
| 8)  | SINGLE OUTBOARD                          | Lamp 1, then lamp 8                        |
| 9)  | DOUBLE OUTBOARD                          | Lamps 1 & 2, then lamps 7 & 8              |
| 10) | SINGLE INBOARD                           | Lamp 4, then lamp 5                        |
| 11) | DOUBLE INBOARD                           | Lamps 3 & 4, then lamps 5 & 6              |
| 12) | TRIPLE INBOARD                           | Lamps 2 - 4, then lamps 5 - 7              |
| 13) | SWEEP                                    | Lamps 1 - 8                                |

#### Rates

- |              |                       |                              |
|--------------|-----------------------|------------------------------|
| 1) Single    | 312 FPM               |                              |
| 2) Double    | 117 FPM               |                              |
| 3) Neobe     | 77 FPM                |                              |
| 4) Single CA | 75 FPM                |                              |
| 5) Scroll A  | (Rates: 1,2,3 repeat) | *** <b>DEFAULT BLUE WIRE</b> |
| 6) Scroll B  | (Rates: 4,2,3 repeat) |                              |



### *Available Traffic Direction Flash Patterns and Rates:*

#### Patterns

- 1) FULL FILL      **\*\*\* DEFAULT BROWN WIRE, DEFAULT BROWN/WHITE WIRE**
- 2) FULL TRAIL
- 3) REDUCED FILL, WARNING OFF
- 4) REDUCED TRAIL, WARNING OFF
- 5) REDUCED FILL, WARNING (SINGLE OUTBOARD) ALTERNATING
- 6) REDUCED TRAIL, WARNING (SINGLE OUTBOARD) ALTERNATING
- 7) REDUCED FILL, WARNING (SINGLE OUTBOARD) SIMULTANEOUS
- 8) REDUCED TRAIL, WARNING (SINGLE OUTBOARD) SIMULTANEOUS

#### Rates

- 1) Single      96 FPM      **\*\*\* DEFAULT BROWN WIRE,  
DEFAULT BROWN/WHITE WIRE**
- 2) Double      125 FPM
- 3) Neobe      96 FPM
- 4) Single CA      75 FPM
- 5) Scroll A      (Two passes of each rate: 1,2,3, repeat)
- 6) Scroll B      (Two passes of each rate: 4,2,3 repeat)



### *Changing Patterns and Rates:*

#### To Enter Programming Mode:

- 1) All Inputs Open, apply Power and ground to the lightbar.
- 2) Green wire connected to +V.
- 3) Wait at least one second, Double Tap the Orange wire to +V. All the lamps should flash 3 times to indicate you've entered Programming Mode.
- 4a) To modify the Warning Pattern and Rate, connect the Blue wire to +V. The lamps should start flashing the currently selected pattern and rate.
- 4b) To modify the Traffic Direction Pattern and Rate, connect the Brown, and/or Brown/White wires to +V. The lamps should start flashing the currently selected pattern and rate.

Note: The Double Tap of the Orange wire must occur within 4 seconds of connecting the Green wire to +V, otherwise the lightbar will NOT enter Program Mode and will operate normally.

Note: Selection of the Traffic Direction mode will take precedence over the selection of the Warning mode.

#### To change the Flash Pattern:

- 1) With a Warning or Traffic Direction mode selected, the Green wire must be connected to +V.
- 2) Tap the Orange wire to +V to step forward through the patterns.

#### To change the Flash Rate:

- 1) With a Warning or Traffic Direction mode selected, disconnect the Green wire from +V.
- 2) Tap the Orange wire to +V to step forward through the flash rates.
- 3) When finished selecting a Flash Rate, connect the Green wire to +V before switching to another Warning or Traffic Direction mode.

Note: Do not switch between changing the Flash Pattern or changing the Flash Rate without a Warning or Traffic Direction mode being selected.

Note: While in Program mode, if at any time, all five wires are disconnected from +V, the controller will exit Program Mode and turn off.



### Wire Runs

The table below lists the maximum recommended wire run for the power and ground cables in feet. The control cable can be the same length as the power cables but 20 gauge wire is sufficient in all cases.

Part Number	Lamps	WIRE GAUGE					
		18	16	14	12	10	8
TRT-03	1	89	142	225	361	575	914
TRT-06	1	51	81	129	206	328	522
TRT-10	2	25	40	64	103	164	261
TRT-15	3		27	42	68	108	174
TRT-20	4		20	31	50	82	130
TRT-25	5		16	25	41	65	104
TRT-30	6			21	34	54	86
TRT-35	7			18	29	46	74
TRT-40	8				25	41	65
TRT-45	9				22	36	57
TRT-50	10					32	52
TRT-60	12					27	43

### Common Switch Wiring Configuration

Wire colors/groups on product may differ from diagram.

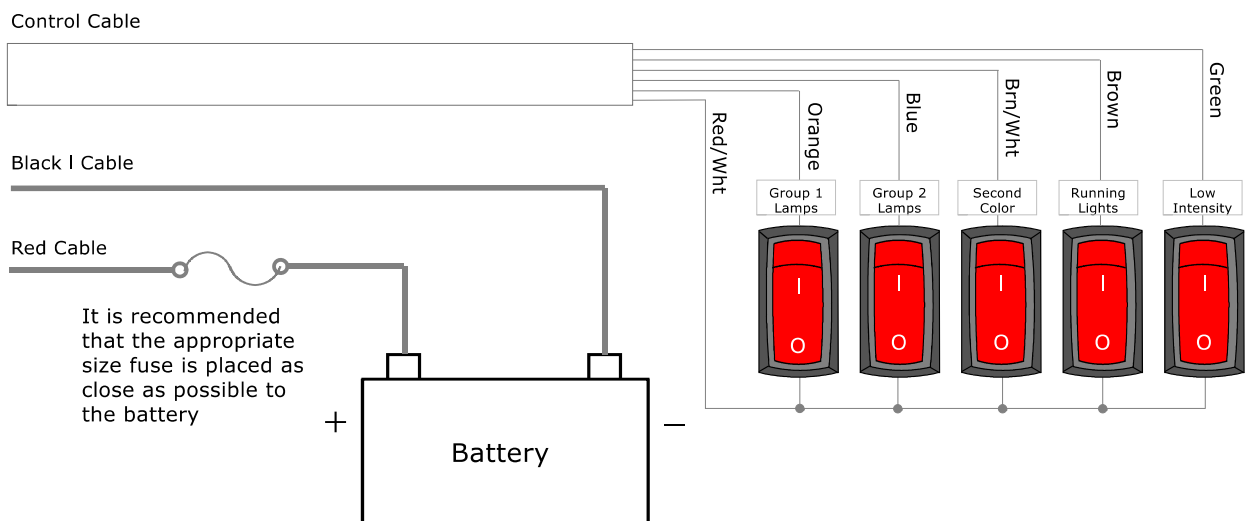



## Mounting

TRT lightbars include an L shape mounting brackets designed to secure the lightbar to a flat surface. The bracket will allow a 135° range of motion. For additional mounting options visit [www.tomaroffroad.com](http://www.tomaroffroad.com).

1. Attach the mounting foot to the lightbar using the 1/4 -20 socket head screws and 1/4" flat washers included with the lightbar, leaving the screws finger tight.
2. Place the lightbar with attached mounting feet on a flat surface that has sufficient strength to support its weight. Using the holes in the mounting brackets as a template mark the location of the mounting holes. The mounting holes in the bracket are designed to free fit 1/4 inch hardware. Recommended drill sizes for 1/4" hardware are 17/64" for clearance holes and 13/64 for taped holes. Note: the hole pattern on the foot is on 2" centers. For the hole spacing between the mounting feet refer to the Dimensions section below.
3. Once the lightbar is secured to the mounting surface, adjust the lightbar to the desired angle and tighten the 1/4-20 socket head screws to approx. 36 in/lb.





## Dimensions

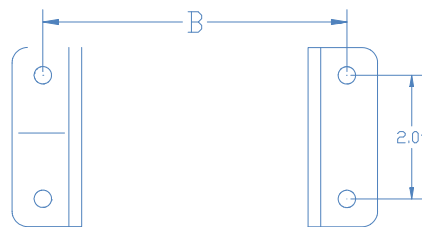
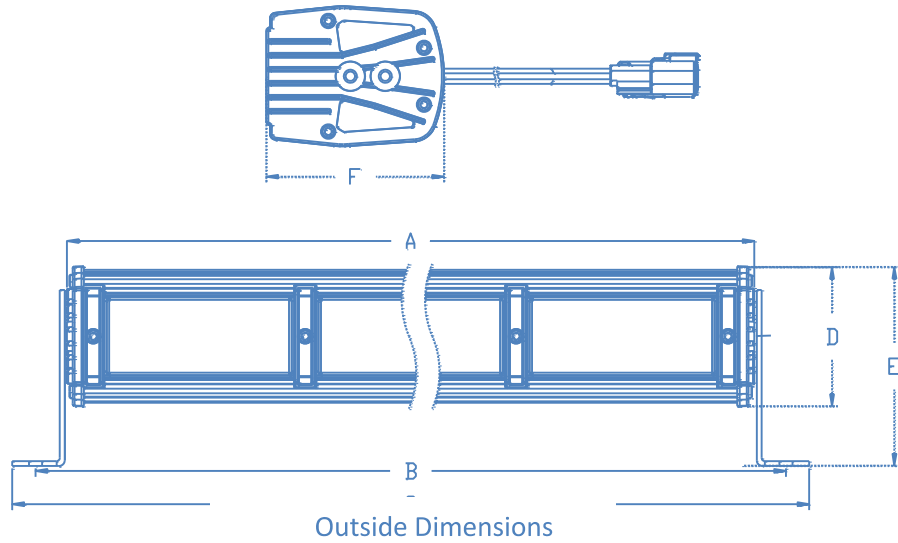

Mounting Hole Spacing

Nominal Length	Lamps	Dim "A"	Dim "B"	Dim "C"	Dim "D"	Dim "E"	Dim "F"
3	1	3.41	4.66	5.66	3.00	4.25	3.82
6	1	5.68	6.93	7.93	3.00	4.25	3.82
10	2	10.23	11.48	12.48	3.00	4.25	3.82
15	3	14.78	16.03	17.03	3.00	4.25	3.82
20	4	19.33	20.58	21.58	3.00	4.25	3.82
25	5	23.88	25.13	26.13	3.00	4.25	3.82
30	6	28.43	29.68	30.68	3.00	4.25	3.82
35	7	32.98	34.23	35.23	3.00	4.25	3.82
40	8	37.53	38.78	39.78	3.00	4.25	3.82
45	9	42.08	43.33	44.33	3.00	4.25	3.82
50	10	46.63	47.88	48.88	3.00	4.25	3.82
60	12	55.73	56.98	57.98	3.00	4.25	3.82



## *Recommended Fuse/Breaker Sizing*

Part Number	Lamps	Amp draw @13.8Vdc	Fuse/Breaker Size (A)
TRT-03	1	1.3	3
TRT-06	1	2.1	5
TRT-10	2	4.2	10
TRT-15	3	6.3	12
TRT-20	4	8.4	15
TRT-25	5	10.5	20
TRT-30	6	12.6	25
TRT-35	7	14.7	30
TRT-40	8	16.8	35
TRT-45	9	18.9	40
TRT-50	10	21.0	45
TRT-60	12	25.2	50

## *Replacing a lamp module*

All TRT lamp modules are interchangeable and can be used in any position on the lightbar. This offers the flexibility to configure a lightbar for any mission with perfect balance of flood, spot or dual color amber white modules. Keep in mind that only the outboard positions will have flash patterns.

With this modular design the replacement of a TRT Lamp couldn't be easier. Each module is hermetically sealed so replacement will not compromise the watertight integrity of the lightbar or void the warranty.

To replace a lamp module simply remove the two lamp clips using a 9/64" hex tool. Unplug the lamp from the waterproof connector, plug in the new lamp and reattach the lamp clips.







## Maintenance

The best cleaning method is to gently wash the lightbar with a solution of mild soap and lukewarm water, using a soft cloth or sponge to loosen any dirt or grime. Thoroughly rinse with clean water to remove any cleaner residue and dry the surface with a soft cloth to prevent water spotting.

If using a high-pressure water cleaner and/or a steam cleaner the pressure should not exceed 1,450psi. The use of additives to the water and/or steam should also be avoided.

### *Important Considerations for Lexan lenses:*

- Never use abrasive or highly alkaline cleaners.
- Never use aromatic or halogenated solvents like toluene, benzene, gasoline, acetone or carbon tetrachloride.
- Contact with harsh solvents such as methyl ethyl ketone (MEK) or hydrochloric acid can result in surface degradation and possible crazing.
- Never scrub lenses with brushes, steel wool or other abrasive materials.