



Model LM1010-2X Performance "R"

MODEL LM1010-2X MECHANICAL SHEAR OPERATION, PARTS & MAINTENANCE MANUAL

Model:	Purchased From:
Serial #:	Date Received:

USA  MADE

6926 Smithville Hwy., McMinnville, TN 37110
931-934-2211 / Fax: 931-934-2220
www.tennsmith.com

TABLE OF CONTENTS

<u>SUBJECT</u>	<u>PAGE NUMBERS</u>
SHEAR SPECIFICATIONS	3
WARRANTY INFORMATION	3
SAFETY LABELING AND INSTUCTIONS	4 - 9
INSTALLATION	10
OPERATING INSTRUCTIONS	11 - 13
BLADE CLEARANCE/ADJUSTMENT	14
BLADE ROTATION/REPLACING	15 - 16
BACKGAUGE INFORMATION	16
HOLDDOWN INFORMATION	17
SHEET SUPPORT SYSTEM INFORMATION	18
MAINTENANCE	19 - 20
PARTS VIEW AND DESCRIPTIONS	21 - 34
ELECTRICAL DIAGRAM AND PARTS LIST	35 - 47



LM SERIES SHEAR	LM1010-2X
Maximum Shearing Capacity, Mild Steel Mild Steel Rated Materials at 80,000 Tensile / 44,000 Yield	10 gauge / 3,5mm
Maximum Shearing Capacity, Stainless Steel Stainless Shear Rated Materials at 90,000 Tensile / 55,000 Yield	14 gauge / 2,0mm
Maximum Cutting Length	121 in / 3073mm
Back gauge Range	30 in / 762mm
Strokes per Minute	35
Number of Hold downs	16
Motor-230/460v, 3-phase, 60Hz	12.5 hp
Overall Dimensions, Less Gauges, LxWxH	145 x 39 x 60 in
Floor Space, Gauges in Position	145 x 78 x 60 in
Shipping Weight	9,500 lbs.

3-YEAR LIMITED WARRANTY

TENNSMITH machinery and component parts are carefully inspected at various stages of production and are tested and inspected prior to shipment. We agree that for a period of twelve (12) months from the date of delivery from our authorized distributor to replace, at our option, any machine (or component part thereof) proving defective within the above period. Additionally, we agree that for a period of thirty-six (36) months from date of delivery to replace component parts proving defective within the stated period. All warranty claims are made F.O.B. our plant, providing such machine (or component part) is returned freight prepaid to our plant, or a designated service center of the undersigned, for our examination. This warranty does not include repair or replacement required because of misuse, abuse, or because of normal wear and tear; or electrical components which are warranty by their manufacturer. Further, we cannot be responsible for the cost of repairs made or attempted outside our factory or designated service center without our authorization. No claims for defects will be honored if the name and data plate has been removed. This warranty is made expressly in place of all other warranties or guarantees express or implied, with respect to fitness, merchantability, quality or operative ness. This warranty becomes effective only when the accompanying warranty card is fully and properly filled out returned to the factory within ten (10) days from date of delivery.

ATTENTION

Please verify that the following safety decals are attached to the LM Shear. If you do not locate all of the decals, please contact Tennsmith to replace any missing or unreadable safety labels.

NEVER operate this machine without the proper safety labeling.





 WARNING	
	
CRUSH AND SHEAR HAZARD Keep clear of rear of the machine during operation. Keep hands away from blades.	



WARNING

TO PREVENT SERIOUS BODILY INJURY

NEVER PLACE ANY PART OF YOUR BODY UNDER THE RAM, HOLD-DOWN FEET, BETWEEN BLADES, BEYOND GUARDS OR AWARENESS BARRIERS UNLESS THE POWER IS OFF AND THE RAM IS BLOCKED UP.

NEVER PLACE HANDS UNDER MATERIAL BEING SHEARED OR OPERATE WITHOUT FIRST MAKING CERTAIN NO PERSON IS BEHIND THE SHEAR.

NEVER OPERATE OR MAINTAIN THIS SHEAR WITHOUT PROPER INSTRUCTION AND WITHOUT FIRST READING AND UNDERSTANDING THE OPERATORS OR SHEAR MANUAL.

IT IS THE EMPLOYER'S RESPONSIBILITY TO IMPLEMENT THE ABOVE AND MAINTAIN ALL GUARDS, BARRIERS, AND DEVICES IN PLACE AND IN PROPER WORKING ORDER.

DO NOT REMOVE THIS SIGN FROM THIS SHEAR

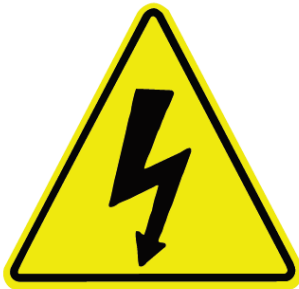

DANGER

Hazardous voltage.

Contact may cause electric shock or burn.

Turn off and lock-out system power before servicing.

SAFETY INSTRUCTIONS

- 1. Read and understand instruction manual before operating, servicing, or maintenance of machine.**
- 2. Do not use machine beyond specified capacity.**
- 3. Keep hands and fingers clear of cutting blade.**
- 4. Never place any part of body between cross head and table.**
- 5. Do not adjust back gauge while cutting material.**
- 6. Never leave the machine running when it is unattended.**
- 7. Provide all proper protective devices and guards that may be necessary or advisable for any particular use, operation, set-up, or service.**
- 8. Report any equipment malfunction to your supervisor.**
- 9. DO NOT REMOVE THIS INSTRUCTION SIGN.**

SAFETY INSTRUCTIONS

1. Do not operate service or perform maintenance prior to reading and understanding the instruction manual. Become familiar with and understand the hazards and limitations of your shear.



2. Wear approved eye protection and protective footwear while operating the machine.
3. Be certain this machine is properly wired and grounded to conform to the National Electric Code. The connection of this machine to the power source should only be made by and inspected by a qualified electrician.



4. Keep hands and body parts clear of the hold down, cutter head and blade area.



5. Do not exceed the rated capacity of the machine.
6. Never leave the machine in a power on condition when unattended.
7. Always disconnect the machine from the power source before attempting maintenance, repairs or adjustments.



8. **DANGER!** Do not attempt to remove the hold down before inserting and bottoming out the hold down compression bolts (71). The compression bolts were shipped with the machine. When receiving the shear the bolts are located inside of the electrical box. Please remove them and store them in a location to be accessible.
9. Do not remove guards unless required to service the machine. Replace all protective covers prior to operation.
10. Always wear gloves to protect your hands when handling the shear blades.
11. Insure that the point of operation safeguarding is provided, used and maintained for any applicable use or service which exposes bodily hazards. For more details please refer the ANSI Standards for Shear Operations.
12. Keep the Work area around this machine clear and clean to avoid tripping or slipping.

INSTALLING THE SHEAR

The unit is shipped with a lifting bolt attached on the top of the cutter head. The shear should be lifted and positioned by using a sling or chain passed through the lifting bolt.

CAUTION! The LM1010 shear weighs approximately 10,000 lbs. net. Be sure to verify the maximum load permissible for a given chain or sling.

Locate the machine in a well lighted area on a solid level floor. Use lag screws or bolts with expandable shields or similar holding devices through the mounting holes on each of the unit's side panels (22,51) The center line dimensions for the foundation holes can be found on the diagram supplied with the manual on page ().

The shear must be securely anchored to the floor and leveled before operating. Check the level of the shear with a machinist level both along the length and depth of the machine. Use the leveling screws (35) provided with the machine to achieve proper level. It may be advisable to slip a small section of light gauge sheet metal under the leveling screws so that their adjustment will not penetrate the floor.

ELECTRICAL SPECIFICATIONS

A wiring diagram is located in this manual and inside the electrical box (41). The connection of this machine to the power source should only be made and inspected by a qualified electrician. This machine should be properly grounded. Improper wiring may result in accidental shock which could cause grave injury or death. Motor rotation should match the directional indicators found on the motor housing. The unit is equipped with 230v/460v, 3 phase, 60Hz motor. The manufacture's data on the motor will detail its specifications.



LM Control Box Overlay

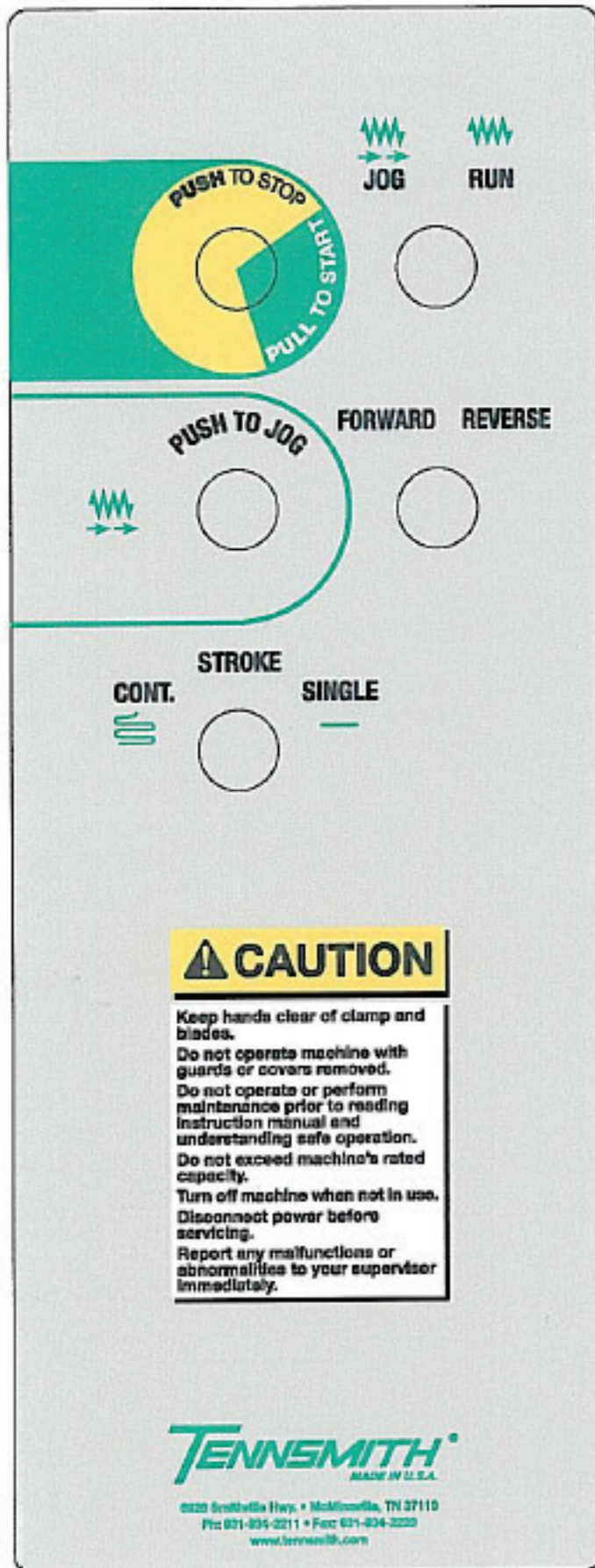

LM1010 SHEAR CONTROL PANEL OPERATION

Please refer to the previous page which shows the 4 functions of the control panel box on your LM1010 Shear

1. On/Off Push/Pull Switch:

This switch is located on the upper left corner of the box. It is labeled 1 on the previous page. To operate the shear, turn the main disconnect power switch to the on position and pull the **Push/Pull switch** to out position until the light illuminates the switch. The shear is now ready to operate.

Please note if your switch does not illuminate in the out position, you must immediately replace the bulb located within the switch. It is unsafe to operate this shear without the illuminated switch.

Please contact Tennsmith if you need assistance replacing the bulb.

2. To the right of the **Push/Pull Switch** is the **Jog/Run Switch**:

This selector type switch is designated 2 on the previous page. In normal shearing operation this switch should be in the **Run** position.

3. The **Jog Button** is located under the **Push/Pull switch** on the panel:

It is designated 3 on the previous page. The Jog function allows the operator to engage the motor and move the cutter head of the shear up or down slowly and hold the cutter head at a particular position. A secondary function of the Jog function is move the cutter head up if material is ever wedged between the blades and stalls your machine. The primary use of the Jog function is to check the clearance between the upper and lower blades at various points within the shearing cycle.

To operate the Jog function, select **Jog** on the switch 2 in the upper right corner of the panel. Next, select either Forward or Reverse on the switch designated 4 next to the Jog switch, and finally push the Jog switch to move the cutter head of the shear.

CAUTION! If you are performing a check of the clearance or blade gap of the shear, the shear must be in an off position at the Push/Pull switch 1 and at the main disconnect power switch located on the outside of the box. In addition a lockout tag must be securely placed on the main electrical connection anytime you are verifying the blade clearance.



If you have any questions on this procedure, please consult the factory prior to any adjustments on your shear.

4. Stroke Selector Switch:

This switch is located towards the bottom of the panel and is designated 5 on the previous page.

The switch has two options:

- a. Cont** – This is for continuous operation of the cutter head of the shear. To engage the continuous mode, select run on switch 2 (Jog/Run Switch) and select Cont. on the stroke selector switch. With this mode the cutter head will repeat continuously a full cycle until the operator releases his foot from the foot pedal of the shear. This mode is useful when cutting short strips of material that is generally 2” or less.
- b. Single** – With this mode, the shear will make one complete down and up cycle each time the foot pedal is pressed. This is the standard mode of operation on this shear.

Please contact the factory if you have any questions regarding the operation of this shear.

BLADE CLEARANCE

The blade clearance on the LM1010 was set at the factory to .004 in. on the ends of the blades with a .003 gap in the center of the machine. At this setting, your shear should provide satisfactory results over a broad range of materials and thickness. However, when shearing lighter gauge materials a tighter blade gap may be desired. Also, upon turning the blades to a new edge or after re-sharpening the blades, the blade clearance must be reset.

CAUTION! Checking the blade gap will require removing the wire finger guard (80). Do not operate the shear without the guard in place. To check the blade clearance, set the machine to the jog mode and jog the cutter head down so that the blades just overlap at the point at which the inspection is to take place.



WARNING! Disconnect power to the machine prior to making the measurement. Use a feeler gauge to make the measurement.

The blade clearance adjustment is made in the following manner:

1. Loosen the two table locking bolts (49) located near the mid-section of each side panel and then retighten the bolts hand tight.
2. Loosen the four table bolts (43), again reasserting only a slight amount of pressure back to each one.
3. The table positioning screws (20) located at both ends of the table are the means used to achieve the proper blade clearance. The forward screw pushes the table and bottom blade toward the cutter head. Likewise, the rear screw adjusts the blade back, thus increasing the clearance. To set the clearance, place a feeler gauge of the same thickness as the desired clearance between the two blades. Adjust the forward screw outward until the feeler gauge is locked between the blades and cannot be removed. Then adjust the rear screw in the opposite direction until the gauge stock is freed. The opposing actions of the screws serve to attain a tight, positive setting.
4. After setting the clearance on both ends of the machine, retighten the four table bolts and the two locking bolts.
5. The blade clearance in the center of the machine controlled by adjusting the center truss located at the rear of the cutter head. The blade clearance in the center of the shear should be set at least .001 closer than the dimension chosen for the ends of the blade.
6. Reposition all protective guards and covers.

Please contact the factory if you have any question regarding this procedure.

REPLACING/ROTATING BLADES

The blades on the LM Series shears are four edged blades constructed of high carbon, high chromium tool steel. Top and bottom blades are interchangeable. Upon utilizing all four edges of you blades, you may return the blades to the factory for re-sharpening or to a qualified blade re-sharpener, such as a blade manufacturer.

To remove and reposition the blades, the procedure is as follows:

1. **DANGER!** Disconnect the main electrical power source to the shear.



2. Removal of the hold down assembly (69)
 - A. **DANGER!** Never attempt to remove the hold down assembly without inserting and bottoming out the hold down compression bolts (1/2" x 6" bolts shipped with the machine) which are required to contain the spring pressure of the hold down pads while the assembly is removed from the shear. Remove the top sheet metal cover from the top of the hold down, and insert the compression bolts inside the hole mounts on top of the hold down until each bolt bottoms out.
 - B. After bottoming out the compression bolts, remove the four hex head bolts (81) which attach the hold down to the side panels on each end.
 - C. Use a sling and fork lift to remove the hold down after pulling the assembly free of the front gib screw space collars located on the side frames of the shear.
3. Removal of the top blade.

CAUTION! Use gloves to handle the blade to protect your hands. Place a wood block wedge between the upper and lower blades. Loosen the top blade bolts starting at the ends of the blade working toward the center. Rotate the blade to a new cutting edge and reversing the procedure, reinsert and snug the bolts working from the center out to each end.

4. With all bolts in place, securely torque the bolts while insuring that the blade is properly seated in the machined blade slot of the cutter head by using either a brass or wood pry bar.
5. Repeat the above procedures similarly to reposition the bottom blade.
6. Use the procedures outlined in the **BLADE CLEARANCE** section of this manual to reset the proper baled gap. **CAUTION!** Upon repositioning the shear blades, it is imperative that the bottom blade be adjusted well clear of the top blade before attempting to jog the cutter head down to make the blade clearance adjustment. Otherwise, crashing of the blades could result in severe damage to the machine.
7. Reposition the hold down assembly.

BACKGAUGE INFORMATION

The LM shear is fitted with a front operated back gauge as standard equipment. The gauge was installed and calibrated at the factory and shipped intact mounted on the shear. Inspect the gauge carefully to determine any possible movement or damage in transit.

The gauge has 30 inches of travel. To verify the back gauge was not disturbed during shipping, rotate the hand wheel bringing the gauge into contact with the bottom blade. The display should now read zero. If the display has a value other than zero and gauge is in fact in contact with the bottom blade, the unit must be adjusted.

ADJUSTING the BACKGAUGE

When adjusting the back gauge, first determine that the two upper support shafts (123) are inserted into the welded collars at the rear of the cutter head at equal amounts. The factory setting is 1.5 inches from the face of the collar to each of the front two support brackets (128). Upon verifying this dimension, notice that each support bracket has a hex head bolt threaded into the body of the bracket. When the gauge is brought in to a zero reading on the display, the head of these bolts contact the adjusting blocks (127) and provide for a more definite stop for the readout. To perform the adjustment, bring the adjusting blocks in contact with the bolts and then adjust the threaded rods (109) connected to the stop (100) so that the stop is flush against the bottom blade at both ends of the shear. Be certain to retighten the lock nuts (115) of the threaded rod.

Hold Down Adjustment

The following is the instructions to raise the hold down height to reduce the pressure (Hold down) on your LM shear:

1. Using the jog mode, depress the jog button until the machine cutter head reaches the bottom or its lowest position.
2. Disconnect the power to the machine.



3. Remove the sheet metal cover on the top of the hold down.
4. To raise the height of the hold down pad use two 7/8" wrenches unlock the two nuts that are locked and positioned against the square tube. Turn the bottom nut against the tube for 1 complete turn. Lock the top nut against the bottom.
5. Replace the top sheet metal cover to the hold down.
6. Reconnect the power to the machine.
7. Verify the clearance or height has been raised.

SHEET SUPPORT SYSTEM

a. **Single Stroke:**

When the foot pedal is activated, the sheet support will drop down and remain down until the cycle is complete and then return to the up position.

b. **Continuous Stroke:**

When the foot pedal is activated, the sheet support will drop down and stay down as long as the foot pedal is activated. When the foot pedal is released the cutter head will return to top of the stroke and the sheet support return to the up position.

c. **Speed of the System:**

The speed of the sheet support is regulated by the two flow controls on the sheet support air valve. The pressure to the system is regulated by the Filter / Regulator unit that the air supply connects to. Generally 80 psi on the regulator will give consistent operation providing the incoming air supply is 90 psi or higher (max 150 psi). The incoming air supply should also have a flow rate of at least 5 cfm with a 3 second recovery time.

d. **Dump Time:**

Rear dump sheet support systems generally have this time set to 0 seconds. The sheet support will drop as soon as the cutter head begins its down stroke.

Front dump sheet support systems have a slight delay (approximately .5 seconds) before the system drops.

Please consult the factory for adjustments for sheet support system speed.

MAINTENANCE

On a monthly basis, remove the top cover (11) of each side panel and grease the gib plates (9, 10, 15). This can be best accomplished by jogging the cutter head down to the extreme down-stroke position, thus exposing a majority of the gib surface.

WARNING! MAKE SURE THE POWER TO THE MACHINE HAS BEEN TURN OFF WHEN APPLYING LUBRICATES.



Also each month, apply grease to the zerk fitting of the support bearings (53) of the drive linkage shaft (55). Otherwise, periodic lubrication with a good grade of machine oil to the remaining moving parts such as those associated with the linkage are of the self-lubricating, oil impregnated composition. Additionally, the manufactures recommended maintenances schedule for the power unit of the shear is included in this manual as an appendix.

1. Lubrication should be performed every 30 days at points specified. Grease may extrude from bearing surface.
2. Lubrication grease specification Mobil XHP222 or equivalent.
3. SEW gear box - Oil levels and oil quality should be checked at frequent intervals, depending on usage. Oil changes are required at intervals of 10,000 operating hours or every two years, whichever comes first. If a synthetic oil lubricant is used, then this period can be extended to 20,000 operating hours or every four years, whichever comes first. In applications where hostile operating conditions exist, such as high humidity, corrosive environment, or large temperature changes, the lubricant should be changed at more frequent intervals.

Gearbox oil – Mobil Gear 630, temp +14 to +104deg F: MobilGear 629, -4 to +77 deg F or equivalent.

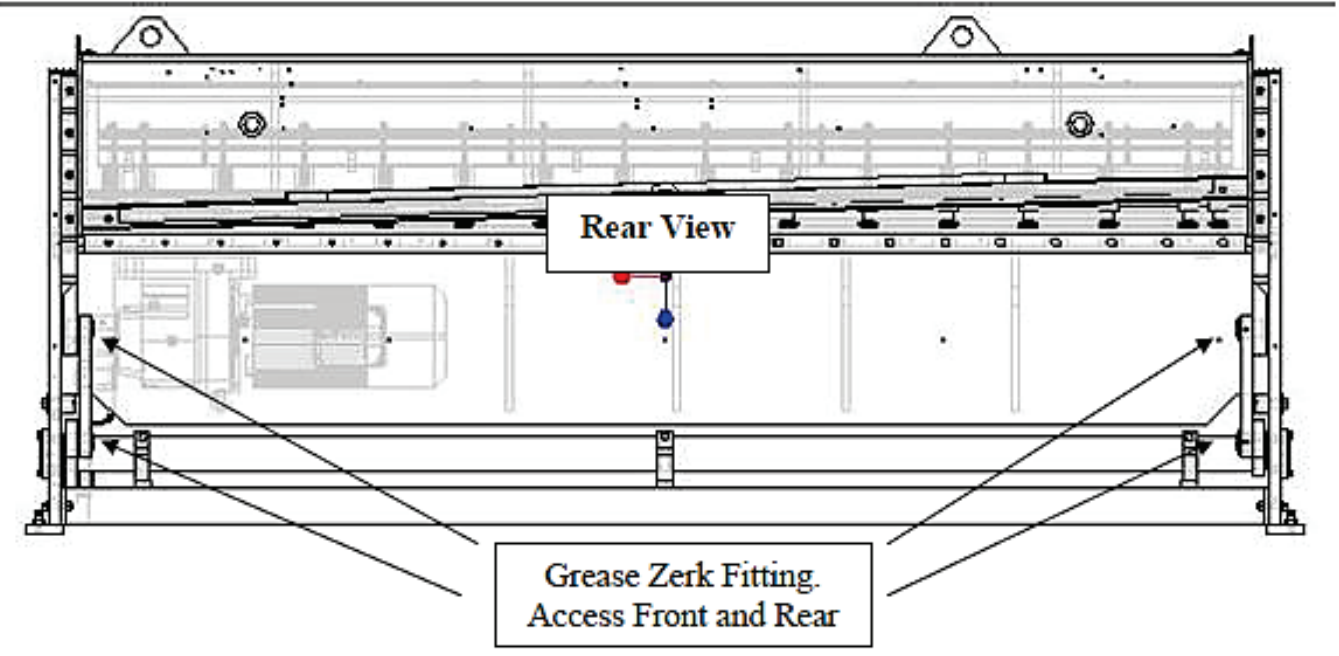
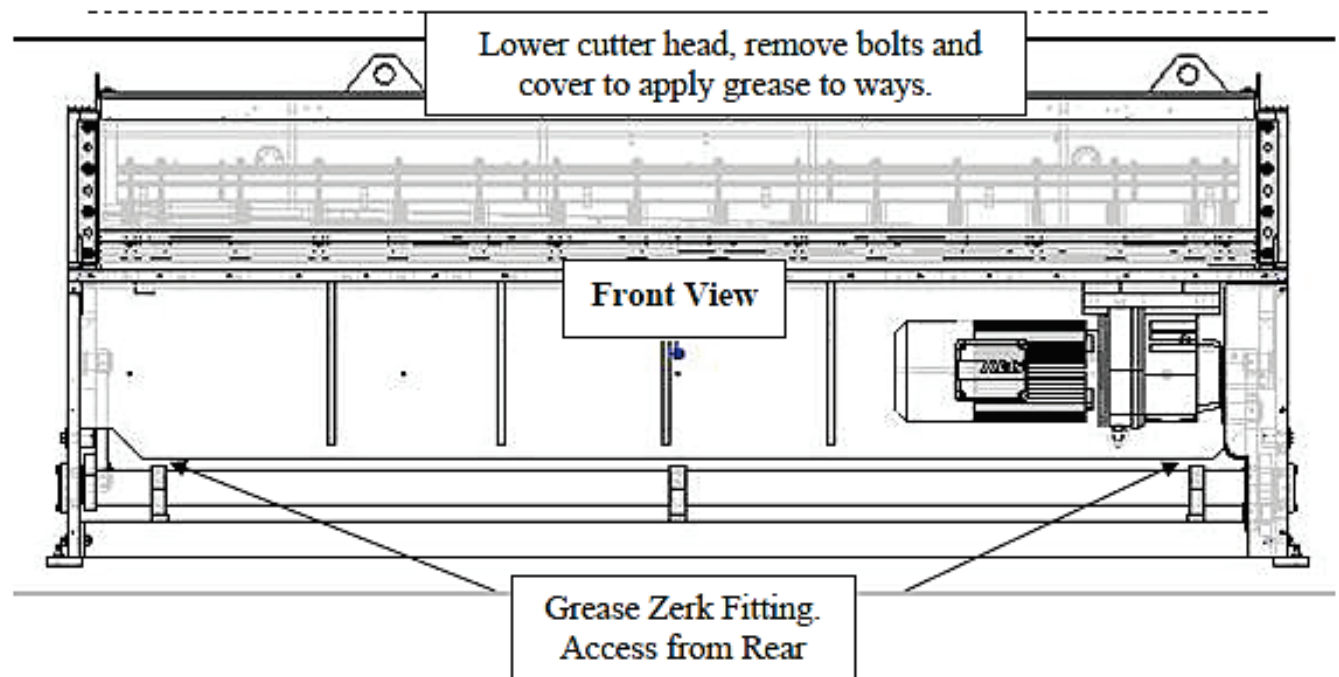

MODEL LM1010 PARTS LIST

ITEM#	LM PART#	DESCRIPTION	QTY.
1	1010001	CUTTER HEAD	1
2L	101002L	GIBB PLATE LEFT	1
2R	101002R	GIBB PLATE RIGHT	1
3	1010003	BLADE TOP & BOTTOM	2
4	1010004	SET SCREW, ROD MOUNTING	4
5	1010005	BOLT, BLADE MOUNTING	10
6	1010006	LOCK WASHER, BLADE	10
7	1010007	DOWEL PIN, GIBB PLATE	8
8	1010008	BOLT, GIBB PLATE	8
9	1010009	GIBB, CUTTER HEAD	2
10	1010010	BEARING MATERIAL, GIBB	4
11	1010011	TOP PLATE, SIDE PANEL	2
12	1010012	NUT, REAR GIBB ADJ.	6
13	1010013	SCREW, REAR GIBB ADJ.	6
14	1010014	BOLT, TOP PLATE SIDE PANEL	6
15	1010015	SPACER PLAET, SIDE PANEL	2
15A	101015A	BEARING MATERIAL SPACER	4
16	1010016	BOLT, SPACER PLATE	4
17	1010017	SPACER SLEEVE, HOLD DOWN	6
18	1010018	SCREW, GIBB ADJ. FRONT	6
19	1010019	NUT, SCREW, GIBB ADJ. FRONT	6
20	1010020	BOLT, TABLE ADJ.	4
21	1010021	SCREW, CONTROL BOX MOUNT	4
22	1010022	SIDE PANEL, RIGHT	1
23	1010023	BUSHING, COLLAR	2
24	1010024	COLLAR, TREADEL MOUNT	2
25	1010025	LOCK WASHER, BOLT COLLAR	4
26	1010026	BOLT, COLLAR MOUNTING	4
27	1010027	ARM, SWITCH TRIP	1
28	1010028	BOLT, ARM MOUNTING SWITCH	1
29	1010029	PIN, ARM MOUNTING SWITCH	2
30	1010030	LOCK WASHER, BOLT, ARM MOUNTING	1
31	1010031	NUT, ADJUSTER, SWITCH TRIP	1
32	1010032	ADJUSTER, SWITCH TRIP	1
33	1010033	LIMIT SWITCH	1
34	1010034	SCREW, SWITCH MOUNTING	2
35	1010035	BOLT, LEVEL ADJUSTING	4
36	1010036	NUT, BOLT, LEVEL ADJUSTING	4
37	1010037	BOLT, SUPPORT BEAM MOUNTING	4
38	1010038	SCREW, COVER MOUNTING SWITCH	4
39	1010039	COVER, SWITCH	1
40	1010040	SCREW, SPACER PLATE MOUNTING, SIDE	4

MODEL LM1010 PARTS LIST Continued

ITEM#	LM PART#	DESCRIPTION	QTY.
41	1010041	ELECTRIC CONTROL BOX	1
42	1010042	SWITCH, FORWARD REVERSE	1
43	1010043	BOLT, TABLE MOUNTING, TOP	4
44	1010044	BOLT, MATERIAL GUIDE BAR MOUNTING	4
45	1010045	MATERIAL GUIDE BAR	2
46	1010046	SCREW, SCALE MOUNTING, TABLE	2
47	1010047	SCALE, TOP	2
48	1010048	TABLE	1
49	1010049	BOLT, TABLE MOUNTING, ENDS	2
50	1010050	FLAT WASHER, BOLT, TABLE MOUNTING	2
51	1010051	SIDE PANEL, LEFT	1
52	1010052	BOLT, BEARING BLOCK MOUNTING	2
52A	101052A	BOLT, BEARING BLOCK MOUNTING	2
53	1010053	BEARING BLOCK, UPPER	2
54	1010054	BEARING BLOCK, LOWER	2
55	1010055	DRIVE SHAFT	1
55A	101055A	SPACER, SNAP RING, DRIVE SHAFT LINK	6
56	1010056	ELECTRIC GEAR MOTOR	1
57	1010057	BOLT, MOTOR AND GEAR BOX MOUNTING	4
58	1010058	KEY, SHAFT, GEAR BOX	1
59	1010059	BOLT, ARM AND PIN ASSEMBLY, GEAR BOX SHAFT	1
60	1010060	ARM AND PIN ASSEMBLY, GEAR BOX FRONT LINK	1
61	1010061	BEARING MATERIAL, BEARING BLOCK	2
62	1010062	SUPPORT BEAM	1
63	1010063	LINK, FRONT	1
64	1010064	LINK, REAR	2
65	1010065	REAR CHUTE	1
66	1010066	SCREW, REAR CHUTE MOUNTING	5
67	1010067	RETAINER RING, LINK MOUNTING	6
68	1010068	SPACER, LINK	12
69	1010069	HOLD DOWN	1
70	1010070	BOLT, HOLD DOWN MOUNTING	4
71	1010071	JACK SCREW, HOLD DOWN	6
72	1010072	NUT, STUD, FOOT MOUNTING, HOLD DOWN	10
73	1010073	STUD, FOOT MOUNTING, HOLD DOWN	10
74	1010074	BUSHING, QUILL, HOLD DOWN	10
75	1010075	FOOT, HOLD DOWN	10
76	1010076	RUBBER PAD, FOOT, HOLD DOWN	10
77	1010077	FINGER GUARD, HOOLD DOWN	1
78	1010078	SCREW, FINGER GUARD MOUNTING	6
79	1010079	FOOT SWITCH	1
79A	101079A	CABLE, FOOT SWITCH	1

LM 2x Back gauge Crank Assembly

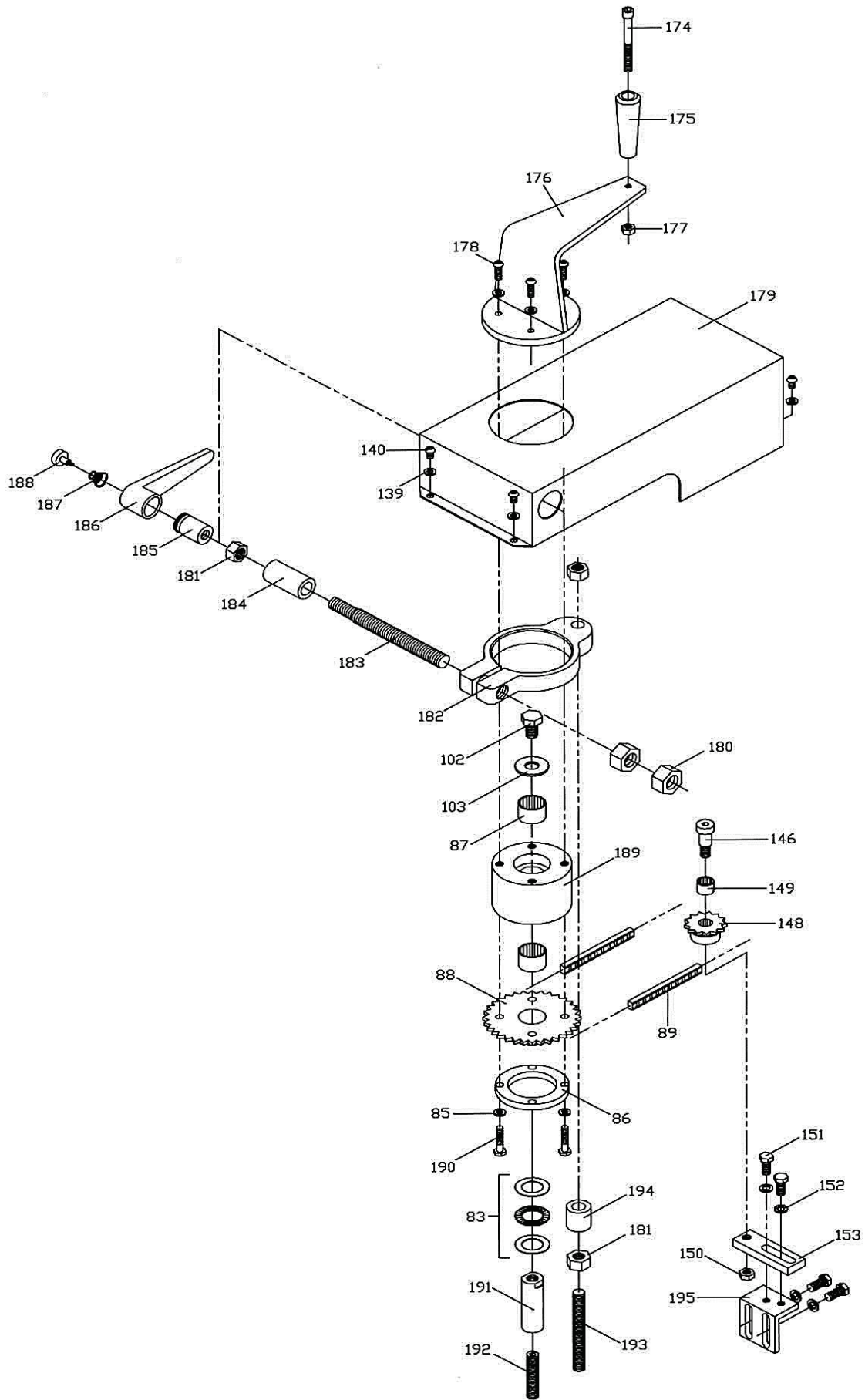

LM 2x Back gauge Crank Assembly Parts List

ITEM#	LM PART#	DESCRIPTION	QTY.
83	20083	THRUST WASHER	5
85	20085	LOCK WASHER, BOLT, SPROCKET MOUNTING	8
86	20086	SPACER RING, SPROCKET MOUNTING	4
87	20087	BEARING, SPROCKET MOUNTING	4
88	20088	SPROCKET	8
89	20089	CHAIN	1
102	20102	BOLT, SPROCKET AND SPACER BLOCK MOUNTING	3
103	20103	FLAT WASHER, BOLT, SPROCKET SPACER BLOCK	3
139	20139	SCREW, CRANK COVER MOUNTING	4
140	20140	LOCK WASHER, CRANK COVER MOUNTING	4
146	20146	STRIPPER BOLT, IDLER SPROCKET MOUNTING	3
147	20147	BEARING, IDLER SPROCKET	3
148	20148	IDLER SPROCKET	3
150	20150	NUT, STRIPPER BOLT, IDLER SPROCKET	3
151	20151	BOLT, IDLER SPROCKET BRACKET MOUNTING	12
152	20151	LOCK WASHER, BOLT, IDLER SPROCKET BRACKET	12
153	20153	BRACKET, IDLER SPROCKET MOUNTING	1
174	20174	BOLT, HANDLE MOUNTING	1
175	20175	HANDLE, CRANK	1
176	20176	CRANK	1
177	20177	NUT, BOLT, HANDLE MOUNTING	1
178	20178	SCREW, CRANK MOUNTING	4
179	20179	COVER, CRANK	1
180	20180	ACEME NUT, LOCK HANDLE	2
181	20181	NUT, LOCK HANDLE	1
182	20182	LOCK, CRANK BLOCK	1
183	20183	STUD, LOCK HANDLE	1
184	20184	SPACER, LOCK HANDLE	1
185	20185	NUT, LOCK HANDLE MOUNTING	1
186	20186	HANDLE, LOCK MOUNTING	1
187	20187	SPRING, LOCK HANDLE MOUNTING	1
188	20188	SCREW, HANDLE MOUNTING	1
189	20189	SPACER, SPROCKET MOUNTING	1
190	20190	SCREW, SPROCKET MOUNTING	4
191	20191	SPACER, SET SCREW	1
192	20192	SET SCREW	1
193	20193	STUD, LOCK MOUNTING	1
194	20194	SPACER, STUD	1
195	20195	BRACKET, IDLER SPROCKET BRACKET MOUNTING	1

LM 2x Back gauge Pointer Assembly

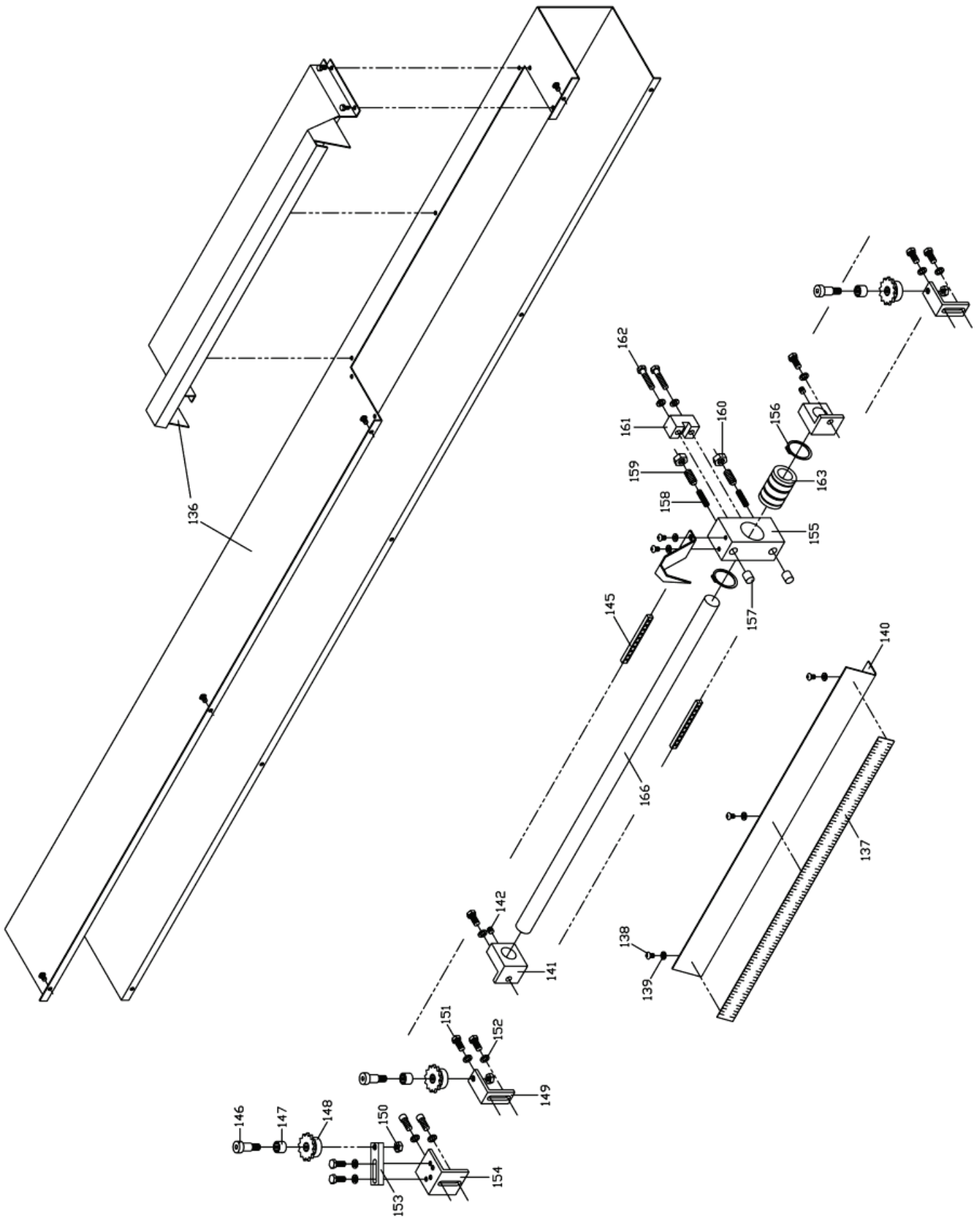

LM 2x Back gauge Pointer Assembly Parts List

ITEM#	LM PART#	DESCRIPTION	QTY.
136	20136	COVER, SCALE POINTER ASSEMBLY	1
137A	2137A	SCALE, INCH/METRIC 30 ICHES	1
138	20138	SCREW, SCALE BRACKET AND COVER MOUNTING	3
139	20139	LOCK WASHER, SCREW, SCALE BRACKET	3
140	20140	BRACKET, SCALE MOUNTING	1
141	20141	BRACKET, ROD MOUNTING	2
142	20142	SET SCREW, ROD MOUNTING	2
143	20143	BOLT, BRACKET MOUNTING	2
144	20144	LOCK WASHER, BOLT, BRACKET MOUNTING	2
145	20145	CHAIN	1
146	20146	STRIPPER BOLT, IDLER SPROCKET MOUNTING	3
147	20147	BEARING, IDLER SPROCKET	3
148	20148	IDLER SPROCKET	3
150	20150	NUT, STRIPPER BOLT, IDLER SPROCKET	3
151	20151	BOLT, IDLER SPROCKET BRACKET MOUNTING	12
152	20151	LOCK WASHER, BOLT, IDLER SPROCKET BRACKET	12
153	20153	BRACKET, IDLER SPROCKET MOUNTING	1
154	20154	BRACKET, IDLER SPROCKET BRACKET	1
155	20155	BLOCK, POINTER MOUNTING	1
156	20156	RETAINER, BEARING MOUNTING	2
157	20157	TEFLON PIN, POINTER BLOCK	2
158	20158	SPRING, POINTER BLOCK	2
159	20159	SET SCREW, POINTER BLOCK	2
160	20160	NUT, SET SCREW, POINTER BLOCK	2
161	20161	CLAMP, CHAIN LOCK, POINTER BLOCK	1
162	20162	BOLT, CLAMP MOUNTING, POINTER BLOCK	2
163	20163	BEARING, POINTER BLOCK	1
164	20164	SCREW, POINTER MOUNTING	2
165	20165	POINTER, SCALE	1

LM 2x Back gauge Drive Assembly Parts List

ITEM#	LM PART#	DESCRIPTION	QTY.
81	20081	BOLT, BRACE MOUNTING	2
82	20082	LOCK WASHER, BOLT, BRACE MOUNTING	2
83	20083	THRUST WASHER	5
84	20084	BOLT, SPROCKET MOUNTING	8
85	20085	LOCK WASHER, BOLT, SPROCKET MOUNTING	8
129	20129	LOCK WASHER, BOLT, SPROCKET MOUNTING	8
86	20086	SPACER RING, SPROCKET MOUNTING	4
87	20087	BEARING, SPROCKET MOUNTING	4
88	20088	SPROCKET	8
89	20089	CHAIN	1
90	20090	SPACER BLOCK, SPROCKET AND CRANK MOUNTING	1
91	20091	CHAIN	1
92	20092	SPACER RING, SPROCKET MOUNTING	3
93	20093	SHAFT, SPACER BLOCK AND SPROCKET MOUNTING	1
95	20095	SUPPORT BLOCK, FRONT	2
125	20125	SHAFT, SPROCKET ASSEMBLY MOUNTING LEFT	1

LM 2x Back gauge Drive Assembly

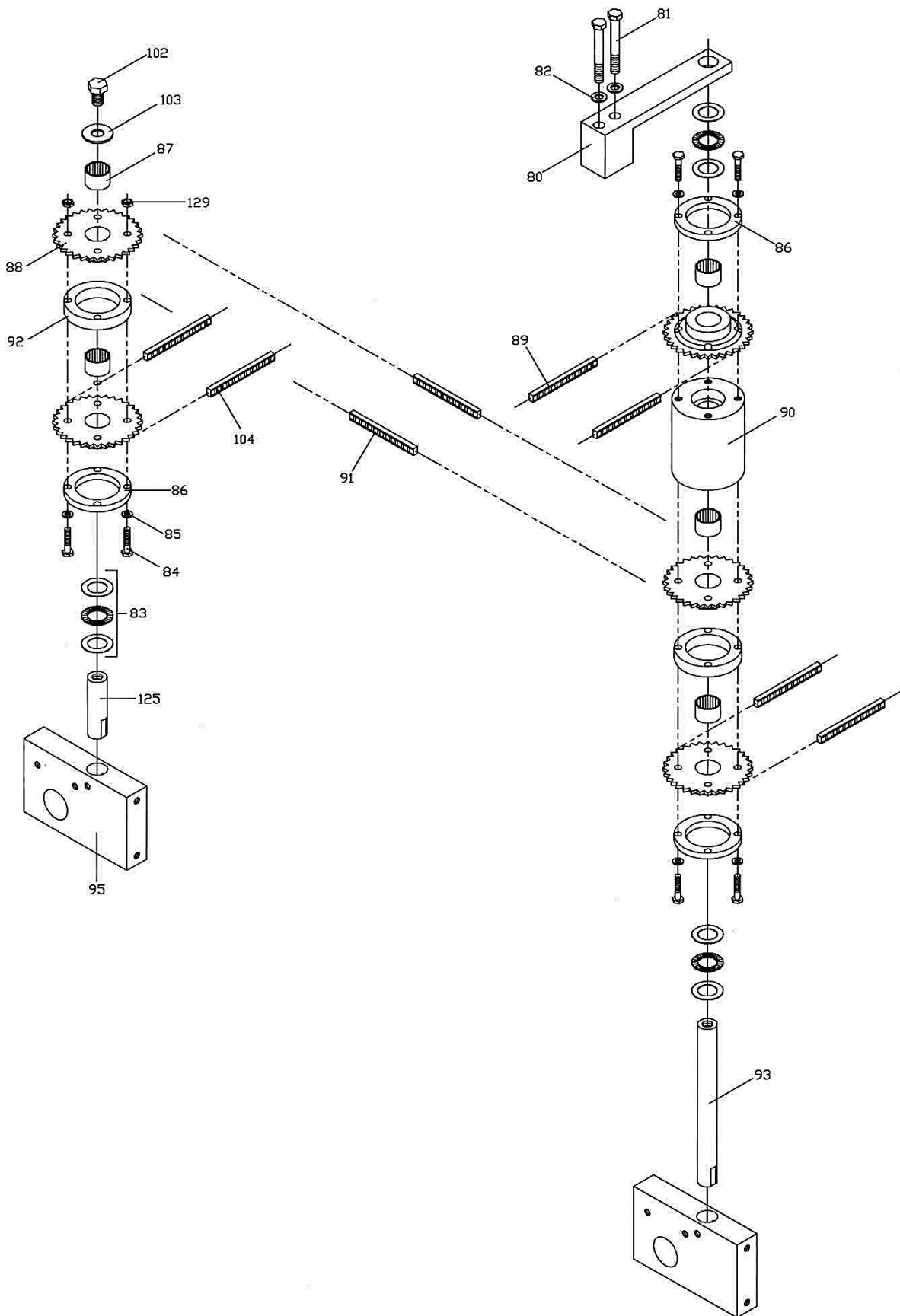

LM 2x Back gauge Arm Assembly

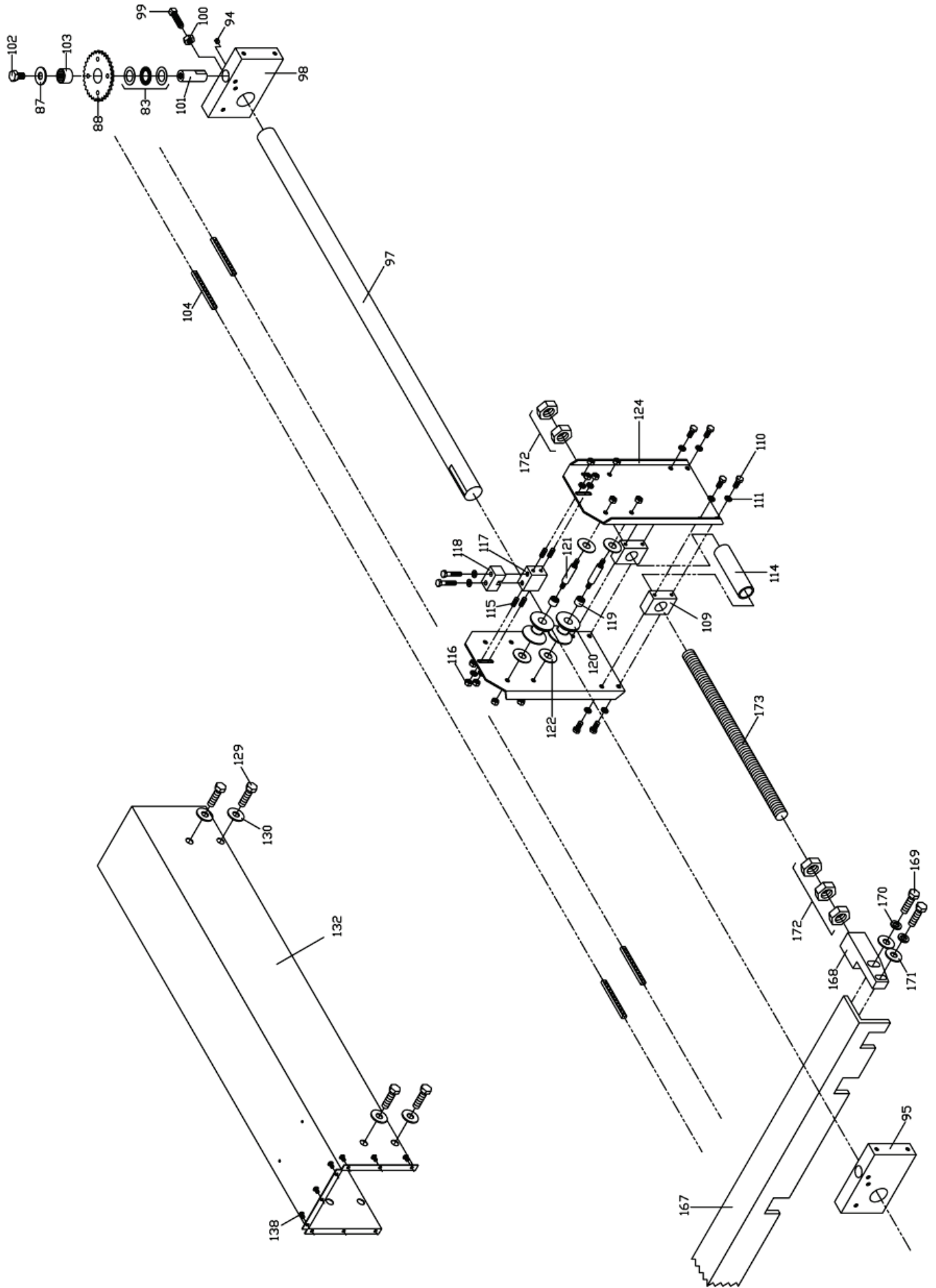

LM 2x Back gauge Arm Assembly Parts List

ITEM#	LM PART#	DESCRIPTION	QTY.
94	20094	SET SCREW, SHAFT MOUNTING	4
95	20095	SUPPORT BLOCK, FRONT	2
96	20096	SET SCREW, SUPPORT BLOCK MOUNTING	8
97	20097	SUPPORT ROD	2
98	20098	SUPPORT BLOCK, REAR	2
99	20099	BOLT, REAR SUPPORT BLOCK ADJUSTING	2
100	20100	JAM NUT, BOLT, REAR SUPPORT BLOCK ADJ	2
101	20101	SHAFT, SPROCKET MOUNTING, REAR	2
102	20102	BOLT, SPROCKET AND SPACER BLOCK MOUNTING	3
103	20103	FLAT WASHER, BOLT, SPROCKET SPACER BLOCK	3
104	20104	CHAIN, ROLLER ASSEMBLY	2
109	20109	SPACER BLOCK AND ROD HOLDER, ROLLER ASSY.	4
110	20110	BOLT, SWIVEL AND ROLLER ASSEMBLY	20
111	20111	LOCK WASHER, SWIVEL AND ROLLER ASSEMBLY	40
114	20114	SPACER, SWIVEL AND ROLLER ASSEMBLY	2
115	20115	SET SCREW, BRACKET MONTING ROLLER ASSY.	8
116	20116	JAM NUT, BRACKET MOUNTING, ROLLER ASSY.	8
117	20117	BRACKET, ROLLER ASSEMBLY	2
118	20118	CLAMP, CHAIN LOCK, ROLLER ASSEMBLY	2
119	20119	BOLT, CLAMP MOUNTING, CHAIN LOCK	4
120	20120	SPOOL, ROLLER ASSEMBLY	8
121	20121	SHAFT, SPOOL MOUNTING ROLLER ASSEMBLY	8
122	20122	BEARING, SPOOL, ROLLER ASSEMBLY	16
123	20123	TEFLON WASHER, ROLLER ASSEMBLY	16
124	20122	SIDE PLATE, ROLLER ASSEMBLY	2
129	20129	BOLT, COVER MOUNTING	8
130	20130	FLAT WASHER, BOLT, COVER MOUNTING	8
131	20131	COVER, LEFT	1
132	20132	COVER, RIGHT	1
138	20138	SCREW, COVER MOUNTING	18
167	20167	STOP, BACKGAUGE	1
168	20168	BRACKET, STOP MOUNTING LEFT	1
168A	2168A	BRACKET, STOP MOUNTING RIGHT	1
169	20169	BOLT, STOP BRACKET MOUNTING	4
170	20170	LOCK WASHER	4
171	20171	FLAT WASHER	4
172	20172	JAM NUT, STOP BRACKET MOUNTING ROD	10
173	20173	ROD, ALL THREAD	2

LM Four Foot Squaring Arm

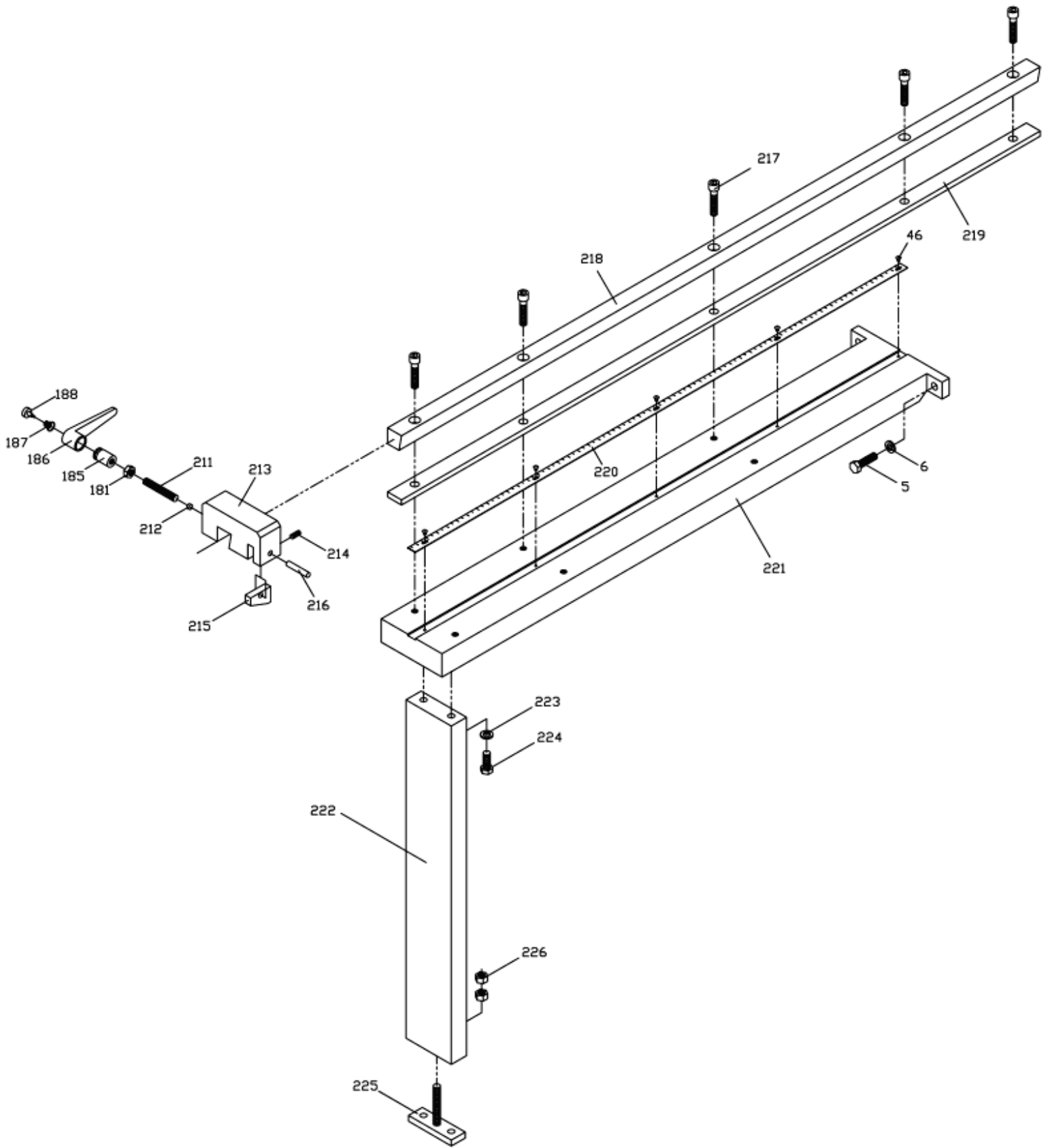

LM Four Foot Squaring Arm Parts List

ITEM#	LM PART#	DESCRIPTION	QTY.
5	40005	BOLT, TABLE, SQUARING ARM MOUNTING	2
6	40006	LOCK WASHER, BOLT, TABLE SQ ARM MOUNTING	2
46	40046	SET SCREW, SCALE	5
181	40181	NUT, LOCK HANDLE, BLOCK SQ ARM	1
185	40185	RATCHET STUD, LOCK HANDLE, BLOCK SQ ARM	1
186	40186	HANDLE, LOCK HANDLE, BLOCK SQ ARM	1
187	40187	SPRING, LOCK HANDLE, BLOCK SQ ARM	1
188	40188	SCREW, LOCK HANDLE, BLOCK SQ ARM	1
211	40211	THREADED STUD, LOCK HANDLE, BLOCK SQ ARM	1
212	40212	TEFLON STUD, LOCK HANDLE, BLOCK SQ ARM	1
213	40213	STOP BLOCK, SQUARING ARM	1
214	40214	SET SCREW, STOP BLOCK	1
215	40215	PIVOT BLOCK, STOP BLOCK	1
216	40216	STUD, PIVOT BLOCK, STOP BLOCK	1
217	40217	SCREW, GUIDE BAR, SQUARING ARM	5
218	40218	GUIDE BAR, FOUR FOOT, SQUARING ARM	1
219	40219	MATERIAL, GUIDE, FOUR FOOT, SQUARING ARM	1
220	40220	SCALE, FOUR FOOT, SQUARING ARM	1
221	40221	ARM, FOUR FOOT, SQUARING ARM	1
222	40222	LEG, FOUR FOOT, SQUARING ARM	1
223	40223	WASHER, BASE, LEG MOUNTING	2
224	40224	BOLT, BASE, LEG MOUNTING	2
225	40225	FLOOR MOUNT, SQUARING ARM	1
226	40226	NUT, FLOOR MOUNT, SQUARING ARM	2

LM Rear Sheet Support System

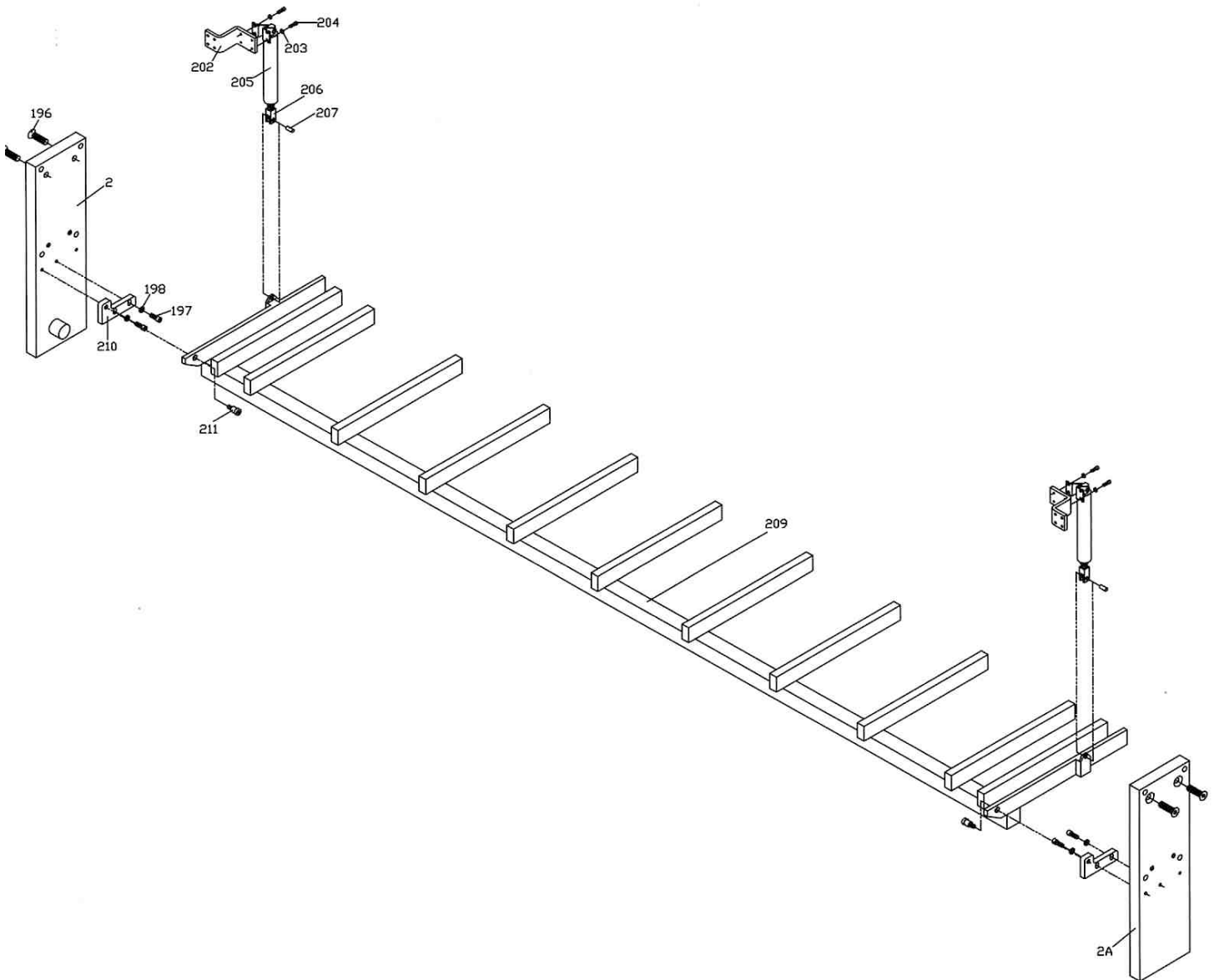

LM Rear Sheet Support System Parts List

ITEM#	LM PART#	DESCRIPTION	QTY.
197	RS5197	SCREW, BRACKET MOUNTING	4
198	RS5198	LOCK WASHER, BRACKET MOUNTING	4
199	RS5199	WASHER, RACK MOUNTING	2
200	RS5200	TEFLON WASHER, RACK MOUNTING	2
201	RS5201	STRIPPER BOLT, RACK MOUNTING	2
202	RS5202	BRACKET, AIR CYLINDER MOUNTING	2
203	RS5203	LOCK WASHER, AIR CYLINDER MOUNTING	4
204	RS5204	SCREW, AIR CYLINDER MOUNTING	4
205	RS5205	AIR CYLINDER, SHEET SUPPORT SYSTEM	2
206	RS5206	CLEVIS, AIR CYLINDER	2
207	RS5207	PIN, CLEVIS, AIR CYLINER	2
208	RS5208	RACK, SHEET SUPPORT SYSTEM, FRONT RETURN	1
209	RS5209	RACK, REAR, SHEET SUPPORT SYSTEM	1
210	RS5210	BRACKET, REAR SHEET SUPPORT, MOUNTING	2
211	RS5211	STRIPPER BOLT, REAR, RACK MOUNTING	2

LM1010 3 Phase - Rear Sheet Support

High Voltage Mains, AC Circuit

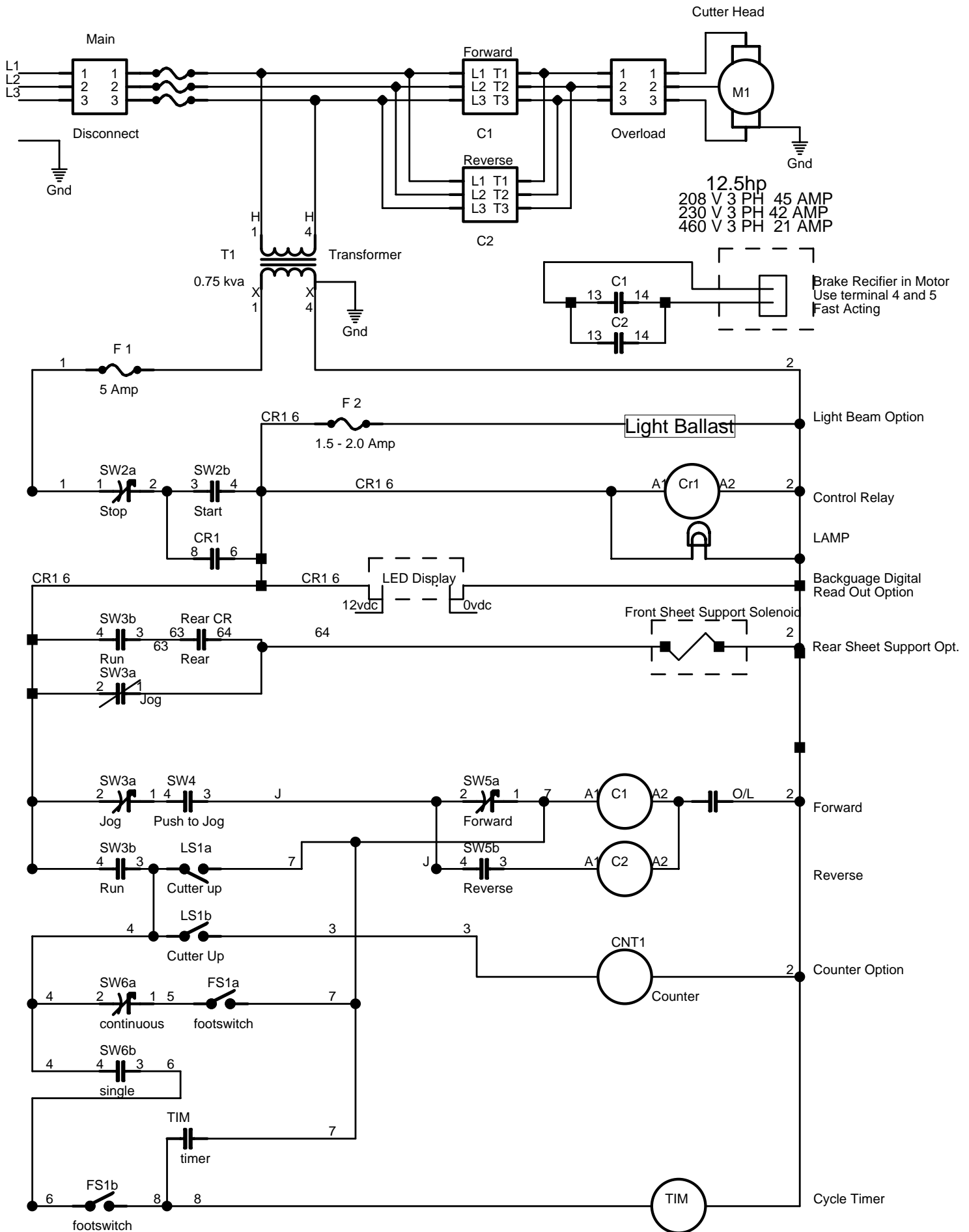

Gearmotors and Gear Reducers

GENERAL

These operating instructions are intended to help you install and operate the drive. For trouble free service, proper installation and operation are essential. Additionally, these instructions contain important recommendations on maintenance.

Before shipment, every SEW-Eurodrive gear unit is tested, checked and properly packed. However, please inspect the drive immediately upon arrival for shortage or transit damage. Note the damage or shortage on the freight bill of lading and file a claim with the carrier. Also, notify SEW-Eurodrive of the shortage or damage.

LUBRICANTS

All gearmotors and gear reducers are supplied with the correct grade and quantity of lubricating oil for the specified mounting position. Exceptions include reducers shipped without input assemblies. The recommended lubricants are found on page 2.

LONG TERM STORAGE

If the drive is not installed immediately, it should be stored in a dry, protected area. If the drive is to be stored for an extended period of time and was not ordered from SEW for long term storage, contact your nearest SEW assembly plant for information on Long Term Storage or request  **Document #2115**.

Drives which are used for standby service should be stored as a sealed gearcase.

INSTALLATION OF COMPONENTS ON DRIVE SHAFTS

Do not hammer on the shafts. Hammering can cause brinelling of the reducer's bearings shortening the bearing life. We recommend heating the components to approximately 175°F (when possible) and sliding them on the shaft. This will reduce possible damage to the reducer's bearings.  **Document #2116**.

For both standard and metric SEW shaft tolerances, refer to the SEW Catalog or request  **Document #2154**.

Shaft couplings should be properly aligned to prevent vibration, coupling wear, and premature failure of the shaft bearings.

To prevent the output shaft and bearings from being subjected to excessive loads, the maximum overhung load, as shown in SEW-Eurodrive catalogs, should not be exceeded. Please consult our engineering department if the load may exceed the recommended figure given or where there are combined radial and axial loads. In such cases, the exact operating conditions must be stated including speed, direction of rotation, position, magnitude and direction of the external radial and axial loads being applied.

SHAFT MOUNTED REDUCERS

SEW-Eurodrive supplies the recommended hollowshaft mounting paste with every hollowshaft reducer. The mounting paste is to be applied on the keyed output shaft. The mounting paste is to aid in the prevention of rusting and fretting corrosion between the reducer hollowshaft and the shaft of the driven machine. The mounting paste will aid in shaft removal when necessary.

Warning! Always ensure exposed, rotating parts are properly covered to ensure safety.

For additional information on shaft mounted reducers, drive shaft configuration and tolerances, refer to the SEW-Eurodrive Catalog or request  **Documents #2201 and #2202**.

INSTALLATION AND OPERATION

The drive installation site should be selected to ensure:

- Ambient temperatures below 40°C (104°F).
- Unimpeded flow of air to the motor and variable speed units.
- Accessibility to the drain, level and breather plugs.
- Adequate space for the removal of brakemotor fanguard for brake adjustment and maintenance.

The drive unit should be mounted on a flat, vibration damping, and torsionally rigid structure. Careful alignment is critical. Mounting to an uneven surface will cause housing distortion. The flatness tolerance of the supporting surface should not exceed:

- For gear units size 80 and smaller — 0.004 inch.
- For gear units above size 80 — 0.008 inch.

For transportation, the units are supplied with the breather plug already mounted. After the unit is installed, the black rubber seal located on the breather MUST BE REMOVED (Fig. 1). In addition, the oil level should be checked. Remove the plated (non-painted) oil level plug. The oil level is correct when the surface of the oil is level with the lowest point of that tapped hole, the exception is S37. Units W20 and W30 are sealed in any position.

Fig. 1

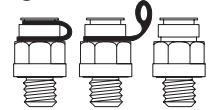

After installation, the actual mounting position should be confirmed against the mounting position shown on the gear reducer nameplate. Adequate lubrication is only guaranteed if the unit is mounted in the specific nameplated mounting position.

Refer to the SEW Catalog or request  **Document #2111, #2112, #2113, or #2114 (R, F, K, or S, respectively)** if a specific mounting position diagram is needed.

MAINTENANCE

Warning! Always ensure equipment is secure and electrical power is off before removing or performing maintenance on the drive assembly. Oil levels and oil quality should be checked at regular intervals, determined by usage and the environment. Grease and oil should be changed per the recommendations on page 2. Check coupling alignment, chain or belt tension, and mounting bolt torque periodically. Keep the drive relatively free of dust and dirt.



For additional information, call the SEW FAXline, 1-800-601-6195, and request document number shown.

**SEW
EURODRIVE**

**SOUTHEAST MANUFACTURING
& ASSEMBLY CENTER**
1295 Old Spartanburg Hwy, Lyman, SC 29365
(864) 439-7537 Fax: (864) 439-7830

SOUTHWEST ASSEMBLY CENTER
3950 Platinum Way, Dallas, TX 75237
(214) 330-4824 Fax: (214) 330-4724

MIDWEST ASSEMBLY CENTER
2001 West Main Street, Troy, OH 45373
(937) 335-0036 Fax: (937) 222-4104

EAST COAST ASSEMBLY CENTER
200 High Hill Road, Bridgeport, NJ 08014
(856) 467-2277 Fax: (856) 330-4724

WEST COAST ASSEMBLY CENTER
30599 San Antonio Road, Hayward, CA 94544
(510) 487-3560 Fax: (510) 487-6381



LUBRICANTS

LUBRICATION SCHEDULE FOR SEW-EURODRIVE GEAR UNITS									
Gear Reducer Type ¹⁾	Lubrication Type	Ambient air temperature range °F	ISO Viscosity Grade	Mobil Oil Co.	CHEVRON Oil Co.	Shell Oil Co.	Texaco Oil Co.	BP Oil Co.	Kluber Oil Co.
R F K	Oil	+14 to +104	VG220	Mobilgear 630	Chevron Non-Leaded Gear Compound 220	Shell Omala Oil 220	Meropa 220	BP Energol GP-XP 220	Kluberol GEM 1-220
		-4 to +77	VG150 VG100	Mobilgear 629	Chevron Non-Leaded Gear Compound 150	Shell Omala Oil 100	Meropa 150	BP Energol GP-XP 100	Kluberol GEM 1-150
S	Oil	+32 to +104	VG680	Mobilgear 636	Chevron Non-Leaded Gear Compound 680	Shell Omala Oil 680	Meropa 680	BP Energol GP-XP 680	Kluberol GEM 1-680
		+5 to +77	VG220	Mobilgear 630	Chevron Non-Leaded Gear Compound 220	Shell Omala Oil 220	Meropa 220	BP Energol GP-XP 220	Kluberol GEM 1-220
General	Synth. Oil	+176 to -40	Consult Factory For Use of Synthetic Oils						
	Synth. Grease	+176 to -40	Consult Factory For Use of Grease Filled Reducers						
Ball & Roller Bearings	Grease Used for normal application Temp. Range: -22°F to 140°F			Mobilux EP2	Chevron Dura-Lith EP2	Shell Alvania Grease R3	Multifak EP2	BP Energrease LS3	CENTOPLEX 2EP

¹⁾ Applies to all reducers with or without motor and input shaft.

Oil levels and oil quality should be checked at frequent intervals, depending on usage. Oil changes are required at intervals of 10,000 operating hours or every two years, whichever comes first. If a synthetic oil lubricant is used, then this period can be extended to 20,000 operating hours or every four years, whichever comes first. In applications where hostile operating conditions exist, such as high humidity, corrosive environment, or large temperature changes, the lubricant should be changed at more frequent intervals.

The gear units W20 and W30 are supplied with a synthetic oil which is good for the life of the reducer, independent of the mounting position.

Grease packed bearings should be cleaned and regreased every 10,000 hours or 20,000 hours for synthetic grease. Input (high speed) bearings should not be overgreased. They should be filled with grease not to exceed 1/3 of the bearing's free volume. For output bearings and bearings with replaceable grease shields, fill to 2/3 of their free volume.

ATTENTION

When the recommended lubricant is not available, it is permissible to use a lubricant having equivalent characteristics but we do not recommend that lubricants of different brands be mixed. Under no circumstances should synthetic lubricants be mixed with one another or with one having a mineral base.

LUBRICANTS

The approximate lubricant in US gallons and liters per mounting position is as follows:

Gear Unit	Mounting Position											
	M1 ¹⁾		M2 ¹⁾		M3 ²⁾		M4		M5 ²⁾		M6 ²⁾	
	Gallons	Liters	Gallons	Liters	Gallons	Liters	Gallons	Liters	Gallons	Liters	Gallons	Liters
RX57	0.16	0.6	0.21	0.8	0.34	1.3	0.34	1.3	0.24	0.9	0.24	0.9
RX67	0.21	0.8	0.21	0.8	0.45	1.7	0.50	1.9	0.29	1.1	0.29	1.1
RX77	0.29	1.1	0.40	1.5	0.69	2.6	0.71	2.7	0.42	1.6	0.42	1.6
RX87	0.45	1.7	0.66	2.5	1.27	4.8	1.27	4.8	0.77	2.9	0.77	2.9
RX97	0.55	2.1	0.90	3.4	1.96	7.4	1.85	7	1.27	4.8	1.27	4.8
RX107	1.03	3.9	1.48	5.6	3.06	11.6	3.14	11.9	2.03	7.7	2.03	7.7
RXF57	0.13	0.5	0.21	0.8	0.29	1.1	0.29	1.1	0.18	0.7	0.18	0.7
RXF67	0.18	0.7	0.21	0.8	0.40	1.5	0.45	1.7	0.26	1	0.26	1
RXF77	0.24	0.9	0.40	1.5	0.63	2.4	0.66	2.5	0.42	1.6	0.42	1.6
RXF87	0.42	1.6	0.66	2.5	1.29	4.9	1.24	4.7	0.77	2.9	0.77	2.9
RXF97	0.55	2.1	0.95	3.6	1.88	7.1	1.85	7	1.27	4.8	1.27	4.8
RXF107	0.82	3.1	1.56	5.9	2.96	11.2	2.77	10.5	1.90	7.2	1.90	7.2
R17/R17F	0.07	0.25	0.16	0.6	0.09	0.35	0.16	0.6	0.09	0.35	0.09	0.35
R27/R27F	0.07 (0.11)	0.25 (0.4)	0.18	0.7	0.11	0.4	0.18	0.7	0.11	0.4	0.11	0.4
R37/R37F	0.08 (0.26)	0.3 (1)	0.24	0.9	0.26	1	0.29	1.1	0.21	0.8	0.26	1
R47/R47F	0.18 (0.40)	0.7 (1.5)	0.42	1.6	0.40	1.5	0.45	1.7	0.40	1.5	0.40	1.5
R57/R57F	0.21 (0.45)	0.8 (1.7)	0.50	1.9	0.45	1.7	0.55	2.1	0.45	1.7	0.45	1.7
R67/R67F	0.29 (0.61)	1.1 (2.3)	0.69 (0.92)	2.6 (3.5)	0.74	2.8	0.85	3.2	0.48	1.8	0.53	2
R77/R77F	0.32 (0.79)	1.2 (3)	1.00 (1.14)	3.8 (4.3)	0.95	3.6	1.14	4.3	0.66	2.5	0.90	3.4
R87/R87F	0.61 (1.59)	2.3 (6)	1.77 (2.22)	6.7 (8.4)	1.90	7.2	2.03	7.7	1.66	6.3	1.72	6.5
R97	1.22 (2.59)	4.6 (9.8)	3.09 (3.70)	11.7 (14)	3.09	11.7	3.54	13.4	2.99	11.3	3.09	11.7
R107	1.59 (3.62)	6 (13.7)	4.31	16.3	4.46	16.9	5.07	19.2	3.49	13.2	4.20	15.9
R137	2.64 (6.61)	10 (25)	7.40	28	7.79	29.5	8.32	31.5	6.61	25	6.61	25
R147	4.07 (10.57)	15.4 (40)	12.29	46.5	12.68	48	13.74	52	10.44	39.5	10.83	41
R167	7.13 (18.49)	27 (70)	21.66	82	20.61	78	23.25	88	17.44	66	18.23	69
RF17	0.07	0.25	0.16	0.6	0.09	0.35	0.16	0.6	0.09	0.35	0.09	0.35
RF27	0.07 (0.11)	0.25 (0.4)	0.18	0.7	0.11	0.4	0.18	0.7	0.11	0.4	0.11	0.4
RF37	0.11 (0.26)	0.4 (1)	0.24	0.9	0.26	1	0.29	1.1	0.21	0.8	0.26	1
RF47	0.18 (0.40)	0.7 (1.5)	0.42	1.6	0.40	1.5	0.45	1.7	0.40	1.5	0.40	1.5
RF/RM57	0.21 (0.45)	0.8 (1.7)	0.48	1.8	0.45	1.7	0.53	2	0.45	1.7	0.45	1.7
RF/RM67	0.32 (0.66)	1.2 (2.5)	0.71 (0.95)	2.7 (3.6)	0.71	2.7	0.82	3.1	0.50	1.9	0.55	2.1
RF/RM77	0.32 (0.69)	1.2 (2.6)	1.00 (1.08)	3.8 (4.1)	0.87	3.3	1.08	4.1	0.63	2.4	0.79	3
RF/RM87	0.63 (1.59)	2.4 (6)	1.8 (2.09)	6.8 (7.9)	1.88	7.1	2.03	7.7	1.66	6.3	1.69	6.4
RF/RM97	1.35 (2.69)	5.1 (10.2)	3.14 (3.70)	11.9 (14)	2.96	11.2	3.70	14	2.96	11.2	3.12	11.8
RF/RM107	1.66 (3.94)	6.3 (14.9)	4.20	15.9	4.49	17	5.07	19.2	3.46	13.1	4.20	15.9
RF/RM137	2.51 (6.61)	9.5 (25)	7.13	27	7.66	29	8.59	32.5	6.61	25	6.61	25
RF/RM147	4.33 (11.10)	16.4 (42)	12.42	47	12.68	48	13.74	52	11.10	42	11.10	42
RF/RM167	6.87 (18.49)	26 (70)	21.66	82	20.61	78	23.25	88	17.17	65	18.76	71

¹⁾ On compound gear units the primary (larger) gear unit is provided with the oil quantity in parenthesis.

²⁾ On compound gear units having mounting positions M3, M5, or M6 the secondary (smaller) gear unit is provided with the oil filling of the M1 flanged mounting position.



For additional information on R-Series mounting positions, refer to the SEW Catalog or call the SEW FAXline, 1-800-601-6195, and request Document #2111.

LUBRICANTS

The approximate lubricant in US gallons and liters per mounting position is as follows:

Gear Unit	Mounting Position											
	M1		M2		M3		M4		M5		M6	
	Gallons	Liters	Gallons	Liters	Gallons	Liters	Gallons	Liters	Gallons	Liters	Gallons	Liters
F27	0.16	0.6	0.21	0.8	0.18	0.7	0.18	0.7	0.16	0.6	0.16	0.6
F37	0.26	1	0.32	1.2	0.18	0.7	0.32	1.2	0.26	1	0.29	1.1
F47	0.40	1.5	0.48	1.8	0.29	1.1	0.50	1.9	0.40	1.5	0.45	1.7
F57	0.69	2.6	0.98	3.7	0.55	2.1	0.92	3.5	0.74	2.8	0.77	2.9
F67	0.71	2.7	1.00	3.8	0.50	1.9	1.00	3.8	0.77	2.9	0.85	3.2
F77	1.32	5	1.93	7.3	1.14	4.3	2.11	8	1.59	6	1.66	6.3
F87	2.64	10	3.43	13	2.03	7.7	3.65	13.8	2.85	10.8	2.91	11
F97	4.89	18.5	5.94	22.5	3.33	12.6	6.66	25.2	4.89	18.5	5.28	20
F107	6.47	24.5	8.45	32	5.15	19.5	9.91	37.5	7.13	27	7.13	27
F127	10.70	40.5	14.53	55	8.98	34	16.12	61	12.29	46.5	12.42	47
F157	18.23	69	27.48	104	16.64	63	27.74	105	22.72	86	20.61	78
FF27	0.16	0.6	0.21	0.8	0.18	0.7	0.18	0.7	0.16	0.6	0.16	0.6
FF37	0.26	1	0.32	1.2	0.18	0.7	0.34	1.3	0.26	1	0.29	1.1
FF47	0.42	1.6	0.50	1.9	0.29	1.1	0.50	1.9	0.40	1.5	0.45	1.7
FF57	0.74	2.8	1.00	3.8	0.55	2.1	0.98	3.7	0.77	2.9	0.79	3
FF67	0.71	2.7	1.00	3.8	0.50	1.9	1.00	3.8	0.77	2.9	0.85	3.2
FF77	1.35	5.1	1.93	7.3	1.14	4.3	2.14	8.1	1.59	6	1.66	6.3
FF87	2.72	10.3	3.49	13.2	2.06	7.8	3.73	14.1	2.91	11	2.96	11.2
FF97	5.02	19	5.94	22.5	3.33	12.6	6.74	25.5	4.99	18.9	5.42	20.5
FF107	6.74	25.5	8.45	32	5.15	19.5	10.17	38.5	7.27	27.5	7.40	28
FF127	10.96	41.5	14.80	56	8.98	34	16.64	63	12.29	46.5	12.95	49
FF157	19.02	72	27.74	105	16.91	64	28.01	106	22.99	87	20.87	79
FA/FH/FV27 FAF/FHF/FVF27 FAZ/FHZ/FVZ27	0.16	0.6	0.21	0.8	0.18	0.7	0.18	0.7	0.16	0.6	0.16	0.6
FA/FH/FV37 FAF/FHF/FVF37 FAZ/FHZ/FVZ37	0.26	1	0.32	1.2	0.18	0.7	0.32	1.2	0.26	1	0.29	1.1
FA/FH/FV47 FAF/FHF/FVF47 FAZ/FHZ/FVZ47	0.40	1.5	0.48	1.8	0.29	1.1	0.50	1.9	0.40	1.5	0.45	1.7
FA/FH/FV57 FAF/FHF/FVF57 FAZ/FHZ/FVZ57	0.71	2.7	1.00	3.8	0.55	2.1	0.95	3.6	0.77	2.9	0.79	3
FA/FH/FV67 FAF/FHF/FVF67 FAZ/FHZ/FVZ67	0.71	2.7	1.00	3.8	0.50	1.9	1.00	3.8	0.77	2.9	0.85	3.2
FA/FH/FV77 FAF/FHF/FVF77 FAZ/FHZ/FVZ77	1.32	5	1.93	7.3	1.14	4.3	2.11	8	1.59	6	1.66	6.3
FA/FH/FV87 FAF/FHF/FVF87 FAZ/FHZ/FVZ87	2.64	10	3.43	13	2.03	7.7	3.65	13.8	2.85	10.8	2.91	11
FA/FH/FV97 FAF/FHF/FVF97 FAZ/FHZ/FVZ97	4.89	18.5	5.94	22.5	3.33	12.6	6.61	25	4.89	18.5	5.28	20
FA/FH/FV107 FAF/FHF/FVF107 FAZ/FHZ/FVZ107	6.47	24.5	8.45	32	5.15	19.5	9.91	37.5	7.13	27	7.13	27
FA/FH/FV127 FAF/FHF/FVF127 FAZ/FHZ/FVZ127	10.30	39	14.53	55	8.98	34	16.12	61	11.89	45	12.29	46.5
FA/FH/FV157 FAF/FHF/FVF157 FAZ/FHZ/FVZ157	17.97	68	27.21	103	16.38	62	27.48	104	22.46	85	20.34	77



For additional information on F-Series mounting positions, refer to the SEW Catalog or call the SEW FAXline, 1-800-601-6195, and request Document #2112.

LUBRICANTS

The approximate lubricant in US gallons and liters per mounting position is as follows:

Gear Unit	Mounting Position											
	M1		M2		M3		M4		M5		M6	
	Gallons	Liters	Gallons	Liters	Gallons	Liters	Gallons	Liters	Gallons	Liters	Gallons	Liters
K37	0.13	0.5	0.26	1	0.26	1	0.34	1.3	0.26	1	0.26	1
K47	0.21	0.8	0.34	1.3	0.40	1.5	0.53	2	0.42	1.6	0.42	1.6
K57	0.32	1.2	0.61	2.3	0.66	2.5	0.79	3	0.69	2.6	0.63	2.4
K67	0.29	1.1	0.63	2.4	0.69	2.6	0.90	3.4	0.69	2.6	0.69	2.6
K77	0.58	2.2	1.08	4.1	1.16	4.4	1.56	5.9	1.11	4.2	1.16	4.4
K87	0.98	3.7	2.11	8	2.30	8.7	2.88	10.9	2.06	7.8	2.11	8
K97	1.85	7	3.70	14	4.15	15.7	5.28	20	4.15	15.7	4.10	15.5
K107	2.64	10	5.55	21	6.74	25.5	8.85	33.5	6.34	24	6.34	24
K127	5.55	21	10.96	41.5	11.62	44	14.27	54	10.57	40	10.83	41
K157	8.19	31	16.38	62	17.17	65	23.78	90	15.32	58	16.38	62
K/KH167	9.25	35	26.42	100	26.42	100	33.03	125	22.46	85	22.46	85
K/KH187	15.85	60	44.91	170	44.91	170	54.16	205	34.35	130	34.35	130
KF37	0.13	0.5	0.29	1.1	0.29	1.1	0.40	1.5	0.26	1	0.26	1
KF47	0.21	0.8	0.34	1.3	0.45	1.7	0.58	2.2	0.42	1.6	0.42	1.6
KF57	0.34	1.3	0.61	2.3	0.71	2.7	0.79	3	0.77	2.9	0.71	2.7
KF67	0.29	1.1	0.63	2.4	0.74	2.8	0.95	3.6	0.71	2.7	0.71	2.7
KF77	0.55	2.1	1.08	4.1	1.16	4.4	1.59	6	1.19	4.5	1.19	4.5
KF87	0.98	3.7	2.17	8.2	2.38	9	3.14	11.9	2.22	8.4	2.22	8.4
KF97	1.85	7	3.88	14.7	4.57	17.3	5.68	21.5	4.15	15.7	4.36	16.5
KF107	2.64	10	5.81	22	6.87	26	9.25	35	6.61	25	6.61	25
KF127	5.55	21	10.96	41.5	12.15	46	14.53	55	10.83	41	10.83	41
KF157	8.19	31	17.44	66	18.23	69	24.31	92	16.38	62	16.38	62
KA/KH/KV37 KAF/KHF/KVF37 KAZ/KHZ/KVZ37	0.13	0.5	0.26	1	0.26	1	0.37	1.4	0.26	1	0.26	1
KA/KH/KV47 KAF/KHF/KVF47 KAZ/KHZ/KVZ47	0.21	0.8	0.34	1.3	0.42	1.6	0.55	2.1	0.42	1.6	0.42	1.6
KA/KH/KV57 KAF/KHF/KVF57 KAZ/KHZ/KVZ57	0.34	1.3	0.61	2.3	0.71	2.7	0.79	3	0.77	2.9	0.71	2.7
KA/KH/KV67 KAF/KHF/KVF67 KAZ/KHZ/KVZ67	0.29	1.1	0.63	2.4	0.71	2.7	0.95	3.6	0.69	2.6	0.69	2.6
KA/KH/KV77 KAF/KHF/KVF77 KAZ/KHZ/KVZ77	0.55	2.1	1.08	4.1	1.22	4.6	1.59	6	1.16	4.4	1.16	4.4
KA/KH/KV87 KAF/KHF/KVF87 KAZ/KHZ/KVZ87	0.98	3.7	2.17	8.2	2.32	8.8	2.93	11.1	2.11	8	2.11	8
KA/KH/KV97 KAF/KHF/KVF97 KAZ/KHZ/KVZ97	1.85	7	3.88	14.7	4.15	15.7	5.28	20	4.15	15.7	4.15	15.7
KA/KH/KV107 KAF/KHF/KVF107 KAZ/KHZ/KVZ107	2.64	10	5.42	20.5	6.34	24	8.45	32	6.34	24	6.34	24
KA/KH/KV127 KAF/KHF/KVF127 KAZ/KHZ/KVZ127	5.55	21	10.96	41.5	11.36	43	13.74	52	10.57	40	10.57	40
KA/KH/KV157 KAF/KHF/KVF157 KAZ/KHZ/KVZ157	8.19	31	17.44	66	17.70	67	22.99	87	16.38	62	16.38	62



For additional information on K-Series mounting positions, refer to the SEW Catalog or call the SEW FAXline, 1-800-601-6195, and request Document #2113.

LUBRICANTS

The approximate lubricant in US gallons and liters per mounting position is as follows:

Gear Unit	Mounting Position											
	M1		M2		M3 ¹⁾		M4		M5		M6	
	Gallons	Liters	Gallons	Liters	Gallons	Liters	Gallons	Liters	Gallons	Liters	Gallons	Liters
S37	0.07	0.25	0.11	0.4	0.13	0.5	0.16	0.6	0.11	0.4	0.11	0.4
S47	0.09	0.35	0.21	0.8	0.18 (0.24)	0.7 (0.9)	0.29	1.1	0.21	0.8	0.21	0.8
S57	0.13	0.5	0.32	1.2	0.26 (0.32)	1 (1.2)	0.40	1.5	0.34	1.3	0.34	1.3
S67	0.26	1	0.53	2	0.58 (0.82)	2.2 (3.1)	0.85	3.2	0.69	2.6	0.69	2.6
S77	0.50	1.9	1.11	4.2	0.98 (1.43)	3.7 (5.4)	1.59	6	1.16	4.4	1.16	4.4
S87	0.87	3.3	2.14	8.1	1.82 (2.75)	6.9 (10.4)	3.17	12	2.22	8.4	2.22	8.4
S97	1.80	6.8	3.96	15	3.54 (4.76)	13.4 (18)	5.94	22.5	4.49	17	4.49	17
SF37	0.07	0.25	0.11	0.4	0.13	0.5	0.16	0.6	0.11	0.4	0.11	0.4
SF47	0.11	0.4	0.24	0.9	0.24 (0.29)	0.9 (1.1)	0.32	1.2	0.26	1	0.26	1
SF57	0.13	0.5	0.32	1.2	0.26 (0.40)	1 (1.5)	0.42	1.6	0.37	1.4	0.37	1.4
SF67	0.26	1	0.58	2.2	0.61 (0.79)	2.3 (3)	0.85	3.2	0.71	2.7	0.71	2.7
SF77	0.50	1.9	1.08	4.1	1.03 (1.53)	3.9 (5.8)	1.72	6.5	1.29	4.9	1.29	4.9
SF87	1.00	3.8	2.11	8	1.88 (2.67)	7.1 (10.1)	3.17	12	2.40	9.1	2.40	9.1
SF97	1.96	7.4	3.96	15	3.65 (4.97)	13.8 (18.8)	6.24	23.6	4.76	18	4.76	18
SA/SH37 SAF/SHF37 SAZ/SHZ37	0.07	0.25	0.11	0.4	0.13	0.5	0.16	0.6	0.11	0.4	0.11	0.4
SA/SH47 SAF/SHF47 SAZ/SHZ47	0.11	0.4	0.21	0.8	0.18 (0.24)	0.7 (0.9)	0.29 ²⁾	1.1 ²⁾	0.21	0.8	0.21	0.8
SA/SH57 SAF/SHF57 SAZ/SHZ57	0.13	0.5	0.29	1.1	0.26 (0.40)	1 (1.5)	0.42	1.6	0.32	1.2	0.32	1.2
SA/SH67 SAF/SHF67 SAZ/SHZ67	0.26	1	0.53	2	0.48 (0.69)	1.8 (2.6)	0.77	2.9	0.66	2.5	0.66	2.5
SA/SH77 SAF/SHF77 SAZ/SHZ77	0.48	1.8	1.03	3.9	0.95 (1.32)	3.6 (5)	1.56	5.9	1.19	4.5	1.19	4.5
SA/SH87 SAF/SHF87 SAZ/SHZ87	1.00	3.8	1.96	7.4	1.59 (2.30)	6 (8.7)	2.96	11.2	2.11	8	2.11	8
SA/SH97 SAF/SHF97 SAZ/SHZ97	1.85	7	3.70	14	3.01 (4.23)	11.4 (16)	5.55	21	4.15	15.7	4.15	15.7

¹⁾ On compound gear units the primary (larger) gear unit is provided with the oil quantity in parenthesis.

²⁾ When combined with a 2-pole motor at M4 mounting position, the oil quantity must be reduced to 0.28 gallons (1.05 liters).



For additional information on S-Series mounting positions, refer to the SEW Catalog or call the SEW FAXline, 1-800-601-6195, and request Document #2114.

For compound drives the R reducer requires its own oil filling as shown in the chart:

Gear Unit	Mounting Position					
	M1/M3/M5/M6		M2		M4	
	Gallons	Liters	Gallons	Liters	Gallons	Liters
R17	0.07	0.25	0.16	0.6	0.16	0.6
R37	0.11	0.4	0.24	0.9	0.29	1.1
R57	0.21	0.8	0.48	1.8	0.53	2
R77	0.32	1.2	1.00	3.8	1.08	4.1
R87	0.63	2.4	1.8	6.8	2.03	7.7
R97	1.35	5.1	3.14	11.9	3.70	14
R107	1.66	6.3	4.20	15.9	5.07	19.2

Motors and Brakemotors

Type BM (G) Brakes

OPERATING INSTRUCTIONS

09 793 67 US

General

Every SEW-Eurodrive motor is thoroughly tested, checked, and properly packed prior to shipment. However, please check immediately upon arrival for shortage of parts or transit damage. Note the damage or shortage on the freight bill of lading and file a claim with the carrier. Also, notify SEW-Eurodrive of the shortage or damage.

Installation

For motors mounted integrally to a gear unit, please refer to the Operating Instructions for Gearmotors and Gear Reducers for proper installation of the drive. The drive installation site should be selected to ensure:

- Ambient temperatures below 40°C (104°F).
- Unimpeded flow of air to the motor and variable speed units.
- Accessibility to gear unit, oil plugs.
- Adequate space for the removal of the brakemotor fangard for brake adjustment and maintenance.

The drive unit should be mounted on a flat, vibration damping, and torsionally rigid structure. The flatness tolerance of the supporting surface should not exceed:

For motor size 180 and smaller — 0.004 inch
For motor size above 180 — 0.008 inch

Do not hammer on the shafts to install couplings, sheaves, etc. Hammering can cause brinelling of the bearings and a reduction in bearing life. We recommend heating the components to approximately 175°F and sliding them on. This will reduce possible damage to the bearings. In addition, there is a metric tapped hole in the center of the motor shaft that can be utilized with a tool to press on or remove the coupling, sheaves, etc.

The motor shaft diameters are metric and have tolerances as listed in the SEW-Eurodrive catalogs. Shaft couplings should be properly aligned to prevent vibration, coupling wear and premature failure of the shaft bearings.

Maximum Parallel Offset — 0.003 inch
Maximum Angular Offset — 0.030°

To prevent the output shaft and bearings from being subjected to excessive loads, the maximum overhung loads, as shown in SEW-Eurodrive catalogs, should not be exceeded. Please consult our engineering department if the load may exceed the recommended figure given or where there are combined radial and axial loads. In such cases, the exact operating conditions must be stated including speed, direction of rotation, position, magnitude and direction of the external radial and axial loads being applied.

Long Term Storage

If the motor must be stored for a long period of time without operating, the motor must be stored in a dry, protected area, and in the mounting position indicated on the unit nameplate. In order to ensure that the motor has not been damaged by moisture after a prolonged storage, the insulation resistance should be checked. An insulation tester with a measurement voltage of at least 500V (e.g. magneto generator) should be used for this purpose. The insulation resistance is sufficient if it has an ohmic

value of at least $1000 \times V_N$ (e.g. at $V_N = 230\text{VAC}$: $R_{\text{insul}} \geq 230000$ ohms = 0.23M ohms). If the measured value is smaller, the motor should be dried before use (for example, with hot air up to a maximum of 90°C or by resistance heating with an auxiliary AC voltage of 10% of V_N via an isolating transformer). Care should be taken to ensure that the motor is heated with not more than 20% of its rated current and that the rise in temperature is not more than 90°C. The drying procedure can be stopped when the insulation resistance has reached $500000 = 0.5\text{M}$ ohms.

Severe Duty Units

Severe Duty Units are indicated with the letters “-KS” at the end of the motor type on the motor nameplate. Severe Duty units include drain holes in the motor end bells and conduit box at the lowest points allowing condensation to drain out of the motor.

CAUTION!

The drain holes are installed for the mounting position listed on the gearbox nameplate. Installing a unit in a mounting position other than what is shown on the nameplate will reposition the condensation drain holes. As a result, the drain holes may not be located at the lowest point and may not allow water to drain. This can cause premature drive failure.

Electrical Connection

The motor must be installed and connected by a qualified electrician who is knowledgeable with the NEC article 430 and local regulations. He must make sure that the voltage and frequency of the electrical supply correspond with the data stamped on the motor nameplate before connecting the motor in accordance with the wiring diagram, which can be found in the terminal box. For brake connections, see the following pages.

At installation the electrician must make sure that the terminal block jumpers are positioned correctly and that all electrical connections including the ground connection are secure. In order to effectively protect the motor from overloads, appropriate motor protection must be provided. Fuses do not always provide adequate motor protection. For motors which are required to operate with a very high start-stop frequency, the overload heater type motor protection is insufficient. It is advisable in such applications to provide the motor with temperature sensors (thermistors) in the windings. Monitor the thermistors by means of an external trip device. In this way, the motor will be fully protected against practically all possible overloads.

When using motors outdoors or in washdown applications the cable entries into the terminal box must be directed downward to prevent water from entering the conduit box. The unused cable entries must be closed off properly.

Lubrication and Maintenance

WARNING! Always ensure equipment is secure and electrical power is off before removing or performing maintenance on the drive assembly. The motor bearings are sealed and the grease content is adequate for the life of the bearing.

SEW
EURODRIVE

**SOUTHEAST MANUFACTURING
& ASSEMBLY CENTER**
1295 Spartanburg Highway/Lyman SC 29365
(864) 439-7537 Fax: (864) 439-7830

SOUTHWEST ASSEMBLY CENTER
3950 Platinum Way/Dallas TX 75237
(214) 330-4824 Fax: (214) 330-4724

MIDWEST ASSEMBLY CENTER
2001 West Main Street/Troy OH 45373
(937) 335-0036 Fax: (937) 222-4104

EAST COAST ASSEMBLY CENTER
200 High Hill Road/Bridgeport NJ 08014
(856) 467-2277 Fax: (856) 845-3179

WEST COAST ASSEMBLY CENTER
30599 San Antonio Road/Hayward CA 94544
(510) 487-3560 Fax: (510) 487-6381



Brake Coil Resistance

Motor Frame		DT71-80	DT80	DT90-100	DT100	DV112-132S	DV132M-160M	DV160L-225
Brake Size		BM(G)05	BM(G)1	BM(G)2	BM(G)4	BM(G)8	BM15	BM30/31/32/62
Brake Torque (lb-ft)		0.89 - 3.7	4.4 - 7.4	3.7 - 14.8	17.7 - 29.5	7.00 - 55.3	18.4 - 110.6	36.9 - 442.5
BRAKE VOLTAGE		$R_B(\Omega)$	$R_B(\Omega)$	$R_B(\Omega)$	$R_B(\Omega)$	$R_B(\Omega)$	$R_B(\Omega)$	$R_B(\Omega)$
AC (to rectifier V_B)	DC	$R_T(\Omega)$	$R_T(\Omega)$	$R_T(\Omega)$	$R_T(\Omega)$	$R_T(\Omega)$	$R_T(\Omega)$	$R_T(\Omega)$
—	24	4.3 13.2	3.8 11.8	3.3 10.3	7 8.2	1.6 8.2	0.8 5.0	0.7 5.3
105-116	48	17.1 52.5	15.2 47.0	13.3 40.9	10.7 32.7	6.2 32.7	3.1 20.1	2.8 21.1
186-207	80	54.0 166	48.1 149	42.1 129	33.8 103	19.6 103	9.8 63.5	8.9 66.7
208-233	96	68.0 209	60.5 187	53.0 163	42.5 130	24.7 130	12.4 80.8	11.2 84.0
330-369	147	171 525	152 470	133 409	107 327	62 327	31.1 201	28.1 211
370-414	167	215 661	191 591	168 515	134 411	78.1 411	39.2 253	35.4 266
415-464	185	271 832	241 744	211 649	169 518	98.3 518	49.3 318	44.6 334
465-522	208	341 1047	303 937	266 817	213 652	110 577	62.1 401	56.1 421

Voltage AC - The voltage shown is the nameplate AC brake voltage supplied to the brake rectifier.

DC - The voltage shown is the effective DC voltage required by the brake coil. The measured voltage from the rectifier will be 10-20% lower than that shown.

Brake Coil Resistance - values must be measured with the brake coil disconnected from the rectifier.

R_B - Accelerator coil resistance in Ω , measured from the red to the white brake coil wire.

R_T - Fractional coil resistance in Ω , measured from the white to the blue brake coil wire.

Brake Connection (AC Voltage)

SEW-Eurodrive motor brakes can be connected in a number of different ways. In order to connect the brake for each application, it is important to refer to the data on the motor nameplate that describes the brake system. The brake fields are: brake voltage, brake torque and brake control.

This operating instruction covers AC brake voltages with the following brake control components. If the brake voltage is DC, or if the brake control components differ from those listed below, an additional operating instruction must be consulted for connection information.

SEW-Eurodrive fail-safe mechanical brakes are DC controlled. Standardly, a brake rectifier (halfwave) is provided to convert the AC line voltage to the DC voltage required to drive the brake. 24VDC brakes do not include a rectifier. When voltage (V_B) is applied to the brake, it will release. When voltage (V_B) is removed from the brake, it will set. The brake rectifier can be wired either for normal brake reaction time (setting, stopping) or fast brake reaction time. The fast brake reaction will set the brake more quickly which will provide a shorter and more repeatable stopping distance. There are two basic types of brake rectifiers, BG and

Brake Control (Rectifier)	Part Number
BG1.5	825 384 6
BG3.0	825 386 2
BGE1.5	825 385 4
BGE3.0	825 387 0

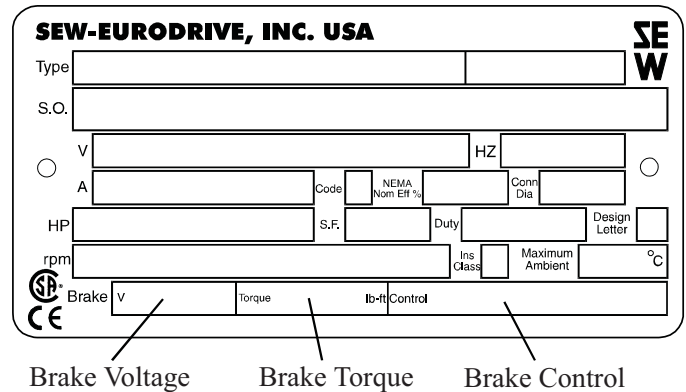

BGE. The BG brake rectifier is standard on motor sizes DT71 - DT100. The BGE rectifier is standard on motor sizes DV112 - DV225. The BGE rectifier can be ordered with motor sizes DT71 - DT100 and will provide faster brake release times allowing the motor to cycle more frequently.

The wiring diagrams for brake connections are located on the inside of the motor conduit box lid. The brake will release and allow the motor to rotate when the nameplate AC brake voltage V_B is supplied to the brake rectifier terminals. There are certain cases where the brake rectifier can receive its voltage from the motor's terminal block, meaning that when power is applied to the motor it will simultaneously release the brake and start the motor. See page 3 for this description.

Brake Voltage Supplied from the Motor

There are specific instances when the brake voltage can be tapped from the motor's terminal block. The advantage of brake systems wired in this way is when power is applied to the motor, the brake releases, (requiring no additional brake supply power wiring). The brake can be wired to the motor terminal block under the following conditions: a single speed motor; the motor is started and run across the line (i.e., no inverter or electronic soft start). The connections shown on this page are for normal brake reaction time. For rapid brake reaction time, incorporate the contact as shown on the brake diagram located on the inside of the motor conduit box lid.

Brake Motor Connection

Single Speed Dual Voltage - Connection Diagram DT72

Example Motor Voltages:

230 /460 Volts - 60 Hz

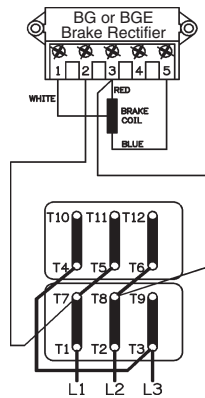

Motor wired for low voltage.
Brake voltage matches low motor voltage.
Example: 230/460V Motor
Motor wired 230V
Brake voltage 230V

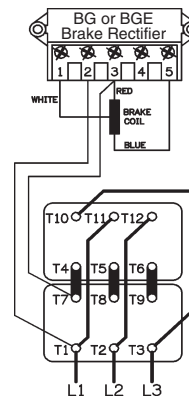

Motor wired for high voltage.
Brake voltage matches low motor voltage.
Example: 230/460V Motor
Motor wired 460V
Brake voltage 230V

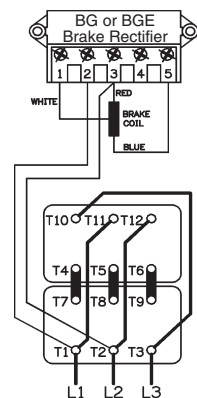

Motor wired for high voltage.
Brake voltage matches high motor voltage.
Example: 230/460V Motor
Motor wired 460V
Brake voltage 460V

Brake Motor Connection

Single Speed Dual Voltage - YY/Y Connection Diagram DT79

Example Motor Voltages:

230YY/460Y Volts - 60 Hz

200YY/400Y Volts - 50 Hz

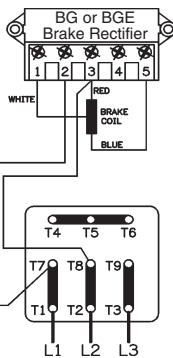

Motor wired for low voltage.
Brake voltage matches low motor voltage.
Example: 230/460V Motor
Motor wired 230V
Brake voltage 230V

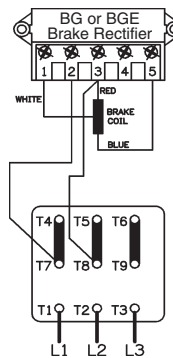

Motor wired for high voltage.
Brake voltage matches low motor voltage.
Example: 230/460V Motor
Motor wired 460V
Brake voltage 230V

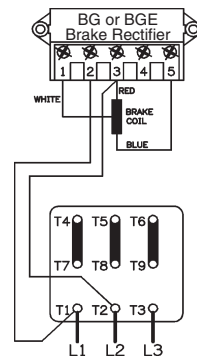

Motor wired for high voltage.
Brake voltage matches high motor voltage.
Example: 230/460V Motor
Motor wired 460V
Brake voltage 460V

Brake Motor Connection

Single Speed Dual Voltage - /Y Connection Diagram DT13

Examples Motor Voltages:

200 /346Y Volts - 60 Hz

330 /575Y Volts - 60 Hz

220 /380Y Volts - 50 Hz

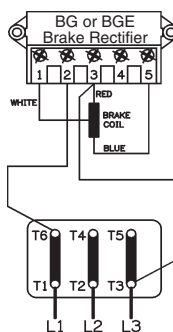

Motor wired for low voltage.
Brake voltage matches low motor voltage.
Example: 200/346V Motor
Motor wired 200V
Brake voltage 200V

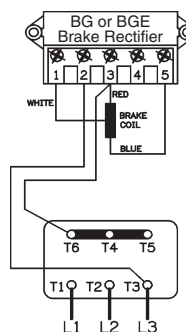

Motor wired for high voltage.
Brake voltage matches low motor voltage.
Example: 220/380V Motor
Motor wired 380V
Brake voltage 220V

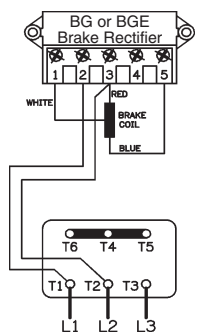

Motor wired for high voltage.
Brake voltage matches high motor voltage.
Example: 220/380V Motor
Motor wired 380V
Brake voltage 380V

Re-adjusting the Brake Air Gap

A properly adjusted brake air gap is critical for correct operation. The following table indicates the required air gap measurement.

Motor Size	Brake Size	Air Gap
DT71 - DT100	BM(G)05 - BM(G)4	0.010"-0.024" (0.25-0.6 mm)
DV112 - DV225	BM(G)8 - BM31	0.012"-0.047" (0.3-1.2 mm)
DV180-DV225	BM32-BM62 Double Disc	0.016"-0.047" (0.4-1.2 mm)

Prolonged use of the brake will wear the brake disc lining. This wear increases the air gap. When the air gap approaches its maximum value, the brake must be re-adjusted. To re-adjust the brake, follow the procedure below.

1. Remove the fan cover (14), fan snapping, fan (17), rubber seal (2), and any accessories at the fan end.
2. Insert a feeler gauge between the brake coil body (21) and the stationary disc (22), tighten the adjusting nuts (19) until the minimum value for the air gap is reached equally around the brake. With motor size 160L and up (brakes BM30 to BM62) first screw the threaded bushings (24) into the endshield. After setting the air gap, lock the bushings (24) against the coil body.
3. Ensure a play of 0.06" to 0.08" (1.5 to 2 mm) in the releasing arm. See "THE HAND RELEASE MECHANISM."

Replacement of the Brake Disc (26)

Extended operation of the brake may wear the brake disc (26) beyond acceptable limits. The thickness of the brake disc can be measured to determine if this has occurred.

Motor Size	Brake Size	Min. Disc (26) Thickness
DT71 - DT100	BM05 - BM4	0.354" (9mm)
DV112 - DV225	BM8 - BM62	0.394" (10mm)

If the brake disc (26) is worn below the measurement given, it must be replaced. If the thickness is greater than the specification above, the brake disc is still usable and the brake can be re-adjusted.

The Hand Release Mechanism

Most of our brakes are supplied with a hand-operated release lever. This allows opening of the brake without applying power, allowing for adjustments on the driven machinery.

There are two brake release mechanisms available:

The "BMHR" (4) type requires a lever to be inserted into the release arm. To open the brake, pull the lever away from the motor. It will re-engage automatically, once the lever is released. The lever, when not used, is attached to the motor's cooling fins with clamps.

The screw-type "BMHF" (5) arrangement requires a hexagon key which, when turned clockwise, opens the brake.

Since the stationary disc (22) will move away from the coil body during the brake's operation, it is vital that there is free play (floating clearance) on the release arm of 0.060"-0.080" (1.5-2.0 mm). The springs (11) should be placed between the arm (7) and the nuts (12) to eliminate noise.

The brake release mechanism is not used to change the brake's torque setting. There must always be clearance on the lever.

Troubleshooting

Fault: Motor does not run

1. Check the motor and brake wiring for damage and proper connection.

2. At the motor, measure the line voltage, line current and motor resistance of all three phases.
3. If all three phases read a similar current value the following conditions may exist:

- The motor may be blocked by either an excessive external load, or problems in the reducer or the brake. In both cases, the motor should draw locked rotor (in-rush) current. Consult SEW-Eurodrive catalogs for these values. Release the brake mechanically, reset the air gap if needed, or disconnect the load from the output shaft.

- If the brake is at fault electrically see #4 below.

- If the current differs significantly from the rated locked rotor current, the motor is either an incorrect voltage, or it is jumpered for the wrong voltage.

4. If the brake can be released mechanically, but does not respond to voltage, check the brake for electrical problems.

- Make sure the wiring is according to the instructions. Pay special attention to the brake voltage.

- Energize the brake circuit and measure the AC voltage on the rectifier terminals 2 and 3 (BG/BGE rectifiers). The measured voltage should correspond to the nameplate inscription: "Brake V."

- Measure the DC voltage across terminals 3 and 5 of the brake rectifier which should be about 35% to 45% of the previously measured AC voltage.

- If there is no fault found to this point, measure the resistance of the brake coils. Disconnect the coil from the rectifier for this measurement. See the table on Page 2 for the brake coil resistance values.

- Measure the resistance of each brake coil lead to the brake coil body. This test should show an open circuit. If a short is found, the brake coil is damaged.

If the results of all these checks (electrical connection, mechanical checks and adjustments, and electrical tests) indicate that the brake should work, then the most likely cause of the brake's failure to release is a damaged brake rectifier.

Fault: Brake stopping time is too slow

If the brake has been operating well for some time and a gradual increase in stopping time has occurred, the release arm may have come in contact with the coil body. Verify that the brake release arm end play is correct, and check for excessive brake disc wear, (see previous instructions).

If the brake has been in operation for some time, and the stopping has become erratic, dust accumulation around the stationary disc guides may be the cause. Remove the brake's rubber sealing collar and clean with an air hose.

If the application is new, check the brake's wiring and air gap. If the brake is not wired for fast response, then changing the brake wiring to fast response will decrease the stopping time. Vertical motion and indexing applications may also require the fast response connection. Increasing the brake's torque may remedy the situation, but will also increase stress on the transmission.

On applications requiring excessive brake work, the lining's surface may become glazed due to extreme heat. The application of a BGE rectifier will improve this situation dramatically. BGE rectifiers are standard equipment on motors size DV 112 - DV225, but optional on the smaller sizes DT71-DT100. Contact SEW-Eurodrive for more information.

BM(G) Brake Cross Section and Exploded Views

BM(G) 05 - BM 15

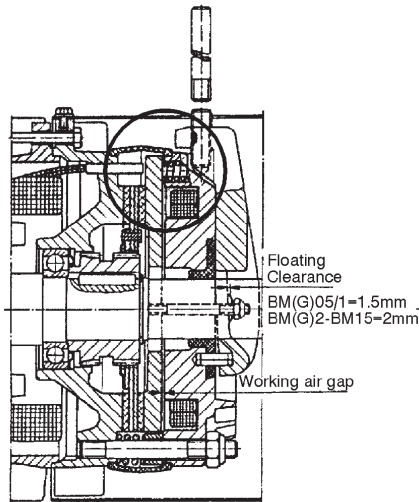

BM 30/31

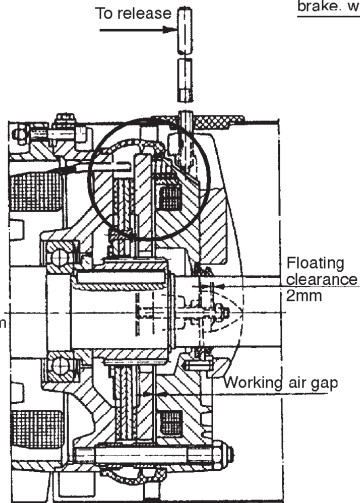

BM 32/62

Hand lever for manually disengaging the brake. will re-engage itself when released

Manual brake release screw for fixing brake in the dis-engaged position

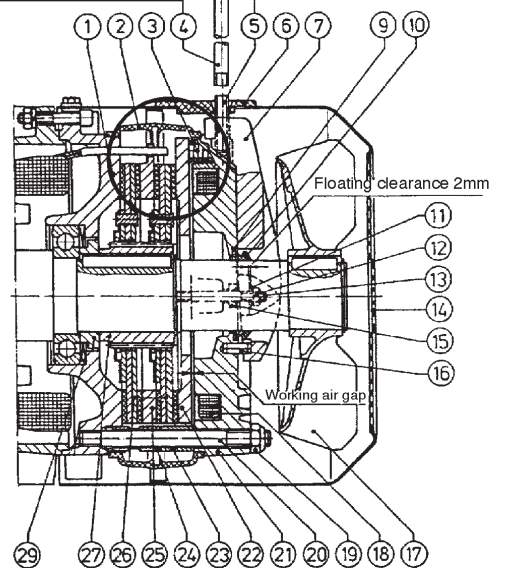

- (1) Brake end shield
- (2) Rubber sealing collar
- (3) Braking springs
- (4) Hand release lever
- (5) Releasing screw
- (6) Closing plate
- (7) Release arm
- (9) Sealing ring
- (10) V-ring
- (11) Conical spring
- (12) Release
- (13) Stud
- (14) Fanguard
- (15) Grommet

- (16) Dowel pin
- (17) Fan
- (18) N/A
- (19) Brake adjustment nut
- (20) Retaining stud
- (21) Brake coil body
- (22) Stationary disc
- (23) Pressure ring
- (24) Setting sleeve
- (25) Dual brake pad stationary disc
- (26) Brake disc complete
- (27) Carrier
- (29) Cup Spring

Exploded view of the BM and BMG single-disk brake (motor sizes 71-160M)

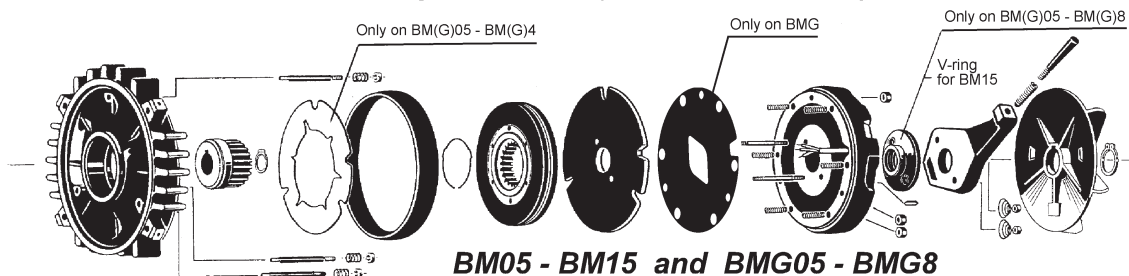

Exploded view of the BM single-disk and double-disk brake (motor sizes 160L-225)

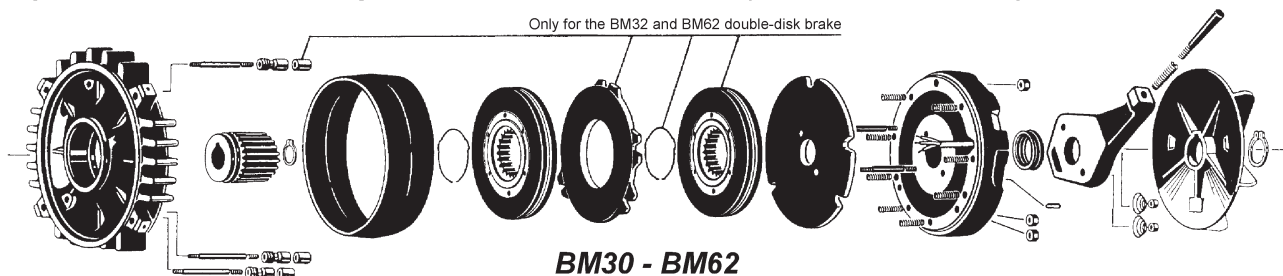

Troubleshooting Chart

PROBLEM	CAUSE	REMEDY
Motor Overheats (Check temperature with instrumentation)	Motor not connected for proper supply voltage	Check connection diagram on conduit box cover and correct the wiring.
	Supply voltage varies outside the allowable tolerance causing an undervoltage or overvoltage condition.	Assure correct supply voltage.
	Insufficient cooling air volume due to: a. Low frequency operation on variable frequency drive. b. Obstructed air flow.	Increase air flow: a. Continuous running auxiliary fan. b. Ensure unobstructed air flow.
	Ambient temperature is too high.	Ensure cool air gets to the motor. Ducting may be required.
	Overload at rated voltage. Unit will draw current in excess of nameplate rating and run below rated speed.	Select a larger unit.
	Motor's allowable duty cycle is exceeded (too many starts per hour required).	The problem may or may not be solved with a larger motor. Contact SEW-Eurodrive.
	Single phasing due to break or loose connection in supply line or blown fuse.	Repair supply lines. Replace fuses.
Motor does not run.	Blown fuse.	Determine and correct cause of failure and replace fuse.
	Motor protection device activated.	Reset protective device. Identify and correct cause for device activation.
	Motor protection device faulty or will not reset.	Check protection device for faults.
Motor will not start or starts sluggishly.	Motor not connected for proper voltage.	Check connection diagram in conduit box cover and correct the wiring.
	Large voltage and/or frequency fluctuation at starting.	Ensure stable power supply.
For reduced voltage starting, motor will not start in Star Connection but will start in Delta connection.	Insufficient torque in Star Connection.	Start motor directly in Delta Connection if possible. Otherwise use a larger motor.
	Faulty contact in Star/Delta starter.	Correct fault condition.
Motor hums and draws high current.	Faulty or defective winding.	Have motor repaired by qualified service shop.
	Rotor dragging.	
Fuses blow or motor overcurrent protection trips immediately.	Short circuit in power supply conductors or in the motor.	Correct the fault condition.
	Motor has ground fault or winding to winding short circuit.	Have motor repaired by qualified service shop.
	Motor improperly connected.	Check connection diagram in conduit box cover and correct the wiring.
Motor runs in wrong direction.	Motor supply leads misconnected.	Switch two supply leads.

Note: If, after proceeding through the Troubleshooting Chart, the motor is found to be defective, contact your nearest SEW-Eurodrive Assembly Center for warranty assistance or replacement parts.