

# Service Manual

Stereo Integrated Amplifier

Amplifier

## SU-G75



Colour

(K)... Black Type

Area

Suffix for Model No.	Area	Colour
(PP1)	U.S.A. and Canada.	(K)

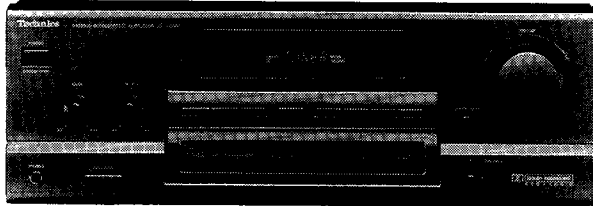

- System No.: **SC-S2600,**  
**SC-S2650,**  
**SC-S160,**  
**SC-S165**

\* Manufactured under license from Dolby Laboratories Licensing Corporation. Additionally licensed under one or more of the following patents: U.S. numbers 3,632,886, 3,746,792 and 3,959,590; Canada numbers 1,004,603 and 1,037,877.

"Dolby" and the double-D symbol are trademarks of Dolby Laboratories Licensing Corporation.

Please file and use this manual together with the service manual for Model No. SU-G95 (PP), Order No. AD9401013C1, and the supplement manual for Model No. SU-G75 (PP), Order No. AD9402038S1 and AD9406179S1.

- Notes:**
- This simplified service manual is provided to indicate the main differences between the original model No. SU-G95 (PP) and the subsequent model No. SU-G75 (PP1).
  - Refer to the printed circuit board (D MAIN P.C.B.) of this service manual.

### LINE-UP OF COMPONENTS

System Name	Unit
*SC-S160 (for Canada)	SU-G75 (PP1) : Amplifier
	ST-K55 (PP) : Tuner
	RS-TR170 (PP) : Cassette deck
SC-S165 (for Canada)	SL-PD665 (PP1) : CD changer
	SB-A16 (PC) : Speakers (Made in MEP)
	SH-KS16 (PC) : Rack (Made in MEP)
	SH-WA816 (PC) : Accessories box

System Name	Unit
*SC-S2600 (for U.S.A.)	SU-G75 (PP1) : Amplifier
	ST-K55 (PP) : Tuner
	RS-TR170 (PP) : Cassette deck
SC-S2650 (for U.S.A.)	SL-PD665 (PP1) : CD changer
	SB-A26 (P) : F. speakers (Made in MEP)
	SB-C926 (P) : C. speakers (Made in MEP)
	SB-S926 (P) : S. speakers (Made in MEP)
	SH-KS26 (P) : Rack (Made in MEP)
	SH-WA26 (P) : Accessories box

**Note:** \* The SB-model speakers and the SH-model rack used with this system have a wood-grain-effect finish.

#### ⚠ WARNING

This service information is designed for experienced repair technicians only and is not designed for use by the general public. It does not contain warnings or cautions to advise non-technical individuals of potential dangers in attempting to service a product. Products powered by electricity should be serviced or repaired only by experienced professional technicians. Any attempt to service or repair the product or products dealt with in this service information by anyone else could result in serious injury or death.

# Technics®

# CHANGES

## ■ SPECIFICATIONS

### SU-G95 (PP)

#### ■ MAIN AMPLIFIER SECTION

**Rated minimum sine wave RMS power output 20 Hz–20 kHz both channels driven 0.9% total harmonic distortion**

130 W per channel (8 Ω)

**1 kHz continuous power output both channels driven**

0.9% total harmonic distortion 135 W per channel (8 Ω)

**Total harmonic distortion**

rated power at 20 Hz–20 kHz 0.9% (8 Ω)

half power at 1 kHz 0.05% (8 Ω)

**Power output at the Dolby Pro Logic operation**

0.9% at 1 kHz Front 2 × 70 W (8 Ω)

Center 70 W (8 Ω)

Rear 70 W (4 Ω)

#### ■ GENERAL

**Power consumption** 270 W, 360 VA

**Power supply** AC 120 V, 60 Hz

**Dimensions (W × H × D)** 430 × 158 × 352 mm

(16-15/16" × 6-7/32" × 13-27/32")

**Weight** 9.4 kg (20.7 lb.)

### SU-G75 (PP1)

#### ■ MAIN AMPLIFIER SECTION

**Rated minimum sine wave RMS power output 40 Hz–20 kHz both channels driven 0.9% total harmonic distortion**

120 W per channel (8 Ω)

**1 kHz continuous power output both channels driven**

0.9% total harmonic distortion 125 W per channel (8 Ω)

**Total harmonic distortion**

rated power at 40 Hz–20 kHz 0.9% (8 Ω)

half power at 1 kHz 0.05% (8 Ω)

**Power output at the Dolby Pro Logic operation**

0.9% at 1 kHz Front 2 × 50 W (8 Ω)

Center 50 W (8 Ω)

Rear 50 W (4 Ω)

#### ■ GENERAL

**Power consumption** 210 W, 280 VA

**Power supply** AC 120 V, 60 Hz

**Dimensions (W × H × D)** 430 × 158 × 352 mm

(16-15/16" × 6-7/32" × 13-27/32")

**Weight** 9.1 kg (20.2 lb.)



## ■ CHANGE IN REPLACEMENT PARTS LIST (SU-G95 Service Manual of pages 30, 33~37.)

- Notes:**
- Mentioned in this parts list is only those different from Model No. SU-G95 (PP). All other parts are the same as for SU-G95 (PP).
  - Important safety notice: Components identified by  $\triangle$  mark have special characteristics important for safety. Furthermore, special parts which have purposes of fire-retardant (resistors), high-quality sound (capacitors), low-noise (resistors), etc. are used. When replacing any of components, be sure to use only manufacturer's specified parts shown in the parts list.

Ref. No.	Change of Part No.		Part Name & Description	Remarks
	SU-G95 (PP)	SU-G75 (PP1)		
<b>INTEGRATED CIRCUIT(S)</b>				
IC602	SVI3204B	SVI3102D	POWER AMP (SURROUND/CENTER)	
<b>TRANSISTOR(S)</b>				
Q602	2SA1309AIRTA	—	TRANSISTOR	Deletion
Q651	2SA1309AIRTA	—	TRANSISTOR	Deletion
Q652	2SC3311AIRTA	—	TRANSISTOR	Deletion
Q731	2SB1357DEFTA	—	TRANSISTOR	Deletion
Q732, 733	2SC3311AIRTA	—	TRANSISTOR	Deletion
Q734	2SD2037DEFTA	—	TRANSISTOR	Deletion
Q735	2SA992EFPTA	—	TRANSISTOR	Deletion
Q737	2SA992EFPTA	—	TRANSISTOR	Deletion
<b>DIODE(S)</b>				
D605	MA165	—	DIODE	Deletion
D607, 608	MA4033TA	—	DIODE	Deletion
D654	MA165	—	DIODE	Deletion
D656	MA4047MTA	—	DIODE	Deletion
D731	MA4360MTA	—	DIODE	Deletion
D732, 733	MA165	—	DIODE	Deletion
D907	MA165	—	DIODE	Deletion

Ref. No.	Change of Part No.		Part Name & Description	Remarks
	SU-G95 (PP)	SU-G75 (PP1)		
<b>TRANSFORMER(S)</b>				
T701	RTP1P5C016-V	RTP1P5C015	POWER TRANSFORMER (MAIN)	△
<b>RELAY(S)</b>				
RL602, 603	RSY0013M-0	—	RELAY	△ Deletion
<b>JACK(S) AND TERMINAL(S)</b>				
JK602	RJR0054	—	FRONT SPEAKERS B TERMINAL	Deletion
<b>RESISTORS</b>				
R626, 627	—	ERD25FVJ180T	1/4W 18Ω	Addition
R630	ERDS2TJ472	—	—	Deletion
R632	ERDS2TJ103	—	—	Deletion
R634	ERDS2TJ222	—	—	Deletion
R636	ERDS1FVJ821T	—	—	Deletion
R665	ERDS2TJ563	—	—	Deletion
R666	ERDS2TJ104	—	—	Deletion
R667	ERD25FJ101	—	—	Deletion
R671	ERDS2TJ103	—	—	Deletion
R674	ERDS2TJ473	—	—	Deletion
R676	ERDS2TJ223	—	—	Deletion
R677	ERDS2TJ103	—	—	Deletion
R678	ERDS1FVJ821T	—	—	Deletion
R731	ERD25FVJ180T	—	—	Deletion
R732	ERDS2TJ153	—	—	Deletion
R733	ERDS2TJ273	—	—	Deletion
R734	ERDS2TJ223	—	—	Deletion
R735	ERDS2TJ333	—	—	Deletion
R739	ERD25FVJ180T	—	—	Deletion
R740	ERDS2TJ393	—	—	Deletion
R742	ERDS2TJ393	—	—	Deletion
R743	ERDS2TJ183T	—	—	Deletion
R793, 794	ERDS2TJ223	—	—	Deletion
R797	ERDS2TJ682T	ERDS2TJ153	1/4W 15kΩ	
<b>CAPACITORS</b>				
C659, 660	ECBT1H151KB5	ECBT1H821KB5	50V 820pF	
C665	ECA1HM470B	—	—	Deletion
C667	ECEA1JU220	ECA1JM330B	63V 33μF	
C669	ECEA2AN2R2SB	—	—	Deletion
C703, 704	ECET1K123VWK	ECES1K752VUX	80V 7500μF	
C705, 706	ECA1JM222B	ECA1HM222B	50V 2200μF	
C731, 732	ECKR1HT03ZF5	—	—	Deletion
<b>CABINET AND CHASSIS</b>				
6	RGR0186B-A	RGR0186A-A5	REAR PANEL	
21	RFKGUG95PP-K	RFKGUG75PP-K	FRONT PANEL ASS'Y	
23	RGU1027-K	RGU1027C-K	SELECTOR/PRO. LOGIC BUTTON	
<b>PACKING MATERIAL</b>				
P1	RPG1948	RPG1947	PACKING CASE	
<b>ACCESSORIES</b>				
A1	RFKSHWA22P-K	—	INSTRUCTION MANUAL ASS'Y	SC-S3500/S3550 for U.S.A. Deletion
	RFKSHWA32P-K	—	INSTRUCTION MANUAL ASS'Y	SC-S4500/S4505/S4550 for U.S.A. Deletion
	RFKSHWA42PCK	—	INSTRUCTION MANUAL ASS'Y	SC-S2500/S2550 for CANADA Deletion
	RFKSHWA62PCK	—	INSTRUCTION MANUAL ASS'Y	SC-S3500/S3550 for CANADA Deletion
A1*	—	RFKSHWA26P-K	INSTRUCTION MANUAL ASS'Y	SC-S2600/S2650 for U.S.A. Addition
	—	RFKSHWA816PC	INSTRUCTION MANUAL ASS'Y	SC-S160/S165 for CANADA Addition

Ref. No.	Change of Part No.		Part Name & Description	Remarks
	SU-G95 (PP)	SU-G75 (PP1)		
A4	RAK-SA112MH	—	REMOTE CONTROL TRANSMITTER	SC-S2500/S2550 for CANADA Deletion
	RAK-SA723MH	—	REMOTE CONTROL TRANSMITTER	SC-S3500/S3550/4500/S4505/S4550 for U.S.A. SC-S3500/S3550 for CANADA Deletion
A4*	—	RAK-SA112MH	REMOTE CONTROL TRANSMITTER	SC-S160/S165 for CANADA Addition
	—	RAK-SA601MH	REMOTE CONTROL TRANSMITTER	SC-S2600/S2650 for U.S.A. Addition
A4-1	RKK0057-K	—	BATTERY COVER (FOR R/C TRANSMITTER)	SC-S2500/S2550 for CANADA Deletion
	RKK0020-K	—	BATTERY COVER (FOR R/C TRANSMITTER)	SC-S3500/S3550/4500/S4505/S4550 for U.S.A. SC-S3500/S3550 for CANADA Deletion
A4-1*	—	RKK0057-K	BATTERY COVER (FOR R/C TRANSMITTER)	SC-S160/S165 for CANADA Addition
	—	RKK0020-K	BATTERY COVER (FOR R/C TRANSMITTER)	SC-S2600/S2650 for U.S.A. Addition
A6	XTN3+10AFZ	XTN3+12AFZ	SCREW	

- Notes:**
- Parts identified by the "\*" mark are contained in the carton (accessories box) of SH-WA26 (P) or SH-WA816 (PC) listed in the table "LINE-UP OF COMPONENTS" on page 1.
  - Refer to the packaging on page 4 of the Technical Information for Model No. SH-WA26/SH-WA36/SH-WA42/SH-WA816/SH-WA826/SH-WA836, Order No. AD9501012T1.

**WIRING CONNECTION DIAGRAM (SU-G95 Service Manual of page 22.)**

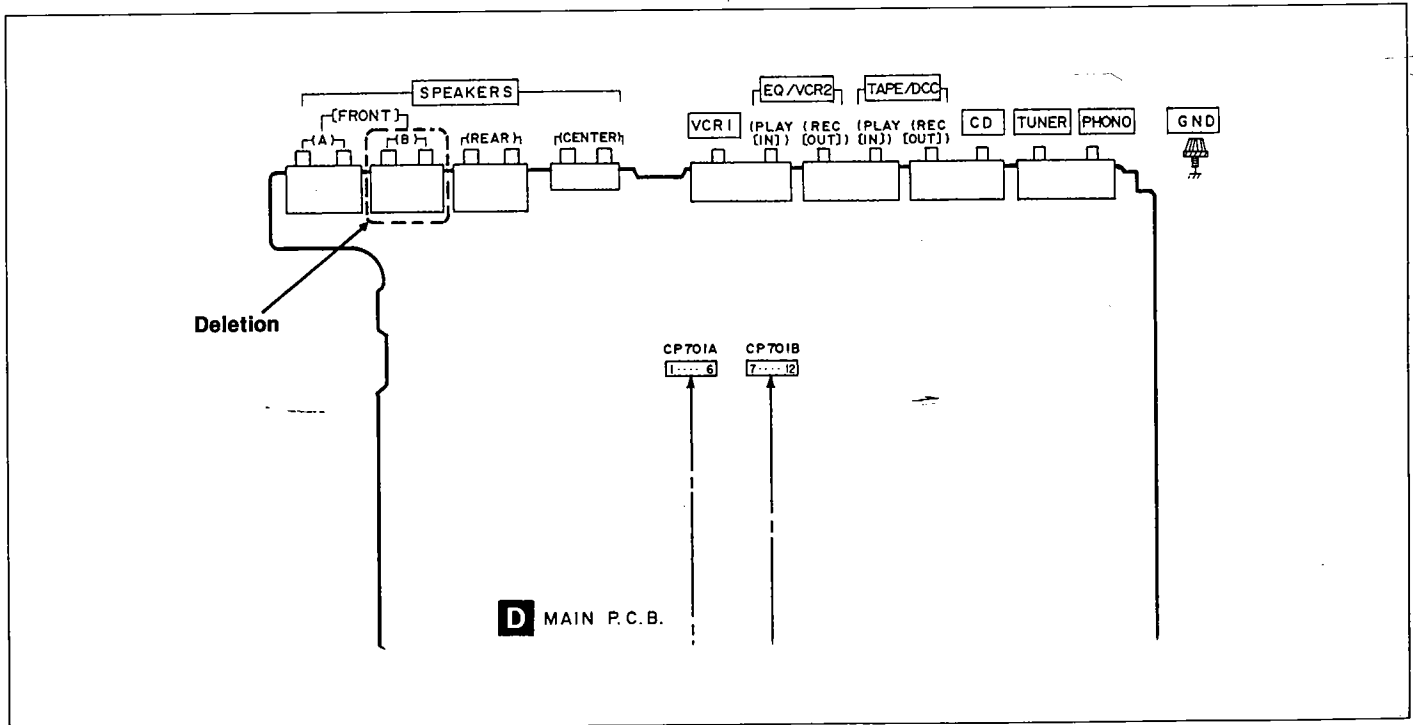

**BLOCK DIAGRAM (SU-G95 Service Manual of pages 11,12.)**

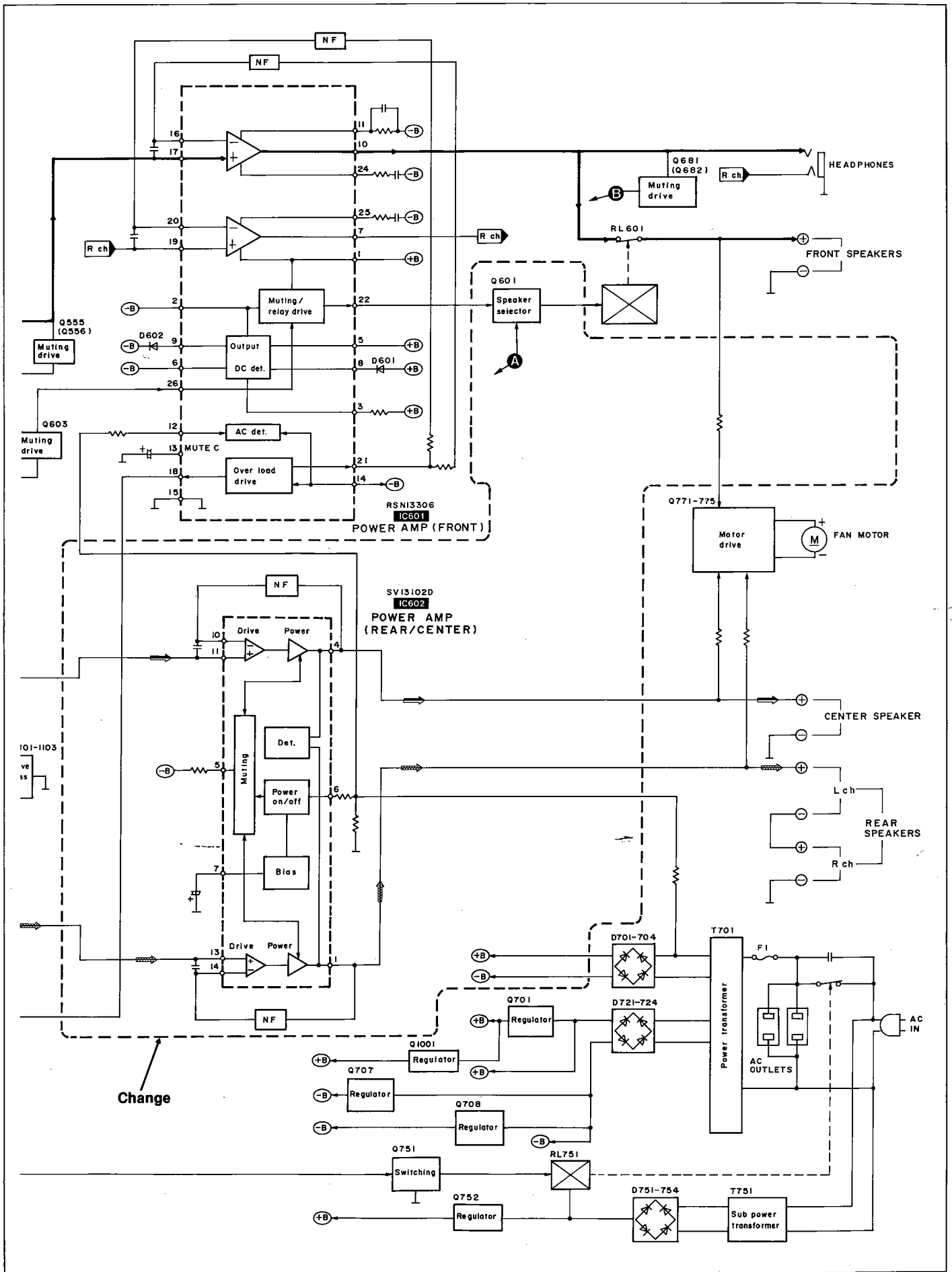

**SCHEMATIC DIAGRAM (SU-G95 Service Manual of pages 14~21.)**

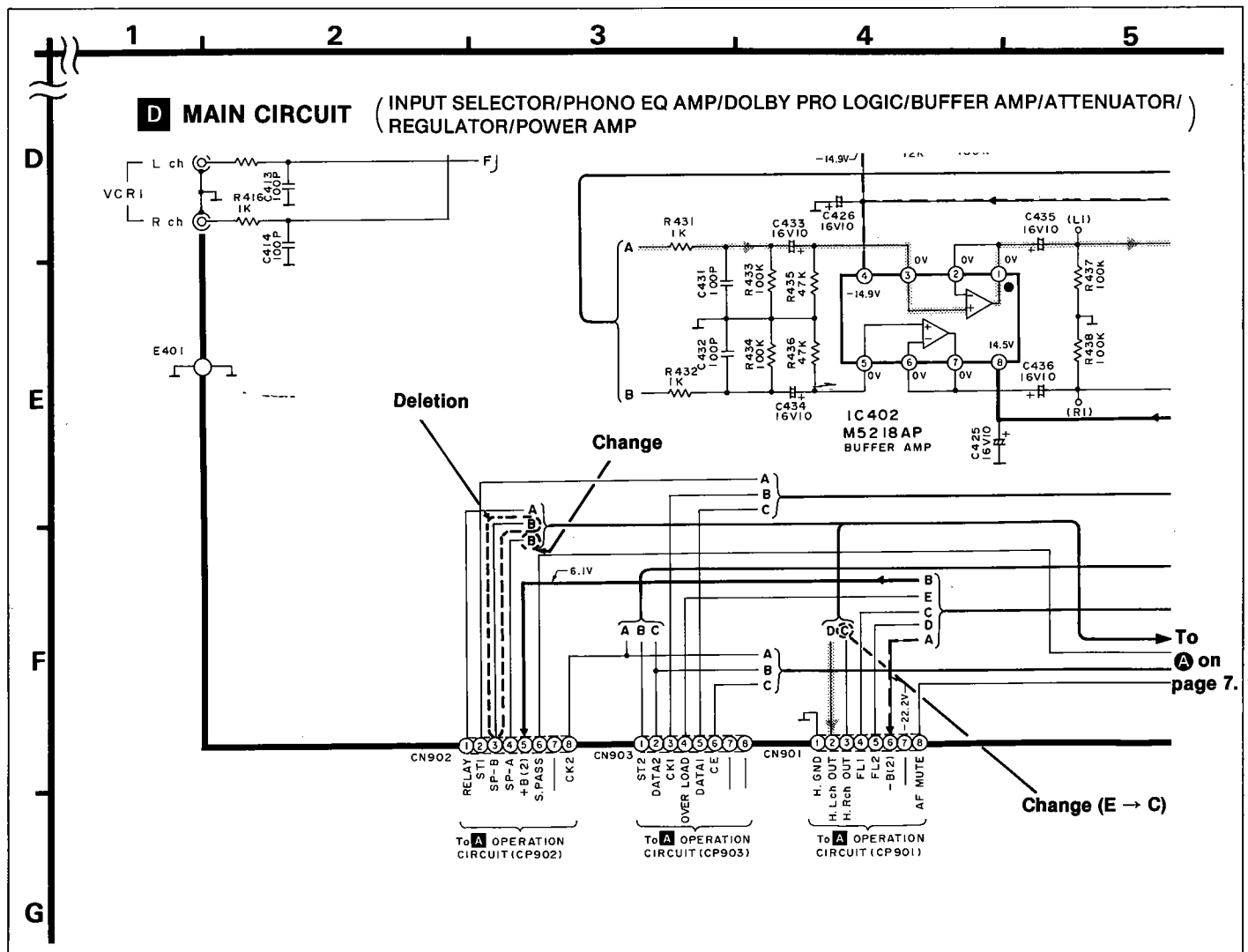
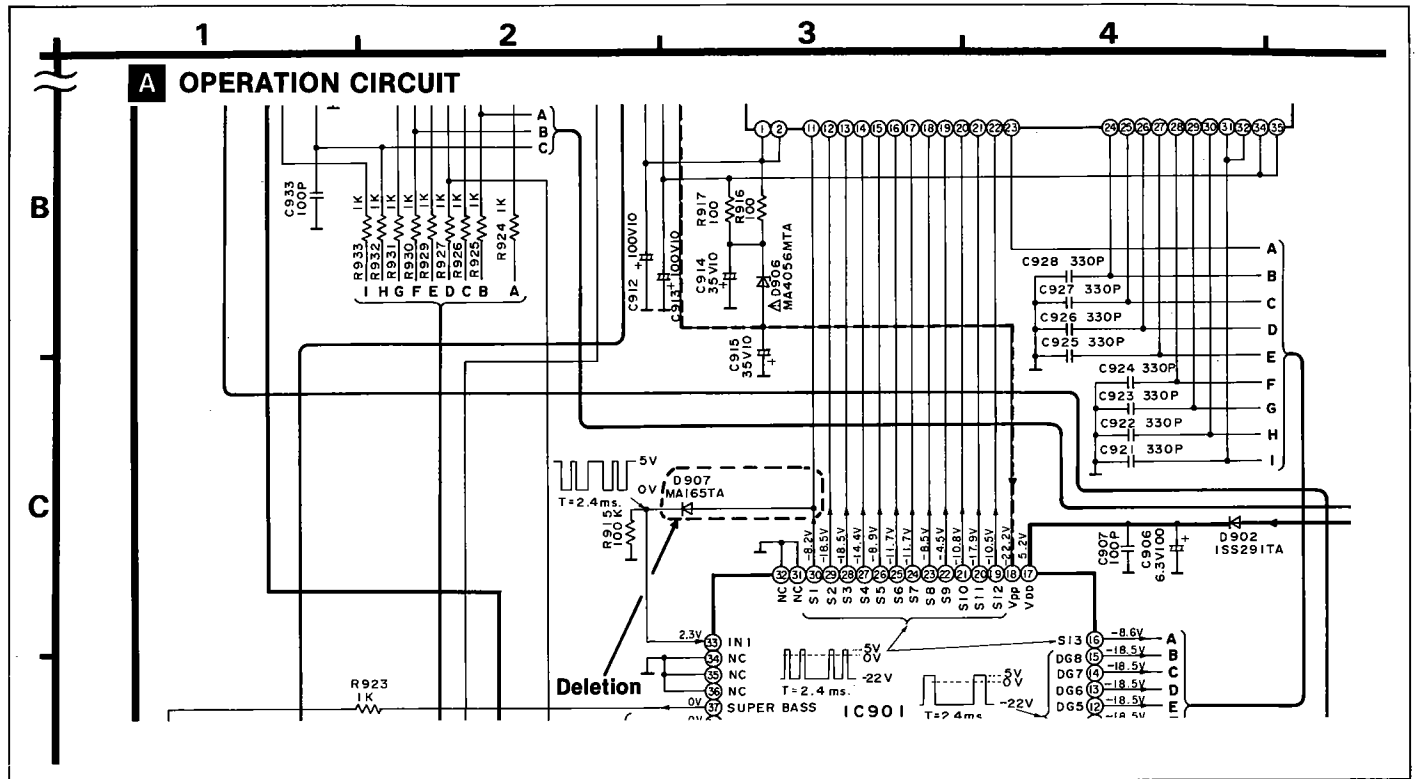

**E** MUTING CIRCUIT

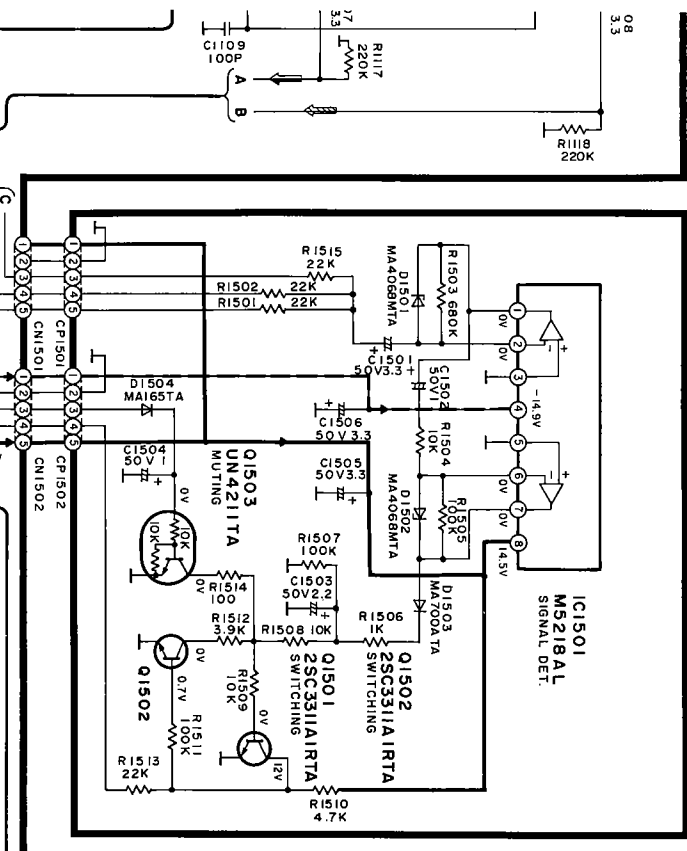

**D** MAIN CIRCUIT (INPUT SELECTOR/PHONO EQ AMP/DOLBY PRO LOGIC/BUFFER AMP/ATTENUATOR/REGULATOR/POWER AMP)

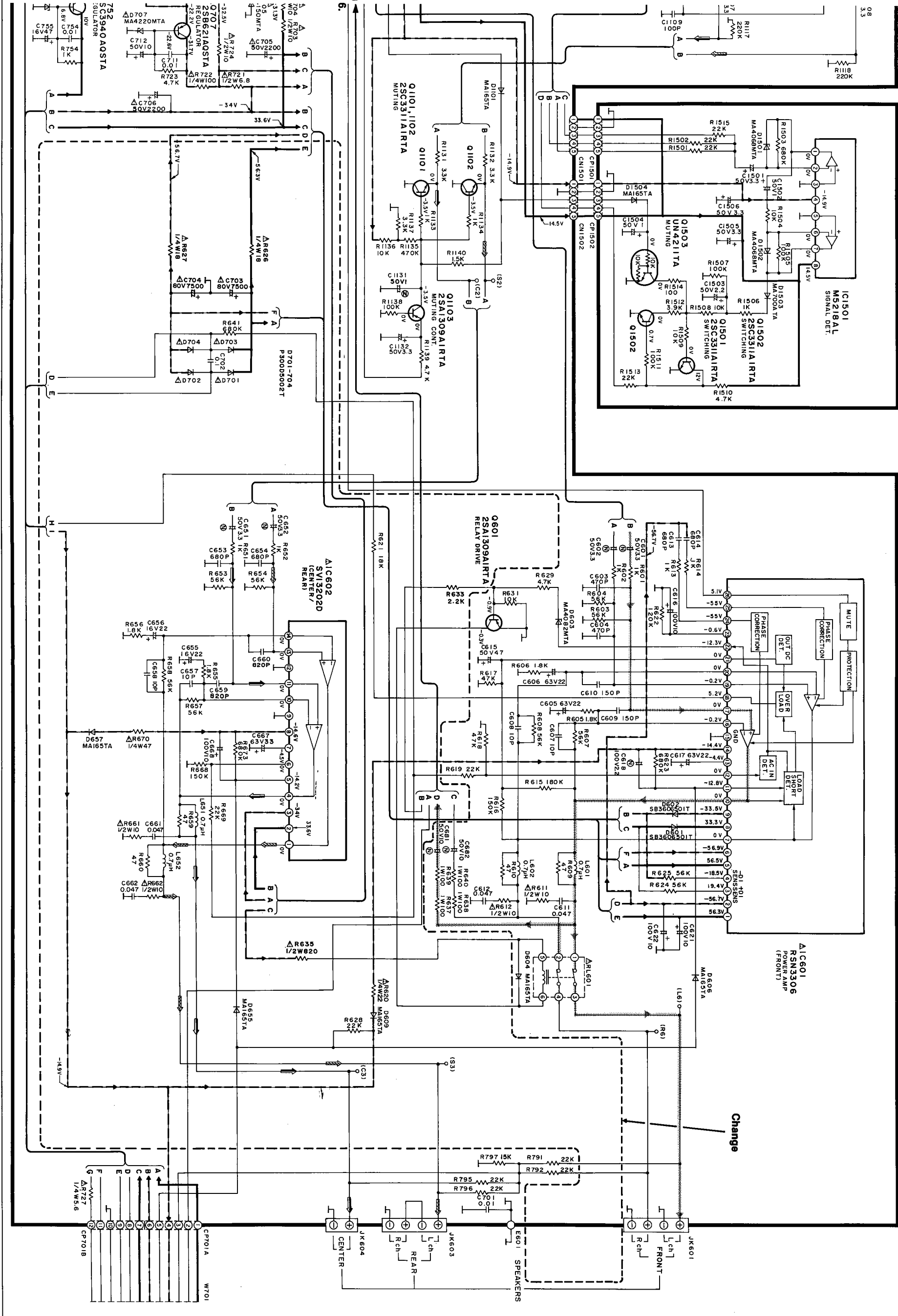

To page 6.

SU-G75 SU-G75

**D** MAIN P.C.B. (REP1739A-M)

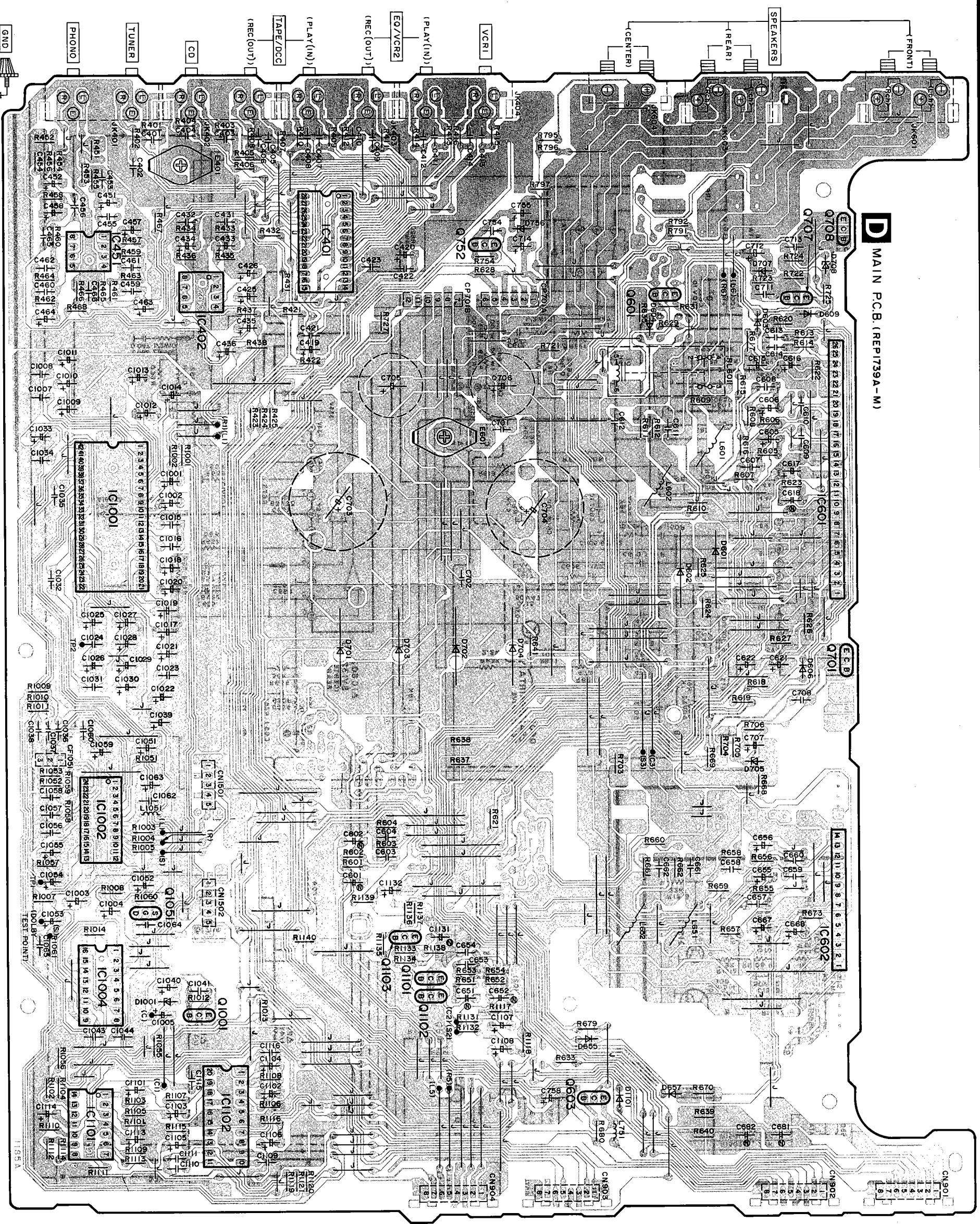



# Service Manual

Stereo Integrated Amplifier

Amplifier  
**SU-G95**

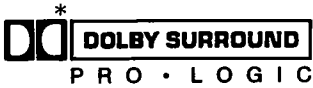

Colour

(K)... Black Type

Area

Suffix for Model No.	Area	Colour
(PP)	U.S.A. and Canada.	(K)

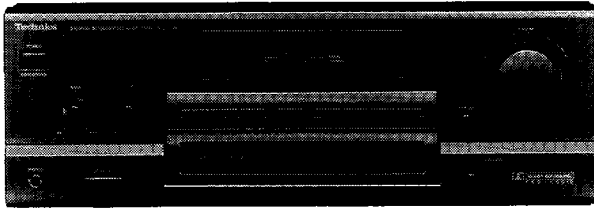

• System No.: SC-S3500, SC-S4505 } Refer to  
SC-S3550, SC-S4550 } page 3.  
SC-S4500 }

\* Manufactured under license from Dolby Laboratories Licensing Corporation. Additionally licensed under one or more of the following patents: U.S. numbers 3,632,886, 3,746,792 and 3,959,590; Canada numbers 1,004,603 and 1,037,877.

"Dolby" and the double-D symbol are trademarks of Dolby Laboratories Licensing Corporation.

## SPECIFICATIONS (IHF '78)

### ■ MAIN AMPLIFIER SECTION

**Rated minimum sine wave RMS power output 20 Hz–20 kHz both channels driven 0.9% total harmonic distortion**  
130 W per channel (8 Ω)

**1 kHz continuous power output both channels driven 0.9% total harmonic distortion**  
135 W per channel (8 Ω)

**Total harmonic distortion**  
rated power at 20 Hz–20 kHz 0.9% (8 Ω)  
half power at 1 kHz 0.05% (8 Ω)

**Power output at the Dolby Pro Logic operation 0.9% at 1 kHz**

Front	2 × 70 W (8 Ω)
Center	70 W (8 Ω)
Rear	70 W (4 Ω)

**SMPTE intermodulation distortion** 0.5 % (8 Ω)

**Dynamic headroom** 2.0 dB (8 Ω)

**Low frequency damping factor** 30 (8 Ω)

**Load impedance**

A or B	8 Ω
Center	8 Ω
Rear	4 Ω

### ■ PRE AMPLIFIER SECTION

**Input sensitivity/Impedance**

PHONO	0.3 mV (2.5 mV, IHF '66)/47 kΩ
TUNER, CD, TAPE/DCC, VCR 1, EQ/VCR 2	15 mV (150 mV, IHF '66)/22 kΩ

S/N (IHF, A)

PHONO 70 dB (78 dB, IHF '66)  
TUNER, CD, TAPE/DCC, VCR 1, EQ/VCR 2 75 dB (90 dB, IHF '66)

Frequency response

PHONO RIAA standard curve ±0.8 dB  
TUNER, CD, TAPE/DCC, VCR 1, EQ/VCR 2 10 Hz–70 kHz, ±3 dB

Tone controls

BASS 50 Hz, +10 dB to –10 dB  
TREBLE 20 kHz, +10 dB to –10 dB  
Super bass 80 Hz, +6 dB/oct

### ■ GENERAL

**Power consumption** 270 W, 360 VA  
**Power supply** AC 120 V, 60 Hz  
**Dimensions (W × H × D)** 430 × 158 × 352 mm  
(16-15/16" × 6-7/32" × 13-27/32")  
**Weight** 9.4 kg (20.7 lb.)

Notes:

- Design and specifications are subject to change without notice.  
Weight and dimensions are approximate.
- Total harmonic distortion is measured by the digital spectrum analyzer.

# Technics

## CONTENTS

	Page		Page
SAFETY PRECAUTION .....	2	WIRING CONNECTION DIAGRAM.....	22
PROTECTION CIRCUITRY.....	2	PRINTED CIRCUIT BOARDS .....	23~27
BEFORE REPAIR AND ADJUSTMENT .....	2	TERMINAL GUIDE OF IC'S, TRANSISTORS AND DIODES .....	28
LINE-UP COMPONENTS .....	3	TERMINAL FUNCTION OF IC.....	29
FRONT PANEL CONTROLS.....	3	REPLACEMENT PARTS LIST.....	30
DISASSEMBLY INSTRUCTIONS.....	4~8	CABINET PARTS LOCATION .....	31, 32
FAN MOTOR TROUBLE SHOOTING GUIDE.....	9	REPLACEMENT PARTS LIST .....	33, 34
BLOCK DIAGRAM.....	10~12	RESISTORS AND CAPACITORS.....	35~37
SCHEMATIC DIAGRAM .....	13~21	PACKAGING .....	37

**Note:** Refer to the placement, Equipment connections and Remote control operation of Service manual for Model No. ST-K55 (PP), Order No. AD9401001C1.

## SAFETY PRECAUTION (This "safety precaution" is applied only in U.S.A.)

1. Before servicing, unplug the power cord to prevent an electric shock.
2. When replacing parts, use only manufacturer's recommended components for safety.
3. Check the condition of the power cord. Replace if wear or damage is evident.
4. After servicing, be sure to restore the lead dress, insulation barriers, insulation papers, shields, etc.
5. Before returning the serviced equipment to the customer, be sure to make the following insulation resistance test to prevent the customer from being exposed to a shock hazard.

### INSULATION RESISTANCE TEST

1. Unplug the power cord and short the two prongs of the plug with a jumper wire.
2. Turn on the power switch.
3. Measure the resistance value with ohmmeter between the jumpered AC plug and each exposed metal cabinet part, such as screwheads, antenna control shafts, handle brackets, etc. Equipment with antenna terminals should read between  $3M\Omega$  and  $5.2M\Omega$  to all exposed parts. (Fig. A) Equipment without antenna terminals should read approximately infinity to all exposed parts. (Fig. B)

**Note:** Some exposed parts may be isolated from the chassis by design. These will read infinity.

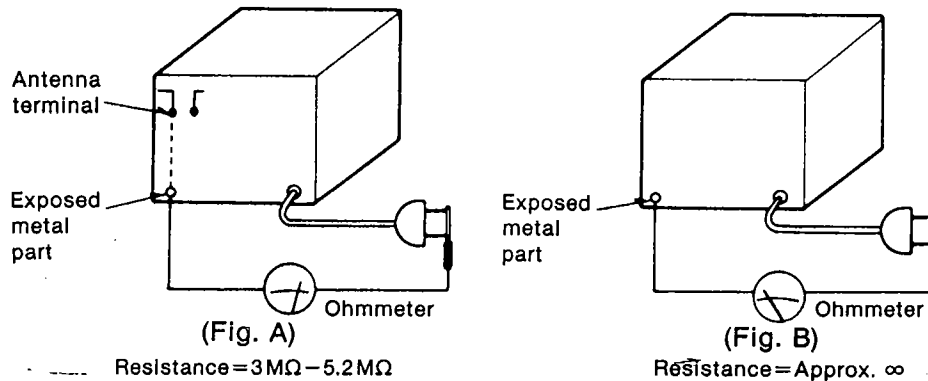

4. If the measurement is outside the specified limits, there is a possibility of a shock hazard. The equipment should be repaired and rechecked before it is returned to the customer.

## PROTECTION CIRCUITRY

The protection circuitry may have operated if either of the following conditions is noticed:

- No sound is heard when the power is turned on.
- Sound stops during a performance.

The function of this circuitry is to prevent circuitry damage if, for example, the positive and negative speaker connection wires are "shorted", or if speaker systems with an impedance less than the indicated rated impedance of the amplifier are used.

If this occurs, follow the procedure outlines below:

1. Turn off the power.
2. Determine the cause of the problem and correct it.
3. Turn on the power once again after one minute.

### Note:

When the protection circuitry functions, the unit will not operate unless the power is first turned off and then on again.

## BEFORE REPAIR AND ADJUSTMENT

Disconnect AC power, Discharge both Power Supply Capacitors C703 and C704 (80V 1200 $\mu$ F), C705 and C706 (63V 2200 $\mu$ F) through a 10 $\Omega$ , 5W resistor to ground. DO NOT SHORT-CIRCUIT DIRECTLY (with a screwdriver blade, for instance), as this may destroy solid state devices. After repairs are completed, restore power gradually using a variac, to avoid overcurrent.

Current consumption at 120V, 60Hz in NO SIGNAL mode should be 410~810mA.

## LINE-UP OF COMPONENTS

System Name	Unit
*SC-S2500 (for Canada)	ST-K55 (PP) : Tuner
	SU-G95 (PP) : Amplifier
	— : Graphic equalizer
	RS-TR170 (PP) : Cassette deck
	SL-PD665 (PP) : CD changer
	SB-A35 (PC) : Speakers (Made in MEP)
	SH-KS35 (PC) : Rack (Made in MEP)
SC-S2550 (for Canada)	SH-WA52 (PC) : Accessories box
	ST-K55 (PP) : Tuner
	SU-G95 (PP) : Amplifier
	SH-8017 (PP) : Graphic equalizer
	RS-TR170 (PP) : Cassette deck
	SL-PD665 (PP) : CD changer
	SB-A55 (P) : F. speakers (Made in MEP)
*SC-S3500 (for U.S.A.)	SB-C55 (P) : C. speakers (Made in MEP)
	SB-S35 (P) : S. speakers (Made in MEP)
	SH-KS55 (P) : Rack (Made in MEP)
	SH-WA22 (P) : Accessories box
	ST-K55 (PP) : Tuner
	SU-G95 (PP) : Amplifier
	SH-8017 (PP) : Graphic equalizer
SC-S3550 (for U.S.A.)	RS-TR270 (PP) : Cassette deck
	SL-PD665 (PP) : CD changer
	SB-A55 (PC) : Speakers (Made in MEP)
	SH-KS55 (PC) : Rack (Made in MEP)
	SH-WA62 (PC) : Accessories box
	ST-K55 (PP) : Tuner
	SU-G95 (PP) : Amplifier
*SC-S4500 (for Canada)	SH-GS71 (P1) : Graphic equalizer
	RS-TR270 (PP) : Cassette deck
	SL-PD665 (PP) : CD changer
	SB-A65 (P) : F. speakers (Made in MEP)
	SB-C55 (P) : C. speakers (Made in MEP)
	SB-S35 (P) : S. speakers (Made in MEP)
	SH-KS85 (P) : Rack (Made in MEP)
SC-S4505 (for U.S.A.)	SH-WA32 (P) : Accessories box
	ST-K55 (PP) : Tuner
	SU-G95 (PP) : Amplifier
	SH-GS91 (P) : D. sound processor
	RS-TR270 (PP) : Cassette deck
	SL-PD665 (PP) : CD changer
	SB-A65 (P) : F. speakers (Made in MEP)
SC-S4550 (for U.S.A.)	SB-C55 (P) : C. speakers (Made in MEP)
	SB-S35 (P) : S. speakers (Made in MEP)
	SH-KS65 (P) : Rack (Made in MEP)
	SH-WA32 (P) : Accessories box

Note: \* The SB-model speakers and the SH-model rack used with this system have a wood-grain-effect finish.

## FRONT PANEL CONTROLS

- | No. | Name   |
|-----|--|
| ①   | Power "STANDBY $\odot$ /ON" switch (POWER, STANDBY $\odot$ /ON)<br>Press to switch the unit from on to standby mode or vice versa. In standby mode, the unit is still consuming a small amount of power. |
| ②   | Bass control (BASS)  |
| ③   | Treble control (TREBLE)  |
| ④   | Remote control signal receptor (SENSOR)  |
| ⑤   | Display  |
| ⑥   | Test signal ON/OFF button (TEST)   |
| ⑦   | Center level adjust button (CENTER LEVEL)  |
| ⑧   | Rear level adjust button (REAR LEVEL)  |
| ⑨   | Super bass ON/OFF button   |
| ⑩   | Volume control (VOLUME)  |
| ⑪   | Headphone jack (PHONES)  |
| ⑫   | Speaker ON/OFF button (SPEAKERS)   |
| ⑬   | DOLBY PRO LOGIC SURROUND ON/OFF button (SURROUND)  |
| ⑭   | DOLBY PRO LOGIC 3 STEREO ON/OFF button (3 STEREO)  |
| ⑮   | Center mode select button (CENTER MODE)  |
| ⑯   | Input select buttons   |
| ⑰   | Balance control (BALANCE)  |

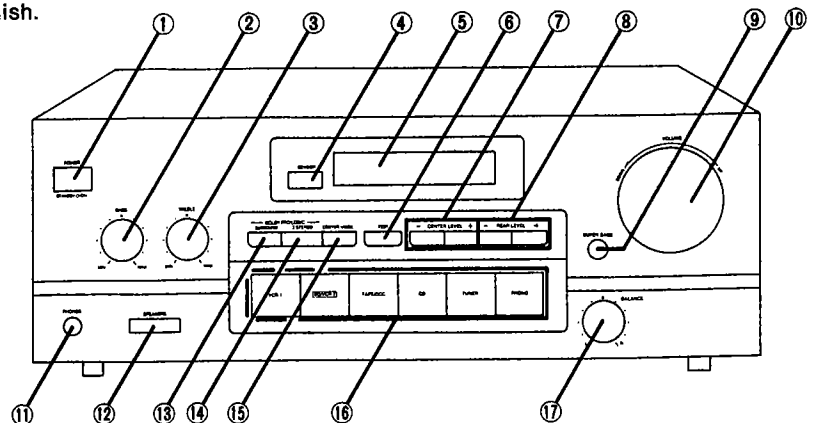

# DISASSEMBLY INSTRUCTIONS

## "ATTENTION SERVICER"

Some chassis components may have sharp edges. Be careful when disassembling and servicing.

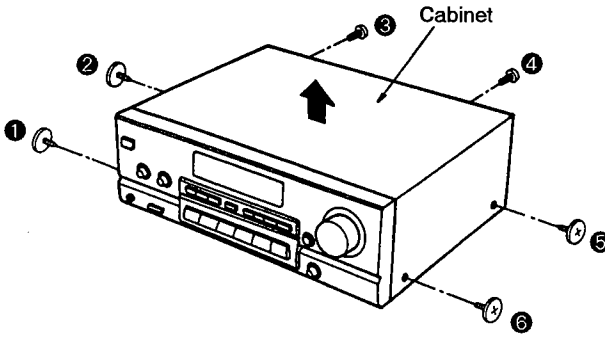
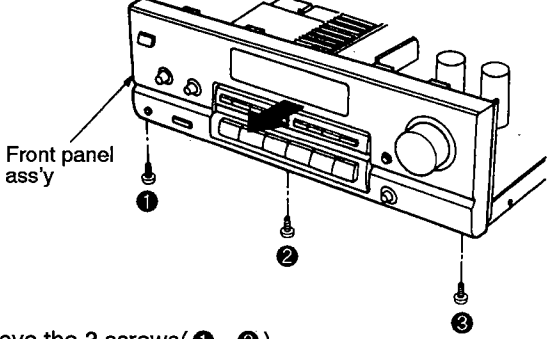
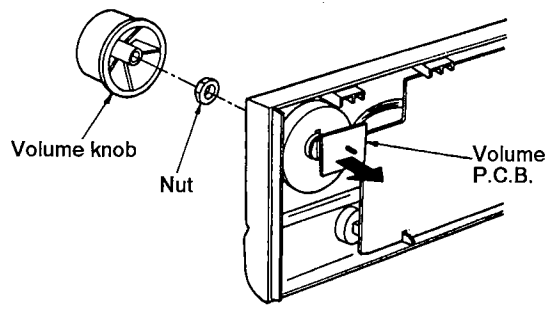
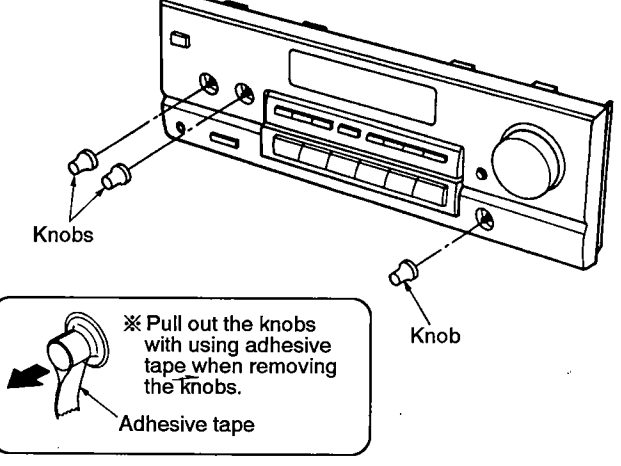
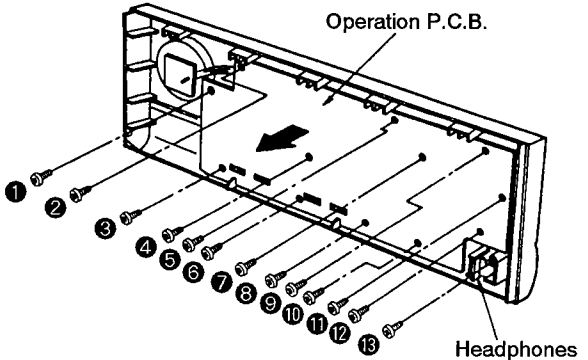
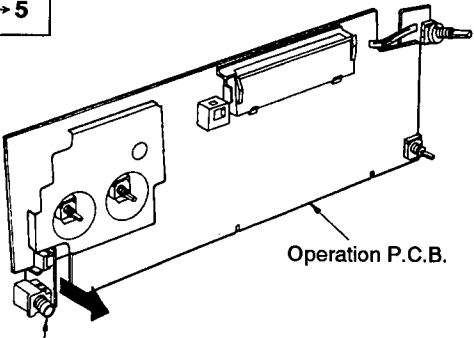
<p><b>Ref.No.</b> 1</p> <p><b>Procedure</b> 1</p>	<p><b>Removal of the cabinet</b></p>	<p><b>Ref.No.</b> 2</p> <p><b>Procedure</b> 1→2</p>	<p><b>Removal of the front panel ass'y</b></p>
 <p>• Remove the 6 screws(①~⑥).</p>		 <p>1. Remove the 3 screws(①~③). 2. Remove the front panel ass'y in the direction of arrow.</p>	
<p><b>Ref.No.</b> 3</p> <p><b>Procedure</b> 1→2→3</p>	<p><b>Removal of the volume P.C.B.</b></p>	<p><b>Ref.No.</b> 4</p> <p><b>Procedure</b> 1→2→4</p>	<p><b>Removal of the operation P.C.B.</b></p>
 <p>1. Pull out the volume knob:- 2. Remove the nut. 3. Remove the volume P.C.B. in the direction of arrow.</p>		 <p>1. Pull out the 3 knobs.</p>	
<p><b>Ref.No.</b> 5</p> <p><b>Procedure</b> 1→2→4→5</p>	<p><b>Removal of the headphones jack P.C.B.</b></p>	 <p>2. Remove the 13 screws(①~⑬).</p>	
 <p>• Pull out the headphones jack P.C.B. in the direction of arrow.</p>			

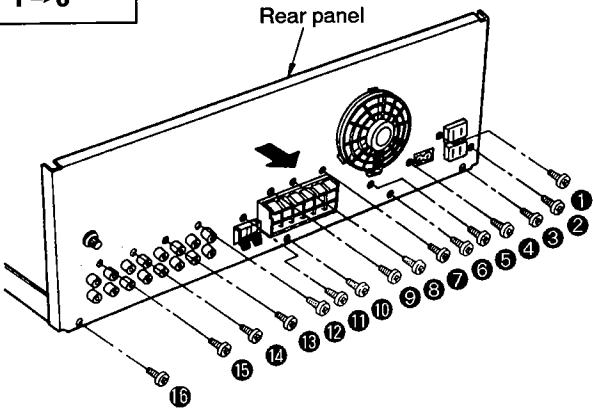
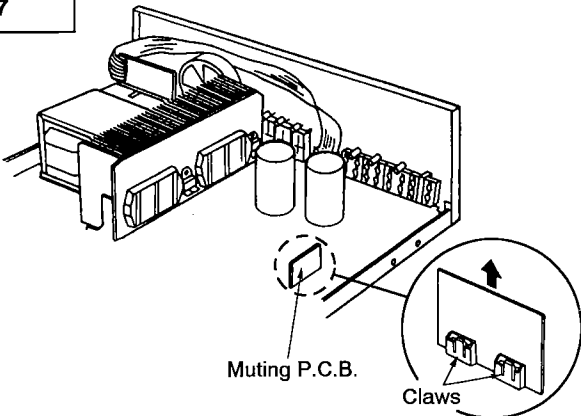
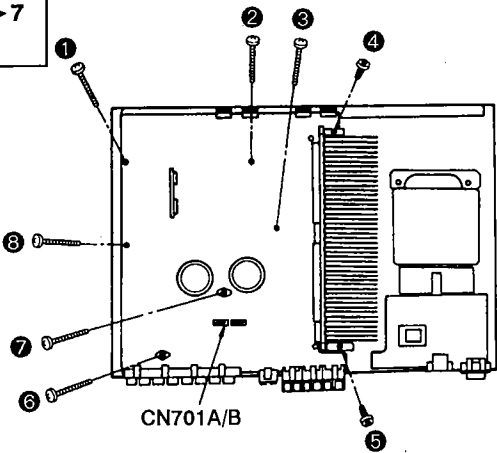
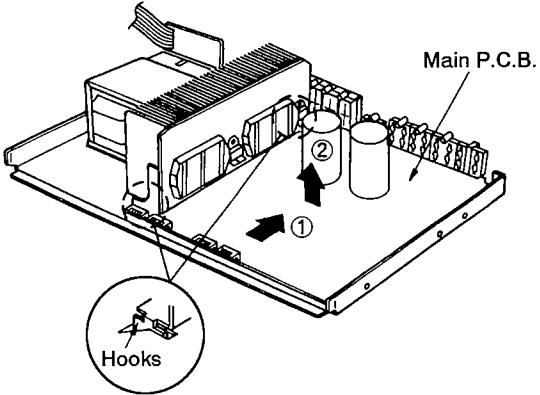
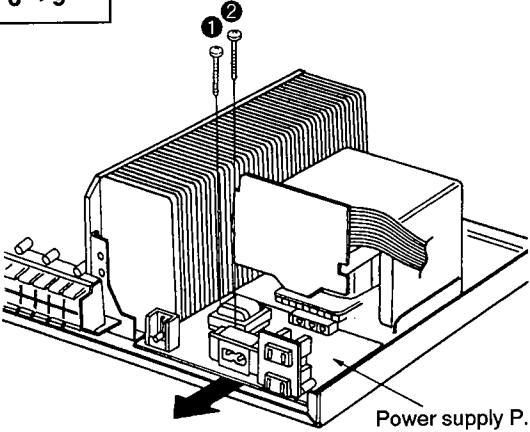
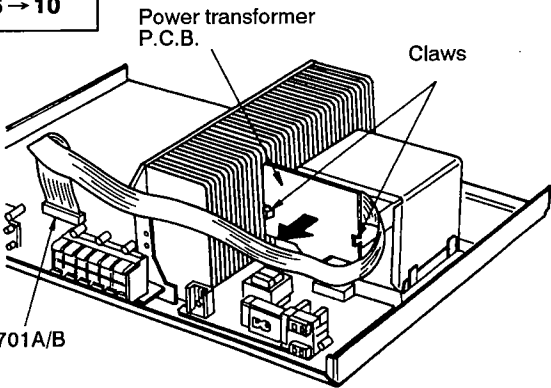
<p><b>Ref.No.</b> 6</p>	<p><b>Removal of the rear panel</b></p>	<p><b>Ref.No.</b> 7</p>	<p><b>Removal of the muting P.C.B.</b></p>
<p><b>Procedure</b> 1 → 6</p>	 <p>1. Remove the 16 screws (① ~ ⑯).</p> <p>2. Remove the rear panel in the direction of arrow.</p>	<p><b>Procedure</b> 1 → 7</p>	 <p>• Release the 2 claws and then remove the muting P.C.B. in the direction of arrow.</p>
<p><b>Ref.No.</b> 8</p>	<p><b>Removal of the main P.C.B.</b></p>	<p><b>Ref.No.</b> 10</p>	<p><b>Removal of the power transformer P.C.B.</b></p>
<p><b>Procedure</b> 1 → 2 → 6 → 7 → 8</p>	 <p>1. Remove the 1 flat cable(CN701A/B).</p> <p>2. Remove the 8 screws(① ~ ⑧).</p>	<p><b>Procedure</b> 1 → 6 → 10</p>	 <p>3. Release the 2 hooks by sliding the main P.C.B. in the direction of arrow ①, and then remove the main P.C.B. in the direction of arrow ②.</p>
<p><b>Ref.No.</b> 9</p>	<p><b>Removal of the power supply P.C.B.</b></p>	<p><b>Procedure</b> 1 → 6 → 9</p>	<p><b>Procedure</b> 1 → 6 → 10</p>
<p><b>Procedure</b> 1 → 6 → 9</p>	 <p>1. Remove the 2 screws(①, ②).</p> <p>2. Remove the power supply P.C.B. in the direction of arrow.</p>	<p><b>Procedure</b> 1 → 6 → 10</p>	 <p>1. Remove the 1 flat cable(CN701A/B).</p> <p>2. Release the 2 claws.</p> <p>3. Remove the power transformer P.C.B. in the direction of arrow.</p>

<b>Ref.No.</b> 11	<b>Removal of the power transformer</b>
<b>Procedure</b> 1 → 6 → 9 → 10 → 11	
	<ul style="list-style-type: none"> <li>Remove the 4 screws( ① ~ ④ ).</li> </ul>

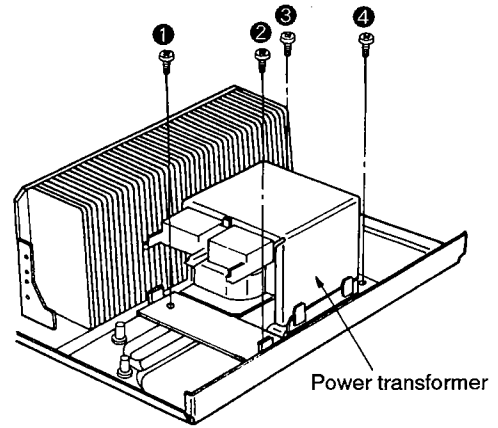

<b>Ref.No.</b> 12	<b>Removal of the power IC and regulator transistor</b>
<b>Procedure</b> 1 → 2 → 6 → 7 → 8 → 12	
	<ol style="list-style-type: none"> <li>Unsolder the power IC or regulator transistor.</li> <li>Remove the 6 screws( ① ~ ⑥ ).</li> <li>Remove the 2 transistor holders.</li> </ol> <ul style="list-style-type: none"> <li><b>When mounting the power IC or regulator transistor.</b> Apply silicone compound(RFKX0002) to the rear side of power IC or regulator transistor.</li> </ul>

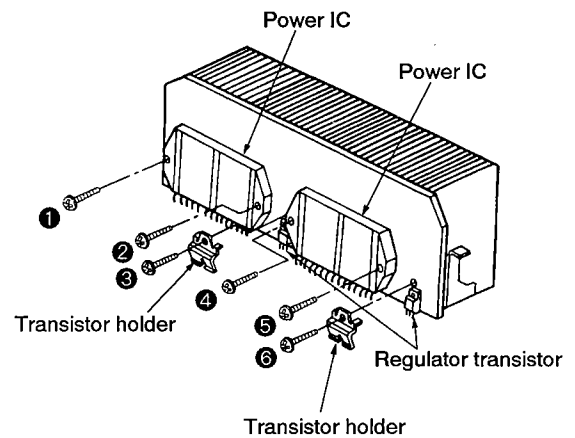

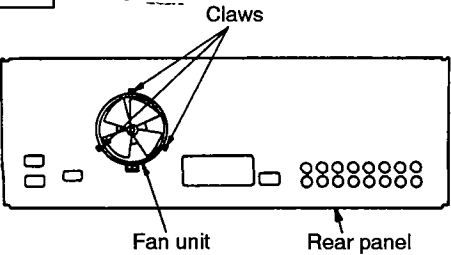
<b>Ref.No.</b> 13	<b>Removal of the cooling fan motor</b>
<b>Procedure</b> 1 → 6 → 13	
	 <p style="text-align: center;">( Fig. 1 )</p> <ol style="list-style-type: none"> <li>Release the 3 claws. (See Fig. 1)</li> <li>Insert a screwdriver at the foot of the fan. Force it out of the motor shaft. (See Fig. 2)</li> <li>Remove the fan cap by used ⊖ screwdriver. (See Fig. 3)</li> <li>Remove the fan terminal cap in the direction of arrow. (See Fig. 4)</li> <li>Remove the motor from the fan case. (See Fig. 5)</li> <li>When mounting the motor, align the fan casing's projection with the hole of the motor. (See Fig. 6)</li> </ol>

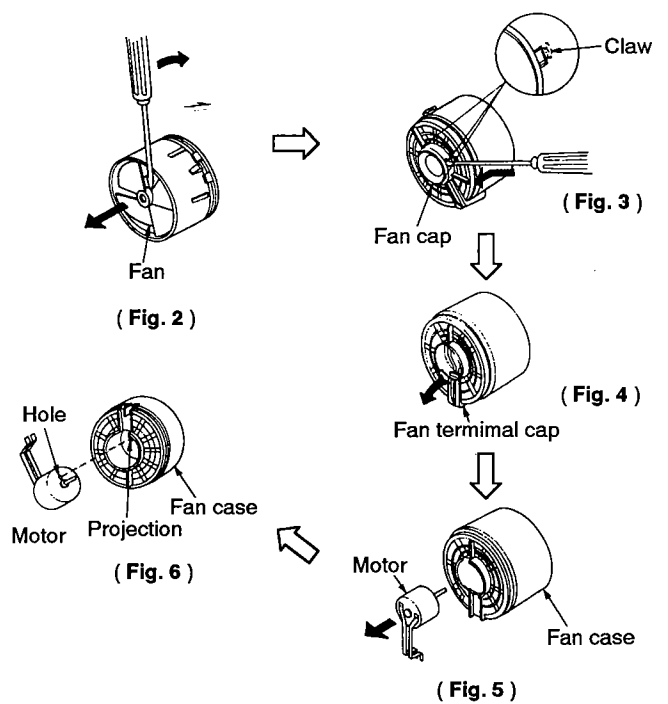

# HOW TO REPLACEMENT THE POWER IC AND REGULATOR TRANSISTOR

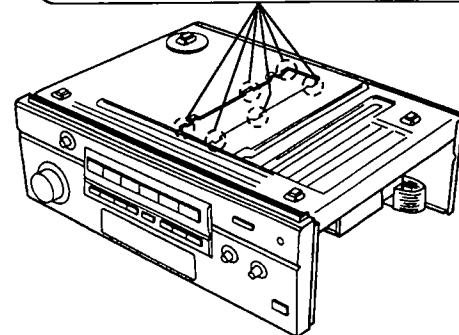
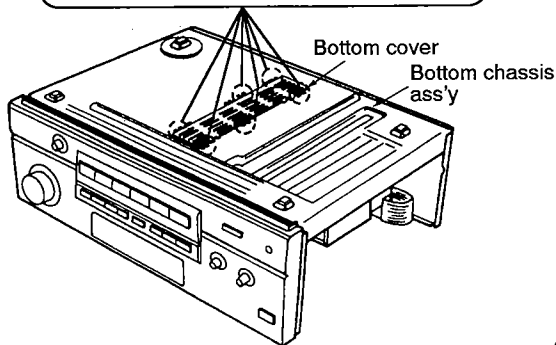
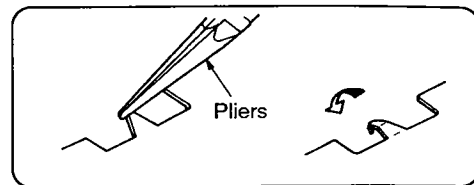
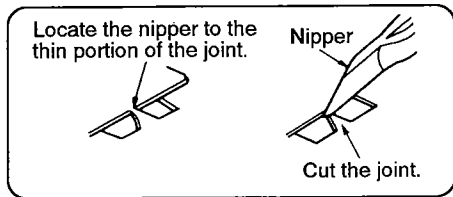

1. Cut the joints(6 portions) between bottom cover and bottom chassis ass'y with nipper.

2. After cutting the joints(6 portions), bend the portions of the bottom chassis ass'y in the direction of arrow with pliers.

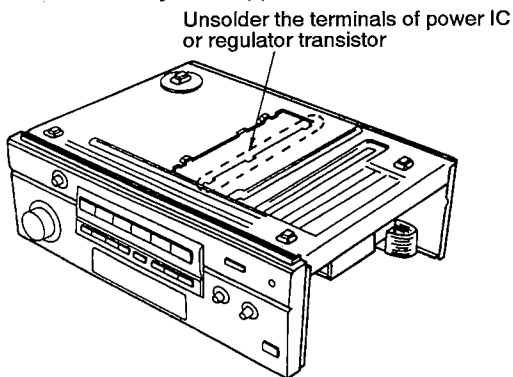

3. When replacing the power IC or regulator transistor, unsolder the terminals of power IC or regulator transistor on the soldered surface.

**CAUTION**

- After replacing the power IC or regulator transistor, apply a sufficient quantity of compound grease (RFKX0002) between the heat sink and the power IC or regulator transistor. (Radiation of power IC & transistor)
- Tighten enough the screws (① ~ ⑥) after replacing the power IC or regulator transistor. Otherwise, the heat radiation works little.

Muting P.C.B.

Claws

- Release the 2 claws of muting P.C.B. and remove it because of using the long screwdriver to tighten the screw firmly.

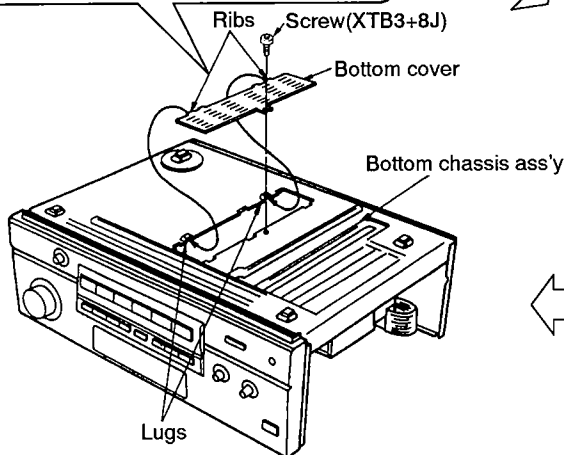
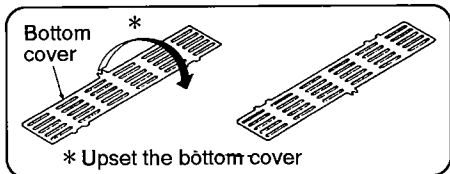

5. After replacing the power IC or regulator transistor, upset the bottom cover and align the ribs of the bottom cover to the lugs on the bottom chassis ass'y.

6. After mounting the bottom cover on the bottom chassis ass'y, fix it with a screw(XTB3+8J).

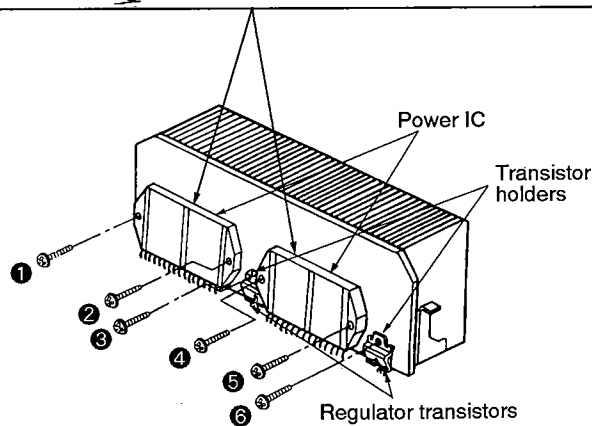

4. Then remove the 6 screws (① ~ ⑥) fixed to the power IC or transistor holders.

## ■ HOW TO CHECK THE MAIN P.C.B.

1. Remove the cabinet according to the disassembly instructions, procedure 1 "Removal of the cabinet" on page 4.
2. Remove the front panel ass'y according to the disassembly instructions, procedure 2 "Removal of the front panel ass'y" on page 4.

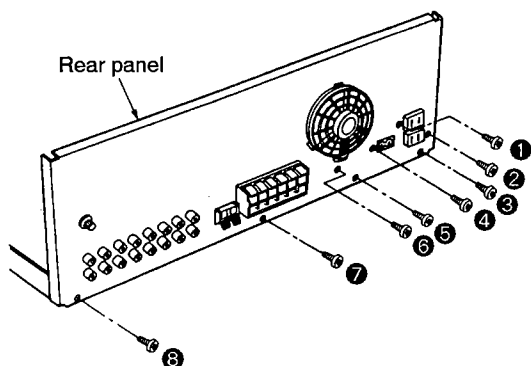

3. Remove the 8 screws (① ~ ⑧).

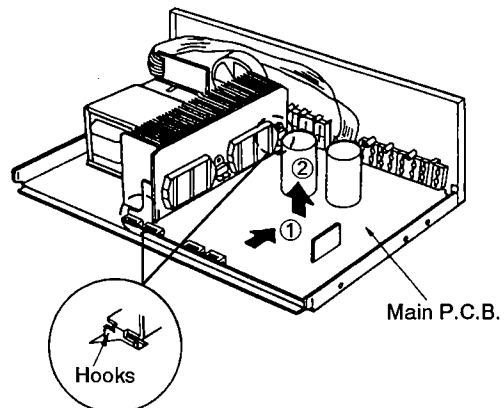

4. Release the 2 hooks by sliding the main P.C.B. in the direction of arrow ①, and then remove the main P.C.B. equipped with rear panel in the direction of arrow ②.

5. Reinstall the front panel ass'y to the main P.C.B.
6. When checking the soldered surface of the main P.C.B. and replacing the parts, do as shown in above.

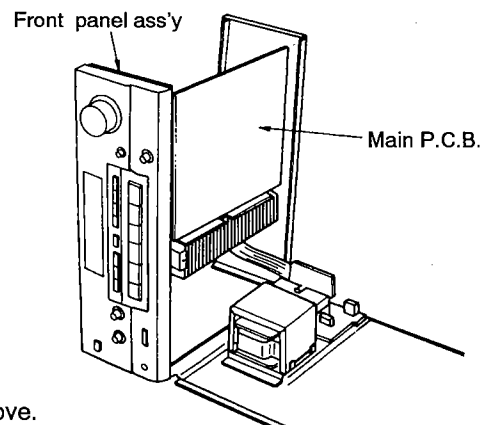



## FAN MOTOR TROUBLESHOOTING GUIDE

The Models SU-G75/G95 employ fan motor error sensing electronics. If the cooling fan is not operation and "OVER LOAD" is displayed on the FL display, check the fan motor and its driving circuit.

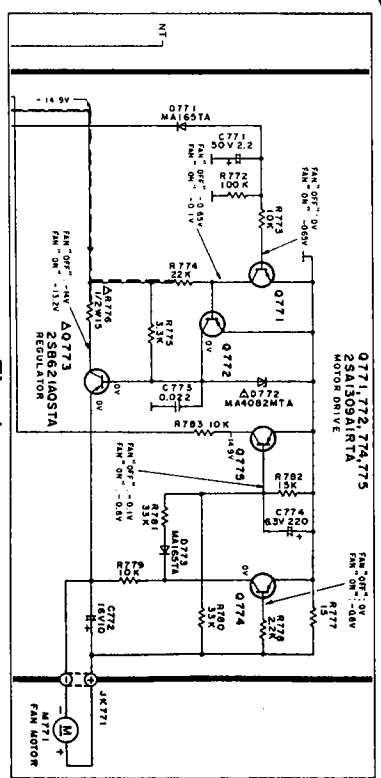
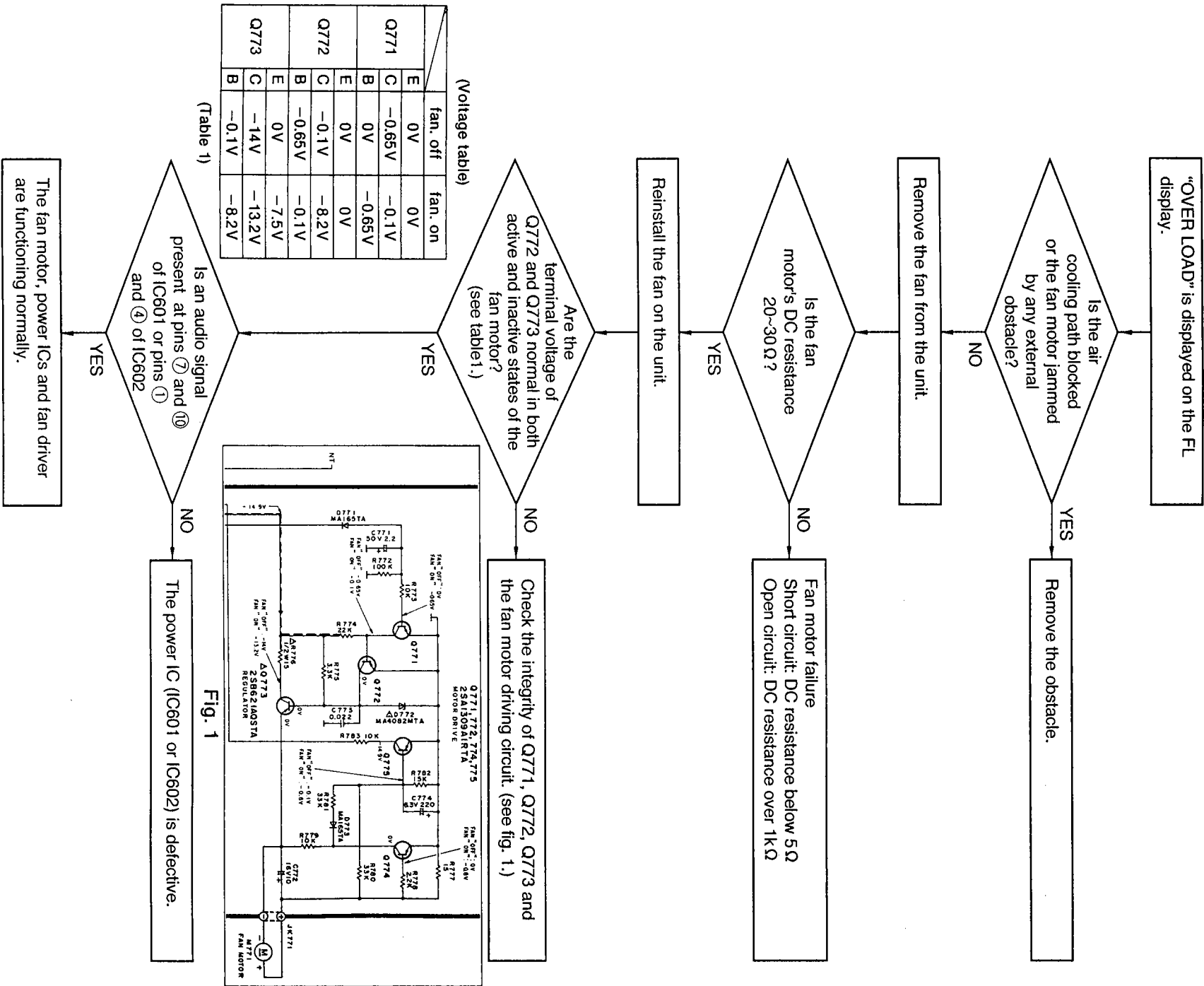

## BLOCK DIAGRAM

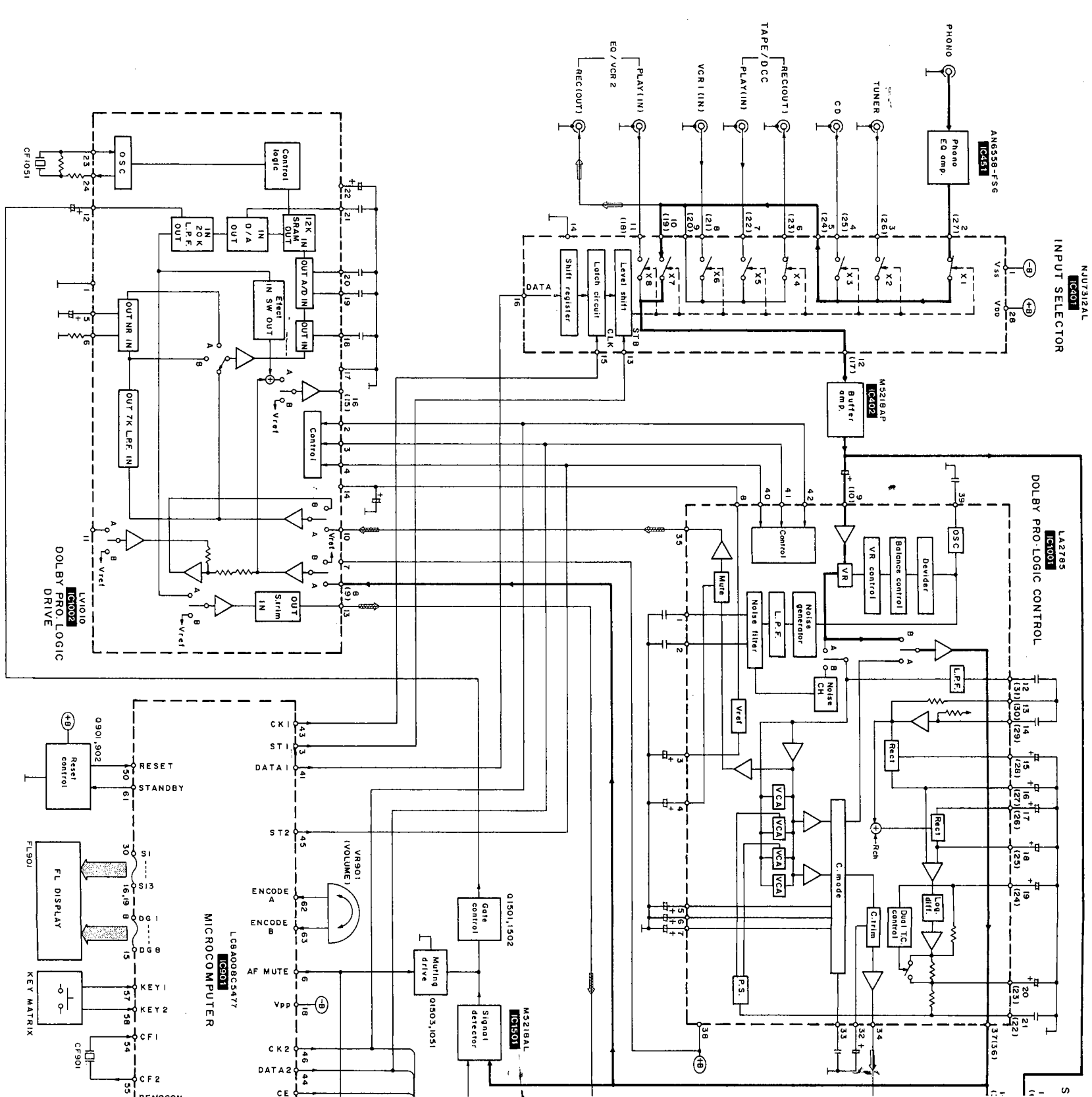

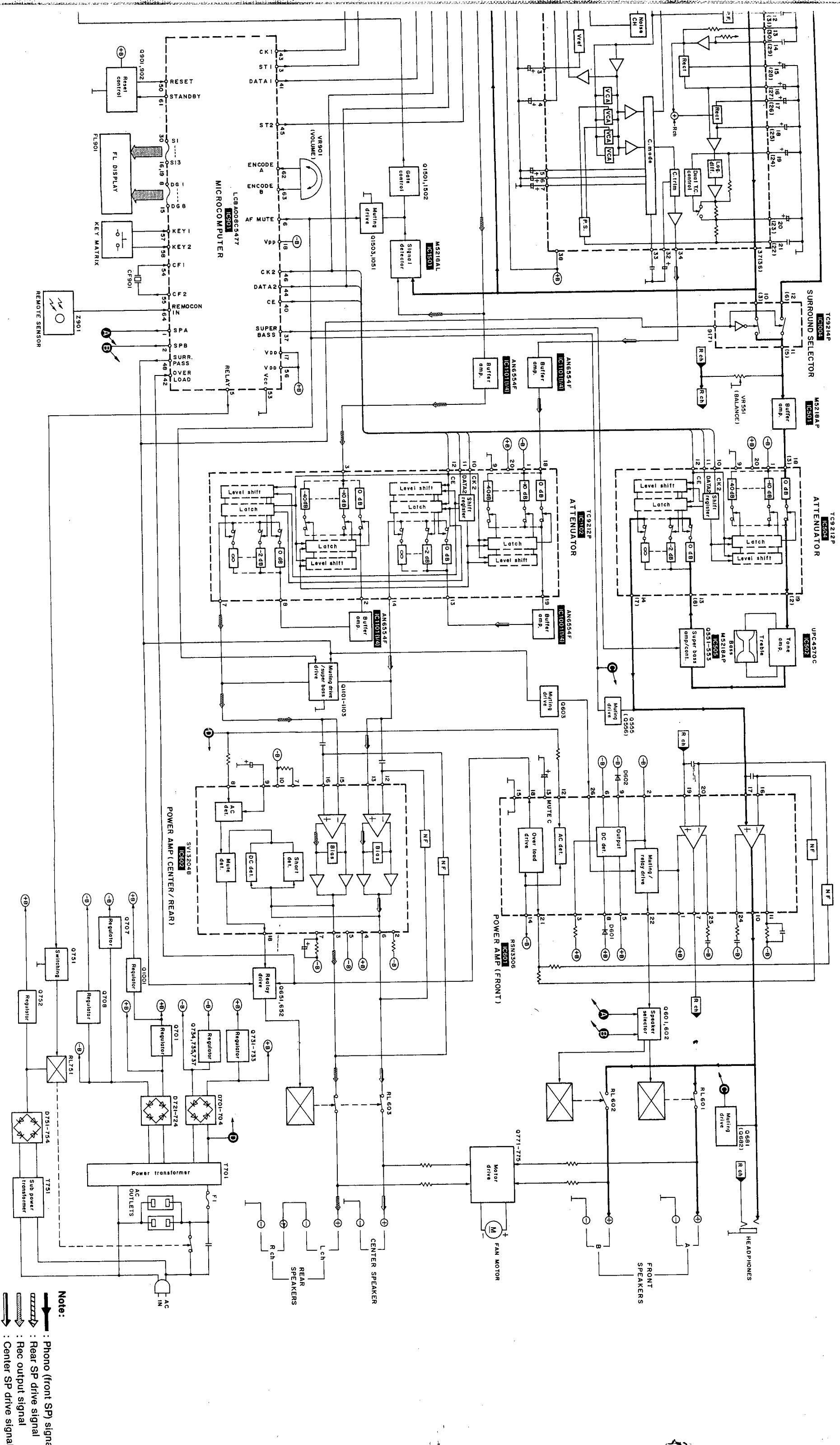

**Note:**

- : Phono (front SP) signal
- : Rear SP drive signal
- : Rec output signal
- : Center SP drive signal

SCHEMATIC DIAGRAM (Parts list on pages 33~37.)

(This schematic diagram may be modified at any time with the development of new technology.)

Note 1:

- S901 : Speaker ON/OFF (SPEAKERS) switch.
- S902~907 : Input select switches.
  - [ S902: VCRI, S903: EQ/VCRI 2, S904: TAPE/DCC, S905: CD, S906: TUNER, S907: PHONO ]
- S908 : Rear level adjust (REAR LEVEL (-)) switch.
- S909 : Center level adjust (CENTER LEVEL (-)) switch.
- S910 : Power "STANDBY" (ON) (POWER, STANDBY (ON) switch.
- S913 : Dolby pro logic surround ON/OFF (SURROUND) switch.
- S914 : Dolby pro logic 3 stereo ON/OFF (3 STEREO) switch.
- S915 : Center mode (CENTER MODE) select switch.
- S916 : Test signal ON/OFF (TEST) switch.
- S917 : Rear level adjust (REAR LEVEL (+)) switch.
- S918 : Center level adjust (CENTER LEVEL (+)) switch.
- S919 : Super bass ON/OFF (SUPER BASS) switch.

Note 2:

**CAUTION: FOR CONTINUED PROTECTION AGAINST FIRE HAZARD, REPLACE ONLY WITH SAME TYPE 6.3A 125V FUSE.**

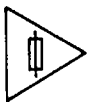

RISK OF FIRE-REPLACE FUSE AS MARKED.

FUSE CAUTION

This symbol located near the fuse indicates that the fuse used is fast operating type. For continued protection against fire hazard, replace with same type fuse. For fuse rating, refer to the marking adjacent to the symbol.

Ce symbole indique que le fusible utilisé est à rapide. Pour une protection permanente, n'utiliser que des fusibles de même type. Ce dernier est indiqué à qu'il le présent symbole est apposé.

Part No.	Original Part No.	Supply Part No.
IC1501	M5218AL	M5218L

- Important safety notice
- Components identified by  $\Delta$  mark have special characteristics important for safety. Furthermore, special parts which have purposes of fire-retardant (resistors), high-quality sound (capacitors), low-noise (resistors), etc. are used as occasion calls. When replacing any of components, be sure to use only manufacturer's specified parts shown in the parts list.
- The supply parts number is described alone in the replacement parts.

Caution!

- IC and LSI are sensitive to static electricity. Secondary trouble can be prevented by taking care during repair.
- Cover the parts boxes made of plastics with aluminum foil.
- Ground the soldering iron.
- Put a conductive mat on the work table.
- Do not touch the legs of IC or LSI with the fingers directly.

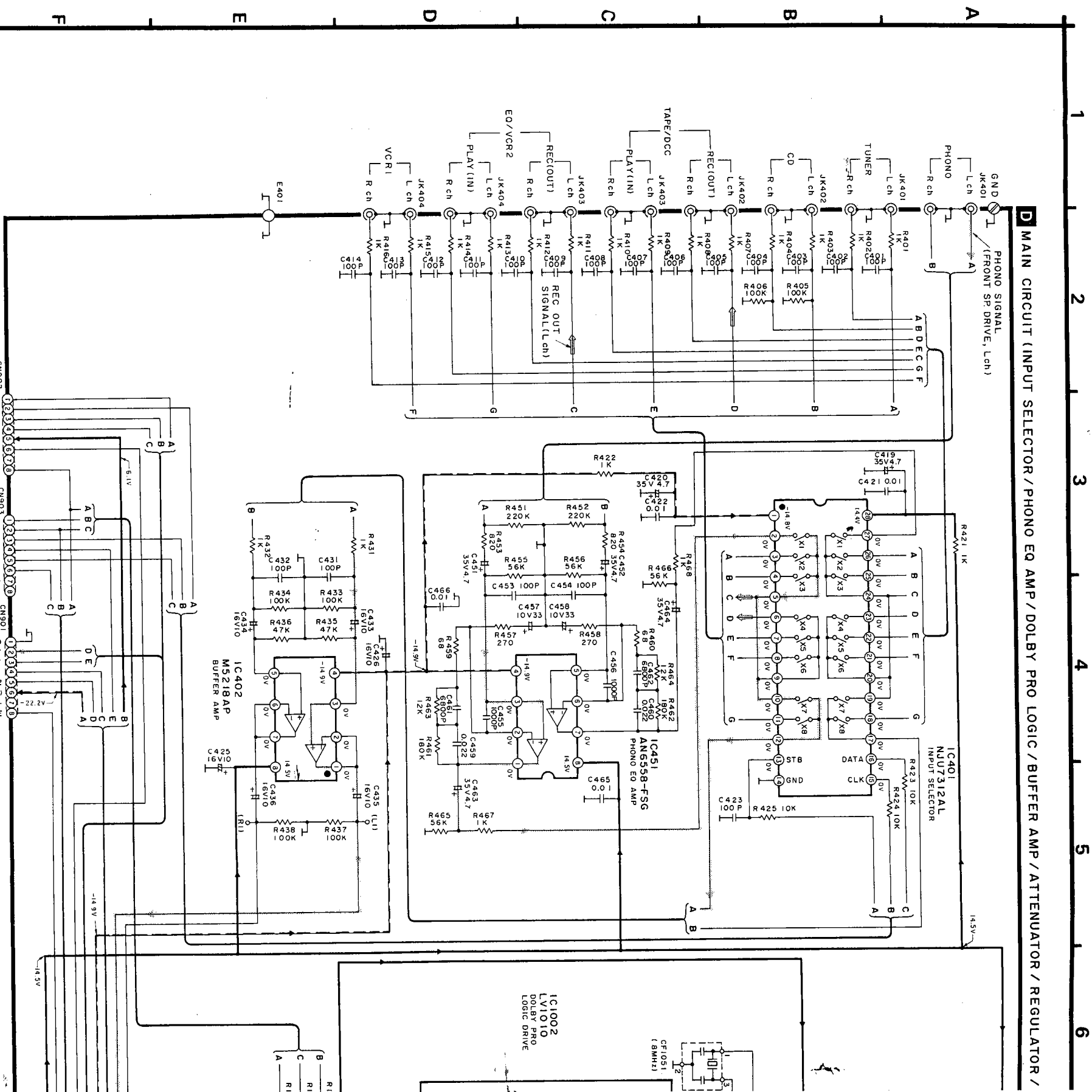

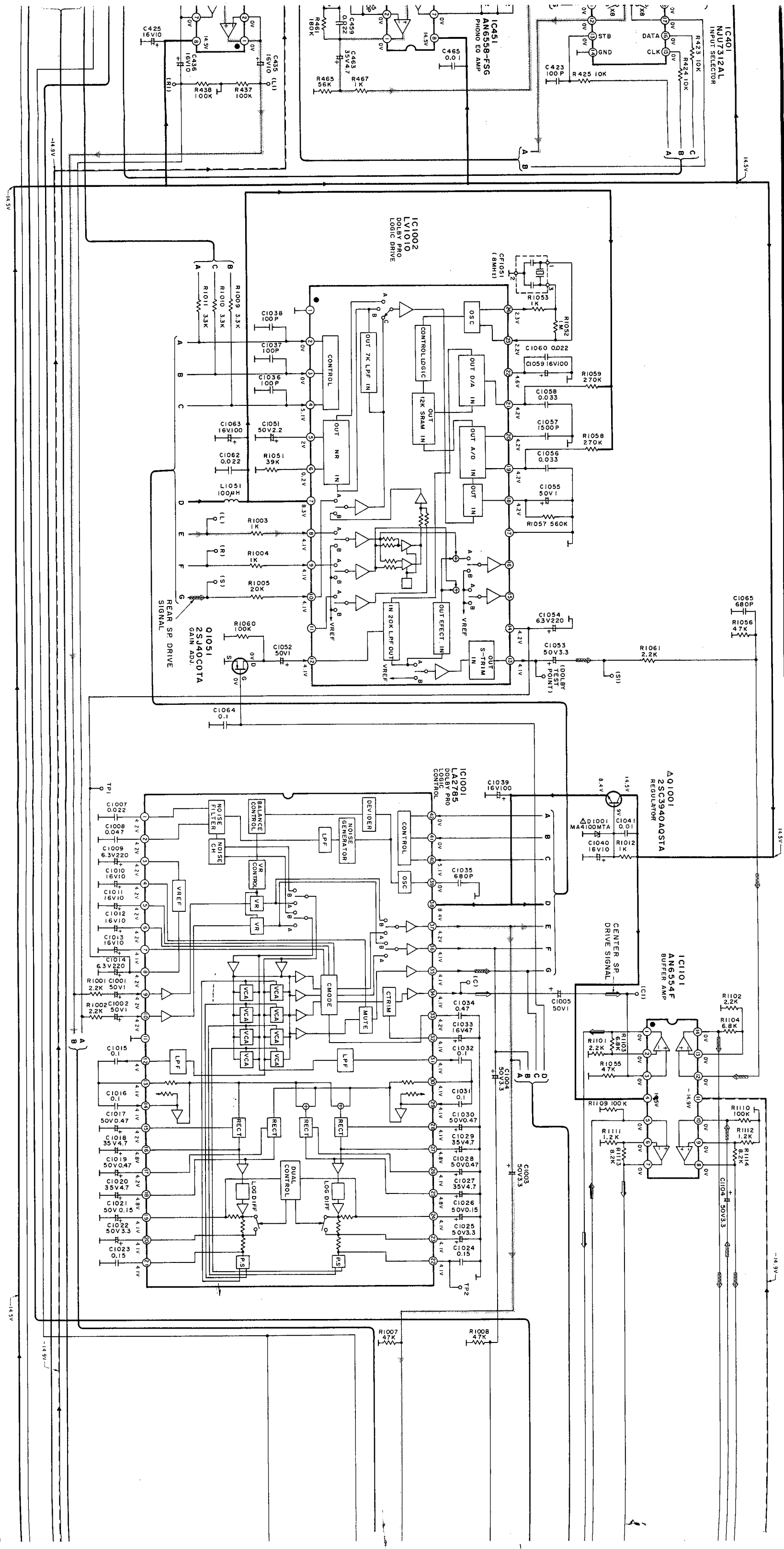

MUTING CIRCUIT

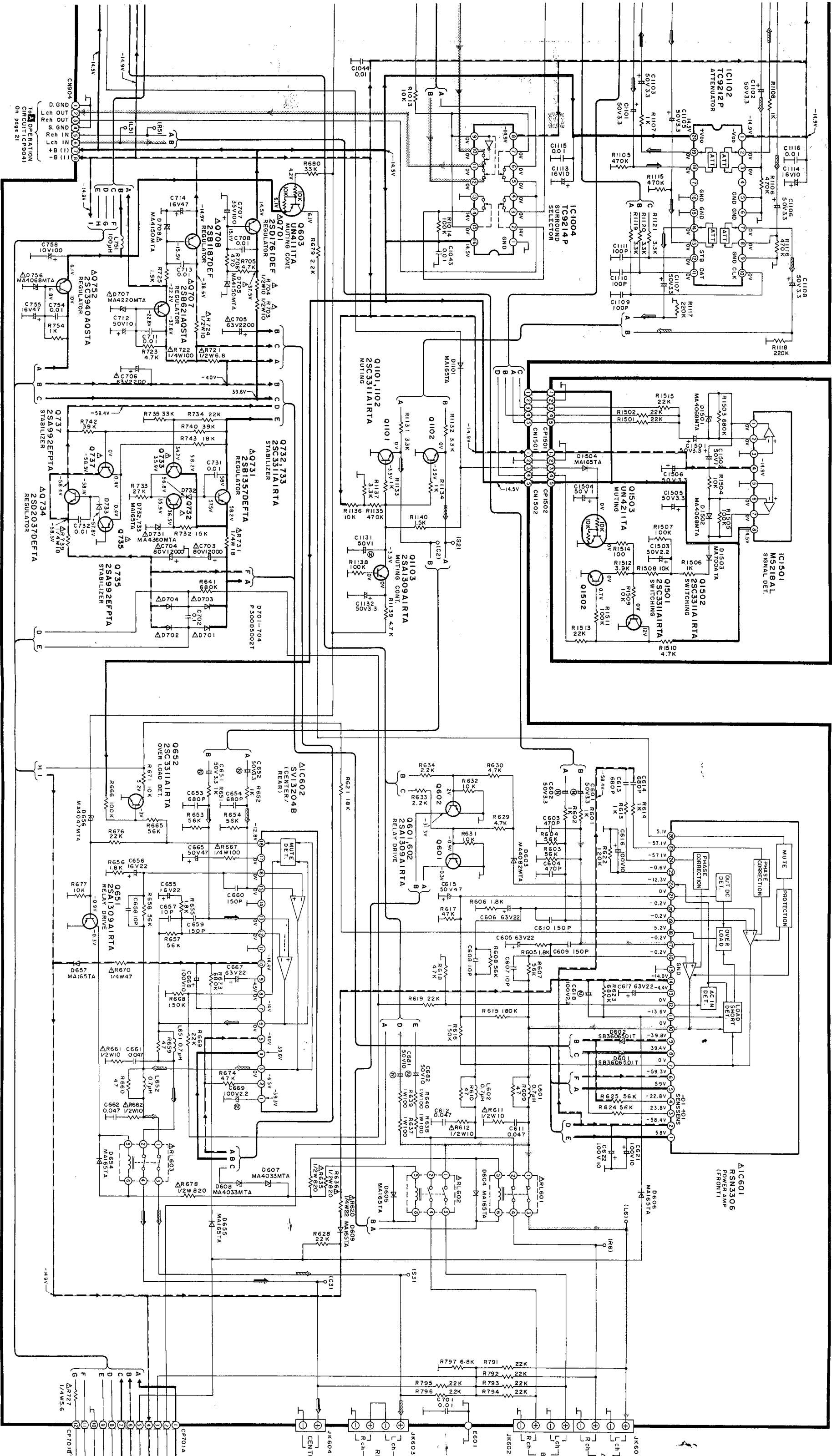

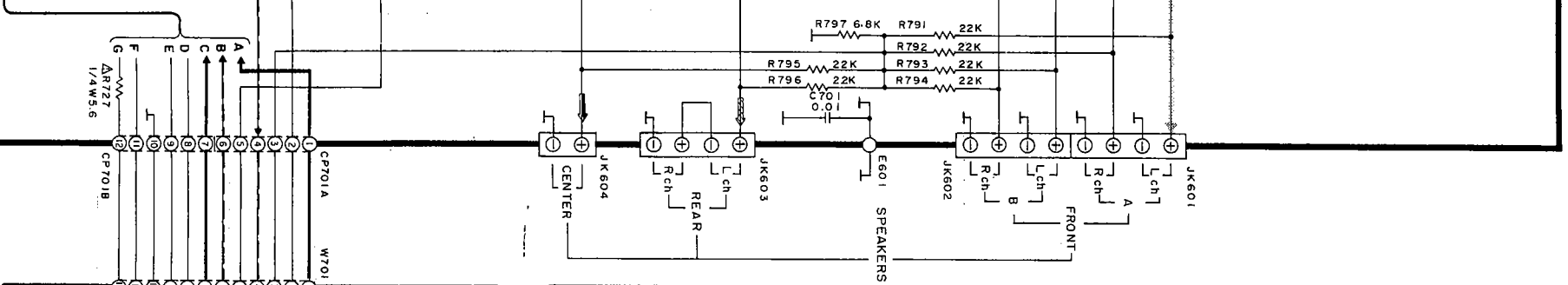
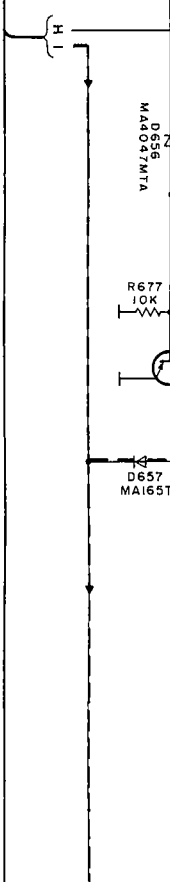
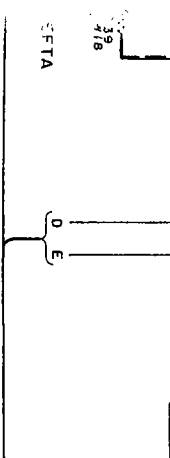
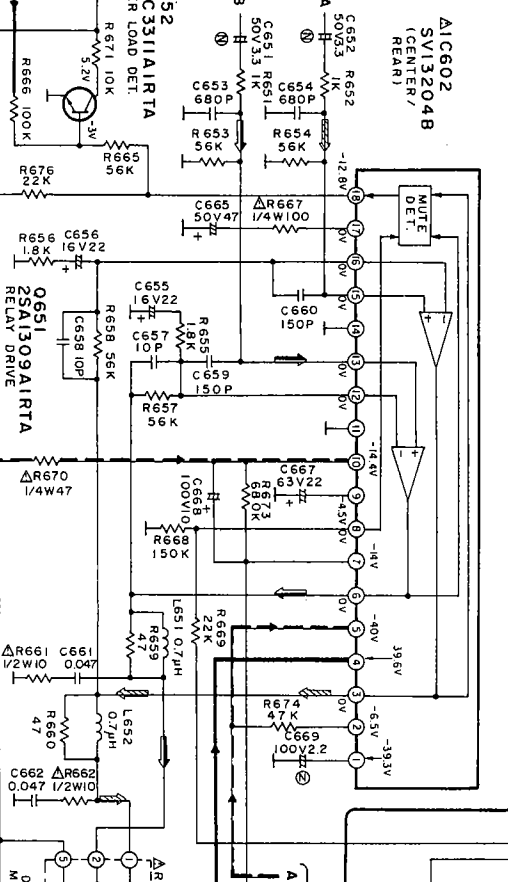
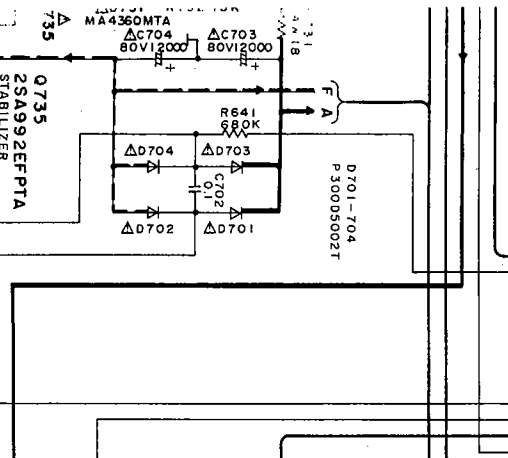
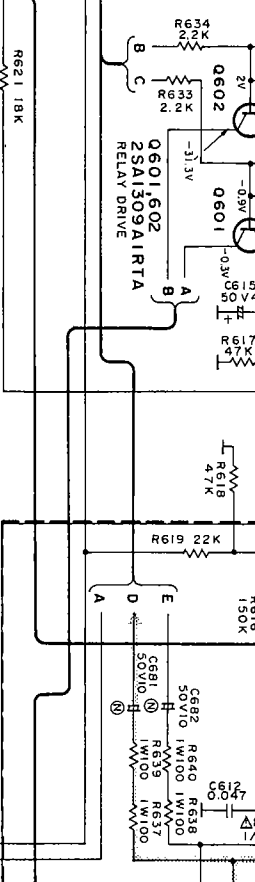
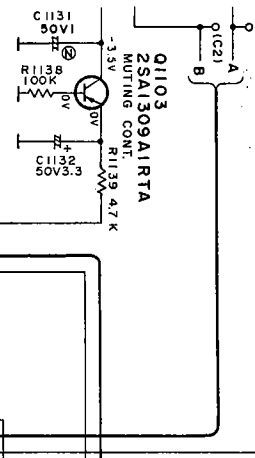
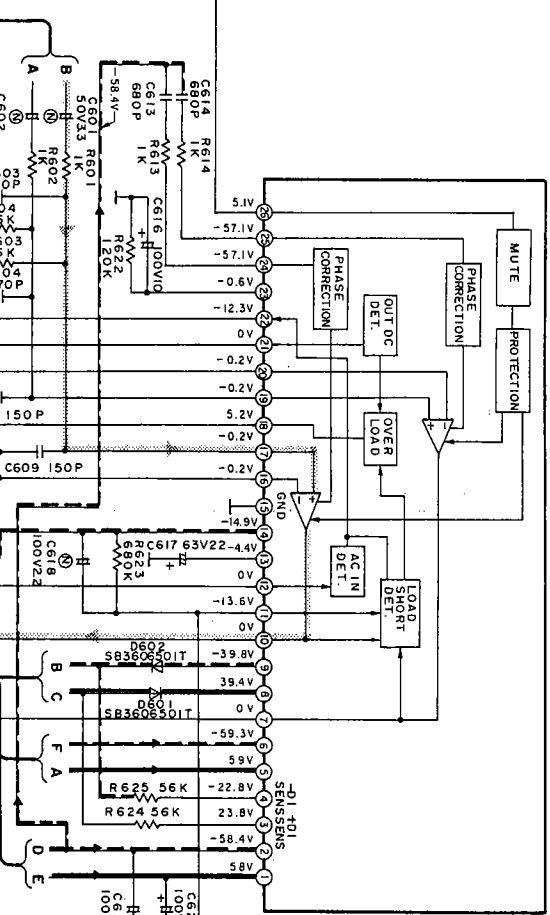
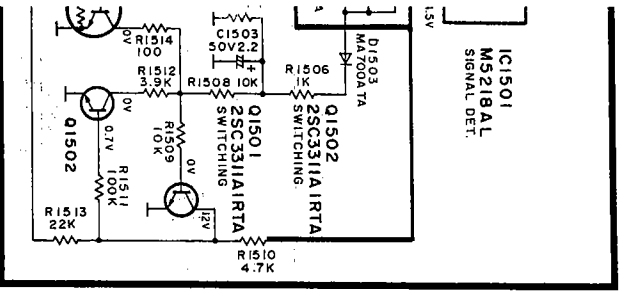

**F** POWER SUPPLY CIRCUIT

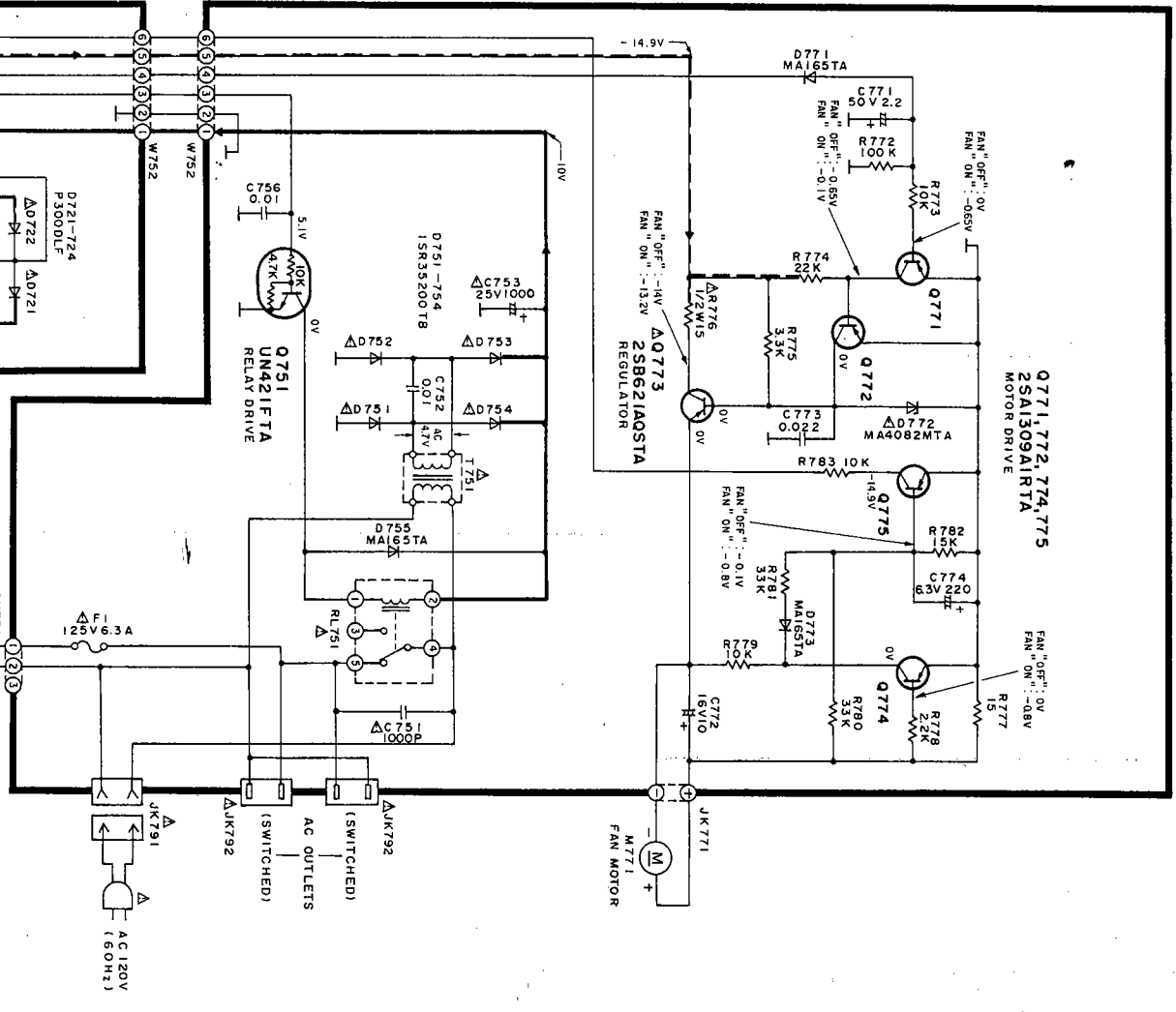

**G** POWER TRANSFORMER CIRCUIT

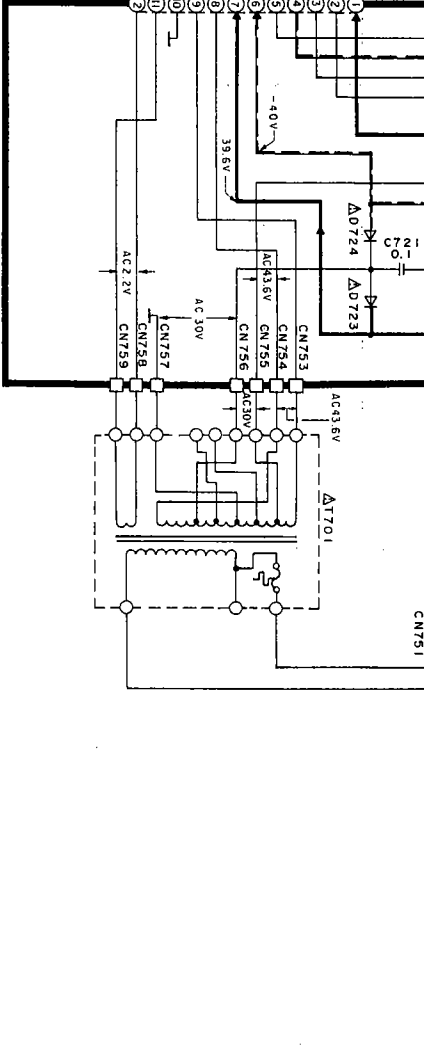

WIRING CONN

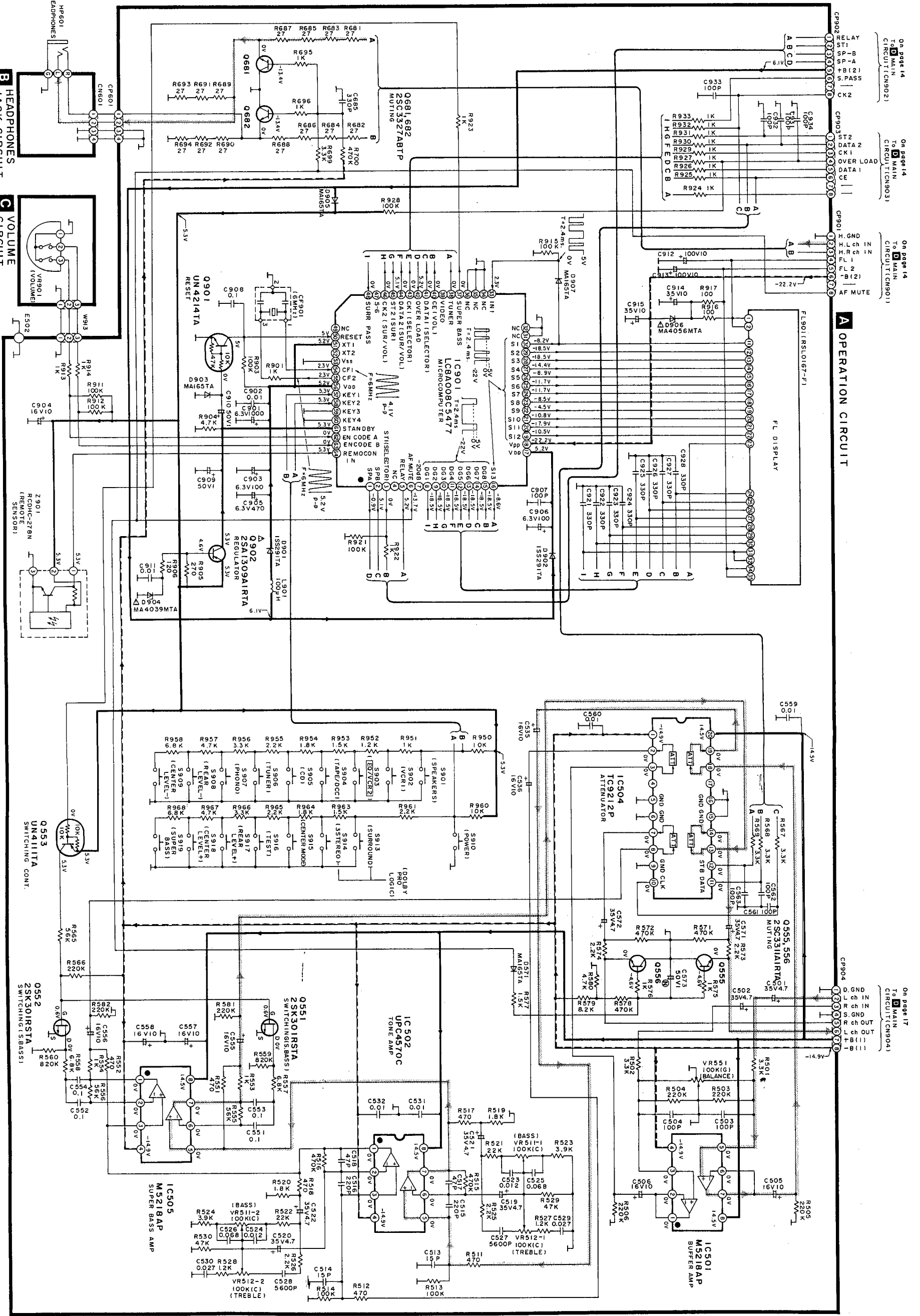

On page 14  
To MAIN CIRCUIT (CN902)

On page 14  
To MAIN CIRCUIT (CN903)

On page 14  
To MAIN CIRCUIT (CN901)

On page 17  
To MAIN CIRCUIT (CN904)

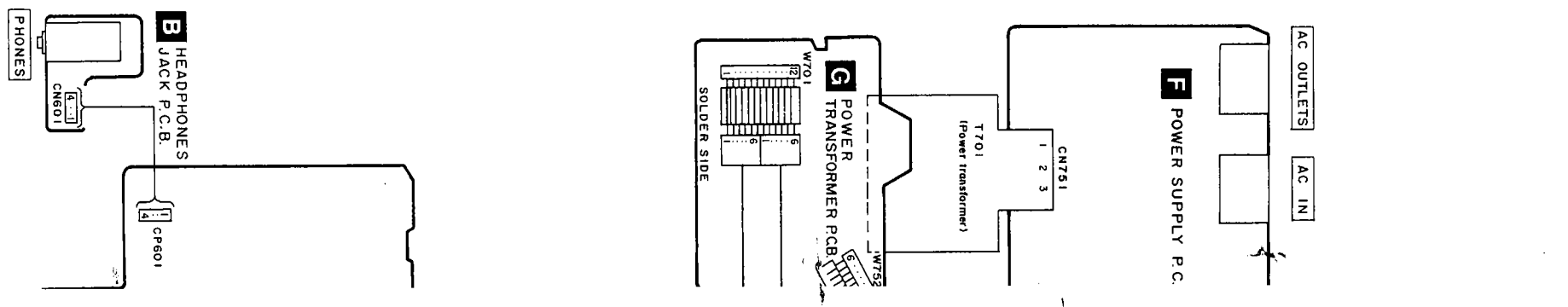

WIRING CONNECTION DIAGRAM

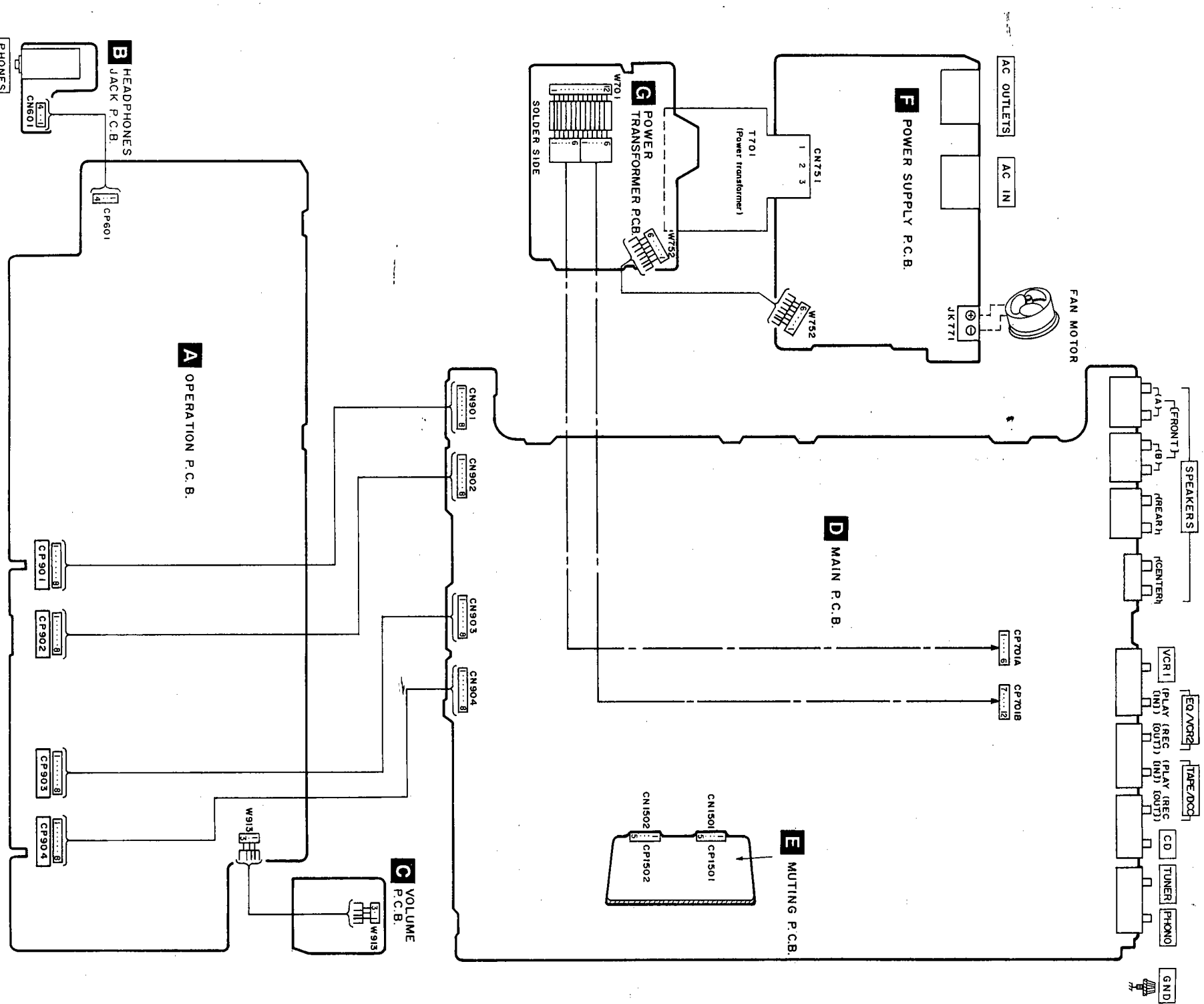
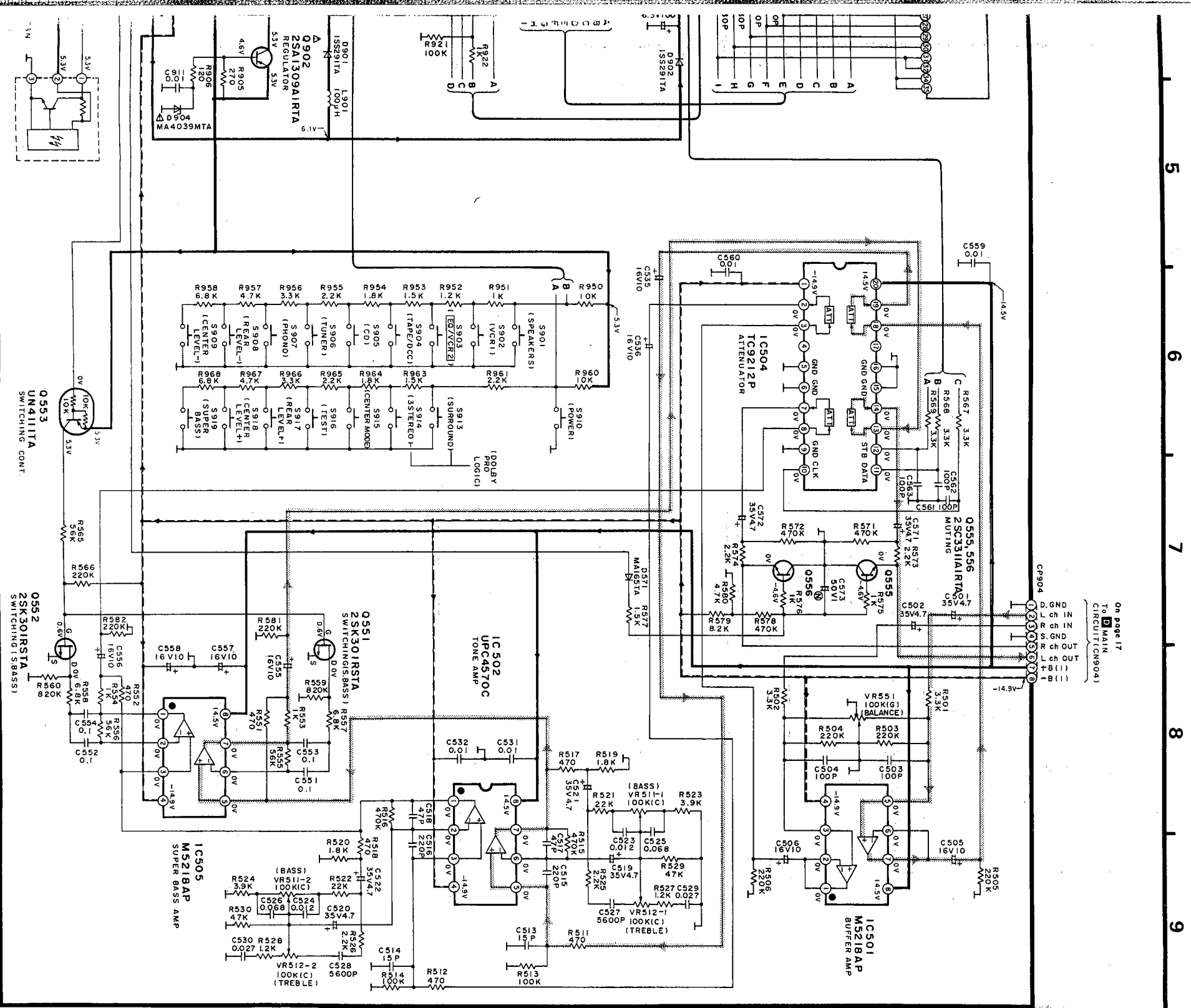



# PRINTED CIRCUIT BOARDS

**G** POWER TRANSFORMER P.C.B. (REP1741A-P)

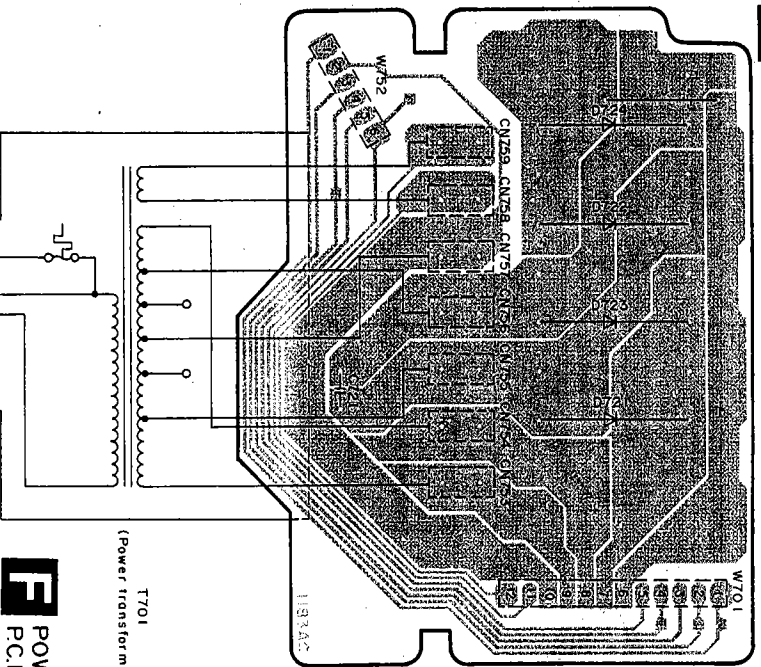

**F** POWER SUPPLY P.C.B. (REP1741A-P)

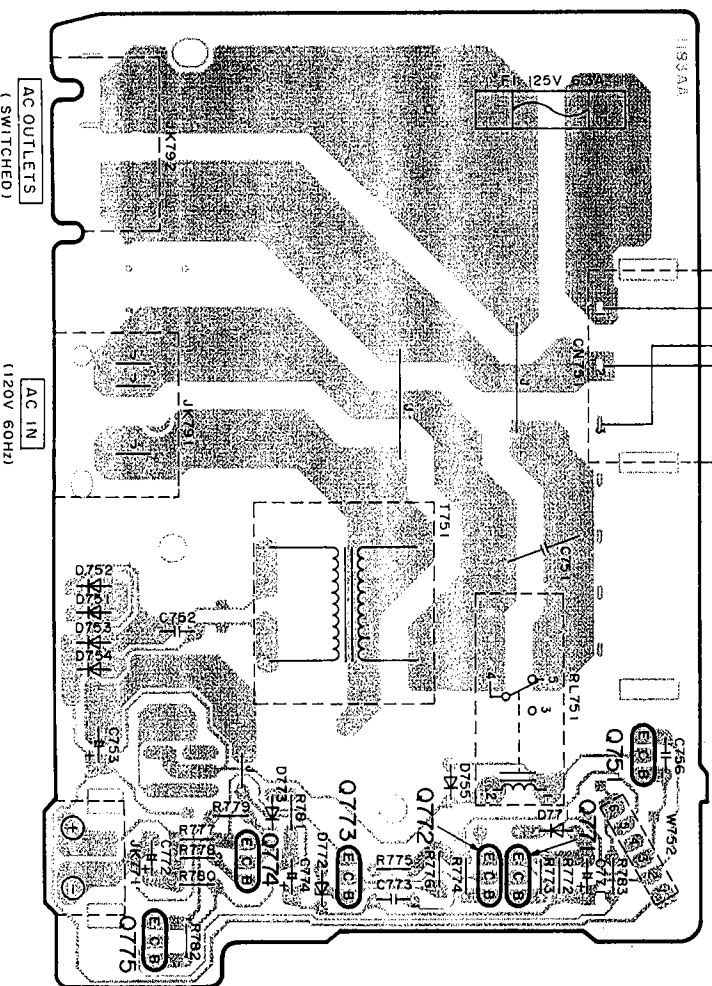

**D** MAIN P.C.B. (REP1739B-M)

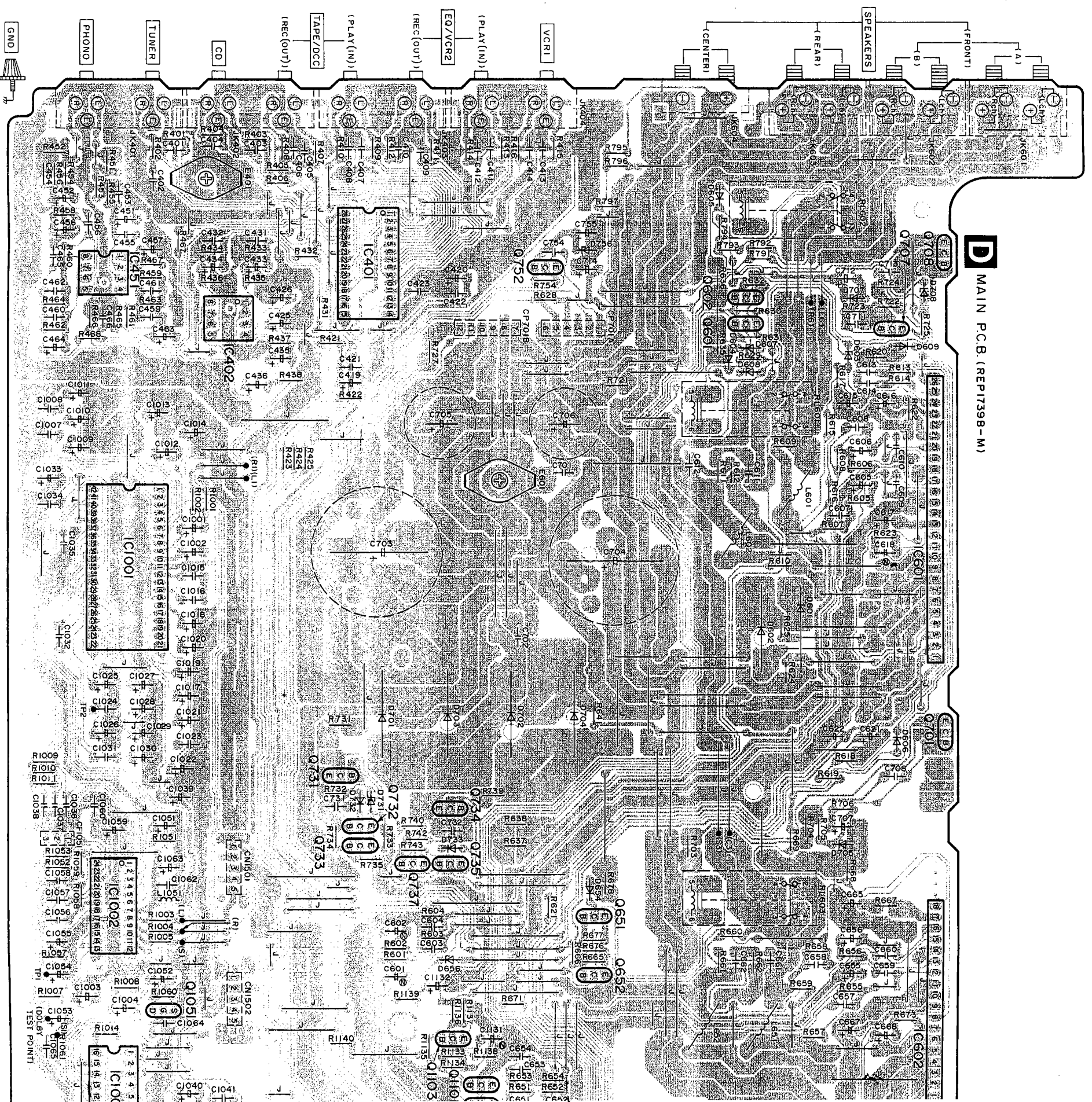



5 6 7 8 9 10 11 12 13 14

**D** MAIN P.C.B. (REP17398-M)

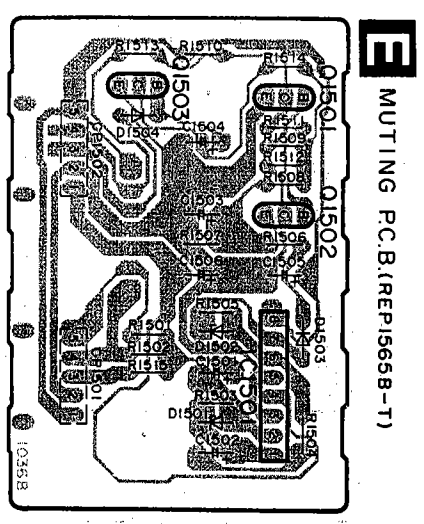
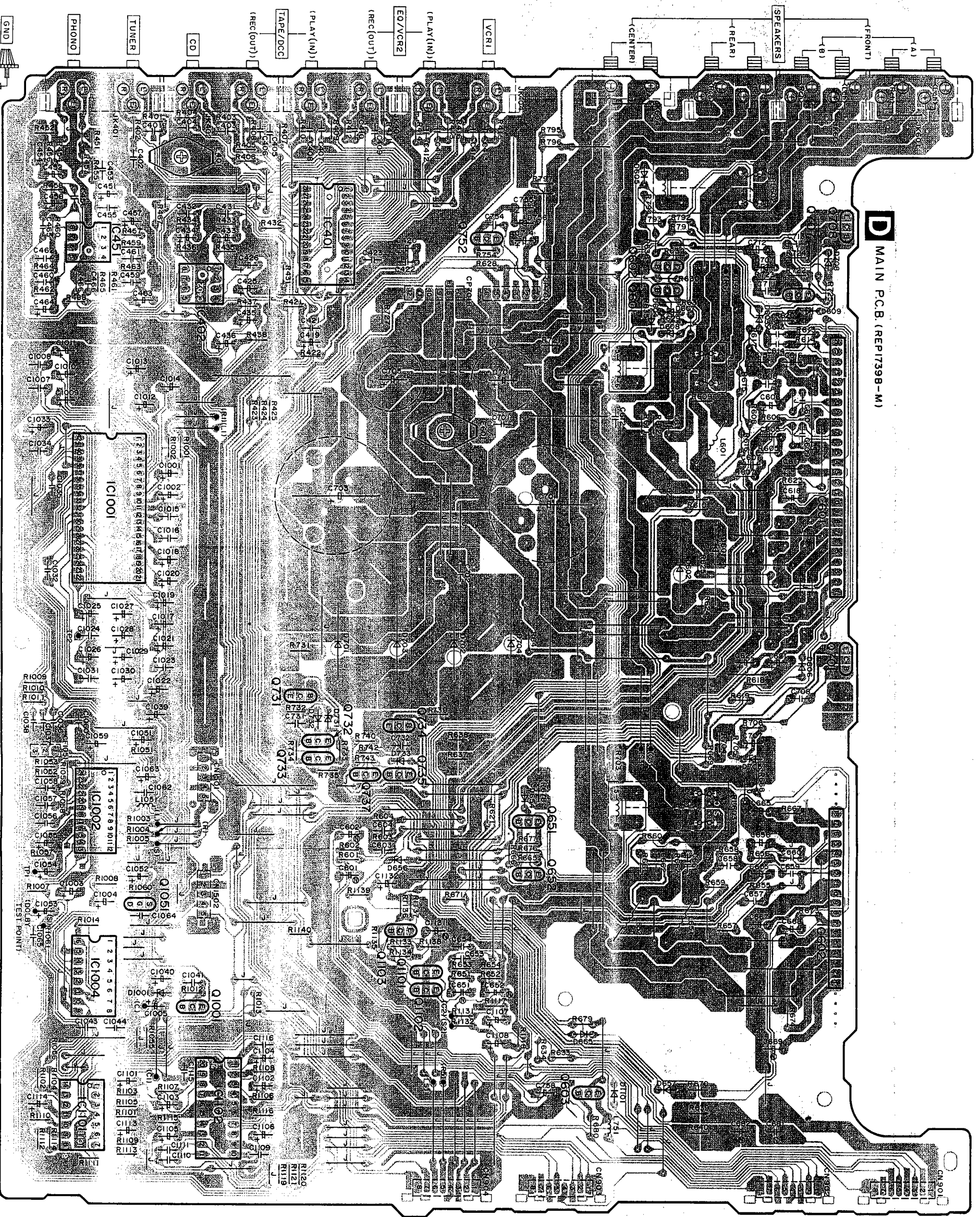

**E** MUTING P.C.B. (REP15658-T)

**A** OPERATION P.C.B. (REP1740B-S)

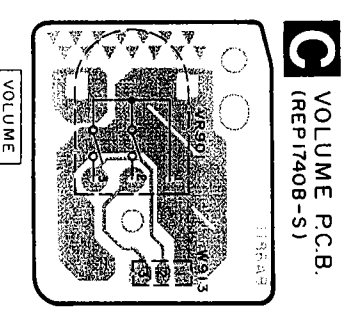
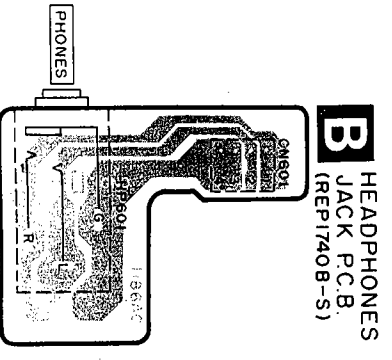
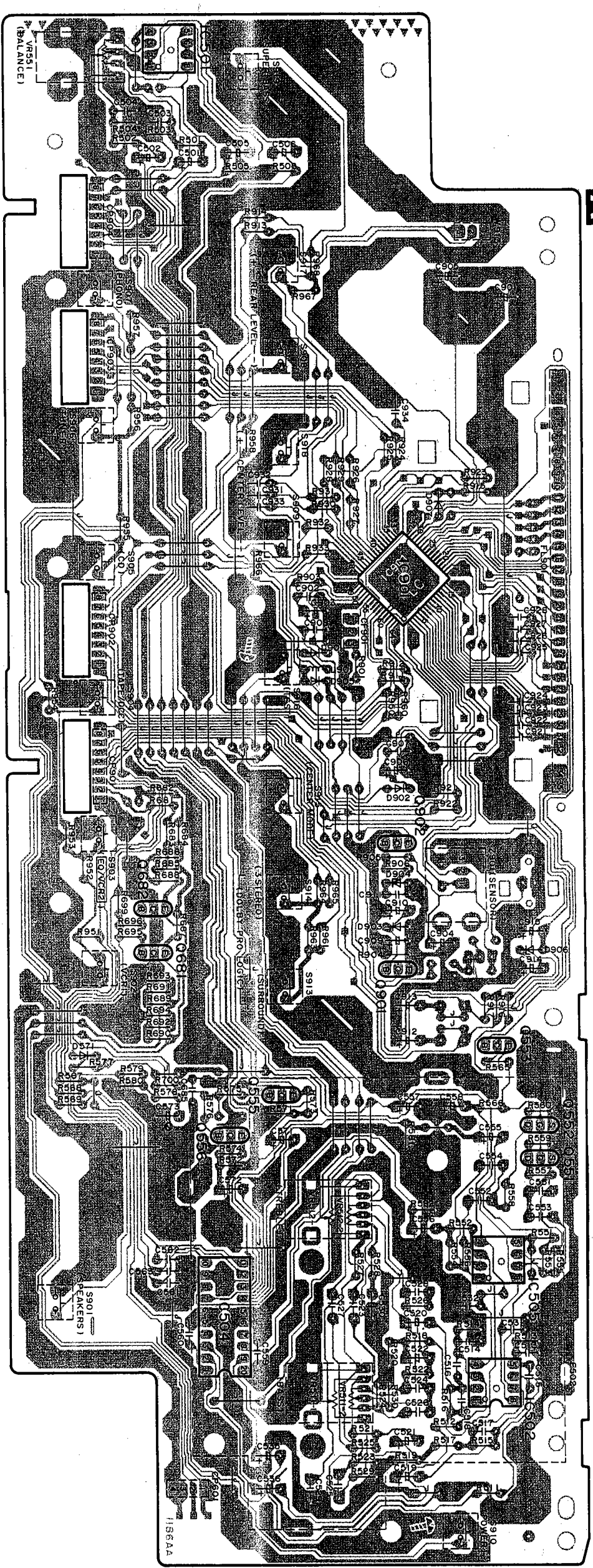







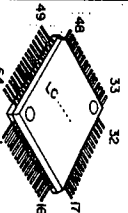
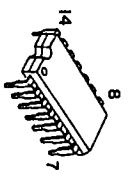
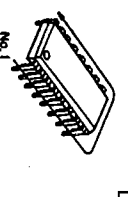
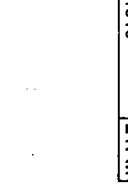
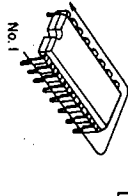
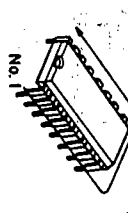

**TERMINAL GUI**

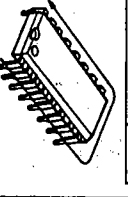
<p>LC8A00805477</p>	<p>AN6558-FS LA2785</p>
<p>2SA992EFTA 2SB621AQSTA</p>	<p>2SC394</p>
<p>2SB1357DEFTA 2SD2037DEFTA</p>	<p>2SJA4</p>
<p>Ca Cathode Anode</p>	<p>MA4033M MA4039M MA4047M MA4056M MA4068M MA4082M</p>

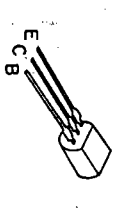
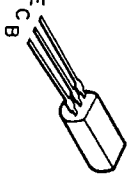
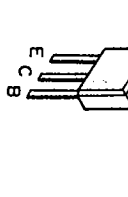
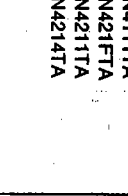
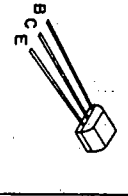
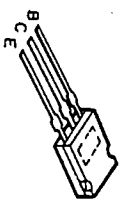
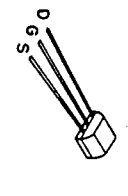
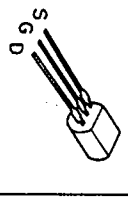
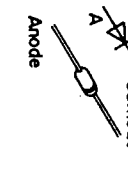

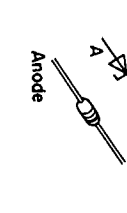
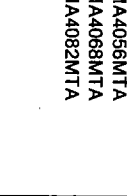
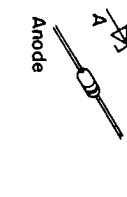
■ TERMINAL GUIDE OF IC'S, TRANSISTORS AND DIODES

 <p>LC8A00805477</p>	 <p>AN6554F</p>	 <p>M5218AP LV1010</p>	 <p>M5218AL</p>	 <p>TC9214P TC9212P</p>
 <p>AN6558-FSG LA2785</p>	 <p>IJC4570C NJU7312AL</p>	 <p>SV13204B</p>	 <p>RSN3306</p>	 <p>M5218AL</p>
 <p>2SA992EFPTA 2SB821AOSTA</p>	 <p>2SC3940AOSTA</p>	 <p>2SA1309AIRTA 2SC3311AIRTA UN4111TA UN421FTA UN4211TA UN4214TA</p>	 <p>2SC3327ABTP</p>	 <p>2SB1187DEF 2SD1761DEF</p>
 <p>2SB1357DEFTA 2SD2037DEFTA</p>	 <p>2SJ400DTA</p>	 <p>2SK301RSTA</p>	 <p>MA165TA MA700ATA ISS291TA 1SR35200TB</p>	 <p>P300DLF P300D5002T SB3906501T</p>
 <p>Cd Cathode Anode</p>	 <p>Cd Cathode Anode</p>	 <p>Cd Cathode Anode</p>	 <p>Cd Cathode Anode</p>	 <p>Cd Cathode Anode</p>

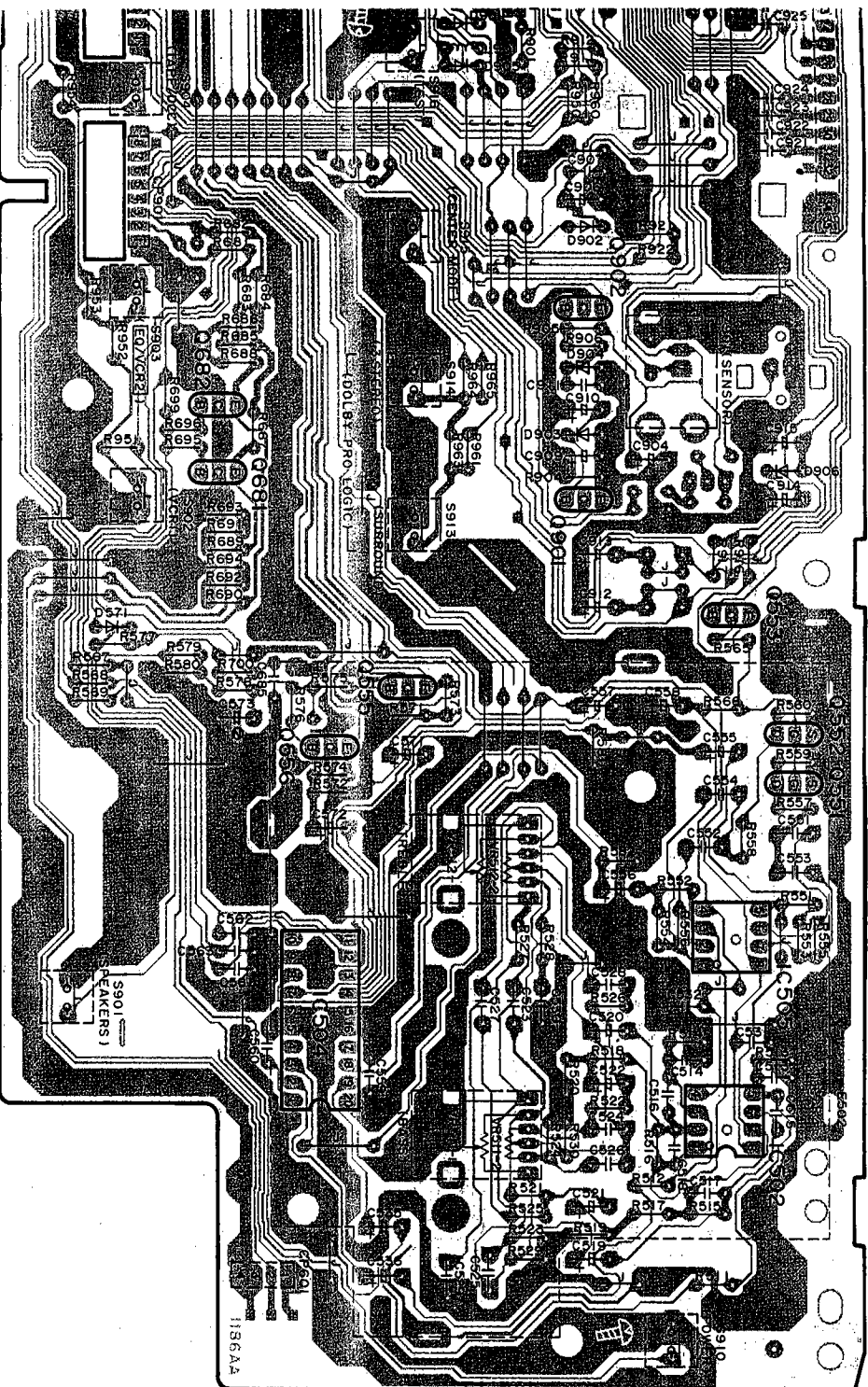

**C** VOLUME P.C.B.  
(REP1740B-S)

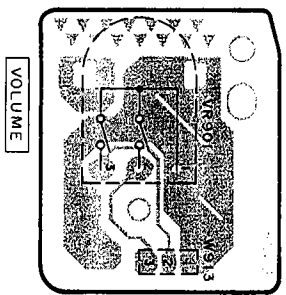

# ■ TERMINAL FUNCTION OF IC

## • IC901 (LC8A008C5477): Microcomputer

Pin No.	Mark	I/O Division	Function
1 • 2	SPA • SPB	O	Speaker select control terminal
3	ST1	O	Level shift control terminal
4	NC	—	Not used, open
5	RELAY	O	Relay control terminal
6	AF MUTE	O	Muting control terminal
7	-20dB	O	Muting control (-20dB) terminal
8 } 15	DG1 } DG8	O	Digit signal of FL display
16	S13	O	Segment signal of FL display
17	VDD	I	Power supply terminal
18	VPP	I	Power supply terminal of FL display
19 } 30	S12 } S1	O	Segment signal of FL display
31 • 32	NC	O	No connection
33	INI	—	Not used, connected to resistor
34	NC	I	No connection
35	NC	I	No connection
36	NC	I	No connection
37	SUPER BASS	—	Super bass control terminal
38	TUNER	O	Not used, open
39	VIDEO	O	Not used, open
40	CE	O	Chip enable terminal

Pin No.	Mark	I/O Division	Function
41	DATA1	O	Serial data signal
42	OVER LOAD	I	Over load detect terminal
43	CK1	O	Serial clock signal
44	DATA2	O	Serial data signal
45	ST2	O	Level shift control terminal
46	CK2	O	Serial clock signal
47	5-6	O	Remote control terminal
48	SURR BASS	O	Surround selector terminal
49	NC	—	No connection
50	RESET	I	Reset detect terminal
51	XT1	—	Not used, connected to power supply
52	XT2	—	Not used, open
53	VSS	—	GND terminal
54	CF1	I	Crystal oscillator
55	CF2	O	Terminal (6MHz)
56	VDD	I	Power supply terminal
57 } 60	KEY1 } KEY4	I	Key matrix detect terminal
61	STANDBY	O	Power detect terminal
62 • 63	ENCODE A • ENCODE B	—	Not used, connected to power supply
64	REMOCON IN	I	Remote control terminal

# REPLACEMENT PARTS LIST

**Notes:** \*Important safety notice:  
 Components identified by  $\Delta$  mark have special characteristics important for safety.  
 Furthermore, special parts which have purposes of fire-retardant (resistors), high-quality sound (capacitors), low-noise (resistors), etc. are used.  
 When replacing any of components, be sure to use only manufacturer's specified parts shown in the parts list.  
 \*The "(SF)" mark denotes the standard part.

Ref. No.	Part No.	Part Name & Description	Remarks
		CABINET AND CHASSIS	
1	RGW0197-K	BASS/TREBLE/BALANCE KNOB	
2	RGW0199-K	VOLUME KNOB	
3	RHD30035-K	SCREW	
4	RKMO041A-K	CABINET	
5	XTBS3+8JFZ1	SCREW	
6	RGR0186B-A	REAR PANEL	
7	RMCO158	TRANSISTOR HOLDER	
8	RFKJUG75PP-K	BOTTOM CHASSIS ASS'Y	
8-1	SKL293	RUBBER FOOT	
9	RMNO217-1	P. C. B. HOLDER	
10	SNE4021-1	NUT	
11	REZO645	FLAT CABLE (W913) (3P)	
12	RMNO195	FL HOLDER PIECE	
13	SHE187-2	P. C. B. SUPPORT	
14	RFKEUG75PP-K	CONNECTOR ASS'Y (W701) (12P)	
15	RWJ1806110KK	FLAT CABLE (W752) (6P)	
16	RMNO260	FL HOLDER	
17	XTB3+20JFZ	SCREW	
18	XTB3+8JFZ	SCREW	
19	XTW3+15T	SCREW	
20	REMO020-1	FAN UNIT	
20-1	MDN-4RB4MRC	MOTOR	
20-2	SHE232-1	FAN	
20-3	RMQ0209-K	FAN CASE	
20-4	RMQ0208-K	FAN CAP	
20-5	SUS271	SPRING	
20-6	RMQ0212-K	FAN TERMINAL CAP	
21	RFKUG95PP-K	FRONT PANEL ASS'Y	
21-1	RKWO327-K	TRANSPARENT PLATE	
22	RGU0882-K	POWER BUTTON	
23	RGU1027-K	SELECTOR/PRO. LOGIC BUTTON	
24	RHD26016	SCREW	
25	RFKNUG75PPAK	SPEAKERS BUTTON ASS'Y	
26	RFKNUG75PPBK	SUPER BASS BUTTON ASS'Y	
27	XTBS26+8J	SCREW	
28	SNE2123	GND TERMINAL	
29	RSCO105-2	SHIELD PLATE	
		PACKING MATERIAL	
P1	RPG1948	PACKING CASE	
P2	RPNO682-2	CUSHION	
P3	XZB60X65A01Z	PROTECTION BAG	

Ref. No.	Part No.	Part Name & Description	Remarks
		ACCESSORIES	
A1 *	RFKSHWA22P-K	INSTRUCTION MANUAL ASS'Y	SC-S3500/S3550 for U. S. A.
A1 *	RFKSHWA32P-K	INSTRUCTION MANUAL ASS'Y	SC-S4500/S4505/S4550 for U. S. A.
A1 *	RFKSHWA42PCK	INSTRUCTION MANUAL ASS'Y	SC-S2500/S2550 for CANADA.
A1 *	RFKSHWA62PCK	INSTRUCTION MANUAL ASS'Y	SC-S3500/S3550 for CANADA.
A2 *	RQAO085	WARRANTY CARD	for U. S. A.
A2 *	SQX7183	WARRANTY CARD	for CANADA.
A3 *	RQCB0391	SERVICENTER LIST	for U. S. A.
A3 *	SQX9131	SERVICENTER LIST	for CANADA.
A4 *	RAK-SA112MH	REMOTE CONTROL TRANSMITTER	SC-S2500/S2550 for CANADA.
A4 *	RAK-SA723MH	REMOTE CONTROL TRANSMITTER	SC-S3500/S3550/S4500/ S4505/S4550 for U. S. A.
			SC-S3500/S3550 for CANADA.
A4-1 *	RKK0057-K	BATTERY COVER	SC-S2500/S2550 for CANADA.
A4-1 *	RKK0020-K	BATTERY COVER	SC-S3500/S3550/S4500/ S4505/S4550 for U. S. A.
			SC-S3500/S3550 for CANADA.
A5 *	RSA0006	FM INDOOR ANTENNA	for TUNER
A6 *	RSA0010	AM LOOP ANTENNA SET	for TUNER
A6-1 *	RMNO244	AM ANTENNA HOLDER	for TUNER
A6-2 *	XTN3+10AFZ	SCREW	for TUNER
A7 *	SJA172	AC POWER SUPPLY CORD	$\Delta$ (SF)
A8 *	SJPK2203-2	STEREO CONNECTION CABLE	(40cm)
A9 *	SJP2249-3	STEREO CONNECTION CABLE	(80cm)

**Note:** • Parts identified by the "\*" mark are contained in the carton (accessories box) of SH-WA22 (P), SH-WA32 (P), SH-WA52 (PC) or SH-WA62 (PC) listed in the table "LINE-UP OF COMPONENTS" on the page 3.  
 Refer to the packaging on page 3, 4 of the Technical Information for Model No. SH-WA12/SH-WA22/SH-WA32/SH-WA42/SH-WA52/SH-WA62, Order No. AD9401009T1.

CABINET PARTS LOCATION

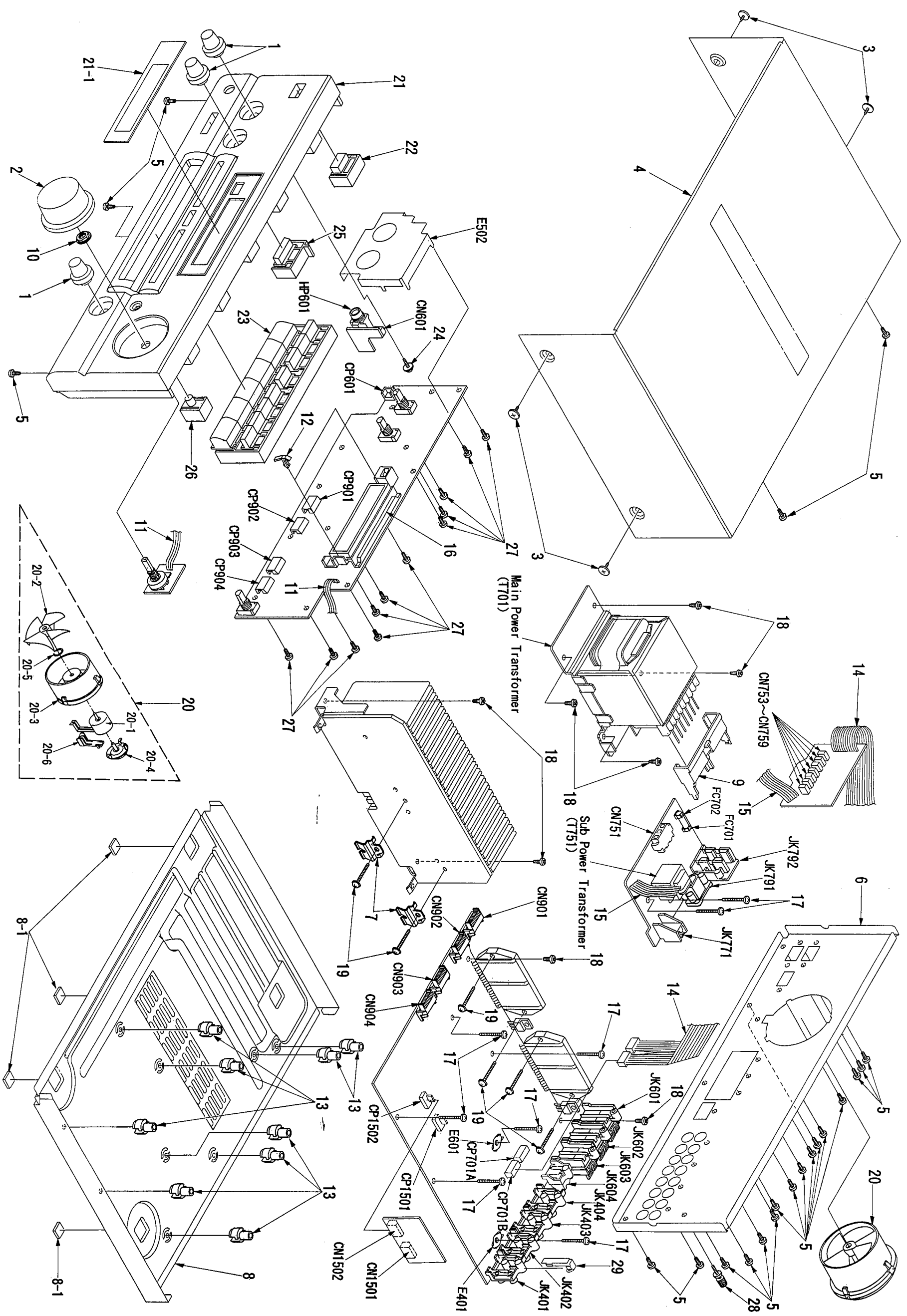

REPLACEMENT PARTS LIST

\*Important safety notices: Components identified by Δ mark have special characteristics important for safety. Furthermore, special parts which have purposes of fire-retardant (resistors), high-quality sound (capacitors), low-noise (resistors), etc. are used. When replacing any of components, be sure to use only manufacturer's specified parts shown in the parts list.

Part No.	Part Name & Description	Remarks	Ref. No.	Part No.	Part Name & Description	Remarks
	INTEGRATED CIRCUIT (S)		Q1101, 1102	ZSC3311A1RTA	TRANSISTOR	
			Q1103	ZSA1309A1RTA	TRANSISTOR	
			Q1501, 1502	ZSC3311A1RTA	TRANSISTOR	
			Q1503	UN4211	TRANSISTOR	
ME218AP	BUFFER AMP					
AN6558-FSG	PHONO EQ. AMP					
ME218AP	BUFFER AMP					
ME218AP	BUFFER AMP					
UPC4570C	TOUR AMP		D571	MA165	DIODE	
TC9212P	ATTENUATOR		D601, 602	S83606501T	DIODE	
ME218AP	SUPER BASS AMP		D603	MA4082MTA	DIODE	
BSN3306	POWER AMP (FRONT)	Δ	D604-606	MA165	DIODE	
SV13204B	POWER AMP (CENTER/REAR)	Δ	D607, 608	MA4033TA	DIODE	
LC8A008S477	MICROCOMPUTER		D609	MA165	DIODE	
LA2785	DOLBY PRO LOGIC CONTROL		D654, 655	MA165	DIODE	
LV1010	DOLBY PRO LOGIC DRIVE		D656	MA4047MTA	DIODE	
TC9214P	SURROUND SELECTOR		D657	MA165	DIODE	
AN6554F	BUFFER AMP		D701-704	P300D5002T	DIODE	Δ
TC9212P	ATTENUATOR		D705	MA4150M	DIODE	Δ
ME218L	SIGNAL DETECTOR		D707	MA4220MTA	DIODE	Δ
			D708	MA4150M	DIODE	Δ
			D721-724	P300DLF	DIODE	Δ
			D731	MA4360MTA	DIODE	Δ
			D732, 733	MA165	DIODE	
			D751-754	1SR35200TB	DIODE	Δ
ZSK301RST7A	TRANSISTOR		D755	MA165	DIODE	
UN4111	TRANSISTOR		D756	MA4068M	DIODE	Δ
ZSC3311A1RTA	TRANSISTOR		D771	MA165	DIODE	
ZSA1309A1RTA	TRANSISTOR		D772	MA4082MTA	DIODE	Δ
UN4111	TRANSISTOR		D773	MA165	DIODE	
ZSA1309A1RTA	TRANSISTOR		D901, 902	1SS291TA	DIODE	
ZSC3311A1RTA	TRANSISTOR		D903	MA165	DIODE	
ZSD1761DEF	TRANSISTOR	Δ	D904	MA4039MTA	DIODE	Δ
ZSB621AQST7A	TRANSISTOR	Δ	D905	MA165	DIODE	
ZSB1187DEF	TRANSISTOR	Δ	D906	MA4058MTA	DIODE	Δ
ZSB1357DEF7A	TRANSISTOR	Δ	D907	MA165	DIODE	
ZSC3311A1RTA	TRANSISTOR	Δ	D1001	MA4100MTA	DIODE	Δ
ZSD2037DEF7A	TRANSISTOR	Δ	D1101	MA165	DIODE	
ZSA992EFP7A	TRANSISTOR	Δ	D1501, 1502	MA4068M	DIODE	
ZSA992EFP7A	TRANSISTOR	Δ	D1503	MA700	DIODE	
UN421FTA	TRANSISTOR	Δ	D1504	MA165	DIODE	
ZSC3940AQST7A	TRANSISTOR	Δ				
ZSA1309A1RTA	TRANSISTOR	Δ	VR511, 512	EVJVALF02C15	TONE CONT. BASS/TREBLE	
ZSC3940AQST7A	TRANSISTOR	Δ	VR551	EVJ02QF02G15	BALANCE	
ZS1A0C7A	TRANSISTOR	Δ	VR901	EVQWQAF25248	VOLUME	

Ref. No.	Part No.	Part Name & Description	Remarks	Ref. No.	Part No.	Part Name & Description	Remarks
		COIL (S)		RL601-603	RSY0013M-0	RELAY	Δ
		COIL		RL751	RSY0019M-0	RELAY	Δ
L601, 602	RLQYR73M	COIL				CONNECTOR (S) AND SOCKET (S)	
L651, 652	RLQYR73M	COIL					
L751	ELEPK101KA	COIL					
L901	RLQZP10KT-V	COIL					
L1051	ELEPK101KA	COIL					
		TRANSFORMER (S)					
T701	RTP1P50016-V	POWER TRANSFORMER (MAIN)	Δ				
T751	RTP1P50016-V	POWER TRANSFORMER (SUB)	Δ				
		COMPONENT COMBINATION (S)					
Z901	RCDHC-278M	REMOTE SENSOR					
		OSCILLATOR (S)					
CF901	EP0E6004T4	OSCILLATOR (6MHz)					
CF1051	EP0E8004T4	OSCILLATOR (8MHz)					
		DISPLAY TUBE (S)					
FL901	BSL0167-F	DISPLAY TUBE					
		FUSE (S)					
F1	XBALG53NB4U	FUSE, 125V 6.3A	Δ				
		SWITCH (ES)					
S901	EVQ21405R	SPEAKERS					
S902	EVQ21405R	VCR1					
S903	EVQ21405R	EQ/VCR2					
S904	EVQ21405R	TAPE/DCG-					
S905	EVQ21405R	CD					
S906	EVQ21405R	TUNER					
S907	EVQ21405R	PHONO					
S908	EVQ21405R	REAR LEVEL -					
S909	EVQ21405R	CENTER LEVEL -					
S910	EVQ21405R	POWER					
S913	EVQ21405R	SURROUND					
S914	EVQ21405R	3 STEREO					
S915	EVQ21405R	CENTER MODE					
S916	EVQ21405R	TEST					
S917	EVQ21405R	REAR LEVEL +					
S918	EVQ21405R	CENTER LEVEL +					
S919	EVQ21405R	SUPER BASS					
		RELAY (S)					



# RESISTORS AND CAPACITORS

Notes : \* Capacity values are in microfarads ( $\mu\text{F}$ ) unless specified otherwise, P=Pico-farads (pF) F=Farads (F)  
 \* Resistance values are in ohms, unless specified otherwise, 1 K=1,000 (OHM), 1 M=1,000 k (OHM)

Ref. No.	Part No.	Values & Remarks	Ref. No.	Part No.	Values & Remarks	Ref. No.	Part No.	Values & Remarks
		RESISTORS	R601, 602	ERDS2TJ102	1/4W 1K	R706	ERDS2TJ471	1/4W 470
			R603, 604	ERDS2TJ563	1/4W 56K	R721	ERDS1FVJ6R8T	1/2W 6.8 $\Delta$
			R605, 606	ERDS2TJ182	1/4W 1.8K	R722	ERD25FJ101	1/4W 100 $\Delta$
R401-404	ERDS2TJ102	1/4W 1K	R607, 608	ERDS2TJ563	1/4W 56K	R723	ERDS2TJ472	1/4W 4.7K
R405, 406	ERDS2TJ104	1/4W 100K	R609, 610	ERDS2TJ470	1/4W 47	R724	ERDS1FVJ100T	1/2W 10 $\Delta$
R407-416	ERDS2TJ102	1/4W 1K	R611, 612	ERDS1FVJ100T	1/2W 10 $\Delta$	R725	ERDS2TJ152	1/4W 1.5K
R421, 422	ERDS2TJ102	1/4W 1K	R613, 614	ERDS2TJ102	1/4W 1K	R727	ERD25FVJ5R6T	1/4W 5.6 $\Delta$
R423-425	ERDS2TJ103	1/4W 10K	R615	ERDS2TJ184T	1/4W 180K	R731	ERD25FVJ180T	1/4W 18 $\Delta$
R431, 432	ERDS2TJ102	1/4W 1K	R616	ERDS2TJ154	1/4W 150K	R732	ERDS2TJ153	1/4W 15K
R433, 434	ERDS2TJ104	1/4W 100K	R617, 618	ERDS2TJ473	1/4W 47K	R733	ERDS2TJ273	1/4W 27K
R435, 436	ERDS2TJ473	1/4W 47K	R619	ERDS2TJ223	1/4W 22K	R734	ERDS2TJ223	1/4W 22K
R437, 438	ERDS2TJ104	1/4W 100K	R620	ERD25FJ220	1/4W 22 $\Delta$	R735	ERDS2TJ333	1/4W 33K
R451, 452	ERDS2TJ224T	1/4W 220K	R621	ERDS2TJ183T	1/4W 18K	R739	ERD25FVJ180T	1/4W 18 $\Delta$
R453, 454	ERDS2TJ821	1/4W 820	R622	ERDS2TJ124T	1/4W 120K	R740	ERDS2TJ393	1/4W 39K
R455, 456	ERDS2TJ563	1/4W 56K	R623	ERDS2TJ684	1/4W 680K	R742	ERDS2TJ393	1/4W 39K
R457, 458	ERDS2TJ271	1/4W 270	R624, 625	ERDS2TJ563	1/4W 56K	R743	ERDS2TJ183T	1/4W 18K
R459, 460	ERDS2TJ680T	1/4W 68	R628	ERDS2TJ223	1/4W 22K	R754	ERDS2TJ102	1/4W 1K
R461, 462	ERDS2TJ184T	1/4W 180K	R629, 630	ERDS2TJ472	1/4W 4.7K	R772	ERDS2TJ104	1/4W 100K
R463, 464	ERDS2TJ123	1/4W 12K	R631, 632	ERDS2TJ103	1/4W 10K	R773	ERDS2TJ103	1/4W 10K
R465, 466	ERDS2TJ563	1/4W 56K	R633, 634	ERDS2TJ222	1/4W 2.2K	R774	ERDS2TJ223	1/4W 22K
R467, 468	ERDS2TJ102	1/4W 1K	R635, 636	ERDS1FVJ821T	1/2W 820 $\Delta$	R775	ERDS2TJ332	1/4W 3.3K
R501, 502	ERDS2TJ332	1/4W 3.3K	R637-640	ERG1SJ101E	1W 100	R776	ERDS1FVJ150T	1/2W 15 $\Delta$
R503-506	ERDS2TJ224T	1/4W 220K	R641	ERDS2TJ684	1/4W 680K	R777	ERDS2TJ150T	1/4W 15
R511, 512	ERDS2TJ471	1/4W 470	R651, 652	ERDS2TJ102	1/4W 1K	R778	ERDS2TJ222	1/4W 2.2K
R513, 514	ERDS2TJ104	1/4W 100K	R653, 654	ERDS2TJ563	1/4W 56K	R779	ERDS2TJ103	1/4W 10K
R515, 516	ERDS2TJ474	1/4W 470K	R655, 656	ERDS2TJ182	1/4W 1.8K	R780, 781	ERDS2TJ333	1/4W 33K
R517, 518	ERDS2TJ471	1/4W 470	R657, 658	ERDS2TJ563	1/4W 56K	R782	ERDS2TJ153	1/4W 15K
R519, 520	ERDS2TJ182	1/4W 1.8K	R659, 660	ERDS2TJ470	1/4W 47	R783	ERDS2TJ103	1/4W 10K
R521, 522	ERDS2TJ223	1/4W 22K	R661, 662	ERDS1FVJ100T	1/2W 10 $\Delta$	R791-796	ERDS2TJ223	1/4W 22K
R523, 524	ERDS2TJ392T	1/4W 3.9K	R665	ERDS2TJ563	1/4W 56K	R797	ERDS2TJ682T	1/4W 6.8K
R525, 526	ERDS2TJ222	1/4W 2.2K	R666	ERDS2TJ104	1/4W 100K	R901	ERDS2TJ102	1/4W 1K
R527, 528	ERDS2TJ122	1/4W 1.2K	R667	ERD25FJ101	1/4W 100 $\Delta$	R903	ERDS2TJ104	1/4W 100K
R529, 530	ERDS2TJ473	1/4W 47K	R668	ERDS2TJ154	1/4W 150K	R904	ERDS2TJ472	1/4W 4.7K
R551, 552	ERDS2TJ471	1/4W 470	R669	ERDS2TJ223	1/4W 22K	R905	ERDS2TJ271	1/4W 270
R553, 554	ERDS2TJ102	1/4W 1K	R670	ERD25FJ470	1/4W 47 $\Delta$	R906	ERDS2EJ121	1/4W 120
R555, 556	ERDS2TJ563	1/4W 56K	R671	ERDS2TJ103	1/4W 10K	R911, 912	ERDS2TJ104	1/4W 100K
R557, 558	ERDS2TJ682T	1/4W 6.8K	R673	ERDS2TJ684	1/4W 680K	R913, 914	ERDS2TJ102	1/4W 1K
R559, 560	ERDS2TJ824	1/4W 820K	R674	ERDS2TJ473	1/4W 47K	R915	ERDS2TJ104	1/4W 100K
R565	ERDS2TJ563	1/4W 56K	R676	ERDS2TJ223	1/4W 22K	R916, 917	ERDS2TJ101	1/4W 100
R566	ERDS2TJ224T	1/4W 220K	R677	ERDS2TJ103	1/4W 10K	R921	ERDS2TJ104	1/4W 100K
R567-569	ERDS2TJ332	1/4W 3.3K	R678	ERDS1FVJ821T	1/2W 820 $\Delta$	R922-927	ERDS2TJ102	1/4W 1K
R571, 572	ERDS2TJ474	1/4W 470K	R679	ERDS2TJ222	1/4W 2.2K	R928	ERDS2TJ104	1/4W 100K
R573, 574	ERDS2TJ222	1/4W 2.2K	R680	ERDS2TJ333	1/4W 33K	R929-933	ERDS2TJ102	1/4W 1K
R575, 576	ERDS2TJ102	1/4W 1K	R681-694	ERDS2TJ270T	1/4W 27	R950	ERDS2TJ103	1/4W 10K
R577	ERDS2TJ152	1/4W 1.5K	R695, 696	ERDS2TJ102	1/4W 1K	R951	ERDS2TJ102	1/4W 1K
R578	ERDS2TJ474	1/4W 470K	R699	ERDS2TJ332	1/4W 3.3K	R952	ERDS2TJ122	1/4W 1.2K
R579	ERDS2TJ822	1/4W 8.2K	R700	ERDS2TJ474	1/4W 470K	R953	ERDS2TJ152	1/4W 1.5K
R580	ERDS2TJ472	1/4W 4.7K	R703, 704	ERDS1FVJ100T	1/2W 10 $\Delta$	R954	ERDS2TJ182	1/4W 1.8K
R581, 582	ERDS2TJ224T	1/4W 220K	R705	ERDS2TJ472	1/4W 4.7K	R955	ERDS2TJ222	1/4W 2.2K

Ref. No.	Part No.	Values & Remarks	Ref. No.	Part No.	Values & Remarks	Ref. No.	Part No.	Values & Remarks
R956	ERDS2TJ332	1/4W 3.3K	R1510	ERDS2TJ472	1/4W 4.7K	C617	ECEA1JU220	63V 22U
R957	ERDS2TJ472	1/4W 4.7K	R1511	ERDS2TJ104	1/4W 100K	C618	ECEA2AN2R2SB	100V 2.2U
R958	ERDS2TJ682T	1/4W 6.8K	R1512	ERDS2TJ392T	1/4W 3.9K	C621, 622	ECEA2AU100	100V 10U
R960	ERDS2TJ103	1/4W 10K	R1513	ERDS2TJ223	1/4W 22K	C651, 652	ECEA1HKN3R3B	50V 3.3U
R961	ERDS2TJ222	1/4W 2.2K	R1514	ERDS2TJ101	1/4W 100	C653, 654	ECBA1H681KB5	50V 680P
R963	ERDS2TJ152	1/4W 1.5K	R1515	ERDS2TJ223	1/4W 22K	C655, 656	ECEA1CKA220B	16V 22U
R964	ERDS2TJ182	1/4W 1.8K				C657, 658	ECCR1H100K5	50V 10P
R965	ERDS2TJ222	1/4W 2.2K			CAPACITORS	C659, 660	ECBT1H151KB5	50V 150P
R966	ERDS2TJ332	1/4W 3.3K				C661, 662	ECQV1H473JM3	50V 0.047U
R967	ERDS2TJ472	1/4W 4.7K	C401-414	ECBT1H101KB5	50V 100P	C665	ECA1HM470B	50V 47U
R968	ERDS2TJ682T	1/4W 6.8K	C419, 420	ECEA1VKA4R7B	35V 4.7U	C667	ECEA1JU220	63V 22U
R1001, 1002	ERDS2TJ222	1/4W 2.2K	C421, 422	ECBT1E103ZF	25V 0.01U	C668	ECEA2AU100	100V 10U
R1003, 1004	ERDS2TJ102	1/4W 1K	C423	ECBT1H101KB5	50V 100P	C669	ECEA2AN2R2SB	100V 2.2U
R1005	ERDS2TJ203T	1/4W 20K	C425, 426	ECEA1CKA100B	16V 10U	C681, 682	ECEA1HN100SB	50V 10U
R1007, 1008	ERDS2TJ473	1/4W 47K	C431, 432	ECBT1H101KB5	50V 100P	C685	ECBT1H331KB5	50V 330P
R1009-1011	ERDS2TJ332	1/4W 3.3K	C433-436	ECEA1CKA100B	16V 10U	C701	ECBT1E103ZF	25V 0.01U
R1012	ERDS2TJ102	1/4W 1K	C451, 452	ECEA1VKA4R7B	35V 4.7U	C702	ECQE2104KF3	250V 0.1U
R1013	ERDS2TJ103	1/4W 10K	C453, 454	ECBT1H101KB5	50V 100P	C703, 704	ECET1K123VWX	80V 12000U Δ
R1014	ERDS2TJ104	1/4W 100K	C455, 456	ECBT1H102KB5	50V 1000P	C705, 706	ECA1JM222B	63V 2200U Δ
R1051	ERDS2TJ393	1/4W 39K	C457, 458	ECEA1AKA330B	10V 33U	C707	ECA1VM101B	35V 100U
R1052	ERDS2TJ105T	1/4W 1M	C459, 460	ECFR1E223KR	25V 0.022U	C708	ECKR1H103ZF5	50V 0.01U
R1053	ERDS2TJ102	1/4W 1K	C461, 462	ECFR1E682KR	25V 6800P	C711	ECKR1H103ZF5	50V 0.01U
R1055, 1056	ERDS2TJ473	1/4W 47K	C463, 464	ECEA1VKA4R7B	35V 4.7U	C712	ECEA1HKA100B	50V 10U
R1057	ERDS2TJ564	1/4W 560K	C465, 466	ECBT1E103ZF	25V 0.01U	C713	ECKR1H103ZF5	50V 0.01U
R1058, 1059	ERDS2TJ274	1/4W 270K	C501, 502	ECEA1VKA4R7B	35V 4.7U	C714	ECEA1CKA470B	16V 47U
R1060	ERDS2TJ104	1/4W 100K	C503, 504	ECBT1H101KB5	50V 100P	C721	ECQE2104KF3	250V 0.1U
R1061	ERDS2TJ222	1/4W 2.2K	C505, 506	ECEA1CKA100B	16V 10U	C731, 732	ECKR1H103ZF5	50V 0.01U
R1101, 1102	ERDS2TJ222	1/4W 2.2K	C513, 514	ECBT1H150J5	50V 15P	C751	ECKWNS102MBM	400V 1000P Δ
R1103, 1104	ERDS2TJ682T	1/4W 6.8K	C515, 516	ECBT1H221KB5	50V 220P	C752	ECKR1H103ZF5	50V 0.01U
R1105, 1106	ERDS2TJ474	1/4W 470K	C517, 518	ECBT1H470J5	50V 47P	C753	ECA1EM102B	25V 1000U Δ
R1107, 1108	ERDS2TJ102	1/4W 1K	C519-522	ECEA1VKA4R7B	35V 4.7U	C754	ECBT1E103ZF	25V 0.01U
R1109, 1110	ERDS2TJ104	1/4W 100K	C523, 524	ECFR1E123KR	25V 0.012U	C755	ECEA1CKA470B	16V 47U
R1111, 1112	ERDS2TJ122	1/4W 1.2K	C525, 526	ECQV1H683JM3	50V 0.068U	C756	ECBT1E103ZF	25V 0.01U
R1113, 1114	ERDS2TJ822	1/4W 8.2K	C527, 528	ECFR1E562KR	25V 5600P	C758	ECEA1AKA101B	10V 100U
R1115, 1116	ERDS2TJ474	1/4W 470K	C529, 530	ECFR1E273KR	25V 0.027U	C771	ECEA1HKA2R2B	50V 2.2U
R1117, 1118	ERDS2TJ224T	1/4W 220K	C531, 532	ECBT1E103ZF	25V 0.01U	C772	ECEA1CKA100B	16V 10U
R1119-1121	ERDS2TJ332	1/4W 3.3K	C535, 536	ECEA1CKA100B	16V 10U	C773	ECBT1E223ZF	25V 0.022U
R1131, 1132	ERDS2TJ332	1/4W 3.3K	C551-554	ECQV1H104JM3	50V 0.1U	C774	ECEA0JKA221B	6.3V 220U
R1133, 1134	ERDS2TJ102	1/4W 1K	C555-558	ECEA1CKA100B	16V 10U	C901	ECA0JM102B	6.3V 1000U
R1135	ERDS2TJ474	1/4W 470K	C559, 560	ECBT1E103ZF	25V 0.01U	C902	ECBT1E103ZF	25V 0.01U
R1136	ERDS2TJ103	1/4W 10K	C561-563	ECBT1H101KB5	50V 100P	C903	ECEA0JKA101B	6.3V 100U
R1137	ERDS2TJ332	1/4W 3.3K	C571, 572	ECEA1VKA4R7B	35V 4.7U	C904	ECEA1CKA100B	16V 10U
R1138	ERDS2TJ104	1/4W 100K	C573	ECEA1HKN010B	50V 1U	C905	ECA0JM471B	6.3V 470U
R1139	ERDS2TJ472	1/4W 4.7K	C601, 602	ECEA1HKN3R3B	50V 3.3U	C906	ECEA0JKA101B	6.3V 100U
R1140	ERDS2TJ152	1/4W 1.5K	C603, 604	ECBT1H471KB5	50V 470P	C907	ECBT1H101KB5	50V 100P
R1501, 1502	ERDS2TJ223	1/4W 22K	C605, 606	ECEA1JU220	63V 22U	C908	ECBT1H104ZF5	50V 0.1U
R1503	ERDS2TJ684	1/4W 680K	C607, 608	ECCR1H100K5	50V 10P	C909, 910	ECEA1HKA010B	50V 1U
R1504	ERDS2TJ103	1/4W 10K	C609, 610	ECBT1H151KB5	50V 150P	C911	ECBT1E103ZF	25V 0.01U
R1505	ERDS2TJ104	1/4W 100K	C611, 612	ECQV1H473JM3	50V 0.047U	C912, 913	ECEA2AU100	100V 10U
R1506	ERDS2TJ102	1/4W 1K	C613, 614	ECBA1H681KB5	50V 680P	C914, 915	ECEA1VKA100B	35V 10U
R1507	ERDS2TJ104	1/4W 100K	C615	ECA1HM470B	50V 47U	C921-928	ECBT1H331KB5	50V 330P
R1508, 1509	ERDS2TJ103	1/4W 10K	C616	ECEA2AU100	100V 10U	C931-934	ECBT1H101KB5	50V 100P

Ref. No.	Part No.	Values & Remarks	Ref. No.	Part No.	Values & Remarks	Ref. No.	Part No.	Values & Remarks
C1001, 1002	ECEA1HKA010B	50V 1U	C1028	ECEA1HKAR47B	50V 0.47U	C1058	ECFR1E333KR	25V 0.033U
C1003, 1004	ECEA1HKA3R3B	50V 3.3U	C1029	ECEA1VKA4R7B	35V 4.7U	C1059	ECEA1CKA101B	16V 100U
C1005	ECEA1HKA010B	50V 1U	C1030	ECEA1HKAR47B	50V 0.47U	C1060	ECBT1E223ZF	25V 0.022U
C1007	ECFR1E223KR	25V 0.022U	C1031, 1032	ECQV1H104JM3	50V 0.1U	C1062	ECBT1E223ZF	25V 0.022U
C1008	ECFR1E473KR	25V 0.047U	C1033	ECEA1CKA470B	16V 47U	C1063	ECEA1CKA101B	16V 100U
C1009	ECEA0JKA221B	6.3V 220U	C1034	ECQV1H474JM3	50V 0.47U	C1064	ECBT1H104ZF5	50V 0.1U
C1010-1013	ECEA1CKA100B	16V 10U	C1035	ECBA1H681KB5	50V 680P	C1065	ECBA1H681KB5	50V 680P
C1014	ECEA0JKA221B	6.3V 220U	C1036-1038	ECBT1H101KB5	50V 100P	C1101-1108	ECEA1HKA3R3B	50V 3.3U
C1015, 1016	ECQV1H104JM3	50V 0.1U	C1039	ECEA1CKA101B	16V 100U	C1109-1111	ECBT1H101KB5	50V 100P
C1017	ECEA1HKAR47B	50V 0.47U	C1040	ECEA1CKA100B	16V 10U	C1113, 1114	ECEA1CKA100B	16V 10U
C1018	ECEA1VKA4R7B	35V 4.7U	C1041	ECBT1E103ZF	25V 0.01U	C1115, 1116	ECBT1E103ZF	25V 0.01U
C1019	ECEA1HKAR47B	50V 0.47U	C1043, 1044	ECBT1E103ZF	25V 0.01U	C1131	ECEA1HKN010B	50V 1U
C1020	ECEA1VKA4R7B	35V 4.7U	C1051	ECEA1HKA2R2B	50V 2.2U	C1132	ECEA1HKA3R3B	50V 3.3U
C1021	ECEA1HKAR15B	50V 0.15U	C1052	ECEA1HKA010B	50V 1U	C1501	ECEA1HKA3R3B	50V 3.3U
C1022	ECEA1HKA3R3B	50V 3.3U	C1053	ECEA1HKA3R3B	50V 3.3U	C1502	ECEA1HKA010B	50V 1U
C1023, 1024	ECQV1H154JM3	50V 0.15U	C1054	ECEA0JKA221B	6.3V 220U	C1503	ECEA1HKA2R2B	50V 2.2U
C1025	ECEA1HKA3R3B	50V 3.3U	C1055	ECEA1HKA010B	50V 1U	C1504	ECEA1HKA010B	50V 1U
C1026	ECEA1HKAR15B	50V 0.15U	C1056	ECFR1E333KR	25V 0.033U	C1505, 1506	ECEA1HKA3R3B	50V 3.3U
C1027	ECEA1VKA4R7B	35V 4.7U	C1057	ECFR1E152KR	25V 1500P			

## PACKAGING

