



For more Hi-Fi manuals and set-up information
please visit www.hifiengine.com

TEAC®

**SERVICE
MANUAL
A-4300SX**

Stereo Tape Deck



TEAC CORPORATION

51031780

1. GENERAL DESCRIPTION

The TEAC A-4300SX is an excellent home entertainment stereo tape deck built to semi-professional standards, with 3 motors, 4 heads, foil sensing auto-reverse and index-counter repeat. It operates at 3-3/4 ips and 7-1/2 ips, accepts 7" reels, and features switch-controlled Bias and Equalization; dual range VU meter; two line input jacks per channel; remote controlled (optional) operation; and other convenient features.

Although the A-4300 SX internally appears to be similar to A-4300, significant differences require that you consult this manual before attempting service. The A-4300SX Service Manual/Parts Manual contains adjustment and alignment information, schematic diagram, parts replacement references, and other information for obtaining new parts.



TABLE OF CONTENTS

1. General Description	3
2. Specification and Service Data	4
3. Tools for Testing and Maintenance	5
4. Partial Dis-assembly	6
5. Tape Transport Parts Location	8
6. Head Replacement and Alignment	9
7. Measurement and Adjustment	10
--MECHANICAL--	
8. Measurement and Adjustment	13
--ELECTRICAL--	
9. Trouble-shooting	20
10. Service and Maintenance	22
11. Simplified Schematic with level indications	23

2. SPECIFICATIONS AND SERVICE DATA

2-1 SPECIFICATIONS

Track System	1/4 track 2 channel stereophonic 1/4 track 1 channel monophonic
Heads	Four; Erase, Record and Playback x 2
Reel Size	7" maximum
Tape Speed	7-1/2 ips and 3-3/4 ips
Motors	1 Dual-Speed Hysteresis Synchronous Capstan motor 2 Eddy Current Induction Reel motors
Input (Level and Impedance)	MIC: Specified; -60 dB (0.774 mV)/10k ohms Minimum; -70 dB (0.244 mV) LINE: Specified; -8 dB (308 mV)/50k ohms Minimum; -18 dB (97 mV) DIN: Minimum; -38 dB (9.75 mV)
Output (Level and Impedance)	LINE: Specified; -8 dB (308 mV)/10k ohms Maximum; -2 dB (615 mV) DIN: Maximum; -2 dB (615 mV)
Playback Equalization	7-1/2 ips: NAB 3180 μ sec, 50 μ sec 3-3/4 ips: NAB 3180 μ sec, 90 μ sec
Bias Frequency	100k Hz (\pm 5k Hz, push-pull oscillator)
Power Requirement	100, 117, 220, 240 V AC 50/60 Hz (General Export model) 117 V AC 60 Hz (U.S.A. and Canada Model)
Weight	23 kg (51 lbs) net
Power Consumption	90 W
Dimensions (WHD)	440 x 488 x 216 mm (17-5/16" x 19-1/4" x 8-1/2")

2-2 SERVICE DATA -MECHANICAL-

Tape Speed Deviation and Drift	3,000 Hz \pm 30 Hz, within 15 Hz
Wow and Flutter	Playback: 0.18% (RMS) at 7-1/2 ips 0.20% (RMS) at 3-3/4 ips Overall: 0.20% (RMS) at 7-1/2 ips 0.25% (RMS) at 3-3/4 ips
Pinch Roller Pressure	2.4 kg (5.3 lbs)
Reel Torque	TAKE-UP: FWD 370 to 410 g·cm (5.2 to 5.7 oz-inch) REV 430 to 470 g·cm (6.0 to 6.6 oz-inch) BACK TENSION: FWD 170 to 210 g·cm (2.4 to 2.9 oz-inch) REV 180 to 220 g·cm (2.5 to 3.1 oz-inch)
Brake Torque	800 to 1,200 g·cm (11 to 17 oz-inch)
F.F/REW Time	160 seconds for 1,800 foot tape

2-3 SERVICE DATA -ELECTRICAL-

Frequency Response	Refer to Frequency Response Limits charts in this manual
Signal-To-Noise Ratio	Overall: 48 dB at 7-1/2 ips 46 dB at 3-3/4 ips
Erase Efficiency	68 dB at 1k Hz signal (Measurement with input 10 dB higher than the Specified Input level)
Cross Talk Rejection	40 dB adjacent track at 125 Hz
Stereo Channel Separation	50 dB Channel to Channel at 1k Hz
Total Harmonic Distortion	Overall: 1.5% at 1k Hz signal

NOTE: As a result of continuing changes and improvements during the production run, minor differences may be found between early and later machines. Value of "dB" in this manual refers to 0 dB = 0.775 V.

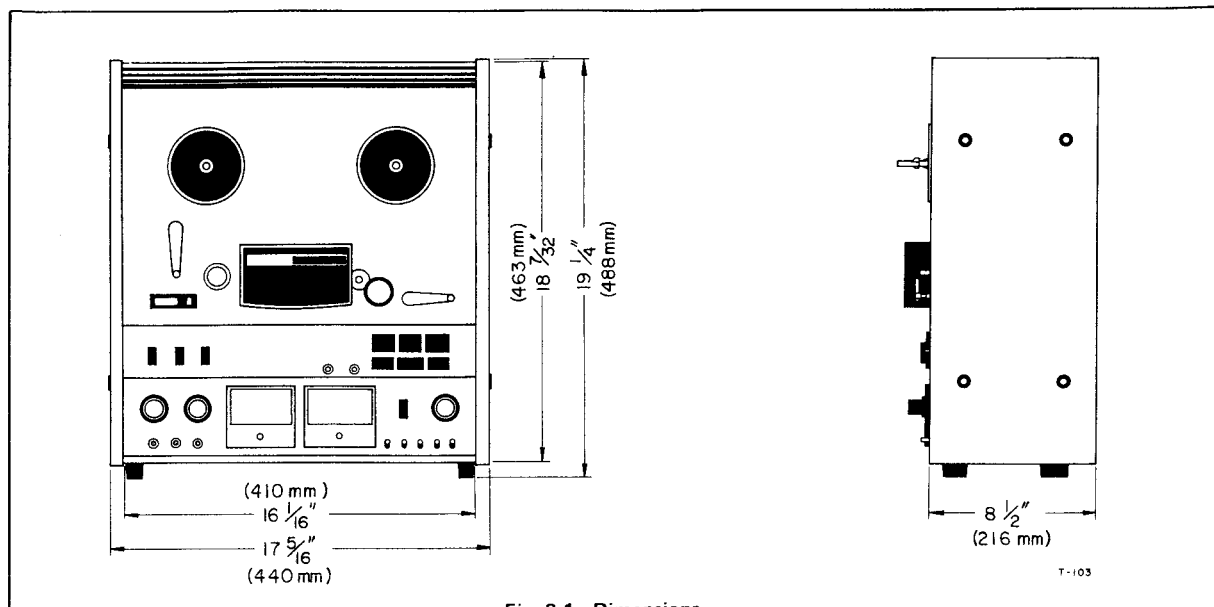

Fig. 2-1 Dimensions

3. TOOLS FOR TESTING AND MAINTENANCE

A minimum of the following tools and test instruments are required for measuring and adjusting to obtain optimum performance. Regular maintenance tools will be adequate for those not listed here. If any test instrument listed here is not available, a close equivalent can be used.

- SPRING SCALE 0-4 kg (0- 8 lbs)
0-300 g (0-10 oz)
- FLUTTER METER Meguro Denpa Sokki K.K.,
Model MK-668A
- DIGITAL COUNTER Range; 0 Hz-100 kHz
- BANDPASS FILTER TEAC MODEL M-206A (1 kHz)
- VTVM (AC) Hewlett-Packard Co., Model 400E
- AF OSCILLATOR 10 Hz-100 kHz
- ATTENUATOR General purpose
- OSCILLOSCOPE General purpose
- BLANK TAPE TEACYTT-8023 and YTT-8003
- TEAC TEST TAPE YTT-1003 (7-1/2 ips), YTT-1002
(3-3/4 ips) for Playback Alignment test
YTT-2003 (7-1/2 ips), YTT-2002
(3-3/4 ips) for Tape Speed
and Wow Flutter test
- TEAC EMPTY REEL RE-702 (2.5" dia, hub)
RE-701 (4" dia, hub)
- TOOLS General
2 mm nut driver
Hex Head Allen Wrench
Plastic alignment tool
Load resistor non inductive type 8 ohm / 1 W
- DEMAGNETIZER TEAC E-3 or equivalent

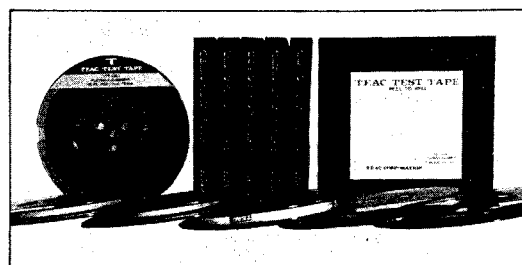

Fig. 3-1 TEAC Test Tape

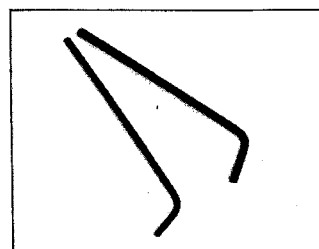

Fig. 3-2 Hex Head (Allen) wrench

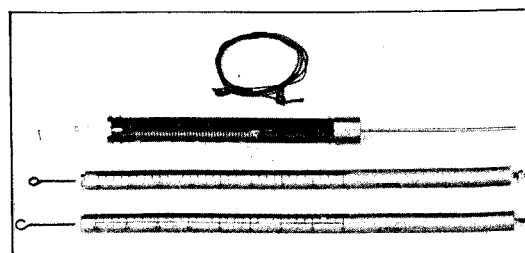

Fig. 3-3 Spring Scales

4. PARTIAL DIS-ASSEMBLY

4-1 REMOVING WOODEN SIDES AND REAR PANEL AND BOTTOM PANEL

See illustration for complete dis-assembly instructions. Most amplifier checks and adjustments can be made from the bottom with the (bottom) panel removed.

These adjustments should be performed by experienced technicians, and then only when going through the complete test and check procedures on the unit which is being tested.

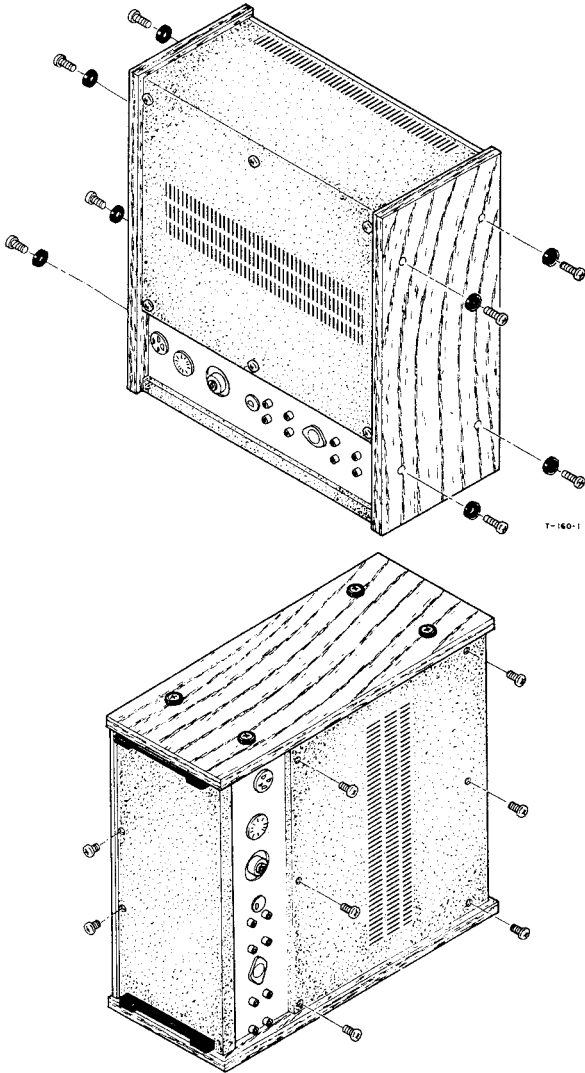

Fig. 4-1 Removing Wooden Sides and Rear and Bottom panels

4-2 HEAD ASSEMBLY REMOVAL

1. Remove the 2 screws in the top of the head cover and lift it off.
2. Remove 2 screws holding head Base plate (with Heads).
3. Remove 2 mounting nuts through access slot in head Base plate and dis-connect head wires. See Fig. 6-2.
4. If necessary, remove Housing Base plate by 4 screws. See Fig. 4-2.

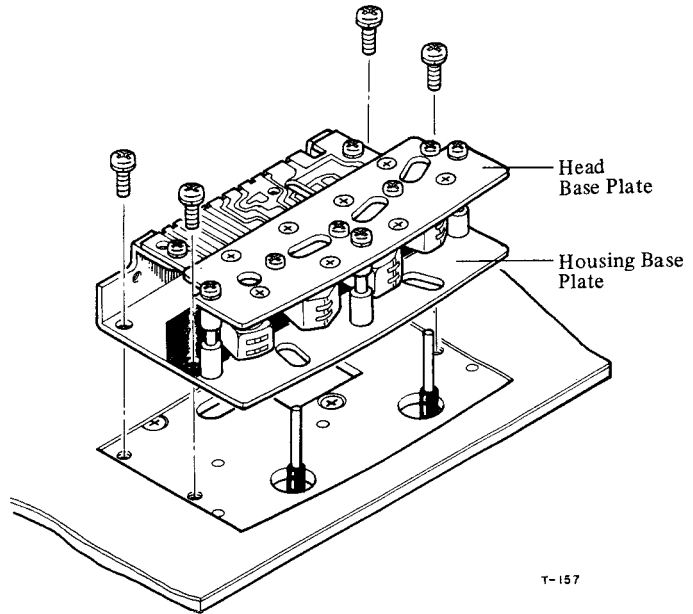

Fig. 4-2 Head Ass'y Removal

4-3 REMOVAL OF CAPSTAN MOTOR

1. Remove the 3 screws holding the capstan motor plate.
2. Unsolder the 6 wires connecting the capstan motor.
3. Remove the 4 screws holding the capstan motor to the motor plate. Watch for the Rubber Cushions (A).
4. Loosen the 2 set screws (hex head) in pulley and lift off pulley (B). Loosen 2 set screws in fan and remove fan.

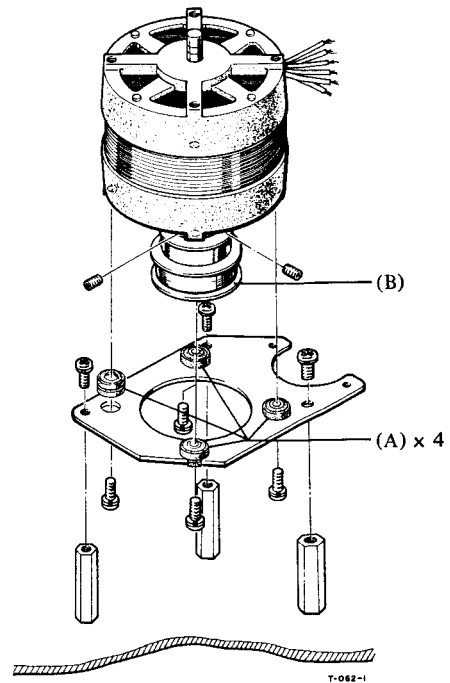

Fig. 4-3 Capstan Motor Removal

4-4 REMOVAL OF CAPSTAN ASSEMBLY

1. Unscrew dust cap (A) on front panel.
2. Remove 2 screws from Thrust Angle (B). Allow bracket to drop toward floor of case.
3. Remove capstan belt (C).
4. Loosen 2 screws in flywheel (D) Remove flywheel.
5. Remove 3 screws in capstan ass'y (E).
6. Gently move capstan ass'y up and down until it slides out of panel.

NOTE: When replacing flywheel, position flywheel on capstan ass'y shaft so that end of shaft protrudes slightly from rear of flywheel. A clearance of approx. 0.01" must be maintained between the end of the capstan shaft and the Thrust Angle.

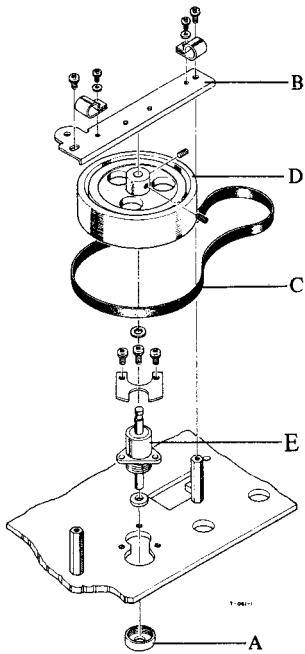

Fig. 4-4 Capstan Ass'y Removal

4-5 REMOVAL OF REEL MOTOR

1. Disconnect the 4 motor wires from terminals and release wire harness straps.
2. Loosen 2 set screws (hex head) in Brake drum (A) and 2 in the Reel Turntable assembly (F). Lift off these parts.
3. Remove 4 screws securing the Brake Assembly (D) to the motor. Carefully lift off the Brake Retainer (B). Do not remove wires connected to the brake solenoid (C).
4. Remove 4 screws securing Reel Motor (E) to chassis through the front panel.

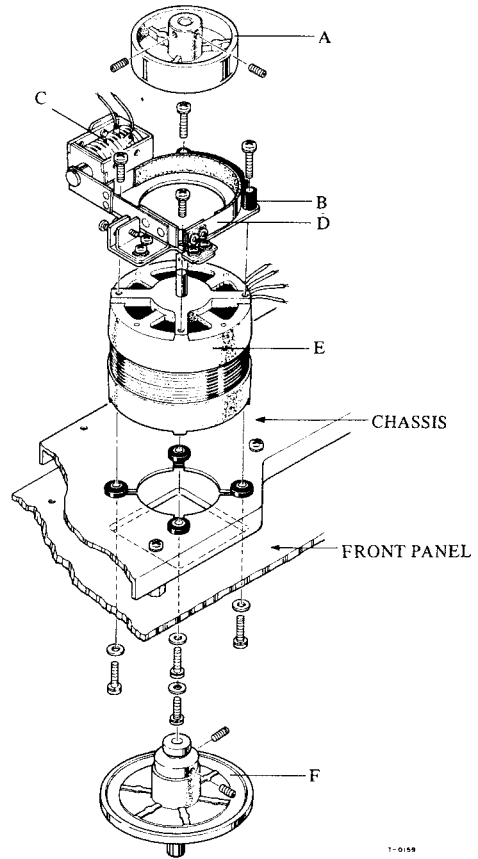

Fig. 4-5 Reel Motor Removal

4-6 REMOVAL OF TENSION ARMS LEFT AND RIGHT

See illustration for complete dis-assembly instructions.

NOTE: After re-assembly check clearance to ascertain that arm moves freely and is not binding. Do not over-tighten screws holding micro-switches. Insulating spacer and micro-switches are easily broken by excess pressure.

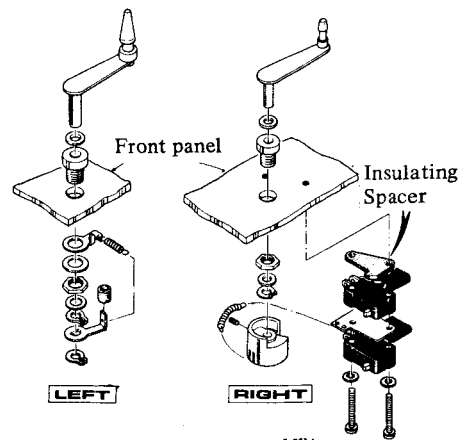
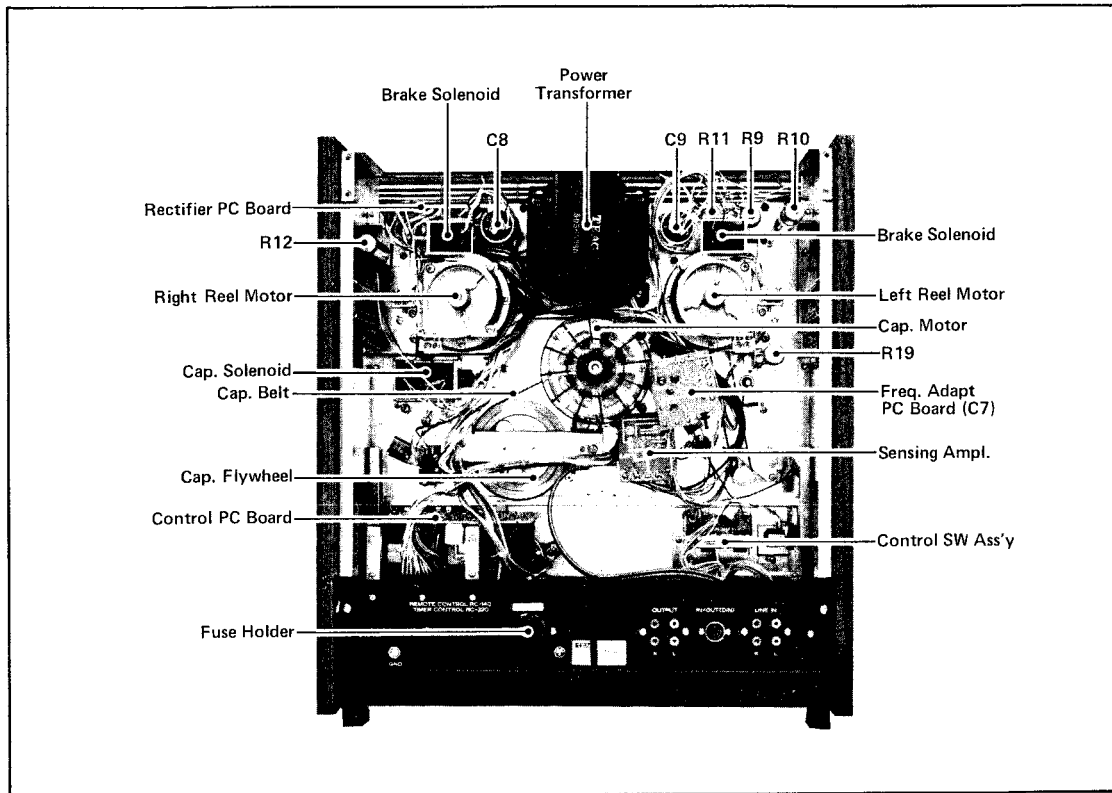

Fig. 4-6 Tension Arms Removal

5. TAPE TRANSPORT PARTS LOCATION

— REAR VIEW —



NOTE: R9, R10 and R11 are adjustable resistors which are used to adjust take-up torque and back tension. Refer to page 11 for the TORQUE MEASUREMENT procedure.

6. HEAD REPLACEMENT AND ALIGNMENT

—MECHANICAL—

6-1 HEAD REPLACEMENT AND WIRING

To replace a single head a special 2 mm nut driver is required. Remove the 2 nuts (A) on the defective head through the access hole provided. This releases the head from the mounting plate. Note the position of the wires on the circuit board. Connect the new head in the same manner. Replace the nuts securing the new head to the plate. Perform head alignment before operation.

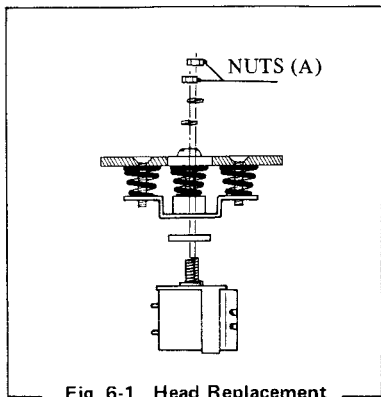

Fig. 6-1 Head Replacement

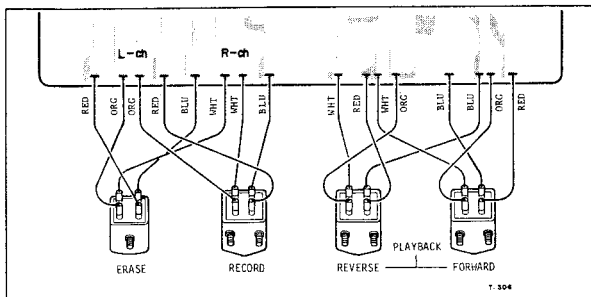

Fig. 6-2 Head Wiring —Rear View —

6-2 HEAD ADJ. SCREWS AND ALIGNMENT

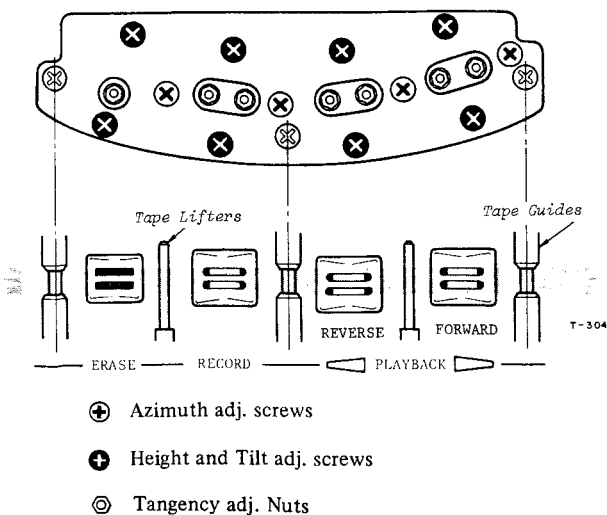

Fig. 6-3 Head Adjustment Screws and Alignment

6-3 VISUAL HEAD ALIGNMENT

Since the propriety of head alignment affects the frequency response on both playback and recording, the head alignment should be done carefully. The head can be adjusted in TILT, TANGENCY, HEIGHT and AZIMUTH. For head alignment, perform the following coarse adjustments first. Then fine alignment should be accomplished electrically while playing back the Test Tape.

Coarse Adjustment:

Without Tape

TILT By Height and tilt screws

This alignment is performed by viewing from the side without tape threaded.

Check that the head surface is parallel to the tape guide surface.

With Tape

TANGENCY By Head mounting Nuts

Loosen the head mounting nuts. Adjust the head so that the vertical alignment of the head gap is perpendicular to the surface of the tape, then tighten the head mounting Nuts.

HEIGHT By Height and Tilt screws

This alignment is checked visually by looking at the position of the head.

The head core for track-1 (inner core) should be even with the inner edge of the tape.

AZIMUTH By Azimuth adj. Screw

Adjust the azimuth adj. screw so that the gap of the head is perpendicular to the tape travel.

NOTE: After this coarse adjustment is made, the adj. screws and the Head mounting nuts should be realigned according to electrical head alignment paragraph which follows in this Service Manual.

6-4 MIS-ALIGNMENT OF THE HEADS

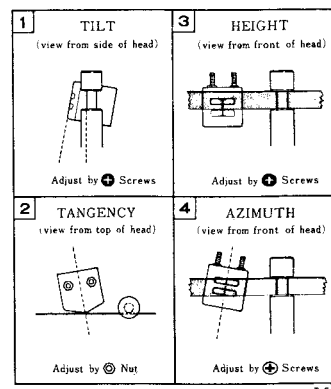

Fig. 7-3 Head Mis-Alignment —Examples—

7. MEASUREMENT AND ADJUSTMENT —MECHANICAL—

7-1 PINCH ROLLER PRESSURE

NOTE: Pinch roller pressure is supplied by the pinch roller spring arm and it is most important that the solenoid plunger be fully bottomed before taking pressure measurement.

1. Load tape or block the shut-off arm in the ON position.
2. Attach a suitable spring scale to the pinch roller shaft.
3. Place the deck in the PLAY mode (▶), and holding the spring scale as illustrated, slowly draw it away from the pinch roller.
4. Do not allow the string to rub against the pinch roller.
5. Note the reading on the spring scale at the instant the pinch roller stops rotating.
6. The scale should indicate 2.3 to 2.5 kg (5.0 to 5.5 lbs). Optimum value is 2.4 kg (5.3 lbs).
7. If adjustment is necessary, loosen the 3 screws on the capstan solenoid and position the solenoid for optimum pressure.
8. Adjust solenoid-limit position so that the gap between capstan shaft and pinch roller is approx. 7 mm when solenoid is not actuated. Also make sure pinch roller shaft does not contact edit arm B. Limit is adjusted by loosening the mounting screw (A), then sliding limit until proper position is obtained.

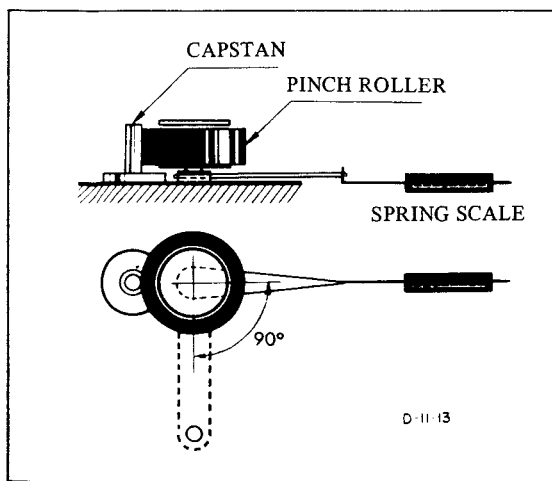
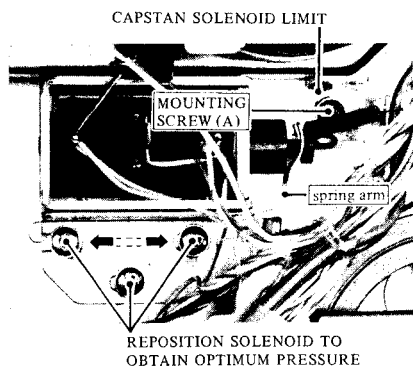

Fig. 7-1 Pressure Measurement and Adj. Locations

7-2 BRAKE TORQUE

The brake torque is actuated mechanically. Pressure is set by the leaf spring force. While making these measurements and adjustments, be careful not to bend the brake bands. As brake torque will change with cleaning, brake drums and brake shoes should be cleaned only when absolutely necessary. If cleaning is required, use TEAC cleaner TZ-261 B. After cleaning, operate the brakes by depressing the play and STOP buttons several times to completely dry out the brakes before performing the following procedure.

NOTE: Brake adjustments are made with NO power connected to the equipment.

1. Place an empty large hub reel on the left reel table, and fasten one end of a 30" length of string to the reel anchor.
2. Wind several turns of string counter clockwise around the hub and attach a suitable spring scale to the free end of the string.
3. Take a reading only when the reel is in steady motion since the force required to overcome static friction will produce a false, excessively high initial reading.
4. The Calculated value should be 800 to 1200 g·cm (11 to 17 oz-in).
5. If adjustment is required, loosen the 2 screws shown and position the brake for optimum torque.
6. The adjustment of the right brake is the same, with the exception that rotation is clockwise. (wind string CLOCKWISE around reel hub)
7. See note at the top of page 11 for explanation of torque measurements.

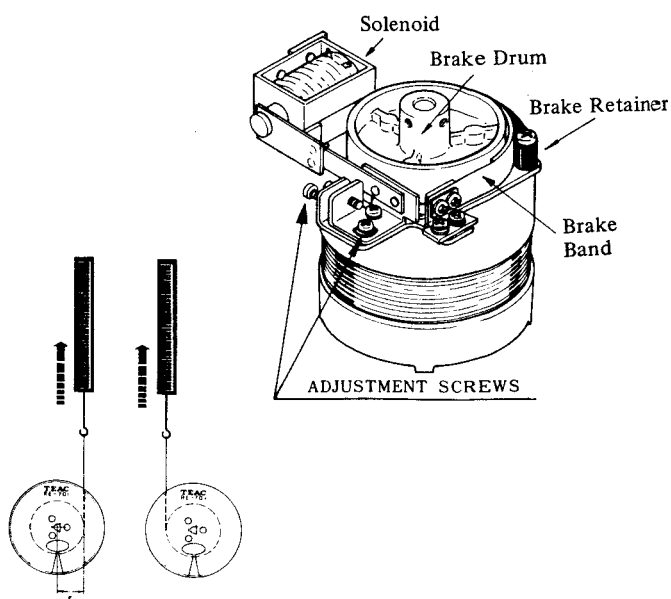

Fig. 7-2 Torque Measurement and Adjustment Location

TORQUE MEASUREMENT PROCEDURE

NOTE: The following torque measurements should be made with a spring scale that is calibrated to read Torque in gram-cm. for a 7" reel with a small reel hub. If the spring scale you are using is calibrated to read Force or Weight in grams the Torque must be calculated using the Formula:

$$\text{Torque (in g}\cdot\text{cm or oz}\cdot\text{in)} = \text{Weight or Force (in gm. or oz.)} \times \text{radius of hub (in cm or inches)}$$

If you are using a reel with other than the standard 2.5" or 6.0 cm (approx.) diameter hub, the Torque must be calculated using the same formula and substituting the actual radius and Weight or Force reading.

All Torque and Tension measurements must be made with the automatic shut-off switch (right tension arm) held in the ON position.

Brake Torque Measurement should be made using large hub reel with a hub diameter of 4" or 10.2 cm.

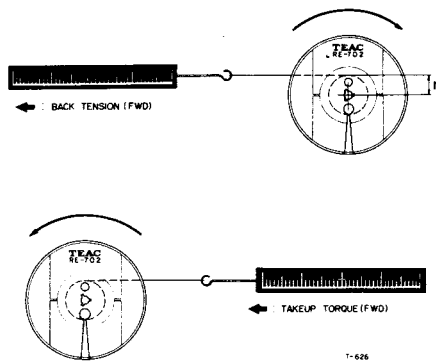

Fig. 7-3 Torque Measurement

7-3 TAKE-UP TORQUE

1. Place the empty reel and attached spring scale on the right reel table.
2. Place the deck in the Forward Play mode.
3. Allow the rotation of the reel to slowly draw the scale toward the hub.
4. Hold the spring scale with enough force to allow a steady reading.
5. The torque calculated value should be approx:
370 to 410 g·cm (5.2 to 5.7 oz-inch)
6. Repeat the procedure for the Reverse play.
430 to 470 g·cm (6.0 to 6.6 oz-inch)

7-4 BACK TENSION

1. Place an empty 7" reel with small hub on the left reel table, and fasten one end of a 30" length of string to the reel anchor.
2. Wind several turns of string counter-clockwise around the hub. Attach spring scale to string.
3. Place the deck in the Forward Play mode.
4. Pull the scale away from the reel against the motor torque with a steady, smooth motion.
5. Note the scale reading while it is in steady motion. (The string must not rub the reel flanges)
6. The calculated value should be approx.:
170 to 210 g·cm (2.4 to 2.9 oz-inch)
7. Repeat the procedure for the Reverse Play.
Using the right reel table. 180 to 220 g·cm (2.5 to 3.1 oz-inch)

Adjustment Location

If necessary, adjust slider of the resistors until you have the correct scale reading for optimum torque. Refer to adj. location below.

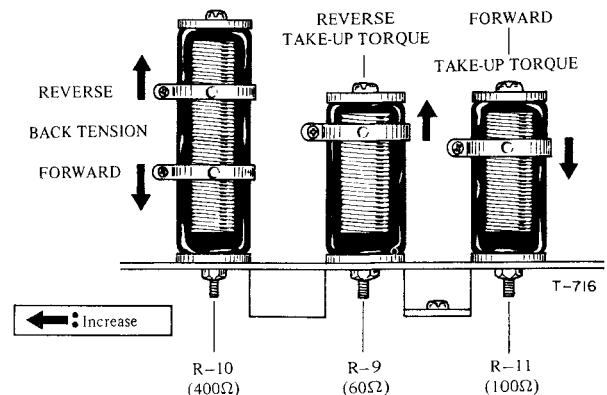

7-5 REEL HEIGHT ADJUSTMENT

Reel height adjustment is required only if a motor has been replaced or if tape rubs excessively against the reel. Adjustment is accomplished by FINE ADJ. screw in the reel turntable. Reel turntable height should be checked using standard 7" reels. With a tape threaded on the machine, position the reel height for smooth tape travel. If adjustment is necessary, remove the reel and adjust the screw. Then replace the reel and re-check the adjustment.

7-6 TAPE SPEED

The tape speed should be measured using TEAC flutter free tape, Model YTT-2003 (7-1/2 ips), YTT-2002 (3-3/4 ips). These tapes contain a highly accurate 3,000 Hz tone. Connect a digital frequency counter to either line OUTPUT jack. The indicated frequency should be 3,000 Hz \pm 30 Hz for both speeds and both directions.

7-7 WOW AND FLUTTER CHECK

NOTE: Before performing this measurement, clean the head and Tape run guides, also check pinch roller pressure, etc.

Use new Test Tape if possible for following adjustments.

Values obtained with different standards of equipment cannot be compared.

PLAYBACK

1. Connect Test equipment to the unit as shown in Fig. 7-5. (Except oscillator).
2. Load TEAC YTT-2003 (for HIGH, 7-1/2 ips) or YTT-2002 (for LOW, 3-3/4 ips) and playback tape.
3. Read the indication on the Wow and Flutter meter.
4. The Wow and Flutter should be
 - 0.18% (RMS) for 7-1/2 ips
 - 0.20% (RMS) for 3-3/4 ips

OVERALL

1. Connect Test equipment to the unit as shown in Fig. 7-5.
2. Load TEAC YTT-8003 (blank tape) Test Tape on the unit and Record a 3,000 Hz input signal.
3. Rewind and playback the recorded signal.
4. The reading on the Meter should be
 - 0.20% (RMS) for 7-1/2 ips
 - 0.25% (RMS) for 3-3/4 ips

NOTE: These figures apply to any tape position (such as full take-up reel, full supply reel or about mid-point). Also examine the tape counter ass'y for evenness of operation.

7-8 VOLTAGE AND FREQUENCY CONVERSION

This deck is adjusted to operate on an electric power source of the voltage and frequency specified on the reel tag and packing carton. If it is necessary to change the frequency or voltage requirements of this deck to match your area, use the following procedures.

Always Disconnect Power Line Cord before making these changes.

Frequency Conversion: (only Export model)

1. Remove the right side wood panel (4 screws), then the rear/top metal panel (6 screws).
2. Set the power frequency selector slide switch (located next to the capstan motor) to the 50 or 60 position to match the power line frequency in your area.
3. Rotate the center (capstan) motor clockwise with your hand and re-position the belt onto the correct pulley as shown in the Motor Pulley Illustration below. The pulley can be seen by looking through the opening in the side panel. Continue to rotate the motor by hand approximately 10 revolutions to verify belt placement before replacing the side and rear covers.

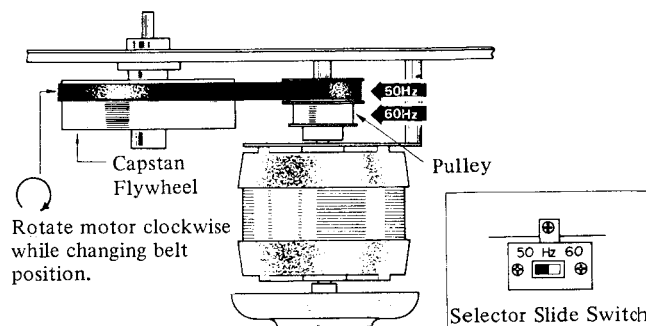

Fig. 7-6 Frequency Conversion

Voltage Conversion: (only Export model)

The deck may be set for 100, 117, 220 or 240 volts. To change the voltage unscrew the fuse in the center of the voltage selector plug. Pull out the plug and reinsert it so the desired voltage shows in the cutout. Reinstall the fuse specified on the label on the rear of the deck.

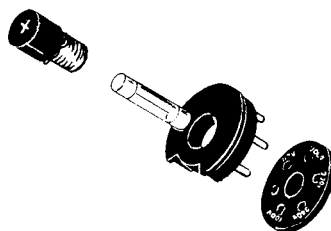

Fig. 7-7 Voltage Conversion

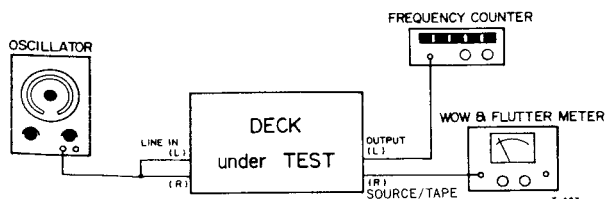

Fig. 7-5 Test Connections for Wow/Flutter and Tape Speed Test

8. MEASUREMENT AND ADJUSTMENT

—ELECTRICAL—

NOTE: Before performing maintenance on this deck, thoroughly clean and demagnetize the entire Tape path, TEAC maintenance equipment to be used:

TEAC TZ-261 A/B for cleaning

TEAC E-3 for demagnetizing or equivalents

Service Data were determined using TEAC YTT Series Test Tape.

Procedure for checks and adjustments, unless otherwise indicated, are for the left channel at a tape speed of 3-3/4 ips (9.5 cm). The same procedures are to be applied to the right channel and again for both channels at 7-1/2 ips (19 cm) speed.

The deck must be matched to the voltage and frequency of your locality.

Most amplifier checks and adjustments can be made from the bottom with the (bottom) metal panel removed.

8-1 ADJUSTMENT LOCATIONS AND ADJUSTMENT POINTS

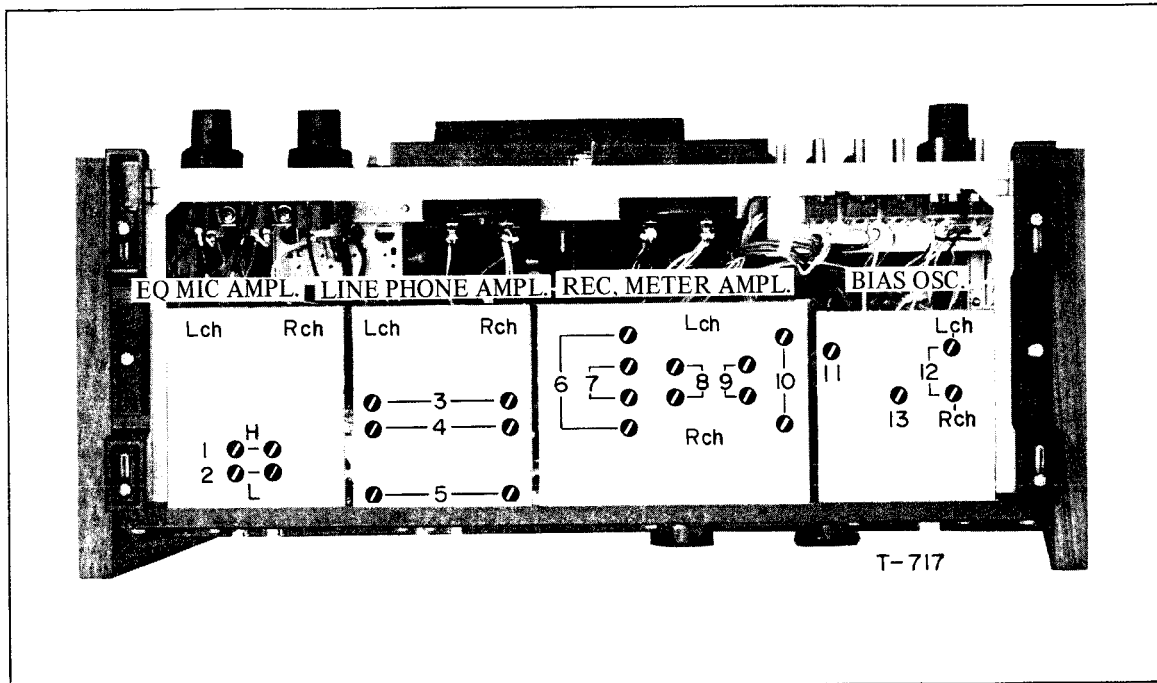

Ref. Nos Abv.	FOR	ADJUSTMENT (L/R)
1	P.B.EQ (HIGH)	VR101/103
2	P.B.EQ (LOW)	VR102/104
3	BIAS TRAP (For OUTPUT)	L201/202
4	P.B. LEVEL	VR201/203
5	P.B.METER CAL.	VR202/204
6	RECORD METER CAL.	VR302/305
7	MONITOR LEVEL	VR301/304

Ref. Nos Abv.	FOR	ADJUSTMENT (L/R)
8	RECORD LEVEL	VR303/306
9	REC EQ	L301/303
10	BIAS TRAP	L302/304
11	DUMMY COIL	L401
12	BIAS ADJ. (SW-1)	VC401/402
13	BIAS ADJ. (SW-2)	VR401 (both chan.)

Ampl PC Board Location and Adjustments Points

8-2 ADJUSTMENT SEQUENCE CHART

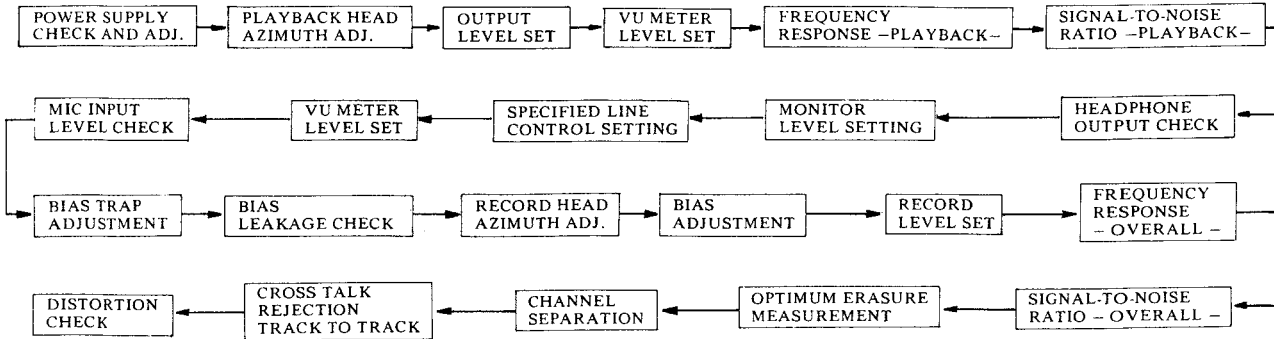

Fig. 8-1 Adjustment Sequence Chart

PLAYBACK PERFORMANCE

8-3 POWER SUPPLY CHECK AND ADJ.

1. Remove metal panel on Rear side of the deck for access to the electrical adjustments.
2. Depress power SW to ON.
3. Connect a VTVM between the Control P.C.B. Test Point No. 3 and ground. See Fig. 8-2 below.
4. Adjust VR-1 for +23 V DC.

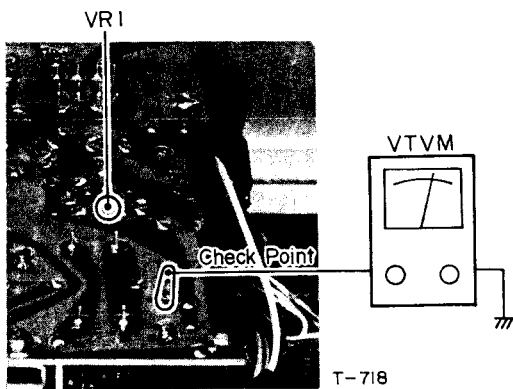

Fig. 8-2 +23 V DC Test Point

1. Connect a VTVM to OUTPUT jacks.
2. Remove the head housing by removing 2 screws.
3. Thread the TEAC YTT-1002 Test Tape on the deck.
4. Play the 16 kHz/-10 dB Test tone in section 2 of the Test Tape.
5. Slowly rotate the azimuth Screw until maximum indication is achieved on VTVM.
6. Connect an oscilloscope to the OUTPUT jacks.
7. Adjust the azimuth screw (If necessary) until the oscilloscope shows that the signals are less than 45° out of phase at 10 kHz signal.
8. Secure this screw with a drop of locking paint.
9. Depress the ◀ button and turn azimuth adjustment screw Fig. 6-3 of the reverse playback head for maximum indication on the VTVM or scope.

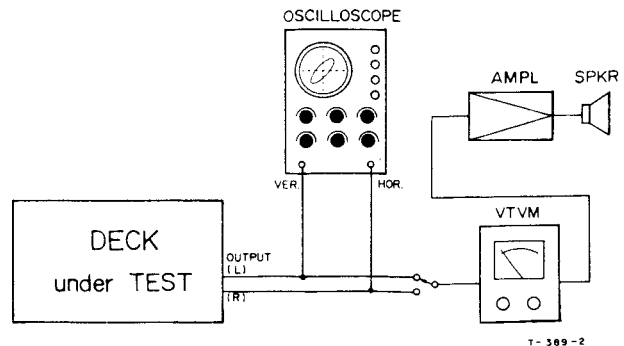

Fig. 8-3 Head Alignment Fine Adjustment Set-up and Test Connections (PLAYBACK)

8-4 PLAYBACK HEAD AZIMUTH ADJ.

NOTE: Before proceeding with the following head alignments be sure that heads have been properly mounted as to HEIGHT, TILT and TANGENCY. See page 9.

— Fine Adjustment —

TAPE SPEED SW . . . 3-3/4 ips (9.5 cm)
 OUTPUT SW TAPE
 METER SW NORMAL

8-5 OUTPUT LEVEL SETTING

– MAXIMUM OUTPUT LEVEL CHECK –

10. Play the 400 Hz/0 dB tone in section 1 of the Test Tape.
11. Turn the OUTPUT controls fully clockwise.
12. Adjust VR-201/203 for –2 dB (615 mV) at OUTPUT jacks.

– SPECIFIED OUTPUT LEVEL SETTING –

13. Reduce both OUTPUT controls together until the lower reading channel reads –8 dB. (approx. 2 o'clock position).
14. If there is a difference in level between L-ch and R-ch, again adjust VR-201/203 (whichever is higher) for –8 dB (308 mV).

NOTE: This is the Specified Output level setting. Do not disturb this setting until the remaining adjustments have been completed.

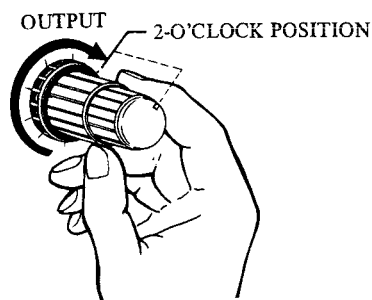

Fig. 8-4 Specified Output Level Setting

8-6 VU METER LEVEL SETTING

15. Adjust VR-202/VR-204 for 0 VU (at NORMAL scale) reading on VU Meters, Set METER SW to HIGH. 0 VU should be read on HIGH scale.

8-7 FREQUENCY RESPONSE –PLAYBACK–

16. Thread TEAC YTT-1002 on the deck.
17. Play Tape and compare reading on VTVM with the response limits given in Fig. 8-5.
18. If adjustment is required, adjust VR-101/VR-103 for 3-3/4 ips (9.5 cm) speed.
19. Change Tape SPEED SW to 7-1/2 ips (19 cm) position.
20. Thread TEAC YTT-1003 on the deck.
21. Repeat Step 17.
22. If adjustment is required, adjust VR-102/VR-104 for 7-1/2 ips (19 cm) speed.

NOTE: If the frequency response does not meet specified response limits, especially at the high-end of the spectrum, head should be checked for accumulated dirt or oxides. If clean, head azimuth must be readjusted.

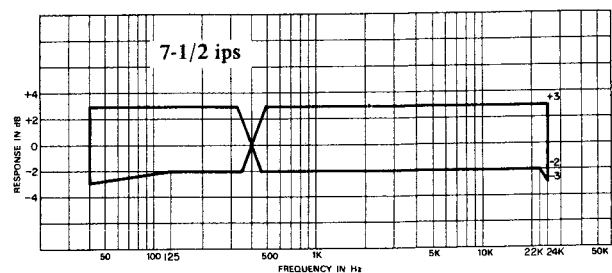
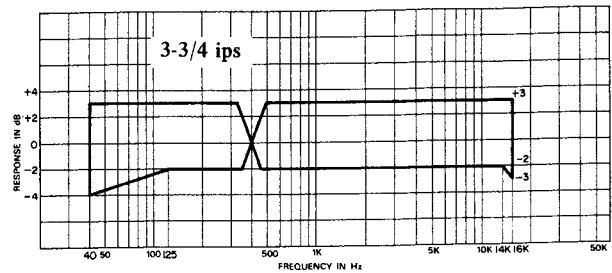

Fig. 8-5 Frequency Response – PLAYBACK –

– REVERSE PLAYBACK HEAD CHECK –

Depress ◀ (Reverse Play) button and check for suitable output from both channels. If necessary adjust Height and azimuth adj screws (See Fig. 6-3) of Reverse Playback Head for best output.

8-8 SIGNAL-TO-NOISE RATIO –PLAYBACK–

1. OUTPUT controls should be at the Specified Output level settings.
2. Thread a YTT-1003 on the unit leaving the tape outside the capstan and pinch roller.
3. Hold the play supply reel stationary and depress the play (▶) button.
4. The VTVM connected to the OUTPUT jacks should indicate readings listed below.

HIGH (7-1/2 ips)	50 dB
LOW (3-3/4 ips)	48 dB

8-9 HEADPHONE OUTPUT CHECK

1. Connect an 8 ohm non-inductive resistor across the headphone (PHONE) jack.
2. Connect VTVM across the resistor. VTVM should indicate –24 dB ± 2 dB (61 mV ~ 39 mV).

8-10 MONITOR LEVEL SETTING

OUTPUT SW SOURCE

1. Turn LINE controls fully clockwise.
2. Apply a 400 Hz -18 dB (97 mV) signal from AF oscillator to LINE IN jacks.
3. Adjust VR-301/VR-304 for -8 dB (308 mV) at the OUTPUT jacks.

8-13 MIC INPUT LEVEL CHECK

This is check only. No adjustment is to be made.

1. Decrease LINE controls to minimum position.
2. Set MIC controls fully clockwise.
3. Apply a 400 Hz signal at -70 dB (0.244 mV) to the MIC input jacks.
4. Check for -8 dB (308 mV) level at OUTPUT jacks.
5. With -8 dB (308 mV) at OUTPUT jacks, MIC input level should be -70 dB ± 2 dB (0.194 mV \sim 0.308 mV).
6. Return MIC controls fully counter clockwise to prevent noise insertion during following steps.
7. Reset the LINE controls, to the "Specified setting".

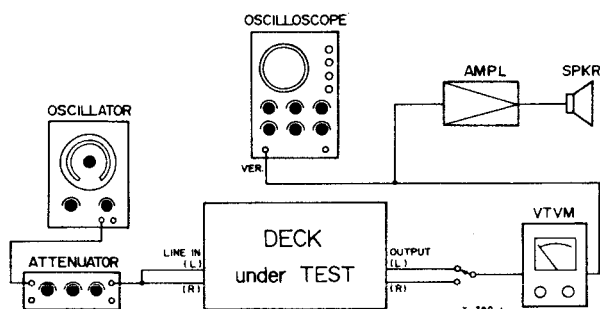

Fig. 8-7 Test Connections for Monitor Check

8-11 SPECIFIED LINE CONTROLS SETTING

4. Apply a 400 Hz -8 dB (308 mV) signal from AF oscillator to LINE IN jacks.
5. Adjust LINE controls for -8 dB (308 mV) at OUTPUT jacks.

NOTE: At this point both the line controls and OUTPUT controls are at the "Specified setting". Do not move these controls unless instructed in this procedure to do so.

The accuracy of many of the following adjustments and readings depends on these controls being at the "Specified setting".

8-12 VU METER LEVEL SET

6. Check VU Meters for 0 VU indication.
7. Adjust VR-302/VR-305 for 0 VU, if necessary.

8-14 BIAS TRAP ADJUSTMENT

OUTPUT SW TAPE
 RECORD MODE (L, R) SW ON
 BIAS and EQ SW 1
 Select REC PAUSE mode

1. Remove all input signals.
2. Connect a VTVM or oscilloscope from ground to the junction of L-302 and C-314 (L-ch) and from ground to the junction of L-304 and C-329 (R-ch). See Fig. 8-8.
3. Adjust L-302 (L-ch) and L-304 (R-ch) for minimum reading on scope or VTVM.
 Use Plastic alignment tool.

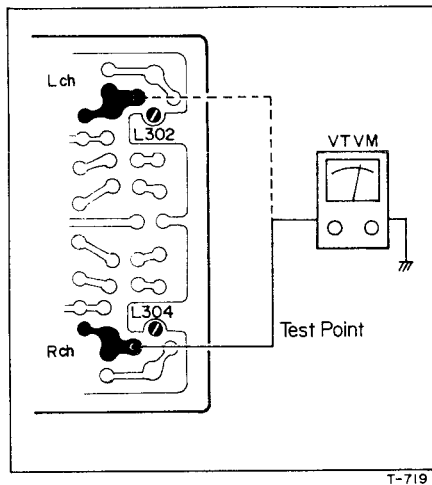

Fig. 8-8 Bias Trap Test Point

8-15 BIAS LEAKAGE CHECK

4. With Output control and Line controls at any positions Bias Leakage should be following value at OUTPUT jacks.
 Spec. -40 dB (7.75 mV).
 Check both the SOURCE and the TAPE position.

8-16 RECORD HEAD AZIMUTH ADJ.

Tape SPEED SW 3-3/4 ips (9.5 cm)

NOTE: The effect of turning the azimuth screw will register on the VTVM. A slight delay will be noticed. Therefore, the screw must be rotated slightly with a pause to see the effect.

—Fine Adjustment—

5. Connect a VTVM to the OUTPUT jack and an AF oscillator to the LINE IN jack.
 Set the oscillator to 10 kHz at -18 dB (97 mV).
6. Begin recording (Depress REC and PLAY buttons).
7. While recording, adjust the azimuth screw for maximum reading on the VTVM.

NOTE: It is absolutely essential to accomplish the above adjustment before performing the following adj. to avoid phase errors greater than 45°.

8. Sweep the oscillator frequency from 50 Hz to 10 kHz (for 7-1/2 ips), 50 Hz to 7.5 kHz (for 3-3/4 ips) and check that phase difference between channel is 45° or less.
9. Secure the screw with insulating locking paint.

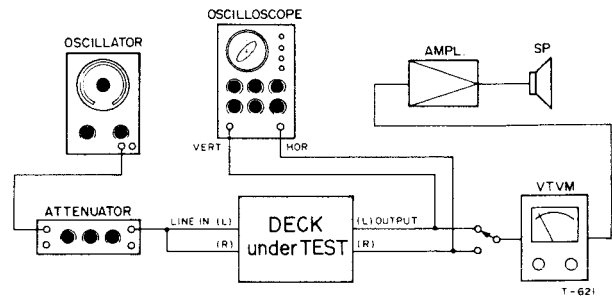

Fig. 8-9 Test Connection for Recording Check

8-17 BIAS ADJUSTMENT

Be sure the Bias Trap has been adjusted per section 8-14 before proceeding.

10. Apply 7 kHz signal at -18 dB (97 mV) to the LINE IN jacks.
11. While recording on the YTT-8003 Test Tape, adjust capacitor VC-401/VC-402 for peak reading on the VTVM, then turn the capacitor clockwise until a decrease of 2.5 dB "over-bias" from the peak is obtained.

BIAS and EQ SW 2

12. Apply 400 Hz signal at -18 dB (97 mV) to the LINE IN jacks.
13. While recording on the YTT-8023 Test Tape, adjust VR-401 (both chan.) for an Over-Bias of 0.5 dB from the peak.

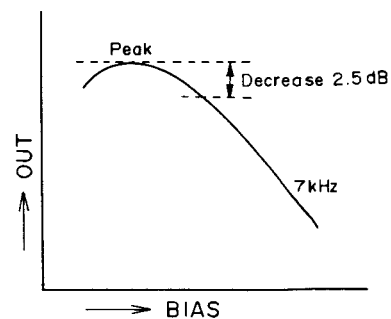

Bias Limits Chart

8-18 RECORD LEVEL SET

14. Apply 400 Hz signal at -8 dB (308 mV) to the LINE IN jacks.
Be sure the Line and Output controls are still at their previously set positions.
15. Begin recording.
16. Adjust VR-303/VR-306 for -8 dB (308 mV) at OUTPUT jacks.

8-19 FREQUENCY RESPONSE –OVERALL–

NOTE: To avoid saturation of the tape these checks should be made at least 20 dB below the specified input level.

Any Bias signal feeding into the test equipment should be filtered out by adjusting the external Bias Trap.

BIAS and EQ SW 1
Tape SPEED SW 3-3/4 ips (9.5 cm)

19. Apply signal swept from 40 Hz to 16 kHz, -28 dB (30.8 mV) to the LINE IN jacks and record on a blank TEAC YTT-8003 Test Tape.
20. During recording, monitor the Tape signal and adjust equalization L-301/L-303 for readings within the Response Limits charts. See Fig. 8-10 below.
21. Change the Tape SPEED SW to HIGH position.
22. Apply signal swept from 40 Hz to 24 kHz, -28 dB (30.8 mV) and while monitoring the off-the-Tape signal check for readings within the Response Limits charts. See Fig. 8-10 below.

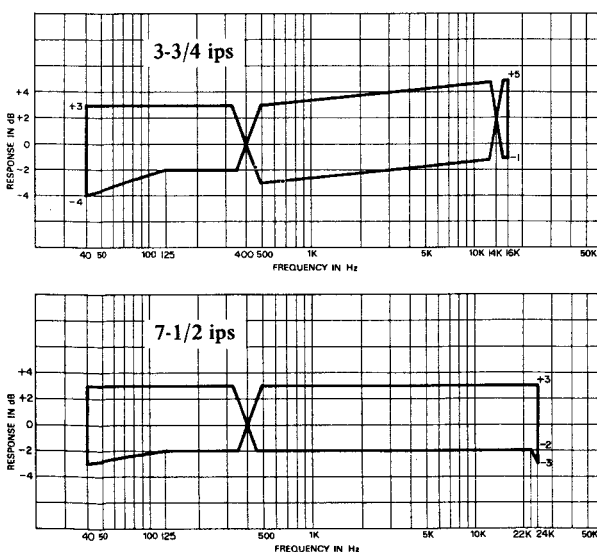

Fig. 8-10 Frequency Response – OVERALL – 1

BIAS and EQ SW 2

23. Apply signals swept from 40 Hz to 14 kHz to the unit while recording on a blank TEAC YTT-8023 Test Tape.
24. Repeat the above procedure for HIGH, using a signal swept from 40 Hz to 22 kHz. Refer to Response Limits in Fig. 8-11 below.

NOTE: If the response is not uniform, the head should be cleaned of accumulated oxide and dirt. Then repeat the Bias adjustment procedure by VR-401 (both channel).

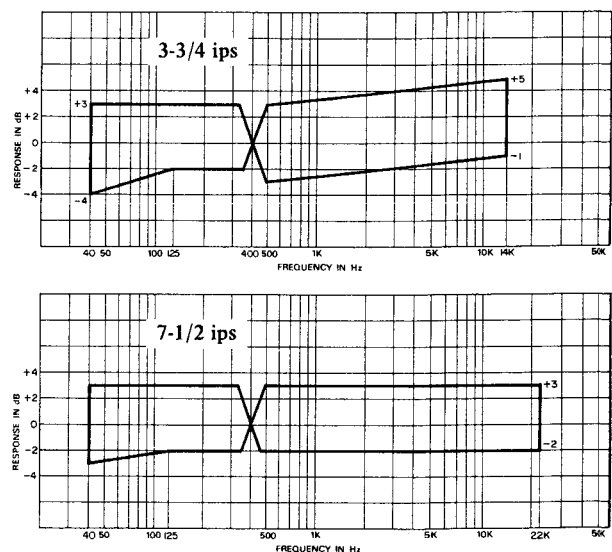

Fig. 8-11 Frequency Response – OVERALL – 2

8-20 SIGNAL-TO-NOISE RATIO –OVERALL–

1. Output and Line controls should be at the specified positions.
2. Remove the AF oscillator from the LINE IN jacks.
3. Place the deck in the Record mode with “no signal” applied. Note the point on the index counter where recording begins.
4. Rewind the tape (YTT-8003) to the beginning point and play it back.
5. The noise level as indicated on the VTVM should be readings listed below.

HIGH (7-1/2 ips) -56 dB
LOW (3-3/4 ips) -54 dB

6. This -56 dB/ -54 dB corresponds to the Signal-To-Noise Ratio of 48 dB/46 dB (minimum): the difference between residual noise of -56 dB/ -54 dB and the specified output level -8 dB. -8 dB reference level is also applicable following measurements.

8-21 OPTIMUM ERASURE MEASUREMENT

Tape SPEED SW 7-1/2 ips (19 cm)

1. Thread the TEAC YTT-8003 Test Tape on the unit.
2. Apply a 1 kHz signal at 10 dB above the operating level of -8 dB (975 mV) to the LINE IN jack.
3. Make a 30 seconds recording of the above signal while reading and noting the level of output, then rewind to beginning of this recording.
4. Disconnect the 1 kHz signal source (AF oscillator) from the LINE IN jack.
5. Connect a VTVM to the OUTPUT jack, through a 1 kHz Narrow Band Pass Filter.
6. Put deck in the Record mode and "record" (erase) over this previous recording, then rewind to beginning again.
7. Put deck in Play mode and monitor the output on the VTVM.
8. Difference in output level, between the 1 kHz signal and the "no signal" section level should be more than 68 dB.

NOTE: Filter loss should be considered.

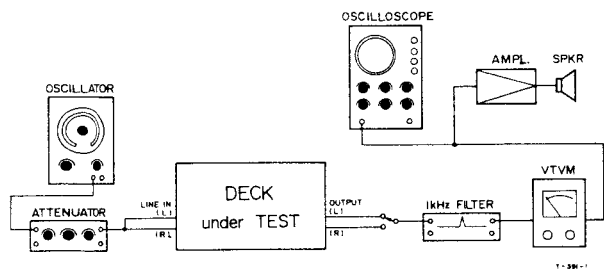

Fig. 8-12 Test Connections for Erase measurement

8-22 CHANNEL SEPARATION

1. Be sure tape is completely bulk erased prior to doing these checks.
2. Apply a 1 kHz signal at -8 dB (308 mV) to L chan.
3. Place deck in Record mode.
4. While recording measure the OUTPUT on R chan. VTVM connected through a 1 kHz Band Pass Filter. Spec. should be 50 dB.

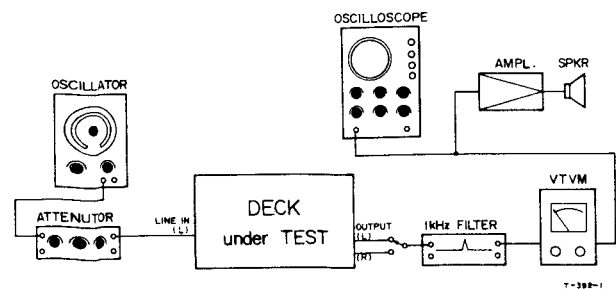

Fig. 8-13 Test Connections for Channel separation check

8-23 CROSS TALK REJECTION (TRACK TO TRACK)

Following is the measurement procedure at 7-1/2 ips using the TEAC standard tape, Type YTT-8023:

1. Thread a blank tape or the YTT-8023 tape on the unit.
2. Apply a 125 Hz signal at -8 dB (308 mV) to the right and left channel LINE IN jack.
3. Make a 30 second recording of the 125 Hz signal.
4. Interchange the left and right reels and rethread tape on the unit.
5. Connect a VTVM to the right channel OUTPUT jack.
6. Playback the recorded signal portion of tape and monitor the level on the VTVM.
7. The reading should be 4 8 dB.
8. Spec. should be 40 dB.

8-25 DISTORTION CHECK

Tape SPEED SW 7-1/2 ips (19 cm)
BIAS and EQ SW 1

9. Thread the TEAC YTT-8003 Test Tape on the unit.
10. Apply a 1 kHz signal to LINE IN jacks.
11. Place the deck in the record mode for about 10 seconds. Rewind and play this recorded section of the tape.
12. Read the indicated value on the distortion analyzer.
13. The distortion factor should be 1.5 %.

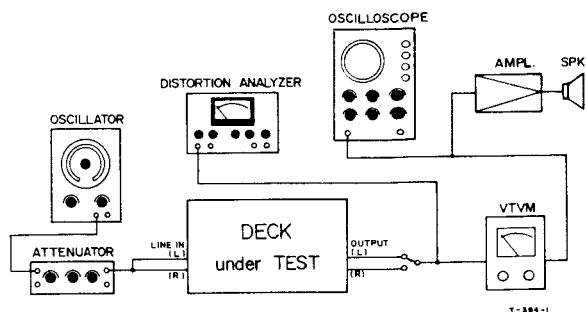

Fig. 8-14 Test Connections for Distortion check

9. TROUBLE-SHOOTING-1

NOTE: The following guide lists specific difficulties that could occur in the A-4300SX. Possible causes are listed for each malfunction. Visually inspect the unit for any damage such as broken or burned components or wiring, loose connections, etc.

MECHANICAL

MALFUNCTION	POSSIBLE SOURCE OF TROUBLE
• Fuse burns out (blows) when power applied	→ Faulty C6, D3 or D4
• Capstan motor fails to rotate when Tension Arm is raised	→ SW2 or motor defective → Drive belt off or slipping
• Transport inoperative in Forward Playback or Fast Forward	→ Remote Control dummy plug missing or loose → Faulty K4 or associated parts
• Either reel motor inoperative in playback but OK in Fast Forward	→ Defective tap on wirewound Resistor → Shorted motor capacitor or wiring → Associated circuit parts
• Both reel motors operate with high torque in Fast Forward mode	→ Defective CR16, CR17
• Excessive Crosstalk	→ Head alignment improper → Faulty K8 or associated parts
• Counter Repeat operation faulty	→ Defective Counter SW-10 to SW-11, K3, K7
• Auto Reverse sensing inoperative	→ Faulty K6, Q5, Q6 or associated parts
• Reverse mode inoperative	→ Faulty K3, K5 or associated parts
• Wow-Flutter excessive (irregular tape movement)	→ Improper pinch roller pressure → Oily or defective belt → Back tension too high
• Pinch Roller fails to engage completely	→ Faulty solenoid → Defective Q3, Q4, K8 or associated parts

9. TROUBLE-SHOOTING-2

NOTE: Reference numbers given for the Amplifier section are Left channel designations. Refer to the schematic diagrams Right, for channel reference numbers.

Prefix letters indicate:

C: Capacitor	D: Diode
Q: Transistor	CR: Spark Killer (Cap.)
K: Relay	SW: Switch

ELECTRICAL

MALFUNCTION	POSSIBLE SOURCE OF TROUBLE
● Amplifier inoperative	Defective Q1, Q2 or associated parts
● Playback audio intermittent or absent	
a) If SOURCE Monitor function normal	Play head plug loose or disconnected Q101, Q102, Q103 or associated parts
b) If SOURCE Monitor function inoperative	Grounding strap loose or disconnected from the power amplifier PC Board Faulty Q201, Q202 or the associated parts
● VU Meter inoperative in TAPE MONITOR mode (OUTPUT Switch at SOURCE)	Defective monitor switch Q203 or associated parts
● VU Meter inoperative in SOURCE monitor mode (OUTPUT Switch at TAPE)	Defective monitor switch Q309 or associated parts
● VU Meter inoperative in both modes	Faulty meter or wiring
● Will not record and RECORD Indicator lamp illuminates	
a) No erase action	Faulty Q401, Q401, Q402 or associated parts
b) VU Meter SOURCE monitor function normal	Dirty Record head Defective Q301 or associated parts
● Will not record and RECORD Indicator lamp does not illuminate	RECORD-MODE switch Faulty K401

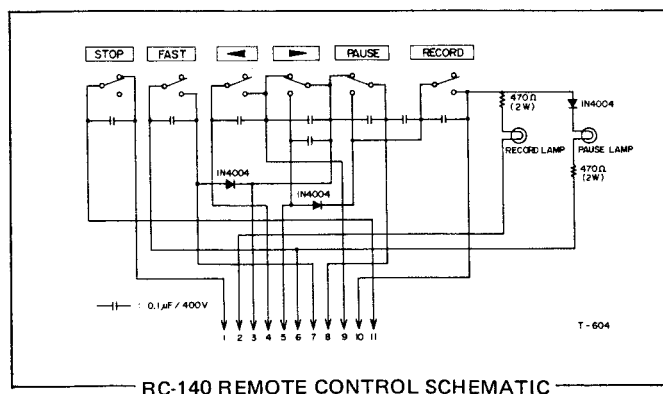

10. SERVICING AND MAINTENANCE

10-1 CLEANING:

TEAC TZ-261A for Head cleaning and TZ-161B for Rubber cleaning should be used. Use for following places.

TZ-261A	TZ-261B
Pinch roller rubber	Motor pulley
Capstan belt	Heads, Brake drums
Counter belt	Capstan shaft
	Tape run guides

10-2 LUBRICATION:

Under normal operating conditions, lubrication is required only once each year. Before lubricating, clean the drive belt and drive pulley... etc. Operate the deck for 30 minutes to 1 hour immediately prior to oiling. After oiling, keep the deck in the upright position for 3 to 4 hours to allow thorough absorption of the oil.

Approximately once each year or after 2000 hours of use, apply TEAC TZ-255 Lubricating Oil to the following places only;

- Pinch roller shaft 1 drop
- Capstan shaft 2 drops
(Remove the dust cap for access to the oil pit)
- Capstan motor 0.5 cc
(Maximum to fill oiling tube)

NOTE: Apply 3 or 4 drops at a time through the oiling tube. The oil level can be seen to drop as the felt material in the motor bearings absorb oil. When the level ceases to drop, no more oil is needed. Do not attempt to force oil into the motor nor exceed the maximum.

Excessive oiling will scatter oil inside the deck. This oil will cause drive belt slippage and other difficulties. Check for slippage and clean all parts inside the deck before operating after lubrication. Check for oil emission after operation and before returning deck to the customer.

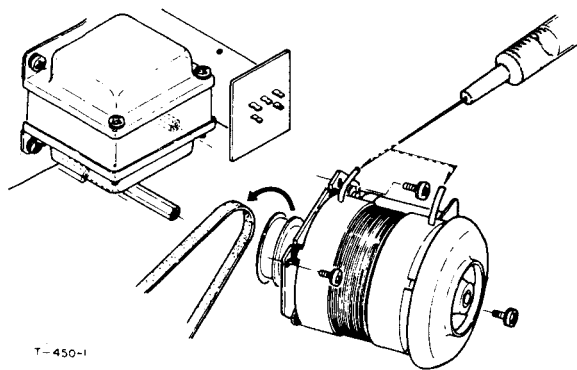

Fig. 10-1 Capstan Motor Oiling Point

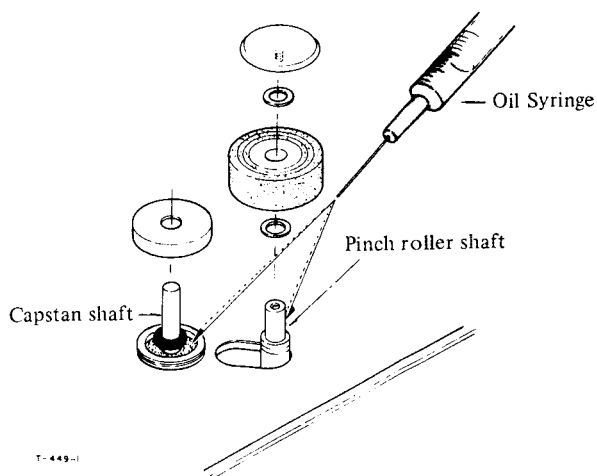

Fig. 10-2 Capstan Shaft and Pinch Roller Shaft Oiling Points

10-3 TEAC MAINTENANCE FLUIDS



Fig. 10-3 TZ-255 Oil kit



Fig. 10-3 TZ-261 Tape Recorder Kit

10-4 DEMAGNETIZATION OF HEADS

If the record or Playback heads becomes magnetized, noise will increase and tonal fidelity will deteriorate. For this reason it is advisable to use non-magnetic tools when working near the heads. If the heads have had any contact with current or magnetized metal parts, demagnetize them with a TEAC E-3 eraser or Equivalent.

11. SIMPLIFIED SCHEMATIC with level indications

PLAYBACK

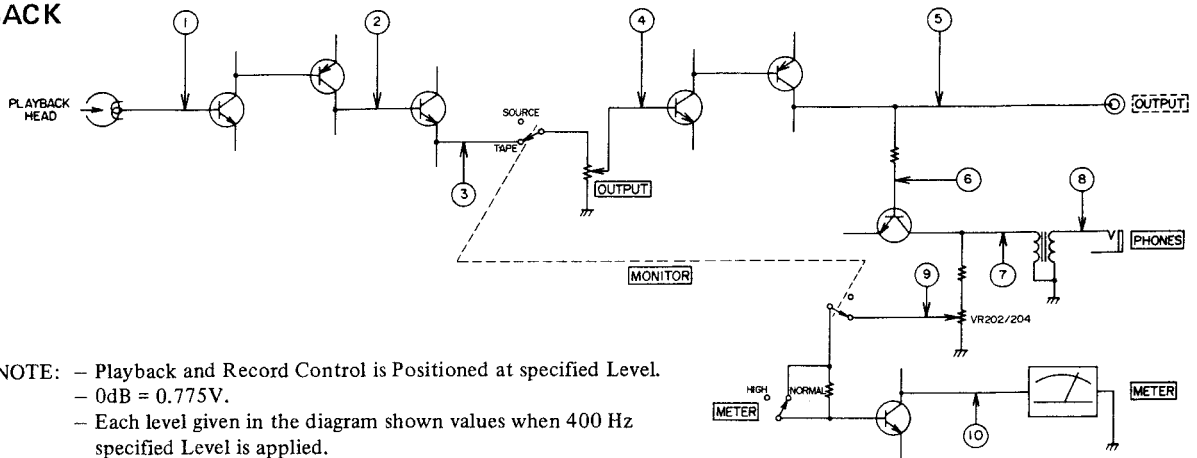

NOTE: - Playback and Record Control is Positioned at specified Level.
 - 0dB = 0.775V.
 - Each level given in the diagram shown values when 400 Hz specified Level is applied.

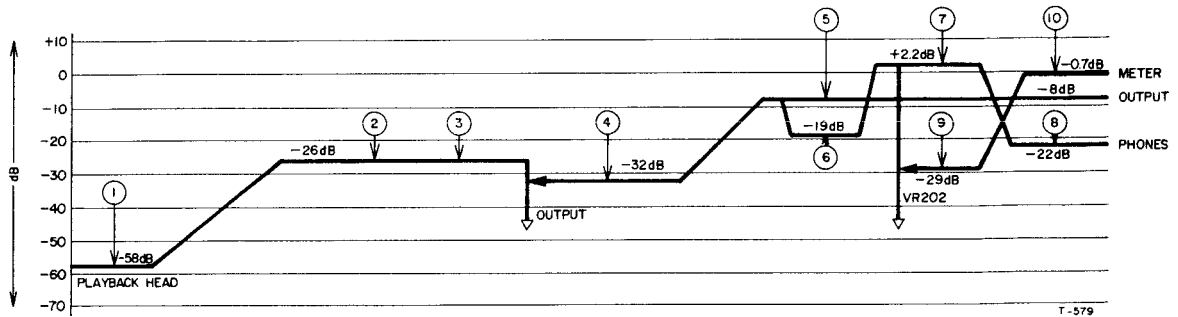

OVERALL

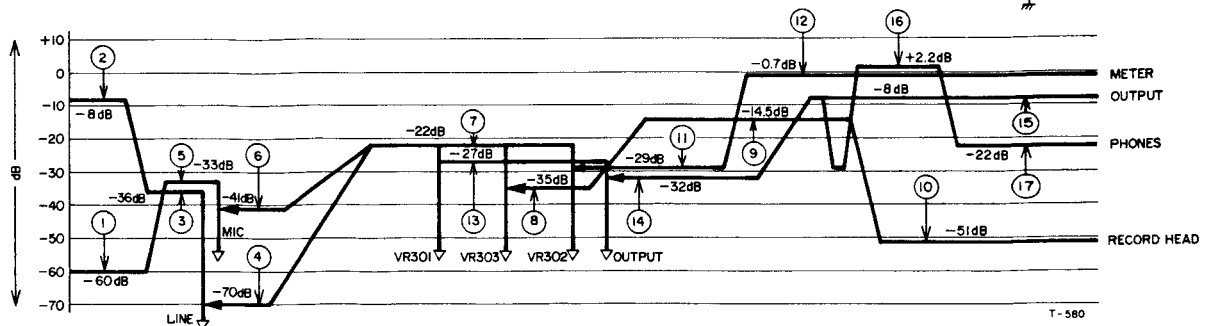
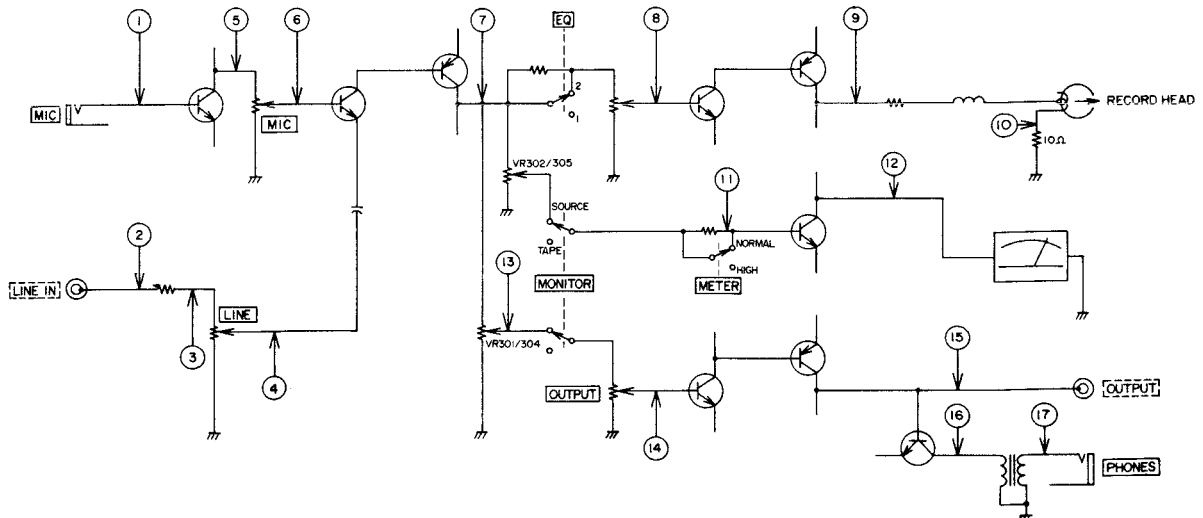

A-4300SX Stereo Tape Deck

TEAC

TEAC CORPORATION

3-7-3, NAKA-CHO, MUSASHINO, TOKYO PHONE: (0422) 53-1111

TEAC CORPORATION OF AMERICA

7733 TELEGRAPH ROAD, MONTEBELLO, CALIFORNIA 90640 PHONE: (213) 726-0303

TEAC HONGKONG LIMITED

FLAT 78, PORTLAND HOUSE, 7TH FLOOR, BLOCK C, No. 41-D, MA TAU WEI ROAD,
KOWLOON, HONGKONG PHONE: 3-659071-4

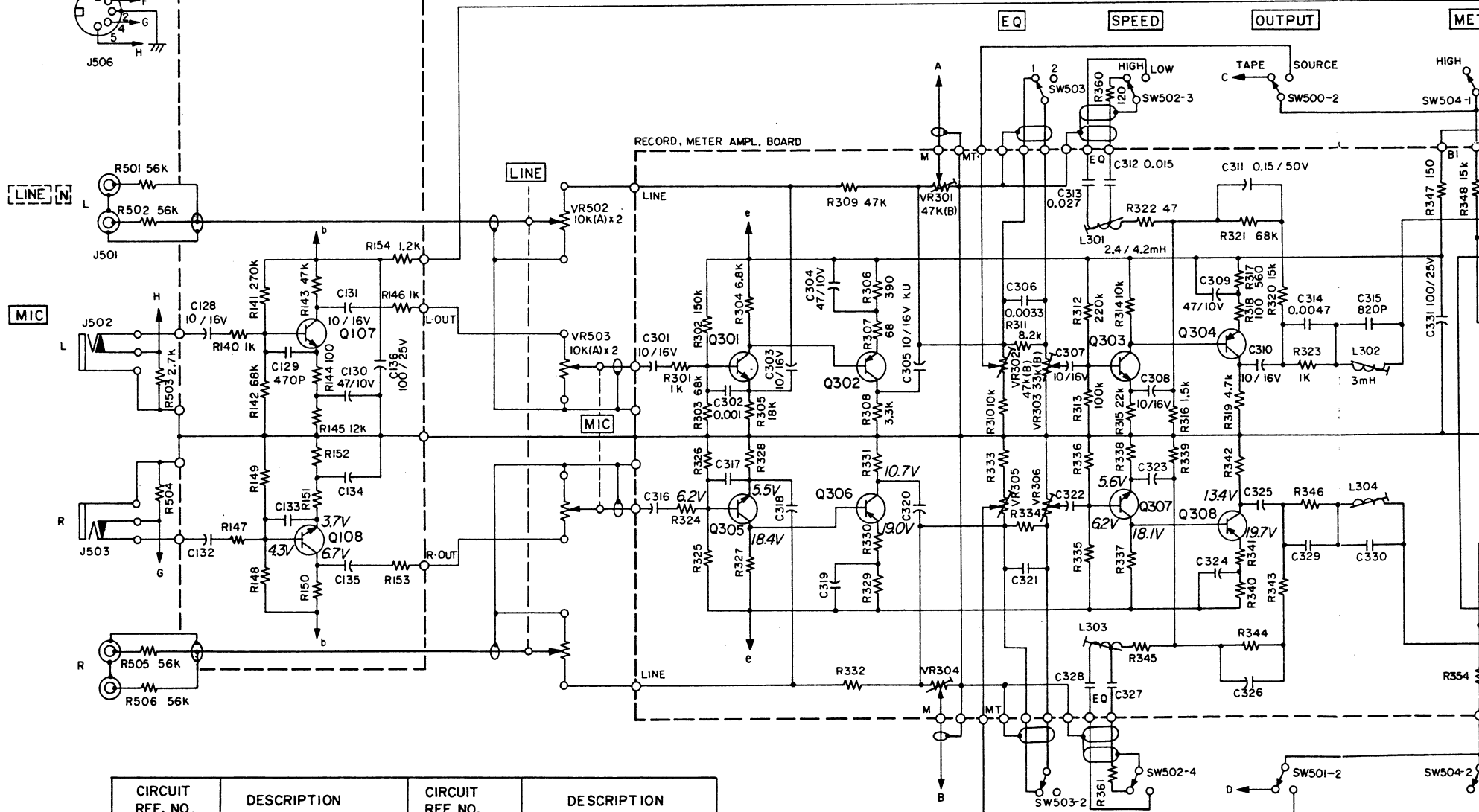
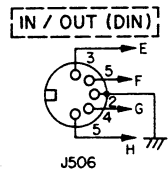
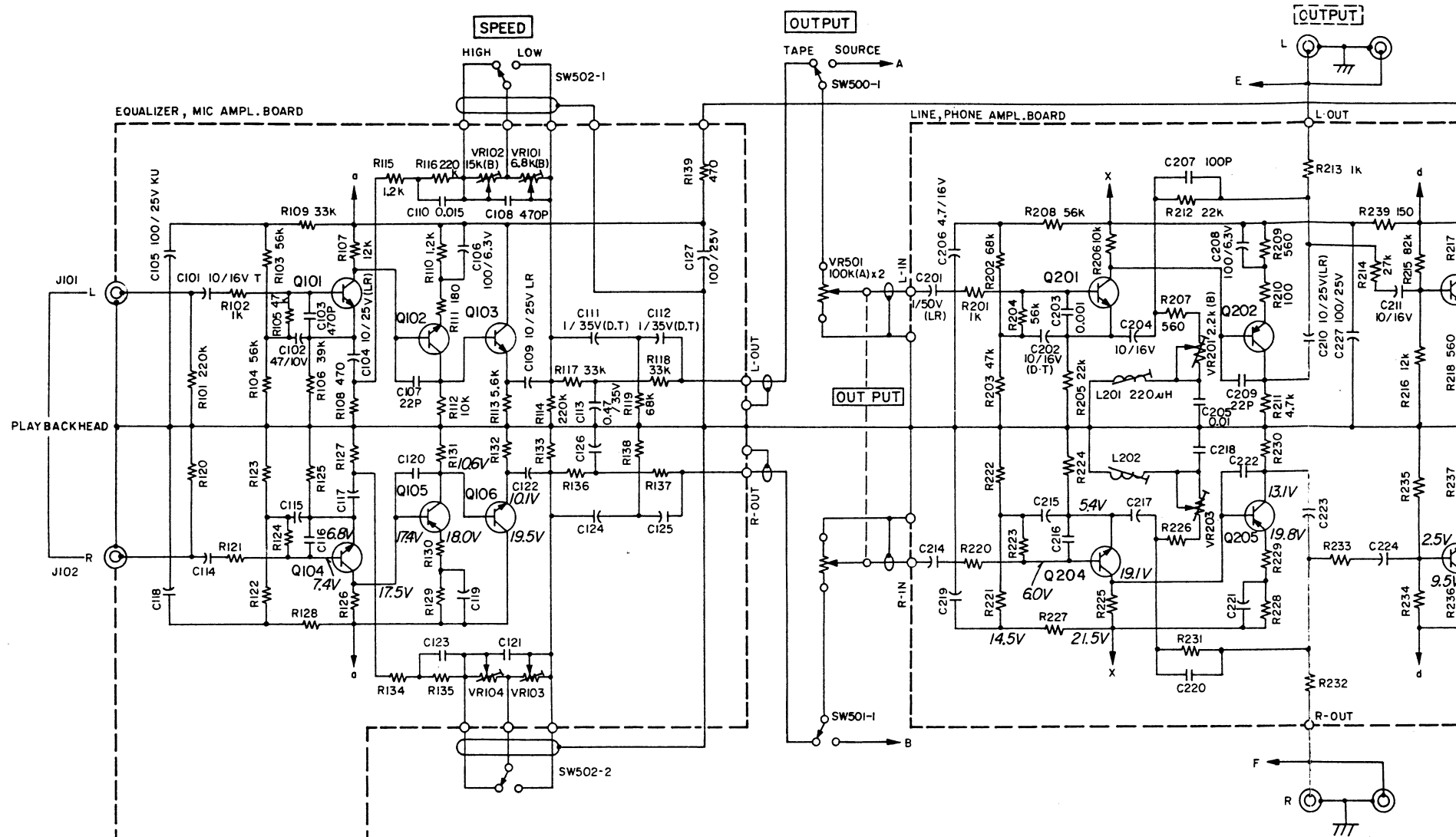

CIRCUIT REF. NO.	DESCRIPTION	CIRCUIT REF. NO.	DESCRIPTION
Q101 / 104	2SC1327 (T). 2SC1345 (E)	Q301 / 305	2SC644 (T). 2SC900 (E)
Q102 / 105	2SA763YL (5). 2SA750 (E)	Q302 / 306	2SA763YL (5). 2SA750 (E)
Q103 / 106	2SC828 (S). 2SC536 (G)	Q303 / 307	2SC644 (T). 2SC900 (E)
Q107 / 108	2SC1327 (T). 2SC1345 (E)	Q304 / 308	2SA763YL (5). 2SC536 (G)
Q201 / 204	2SC644 (T). 2SC900 (E)	Q309 / 310	2SC828 (S). 2SC536 (G)
Q202 / 205	2SA763YL (5). 2SA750 (E)		
Q203 / 206	2SC828 (S). 2SC536 (G)	Q401 / 402	2SC1384 (Q)

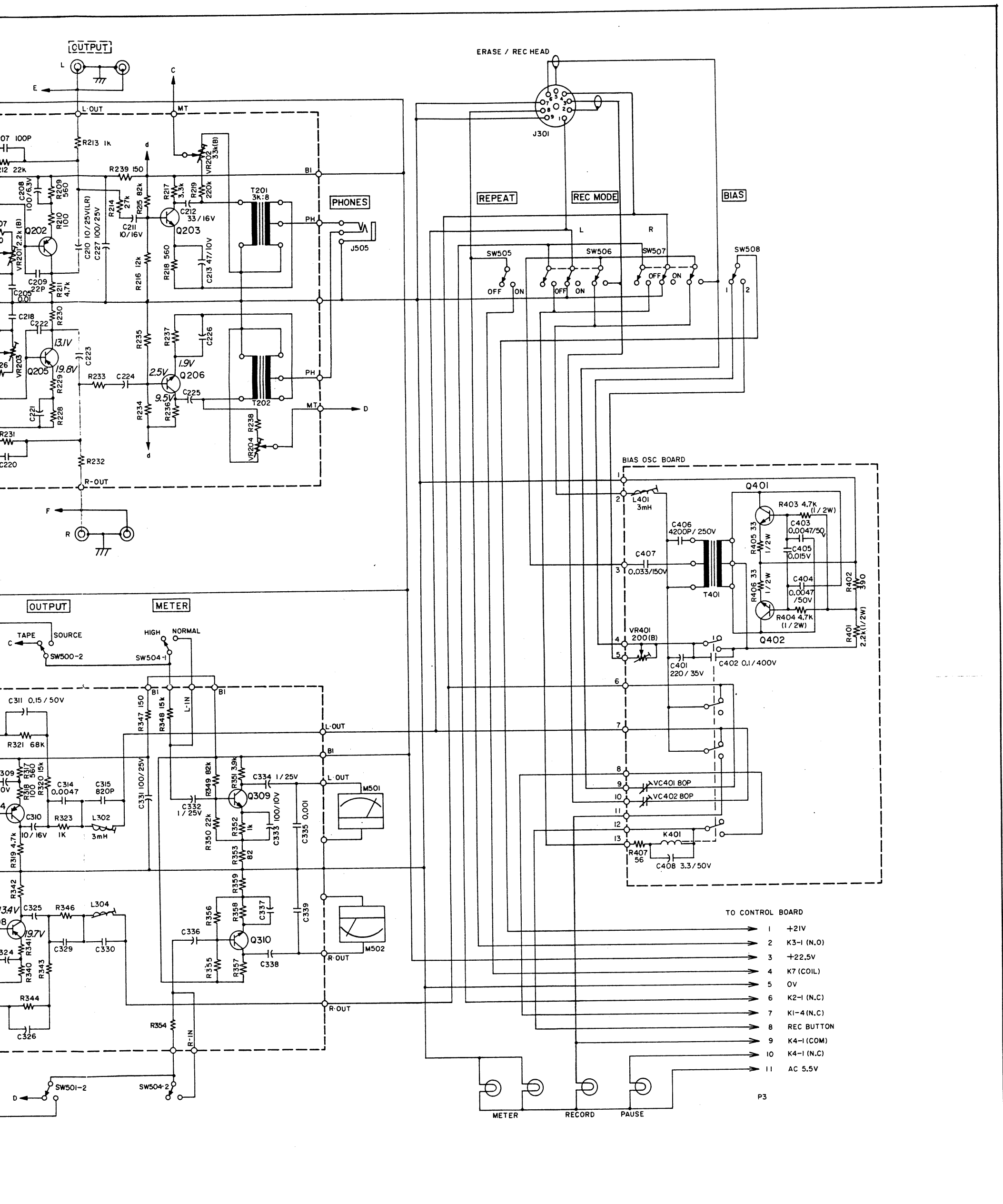

NOTES

1. ALL RESISTORS ARE 1/4 WATT, 5%. UNLESS MARKED OTHERWISE. RESISTOR VALUES ARE IN OHMS (k=1,000 OHMS, M=1,000,000 OHMS).
2. ALL CAPACITOR VALUES ARE IN MICROFARADS (p=PICOFARADS).
3. DC VOLTAGES WERE MEASURED DURING RECORD PAUSE MODE.

S - 101

6			
5			
4			
3			
2			
1	06-76		

REVISION DATE CHANGE NO.

PREAMPLIFIER
 MODEL NO. **A-4300SX** SHEET NO.
TEAC CORPORATION

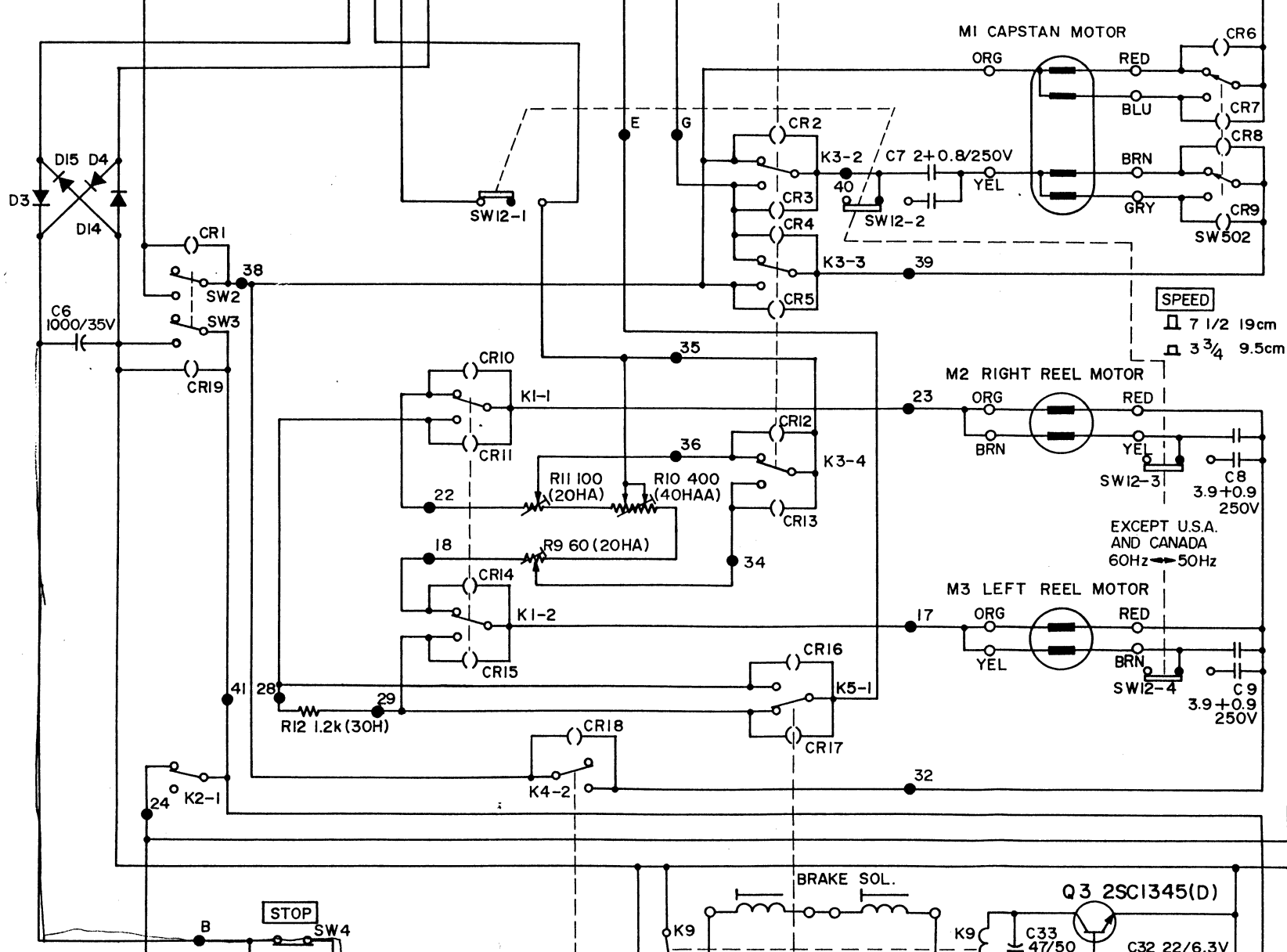
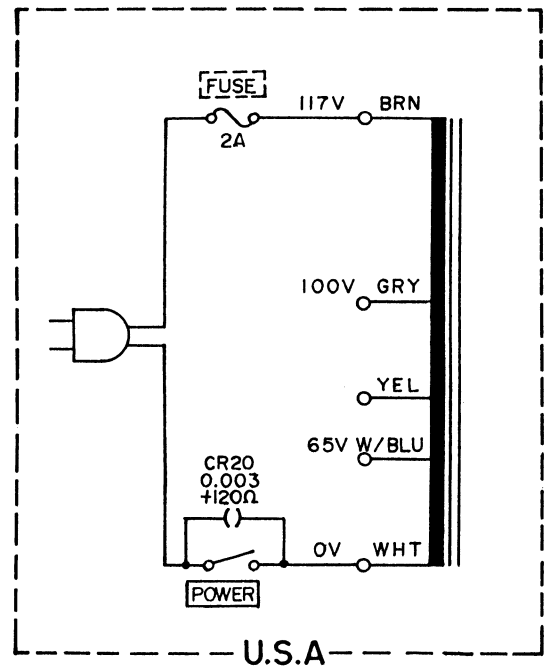
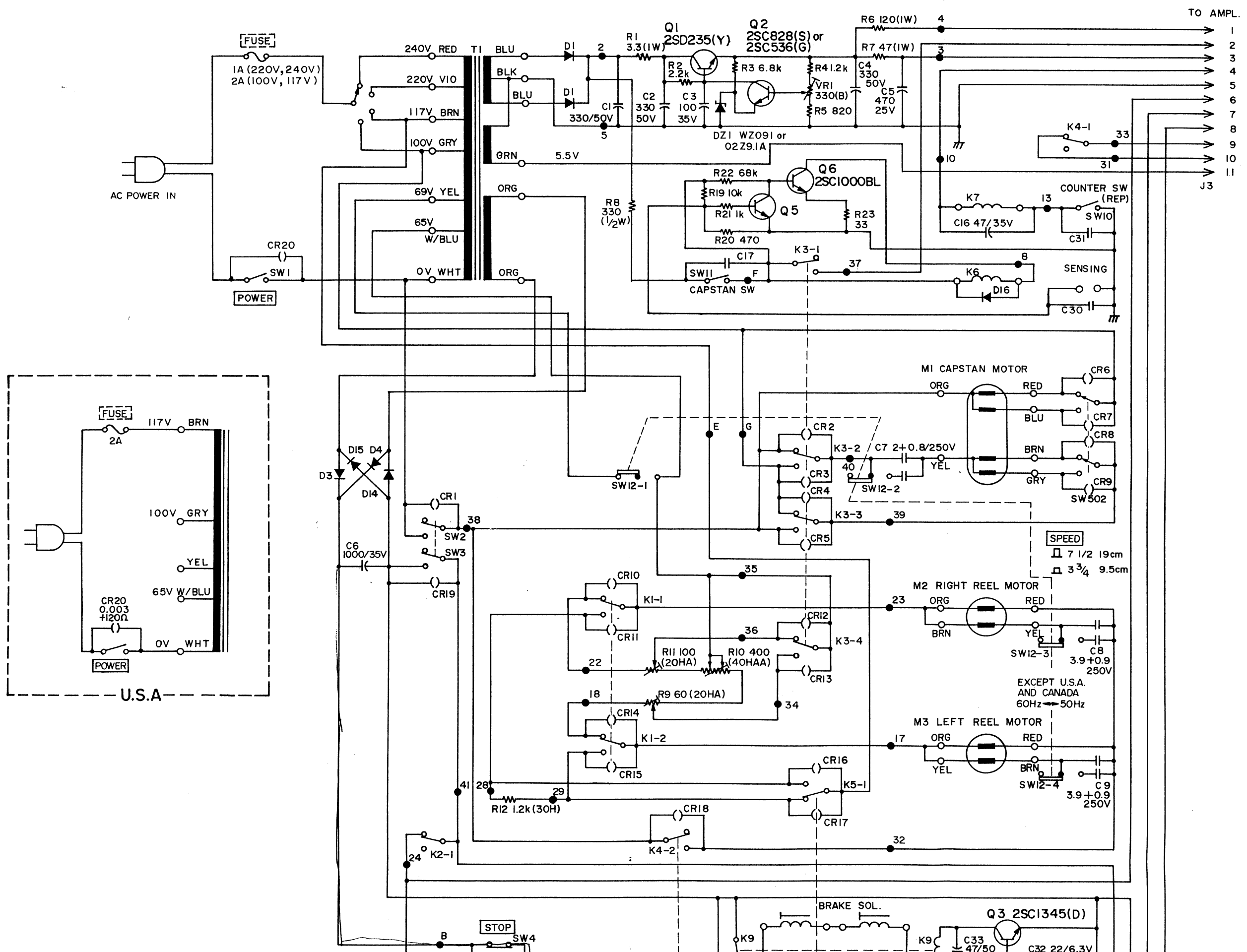

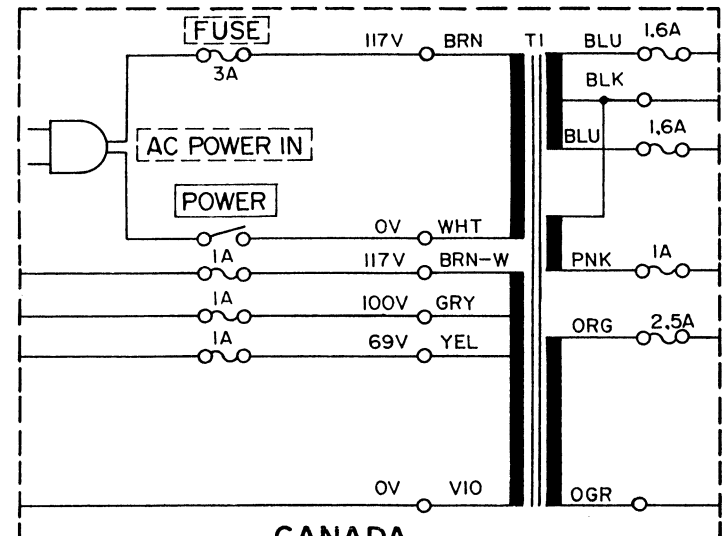
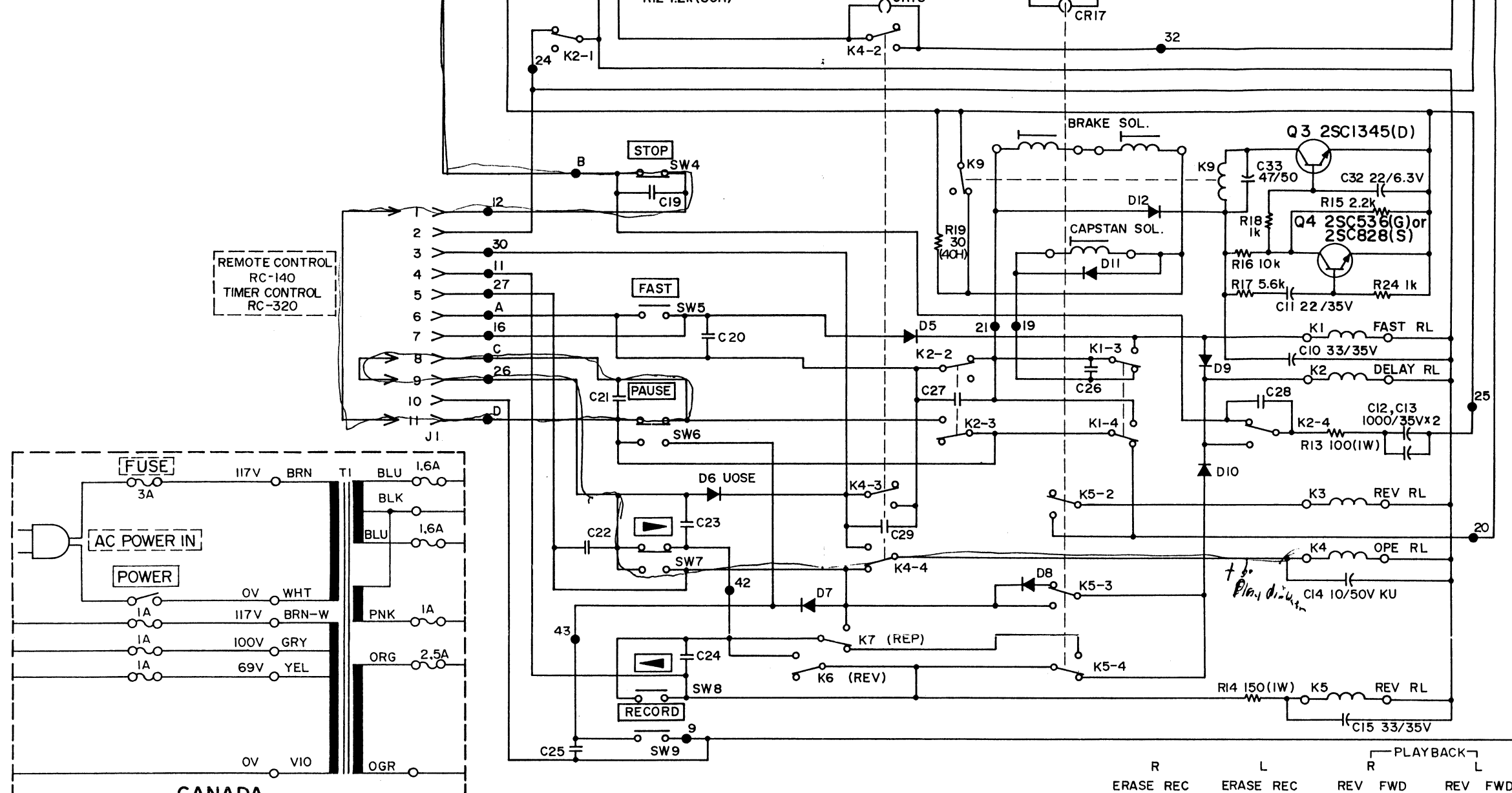

- NOTES
1. [] ON FRONT PANEL
 2. [] ON REAR PANEL
 3. D1~D5, D7~D9, D12~D16 : S1B01-02
 4. D6 : U05E
 5. D11 : S1B01-06
 6. R2~R5, R15~R17 : 1/4W
 7. C17~C31 : 0.1/400V
 8. CR1~CR20 : 0.1+120Ω/400V
 9. —○— CONTROL BOARD NO.

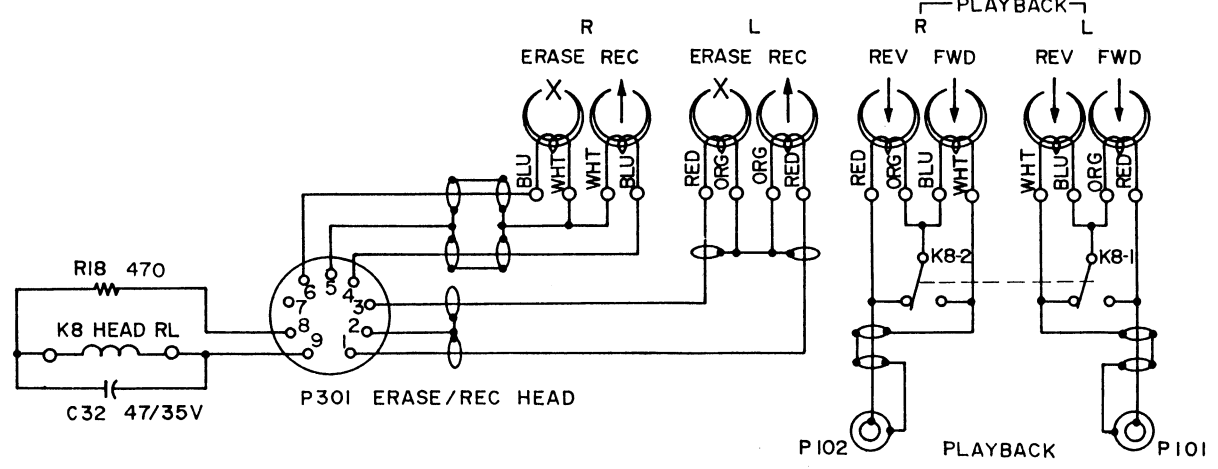

- NOTES
1. ALL RESISTORS ARE 1/4 WATT, 5%. UNLESS MARKED OTHERWISE. RESISTOR VALUES ARE IN OHMS (k=1,000 OHMS, M=1,000,000 OHMS).
 2. ALL CAPACITOR VALUES ARE IN MICROFARADS (p=PICOFARADS).

REVISION	DATE	CHANGE NO.
6		
5		
4		
3		
2	07-76	
1	06-76	

S-102

TAPE TRANSPORT

MODEL NO. _____ SHEET NO. _____

A-4300SX

TEAC CORPORATION

TEAC®

PARTS LIST

A-4300SX

Stereo Tape Deck



TABLE OF CONTENTS

1. EXPLODED VIEWS AND PARTS LIST	2~10
2. PC BOARD SECTION	
1. EQUALIZER, MIC AMPL.	11, 15
2. LINE, PHONE AMPL.	11, 15
3. RECORD, METER AMPL.	12, 16
4. BIAS OSC PC BOARD	12, 17
5. CONTROL PC BOARD	13, 17
6. RECTIFIER PC BOARD	14, 18
7. REC MUTE PC BOARD (JAPAN)	14, 18
8. TIMER PC BOARD (JAPAN)	14, 18
INCLUDED ACCESSORIES	10
ASSEMBLING HARDWARE CODING LIST	19

PARTS ORDERING INFORMATION

Spare parts are available through your nearest TEAC Authorized Service Center or directly from the TEAC office, the address of which is written on the back cover. When ordering parts, always include the following information:

- | | |
|--------------|--------------------|
| 1. MODEL | 4. DESCRIPTION |
| 2. REF. NO. | 5. UNIT SERIAL NO. |
| 3. PARTS NO. | 6. MANUAL CODE NO. |

NOTICE REGARDING PARTS ORDERS

1. Do not order by only REF. NO.
2. In some instances, individual minor parts are not available. In such a case, the entire assembly including the part requested will be sent to you.
3. Parts are identical between the different models with the exceptions as coded by the designations in the REMARKS column.
4. PC Boards shown viewed from foil side.
5. Parts marked with *require longer delivery time than regular parts.

TEAC CORPORATION

PARTS LIST-1

REF. NO.	PARTS NO.	DESCRIPTION	REMARKS
1 - 1	50112980	Grille Assy, Top	
1 - 2	55400830	Board, Side	JAPAN
	55430090	Board, Side	All except JAPAN
1 - 3	50276931	Washer, Trim	JAPAN
	55342780	Washer, Trim	All except JAPAN
1 - 4	* 55501051	Chassis Assy, Side; R	
1 - 5	* 55501041	Chassis Assy, Side; L	
1 - 6	* 55501360	Panel, Trim	
1 - 7	* 55501372	Panel, Chassis	
1 - 8	* 55501202	Cover, Rear	
1 - 9	* 55043360	Cover Assy Bottom	
1 - 10	* 50235312	Angle, Rear Cover	
1 - 11	55547380	Name Plate A-4300SX	
1 - 12	50136751	Head Housing	
1 - 13	55000752	Reel Table Assy	
1 - 14	55000720	Tension Arm Assy, Right	
1 - 15	55300831	Bushing, Arm Assy	
1 - 16	55203110	Spring, Right Tension	
1 - 17	50183921	Drum, Tension Arm	
1 - 18	50182731	Limit Stop, Tension Arm	
1 - 19	50529050	Spark Killer, 0.1 mfd + 120 ohm 400 VAC	
1 - 20	51300010	Switch, Micro	
1 - 21	* 50183932	Sheet, Insulator Paper	
1 - 22	50142180	Cap, Pinch Roller	
1 - 23	50141751	Pinch Roller	
1 - 24	55400810	Cap, Dust; 6 ϕ	
1 - 25	55000712	Guide Assy, Sensing	
1 - 26	50549920	Capacitor Metalized Mylar 0.1 mfd 400 VAC	
1 - 27	55040831	Tension Arm Assy, Left	JAPAN
	55000720	Tension Arm Assy, Left	All except JAPAN
1 - 28	50276990	Collar, Rubber	
1 - 29	50182750	Travel Limiter, Tension Arm	
1 - 30	* 50221110	Spring, B	
1 - 31	* 55330190	Leg, Case; Left	
1 - 32	* 55330180	Leg, Case; Right	
1 - 33	* 55501331	Plate, Housing Base	
1 - 34	* 55501351	Plate, Head Base	
1 - 35	55201820	Spring, D	
1 - 36	50220500	Spring, B	
1 - 37	50134371	Plate, E.R.P Head	
1 - 38	55501511	Spacer, Head; A	
1 - 39	50136540	Spacer, Erase Head	
1 - 40	50663090	Erase Head	
1 - 41	50664540	Record Head	
1 - 42	50664550	Playback Head	
1 - 43	50133891	Head Shield, A	
1 - 44	* 51683630	PC Board Assy, Head	
	50554520	Capacitor, Elec.; 47 mfd 35V	Part of above ass'y
1 - 45	50611210	Relay, Head Selector	
1 - 46	50182672	Guide, Tape	
1 - 47	* 55501340	Bracket, Protector	
1 - 48	55810430	Screw, Sideboard	All except JAPAN

PARTS LIST-2

REF. NO.	PARTS NO.	DESCRIPTION	REMARKS
2 - 1	50173560	Drum, Brake	
2 - 2	55000771	Band Assy, Brake; R	
2 - 3	55000761	Band Assy, Brake; L	
2 - 4	50171382	Felt, Brake	
2 - 5	* 50170150	Plate, Band Pressure	
2 - 6	* 50170160	Brake, Band	
2 - 7	* 55501080	Plate, Reel Motor; R	
2 - 8	* 55501070	Plate, Reel Motor; L	
2 - 9	* 50172550	Retainer, Brake	
2 - 10	71041110	Motor, Reel	JAPAN
	71041043	Motor, Reel	All except JAPAN
2 - 11	50616770	Solenoid, Brake	
2 - 12	* 50563393	Transformer, Power	JAPAN
	* 50563380	Transformer, Power	GENERAL EXPORT
	* 50562553	Transformer, Power	U.S.A., CANADA
2 - 13	* 55040960	Plate Assy, Transformer	JAPAN
	* 55501390	Plate, Transformer	GENERAL EXPORT
2 - 14	* 55501400	Plate, Resistor	
2 - 15	50524382	Resistor, Wire Wound; 400 ohm 40 HAA	
2 - 16	50522200	Resistor, Wire Wound; 60 ohm 20 HA	
2 - 17	50524201	Resistor, Wire Wound; 100 ohm 20 HA	
2 - 18	* 51700150	Capacitor, MP; (7 + 1.5) mfd	JAPAN
	* 50545940	Capacitor, MP; (3.9 + 0.9) mfd	All except JAPAN
2 - 19	* 55501490	Bracket, PC Board	
2 - 20	* 51683400	PC Board Assy, Rectifier	
2 - 21	* 55501410	Angle, Resistor	
2 - 22	50524480	Resistor, Wire Wound; 700 ohm 40 H	JAPAN
	* 50522380	Resistor, Wire Wound; 1.2k ohm 30 H	All except JAPAN
2 - 23	* 50332900	Angle, Resistor	
2 - 24	50522400	Resistor, Wire Wound; 30 ohm 40 H	
2 - 25	* 55501381	Chassis, Reel Motor	
2 - 26	* 50162960	Cushion, Rubber; B	
2 - 27	* 50162760	Spacer, Rubber Cushion	
2 - 28	* 50161950	Stand-off, Reel Motor	
2 - 29	55300710	Belt, Counter	
2 - 30	* 50332520	Plate, Counter	
2 - 31	50549920	Capacitor, Metalized Mylar 0.1 mfd 400 VAC	
2 - 32	50585150	Counter, Index	
2 - 33	50123984	Fan	
2 - 34	50701341	Motor, Capstan	
2 - 35	50124003	Pulley, Motor (50Hz/60Hz)	JAPAN, GENERAL EXPORT
	50125121	Pulley, Motor (60Hz)	U.S.A., CANADA
2 - 36	* 50237520	Plate, Capstan Motor	
2 - 37	* 50766211	Cushion, Rubber	
2 - 38	* 50332790	Spacer, Rubber Cushion	
2 - 39	* 50123850	Stand-off, Capstan Motor	
2 - 40	* 50491720	PC Board Assy, Freq. Adapt	JAPAN
	* 50491731	PC Board Assy, Freq. Adapt	GENERAL EXPORT
	51340100	Switch, Push	Part of 2-40
2 - 41	50545650	Capacitor, MP; (2 + 0.8) mfd 250V	
2 - 42	51680600	PC Board Assy, Sensing Ampl.	
2 - 43	* 50276910	Bracket, PC Board	
2 - 44	* 50123860	Stand-off, Flywheel	
2 - 45	* 55540580	Plate, Thrust; B	
2 - 46	50277233	Plate, Thrust	
2 - 47	50123802	Flywheel, Capstan	
2 - 48	50123830	Belt, Capstan	
2 - 49	50120440	Capstan Assy	
2 - 50	* 50142190	Plate, Arm Support	
2 - 51	* 55200620	Spring, Pressure; B	
2 - 52	55040161	Arm Assy, Pinch Roller	
2 - 53	50141821	Shaft, Lifter Arm	

(Continued on page 10.)

EXPLODED VIEW-3

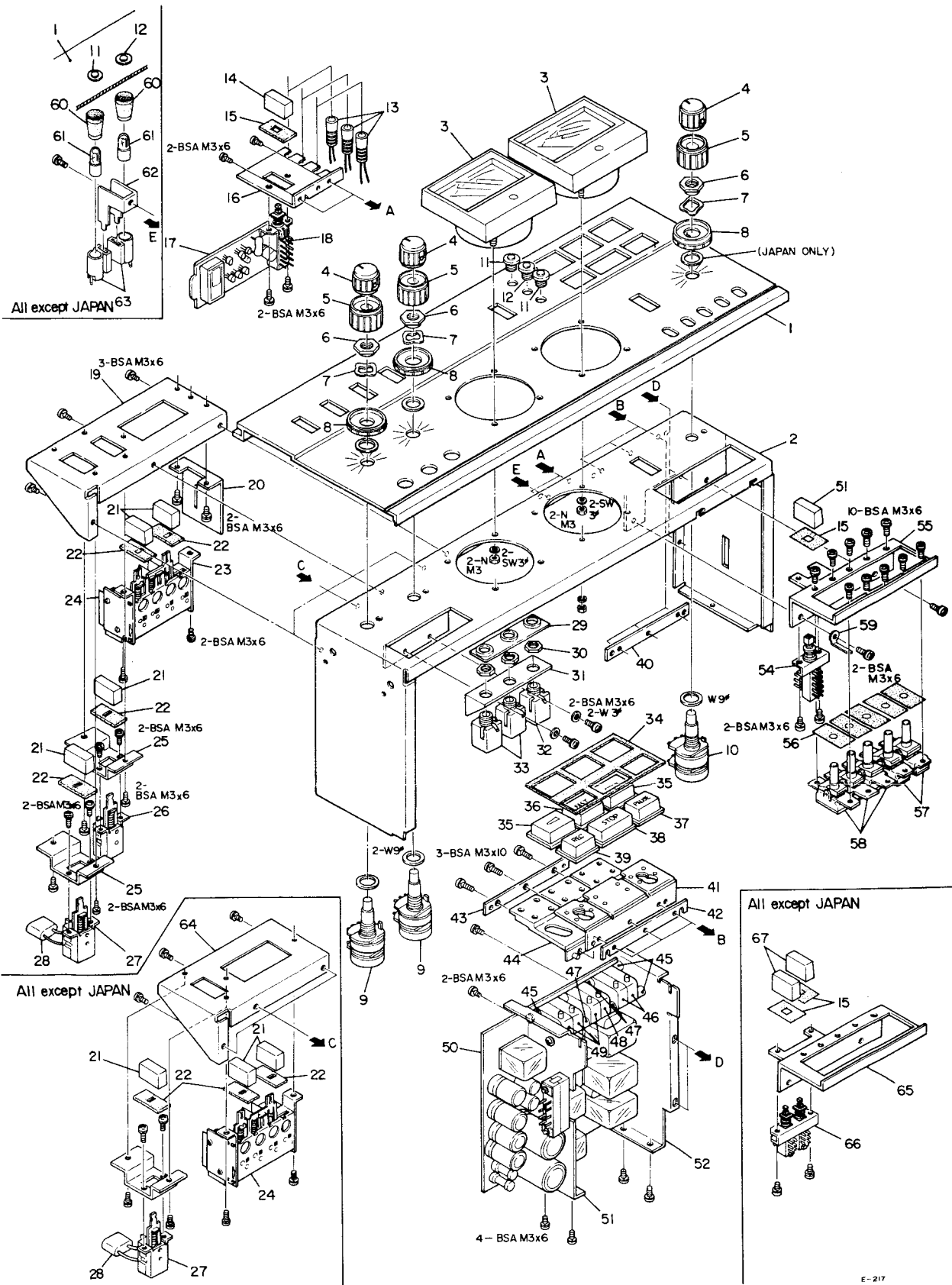

E-217

PARTS LIST-3

REF. NO.	PARTS NO.	DESCRIPTION	REMARKS
3 - 1	55021160	Panel Assy, Ampl.; Trim	JAPAN
	55021170	Panel Assy, Ampl.; Trim	All except JAPAN
3 - 2	* 55501123	Chassis, Ampl.	
3 - 3	50581481	VU Meter	
3 - 4	55440581	Knob, Upper	JAPAN
	55340910	Knob, A	All except JAPAN
3 - 5	55040341	Knob, Lower	JAPAN
	55444270	Knob, B	All except JAPAN
3 - 6	55400821	Lock Nut	JAPAN
3 - 7	55200610	Wave Washer	JAPAN
3 - 8	55300750	Guide, Memory Marker	JAPAN
3 - 9	50537100	Var. Res., 10k ohm A x 2	
3 - 10	50537090	Var. Res., 100k ohm A x 2	
3 - 11	* 55040810	Cover, Lamp (Red)	Part of 3-1
3 - 12	* 55040640	Cover, Lamp (Green)	Part of 3-1
3 - 13	50414650	Lamp, w/Leads	JAPAN
3 - 14	51340180	Button	JAPAN
3 - 15	55501280	Mask, Switch	JAPAN
3 - 16	* 55547340	Bracket, Switch; B	JAPAN
3 - 17	* 51683321	PC Board Assy, Record Muting	JAPAN
3 - 18	* 51340170	Switch, Push	JAPAN
3 - 19	* 55530162	Bracket, Switch	JAPAN
3 - 20	* 55547400	Holder, PC Board	JAPAN
3 - 21	50253530	Button, D	
3 - 22	50253880	Mask, Switch	
3 - 23	50443902	Switch Assy	
3 - 24	* 50332671	Spacer, Insulator Paper	
3 - 25	* 55547330	Bracket, Switch; A	
3 - 26	51340180	Switch, Push	JAPAN
3 - 27	51340090	Switch, Push; Power	
3 - 28	50529050	Spark Killer 0.1 mfd + 120 ohm 400 VAC	JAPAN, GENERAL EXPORT
	50529060	Spark Killer 0.033 mfd + 120 ohm 400 VAC	U.S.A., CANADA
3 - 29	* 55300760	Insulator Mask, Jack	
3 - 30	* 55810420	Nut, MH	
3 - 31	* 55300771	Bracket, Jack Mounting	
3 - 32	50432450	Jack, Phone; 3 Cond.	
3 - 33	50430240	Jack, Phone; Single	
3 - 34	50237300	Rubber Protector, P	
3 - 35	50237201	Button, A	
3 - 36	55300721	Button, FAST	
3 - 37	55300741	Button, PAUSE	
3 - 38	50237221	Button, STOP	
3 - 39	55300731	Button, REC	
3 - 40	* 50237290	Nut Plate, Control	
3 - 41	* 55340430	Hinge, A	
3 - 42	* 50332720	Plate, Hinge Adjusting	
3 - 43	* 50253870	Plate, Retaining	
3 - 44	* 55340440	Hinge, B	
3 - 45	* 55400840	Spacer, A	
3 - 46	50446560	Switch, Micro; VV-15-1A	
3 - 47	* 50237160	Spacer	
3 - 48	50446570	Switch, Micro; VV-15-2A	
3 - 49	50446580	Switch, Micro; VV-15-3A	
3 - 50	* 51683350	PC Board Assy, Control	
3 - 51	* 55501221	Bracket, PC Board Reinforcing; L	
3 - 52	* 55501232	Bracket, PC Board Reinforcing; R	
3 - 53	55300800	Button, OUTPUT	JAPAN
3 - 54	50443960	Switch, Push	
3 - 55	* 55501192	Plate, Lever Switch	JAPAN
3 - 56	55500790	Mask, Lever Switch	
3 - 57	50447210	Switch, Lever; 4PDT	
3 - 58	50447220	Switch, Lever; DPDT	

(Continued on page 10.)

PARTS LIST-4

REF. NO.	PARTS NO.	DESCRIPTION	REMARKS
4 - 1	* 55021090	Panel, Rear Connection	JAPAN
	* 55021140	Panel, Rear Connection	All except JAPAN
4 - 2	* 55501270	Angle, PC Board	
4 - 3	* 50436720	Connector, Plug; 28P	
4 - 4	* 50436730	Connector, Socket; 28P	
4 - 5	* 51683690	PC Board Assy, Timer	JAPAN
4 - 6	* 55540681	Bracket, PC Board; P	JAPAN
4 - 7	50436580	Jack, Pin; 4P	
4 - 8	* 50452060	Terminal Strip, 1L-2P	
4 - 9	* 50233530	Plate, DIN Connector	
4 - 10	50430010	Connector, DIN	
4 - 11	55501151	Adaptor, Fuse Holder	All except GENERAL EXPORT
4 - 12	* 50924500	Holder, Fuse	JAPAN
4 - 13	50411140	Fuse, 2A	JAPAN
	50411140	Fuse, 2A (100V/117V area)	GENERAL EXPORT
	50411010	Fuse, 1A (220V/240V area)	GENERAL EXPORT
	50411440	Fuse, 2A; UL	U.S.A., CANADA
4 - 14	50432700	Socket, 11P	
4 - 15	50433001	Dummy Plug, 11P	
4 - 16	* 50454071	Post, Grounding	
4 - 17	* 51681343	PC Board Assy, Bias Oscillator	
4 - 18	* 55501240	Angle, PC Board	
4 - 19	* 50233760	Plate, PC Board	
4 - 20	* 50491443	PC Board Assy, Record/Meter Ampl.	JAPAN
	* 51683420	PC Board Assy, Record/Meter Ampl.	All except JAPAN
4 - 21	* 50491432	PC Board Assy, Line Out/Phone Ampl.	
4 - 22	* 50491424	PC Board Assy, Playback EQ/MIC Ampl.	
4 - 23	* 55300470	Strain Relief, AC Power Cord	
4 - 24	51280270	Cord, AC Power	JAPAN
	* 50471652	Cord, AC Power	GENERAL EXPORT
	50471661	Cord, AC Power	U.S.A., CANADA
4 - 25	* 50435030	Voltage Selector	GENERAL EXPORT
4 - 26	* 50412280	Holder, Fuse	U.S.A., CANADA

PARTS LIST-2 (Continued from page 5.)

REF. NO.	PARTS NO.	DESCRIPTION	REMARKS
2 - 54	50616691	Solenoid Assy, Pinch Roller	
2 - 55	50529050	Spark Killer, 0.1 mfd + 120 ohm 400 VAC	
2 - 56	50422570	Diode, SIB01-06	
2 - 57	50275690	Cushion, Rubber	
2 - 58	* 50141842	Limit Stop, Pinch Roller	
2 - 59	50220441	Spring, Return	
2 - 60	* 55501320	Plate, Lifter	
2 - 61	55000740	Arm Assy, Lifter; R	
2 - 62	50152501	Shaft, Lifter Arm	
2 - 63	* 50221100	Spring, A	
2 - 64	55000730	Arm Assy, Lifter; L	
2 - 65	* 55340410	Clamp, Wire; A	

PARTS LIST-3 (Continued from page 7.)

REF. NO.	PARTS NO.	DESCRIPTION	REMARKS
3 - 59	* 50939280	Clamp, Wire; B	
3 - 60	* 50419070	Sleeve, Lamp	All except JAPAN
3 - 61	50414580	Lamp, Bayonet Type (8V)	All except JAPAN
3 - 62	* 55501170	Bracket, Lamp Socket Support	All except JAPAN
3 - 63	50415250	Socket, Lamp	All except JAPAN
3 - 64	* 55501181	Bracket, Switch	All except JAPAN
3 - 65	* 55547600	Plate, Lever Switch; A	All except JAPAN
3 - 66	51340200	Switch, Push; 2-Gang	All except JAPAN
3 - 67	55340140	Button	All except JAPAN

INCLUDED ACCESSORIES

REF. NO.	PARTS NO.	DESCRIPTION	REMARKS
	* 51280010	Cords, Input-output Connection, 2 used	
	* RE-702	Empty Reel, 7 inch Small Hub	
	* 57100300	Cleaning Stick (TZ-275)	
	* 50291350	Silicone Cloth	
	* 50291860	Oil and Applicator	
	* 50276971	Rubber Feet (For Horizontal Use)	
	* 50629620	Splicing Tape	
	* 50272880	Sensing Foil	
	* 50411010	Fuse, 1A (220V/240V area)	GENERAL EXPORT
	* 50411140	Fuse, 2A (100V/117V area)	GENERAL EXPORT
	* 50411440	Fuse, 1A-250V UL	U.S.A., CANADA
	* 51014020	A-4300SX Owner's Manual	JAPAN
	* 51014040	A-4300SX Owner's Manual	GENERAL EXPORT
	* 51014030	A-4300SX Owner's Manual	U.S.A., CANADA
	* 51013371	Information Supplement (Open Reel)	U.S.A., CANADA

2. PC BOARD SECTION (Diagram)

1. EQUALIZER, MIC AMPL.

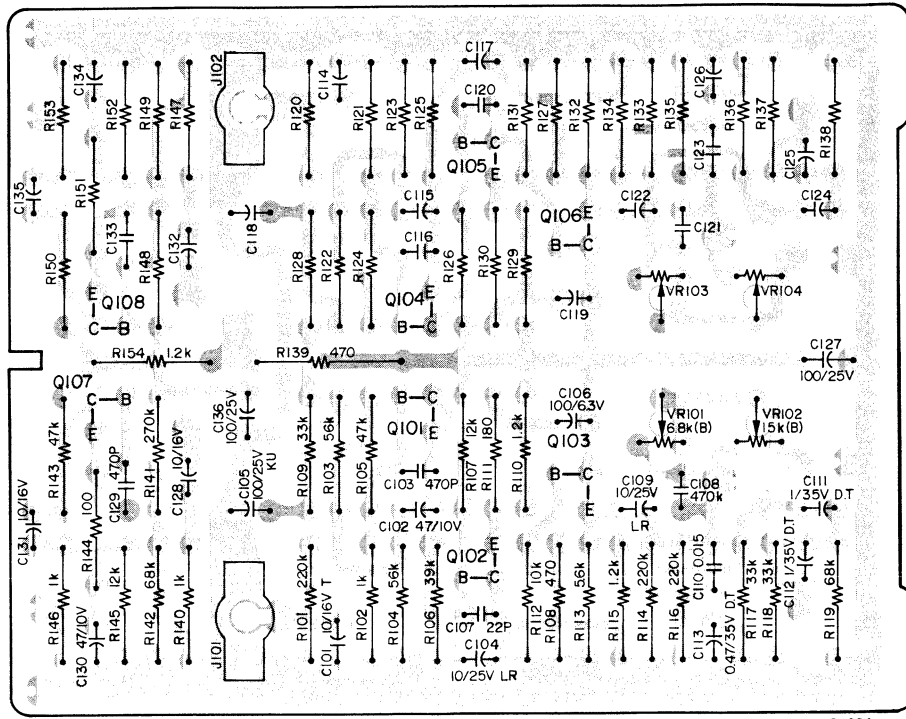

2. LINE, PHONE AMPL.

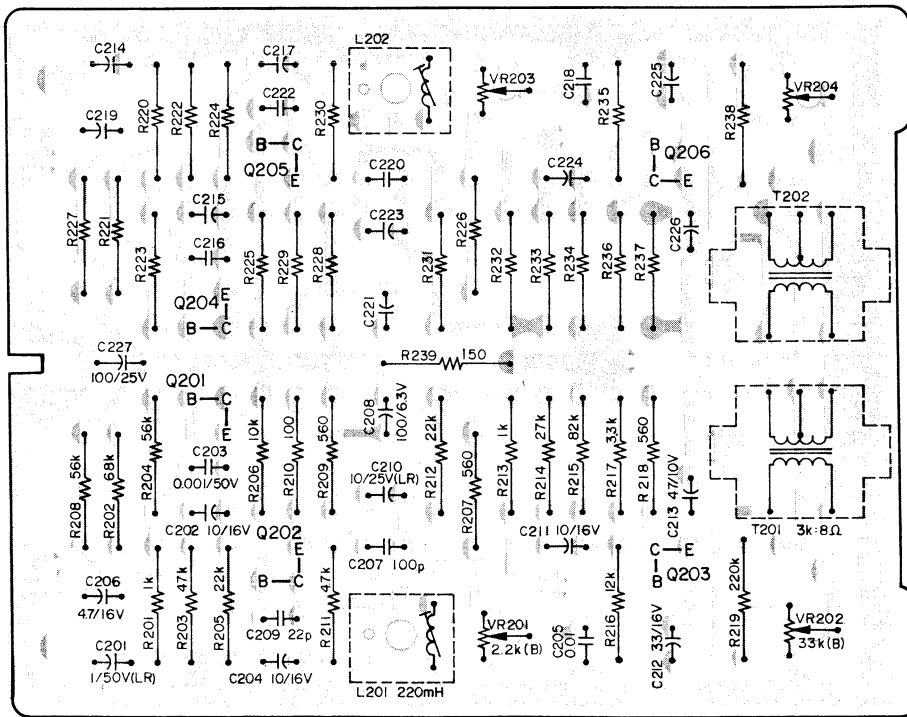

3. RECORD, METER AMPL.

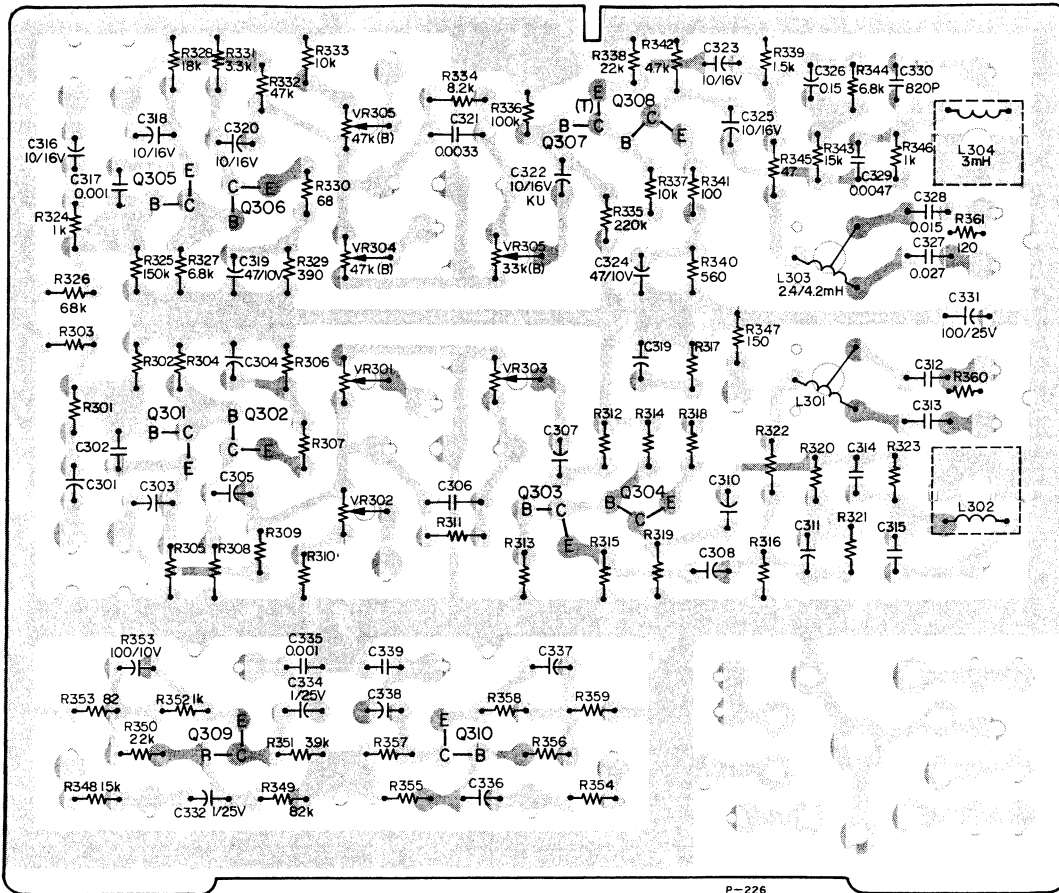

4. BIAS OSC PC BOARD.

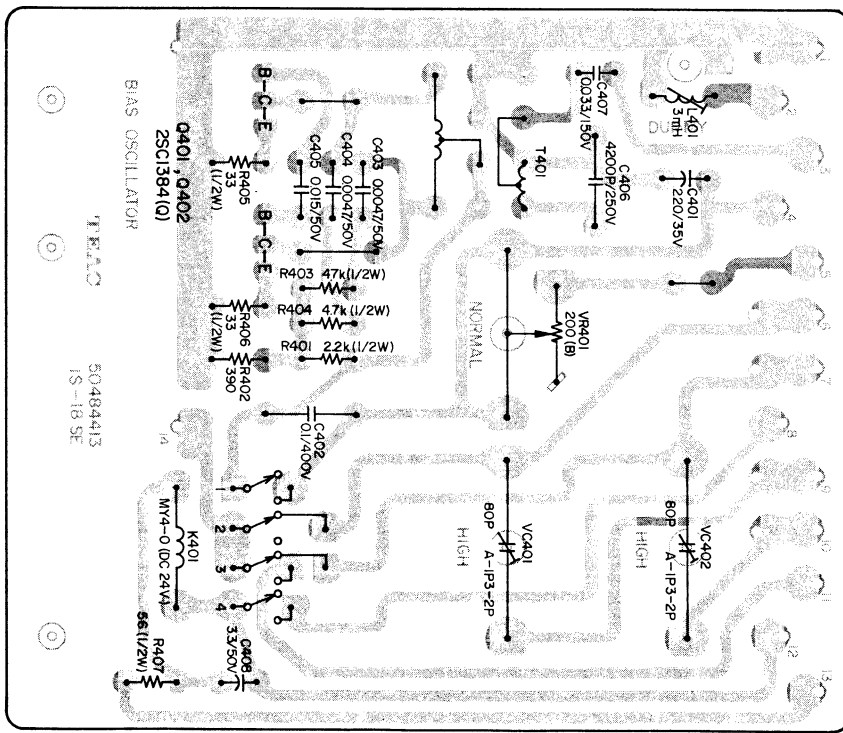

5. CONTROL PC BOARD.

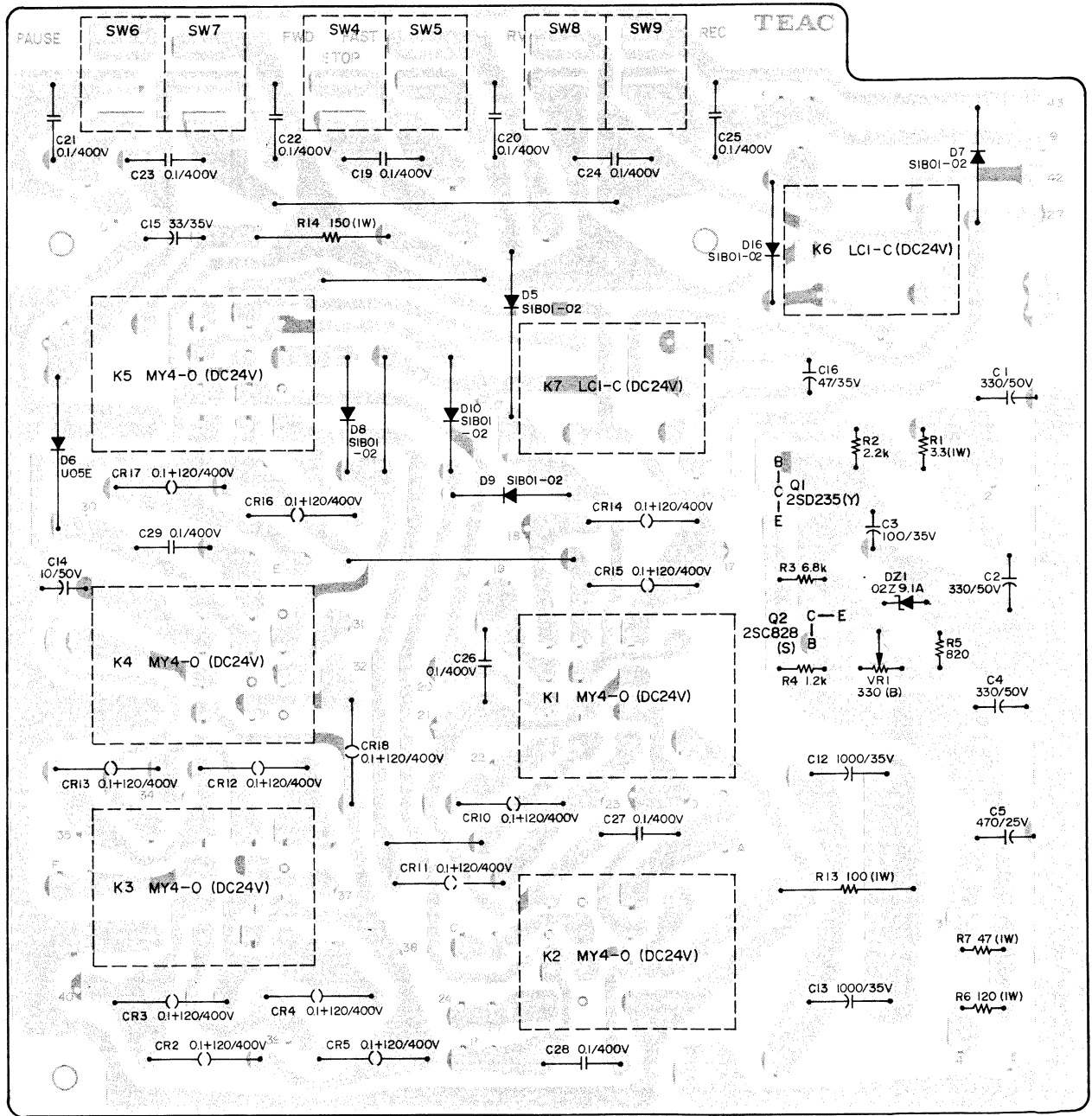

6. RECTIFIER PC BOARD.

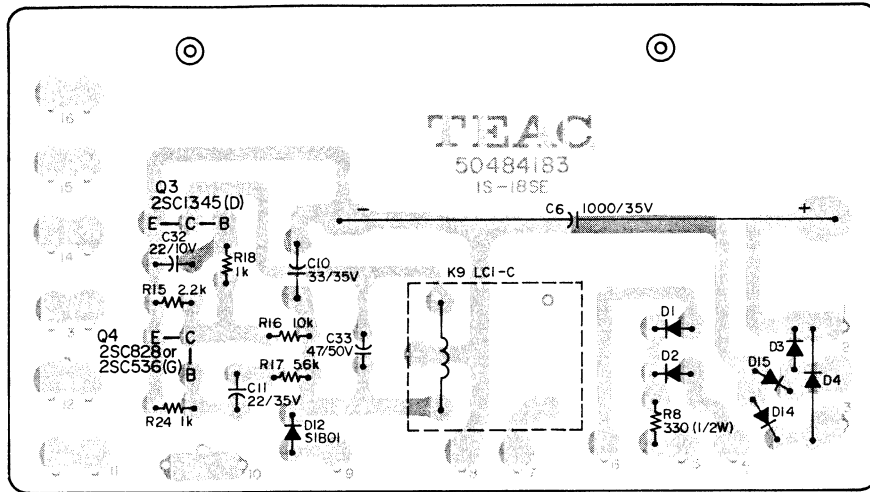

7. REC MUTE PC BOARD (JAPAN)

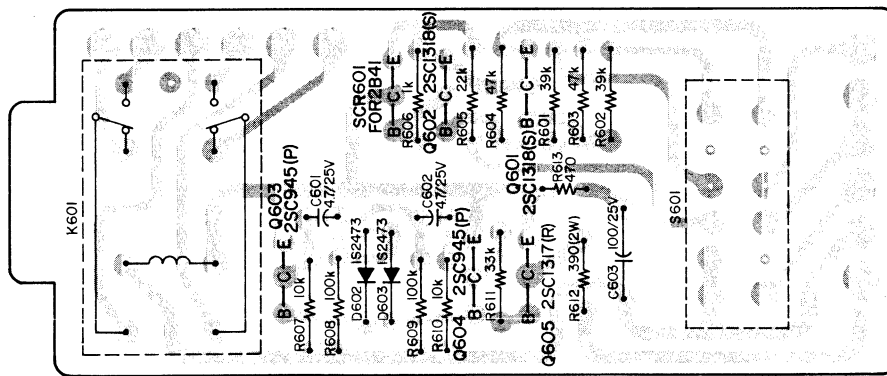

8. TIMER PC BOARD (JAPAN)

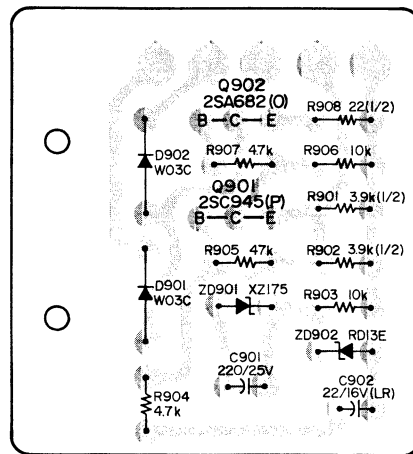

2. PC BOARD SECTION (Parts List)

1. EQUALIZER, MIC AMPL.

REF. NO.	PARTS NO.	DESCRIPTION
	50491424	PC Board Assy
	50484080	PC Board
TRANSISTORS		
Q101/Q104	50424610	2SC1327 (T) or
	50424710	2SC1345 (E), (F)
Q102/Q105	51450380	2SA750 (E) or
	50424870	2SA763 (YL) 5
Q103/Q106	50424860	2SC536 (G) or
	50424600	2SC828 (S)
Q107/Q108	50424610	2SC1327 (T) or
	50424710	2SC1345 (E), (F)

CARBON RESISTORS

All resistors are rated $\pm 5\%$ tolerance and 1/4 watt.

R101/R120	50573380	220k ohm
R102/R121	50572820	1k ohm
R103/R122	50573240	56k ohm
R104/R123	50573240	56k ohm
R105/R124	50573220	47k ohm
R106/R125	50573200	39k ohm
R107/R126	50573080	12k ohm
R108/R127	50572740	470 ohm
R109/R128	50573180	33k ohm
R110/R129	50572840	1.2k ohm
R111/R130	50572640	180 ohm
R112/R131	50573060	10k ohm
R113/R132	50573000	5.6k ohm
R114/R133	50573380	220k ohm
R115/R134	50572840	1.2k ohm
R116/R135	50573380	220k ohm
R117/R136	50518840	33k ohm
R118/R137	50518840	33k ohm
R119/R138	50573260	68k ohm
R139	50572740	470 ohm
R140/R147	50572820	1k ohm
R141/R148	50573400	270k ohm
R142/R149	50573260	68k ohm
R143/R150	50573220	47k ohm
R144/R151	50572580	100 ohm
R145/R152	50573080	12k ohm
R146/R153	50572820	1k ohm
R154	50572840	1.2k ohm

CAPACITORS

C101/C114	51700090	Tant.	10 mfd	16V
C102/C115	50555540	Elec.	47 mfd	10V
C103/C116	50547560	Dip. Mica	470 pfd	50V
C104/C117	51700820	Elec.	10 mfd	25V LR
C105/C118	50549740	Elec.	100 mfd	25V KU
C106/C119	50554230	Elec.	100 mfd	6.3V
C107/C120	50543820	Dip. Mica	22 pfd	50V
C108/C121	50547560	Dip. Mica	470 pfd	50V
C109/C122	51700820	Elec.	10 mfd	25V LR
C110/C123	50548420	Mylar	0.015 mfd	50V
C111/C124	50546701	Dip. Tant.	1 mfd	35V
C112/C125	50546701	Dip. Tant.	1 mfd	35V
C113/C126	50546682	Dip. Tant.	0.47 mfd	35V
C127	50554170	Elec.	100 mfd	25V

REF. NO.	PARTS NO.	DESCRIPTION
C128/C132	50554050	Elec. 10 mfd 16V
C129/C133	50547560	Dip. Mica 470 pfd 50V
C130/C134	50555540	Elec. 47 mfd 10V
C131/C135	50554050	Elec. 10 mfd 16V
C136	50554170	Elec. 100 mfd 25V

VARIABLE RESISTORS

VR101/VR103	50533580	Semi-fixed, 6.8k ohm - B
VR102/VR104	50533540	Semi-fixed, 15k ohm - B

MISCELLANEOUS

J101/J102	50435000	Jack, Pin
-----------	----------	-----------

2. LINE, PHONE AMPL.

REF. NO.	PARTS NO.	DESCRIPTION
	50491432	PC Board Assy
	50484090	PC Board
TRANSISTORS		
Q201/Q204	50424940	2SC900 (E) or
	50423770	2SC644 (T)
Q202/Q205	50450380	2SA750 (E) or
	50424870	2SA763 (YL)
Q203/Q206	50424860	2SC536 (G) or
	50424600	2SC828 (S)
CARBON RESISTORS		
All resistors are rated $\pm 5\%$ tolerance and 1/4 watt.		
R201/R220	50572820	1k ohm
R202/R221	50573260	68k ohm
R203/R222	50573220	47k ohm
R204/R223	50573240	56k ohm
R205/R224	50573140	22k ohm
R206/R225	50573060	10k ohm
R207/R226	50572760	560 ohm
R208/R227	50573240	56k ohm
R209/R228	50572760	560 ohm
R210/R229	50572580	100 ohm
R211/R230	50572980	4.7k ohm
R212/R231	50573140	22k ohm
R213/R232	50572820	1k ohm
R214/R233	50573160	27k ohm
R215/R234	50573280	82k ohm
R216/R235	50573080	12k ohm
R217/R236	50572940	3.3k ohm
R218/R237	50572760	560 ohm
R219/R238	50573380	220k ohm
R239	50572620	150 ohm

REF. NO.	PARTS NO.	DESCRIPTION
CAPACITORS		
C201/C214	51700860	Elec. 1 mfd 50V LR
C202/C215	50546561	Dip. Tant. 10 mfd 16V
C203/C216	50548320	Mylar 0.001 mfd 50V
C204/C217	50554050	Elec. 10 mfd 16V
C205/C218	50548020	Mylar 0.01 mfd 50V
C206/C219	50554430	Elec. 4.7 mfd 16V
C207/C220	50547440	Dip. Mica 100 pfd 50V
C208/C221	50554230	Elec. 100 mfd 6.3V
C209/C222	50543820	Dip. Mica 22 pfd 50V
C210/C223	51700820	Elec. 10 mfd 25V LR
C211/C224	50554050	Elec. 10 mfd 16V
C212/C225	50554260	Elec. 33 mfd 16V
C213/C226	50555540	Elec. 47 mfd 10V
C227	50554170	Elec. 100 mfd 25V

VARIABLE RESISTORS

VR201/VR203	50533640	Semi-fixed, 2.2k ohm - B
VR202/VR204	50533960	Semi-fixed, 33k ohm - B

COILS/TRANSFORMER

L201/L202	50566640	Coil, Choke 220 μ H
T201/T202	50563410	Transformer, Output 3k ohm:8 ohm or
	50562141	Transformer, Output 3k ohm:8 ohm

3. RECORD, METER AMPL.

REF. NO.	PARTS NO.	DESCRIPTION
	50491443	PC Board Assy (JAPAN)
	51683420	PC Board Assy (All except JAPAN)
	51671092	PC Board
TRANSISTORS		
Q301/Q305	50424940	2SC900 (E) or
	50423770	2SC644 (T)
Q302/Q306	51450380	2SA750 (E) or
	50424870	2SA763 (YL)
Q303/Q307	50424940	2SC900 (E)
	50423770	2SC644 (T)
Q304/Q308	51450380	2SA750 (E)
	50424870	2SA763 (YL)
Q309/Q310	50424860	2SC536 (G)
	50424600	2SC828 (S)

CARBON RESISTORS

All resistors are rated $\pm 5\%$ tolerance and 1/4 watt.

R301/R324	50570820	1k ohm
R302/R325	50571340	150k ohm
R303/R326	50571260	68k ohm
R304/R327	50571020	6.8k ohm
R305/R328	50571120	18k ohm
R306/R329	50570720	390 ohm

REF. NO.	PARTS NO.	DESCRIPTION
R307/R330	50570540	68 ohm
R308/R331	50570940	3.3k ohm
R309/R332	50571220	47k ohm
R310/R333	50571060	10k ohm
R311/R334	50515480	8.2k ohm
R312/R335	50571380	220k ohm
R313/R336	50571300	100k ohm
R314/R337	50571060	10k ohm
R315/R338	50571140	22k ohm
R316/R339	50570860	1.5k ohm
R317/R340	50570760	560 ohm
R318/R341	50570580	100 ohm
R319/R342	50570980	4.7k ohm
R320/R343	50571100	15k ohm
R321/R344	50571260	68k ohm
R322/R345	50570580	100 ohm
R323/R346	50570820	1k ohm
R347	50570620	150 ohm
R348/R354	50571100	15k ohm
R349/R355	50571280	82k ohm
R350/R356	50571140	22k ohm
R351/R357	50570960	3.9k ohm
R352/R358	50570820	1k ohm
R353/R359	50570560	82 ohm
R360/R361	50570600	120 ohm

CAPACITORS

C301/C316	50554050	Elec. 10 mfd 16V
C302/C317	50548320	Mylar 0.001 mfd 50V
C303/C318	50554050	Elec. 10 mfd 16V
C304/C319	50555540	Elec. 47 mfd 10V
C305/C320	50549770	Elec. 10 mfd 16V KU
C306/C321	50548300	Mylar 0.0033 mfd 50V
C307/C322	50554050	Elec. 10 mfd 16V
C308/C323	50554050	Elec. 10 mfd 16V
C309/C324	50555540	Elec. 47 mfd 10V
C310/C325	50554050	Elec. 10 mfd 16V
C311/C326	50548310	Mylar 0.15 mfd 50V
C312/C327	50548420	Mylar 0.015 mfd 50V
C313/C328	50548290	Mylar 0.022 mfd 50V
		(JAPAN)
	50548330	Mylar 0.027 mfd 50V
		(All except JAPAN)
C314/C329	50548130	Mylar 0.0047 mfd 50V
C315/C330	50543440	Polyst. 820 pfd 50V
C331	50554170	Elec. 100 mfd 25V
C332/C336	50554670	Elec. 1 mfd 25V
C333/C337	50554570	Elec. 100 mfd 10V
C334/C338	50554670	Elec. 1 mfd 25V
C335/C339	50548320	Mylar 0.001 mfd 50V

VARIABLE RESISTORS

VR301/VR304	50533520	Semi-fixed, 47k ohm - B
VR302/VR305	50533520	Semi-fixed, 47k ohm - B
VR303/VR306	50533960	Semi-fixed, 33k ohm - B

COILS

L301/L303	50566370	Record EQ 2.4mH - 4.2mH
L302/L304	50566590	Trap 3mH or
	50566300	Trap 3mH

REF.NO.	PARTS NO.	DESCRIPTION
---------	-----------	-------------

MISCELLANEOUS

50432730	Socket, 9P
50429060	Spring, Clamp

4. BIAS OSC PC BOARD.

REF.NO.	PARTS NO.	DESCRIPTION
---------	-----------	-------------

51681343	PC Board Assy
----------	---------------

50484413	PC Board
----------	----------

TRANSISTORS

Q401/Q402	50424750	2SC1384 (Q)
	50333040	Heat Sink

RELAY

K401	50610690	4PDT DC24V
------	----------	------------

CARBON RESISTORS

R401	50574900	2.2k ohm 1/2W or
	50517860	2.2k ohm 1/2W
R402	50570720	390 ohm 1/4W
R403, R404	50574980	4.7k ohm 1/2W
R405, R406	50574460	33 ohm 1/2W
R407	50570520	56 ohm 1/4W

CAPACITORS

C401	50554380	Elec.	220 mfd	35V
C402	50549920	Metalized Mylar	0.1 mfd	400V
C403, C404	50548910	Mylar	0.0047 mfd	50V 5%
C405	50548870	Mylar	0.015 mfd	50V 5%
C406	50544040	Mica	4200 pfd	250V 5%
C407	51700160	Mylar	0.033 mfd	150V
C408	50555730	Elec.	3.3 mfd	50V

VARIABLE RESISTOR

VR401	50539020	Semi-fixed, 200 ohm - B
-------	----------	-------------------------

TRIMMER CAPACITORS

VC401, VC402	50547070	Max. 80 pfd
--------------	----------	-------------

COIL/TRANSFORMER

L401	50566581	Dummy Load, 3mH
T401	50563550	Oscillator

5. CONTROL PC BOARD.

REF.NO.	PARTS NO.	DESCRIPTION
---------	-----------	-------------

51683350	PC Board Assy
----------	---------------

51673350	PC Board
----------	----------

TRANSISTORS

Q1	50424620	2SD235 (Y)
Q2	50424860	2SC536 (G) or
	50424600	2SC828 (S)

DIODES

DZ1	50425150	Zener, WZ091 or
	50422900	Zener, 02Z-9.1A
D5	50422560	SIB01-02
D6	51430180	U05E
D7~D10	50422560	SIB01-02
D16	50422560	SIB01-02

RELAYS

K1~K5	50610690	4PDT DC24V
K6, K7	50611150	SPDT DC24V

RESISTORS

All resistors are rated $\pm 5\%$ tolerance, 1/4 watt and of carbon type unless otherwise noted.

R1	50525440	3.3 ohm	1R Wire Wound
R2	50570900	2.2k ohm	
R3	50571020	6.8k ohm	
R4	50570840	1.2k ohm	
R5	50570800	820 ohm	
R6	50526410	120 ohm	1R Wire Wound
R7	50526270	47 ohm	1R Wire Wound
R13	50526290	100 ohm	1L Wire Wound
R14	50526280	150 ohm	1L Wire Wound

CAPACITORS

C1, C2	50554990	Elec.	330 mfd	50V
C3	50554630	Elec.	100 mfd	35V
C4	50554990	Elec.	330 mfd	50V
C5	50554420	Elec.	470 mfd	25V
C12, C13	50551380	Elec.	1000 mfd	35V
C14	50555690	Elec.	10 mfd	50V KU
C15	50554750	Elec.	33 mfd	35V
C16	50554520	Elec.	47 mfd	35V
C19~C29	50549920	Metalized Mylar	0.1 mfd	400VAC
CR2~CR5	50529050	Spark Killer	0.1 mfd + 120 ohm	400VAC
CR10~CR18	50529050	Spark Killer	0.1 mfd + 120 ohm	400VAC

MISCELLANEOUS

50332910	Sheet, Insul.
----------	---------------

6. RECTIFIER PC BOARD.

REF. NO.	PARTS NO.	DESCRIPTION
	51683400	PC Board Assy
	50484183	PC Board
TRANSISTORS		
Q3	50424830	2SC1345 (D)
Q4	50424860	2SC536 (G) or
	50424600	2SC828 (S)
DIODES		
D1~D4	50422560	SIB01-02
D12	50422560	SIB01-02
D14, D15	50422560	SIB01-02
RELAY		
K9	50611150	SPDT DC24V
CARBON RESISTORS		
All resistors are rated $\pm 5\%$ tolerance and 1/4 watt unless otherwise noted.		
R8	50574700	330 ohm 1/2W
R15	50570900	2.2k ohm
R16	50571060	10k ohm
R17	50571000	5.6k ohm
R18, R24	50570820	1k ohm
CAPACITORS		
C6	50555110	Elec. 1000 mfd 35V
C10	50554750	Elec. 33 mfd 35V
C11	50554900	Elec. 22 mfd 35V
C32	50554720	Elec. 22 mfd 10V
C33	50554580	Elec. 47 mfd 50V

7. REC MUTE PC BOARD (JAPAN)

REF. NO.	PARTS NO.	DESCRIPTION
	51683320	PC Board Assy
	51673320	PC Board
TRANSISTORS		
Q601, Q602	50426250	2SC1318 (S) or (R)
Q603, Q604	50425210	2SC945 (P) or (K)
	50423830	2SC536 (F) or (G)
Q635	50424670	2SC1317 (R) or (S)
THYRISTOR		
SCR601	50428040	FOR2B41

REF. NO.	PARTS NO.	DESCRIPTION
DIODES		
D602, D603	50425500	1S2473
RELAY		
K601	50611280	Sub-miniature
RESISTORS		
All resistors are rated $\pm 5\%$ tolerance, 1/4 watt and of carbon type unless otherwise noted.		
R601, R602	51813200	39k ohm
R603, R604	51813220	47k ohm
R605	51813140	22k ohm
R606	51812820	1k ohm
R607, R610	51813060	10k ohm
R608, R609	51813180	33k ohm
R611	51813180	33k ohm
R612	51806720	390 ohm 2W Wire Wound
R613	51812740	470 ohm
CAPACITORS		
C601, C602	50554530	Elec. 4.7 mfd 25V
C603	50554170	Elec. 100 mfd 25V
MISCELLANEOUS		
S601	51340170	Switch, Push; 4PDT

8. TIMER PC BOARD (JAPAN)

REF. NO.	PARTS NO.	DESCRIPTION
	51683690	PC Board Assy
	51673690	PC Board
Q901	50425210	Transistor, 2SC945 (P)
Q902	50424990	Transistor, 2SA682 (O)
ZD901	51430550	Zener Diode, RD16EB or
	50425260	Zener Diode, XZ175
ZD902	51430860	Zener Diode, RD13E
D901, D902	51430890	Diode, W03C
R901, R902	50574960	Resistor, Carbon; 3.9k ohm 1/2W
R903, R906	50571060	Resistor, Carbon; 10k ohm 1/4W
R904, R907	50570980	Resistor, Carbon; 4.7k ohm 1/4W
R905	50571220	Resistor, Carbon; 47k ohm 1/4W
R908	50574420	Resistor, Carbon; 22 ohm 1/2W
C901	50554180	Capacitor, Elec.; 220 mfd 25V
C902	51700780	Capacitor, Elec.; 22 mfd 16V LR

ASSEMBLING HARDWARE CODING LIST

All screws conform to ISO standards, and have crossrecessed heads, unless otherwise noted. ISO screws have the head inscribed with a point as in the figure to the right.



FOR EXAMPLE:

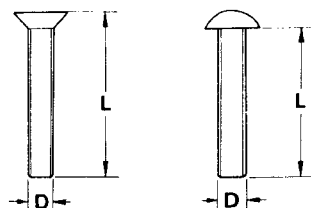
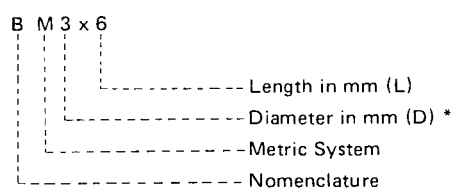

* Inner dia. for washers and nuts

	Code	Name	Type		Code	Name	Type
MACHINE SCREW	R	Round Head Screw		TAPPING SCREW	BTA	Binding Head Tapping Screw(A Type)	
	P	Pan Head Screw			BTB	Binding Head Tapping Screw(B Type)	
	T	Stove Head Screw (Truss)			RTA	Round Head Tapping Screw(A Type)	
	B	Binding Head Screw			RTB	Round Head Tapping Screw(B Type)	
WOOD SCREW	F	Flat Countersunk Head Screw		SETSCREW	SF	Hex Socket Setscrew(Flat Point)	
	O	Oval Countersunk Head Screw			SC	Hex Socket Setscrew(Cup Point)	
	RW	Round Head Wood Screw			SS	Slotted Socket Setscrew(Flat Point)	
SEMS SCREW	FW	Flat Countersunk Wood Screw		WASHER	E	E-Ring (Retaining Washer)	
	OW	Oval Countersunk Wood Screw			W	Flat Washer (Plain)	
SEMS SCREW	BSA	Binding Head SEMS Screw(A Type)		SW	Lock Washer (Spring)		
	BSB	Binding Head SEMS Screw(B Type)		LWI	Lock Washer (Internal Teeth)		
	BSF	Binding Head SEMS Screw(F Type)		LWE	Lock Washer (External Teeth)		
	PSA	Pan Head SEMS Screw(A Type)		TW	Trim Washer (Countersunk)		
	PSB	Pan Head SEMS Screw(B Type)		NUT	N	Hex Nut	

A-4300SX

Stereo Tape Deck

TEAC®

TEAC CORPORATION

3-7-3, NAKA-CHO, MUSASHINO, TOKYO PHONE: (0422) 53-1111

TEAC CORPORATION OF AMERICA

7733 TELEGRAPH ROAD, MONTEBELLO, CALIFORNIA 90640 PHONE: (213) 726-0303

TEAC HONGKONG LIMITED

FLAT 78, PORTLAND HOUSE, 7TH FLOOR, BLOCK C, No. 41-D, MA TAU WEI ROAD,
KOWLOON, HONGKONG PHONE: 3-659071-4
