



Suburban RV COOKING APPLIANCES

SERVICE & TRAINING MANUAL



DROP-IN COOKTOPS



17" RANGES • 22" RANGES • SLIDE-IN COOKTOPS

TABLE OF CONTENTS

	PAGE
Introduction.....	3
Model Variations, Descriptions and Serial Number Location.....	4
Range and Cooktop Model Numbers	5
Slide-In Cooktop Model Numbers.....	6
Drop-In Cooktop Model Numbers.....	7
INSTALLATION INSTRUCTIONS	
Slide-In Cooktops and Ranges	8
Drop-In Cooktops.....	9
Cooking Appliance Terminology	10
Manifold Identification Information.....	11
Burner Identification Information.....	12
TROUBLE SHOOTING GUIDE	
Ranges	13
Slide-In and Drop-In Cooktops	14
Operating Instructions	15
Range Door Removal Instructions.....	15
Warranty Information	16

COOKING APPLIANCE INTRODUCTION

This Service and Training Manual provided by the Suburban Products Factory Service Department is intended to be used by qualified service technicians only as a valuable tool in terms of product identification, troubleshooting and diagnosis of service issues, and as an outline of information concerning proper procedures for filing warranty service claims.

Included in this manual are product and component identification descriptions, sequence of operation information, maintenance and service recommendations, and warranty processing procedures. In addition to the information available in this manual, other resources for servicing Suburban RV appliances include our website - **www.AIRXCEL.com**, our Factory Service Department Hotline at **423-775-2131 EXT 7102**, and our Customer Service Department at **423-775-2131 EXT 7101**.

Having an understanding of the appliance sequence of operation and a thorough comprehension of how the individual components function is of the utmost importance to ensure proper troubleshooting and diagnosis. Another point of emphasis is the adherence to proper installation which includes variables such as gas pressure, along with constant measurable factors such as the compliance to the physical installation tolerances and clearances. This manual is designed to assist service technicians in making the correct diagnosis efficiently.

Proper maintenance and service of an appliance is of the utmost importance. Failure to keep the appliance clean and well maintained is a significant contributing factor in component breakdown and premature failure of the appliance.

MODEL VARIATIONS

1. These units are certified by Underwriters Laboratories (UL) for the U.S.A. and Canada.
2. To determine your exact model, use the chart shown below:

SUBURBAN RV RANGE/COOKTOP MODEL NUMBER POSITIONS									
1	2	3	4	5	6	7	8	9	10
BRAND	TYPE	BURNER TYPE	THERMOSTAT	BURNERS	OVEN MODELS	TOP COLOR (PORCELAIN)	DOOR COLOR (PAINTED)	IGNITION	OPTIONS
S=Suburban	R=Range D=Drop-In C=Cooktop (Slide-In)	N=Conventional S=Sealed	A=Mercury Free	2=2-Burner 3=3-Burner	S=17" Oven L=22" Oven	B=Black W=White S=Stainless G=Glass P=Porcelain Stainless	B=Black W=White S=Stainless G=Black Glass	M=Match E=Piezo S=Spark	V=120V Element Z=Deluxe Cooking Grate X=Extension

3. The complete model, serial number and stock number are located on the UL label located under the top, as shown in Figure 3. This information will be needed when servicing the appliance or ordering parts. Record the information and retain for future reference. Replacement parts can be ordered through your local dealer or Suburban Service Center. To obtain information on locating a local service agency, call AIRXCEL, INC. - Suburban Division Customer Service Department, 423-775-2131, EXT 7101 or Fax: 423-775-7015.

4. These units are designed certified for use with LP/Propane gas only. Do not attempt to convert to natural gas.
5. Gas supply pressure for checking of the regulator setting shall be at least 1" W.C. above the suggested manifold pressure.

Minimum Gas Supply Pressure - 11" W.C.
Maximum Gas Supply Pressure - 14" W.C.

NOTE: Our service technicians are available to assist you in making repairs or parts replacements from 8:00 am to 5:00 pm, Monday through Friday (except holidays), by calling 423-775-2131, Extension 7102. Our e-mail address is SMCSales@suburbanmfg.com or log onto our website at www.AIRXCEL.com.

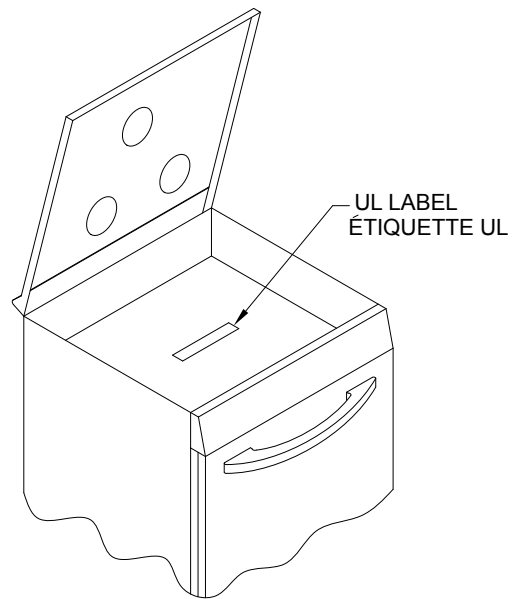

SUBURBAN SERIAL NUMBER INFORMATION

All Suburban Serial Numbers manufactured after January 1990, will be nine digits. The first two (2) digits signify the year of manufacture. The next set of digits, indicate the week of the year and the remaining digits are serial numbers.

EXAMPLE SERIAL NUMBER DESCRIPTION

Sample Serial Number:

07 25 03340

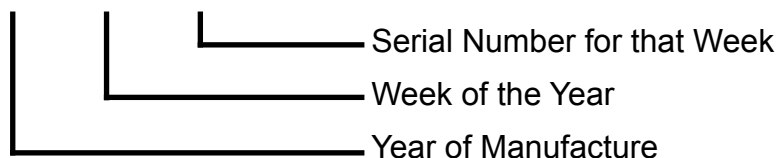

RANGE AND COOKTOP MODEL NUMBERS

17" AND 22" CONVENTIONAL BURNER MERCURY FREE CONTROL RANGES

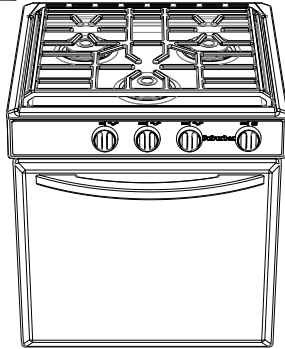
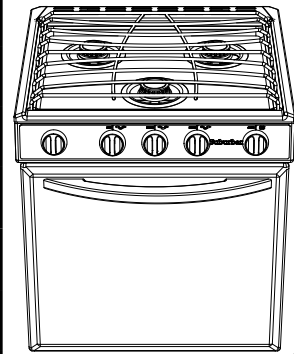

Model Number	Burners	Oven Height	Top Porcelain	Door	Top Ignition
SRNA3SBBE	3	17"	Black	Black	Piezo
SRNA3SBBM	3	17"	Black	Black	Match
SRNA3SBGE	3	17"	Black	Black w/ Glass	Piezo
SRNA3SBGM	3	17"	Black	Black w/ Glass	Match
SRNA3SPSS	3	17"	Stainless ¹	Stainless	Spark ²
SRNA3LBBE	3	22"	Black	Black	Piezo
SRNA3LBBM	3	22"	Black	Black	Match
SRNA3LBGE	3	22"	Black	Black w/ Glass	Piezo
SRNA3LBGM	3	22"	Black	Black w/ Glass	Match
SRNA3LPSS	3	22"	Stainless ¹	Stainless	Spark ²

17" AND 22" SEALED BURNER MERCURY FREE CONTROL RANGES

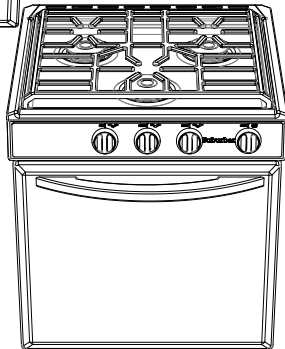
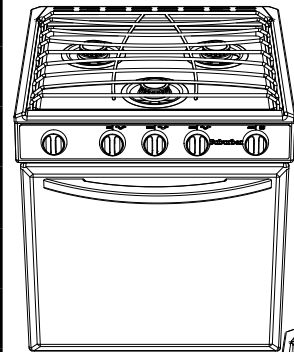

Model Number	Burners	Oven Height	Top Porcelain	Door	Top Ignition
SRSA3SBBE	3	17"	Black	Black	Piezo
SRSA3SBBM	3	17"	Black	Black	Match
SRSA3SBGE	3	17"	Black	Black w/ Glass	Piezo
SRSA3SBSE	3	17"	Black	Stainless	Piezo
SRSA3SPSS	3	17"	Stainless ¹	Stainless	Spark ²
SRSA3LBBE	3	22"	Black	Black	Piezo
SRSA3LBBM	3	22"	Black	Black	Match
SRSA3LBGE	3	22"	Black	Black w/ Glass	Piezo
SRSA3LBSE	3	22"	Black	Stainless	Piezo
SRSA3LPSS	3	22"	Stainless ¹	Stainless	Spark ²

¹ Porcelain with appearance of stainless steel

² Spark igniter requires 1 AAA battery (included)

RANGE AND COOKTOP MODEL NUMBERS

SLIDE-IN COOKTOPS - CONVENTIONAL BURNERS

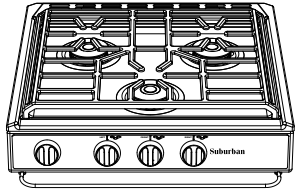
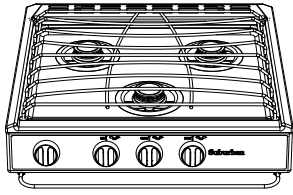

Model Number	Burners	DESCRIPTION	Ignition
SCN3BM	3	Slide-in, Black	Match
SCN3BE	3	Slide-in, Black	Piezo
SCNA3PS	3	Slide-in, Stainless ¹	Spark ²

SLIDE-IN COOKTOPS - SEALED BURNERS

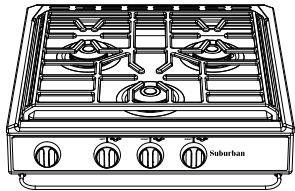
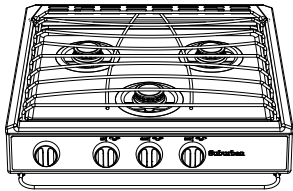

Model Number	Burners	DESCRIPTION	Ignition
SCS3BM	3	Slide-in, Black	Match
SCS3BE	3	Slide-in, Black	Piezo
SCSA3PS	3	Slide-in, Stainless ¹	Spark ²

SLIDE-IN AND RANGE BI-FOLD COVERS

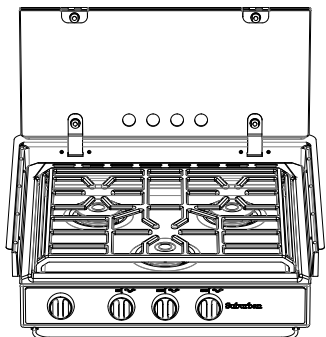
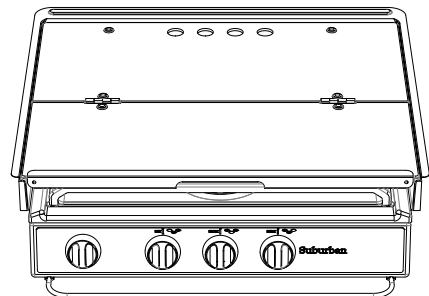

Part Number	DESCRIPTION
2814A	Bi-Fold Cover, Black (NOT SHOWN)
2815A	Bi-Fold Cover, White (NOT SHOWN)
2985A	FLUSH MOUNT GLASS COVER

FLUSH MOUNT GLASS COVER

¹ Porcelain with appearance of stainless steel
² Spark igniter requires 1 AAA battery (included)

RANGE AND COOKTOP MODEL NUMBERS

DROP-IN COOKTOPS

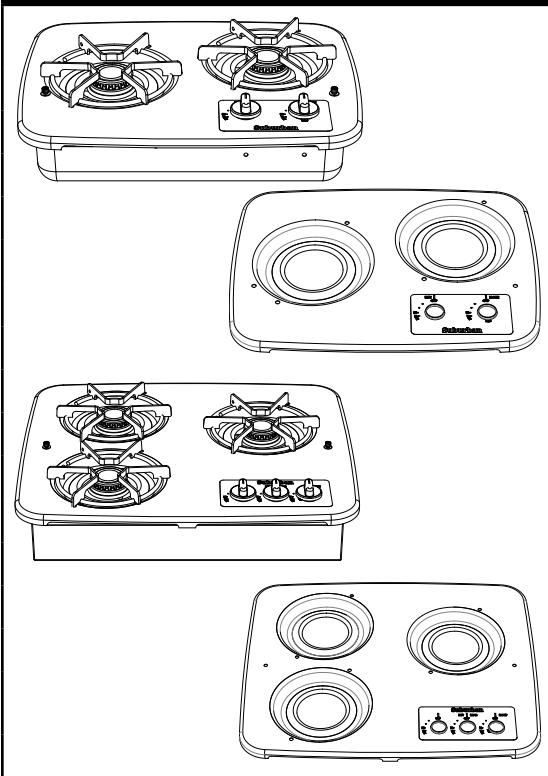
	Model Number	Burners	DESCRIPTION
	SDN2	2	RV Drop-In Cook Top (Burner Box Only)
SDN2SS	2	RV Drop-In Cook Top with Stainless Top	
SDN2BK	2	RV Drop-In Cook Top with Black Top	
SDN2WH	2	RV Drop-In Cook Top with White Top	
SDN2-SS	2	SDN2 Stainless Steel (Top Only)	
SDN2-BK	2	SDN2 Black (Top Only)	
SDN2-WH	2	SDN2 White (Top Only)	
SDN3	3	RV Drop-In Cook Top (Burner Box Only)	
SDN3SS	3	RV Drop-In Cook Top with Stainless Top	
SND3BK	3	RV Drop-In Cook Top with Black Top	
SDN3WH	3	RV Drop-In Cook Top with White Top	
SDN3-SS	3	SDN2 Stainless Steel (Top Only)	
SDN3-BK	3	SDN2 Black (Top Only)	
SDN3-WH	3	SDN2 White (Top Only)	
SDN2H	2	Hi Pressure RV Drop-In Cook Top (Burner Box Only)	
SDN2H	2	SDN2H Black (Top Only)	

DROP-IN COVERS

<p style="text-align: center;">PICTURE NOT AVAILABLE</p>	DESCRIPTION	
	2968AST	SDN2 Cover, Stainless Steel
	2968ABK	SND2 Cover, Black
	2968AWH	SDN2 Cover, White
	2697AST	SDN2 Cover, Stainless Steel (With Side Shields)
	2967ABK	SND2 Cover, Black (With Side Shields)
	2967AWH	SDN2 Cover, White (With Side Shields)
	2948AST	SDN3 Cover, Stainless Steel
	2948ABK	SND3 Cover, Black
	2948AWH	SDN3 Cover, White
	2947AST	SDN3 Cover, Stainless Steel (With Side Shields)
	2947ABK	SND3 Cover, Black (With Side Shields)
	2947AWH	SDN3 Cover, White (With Side Shields)
		SDN2H Cover, Black (With Side Shields)

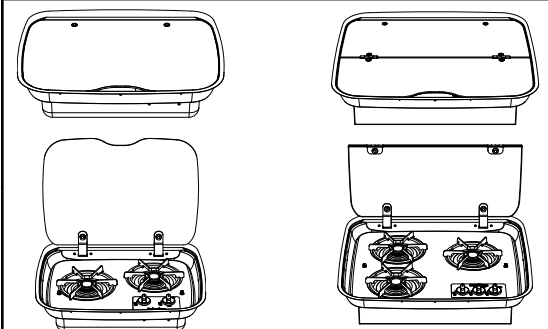
	2983A	Flush Mount Glass Cover, 2 Burner
	2990A	Flush Mount Glass Cover, 3 Burner

FLUSH MOUNT GLASS COVER

INSTALLATION INSTRUCTIONS SCN(S) and SRN(S)A

WARNING! Installation of this appliance must be made in accordance with the written instructions provided in this manual. No agent, representative or employee of Suburban or other person has the authority to change, modify or waive any provision of the instructions contained in this manual.

- In the U.S.A., the installation must conform with state or other codes or in the absence of such codes, refer to the latest edition of:
 - Standard for Recreational Vehicles NFPA 1192
 - National Fuel Gas Code ANSI Z223.1/NFPA 54
- In Canada, the installation must be in accordance with:
 - Standard CAN/CSA Z-240.4.2-08, Installation Requirements for Propane Appliances and Equipment in Recreational Vehicles.
 - Any applicable local codes and regulations
- Minimum clearances from combustible walls above and below counter: (See Figure 1A)

MODELS	Center of Burner Head(s) to adjacent vertical combustible material above the cooking surface burners.			
	Below Counter Sides, Rear and Bottom	Right Sidewall	Left Sidewall	Backwall
SCN3/SCNA3 SCS3/SCSA3	0"	6"	6"	9"
SRNA3 SRSA3	0"	6"	6"	9"

- Cut-out dimensions illustrated in Figure 2 are as follows:

MODELS	DIMENSIONS				
	A	B	C	D	E
SRNA3S SRSA3S	18 5/8"	16"	2"	20 5/8"	7/8"
SRNA3L SRSA3L	18 5/8"	21 3/4"	2"	20 5/8"	7/8"
SCN3/SCNA3 SCS3/SCSA3	18 5/8"	3 5/8"	2"	20 5/8"	7/8"

The minimum vertical distance to combustible material above the range cooking top is 24 inches, provided the overhead construction does not extend 13 inches from the rear wall.

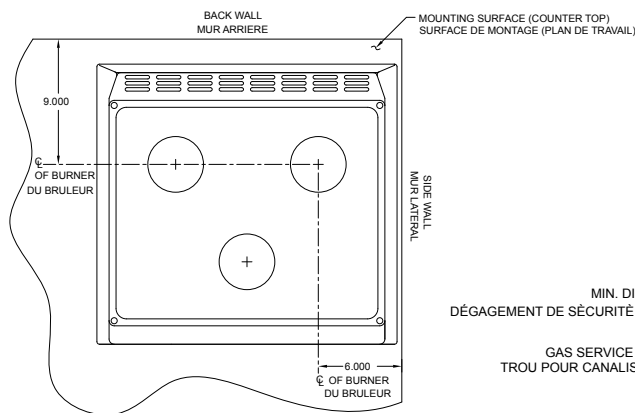

Figure 1A

NOTE: UL and cUL certified with a minimum top clearance of 19 1/2" to overhead combustible construction when installed with a range hood spaced a minimum of 1/4" from the construction.

- Ensure the cabinets are properly constructed. The cabinets must be squared with respect to the counter top and the cabinet face. For proper operation of these units, the cabinet must be level and the bottom of the range must be supported.
- After the cabinet has been prepared per the dimensions given and the gas connection is in place, remove main top and position the unit in the cabinet opening.

NOTE: Be sure all opening in the cabinetry around the gas lines are sealed at the time of installation.

WARNING! It is imperative that the cabinet in which the unit is placed be separated from other appliances so that the combustion air supply to the top burners can not be affected in any way by any forced-air heating appliance or its return air system or by any source of positive or negative air pressure, such as, but not limited to, power vents, fans, etc. A negative air pressure created by another forced air moving appliance may draw the flame down around the top burners and into the main top resulting in damage to the burners and cooktop, as well as possible personal injury and/or damage to vehicle. A positive draft could cause the burner flame to lift-off the burner and go out resulting in an uncontrolled escape of gas. Whenever the gas fumes reach an open flame or another ignition source, an explosion and/or fire will occur resulting in property damage, personal injury and/or loss of life.

- Fasten unit in place with wood screws through holes provided in side flanges of burner box and front frame bottom tabs with a minimum of six screws.
- Be sure burner knobs are in "off" position. Secure gas connection and turn on gas supply. Check all connections for leaks using soapy-water solution or a non-corrosive leak detection solution. Do not use a soapy-water solution containing ammonia.

CAUTION: Gas supply tubing within the confines of the appliance connection shall be rigid or semi-rigid metallic tubing.

WARNING! Never check for leaks with an open flame or any ignition source for this purpose.

NOTE: The appliance must be disconnected from the gas supply piping system during any pressure testing of that system at test pressure in excess of 1/2 PSIG.

- Replace main top.
- Your unit is now ready for operation. Before operating, read the safety information and operating instructions contained in the installation manual.

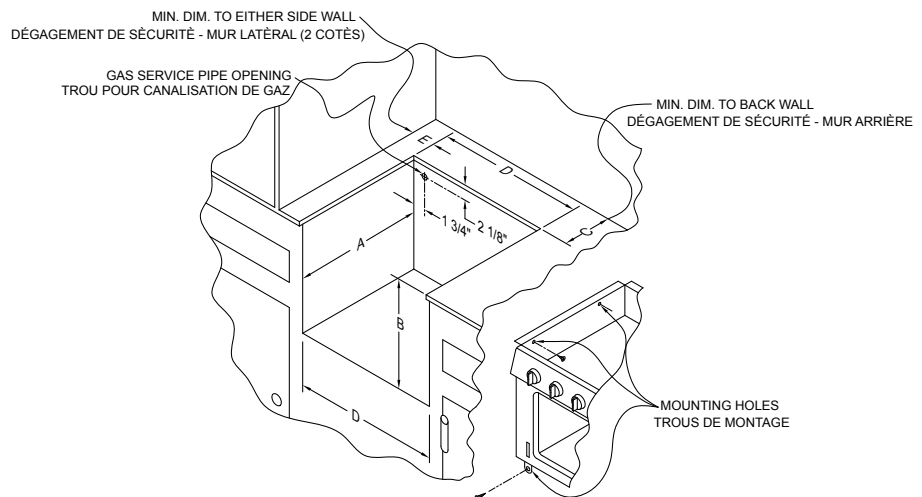

Figure 2

INSTALLATION INSTRUCTIONS

SDN2 • SDN3

WARNING! Installation of this appliance must be made in accordance with the written instructions provided in this manual. No agent, representative or employee of Suburban or other person has the authority to change, modify or waive any provision of the instructions contained in this manual.

- In the U.S.A., the installation must conform with state or other codes or in the absence of such codes, refer to the latest edition of:
 - Standard for Recreational Vehicles NFPA 1192.
 - National Fuel Gas Code ANSI Z223.1/NFPA 54
 In Canada, the installation must be in accordance with:
 - Standard CAN/CSA 240.4.2-08, Installation Requirements for Propane Appliances and Equipment in Recreational Vehicles.
 - Any applicable local codes and regulations
- Minimum clearances from combustible walls above and below counter:

MODELS	Center of Burner Head(s) to adjacent vertical combustible material above the cooking surface burners.			
	Below Counter Sides, Rear and Bottom	Right Sidewall	Left Sidewall	Backwall
SDN2	0"	5 7/8"	5 7/8"	8"
SDN3	0"	5 5/8"	6"	8"

- Cut-out dimensions illustrated in Figure 2 are as follows:

MODEL	DIMENSIONS				
	A	B	C*	D*	E
SDN2	16 3/8"	11 5/8"	2 3/16"	3/4" min.	18"
SDN3	18 15/16"	16 1/8"	2 1/16"	2 3/8" min.	21"

*Minimum acceptable spacing between adjacent models is 3 inches.

WARNING! Installation of cook top cannot be such that the user is required to reach over any of the burners to reach the knobs.

- Before placing drop-in cook top into cabinet, determine which one of the three knockout openings in the burner box (left side, right side or rear) will be used for routing of the gas supply tubing to the pressure regulator. After making selection, knockout the 1 inch plug. Place drop-in cook top into the prepared opening and secure to cabinet with four (4) wood screws. (Not provided)

NOTE: For models with a manifold extension, place the drop-in cook top into the prepared opening and secure to the cabinet with four (4) wood screws. (Not provided)

- Route gas line through opening in burner box and connect the gas line to the 3/8" flare fitting inside the burner box. Place nylon bushing over gas line and insert bushing into opening in burner box.

NOTE: For models with a manifold extension, connect the gas line to the 3/8" flare fitting just outside the burner box. Be sure to hold the fitting on the extension with a wrench when tightening the flare nut. Failure to hold fitting secure could result in a gas leak due to fitting being damaged.

CAUTION: Gas supply tubing within the confines of the appliance burner box shall be rigid or semirigid metallic tubing.

- Be sure all openings in the cabinets around the gas line are sealed at time of installation.

CAUTION: It is imperative that the cabinet in which the cook top is placed be separated from other appliances so that the combustion air supply to the top burners can not be affected in any way by any forced-air heating appliance or its return air system or by any other source of positive or negative air pressure. A negative air pressure created by another forced air appliance may draw the flame down around the top burners and into the cook top resulting in damage to the burners and cook top, as well as possible personal injury and/or damage to vehicle. A positive draft could cause the burner flame to lift-off the burner and go out resulting in an uncontrolled escape of gas. Whenever the gas fumes reach an open flame or another ignition source, an explosion and/or fire will occur resulting in property damage, personal injury and/or loss of life.

- Be sure burner knobs are in "off" position. Turn on gas supply. Check all connections for leaks.

WARNING! Never check for leaks with an open flame. Apply a soap and water solution to all joints to see if bubbles are formed.

NOTE: The appliance must be disconnected from the gas supply piping system during any pressure testing of that system at test pressure in excess of 1/2 PSIG.

- Remove the top and the grate(s) from their packing - Install the grate(s) on the top.
- Position the top over the burners and secure in place with two (2) thumb screws and two (2) nylon washers provided.
- Your Suburban Drop-in Cooktop is now ready for operation. Before operating, read the safety information and operating instructions contained in the installation manual.

11. If installation of this product is in a portable counter top, the following additional guidelines must be followed:

- Portable counter top is provided by installer and must be able to support a minimum weight of 20 lbs.
- OEM must provide a label placed on the counter top that clearly states the maximum weight that can be added to the portable counter top after installation. (This should take into account the weight of the cooking unit - 20 lbs).

FOR EXAMPLE: Mounting bracket used is rated for 100 lbs. OEM should weigh fabricated counter top. Subtract weight of counter top (i.e. 20 lbs) and weight of cooking unit (20 lbs.) from 100 lbs. The weight label should say no more than 60 lbs. can be put on the counter top.

- The surface material for the counter top must be rated for a minimum of 200°F continuous operation temperature with the maximum weight applied.
- Minimum clearances from combustible walls above and below the counter top must be adhered to during operation.
- The OEM must provide a warning label placed on the counter top that requires the unit to be cooled a minimum of 30 minutes after use before storing.
- During storage, a clearance of 1" must be maintained from the top surface of the unit.
- NOTE:** The gas must be turned "OFF" and disconnected when stored.

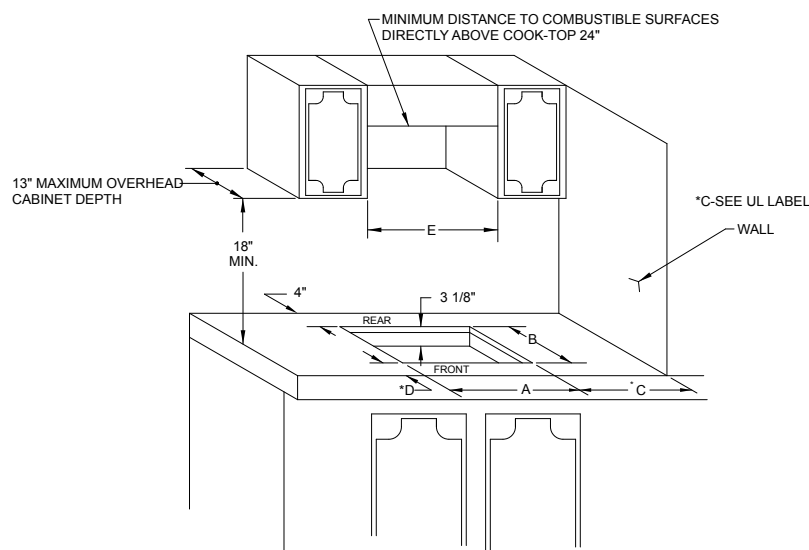

COOKING APPLIANCE TERMINOLOGY

TERMINOLOGY

DEFINITION

CSA	Canadian Standards Association – International
UL	Underwriters Laboratories
CUL	Underwriters Laboratories Canada
PILOT THERMOCOUPLE	A bimetal probe which generates a small electrical current when heat is applied to it
OVEN PILOT	The oven pilot burner that continually heats the thermocouple and furnishes the ignition source for the main oven burner.
BLOCK WITH MAIN BURNER ORIFICE	A precision drilled component that meters gas flow to the main burner.
MANIFOLD	A pressurized tube or pipe that provides gas to the top and oven burner valves.
OVEN THERMOSTAT	The control that regulates the temperature of the oven at the preferred cooking temperature and supplies gas for both the pilot burner and oven burner.
PIEZO IGNITER	An electromechanical device that can be used to ignite the top burners.
SPARK IGNITER	A battery operated device that can be used to ignite the top burner and oven pilot. (Requires 1 AAA battery)
REGULATOR	A valve that reduces the high propane tank pressure to the appropriate operating pressure that will serve the appliance.
THERMAL BULB	The bulb located in the oven attached to the thermostat containing thermal fluid and forces the thermostat to open and close based on the set cooking temperature.
YELLOW TIPPING	A burner flame with yellow tips caused by inaccurate gas/air mixture, incorrect placement or restriction of orifice and venturi tube.

MANIFOLD IDENTIFICATION

Sabaf (Round) Manifold with plug-in thermocouple

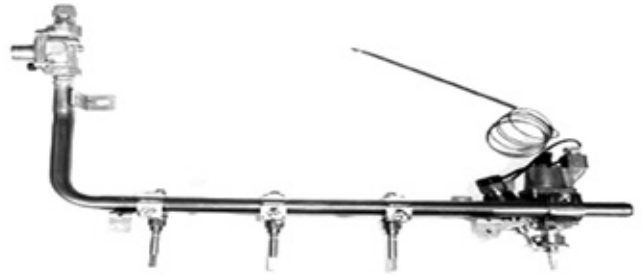
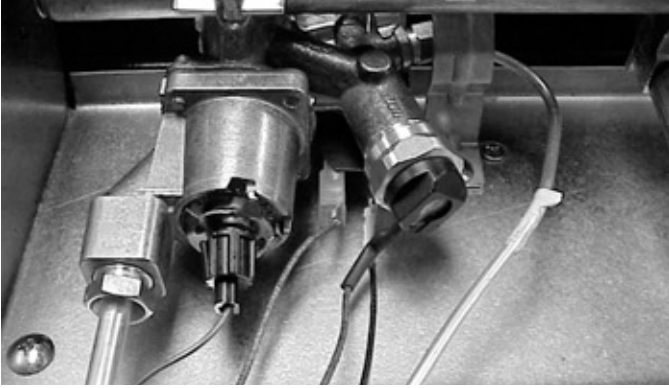

- Original mercury free system (Ranges with an A in the model number). Used exclusively in all Suburban mercury free ranges from 2004 through 2006.
- Used concurrently with the square manifold system (BSI) from late 2006 through early 2009.
- Since early 2009 the Sabaf manifold has been exclusively in sealed burner & glass top models ranges.
- Individual components available separately

BSI (Square) Manifold

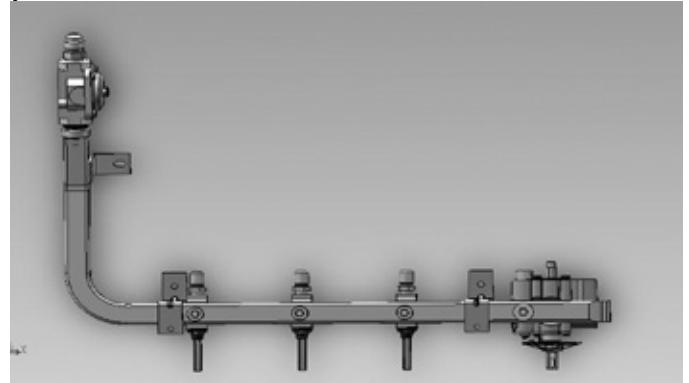
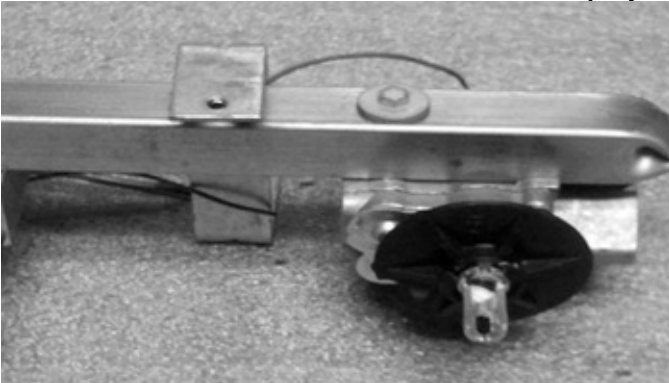

- First used in late 2006
- Used concurrently along with Sabaf manifolds (round) on all conventional burner model ranges from late 2006 through mid 2009
- Used exclusively on all conventional burner model ranges (N in the model number) from mid 2009 through mid 2011
- Used concurrently with Copreci manifold (round manifold with screw in style thermocouple) on all conventional burner model ranges from mid 2011 to present date
- All components only available as an assembly

Copreci Manifold (Round) Manifold With screw in thermocouple

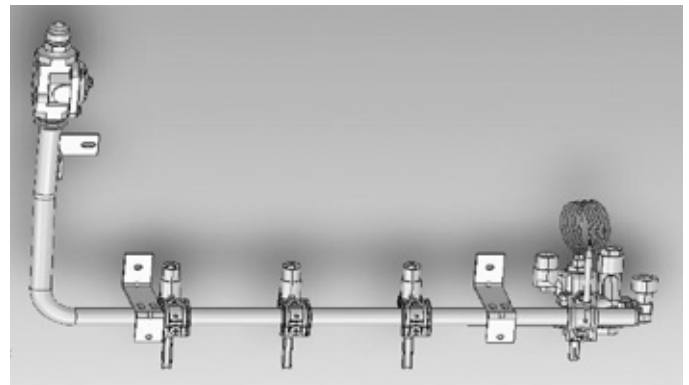
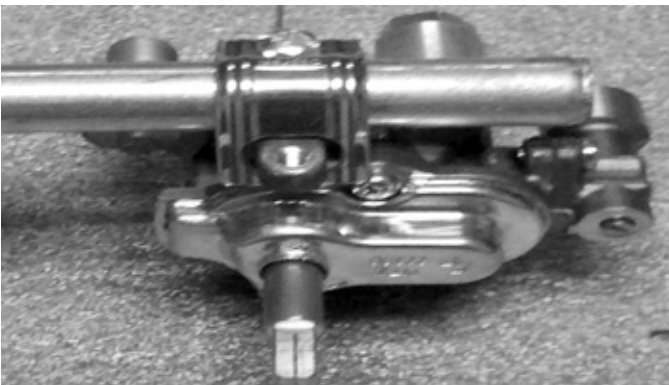

- Initial release in mid 2011
- Used concurrently with BSI on all conventional burner model ranges from January 2012 to present
- All components only available as an assembly

SUBURBAN TOP BURNER IDENTIFICATION INFORMATION

BSI

MUELLER

SI - CURRENT



In 2013, Suburban began a transition on stove top burners. All ranges currently have the low profile conventional burners (SI version).

The burners shown above must be replaced with respective burner. They are not backwards compatible. Review the Suburban parts manual or contact Customer Service at 423.775.2131 EXT 7101.

If a replacement is required for BSI style burner, you will need to order KIT# 521119 and replace all three burners.

TROUBLE SHOOTING GUIDE FOR SUBURBAN RANGES - OVEN -

PROBLEM	POSSIBLE CAUSE	CORRECTIVE ACTION
PILOT WON'T LIGHT	<p>A. Insufficient Gas Supply</p> <p>B. Insufficient Gas Pressure</p> <p>C. Restriction in pilot orifice or tubing</p>	<p>A. Inspect Gas Supply</p> <p>B. Check for gas leaks and correct gas pressure (11 W.C. - 14 W. C.</p> <p>C. Inspect and clean pilot orifice, inspect tubing for kinks or leaks around fittings.</p>
PILOT WON'T STAY LIT WHEN KNOB RELEASED	<p>A. Defective Thermocouple</p> <p>B. Pilot plunger inside gas control not fully engaged with magnet when knob is depressed</p> <p>C. Defective magnet in control thermostat</p> <p>D. Micro-switch not engaged (plug in thermocouple models only)</p>	<p>A. Inspect thermocouple connection, Inspect for proper flame impingement at thermocouple tip. Inspect mV output from thermocouple when heated (18 mV on screw in thermocouple) (4 mV. on plug in thermocouple)</p> <p>B. Inspect that knob is not coming in contact with range front when knob is depressed. This could keep pilot plunger inside gas valve from coming in contact with the electromagnet in valve. Inspect that plunger on valve is engaging when knob is depressed.</p> <p>C. Replace control valve/manifold assembly</p> <p>D. Inspect micro-switch, adjust as required.</p>
MAIN BURNER WON'T LIGHT	<p>A. No gas flowing to main burner</p>	<p>A. Inspect burner orifice for obstruction. Inspect gas pressure to main burner, replace oven control if defective. Ensure pilot is lit.</p>
MAIN BURNER FLUTTERS WHEN LIT	<p>A. Air Shutter incorrectly set</p> <p>B. Low gas pressure/restriction in orifice</p>	<p>A. Adjust air shutter on burner</p> <p>B. Inspect gas pressure and orifice. Adjust as required</p>
PILOT GOES OUT (STARTS POPPING) DURING BAKING CYCLE	<p>A. Pilot burner defective</p> <p>B. Gas control thermostat defective</p> <p>C. Pilot tubing restricted</p>	<p>A. Replace pilot burner</p> <p>B. Inspect gas pressure from gas control to pilot burner, replace gas control if found defective</p> <p>C. Inspect pilot tubing for kinks or leaks at connections</p>
POOR BAKING RESULTS - Food too light or too dark - Food cooks unevenly	<p>A. Oven not preheated</p> <p>B. Poor oven air circulation</p> <p>C. Oven temperature sensing bulb not installed correctly</p> <p>D. Thermostat out of calibration</p>	<p>A. Preheat oven a minimum of 10 minutes</p> <p>B. Inspect to ensure that oven vent is not blocked or that oven is too full for proper air circulation</p> <p>C. Inspect that bulb is installed into clip located at the top of cooking compartment</p> <p>D. Have range inspected by qualified service technician. Replace thermostat manifold assembly if found to be defective.</p>

TROUBLE SHOOTING GUIDE FOR SUBURBAN RANGES - RANGE ASSEMBLY -

PROBLEM	POSSIBLE CAUSE	CORRECTIVE ACTION
OVEN DOOR WON'T STAY CLOSED	<p>A. Hinge spring too loose (sprung)</p> <p>B. Hinge foot not properly installed into oven front frame</p>	<p>A. Replace door hinge assemblies</p> <p>B. Inspect hinge foot connection to oven frame, adjust as required by lifting door from bottom and gently pulling door forward to allow notch in hinge foot to catch on the bottom of the slot on the front frame</p>
RANGE TOP WON'T STAY LATCHED	<p>A. Latch is improperly adjusted</p> <p>B. Range installed incorrectly, underside of top hits counter top before latch catches</p>	<p>A. Inspect and adjust top latch accordingly</p> <p>B. Correct installation so that range top rests evenly on burner box and counter top with latch caught on control panel</p>

- SLIDE-IN AND DROP-IN COOK TOP -

PROBLEM	POSSIBLE CAUSE	CORRECTIVE ACTION
BURNER WON'T LIGHT	<p>A. Clogged burner port(s)</p> <p>B. Insufficient gas pressure</p>	<p>A. Clean ports with a small wire or pin. Be sure not to enlarge ports. Never use a wire brush which may "shed" bristles which may become lodged in the orifice or burner ports and cause a fire or explosion</p> <p>B. Inspect propane supply, inspect for gas leaks, have propane pressure inspected by a qualified service technician</p>
BURNER WON'T LIGHT WITH PIEZO (SLIDE-IN ONLY)	<p>A. Improper installation</p> <p>B. Defective electrode in burner</p> <p>C. Defective Piezo</p>	<p>A. Inspect Piezo wire connections at electrodes and Piezo for proper installation</p> <p>B. Inspect electrode for spark. Replace burner if defective</p> <p>C. Inspect Piezo. Replace if defective</p>
BURNER FLAME IS UNEVEN OR TOO SMALL	<p>A. Clogged burner port</p> <p>B. Insufficient gas pressure</p>	<p>A. Clean ports with a small wire or pin. Be sure not to enlarge ports</p> <p>B. Inspect propane supply, inspect for gas leaks, have propane pressure inspected by a qualified service technician (11" W.C. - 14" W.C.)</p>
FLAME LIFTS OFF BURNER	<p>A. Propane pressure too high</p>	<p>A. Inspect propane supply, inspect for gas leaks, have propane pressure inspected by a qualified service technician (11" W.C. - 14" W.C.)</p>
YELLOW FLAME (SEALED BURNER MODELS)	<p>A. Burner tube to orifice holder alignment incorrect (sealed burner models only)</p>	<p>A. Inspect orifice holder mounting bracket for proper positioning in relation to the burner tube</p>

OPERATING INSTRUCTIONS

A. TOP BURNERS

1. Know which knob controls which burner. Always be sure the correct burner is turned on.
2. Depress knob and turn counter-clockwise to "Lite" position.
 - a. Verify sufficient gas supply before attempting to light the burner. Air in the gas line will significantly delay burner ignition. The burner may light unexpectedly as the air in the line clears and is replaced by LP gas. This unexpected ignition could burn you. Air in the gas lines may occur after the vehicle gas bottle and/or tank is refilled, during and after servicing other appliances on same gas line, etc.
 - b. Do not attempt to light more than one burner at a time.
 - c. Immediately light burner on those models ending with "M" (example: SRNA3LWBM; SRSA3SWBM). Hold a long match near the burner ports.

CAUTION: Hand held igniters may be used but be sure they are the type designed for lighting open flame burners.

If your model ends with "E" (example: SRNA3LWBE / SRSA3SWBE), the burner can be lit by rotating piezo knob clockwise rapidly. Also, if your model ends with an "S" (example: SRNA3SPSS / SRSA3SPSS) the burner can be lit by depressing the push button battery powered spark igniter located at the left hand side of the control panel, both of these igniter systems will produce a spark at the top burners which ignites the gas.

3. If any burner should extinguish after initial lighting or due to accidental blowout, turn gas off by turning control knob clockwise to "OFF", wait five (5) minutes before attempting to relight the burner. Failure to follow these instructions could result in a fire or explosion. If the burner should go out while cooking, or if there is an odor of gas, turn control knob(s) clockwise to "OFF". Wait five (5) minutes for gas odor to disappear. If gas odor is still present - do not relight burners.
4. To turn burner(s) "OFF", turn the appropriate control knob clockwise to "OFF".

WARNING! Be sure all control knobs are turned "OFF" when you are not cooking. Someone could be burned or a fire could start if a burner is accidentally left on or unattended even if only momentarily

B. OVEN OPERATING INSTRUCTIONS

NOTE: Before the oven burner will operate, the oven pilot must be lit.

1. Lighting Oven Pilot:

- a. Be sure ALL valves are in the "OFF" position. The oven control knob should be in the "OFF" position.
- b. Be sure main gas supply is on.
- c. Open oven door; smell for gas - If you smell gas STOP! Read and follow the instructions as listed in the appliances installation manual.
- d. If you do not smell gas, turn knob to the pilot position, "Push In/Lite Pilot".
- e. Immediately light pilot with a match. Hold knob in at least 5 to 7 seconds to allow gas to flow to pilot and to heat thermocouple. Release knob, pilot should stay on. Note: If the appliance has not been operated for a long period of time, a longer waiting period for ignition of the pilot may be due to air in the pilot and gas lines. If pilot goes out, repeat steps a, b, c, d.

2. Operation of the Oven Burner

- a. Turn the oven control knob counter-clockwise to the desired setting. Oven burner will come on immediately and the oven burner will stay on until it reaches the desired setting. Then the oven burner flame will decrease in size. This is normal for this type of thermostat and this flame size will maintain a constant temperature within the oven.

NOTE: Oven thermostat was calibrated at the factory and is not field adjustable.

3. To Shut Off Oven Burner:

- a. Turn oven control knob clockwise to "Pilot On" position.

At this position, the oven pilot will remain lit.

4. To Shut Off Oven Pilot:

- a. Slightly depress knob and turn to "OFF". At this position, the oven pilot will go out.

RANGE DOOR REMOVAL INSTRUCTIONS

To remove the oven door from the range, open the oven door to approximately 45° from the closed position, and then place 2 pins (6d finish nail) through the aligned holes in the hinge claw and the hinge link. Allow the door to move towards the closed position and rest with the hinges locked open by the pins, the door will remain approximately 30° open. Lift the door up and in towards the range, this will allow the hinge arms to come out of through the hinge slots in the front frame of the oven.

To reinstall the door, insert the hinge arms in through the hinge slots on the front frame. Allow the hinge to rest on the bottom edge of the hinge slot on the front frame. Open the door to approximately 45° and remove the pins from the hinge arms then allow the door to close.



LIMITED WARRANTY

SUBURBAN RECREATIONAL VEHICLE COOKING APPLIANCE

TWO YEAR LIMITED WARRANTY

This Suburban product is warranted to the original purchaser to be free from defects in material and workmanship under normal use and maintenance for a period of two years from date of purchase whether or not actual use begins on that date. All porcelain parts, including top burner grates, are warranted as commercially acceptable only as of the date the product was manufactured. It is the responsibility of the consumer/owner to establish the warranty period. Suburban does not use warranty registration cards for its standard warranty. You are required to furnish proof of purchase date through a Bill of Sale or other payment records.

Suburban will replace any parts that are found defective within the first two years and will pay a warranty service allowance directly to the recommended Suburban Service Center at rates mutually agreed upon between Suburban and its recommended service centers. Replacement parts will be shipped FOB the shipping point within the Continental United States, Alaska and Canada to the recommended service center performing such repairs. All freight, shipping and delivery costs shall be the responsibility of the owner. The exchanged part or unit will be warranted for only the unexpired portion of the original warranty. Before having warranty repairs made, confirm that the service agency is a recommended service center for Suburban. **DO NOT PAY THE SERVICE AGENCY FOR WARRANTY REPAIRS; SUCH PAYMENTS WILL NOT BE REIMBURSED.**

Suburban reserves the right to examine the alleged defect in the range appliance or component parts, and it is the owner's obligation to return the range appliance and/or component parts to Suburban or its representative. When returning a range appliance, it must include all component parts and the serial number plate. Returned component parts must be individually tagged and identified with the range appliance's model number, serial number and date of installation.

For warranty service, the owner/user should contact the nearest recommended Suburban Service Center, advising them of the model and serial numbers (located underneath the main top) and the nature of the defect. Transportation of the RV to and from the Service Center and/or travel expenses of the Service Center to your location is the responsibility of the owner/user. A current listing of recommended service center may be obtained from Suburban's website: www.AIRXCEL.com. If you cannot locate a recommended service center locally, the service agency chosen to perform warranty repairs must contact our Service Department at 423-775-2131 for authorization before making repairs. Unauthorized repairs made will not be paid by Suburban.

LIMITATION OF WARRANTIES

ALL IMPLIED WARRANTIES (INCLUDING IMPLIED WARRANTIES OF MERCHANTABILITY) ARE HEREBY LIMITED IN DURATION TO THE PERIOD FOR WHICH EACH LIMITED WARRANTY IS GIVEN. SOME STATES DO NOT ALLOW LIMITATIONS ON HOW LONG AN IMPLIED WARRANTY LASTS SO THE ABOVE LIMITATIONS MAY NOT APPLY TO YOU. THE EXPRESSED WARRANTIES MADE IN THIS WARRANTY ARE EXCLUSIVE AND MAY NOT BE ALTERED, ENLARGED, OR CHANGED BY ANY DISTRIBUTOR, DEALER OR OTHER PERSON WHOMSOEVER.

SUBURBAN WILL NOT BE RESPONSIBLE FOR:

1. Normal maintenance as outlined in the installation, operating and service instructions owner's manual including cleaning of component parts and cleaning or replacement of the burner orifice.
2. Initial checkouts and subsequent checkouts which indicate the range appliance is operating properly, or diagnosis without repair.
3. Damage or repairs required as a consequence of faulty or incorrect installation or application not in conformance with Suburban instructions.
4. Any damage (cracks, chips, scratches, etc.) to any painted or porcelain enamel parts.
5. Failure to operate due to loose or disconnected wires; water or dirt in controls, fuel lines and gas tanks; improper gas pressure; low voltage.
6. Cleaning or adjustment of components; electrode, burner tube, pilot and thermocouple.
7. Costs incurred in gaining access to the range appliance.
8. Parts or accessories not supplied by Suburban.
9. Freight charges incurred from parts replacements.
10. Damage or repairs needed as a consequence of any misapplication, abuse, unreasonable use, unauthorized alteration, improper service, improper operation or failure to provide reasonable and necessary maintenance.
11. Suburban products whose serial number has been altered, defaced or removed.
12. Suburban products installed or warranty claims originating outside the Continental U.S.A., Alaska, Hawaii and Canada.
13. Damage as a result of floods, winds, lightning, accidents, corrosive atmosphere or other conditions beyond the control of Suburban.
14. Any special, indirect or consequential property, economic or commercial damage of any nature whatsoever. Some states do not allow the exclusion of incidental or consequential damages, so the above limitation may not apply to you.

NO REPRESENTATIVE, DEALER, RECOMMENDED SERVICE CENTER OR OTHER PERSON IS AUTHORIZED TO ASSUME FOR SUBURBAN MANUFACTURING COMPANY ANY ADDITIONAL, DIFFERENT OR OTHER LIABILITY IN CONNECTION WITH THE SALE OF THIS SUBURBAN PRODUCT.

This warranty gives you specific legal rights, and you may also have other rights which vary from state to state.

IF YOU HAVE A PRODUCT PROBLEM

FIRST:

If your RV has its original range appliance and is still under the RV manufacturer's warranty, follow the steps suggested by your dealer or manufacturer of the RV.

SECOND:

Contact a conveniently located recommended Suburban Service Center. Describe to them the nature of your problem, make an appointment, if necessary, and provide for delivery of your RV to the selected service center.

THIRD:

To obtain information on locating a local service agency, contact:
AIRXCEL, Inc., Suburban Division
Customer Service Department
676 Broadway Street
Dayton, Tennessee 37321
(423) 775-2131, Ext. 7101
www.AIRXCEL.com

FOR FUTURE REFERENCE, YOU SHOULD RECORD THE FOLLOWING INFORMATION:

MODEL NUMBER:	_____
SERIAL NUMBER:	_____
STOCK NUMBER:	_____
DATE OF PURCHASE:	_____



676 Broadway Street • Dayton, Tennessee 37321

Phone: 423-775-2131 • Fax: 423-775-7015

www.AIRXCEL.com

All information published in this manual is subject to change without notice.

2015 CASTM

04-14-2015