

# Solid State Headlight Flasher with Select-A-Pattern Technology (ETHFSS-SP)

(ETHFSS-SPA) with AMP Connector  
(ETHFSS-SPFL) with AMP Connector, Mating Harness, and Loop Plug

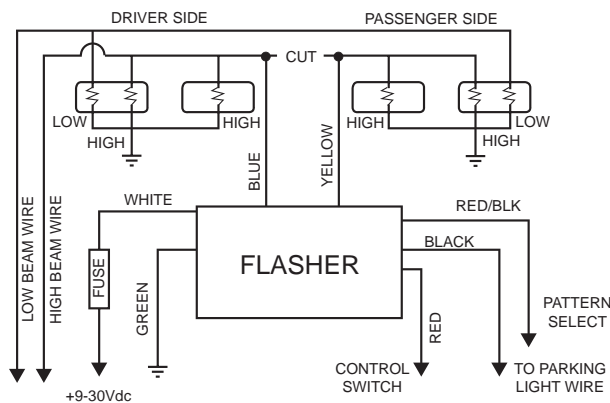

## 4 LAMP INSTALLATION

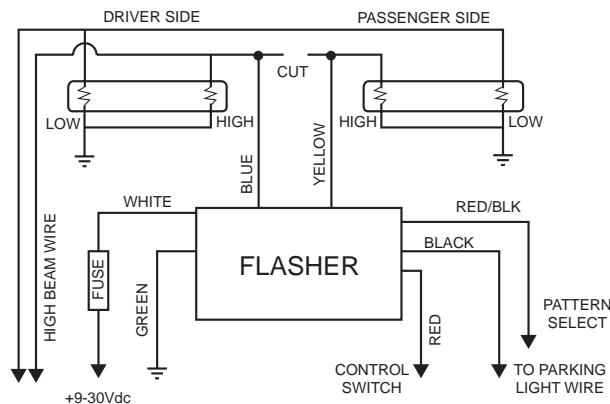

## 2 LAMP INSTALLATION

Please see reverse for Technical Specifications



Congratulations! You are now the proud owner of the most technically advanced true 100% Solid State Selectable Pattern Headlight Flasher System in the market today. Add to it our never ending commitment to quality, when properly installed this new Flasher System will provide you with years of dependable trouble free service.

The Flasher System will operate a 2 or 4 headlight system on any vehicle with a +8-30 Vdc negative ground system.

**NOTE:**  
When used in dark conditions, the low beam headlights need to be ON for proper illumination, while the highbeam headlights will flash to gain attention and increase the vehicle's visibility.

When the high beam switch is activated, the Flasher system's High Beam Over-Ride (HBOR) is activated and will interrupt the flashing sequence to allow normal high beam function. The HBOR function is automatically disabled with the high beam switch is de-activated allowing the headlight flasher to resume operation.

**NOTE:**  
Flashing Headlights and Taillight Systems are intended for approved vehicles only. The user of this system is responsible to ensure compliance to any Federal, State, or Municipal regulations, which may apply.

**WARNING:**  
This Flasher will not work on any "ground side switched" system. If you have any questions regarding what type of system your vehicle has, contact SoundOff Signal's Technical Service Department at 1-800-338-7337.

## MOUNTING:

The enclosed headlight flasher has been designed to be water resistant. However, to ensure years of trouble free operation of the flasher system, it should be mounted in a location that is protected from direct water spray and high temperatures.

**GREEN WIRE:**  
Connect to reliable ground, preferably close to ground post of battery

**BLUE and YELLOW WIRES:**  
Locate the wire that supplies power to either the passenger side or driver side high beam headlight. Cut this wire approximately 10-12" from the headlight. Connect the yellow wire to the lead that returns to the headlight. Connect the blue wire to the other piece of the cut wire which will provide power to the opposite highbeam headlight.

**WHITE WIRE:**  
Connect to a +8-30 Vdc power source capable of providing 15 Amps.

**WARNING:**  
**DO NOT USE A CIRCUIT BREAKER, FUSIBLE LINK, OR SLOW BLOW TYPE FUSE**

**RED WIRE:**  
Connect to a powered switch through a user supplied 1 amp fuse.

**BLACK WIRE (OPTIONAL Connection):**  
If an "Automatic Nighttime Flasher disable" is required (check with state and municipal regulations) simply 'T' or tap this wire into the parking / marker light wire. This feature will disable the flasher whenever the parking / marker lights are turned ON.

To review our Limited Warranty Statement & Return Policy for this or any SoundOff Signal product please visit our website at [www.soundoffsignal.com](http://www.soundoffsignal.com) and select the "Warranty & Returns" link along the left column of our home page. If you have questions regarding this product please contact Technical Services, Monday - Friday, 8 am to 5 pm at 1.800.338.7337, press #4 to skip the automated message. Questions or comments that do not require immediate attention may be emailed to [techsupport@soundoffsignal.com](mailto:techsupport@soundoffsignal.com).

1.800.338.7337. / [www.soundoffsignal.com](http://www.soundoffsignal.com) / Thank you for trusting us with your safety!

**Solid State Headlight Flasher with Select-A-Pattern Technology (ETHFSS-SP) (ETHFSS-SPA) with AMP Connector (ETHFSS-SPFL) with AMP Connector, Mating Harness, and Loop Plug**

ELECTRICAL SPECIFICATIONS	
Input Voltage	8-30Vdc
Output Current:	9.5 Amps / output
Standby Current:	< 10mA
Number of Flash Patterns:	7

Flash Patterns	
Flash Pattern Sequence	FPM (Flashes per Minute)
1. RoadRunner™	115
2. PowerPulse™	180
3. ETM™	215
4. Double Flash	50
5. Q-Switch™	Multi-Pattern
6. Cycle Flash	Multi-Pattern
7. Single Flash	56

**Final System Check:**

1. Verify Headlight Flasher properly flashes headlights when Flash Enable switch is turned ON.
2. With Flash Enable Switch ON, turn High beam switch ON and verify both high beam headlights turn ON steady.
3. If NTCO is required: With Flash Enable Switch ON, turn parking / marker lights ON and verify Flasher does not function.

**Troubleshooting:**

**Symptom:**

No Operation

Interference with Radio equipment

Flasher stops functioning when marker lights are turned ON

Headlights turn ON for short time then OFF for a couple of seconds and repeats

**Solution:**

Verify fuse is not open. Verify voltage of 8-30Vdc is present on RED WIRE and Flash enable wire.

Verify power and ground wires are not connected to same circuit as radio equipment. Connect ground wire as close to ground terminal of battery as practical

NTCO (Night Time cut-off) wire is connected to parking / marker lights. If flashing of headlights is allowed at night, remove NTCO wire from marker light wiring.

Over-current shutdown of the flasher has detected too much load on the flasher. Verify a maximum of 2-55 Watt lamps are connected to each output

**Flash Pattern Selection:**

To change the pattern, momentarily touch RED/BLK WIRE to ground. The pattern will change each time RED/BLK WIRE is touched to ground.

Once the pattern is selected, the flasher will retain the selected flash pattern.

