

bluePRINT[®]

CENTRAL CONTROLLER
PART NUMBER: ENGCC01241

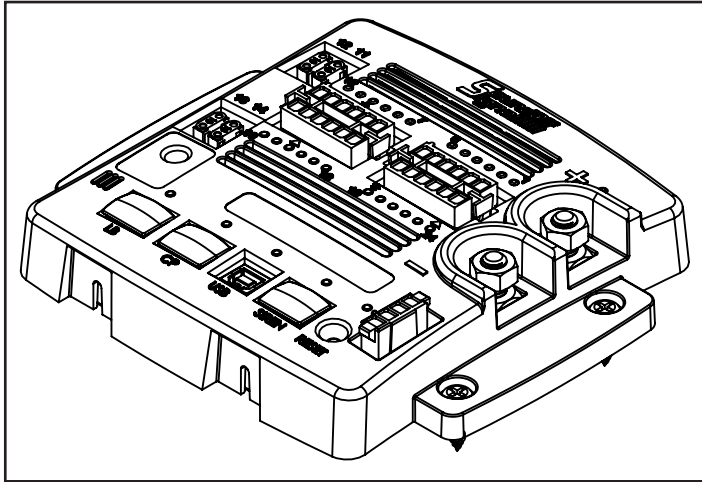

⚠ WARNING

- HIGH CURRENT interconnects must be properly terminated. Poor crimp quality can cause heat build-up and fire. Follow crimp connector manufacturer instructions.
- DO NOT install this product or route any wires in the Air Bag Deployment Zone. Refer to vehicle Owner's Manual for deployment zones.
- Do NOT use system to disconnect headlights, brake lights or other safety equipment.
- Unit may become hot to touch during normal operation.
- Failure to properly install connectors, fuses or wiring may cause vehicle failure or fire.
- Installation must only be performed by trained technician. Installer must determine vehicle wiring configuration and proper integration of system.
- Use proper wire gauge. All power wires connecting to positive (+) or negative (-) battery terminal or local chassis ground (-) must be sized to supply at least 125% of max. current and properly fused at power source.
- Install protective grommets when routing wire through firewall or metal.

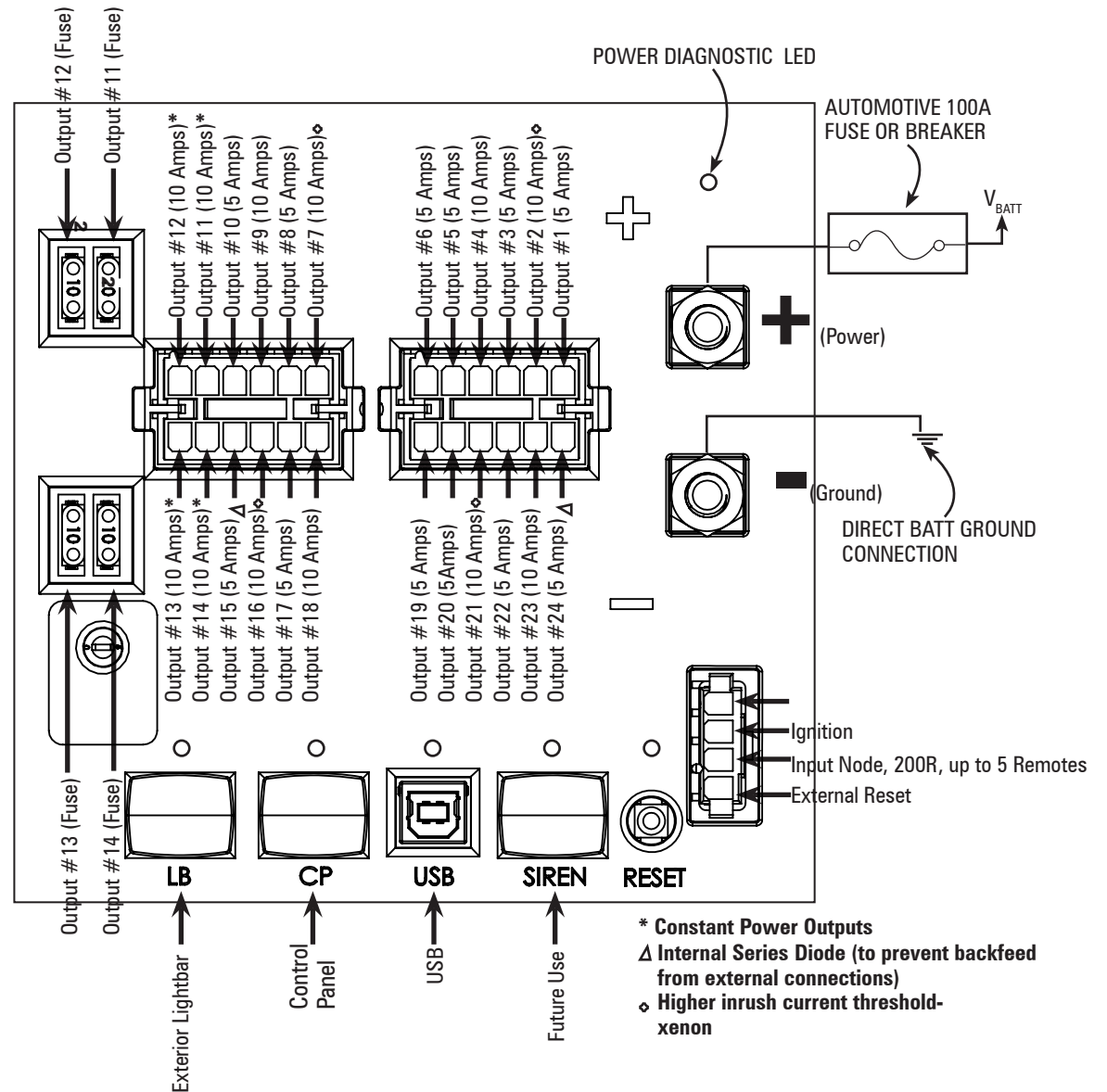

NOTICE:

Installers and users must comply with all applicable federal, state and local laws regarding use and installation of warning devices.

Improper use or installation may void warranty coverage.

To review our Limited Warranty Statement & Return Policy for this or any SoundOff Signal product, visit our website at www.soundoffsignal.com/tech-services/returns/.

If you have questions regarding this product, contact **Technical Services**, Monday - Friday, 8 a.m. to 5 p.m. ET at 1.800.338.7337 (press #4).

Questions or comments that do not require immediate attention may be emailed to techservices@soundoffsignal.com.

SoundOff Signal

1.800.338.7337 / www.soundoffsignal.com



CENTRAL CONTROLLER PART NUMBER: ENGCC01241

⚠ WARNING

- Install fuse or breaker (100Amps max.) on main power supply.
- Do NOT connect product to strobe power supply. Product is self-contained; no external power supply needed.
- Follow attached Wiring and Interconnect requirements.
- **Torque the provided M8 nuts with lock washer to a maximum of 7ft-lbs.**
-Verify that the lockwasher is fully seated when assembled-

The Central Controller processor stores and interprets the input and output configuration from the software application and control outputs accordingly as well as monitors outputs for fault conditions. The Central Controller is fully software configurable via PC Software app through USB connection.

The central controller is the communication hub for other system components within the EV Control System allowing for:

- A communication port for lightbar
- A communication port for 14 button control panel
- A communication port for other control system devices
 - Up to 5 remote nodes
 - Input node
 - Up to 2 200R siren amplifiers

The central controller allows for 24 outputs for connection to vehicle devices (100 Amps max) and has:

- (4) 10-amp fused outputs - constant power [outputs 11-14]
- (8) 10-amp solid state switchable outputs
- (12) 5-amp solid state switchable outputs

Multi-color lights should be driven by outputs within the same output group (Group 1: 1-5, Group 2: 6-10, Group 3: 15-19, Group 4:20-24) to align timing.

DIAGNOSTIC LED

- Power LED is steady on when the device is powered up and running with no errors.
- Power LED is off when the device is off or in sleep mode.
- Power LED winks when there is a system fault.
 - Fault condition is read by counting the number of times the LED “winks” on. Each fault condition will generate a pattern where each wink is 250ms on/250ms off. The pattern is terminated by the LED being off for 2.5 seconds.
 - *The LED will wink multiple patterns when more than one fault condition is active.

Tech Specs	bluePRINT® Control System Central Controller
Input Voltage:	10-16Vdc (Negative Ground)
Maximum Load Current:	100 Amps
Outputs (Sum of ALL used Outputs Shall Not Exceed 100Amps)	4x 10Amp Fused Battery 8x 10Amp Solid State, Switched 12x 5Amp Solid State, Switched
IGN ON: Standby Current:	140mA
IGN OFF: Sleep Current:	0.34mA
Inputs:	1x Ignition Input Active High
Reverse Polarity Protection:	Not Protected (Reverse Polarity will Destroy the Devices)
Transient Protection:	Protected
High Voltage Protection:	> 16V; High Voltage Error Code Set
Low Voltage Protection:	< 9V; Low Voltage Error Code Set
Operating Temp:	-40 °C to + 65 °C
Dimensions:	7" x 6.25" x 1"
Weight, Boxed:	1 lb. 7 oz.
Weight, Device Only:	14.9 oz.
Valid Integration Threshold - High	> 8.5V
The Central Controller is not waterproof. Install in a protected location away from excessive heat and moisture.	

Fault Condition Wink Patterns:

- 1 Wink - CPDU output(s) are faulted
- 2 Winks - Communication Fault
- 3 Winks - Source voltage level is < 9 VDC
- 4 Winks - Source voltage level is > 16VDC
- 5 Winks - Over temperature condition
- 6 Winks - RPDU output(s) are faulted
- 7 Winks - Invalid/Blank configuration loaded

See attached Install Template to aid in connections and programming

NOTICE:

Installers and users must comply with all applicable federal, state and local laws regarding use and installation of warning devices.

Improper use or installation may void warranty coverage.

To review our Limited Warranty Statement & Return Policy for this or any SoundOff Signal product, visit our website at www.soundoffsignal.com/tech-services/returns/.

If you have questions regarding this product, contact **Technical Services**, Monday - Friday, 8 a.m. to 5 p.m. ET at 1.800.338.7337 (press #4).

Questions or comments that do not require immediate attention may be emailed to techservices@soundoffsignal.com.







1.800.338.7337 / www.soundoffsignal.com

Wiring and Interconnect Requirements for ENGCC01241 Central Controller

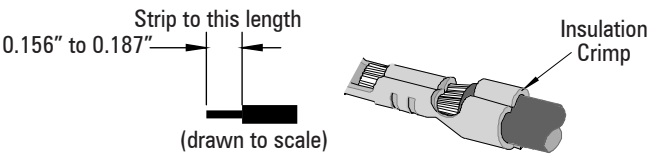
! WARNING

- High current interconnects require careful termination with the proper equipment. **WARNING! Poor crimp quality can cause significant heat build-up possible safety concerns.** Connector manufacturers provide instructions on how to terminate properly in order to have a safe and reliable connection.
- Central Controller can switch up to a **total maximum of 100Amps**. User must configure outputs to not exceed this total current. Individual output switches are rated up to 10Amps each for higher current loads, **but the total device current must not exceed 100Amps including the (4) constant on outputs**. The software warns when these limits are exceeded and user must ensure that individual output limits and total device current limits are not exceeded in normal use.
- **Do not gang or parallel multiple outputs to drive a high current load.** Multiple 5Amp and 10Amp outputs must not be combined to achieve a higher current limit.

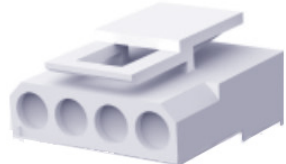
TERMINATION OPTION 1	
Purchase accessory mating harness from SoundOff Signal	
SoundOff P/N: ENGHNK01 – Two 12pin Mating Harnesses and one 4pin Mating Harness (18 inches) ENGHNK04 – Two 12pin Mating Harnesses and one 4pin Mating Harness (15 foot)	
	
Pros:	• No need to terminate at the connector pins
Cons:	• Requires butt-splice or alternate connector
	

TERMINATION OPTION 2		
Purchase individual connector components to terminate the wires at the connector.		
TE (AMP) P/N: 1-480287-0	TE (AMP) P/N: 1-480772-0	TE (AMP) P/N: 350557-4
		
16pin Commercial MATE-N-LOK Receptacle	4pin Commercial MATE-N-LOK Receptacle	Commercial MATE-N-LOK Socket Terminal (16-18 AWG wire, used with both receptacles)
<ul style="list-style-type: none"> • Application Specification 114-1012: http://www.te.com/commerce/DocumentDelivery/DDEController?Action=showdoc&DocId=Specification+Or+Standard%7F114-1012%7FE%7Fpdf%7FEnglish%7FENG_SS_114-1012_E.pdf%7F350557-4 • PRO-CRIMPER III FRAME 354940-1: http://www.te.com/catalog/pn/en/354940-1?RQPN=354940-1 • DIE ASSY: 90575-2: http://www.te.com/catalog/pn/en/90575-2?RQPN=90575-2 • Actual terminal and housing needs may be different depending on application, wire type, etc. • Extraction tool 1-305183-2: http://www.te.com/catalog/pn/en/1-305183-2?RQPN=1-305183-2 		
Pros:	• Consistent wire colors, clean install without butt-splices	
Cons:	• Need to purchase crimper and train personnel	

NOTICE:

Installers and users must comply with all applicable federal, state and local laws regarding use and installation of warning devices.

Improper use or installation may void warranty coverage.

To review our Limited Warranty Statement & Return Policy for this or any SoundOff Signal product, visit our website at www.soundoffsignal.com/tech-services/returns/.

If you have questions regarding this product, contact **Technical Services**, Monday - Friday, 8 a.m. to 5 p.m. ET at 1.800.338.7337 (press #4).

Questions or comments that do not require immediate attention may be emailed to techservices@soundoffsignal.com.



1.800.338.7337 / www.soundoffsignal.com

ENHANCING SAFETY THROUGH INNOVATION

bluePRINT[®]

**CENTRAL CONTROLLER
INSTALL TEMPLATE**

Department: _____
 Vehicle: _____
 Installer / Date: _____
 Mounting Location: _____

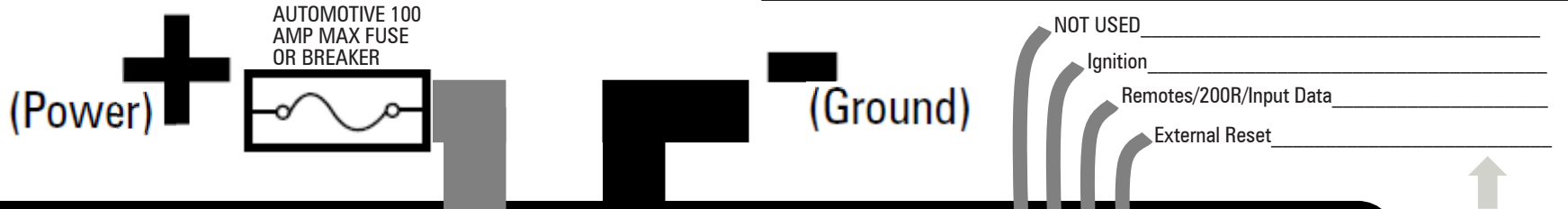

Wire Color ↓
 Function ↓

Function ↓
 Wire Color ↓

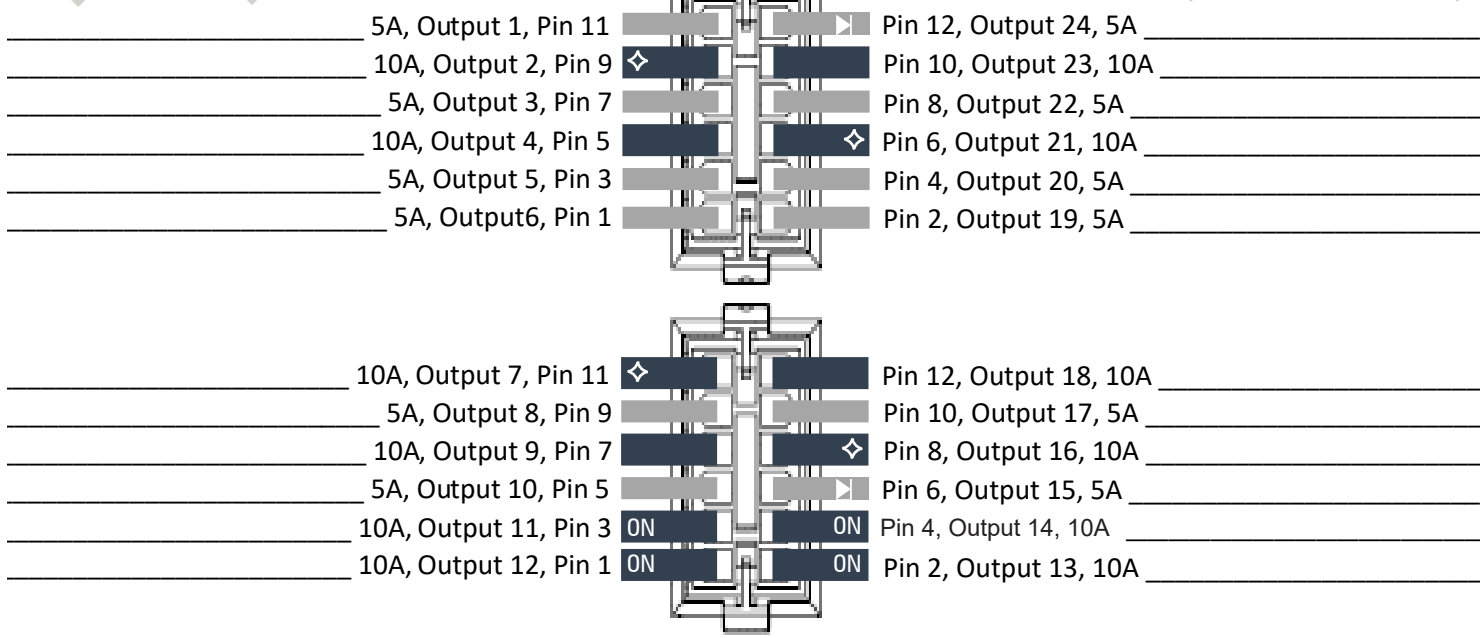

Always On, Output 11, 10A
 Always On, Output 12, 10A

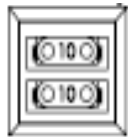
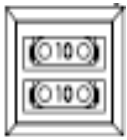

Always On, Output 14, 10A
 Always On, Output 13, 10A

↑ Wire Color

Serial:
480 Siren Amp

USB for
configuration &
diagnostics only

Serial:
Control Panel

Serial:
Lightbar

▶ = Backfeed Protection ◊ = Xenon Inrush