

SHARP SERVICE MANUAL

S5405R820JPS/

DOUBLE GRILL CONVECTION MICROWAVE OVEN



MODEL **R-820JS**

In the interest of user-safety the oven should be restored to its original condition and only parts identical to those specified should be used.

WARNING TO SERVICE PERSONNEL: Microwave ovens contain circuitry capable of producing very high voltage and current, contact with following parts may result in a severe, possibly fatal, electrical shock. (High Voltage Capacitor, High Voltage Power Transformer, Magnetron, High Voltage Rectifier Assembly, High Voltage Harness etc..)

TABLE OF CONTENTS

	Page
PRECAUTIONS TO BE OBSERVED BEFORE AND DURING SERVICING TO AVOID POSSIBLE EXPOSURE TO EXCESSIVE MICROWAVE ENERGY	INSIDE FRONT COVER
BEFORE SERVICING	INSIDE FRONT COVER
WARNING TO SERVICE PERSONNEL	1
MICROWAVE MEASUREMENT PROCEDURE	2
FOREWORD AND WARNING	3
PRODUCT SPECIFICATIONS	4
GENERAL INFORMATION	4
OPERATION	6
TROUBLESHOOTING GUIDE	13
TEST PROCEDURE	15
TOUCH CONTROL PANEL	23
COMPONENT REPLACEMENT AND ADJUSTMENT PROCEDURE	30
PICTORIAL DIAGRAM	37
POWER UNIT CIRCUIT	38
CPU UNIT CIRCUIT	39
PRINTED WIRING BOARD	40
PARTS LIST	41
PACKING AND ACCESSORIES	43

SHARP CORPORATION

This document has been published to be used for after sales service only.

The contents are subject to change without notice.

PRECAUTIONS TO BE OBSERVED BEFORE AND DURING SERVICING TO AVOID POSSIBLE EXPOSURE TO EXCESSIVE MICROWAVE ENERGY

- (a) Do not operate or allow the oven to be operated with the door open.
- (b) Make the following safety checks on all ovens to be serviced before activating the magnetron or other microwave source, and make repairs as necessary: (1) interlock operation, (2) proper door closing, (3) seal and sealing surfaces (arcing, wear, and other damage), (4) damage to or loosening of hinges and latches, (5) evidence of dropping or abuse.
- (c) Before turning on microwave power for any service test or inspection within the microwave generating compartments, check the magnetron, wave guide or transmission line, and cavity for proper alignment, integrity, and connections.
- (d) Any defective or misadjusted components in the interlock, monitor, door seal, and microwave generation and transmission systems shall be repaired, replaced, or adjusted by procedures described in this manual before the oven is released to the owner.
- (e) A microwave leakage check to verify compliance with the Federal Performance Standard should be performed on each oven prior to releasing oven to the owner.

BEFORE SERVICING

Before servicing an operative unit, perform a microwave emission check as per the Microwave Measurement Procedure outlined in this service manual.

If microwave emissions level is in excess of the specified limit, contact SHARP ELECTRONICS CORPORATION immediately @1-800-237-4277.

If the unit operates with the door open, service person should 1) tell the user not to operate the oven and 2) contact SHARP ELECTRONICS CORPORATION and Food and Drug Administration's Center for Devices and Radiological Health immediately.

Service personnel should inform SHARP ELECTRONICS CORPORATION of any certified unit found with emissions in excess of $4\text{mW}/\text{cm}^2$. The owner of the unit should be instructed not to use the unit until the oven has been brought into compliance.

WARNING TO SERVICE PERSONNEL

Microwave ovens contain circuitry capable of producing very high voltage and current, contact with following parts may result in a severe, possibly fatal, electrical shock.

(Example)

High Voltage Capacitor, High Voltage Power Transformer, Magnetron, High Voltage Rectifier Assembly, High Voltage Harness etc..

Read the Service Manual carefully and follow all instructions.

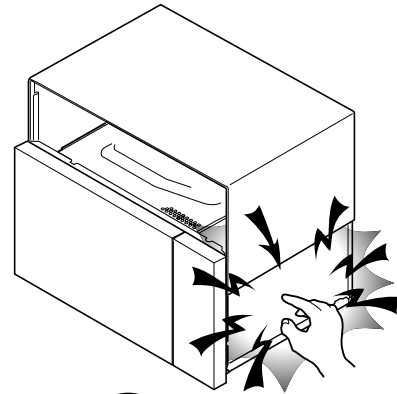

**Don't Touch !
Danger High Voltage**

Before Servicing

1. Disconnect the power supply cord,  and then remove outer case.
2. Open the door and block it open.
3. Discharge high voltage capacitor.

**WARNING: RISK OF ELECTRIC SHOCK.
DISCHARGE THE HIGH-VOLTAGE
CAPACITOR BEFORE SERVICING.**

The high-voltage capacitor remains charged about 60 seconds after the oven has been switched off. Wait for 60 seconds and then short-circuit the connection of the high-voltage capacitor (that is the connecting lead of the high-voltage rectifier) against the chassis with the use of an insulated screwdriver.

Whenever troubleshooting is performed the power supply must be disconnected. It may in, some cases, be necessary to connect the power supply after the outer case has been removed, in this event,

1. Disconnect the power supply cord, and then remove outer case.
2. Open the door and block it open.
3. Discharge high voltage capacitor.
4. Disconnect the leads to the primary of the power transformer.
5. Ensure that the leads remain isolated from other components and oven chassis by using insulation tape.
6. After that procedure, reconnect the power supply cord.

When the testing is completed,

1. Disconnect the power supply cord, and then remove outer case.
2. Open the door and block it open.
3. Discharge high voltage capacitor.
4. Reconnect the leads to the primary of the power transformer.
5. Reinstall the outer case (cabinet).
6. Reconnect the power supply cord after the outer case is installed.
7. Run the oven and check all functions.

After repairing

1. Reconnect all leads removed from components during testing.
2. Reinstall the outer case (cabinet).
3. Reconnect the power supply cord after the outer case is installed.
4. Run the oven and check all functions.

Microwave ovens should not be run empty. To test for the presence of microwave energy within a cavity, place a cup of cold water on the oven turntable, close the door and set the power to HIGH and set the microwave timer for two (2) minutes. When the two minutes has elapsed (timer at zero) carefully check that the water is now hot. If the water remains cold carry out **Before Servicing** procedure and re-examine the connections to the component being tested.

When all service work is completed and the oven is fully assembled, the microwave power output should be checked and microwave leakage test should be carried out.

MICROWAVE MEASUREMENT PROCEDURE

A. Requirements:

- 1) Microwave leakage limit (Power density limit): The power density of microwave radiation emitted by a microwave oven should not exceed $1\text{mW}/\text{cm}^2$ at any point 5cm or more from the external surface of the oven, measured prior to acquisition by a purchaser, and thereafter (through the useful life of the oven), $5\text{mW}/\text{cm}^2$ at any point 5cm or more from the external surface of the oven.
- 2) Safety interlock switches: Primary interlock relay and door sensing switch shall prevent microwave radiation emission in excess of the requirement as above mentioned, secondary interlock switch shall prevent microwave radiation emission in excess of $5\text{mW}/\text{cm}^2$ at any point 5cm or more from the external surface of the oven.

B. Preparation for testing:

Before beginning the actual measurement of leakage, proceed as follows:

- 1) Make sure that the actual instrument is operating normally as specified in its instruction booklet.

Important:

Survey instruments that comply with the requirement for instrumentation as prescribed by the performance standard for microwave ovens, 21 CFR 1030.10(c)(3)(i), must be used for testing.

- 2) Place the oven tray in the oven cavity.
- 3) Place the load of 275 ± 15 ml (9.8 oz) of tap water initially at $20\pm 5^\circ\text{C}$ (68°F) in the center of the oven cavity. The water container shall be a low form of 600 ml (20 oz) beaker with an inside diameter of approx. 8.5 cm (3-1/2 in.) and made of an electrically nonconductive material such as glass or plastic. The placing of this standard load in the oven is important not only to protect the oven, but also to insure that any leakage is measured accurately.
- 4) Set the cooking control on Full Power Cooking Mode
- 5) Close the door and select a cook cycle of several minutes. If the water begins to boil before the survey is completed, replace it with 275 ml of cool water.

C. Leakage test:

Closed-door leakage test (microwave measurement)

- 1) Grasp the probe of the survey instrument and hold it perpendicular to the gap between the door and the body of the oven.
- 2) Move the probe slowly, not faster than 1 in./sec. (2.5 cm/sec.) along the gap, watching for the maximum indication on the meter.
- 3) Check for leakage at the door screen, sheet metal seams and other accessible positions where the continuity of the metal has been breached (eg., around the switches, indicator, and vents). While testing for leakage around the door pull the door away from the front of the oven as far as is permitted by the closed latch assembly.
- 4) Measure carefully at the point of highest leakage and make sure that the highest leakage is no greater than $4\text{mW}/\text{cm}^2$, and that the primary interlock relay and secondary interlock switch do turn the oven OFF before any door movement.

NOTE: After servicing, record data on service invoice and microwave leakage report.

SERVICE MANUAL

SHARP

DOUBLE GRILL
CONVECTION
MICROWAVE OVEN

R-820JS

FOREWORD

This Manual has been prepared to provide Sharp Electronics Corp. Service Personnel with Operation and Service Information for the SHARP MICROWAVE OVEN, R-820JS.

It is recommended that service personnel carefully study the entire text of this manual so that they will be qualified to render satisfactory customer service.

Check the interlock switches and the door seal carefully. Special attention should be given to avoid electrical shock and microwave radiation hazard.

WARNING

Never operate the oven until the following points are ensured.

- (A) The door is tightly closed.
- (B) The door brackets and hinges are not defective.
- (C) The door packing is not damaged.
- (D) The door is not deformed or warped.
- (E) There is no other visible damage with the oven.

Servicing and repair work must be carried out only by trained service personnel.

DANGER

Certain initial parts are intentionally not grounded and present a risk of electrical shock only during servicing. Service personnel - Do not contact the following parts while the appliance is energized;

**High Voltage Capacitor, Power Transformer, Magnetron, High Voltage Rectifier Assembly, High Voltage Harness;
If provided, Vent Hood, Fan assembly, Cooling Fan Motor.**

All the parts marked "*" on parts list are used at voltages more than 250V.

Removal of the outer wrap gives access to voltage above 250V.

All the parts marked "Δ" on parts list may cause undue microwave exposure, by themselves, or when they are damaged, loosened or removed.

PRODUCT DESCRIPTION

GENERAL INFORMATION

OPERATION

TROUBLESHOOTING GUIDE AND
TEST PROCEDURE

TOUCH CONTROL PANEL

COMPONENT REPLACEMENT
AND ADJUSTMENT PROCEDURE

WIRING DIAGRAM

PARTS LIST

SHARP ELECTRONICS CORPORATION

SHARP PLAZA, MAHWAH,
NEW JERSEY 07430-2135

SPECIFICATION

ITEM	DESCRIPTION
Power Requirements	120 Volts 12.5 Amperes (Microwave) / 13.0 Amperes (Grill/ Convection) 60 Hertz / Single phase, 3 wire grounded
Power Output	900 watts (IEC Test Procedure) Operating frequency of 2450MHz
Top Heater Power Output	1000 Watts
Top & Bottom Heater Power Output	1500 Watts
Case Dimensions	Width 20-1/2" Height 12-1/8" Depth 19-3/4"
Cooking Cavity Dimensions (0.9 Cubic Feet)	Width 13-7/8" NOTE: Internal capacity is calculated by measuring maximum width, depth and height. Actual capacity for holding food is less. Height 7-1/2" Depth 14-1/2"
Control Complement	Touch Control System Timer (0 - 99 min. 99 seconds) Microwave Power for Variable Cooking Repetition Rate; HIGH POWER Full power throughout the cooking time 90 PERCENT approx. 90% of Full Power 80 PERCENT approx. 80% of Full Power 70 PERCENT approx. 70% of Full Power 60 PERCENT approx. 60% of Full Power 50 PERCENT approx. 50% of Full Power 40 PERCENT approx. 40% of Full Power 30 PERCENT approx. 30% of Full Power 20 PERCENT approx. 20% of Full Power 10 PERCENT approx. 10% of Full Power 0 PERCENT No power throughout the cooking time Grill Cooking (GRILL) Top and Bottom Grill Mode / Top Grill Mode only Convection Cooking (CONVEC) 100 - 450°F Temp. control Roast Cooking (ROAST) 325°F with 30% microwave power CUSTOM HELP pad, AUTO COOK/ BAKE/ PIZZA/ GRILL/ ROAST pads AUTO DEFROST pad, CONVEC pad, GRILL pad, ROAST pad POPCORN pad, REHEAT pad, MINUTE PLUS pad Number and temperature selection pads, KITCHEN TIMER pad, CLOCK pad STOP/CLEAR pad, POWER LEVEL pad, START / TOUCH ON pad
Oven Cavity Light	Yes
Safety Standard	UL Listed FCC Authorized DHHS Rules, CFR, Title 21, Chapter 1, Subchapter J

GENERAL INFORMATION

GROUNDING INSTRUCTIONS

This oven is equipped with a three prong grounding plug. It must be plugged into a wall receptacle that is properly installed and grounded in accordance with the National Electrical Code and local codes and ordinances.

In the event of an electrical short circuit, grounding reduces the risk of electric shock by providing an escape wire for the electric current.

WARNING: Improper use of the grounding plug can result in a risk of electric shock.

Electrical Requirements

The electrical requirements are a 115 -120 volt 60 Hz, AC only, 15 or 20 amp. fused electrical supply. It is recommended that a separate circuit serving only this appliance be provided. When installing this appliance, observe all applicable codes and ordinances.

A short power-supply cord is provided to reduce risks of becoming entangled in or tripping over a longer cord.

Where a two-pronged wall-receptacle is encountered, it is the personal responsibility and obligation of the customer to contact a qualified electrician and have it replaced with a properly grounded three-pronged wall receptacle or have a grounding adapter properly grounded and polarized. If the extension cord must be used, it should be a 3-wire, 15 amp. or higher rated cord. Do not drape over a countertop or table where it can be pulled on by children or tripped over accidentally.

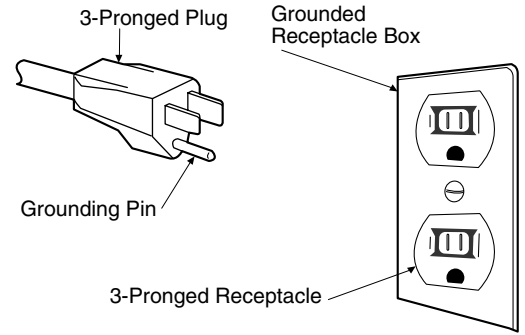

CAUTION: DO NOT UNDER ANY CIRCUMSTANCES CUT OR REMOVE THE ROUND GROUNDING PRONG FROM THIS PLUG.

OVEN DIAGRAM

1. Oven light
2. Top heaters (Grill heaters)
3. Oven door with see through window
4. Door hinges
5. Safety door latches
6. Door seals and sealing surfaces
7. Bottom heater
8. Oven cavity
9. Turntable motor shaft
10. Ventilation openings
11. Waveguide cover
12. One touch door opening button
13. Auto-Touch control panel
14. Time display
15. Power supply cord
16. Outer cabinet
17. Menu label

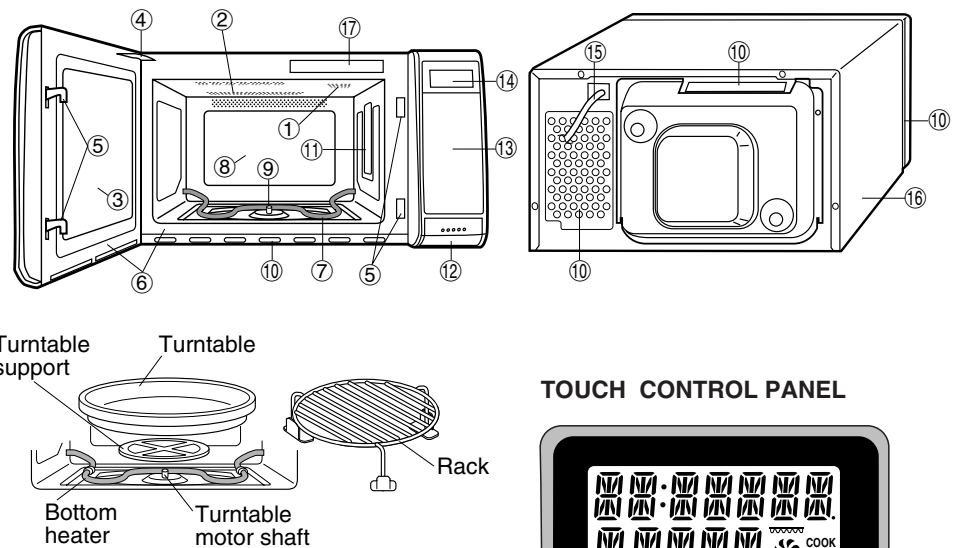

NOTE:

1. Ensure that the bottom heater is in the lowest position as shown in the figure, as it is possible to move it up and down to help with cleaning.
2. Place the turntable support over the turntable motor shaft on the floor of the cavity.
3. Then place the turntable onto the turntable support.

TOUCH CONTROL PANEL



OPERATION

DESCRIPTION OF OPERATING SEQUENCE

The following is a description of component functions during oven operation.

OFF CONDITION

Closing the door activates door sensing switch and secondary interlock switch. (In this condition, the monitor switch contacts are opened.)

When oven is plugged in, 120 volts A.C. is supplied to the control unit. (Figure O-1).

1. The display will show , , , , , , , and .

To set any program or set the clock, you must first touch the STOP/CLEAR pad. The display will clear, and " : " will appear.

MICROWAVE COOKING CONDITION

Program desired cooking time by touching the NUMBER pads. Program the power level by touching the POWER LEVEL pad and then a Number pad. When the START pad is touched, the following operations occur:

1. The contacts of relays are closed and components connected to the relays are turned on as follows. (For details, refer to Figure O-2)

RELAY	CONNECTED COMPONENTS
RY-2	Power transformer
RY-5	Fan motor
RY-6	Oven lamp/ Turntable motor

2. 120 volts A.C. is supplied to the primary winding of the power transformer and is converted to about 3.1 volts A.C. output on the filament winding, and approximately 2260 volts A.C. on the high voltage winding.
3. The filament winding voltage heats the magnetron filament and the H.V. winding voltage is sent to a voltage doubler circuit.
4. The microwave energy produced by the magnetron is channelled through the waveguide into the cavity feed-box, and then into the cavity where the food is placed to be cooked.
5. Upon completion of the cooking time, the power transformer, oven lamp, etc. are turned off, and the generation of microwave energy is stopped. The oven will revert to the OFF condition.
6. When the door is opened during a cook cycle, monitor switch, door sensing switch, secondary interlock switch, relay (RY5), relay (RY6) and primary interlock relay(RY2) are activated with the following results. The circuits to the turntable motor, the cooling fan motor, and the high voltage components are de-energized, the oven lamp remains on, and the digital read-out displays the time still remaining in the cook cycle when the door was opened.
7. The monitor switch electrically monitors the operation of

the secondary interlock switch and primary interlock relay and is mechanically associated with the door so that it will function in the following sequence.

- (1) When the door opens from the closed position, the relay (RY5), primary interlock relay(RY2) and secondary interlock switch open their contacts. And contacts of the relay(RY6) remains closed. Then the monitor switch contacts close.
- (2) When the door is closed from the open position, the monitor switch contacts open first. Then the contacts of the secondary interlock switch and door sensing switch close. And contacts of the relay(RY6) open.

If the secondary interlock switch and primary interlock relay (RY2) fail with the contacts closed when the door is opened, the closing of the monitor switch contacts will form a short circuit through the monitor fuse, secondary interlock switch, relay(RY6) and primary interlock relay(RY2), causing the monitor fuse to blow.

POWER LEVEL P-0 TO P-90 COOKING

When Variable Cooking Power is programmed, the 120 volts A.C. is supplied to the power transformer intermittently through the contacts of relay(RY-2) which is operated by the control unit within a 32 second time base. Microwave power operation is as follows:

VARI-MODE	ON TIME	OFF TIME
HIGH POWER	32 sec.	0 sec.
90 PERCENT	30 sec.	2 sec.
80 PERCENT	26 sec.	6 sec.
70 PERCENT	24 sec.	8 sec.
60 PERCENT	22 sec.	10 sec.
50 PERCENT	18 sec.	14 sec.
40 PERCENT	16 sec.	16 sec.
30 PERCENT	12 sec.	20 sec.
20 PERCENT	8 sec.	24 sec.
10 PERCENT	6 sec.	26 sec.
0 PERCENT	0 sec.	32 sec.

Note: The ON/OFF time ratio does not correspond with the percentage of microwave power, because approx. 3 seconds are needed for heating of the magnetron filament.

GRILL COOKING CONDITIONS

The oven has two grill cooking conditions. They are the TOP HEATER mode and TOP AND BOTTOM HEATER mode.

TOP AND BOTTOM HEATER MODE

In this mode, the food is cooked by both the top heaters and bottom heater. Press the GRILL pad and number "1" pad and then enter the cooking time by pressing the number pads. When the START pad is pressed, the following operations occur (Figure O-3a):

1. The relays(RY3, RY4, RY5 and RY6) are energized.

2. The numbers of the digital read-out start the count down to zero.
3. Then the top heaters, bottom heater, turntable motor, oven lamp and fan motor are energized.
4. Now, the food is grilled by the top heaters and the bottom heater.
5. Upon completion of the selected cooking time, audible signal sounds and the contacts of relays(RY3, RY4 and RY6) are opened, then the top heating elements, bottom heating element, turntable motor and oven lamp are de-energized. But the relay(RY5) stays closed and the fan motor operates for 5 minutes. But if the cooking time is less than 2 minutes the relay(RY5) will not stay closed.

NOTE: If the total grill cooking time is beyond 35 minutes, the relay(RY1) is energized and the convection motor is energized.

TOP HEATER MODE

In this mode, the food is cooked by the top heaters. Press the GRILL pad and number "2" pad and then enter the cooking time by pressing the number pads. When the START pad is pressed, the following operations occur (Figure O-3b):

1. The relays(RY3, RY5 and RY6) are energized.
2. The numbers of the digital read-out start the count down to zero.
3. Then the top heaters, turntable motor, oven lamp and fan motor are energized.
4. Now, the food is grilled by the top heaters.
5. Upon completion of the selected cooking time, audible signal sounds and the contacts of relays(RY3 and RY6) are opened, then the top heaters, turntable motor and oven lamp are de-energized. But the relay(RY5) stays closed and the fan motor operates for 5 minutes. But if the cooking time is less than 2 minutes the relay(RY5) will not stay close.

NOTE: If the total grill cooking time is beyond 35 minutes, the relay(RY1) is energized and the convection motor is energized.

CONVECTION COOKING CONDITION WITH PREHEAT

Touch the CONVEC pad and select the convection with preheat mode by touching the number "1" pad.

1. Program desired convection temperature by touching the Temperature pad. Enter the cooking time by touching the number pads. When the START pad is touched, the following operations occur:

PREHEATING CONDITION

2. The coil of shut-off relays (RY5 and RY6) are energized, the oven lamp, cooling fan motor and turntable motor are turned on.
3. The coil of relays(RY3 and RY4) are energized by the control unit, and the top heaters and the bottom heater work with 100% power. The relay(RY1) and the convection motor are not energized at this preheating condition.

NOTE: If the cavity temperature is lower than 100°F(38C) at 4 minutes and 15 seconds after the preheat is started, the control unit judges that the thermistor is opened. And the oven is stopped.

4. When the oven temperature reaches the selected preheat temperature, the following operations occur:
 - 4-1 The relays(RY3 and RY4) are de-energized by the control unit temperature circuit and thermistor, opening the circuit to the heating element.
 - 4-2. The oven will continue to function for 30 minutes, turning the top heaters and the bottom heater on and off, as needed to maintain the selected preheat temperature. The oven will shutdown completely after 30 minutes

CONVECTION TIME COOKING CONDITION

5. When the preheat temperature is reached, a beep signal will sound indicating that the holding temperature has been reached in the oven cavity. Open the door and place the food to be cooked in the oven. When the START pad is touched, the following operations occur:
6. The numbers on the digital read-out start to count down to zero.
7. The relays(RY1, RY5 and RY6) are energized and the oven lamp, turntable motor, cooling fan motor and convection motor are energized.
8. The relays(RY3 and RY4) are energized (if the cavity temperature is lower than the selected temperature) and the main supply voltage is applied to the heating element to return to the selected cooking temperature. The top heaters and the bottom heater work in accordance with the following table while the heaters are energized.

Selected Temperature (°F)	Top Heaters Power (%)	Bottom Heaters Power (%)
100	20	10(after 3min. 0%)
150	20	10
275	40	40
300	40	50
325	50	50
350	50	60
375	60	60
400	60	70
425	70	70
450	70	80

9. Upon completion of the cooking time, the audible signal will sound, and oven lamp, turntable motor, cooling fan motor and convection motor are de-energized. At the end of the convection cycle, if the cavity air temperature is above 250°F(120°C), the circuit to RY5 will be maintained (by the thermistor circuit) to continue operation of the cooling fan motor until the temperature drops below 220°F(104°C), at which time the relay will be de-energized, turning off the fan motor. Relay RY1 will however, open as soon as the convection cycle has ended, turning off the convection fan motor.

ROAST COOKING CONDITION

Touch the ROAST pad once. And then program desired cooking time by touching the number pads. The ROAST pad is preprogrammed for 325°F with 30% microwave power.

NOTE: The microwave power can not be changed. To change the temperature, touch the ROAST pad twice. When the display says "SELECT TEMP", touch desired temperature pad.

When the START pad is pressed, the following operations occur:

1. The numbers on the digital read-out start to count down.
2. The shut-off relays(RY1, RY5 and RY6) are energized, turning on the oven lamp, turntable motor, cooling fan motor and convection motor.
3. The microwave relay(RY2) is energized for 16 seconds within a 48 second time base.
4. The heater relays(RY3 and RY4) are energized intermittently within a 48 second time base. The power output is set in accordance with the following table.

Selected Temperature (°F)	Top Heaters Power (%)	Bottom Heaters Power (%)
100	20	40
150	30	50
275	50	60
300	60	70
325	70	70
350	70	70
375	70	70
400	70	70
425	70	70
450	70	70

5. The microwave relay(RY2) and the heater relays(RY3 and RY4) are not energized simultaneously.

ON/OFF TIME RATIO

In grill cooking, convection cooking or roast cooking, the top heaters, bottom heater or magnetron operate within a 48 second time base. The following table is the ON / OFF time ratio at each power output of the top heaters, bottom heater or magnetron.

POWER OUTPUT	ON TIME	OFF TIME
100%	48 sec.	0 sec.
90%	44 sec.	4 sec.
80%	40 sec.	8 sec.
70%	36 sec.	12 sec.
60%	32 sec.	16 sec.
50%	26 sec.	22 sec.
40%	22 sec.	26 sec.
30%	16 sec.	32 sec.
20%	12 sec.	36 sec.
10%	8 sec.	40 sec.

FIRE SENSING FEATURE (MICROWAVE MODE)

This model incorporates a sensing feature which will stop the oven's operation if there is a fire in the oven cavity during microwave cooking.

This is accomplished by the LSI repeatedly measuring the

voltage across the temperature measurement circuit (thermistor) during its 32-seconds time base comparing the obtained voltage measurements. If the most recent voltage measured is 700mV greater than the previous voltage measured, the LSI judges it as a fire in the oven cavity and switches off the relays to the power transformer, fan motor, oven lamp and turntable motor. The LSI also stops counting down. Please refer to the following section for a more detailed description.

Operation

Please refer to the timing diagrams below.

1. The thermistor operates within a 32-seconds time base and it is energized for three (3) seconds and off for 29 seconds. Two (2) seconds after the thermistor is energized, the voltage across the temperature measurement circuit is sampled by the LSI and twenty one (21) seconds after the thermistor is cut off the LSI turns on the cooling fan for six (6) seconds.
2. The above procedure is repeated. If the difference between the first voltage measured (in step 1) and the voltage measured when the procedure is repeated (step 2) is greater than 700mV the LSI makes the judgment that there is a fire in the oven cavity and will switch off the relays to the power transformer, fan motor, oven lamp and turntable motor. The LSI also stops counting down.
3. Once the fire sensor feature has shut the unit down, the programmed cooking cycle may be resumed by pressing the "START" pad or the unit may be reset by pressing the "CLEAR" pad.

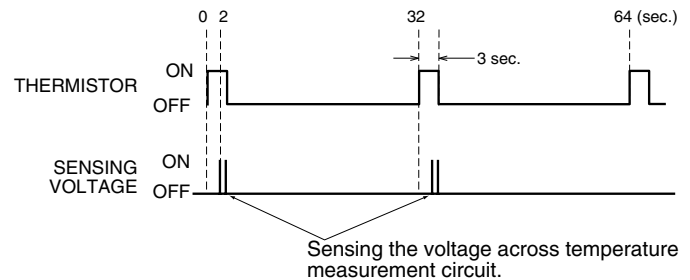

SCHMATIC
 NOTE: CONDITION OF OVEN
 1. DOOR CLOSED.
 2. : OR CLOCK APPEAR ON DISPLAY.

NOTE: ★ Indicates components with potential above 250 V.

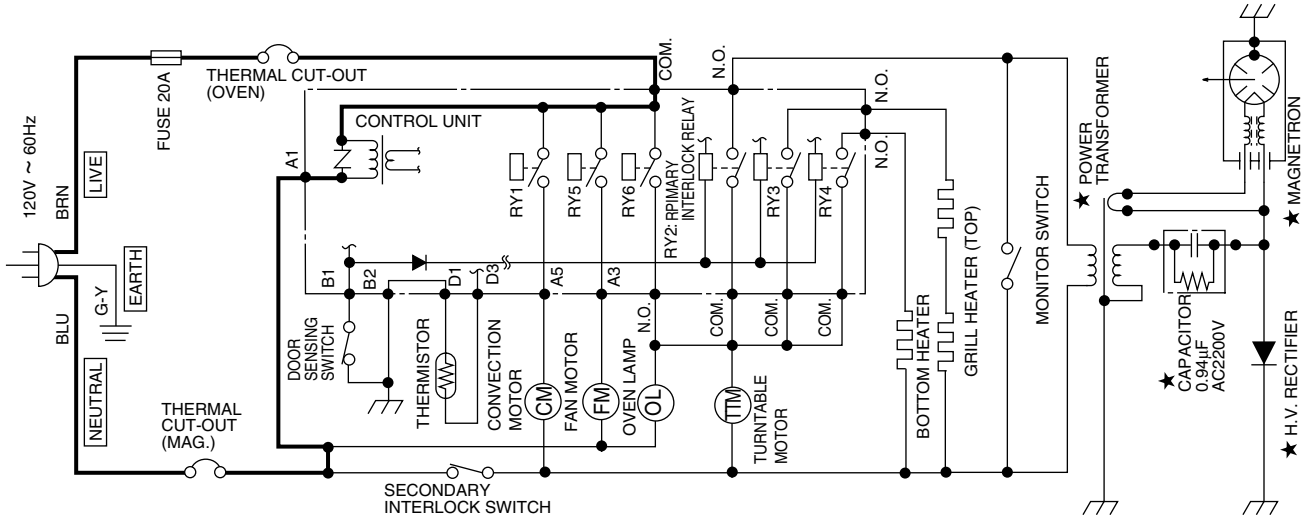

Figure O-1 Oven Schematic-Off Condition

SCHMATIC
 NOTE: CONDITION OF OVEN
 1. DOOR CLOSED.
 2. MICROWAVE POWER LEVEL PAD PRESSED ONCE(100%).
 3. COOKING TIME PROGRAMMED.
 4. START PAD TOUCHED.

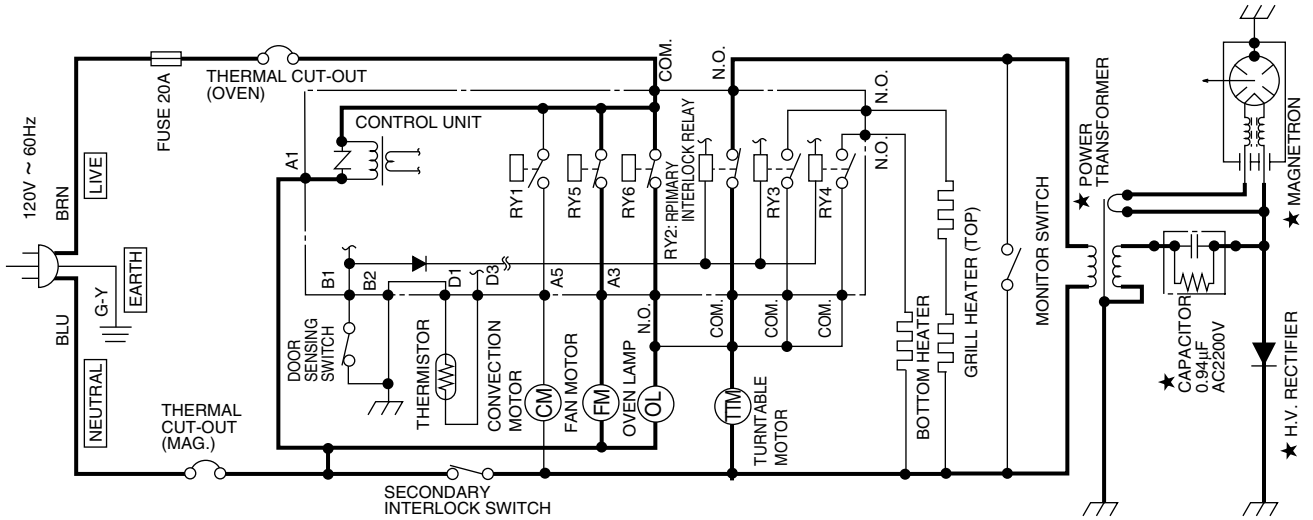

Figure O-2 Oven Schematic-Microwave cooking Condition

SCHMATIC
NOTE: CONDITION OF OVEN
1. DOOR CLOSED.
2. GRILL PAD TOUCHED.
3. NUMBER "1" PAD TOUCHED.
4. COOKING TIME PROGRAMMED.
5. START PAD TOUCHED.

NOTE: ★ Indicates components with potential above 250 V.

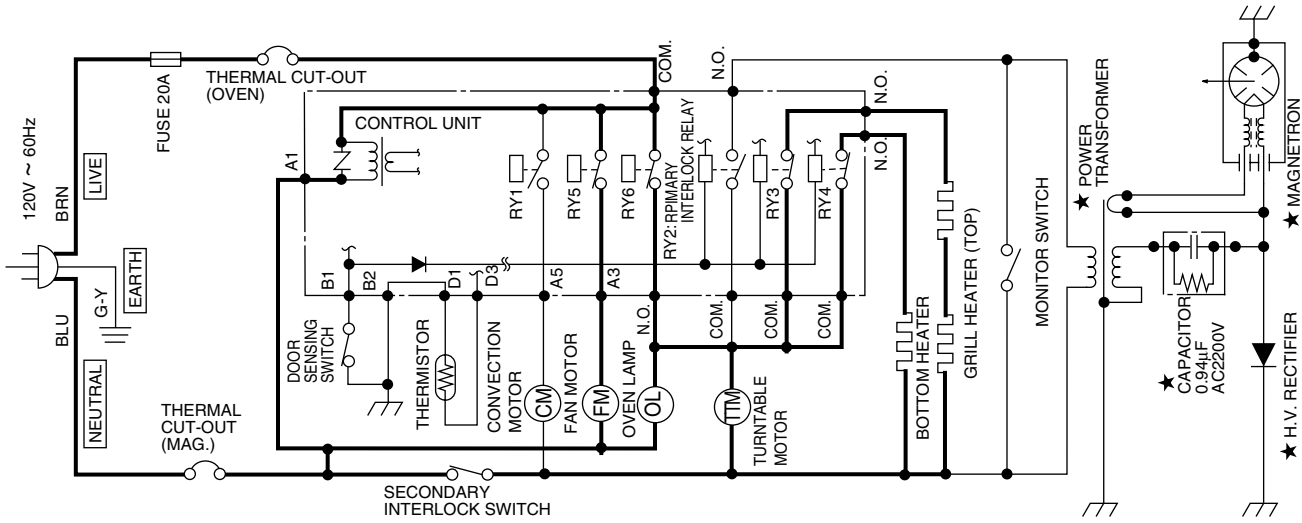

Figure O-3a Oven Schematic-Grill cooking Condition (TOP AND BOTTOM HEATER mode)

SCHMATIC
NOTE: CONDITION OF OVEN
1. DOOR CLOSED.
2. GRILL PAD TOUCHED.
3. NUMBER "2" PAD TOUCHED.
4. COOKING TIME PROGRAMMED.
5. START PAD TOUCHED.

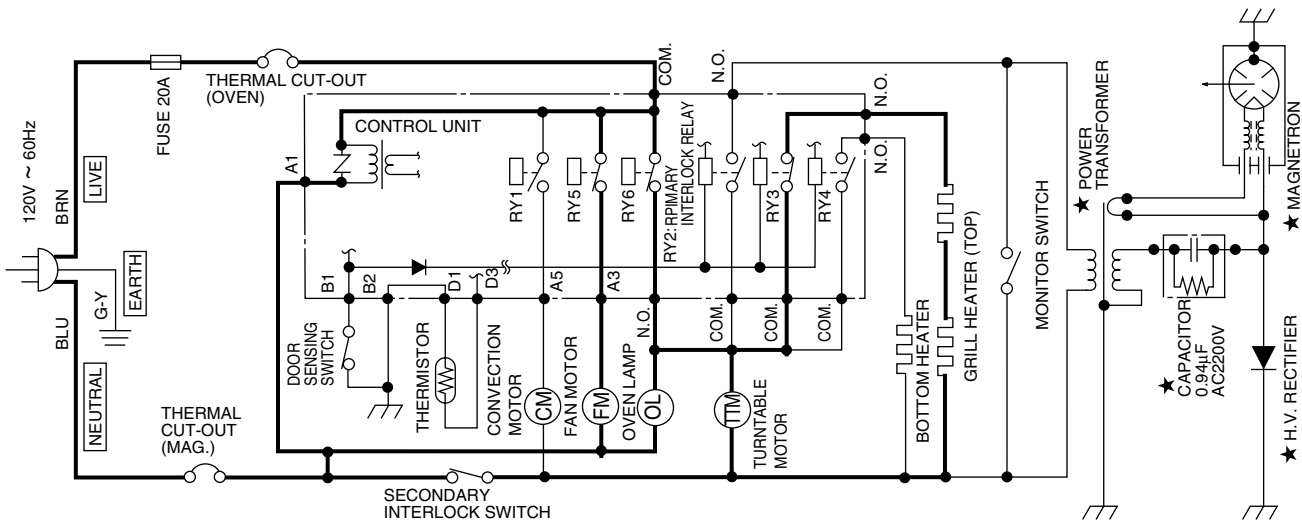

Figure O-3b Oven Schematic-Grill cooking Condition (TOP HEATER mode)

SCHMATIC
NOTE: CONDITION OF OVEN
1. DOOR CLOSED.
2. CONVECTION PAD TOUCHED.
3. NUMBER "1" PAD TOUCHED.
4. TEMPERATURE PAD TOUCHED.
5. COOKING TIME PROGRAMMED.
6. START PAD TOUCHED.

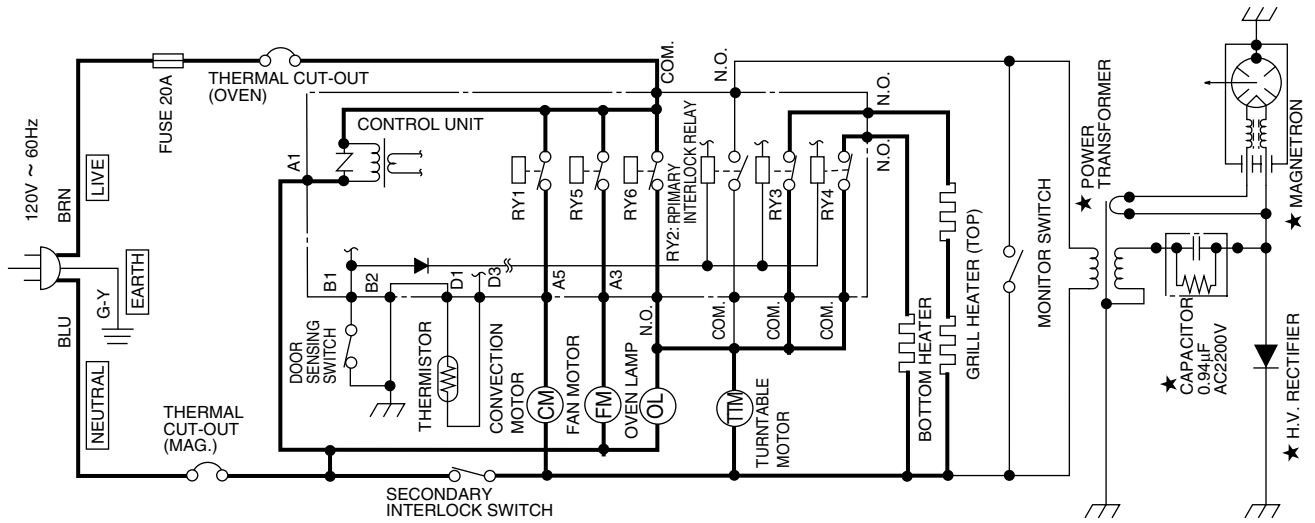

Figure O-4 Oven Schematic-Convection cooking Condition (Convection with preheat mode)

SCHMATIC
NOTE: CONDITION OF OVEN
1. DOOR CLOSED.
2. ROAST PAD TOUCHED.
3. COOKING TIME PROGRAMMED.
4. START PAD TOUCHED.

NOTE: The microwave relay (RY2) and the heater relay (RY3 or RY4) are not energized simultaneously.

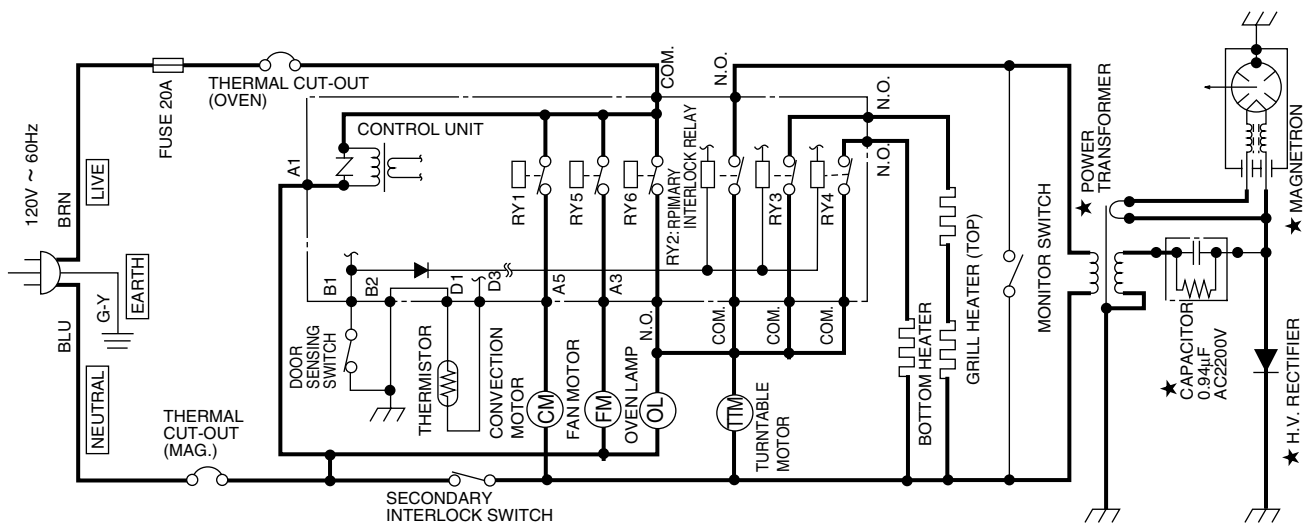

Figure O-5 Oven Schematic-Roast cooking Condition

DESCRIPTION AND FUNCTION OF COMPONENTS

DOOR OPEN MECHANISM

The door is opened by pushing the open button on the control panel, refer to Figure D-1.

When the open button is pushed, the open button pushes up the switch lever, and then the switch lever pushes up the latch head. The latch heads are moved upward and released from latch hook. Now the door will open.

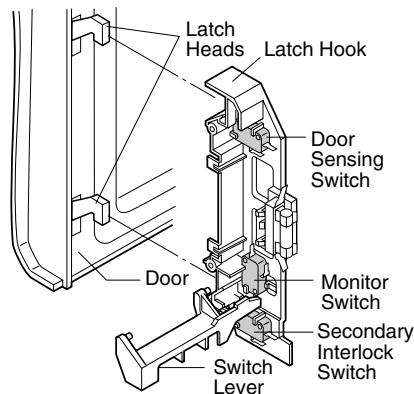

Figure D-1. Door Open Mechanism

DOOR SENSING AND SECONDARY INTERLOCK SWITCHES

The secondary interlock switch is mounted in the lower position of the latch hook and the door sensing switch in the primary interlock system is mounted in the upper position of the latch hook. They are activated by the latch heads on the door. When the door is opened, the switches interrupt the power to all high voltage components. A cook cycle cannot take place until the door is firmly closed thereby activating both interlock switches. The primary interlock system consists of the door sensing switch and primary interlock relay located on the control circuit board.

MONITOR SWITCH

The monitor switch is activated (the contacts opened) by the latch head on the door while the door is closed. The switch is intended to render the oven inoperative, by means of blowing the monitor fuse, when the contacts of the primary interlock relay (RY2) and secondary interlock switch fail to open when the door is opened.

Functions:

1. When the door is opened, the monitor switch contacts close (to the ON condition) due to their being normally closed. At this time the primary interlock relay (RY2) and secondary interlock switch are in the OFF condition (contacts open) due to their being normally open contact switches.
2. As the door goes to a closed position, the monitor switch contacts are first opened and then the door sensing switch and the secondary interlock switch contacts close. (On opening the door, each of these switches operate inversely.)
3. If the door is opened, and the primary interlock relay (RY2) and secondary interlock switch contacts fail to open, the monitor fuse blows simultaneously with closing

of the monitor switch contacts.

CAUTION: BEFORE REPLACING A BLOWN MONITOR FUSE TEST THE DOOR SENSING SWITCH, PRIMARY INTERLOCK RELAY (RY2), RELAY (RY6), SECONDARY INTERLOCK SWITCH AND MONITOR SWITCH FOR PROPER OPERATION. (REFER TO CHAPTER "TEST PROCEDURE").

NOTE: MONITOR FUSE AND MONITOR SWITCH ARE REPLACED AS AN ASSEMBLY.

TURNTABLE MOTOR

The turntable motor rotates the turntable located on the bottom of the oven cavity, so that the food on the turntable cook evenly during cooking. The turntable may turn in either direction.

COOLING FAN MOTOR

The cooling fan motor drives a blade which draws external cool air. This cool air is directed through the air vanes surrounding the magnetron and cools the magnetron. This air is channelled through the oven cavity to remove steam and vapors given off from the heating food. It is then exhausted through the exhausting air vents at the oven cavity.

MONITOR FUSE

1. The monitor fuse blows when the contacts (COM-NO) of the primary interlock relay (RY2) and secondary interlock switch remain closed with the oven door open and when the monitor switch closes.
2. If the wire harness or electrical components are short-circuited, this monitor fuse blows to prevent an electric shock or fire hazard.

THERMAL CUT-OUT 125°C (MAGNETRON)

This thermal cut-out protects the magnetron against overheating. If the temperature goes up higher than 257°F (125°C) because the fan motor is interrupted or the ventilation openings are blocked, the thermal cut-out will open and line voltages to the high voltage transformer will be cut off and the operation of the magnetron will be stopped. The thermal cut-out will not resume.

THERMAL CUT-OUT 170°C (OVEN)

The thermal cut-out located on the top of the oven cavity is designed to prevent damage to the oven if the food in the oven catch fire due to over heating produced by improper setting of the cooking time or failure of control unit. Under the normal operation, the oven thermal cut-out remains closed. However, when abnormally high temperatures are reached within the oven cavity, the oven thermal cut-out will open at 338°F(170°C) causing the oven to shut down. The thermal cut-out will close in at 311°F(155°C).

TOP HEATERS

The top heaters are located on the top of the oven cavity assembly. The top heaters send out heat to grill foods.

BOTTOM HEATER

The bottom heater is located on the floor of the oven cavity assembly. The bottom heater sends out heat to grill foods.

CONVECTION COOKING SYSTEM

This oven is designed with a hot air heating system where food is not directly heated by the top heaters and the bottom heater, but is heated by forced circulation of the hot air produced by the top heaters and the bottom heater.

The air heated by the top heaters and the bottom heater is circulated through the convection passage provided on the outer casing of the oven cavity by means of the convection fan which is driven by the convection motor. It then enters the inside of the oven through the vent holes provided on the left side of the oven. Next, the hot air heats the food on the turntable and leaves the oven cavity through the vent in the center of the oven cavity rear wall.

Most of this hot air is reheated by the top heaters and the bottom heater and passes through the convection passage and enters the inside of the oven cavity again, in a continuing cycle.

In this way, the hot air circulates inside the oven cavity to raise its temperature and, at the same time, comes into contact with the food being cooked.

When the temperature inside the oven cavity reaches the selected temperature, the top heaters and the bottom heater are de-energized. When the temperature inside the oven cavity drops below the selected temperature, the top heaters and the bottom heater are energized again. In this way, the inside of the oven cavity is maintained at approximately the selected temperature.

When the convection time reaches 0, the top heaters and the bottom heater are de-energized and the convection fan stops operating and the oven shuts off.

TROUBLESHOOTING GUIDE

Never touch any part in the circuit with your hand or an uninsulated tool while the power supply is connected.

When troubleshooting the microwave oven, it is helpful to follow the Sequence of Operation in performing the checks. Many of the possible causes of trouble will require that a specific test be performed. These tests are given a procedure letter which will be found in the "Test Procedure "section.

IMPORTANT: If the oven becomes inoperative because of a blown monitor fuse, check the monitor switch, relay (RY6), primary interlock relay (RY2), door sensing switch and secondary interlock switch before replacing the monitor fuse. If monitor fuse is replaced, the monitor switch must also be replaced. Use part FFS-BA021WRK0 as an assembly.

IMPORTANT: Whenever troubleshooting is performed with the power supply cord disconnected. It may in, some cases, be necessary to connect the power supply cord after the outer case has been removed, in this event,

1. Disconnect the power supply cord, and then remove outer case.
2. Open the door and block it open.
3. Discharge high voltage capacitor.
4. Disconnect the leads to the primary of the power transformer.
5. Ensure that the leads remain isolated from other components and oven chassis by using insulation tape.
6. After that procedure, reconnect the power supply cord.

When the testing is completed

1. Disconnect the power supply cord, and then remove outer case.
2. Open the door and block it open.
3. Discharge high voltage capacitor.
4. Reconnect the leads to the primary of the power transformer.
5. Reinstall the outer case (cabinet).
6. Reconnect the power supply cord after the outer case is installed.
7. Run the oven and check all functions.

TEST PROCEDURE		A	B	C	D	E	F	F	G	H	I	I	J	L	M	N	N	N	N	N	O	P	RE	RE	RE	RE	RE	RE	CK	CK	CK							
POSSIBLE CASE AND DEFECTIVE PARTS		MAGNETRON	POWER TRANSFORMER	H.V. RECTIFIER ASSEMBLY	HIGH VOLTAGE CAPACITOR	THERMAL CUT-OUT 170°C	THERMAL CUT-OUT 125°C	SECONDARY INTERLOCK SWITCH	PRIMARY INTERLOCK SYSTEM	MONITOR SWITCH	MONITOR FUSE	TOP HEATERS	BOTTOM HEATER	THERMISTOR	TOUCH CONTROL PANEL	KEY UNIT	RELAY RY1	RELAY RY2	RELAY RY3	RELAY RY4	RELAY RY5	RELAY RY6	AUTO DEFROST	FOIL PATTERN ON P.W.B.	CONVECTION MOTOR	FAN MOTOR	TURNTABLE MOTOR	POWER SUPPLY CORD	OVEN LAMP OR SOCKET	SHORTED WIRE HARNESS	OPENED WIRE HARNESS	MIS-ADJUSTMENT OF SWITCHES						
CONDITION	PROBLEM																																					
OFF CONDITION	Monitor fuse blows when power cord is plugged into wall outlet.																																					
	Monitor fuse blows when the door is opened.																																					
	Oven lamp does not light when door is opened. (Display operates.)																																					
	Home fuse blows when power cord is plugged into wall outlet.																																					
	"SHARP SIMPLY PRESS CLOCK" does not appear in display when power cord is plugged into wall outlet.																																					
	Display does not operate properly when STOP/CLEAR pad is pressed.																																					
COOKING CONDITION (COMMON MODE)	Oven does not start when the START pad is pressed. (Display operates.)																																					
	Oven lamp does not light. (Turntable motor operates.)																																					
	Fan motor does not operate. (Oven lamp lights.)																																					
	Turntable motor does not operate. (Oven lamp lights.)																																					
	Oven or electrical parts does not stop when cooking time is 0 or STOP/CLEAR pad is pressed.																																					
	Oven goes into cook cycle but shuts down before end of cooking cycle.																																					
MICROWAVE COOKING CONDITION	Oven seems to be operating but little or no heat is produced in oven load.																																					
	Oven does not operate properly during variable cooking condition except 100% cooking condition.																																					
	Function of AUTO DEFROST does not operate properly.																																					
GRILL COOKING CONDITION	Top heaters do not operate.																																					
	Bottom heater does not operate.																																					
ROAST COOKING CONDITION	Oven seems to be operating but little or no heat is produced in oven load. (Microwave power does not seem to be generated properly.)																																					
	Top heaters do not operate.																																					
	Bottom heater does not operate.																																					
CONVECTION COOKING CONDITION	Temperature is lower or higher than preset.																																					
	Convection motor does not operate.																																					
	Oven stops after 4 minutes 15 sec..																																					

TEST PROCEDURES

PROCEDURE LETTER	COMPONENT TEST
A	<p><u>MAGNETRON ASSEMBLY TEST</u></p> <ol style="list-style-type: none"> 1. Disconnect the power supply cord, and then remove outer case. 2. Open the door and block it open. 3. Discharge high voltage capacitor. 4. To test for an open filament, isolate the magnetron from the high voltage circuit. A continuity check across the magnetron filament leads should indicate less than 1 ohm. 5. To test for a shorted magnetron, connect the ohmmeter leads between the magnetron filament leads and chassis ground. This test should indicate an infinite resistance. If there is little or no resistance the magnetron is grounded and must be replaced. 6. Reconnect all leads removed from components during testing. 7. Reinstall the outer case (cabinet). 8. Reconnect the power supply cord after the outer case is installed. 9. Run the oven and check all functions. <p><u>MICROWAVE OUTPUT POWER</u></p> <p>The following test procedure should be carried out with the microwave oven in a fully assembled condition (outer case fitted).</p> <p>HIGH VOLTAGES ARE PRESENT DURING THE COOK CYCLE, SO EXTREME CAUTION SHOULD BE OBSERVED.</p> <p>Power output of the magnetron can be measured by performing a water temperature rise test. This test should only be used if above tests do not indicate a faulty magnetron and there is no defect in the following components or wiring: silicon rectifier, high voltage capacitor and power transformer. This test will require a 16 ounce (453cc) measuring cup and an accurate mercury thermometer or thermocouple type temperature tester. For accurate results, the following procedure must be followed carefully:</p> <ol style="list-style-type: none"> 1. Fill the measuring cup with 16 oz. (453cc) of tap water and measure the temperature of the water with a thermometer or thermocouple temperature tester. Stir the thermometer or thermocouple through the water until the temperature stabilizes. Record the temperature of the water. 2. Place the cup of water in the oven. Operate oven at POWER 10(HIGH) selecting more than 60 seconds cook time. Allow the water to heat for 60 seconds, measuring with a stop watch, second hand of a watch or the digital read-out countdown. 3. Remove the cup from the oven and again measure the temperature, making sure to stir the thermometer or thermocouple through the water until the maximum temperature is recorded. 4. Subtract the cold water temperature from the hot water temperature. The normal result should be 22 to 43°F(12.2 to 23.9°C) rise in temperature. If the water temperatures are accurately measured and tested for the required time period the test results will indicate if the magnetron tube has low power output (low rise in water temperature) which would extend cooking time or high power output (high rise in water temperature) which would reduce cooking time. Because cooking time can be adjusted to compensate for power output, the magnetron tube assembly should be replaced only if the water temperature rise test indicates a power output well beyond the normal limits. The test is only accurate if the power supply line voltage is 120 volts and the oven cavity is clean.
B	<p><u>POWER TRANSFORMER TEST</u></p> <ol style="list-style-type: none"> 1. Disconnect the power supply cord, and then remove outer case. 2. Open the door and block it open. 3. Discharge high voltage capacitor. 4. Disconnect the primary input terminals and measure the resistance of the transformer with an ohmmeter. Check for continuity of the coils with an ohmmeter. On the R x 1 scale, the resistance of the primary coil should be less than 1 ohm and the resistance of the high voltage coil should be approximately 73 ohms; the resistance of the filament coil should be less than 1 ohm. 5. Reconnect all leads removed from components during testing. 6. Reinstall the outer case (cabinet). 7. Reconnect the power supply cord after the outer case is installed. 8. Run the oven and check all functions.

TEST PROCEDURES

PROCEDURE LETTER	COMPONENT TEST
	(HIGH VOLTAGES ARE PRESENT AT THE HIGH VOLTAGE TERMINAL, SO DO NOT ATTEMPT TO MEASURE THE FILAMENT AND HIGH VOLTAGE.)
C	<p><u>HIGH VOLTAGE RECTIFIER TEST</u></p> <ol style="list-style-type: none"> 1. Disconnect the power supply cord, and then remove outer case. 2. Open the door and block it open. 3. Discharge high voltage capacitor. 4. Isolate the rectifier from the circuit. Using the highest ohm scale of the meter, read the resistance across the terminals and observe, reverse the leads to the rectifier terminals and observe meter reading. If a short is indicated in both directions, or if an infinite resistance is read in both directions, the rectifier is probably defective and should be replaced. 5. Reconnect all leads removed from components during testing. 6. Reinstall the outer case (cabinet). 7. Reconnect the power supply cord after the outer case is installed. 8. Run the oven and check all functions. <p>NOTE: Be sure to use an ohmmeter that will supply a forward bias voltage of more than 6.3 volts.</p>
D	<p><u>HIGH VOLTAGE CAPACITOR TEST</u></p> <ol style="list-style-type: none"> 1. Disconnect the power supply cord, and then remove outer case. 2. Open the door and block it open. 3. Discharge high voltage capacitor. 4. If the capacitor is open, no high voltage will be available to the magnetron. Disconnect input leads and check for a short or open between the terminals using an ohmmeter. Checking with a high ohm scale, if the high voltage capacitor is normal, the meter will indicate continuity for a short time and should indicate an open circuit once the capacitor is charged. If the above is not the case, check the capacitor with an ohmmeter to see if it is shorted between either of the terminals and case. If it is shorted, replace the capacitor. 5. Reconnect all leads removed from components during testing. 6. Reinstall the outer case (cabinet). 7. Reconnect the power supply cord after the outer case is installed. 8. Run the oven and check all functions.
E	<p><u>THERMAL CUT-OUT TEST 170°C (OVEN)</u></p> <ol style="list-style-type: none"> 1. Disconnect the power supply cord, and then remove outer case. 2. Open the door and block it open. 3. Discharge high voltage capacitor. 4. A continuity check across the thermal cut-out terminals should indicate a closed circuit unless the temperature of the thermal cut-out reaches approximately 338°F(170°C). The thermal cut-out resets automatically below approximately 311°F(155°C). An open thermal cut-out indicates overheating of the oven, check inside of oven cavity for improper setting of cooking time or operation of control unit. Check for restricted air flow through the vent holes of the oven cavity, especially the cooling fan and air guide. 5. Reconnect all leads removed from components during testing. 6. Reinstall the outer case (cabinet). 7. Reconnect the power supply cord after the outer case is installed. 8. Run the oven and check all functions. <p><u>THERMAL CUT-OUT TEST 125°C (MAGNETRON)</u></p> <ol style="list-style-type: none"> 1. Disconnect the power supply cord, and then remove outer case. 2. Open the door and block it open. 3. Discharge high voltage capacitor. 4. A continuity check across the thermal cut-out terminals should indicate a closed circuit. If the temperature of the magnetron reaches approximately 257°F(125°C), the thermal cut-out opens. An open thermal cut-out indicates overheating of the magnetron, exchange the thermal cut-out. Check for restricted air flow to the magnetron, especially the cooling fan air guide.

TEST PROCEDURES

PROCEDURE LETTER	COMPONENT TEST
	<ol style="list-style-type: none"> 5. Reconnect all leads removed from components during testing. 6. Reinstall the outer case (cabinet). 7. Reconnect the power supply cord after the outer case is installed. 8. Run the oven and check all functions. <p style="text-align: center;">CAUTION: IF THE THERMAL CUT-OUT INDICATES AN OPEN CIRCUIT AT ROOM TEMPERATURE, REPLACE THERMAL CUT-OUT.</p>
F	<p><u>SECONDARY INTERLOCK SWITCH TEST</u></p> <ol style="list-style-type: none"> 1. Disconnect the power supply cord, and then remove outer case. 2. Open the door and block it open. 3. Discharge high voltage capacitor. 4. Isolate the switch and connect the ohmmeter to the common (COM.) and normally open (NO) terminal of the switch. The meter should indicate an open circuit with the door open and a closed circuit with the door closed. If improper operation is indicated, replace the secondary interlock switch. 5. Reconnect all leads removed from components during testing. 6. Reinstall the outer case (cabinet). 7. Reconnect the power supply cord after the outer case is installed. 8. Run the oven and check all functions. <p><u>PRIMARY INTERLOCK SYSTEM TEST</u></p> <p><u>DOOR SENSING SWITCH</u></p> <ol style="list-style-type: none"> 1. Disconnect the power supply cord, and then remove outer case. 2. Open the door and block it open. 3. Discharge high voltage capacitor. 4. Isolate the switch and connect the ohmmeter to the common (COM.) and normally open (NO) terminal of the switch. The meter should indicate an open circuit with the door open and a closed circuit with the door closed. If improper operation is indicated, replace the door sensing switch. 5. Reconnect all leads removed from components during testing. 6. Reinstall the outer case (cabinet). 7. Reconnect the power supply cord after the outer case is installed. 8. Run the oven and check all functions. <p>NOTE: If the door sensing switch contacts fail in the open position and the door is closed, the cooling fan, turntable and oven light will be activated by relay(RY6).</p> <p><u>PRIMARY INTERLOCK RELAY (RY2)</u></p> <ol style="list-style-type: none"> 1. Disconnect the power supply cord, and then remove outer case. 2. Open the door and block it open. 3. Discharge high voltage capacitor. 4. Disconnect two (2) wire leads from the male tab terminals of the Primary Interlock Relay. Check the state of the relay contacts using a ohmmeter. The relay contacts should be open. If the relay contacts are closed, replace the circuit board entirely or the relay itself. 5. Reconnect all leads removed from components during testing. 6. Reinstall the outer case (cabinet). 7. Reconnect the power supply cord after the outer case is installed. 8. Run the oven and check all functions.
G	<p><u>MONITOR SWITCH TEST</u></p> <ol style="list-style-type: none"> 1. Disconnect the power supply cord, and then remove outer case. 2. Open the door and block it open. 3. Discharge high voltage capacitor. 4. Before performing this test, make sure that the secondary interlock switch and the primary interlock relay are operating properly, according to the above Switch Test Procedure. Disconnect the wire lead from the monitor switch (COM) terminal. Check the monitor switch operation by using the ohmmeter as follows. When the door is open, the meter should indicate a closed circuit. When the monitor switch actuator is pushed by a screw driver through the lower latch hole on the front plate of the oven cavity

TEST PROCEDURES

PROCEDURE LETTER

COMPONENT TEST

with the door opened (in this condition the plunger of the monitor switch is pushed in), the meter should indicate an open circuit. If improper operation is indicated, the switch may be defective. After testing the monitor switch, reconnect the wire lead to the monitor switch (COM) terminal and check the continuity of the monitor circuit.

5. Reconnect all leads removed from components during testing.
6. Reinstall the outer case (cabinet).
7. Reconnect the power supply cord after the outer case is installed.
8. Run the oven and check all functions.

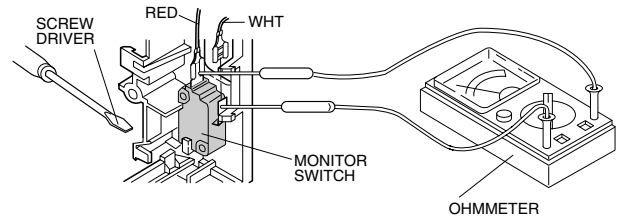

H

BLOWN MONITOR FUSE TEST

1. Disconnect the power supply cord, and then remove outer case.
2. Open the door and block it open.
3. Discharge high voltage capacitor.
4. If the monitor fuse is blown when the door is opened, check the primary interlock relay, secondary interlock switch and monitor switch according to the "TEST PROCEDURE" for those switches before replacing the blown monitor fuse.

CAUTION: BEFORE REPLACING A BLOWN MONITOR FUSE, TEST THE PRIMARY INTERLOCK RELAY, SECONDARY INTERLOCK SWITCH, DOOR SENSING SWITCH AND MONITOR SWITCH FOR PROPER OPERATION.

If the monitor fuse is blown by improper switch operation, the monitor fuse and monitor switch must be replaced with "monitor fuse and monitor switch assembly" part number FFS-BA021WRK0, even if the monitor switch operates normally. The monitor fuse and monitor switch assembly is comprised of a 20 ampere fuse and switch.

5. Reconnect all leads removed from components during testing.
6. Reinstall the outer case (cabinet).
7. Reconnect the power supply cord after the outer case is installed.
8. Run the oven and check all functions.

I

TOP HEATERS AND BOTTOM HEATER TEST

1. Disconnect the power supply cord, and then remove outer case.
2. Open the door and block it open.
3. Discharge high voltage capacitor.
4. Make sure the heater is cooled completely.
5. Resistance of heater.
Disconnect the wire leads to the heater to be tested. Using ohmmeter with low resistance range. Check the resistance across the terminals of the heater as described in the following table.

Table: Resistance of heater

Parts name	Resistance
Top heaters	Approximately $7.2 \Omega \times 2 = 14.4 \Omega$
Bottom heater	Approximately 28.8Ω

6. Insulation resistance.
Disconnect the wire leads to the heater to be tested. Check the insulation resistance between the heater terminal and cavity using a 500V - 100M Ω insulation tester. The insulation resistance should be more than 10 M Ω in the cold start.
7. If the results of above test 5 and/or 6 are out of above specifications, the heater is probably faulty and should be replaced.
8. Reconnect all leads removed from components during testing.
9. Reinstall the outer case (cabinet).

TEST PROCEDURES

PROCEDURE LETTER	COMPONENT TEST
	10.Reconnect the power supply cord after the outer case is installed. 11.Run the oven and check all functions.

J THERMISTOR TEST

1. Disconnect the power supply cord, and then remove outer case.
2. Open the door and block it open.
3. Discharge high voltage capacitor.
4. Disconnect connector-D from the control unit. Measure the resistance of the thermistor with an ohmmeter. Connect the ohmmeter leads to Pin No's D1 and D3.

Room Temperature	Resistance
68°F(20°C) - 86°F(30°C)	Approx. 293kΩ - 184KΩ

5. If the meter does not indicate above resistance, replace the thermistor
6. Reconnect all leads removed from components during testing.
7. Reinstall the outer case (cabinet).
8. Reconnect the power supply cord after the outer case is installed.
9. Run the oven and check all functions.

K CHECKING TEMPERATURE IN THE CONVECTION MODE

The following test procedure should be carried out with the microwave oven in a fully assembled condition (outer case fitted).

It is difficult to measure the exact temperature in the convection oven. An accurate thermocouple type temperature tester must be used. A low priced bi-metal type thermometer is not reliable or accurate. The temperature should be checked with outer case cabinet installed, approx. 5 minutes after preheat temperature is reached (audible signal sounds four times). The temperature experienced may be approx. 30°F more or less than indicated on the display, however, in most cases the food cooking results will be satisfactory.

Difference in power supply voltage will also affect the oven temperature. The Household power supply voltage may sometimes become lower than the rated voltage (120 V) and cause under-cooking. If the power supply voltage is 10% lower than the rated voltage, longer cooking time is required by 10% to 20%.

L TOUCH CONTROL PANEL ASSEMBLY TEST

The touch control panel consists of circuits including semiconductors such as LSI, ICs, etc. Therefore, unlike conventional microwave ovens, proper maintenance cannot be performed with only a voltmeter and ohmmeter.

In this service manual, the touch control panel assembly is divided into two units, Control Unit and Key Unit, and also the Control Unit is divided into two units, CPU Unit and Power Unit, and troubleshooting by unit replacement is described according to the symptoms indicated.

Before testing,

- 1) Disconnect the power supply cord, and then remove outer case.
 - 2) Open the door and block it open.
 - 3) Discharge high voltage capacitor.
 - 4) Disconnect the leads to the primary of the power transformer.
 - 5) Ensure that these leads remain isolated from other components and oven chassis by using insulation tape.
 - 6) After that procedure, re-connect the power supply cord.
1. Key Unit.

NOTE ;

- 1) Disconnect the power supply cord, and then remove outer case.
- 2) Open the door and block it open.
- 3) Discharge high voltage capacitor.
- 4) Check key unit ribbon connection before replacement.
- 5) Reconnect all leads removed from components during testing.

TEST PROCEDURES

PROCEDURE LETTER	COMPONENT TEST
	<ol style="list-style-type: none"> 6) Re-install the outer case (cabinet). 7) Reconnect the power supply cord after the outer case is installed. 8) Run the oven and check all functions. <p style="margin-left: 20px;">The following symptoms indicate a defective key unit.</p> <ol style="list-style-type: none"> a) When touching the pads, a certain pad produces no signal at all. b) When touching a number pad, two figures or more are displayed. c) When touching the pads, sometimes a pad produces no signal. <p>If the key unit is defective.</p> <ol style="list-style-type: none"> 1) Disconnect the power supply cord, and then remove outer case. 2) Open the door and block it open. 3) Discharge high voltage capacitor. 4) Replace the key unit. 5) Reconnect all leads removed from components during testing. 6) Re-install the outer case (cabinet). 7) Reconnect the power supply cord after the outer case is installed. 8) Run the oven and check all functions.
2.	<p>Control Unit.</p> <p>The following symptoms indicate a defective control unit. Before replacing the control unit, perform the Key unit test (Procedure M) to determine if control unit is faulty.</p>
2-1	<p>In connection with pads.</p> <ol style="list-style-type: none"> a) When touching the pads, a certain group of pads do not produce a signal. b) When touching the pads, no pads produce a signal.
2-2	<p>In connection with indicators</p> <ol style="list-style-type: none"> a) At a certain digit, all or some segments do not light up. b) At a certain digit, brightness is low. c) Only one indicator does not light. d) The corresponding segments of all digits do not light up; or they continue to light up. e) Wrong figure appears. f) A certain group of indicators do not light up. g) The figure of all digits flicker.
2-3	<p>Other possible problems caused by defective control unit.</p> <ol style="list-style-type: none"> a) Buzzer does not sound or continues to sound. b) Clock does not operate properly. c) Cooking is not possible. d) Proper temperature measurement is not obtained.
	<p>When testing is completed,</p> <ol style="list-style-type: none"> 1) Disconnect the power supply cord, and then remove outer case. 2) Open the door and block it open. 3) Discharge high voltage capacitor. 4) Reconnect all leads removed from components during testing. 5) Re-install the outer case (cabinet). 6) Reconnect the power supply cord after the outer case is installed. 7) Run the oven and check all functions.

M

KEY UNIT TEST

1. Disconnect the power supply cord, and then remove outer case.
2. Open the door and block it open.
3. Discharge high voltage capacitor.
4. If the display fails to clear when the STOP/CLEAR pad is depressed, first verify the flat ribbon cable is making good contact, verify that the door sensing switch (stop switch) operates properly; that is the contacts are closed when the door is closed and open when the door is open. If the door sensing switch (stop switch) is good, disconnect the flat ribbon cable that connects the key unit to the control unit and make sure the door sensing switch is closed (either close the door or short the door sensing switch connector). Use the Key unit matrix indicated on the control panel schematic and place a jumper wire between the pins that correspond to the STOP/CLEAR pad making momentary contact.

TEST PROCEDURES

PROCEDURE LETTER

COMPONENT TEST

If the control unit responds by clearing with a beep the key unit is faulty and must be replaced. If the control unit does not respond, it is faulty and must be replaced. If a specific pad does not respond, the above method may be used (after clearing the control unit) to determine if the control unit or key pad is at fault.

5. Reconnect all leads removed from components during testing.
6. Re-install the outer case (cabinet).
7. Reconnect the power supply cord after the outer case is installed.
8. Run the oven and check all functions.

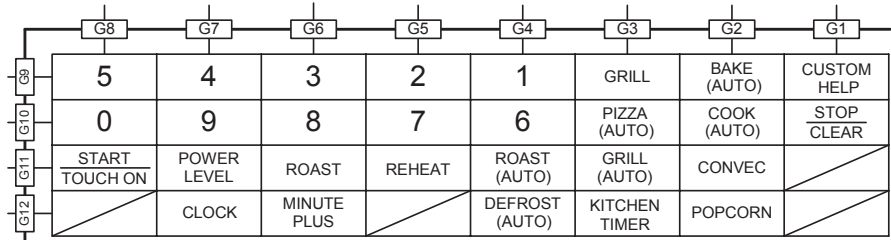

N RELAY TEST

1. Disconnect the power supply cord, and then remove outer case.
2. Open the door and block it open.
3. Discharge high voltage capacitor.
4. Disconnect the leads to the primary of the power transformer.
5. Ensure that these leads remain isolated from other components and oven chassis by using insulation tape.
6. After that procedure, re-connect the power supply cord.
7. Remove the outer case and check voltage between Pin No. 1 of the 3 pin connector (A) and the common terminal of the relay RY6 on the control unit with an A.C. voltmeter.
The meter should indicate 120 volts, if not check oven circuit.

Shut off, Cook and Heater Relay Test

These relays are operated by D.C. voltage

Check voltage at the relay coil with a D.C. voltmeter during the microwave cooking operation, grill cooking operation, or convection cooking operation.

DC. voltage indicated Defective relay.

DC. voltage not indicated Check diode which is connected to the relay coil. If diode is good, control unit is defective.

RELAY SYMBOL	OPERATIONAL VOLTAGE	CONNECTED COMPONENTS
RY1	Approx. 25.0V D.C.	Convection motor
RY2	Approx. 24.0V D.C.	Power transformer
RY3	Approx. 24.0V D.C.	Grill heaters (Top)
RY4	Approx. 24.0V D.C.	Bottom heater
RY5	Approx. 25.0V D.C.	Fan motor
RY6	Approx. 25.0V D.C.	Oven lamp / Turntable motor

8. Disconnect the power supply cord, and then remove outer case.
9. Open the door and block it open.
10. Discharge high voltage capacitor.
11. Reconnect all leads removed from components during testing.
12. Re-install the outer case (cabinet).
13. Reconnect the power supply cord after the outer case is installed.
14. Run the oven and check all functions.

O AUTO DEFROST TEST

WARNING : The oven should be fully assembled before following procedure.

- (1) Place one cup of water in the center of the turntable tray in the oven cavity.

TEST PROCEDURES

PROCEDURE LETTER

COMPONENT TEST

- (2) Close the door, touch the "Auto Defrost" pad once and touch the Number pad "1", and touch the Number pad 5. And then touch the "START" pad.
- (3) The oven is in Auto Defrost cooking condition.
- (4) The oven will operate as follows

WEIGHT (Ground meat)	1ST STAGE		2ND STAGE		3RD STAGE		4TH STAGE	
	LEVEL	TIME	LEVEL	TIME	LEVEL	TIME	LEVEL	TIME
0.5lb	70%	50sec.	0%	1min.	50%	35sec.	30%	45sec.

- (5) If improper operation is indicated, the control unit is probably defective and should be checked.

P

FOIL PATTERN ON THE PRINTED WIRING BOARD TEST

To protect the electronic circuits, this model is provided with a fine foil pattern added to the primary on the PWB, this foil pattern acts as a fuse.

1. Foil pattern check and repairs.
 - 1) Disconnect the power supply cord, and then remove outer case.
 - 2) Open the door and block it open.
 - 3) Discharge high voltage capacitor.
 - 4) Follow the troubleshooting guide given below for repair.

STEPS	OCCURRENCE	CAUSE OR CORRECTION
1	Only pattern at "a" is broken.	*Insert jumper wire J1 and solder.
2	Pattern at "a" and "b" are broken.	*Insert the coil RCILF2003YAZZ between "c" and "d".

- 5) Make a visual inspection of the varistor. Check for burned damage and examine the transformer with a tester for the presence of layer short-circuit (check the primary coil resistance which is approximately $176\Omega \pm 10\%$). If any abnormal condition is detected, replace the control unit.
- 6) Reconnect all leads removed from components during testing.
- 7) Re-install the outer case (cabinet).
- 8) Reconnect the power supply cord after the outer case is installed.
- 9) Run the oven and check all functions.
2. Follow the troubleshooting guide given below, if indicator does not light up after above check and repairs are finished.
 - 1) Disconnect the power supply cord, and then remove outer case.
 - 2) Open the door and block it open.
 - 3) Discharge high voltage capacitor.
 - 4) Disconnect the leads to the primary of the power transformer.
 - 5) Ensure that these leads remain isolated from other components and oven chassis by using insulation tape.
 - 6) After that procedure, re-connect the power supply cord.
 - 7) Follow the troubleshooting guide given below for repair.

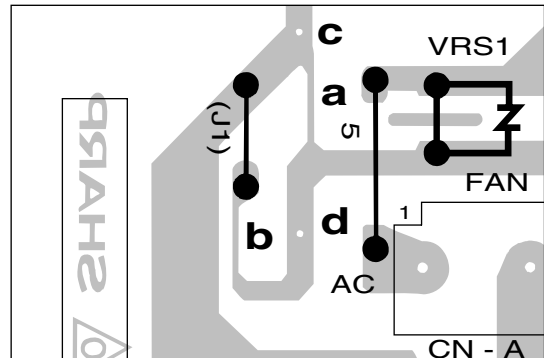

STEPS	OCCURRENCE	CAUSE OR CORRECTION
1	The rated AC voltage is not present between Pin No. 1 of the 3-pin connector (A) and the common terminal of the relay RY6.	Check supply voltage and oven power cord.
2	The rated AC voltage is present at primary side of low voltage transformer.	Low voltage transformer or secondary circuit defective. Check and replace the control unit.

- 8) Disconnect the power supply cord, and then remove outer case.

TEST PROCEDURES

PROCEDURE LETTER	COMPONENT TEST
	9) Open the door and block it open. 10) Discharge high voltage capacitor. 11) Reconnect all leads removed from components during testing. 12) Re-install the outer case (cabinet). 13) Reconnect the power supply cord after the outer case is installed. 14) Run the oven and check all functions.

TOUCH CONTROL PANEL ASSEMBLY

OUTLINE OF TOUCH CONTROL PANEL

The touch control section consists of the following units as shown in the touch control panel circuit.

- (1) Key Unit
- (2) Control Unit (The Control unit consists of Power unit and CPU unit.)

The principal functions of these units and signals communicated among them are explained below.

Key Unit

The key unit is composed of a matrix, signals generated in the LSI are sent to the key unit from P24, P25, P26, P27, P44, P45, P46 and P47.

When a key pad is touched, a signal is completed through the key unit and passed back to the LSI through P70 - P73 to perform the function that was requested.

Control Unit

Control unit consists of LSI, power source circuit, synchronizing signal circuit, reset circuit, buzzer circuit, relay circuit, temperature measurement circuit, indicator circuit and back light circuit.

1) LSI

This LSI controls the temperature measurement signal, key strobe signal, relay driving signal for oven function and indicator signal.

2) Power Source Circuit

This circuit generates voltage necessary in the control unit.

Symbol	Voltage	Application
VC	-5.2V	LSI(IC1)

3) Synchronizing Signal Circuit

The power source synchronizing signal is available in order to compose a basic standard time in the clock circuit. It accompanies a very small error because it works on commercial frequency.

4) Reset Circuit

A circuit to generate a signal which resets the LSI to the initial state when power is supplied.

5) Buzzer Circuit

The buzzer is responsive to signals from the LSI to emit audible sounds (key touch sound and completion sound).

6) Door Sensing Switch (Stop Switch)

A switch to "tell" the LSI if the door is open or closed.

7) Relay Circuit

To drive the magnetron, grill heaters, bottom heater, convection motor, fan motor, turntable motor and light the oven lamp.

8) Back Light Circuit

A circuit to drive the back light (Light emitting diodes LD1 - LD10).

9) Indicator Circuit

This circuit consists of 2line, 7-digits, 45-segments and 5-common electrodes using a Liquid Crystal Display.

10) Temperature Measurement Circuit : (OVEN THERMISTOR)

The temperature in the oven cavity is sensed by the thermistor. The variation of resistance according to sensed temperature is detected by the temperature measurement circuit and the result applied to LSI. The LSI uses this information to control the relay and display units.

DESCRIPTION OF LSI

LSI

The I/O signal of the LSI are detailed in the following table.

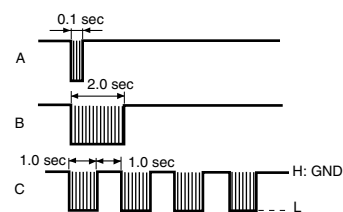
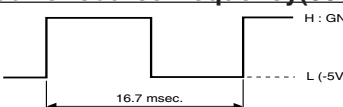
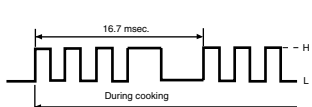
Pin No.	Signal	I/O	Description
1	C1	IN	Terminal not used.
2	VL1	IN	Power source voltage input terminal. Standard voltage for LCD.
3-6	AN7-AN4	IN	Heating constant compensation terminal.
7	AN3	IN	Temperature measurement input: OVEN THERMISTOR. By inputting DC voltage corresponding to the temperature detected by the thermistor, this input is converted into temperature by the A/D converter built into the LSI.
8	AN2	IN	Input signal which communicates the door open/close information to LSI. Door closed; "H" level signal. Door opened; "L" level signal.
9-10	AN1-AN0	IN	Terminal not used.
11	P57	OUT	Timing signal output terminal for temperature measurement(OVEN THERMISTOR). "H" level (GND) : Thermistor OPEN timing. "L" level (-5V) : Temperature measuring timing. (Convection cooking)
12	P56	IN	Terminal not used.
13	P55	OUT	Timing signal output terminal for temperature measurement(OVEN THERMISTOR). "H" level (GND) : Thermistor OPEN timing. "L" level (-5V) : Temperature measuring timing. (Convection cooking)
14-18	P54-P50	IN/OUT	Terminal not used.
19	P47	OUT	Key strobe signal. Signal applied to touch-key section. A pulse signal is input to P70 - P73 terminal while one of G8 line key on matrix is touched.
20	P46	OUT	Key strobe signal. Signal applied to touch-key section. A pulse signal is input to P70 - P73 terminal while one of G7 line key on matrix is touched.
21	P45	OUT	Key strobe signal. Signal applied to touch-key section. A pulse signal is input to P70 - P73 terminal while one of G6 line key on matrix is touched.
22	P44	OUT	Key strobe signal. Signal applied to touch-key section. A pulse signal is input to P70 - P73 terminal while one of G5 line key on matrix is touched.
23	P43	OUT	Signal to sound buzzer. A: key touch sound. B: Completion sound. C: When the temperature of the oven cavity reaches the preset temperature in the preheating mode, or when the preheating hold time (30 minutes) is elapsed. 
24	INT2	IN	Signal to synchronized LSI with commercial power source frequency(60Hz). This is basic timing for time processing of LSI. 
25	P41	OUT	Oven lamp and turntable motor driving signal(Square Waveform : 60Hz). To turn on and off shut-off relay (RY6). The square waveform voltage is delivered to the relay (RY6) driving circuit. 

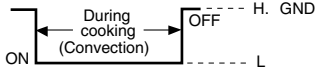
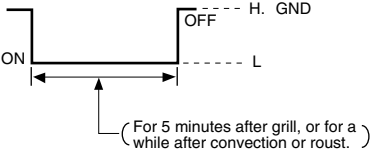
Pin No.	Signal	I/O	Description																																				
26	P40	OUT	<p>Bottom heater driving signal. To turn on and off the bottom relay (RY4). "L" level during grill (TOP AND BOTTOM) cooking, Convection cooking or Roast cooking, "H" level otherwise. The heater relay turns on and off within a 48 second time base in accordance with the special program in LSI.</p> <table border="1"> <thead> <tr> <th>Power output</th> <th>ON time</th> <th>OFF time</th> </tr> </thead> <tbody> <tr><td>100 %</td><td>48 sec.</td><td>0 sec.</td></tr> <tr><td>90 %</td><td>44 sec.</td><td>4 sec.</td></tr> <tr><td>80 %</td><td>40 sec.</td><td>8 sec.</td></tr> <tr><td>70 %</td><td>36 sec.</td><td>12 sec.</td></tr> <tr><td>60 %</td><td>32 sec.</td><td>16 sec.</td></tr> <tr><td>50 %</td><td>26 sec.</td><td>22 sec.</td></tr> <tr><td>40 %</td><td>22 sec.</td><td>26 sec.</td></tr> <tr><td>30 %</td><td>16 sec.</td><td>32 sec.</td></tr> <tr><td>20 %</td><td>12 sec.</td><td>36 sec.</td></tr> <tr><td>10 %</td><td>8 sec.</td><td>40 sec.</td></tr> </tbody> </table>	Power output	ON time	OFF time	100 %	48 sec.	0 sec.	90 %	44 sec.	4 sec.	80 %	40 sec.	8 sec.	70 %	36 sec.	12 sec.	60 %	32 sec.	16 sec.	50 %	26 sec.	22 sec.	40 %	22 sec.	26 sec.	30 %	16 sec.	32 sec.	20 %	12 sec.	36 sec.	10 %	8 sec.	40 sec.			
Power output	ON time	OFF time																																					
100 %	48 sec.	0 sec.																																					
90 %	44 sec.	4 sec.																																					
80 %	40 sec.	8 sec.																																					
70 %	36 sec.	12 sec.																																					
60 %	32 sec.	16 sec.																																					
50 %	26 sec.	22 sec.																																					
40 %	22 sec.	26 sec.																																					
30 %	16 sec.	32 sec.																																					
20 %	12 sec.	36 sec.																																					
10 %	8 sec.	40 sec.																																					
27	P77	OUT	<p>Convection motor driving signal. To turn on and off shut-off relay(RY1). "L" level during CONVECTION; "H" level otherwise. (Relay RY1 does not turn on at preheating mode.)</p> 																																				
28	P76	OUT	<p>Fan motor driving signal. To turn on and off the fan motor relay RY5. "L" level during cooking, or for 5 minutes after grill cooking or for a while after convection or roust cooking. "H" level otherwise.</p> 																																				
29	P75	OUT	<p>Grill heaters (TOP HEATER) driving signal. To turn on and off the grill heaters relay (RY3). "L" level during grill (TOP GRILL, TOP AND BOTTOM) cooking, Convection cooking or Roast cooking, "H" level otherwise. The heater relay turns on and off within a 48 second time base in accordance with the special program in LSI.</p> <table border="1"> <thead> <tr> <th>Power output</th> <th>ON time</th> <th>OFF time</th> </tr> </thead> <tbody> <tr><td>100 %</td><td>48 sec.</td><td>0 sec.</td></tr> <tr><td>90 %</td><td>44 sec.</td><td>4 sec.</td></tr> <tr><td>80 %</td><td>40 sec.</td><td>8 sec.</td></tr> <tr><td>70 %</td><td>36 sec.</td><td>12 sec.</td></tr> <tr><td>60 %</td><td>32 sec.</td><td>16 sec.</td></tr> <tr><td>50 %</td><td>26 sec.</td><td>22 sec.</td></tr> <tr><td>40 %</td><td>22 sec.</td><td>26 sec.</td></tr> <tr><td>30 %</td><td>16 sec.</td><td>32 sec.</td></tr> <tr><td>20 %</td><td>12 sec.</td><td>36 sec.</td></tr> <tr><td>10 %</td><td>8 sec.</td><td>40 sec.</td></tr> </tbody> </table>	Power output	ON time	OFF time	100 %	48 sec.	0 sec.	90 %	44 sec.	4 sec.	80 %	40 sec.	8 sec.	70 %	36 sec.	12 sec.	60 %	32 sec.	16 sec.	50 %	26 sec.	22 sec.	40 %	22 sec.	26 sec.	30 %	16 sec.	32 sec.	20 %	12 sec.	36 sec.	10 %	8 sec.	40 sec.			
Power output	ON time	OFF time																																					
100 %	48 sec.	0 sec.																																					
90 %	44 sec.	4 sec.																																					
80 %	40 sec.	8 sec.																																					
70 %	36 sec.	12 sec.																																					
60 %	32 sec.	16 sec.																																					
50 %	26 sec.	22 sec.																																					
40 %	22 sec.	26 sec.																																					
30 %	16 sec.	32 sec.																																					
20 %	12 sec.	36 sec.																																					
10 %	8 sec.	40 sec.																																					
30	P74	OUT	<p>Magnetron high-voltage circuit driving signal. To turn on and off the cook relay (RY2). In HIGH POWER operation, the signals hold "L" level during microwave cooking and "H" level while not cooking. In other cooking modes (90%, 80%, 70%, 60%, 50%, 40%, 30%, 20%, 10%, 0%) the signal turns to "H" level and "L" level in repetition according to the power level.</p> <table border="1"> <thead> <tr> <th>VARI</th> <th>ON TIME</th> <th>OFF TIME</th> </tr> </thead> <tbody> <tr><td>HIGH POWER</td><td>32 sec.</td><td>0 sec.</td></tr> <tr><td>90%</td><td>30 sec.</td><td>2 sec.</td></tr> <tr><td>80%</td><td>26 sec.</td><td>6 sec.</td></tr> <tr><td>70%</td><td>24 sec.</td><td>8 sec.</td></tr> <tr><td>60%</td><td>22 sec.</td><td>10 sec.</td></tr> <tr><td>50%</td><td>18 sec.</td><td>14 sec.</td></tr> <tr><td>40%</td><td>16 sec.</td><td>16 sec.</td></tr> <tr><td>30%</td><td>12 sec.</td><td>20 sec.</td></tr> <tr><td>20%</td><td>8 sec.</td><td>24 sec.</td></tr> <tr><td>10%</td><td>6 sec.</td><td>26 sec.</td></tr> <tr><td>0%</td><td>0 sec.</td><td>32 sec.</td></tr> </tbody> </table>	VARI	ON TIME	OFF TIME	HIGH POWER	32 sec.	0 sec.	90%	30 sec.	2 sec.	80%	26 sec.	6 sec.	70%	24 sec.	8 sec.	60%	22 sec.	10 sec.	50%	18 sec.	14 sec.	40%	16 sec.	16 sec.	30%	12 sec.	20 sec.	20%	8 sec.	24 sec.	10%	6 sec.	26 sec.	0%	0 sec.	32 sec.
VARI	ON TIME	OFF TIME																																					
HIGH POWER	32 sec.	0 sec.																																					
90%	30 sec.	2 sec.																																					
80%	26 sec.	6 sec.																																					
70%	24 sec.	8 sec.																																					
60%	22 sec.	10 sec.																																					
50%	18 sec.	14 sec.																																					
40%	16 sec.	16 sec.																																					
30%	12 sec.	20 sec.																																					
20%	8 sec.	24 sec.																																					
10%	6 sec.	26 sec.																																					
0%	0 sec.	32 sec.																																					
31	P73	IN	<p>Signal coming from touch key. When any one of G12 line keys on key matrix is touched, a corresponding signal from P24, P25, P26, P27, P44, P45, P46 and P47 will be input into P73. When no key is touched, the signal is held at "L" level.</p>																																				
32	P72	IN	<p>Signal similar to P73. When any one of G11 line keys on key matrix is touched, a corresponding signal will be input into P72.</p>																																				
33	P71	IN	<p>Signal similar to P73. When any one of G10 line keys on key matrix is touched, a corresponding signal will be input into P71.</p>																																				
34	P70	IN	<p>Signal similar to P73. When any one of G9 line keys on key matrix is touched, a corresponding signal will be input into P70.</p>																																				

Pin No.	Signal	I/O	Description																																																																																																
35	RESET	IN	Auto clear terminal. Signal is input to reset the LSI to the initial state when power is applied. Temporarily set to "L" level the moment power is applied, at this time the LSI is reset. Thereafter set at "H" level.																																																																																																
36	XCIN	IN	Terminal not used.																																																																																																
37	XOUT	IN	Terminal not used.																																																																																																
38	XIN	IN	Internal clock oscillation frequency input setting. The internal clock frequency is set by inserting the ceramic filter oscillation circuit with respect to OUT terminal.																																																																																																
39	XOUT	OUT	Internal clock oscillation frequency control output. Output to control oscillation input of XIN.																																																																																																
40	VSS	IN	Power source voltage: -5V. VC voltage of power source circuit input.																																																																																																
41	P27	OUT	Key strobe signal. Signal applied to touch-key section. A pulse signal is input to P70 - P73 terminal while one of G4 line key on matrix is touched.																																																																																																
42	P26	OUT	Key strobe signal. Signal applied to touch-key section. A pulse signal is input to P70 - P73 terminal while one of G3 line key on matrix is touched.																																																																																																
43	P25	OUT	Key strobe signal. Signal applied to touch-key section. A pulse signal is input to P70 - P73 terminal while one of G2 line key on matrix is touched.																																																																																																
44	P24	OUT	Key strobe signal. Signal applied to touch-key section. A pulse signal is input to P70 - P73 terminal while one of G1 line key on matrix is touched.																																																																																																
45	P23	OUT	Common data signal: COM5. Connected to LCD (Pin No. 37)																																																																																																
46-50	P22 - P16	OUT	Segment data signal. Connected to LCD. The relation between signals are as follows: <table border="0" style="width: 100%; border-collapse: collapse;"> <thead> <tr> <th style="text-align: left;">LSI signal (Pin No.)</th> <th style="text-align: left;">LCD (Pin No.)</th> <th style="text-align: left;">LSI signal (Pin No.)</th> <th style="text-align: left;">LCD (Pin No.)</th> </tr> </thead> <tbody> <tr><td>SEG 0 (90)</td><td>SEG45 (51)</td><td>SEG23 (67)</td><td>SEG17 (17)</td></tr> <tr><td>SEG 1 (89)</td><td>SEG44 (50)</td><td>SEG24 (66)</td><td>SEG16 (16)</td></tr> <tr><td>SEG 2 (88)</td><td>SEG43 (49)</td><td>SEG25 (65)</td><td>SEG15 (15)</td></tr> <tr><td>SEG 3 (87)</td><td>SEG42 (48)</td><td>SEG25 (65)</td><td>SEG15 (32)</td></tr> <tr><td>SEG 4 (86)</td><td>SEG41 (47)</td><td>SEG26 (64)</td><td>SEG14 (14)</td></tr> <tr><td>SEG 5 (85)</td><td>SEG40 (46)</td><td>SEG27 (63)</td><td>SEG13 (13)</td></tr> <tr><td>SEG 6 (84)</td><td>SEG39 (45)</td><td>SEG28 (62)</td><td>SEG12 (12)</td></tr> <tr><td>SEG 7 (83)</td><td>SEG38 (44)</td><td>SEG29 (61)</td><td>SEG11 (11)</td></tr> <tr><td>SEG 8 (82)</td><td>SEG37 (43)</td><td>SEG30 (60)</td><td>SEG10 (10)</td></tr> <tr><td>SEG 9 (81)</td><td>SEG31 (31)</td><td>SEG31 (59)</td><td>SEG 9 (9)</td></tr> <tr><td>SEG10 (80)</td><td>SEG30 (30)</td><td>SEG32 (58)</td><td>SEG 8 (8)</td></tr> <tr><td>SEG11 (79)</td><td>SEG29 (29)</td><td>SEG33 (57)</td><td>SEG 7 (7)</td></tr> <tr><td>SEG12 (78)</td><td>SEG28 (28)</td><td>SEG34 (56)</td><td>SEG 6 (6)</td></tr> <tr><td>SEG13 (77)</td><td>SEG27 (27)</td><td>SEG35 (55)</td><td>SEG 5 (5)</td></tr> <tr><td>SEG14 (76)</td><td>SEG26 (26)</td><td>SEG36 (54)</td><td>SEG 4 (4)</td></tr> <tr><td>SEG15 (75)</td><td>SEG25 (25)</td><td>SEG37 (53)</td><td>SEG 3 (3)</td></tr> <tr><td>SEG16 (74)</td><td>SEG24 (24)</td><td>SEG38 (52)</td><td>SEG 2 (2)</td></tr> <tr><td>SEG17 (73)</td><td>SEG23 (23)</td><td>SEG39 (51)</td><td>SEG 1 (1)</td></tr> <tr><td>SEG18 (72)</td><td>SEG22 (22)</td><td>P16 (50)</td><td>SEG32 (38)</td></tr> <tr><td>SEG19 (71)</td><td>SEG21 (21)</td><td>P17 (49)</td><td>SEG33 (39)</td></tr> <tr><td>SEG20 (70)</td><td>SEG20 (20)</td><td>P20 (48)</td><td>SEG34 (40)</td></tr> <tr><td>SEG21 (69)</td><td>SEG19 (19)</td><td>P21 (47)</td><td>SEG35 (41)</td></tr> <tr><td>SEG22 (68)</td><td>SEG18 (18)</td><td>P22 (46)</td><td>SEG36 (42)</td></tr> </tbody> </table>	LSI signal (Pin No.)	LCD (Pin No.)	LSI signal (Pin No.)	LCD (Pin No.)	SEG 0 (90)	SEG45 (51)	SEG23 (67)	SEG17 (17)	SEG 1 (89)	SEG44 (50)	SEG24 (66)	SEG16 (16)	SEG 2 (88)	SEG43 (49)	SEG25 (65)	SEG15 (15)	SEG 3 (87)	SEG42 (48)	SEG25 (65)	SEG15 (32)	SEG 4 (86)	SEG41 (47)	SEG26 (64)	SEG14 (14)	SEG 5 (85)	SEG40 (46)	SEG27 (63)	SEG13 (13)	SEG 6 (84)	SEG39 (45)	SEG28 (62)	SEG12 (12)	SEG 7 (83)	SEG38 (44)	SEG29 (61)	SEG11 (11)	SEG 8 (82)	SEG37 (43)	SEG30 (60)	SEG10 (10)	SEG 9 (81)	SEG31 (31)	SEG31 (59)	SEG 9 (9)	SEG10 (80)	SEG30 (30)	SEG32 (58)	SEG 8 (8)	SEG11 (79)	SEG29 (29)	SEG33 (57)	SEG 7 (7)	SEG12 (78)	SEG28 (28)	SEG34 (56)	SEG 6 (6)	SEG13 (77)	SEG27 (27)	SEG35 (55)	SEG 5 (5)	SEG14 (76)	SEG26 (26)	SEG36 (54)	SEG 4 (4)	SEG15 (75)	SEG25 (25)	SEG37 (53)	SEG 3 (3)	SEG16 (74)	SEG24 (24)	SEG38 (52)	SEG 2 (2)	SEG17 (73)	SEG23 (23)	SEG39 (51)	SEG 1 (1)	SEG18 (72)	SEG22 (22)	P16 (50)	SEG32 (38)	SEG19 (71)	SEG21 (21)	P17 (49)	SEG33 (39)	SEG20 (70)	SEG20 (20)	P20 (48)	SEG34 (40)	SEG21 (69)	SEG19 (19)	P21 (47)	SEG35 (41)	SEG22 (68)	SEG18 (18)	P22 (46)	SEG36 (42)
LSI signal (Pin No.)	LCD (Pin No.)	LSI signal (Pin No.)	LCD (Pin No.)																																																																																																
SEG 0 (90)	SEG45 (51)	SEG23 (67)	SEG17 (17)																																																																																																
SEG 1 (89)	SEG44 (50)	SEG24 (66)	SEG16 (16)																																																																																																
SEG 2 (88)	SEG43 (49)	SEG25 (65)	SEG15 (15)																																																																																																
SEG 3 (87)	SEG42 (48)	SEG25 (65)	SEG15 (32)																																																																																																
SEG 4 (86)	SEG41 (47)	SEG26 (64)	SEG14 (14)																																																																																																
SEG 5 (85)	SEG40 (46)	SEG27 (63)	SEG13 (13)																																																																																																
SEG 6 (84)	SEG39 (45)	SEG28 (62)	SEG12 (12)																																																																																																
SEG 7 (83)	SEG38 (44)	SEG29 (61)	SEG11 (11)																																																																																																
SEG 8 (82)	SEG37 (43)	SEG30 (60)	SEG10 (10)																																																																																																
SEG 9 (81)	SEG31 (31)	SEG31 (59)	SEG 9 (9)																																																																																																
SEG10 (80)	SEG30 (30)	SEG32 (58)	SEG 8 (8)																																																																																																
SEG11 (79)	SEG29 (29)	SEG33 (57)	SEG 7 (7)																																																																																																
SEG12 (78)	SEG28 (28)	SEG34 (56)	SEG 6 (6)																																																																																																
SEG13 (77)	SEG27 (27)	SEG35 (55)	SEG 5 (5)																																																																																																
SEG14 (76)	SEG26 (26)	SEG36 (54)	SEG 4 (4)																																																																																																
SEG15 (75)	SEG25 (25)	SEG37 (53)	SEG 3 (3)																																																																																																
SEG16 (74)	SEG24 (24)	SEG38 (52)	SEG 2 (2)																																																																																																
SEG17 (73)	SEG23 (23)	SEG39 (51)	SEG 1 (1)																																																																																																
SEG18 (72)	SEG22 (22)	P16 (50)	SEG32 (38)																																																																																																
SEG19 (71)	SEG21 (21)	P17 (49)	SEG33 (39)																																																																																																
SEG20 (70)	SEG20 (20)	P20 (48)	SEG34 (40)																																																																																																
SEG21 (69)	SEG19 (19)	P21 (47)	SEG35 (41)																																																																																																
SEG22 (68)	SEG18 (18)	P22 (46)	SEG36 (42)																																																																																																

Pin No.	Signal	I/O	Description
51-90	SEG39-SEG0	OUT	Segment data signal. Connected to LCD. No connection in LCD.
91	VCC	IN	Connected to GND.
92	VREF	IN	Connected to GND.
93	AVSS	IN	Connected to VC.
94	COM3	OUT	Common data signal: COM4. Connected to LCD (Pin No. 36).
95	COM2	OUT	Common data signal: COM3. Connected to LCD (Pin No. 35).
96	COM1	OUT	Common data signal: COM2. Connected to LCD (Pin No. 34).
97	COM0	OUT	Common data signal: COM1. Connected to LCD (Pin No. 33).
98-99	VL3-VL2	IN	Power source voltage input terminal. Standard voltage for LCD.
100	C2	IN	Terminal not used.

SERVICING

1. Precautions for Handling Electronic Components

This unit uses CMOS LSI in the integral part of the circuits. When handling these parts, the following precautions should be strictly followed. CMOS LSI have extremely high impedance at its input and output terminals. For this reason, it is easily influenced by the surrounding high voltage power source, static electricity charge in clothes, etc., and sometimes it is not fully protected by the built-in protection circuit.

In order to protect CMOS LSI.

- 1) When storing and transporting, thoroughly wrap them in aluminium foil. Also wrap PW boards containing them in aluminium foil.
- 2) When soldering, ground the technician as shown in the figure and use grounded soldering iron and work table.

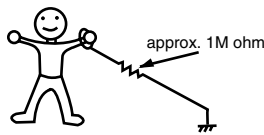

2. Servicing of Touch Control Panel

We describe the procedures to permit servicing of the touch control panel of the microwave oven and the precautions you must take when doing so.

To perform the servicing, power to the touch control panel is available either from the power line of the oven itself or from an external power source.

(1) Servicing the touch control panel with power supply of the oven :

CAUTION:

THE HIGH VOLTAGE TRANSFORMER OF THE MICROWAVE OVEN IS STILL LIVE DURING SERVICING AND PRESENTS A HAZARD .

Therefore, before checking the performance of the touch control panel,

- 1) Disconnect the power supply cord, and then remove outer case.
 - 2) Open the door and block it open.
 - 3) Discharge high voltage capacitor.
 - 4) Disconnect the leads to the primary of the power transformer.
 - 5) Ensure that these leads remain isolated from other components and oven chassis by using insulation tape.
 - 6) After that procedure, re-connect the power supply cord.
- After checking the performance of the touch control panel,
- 1) Disconnect the power supply cord.
 - 2) Open the door and block it open.
 - 3) Re-connect the leads to the primary of the power transformer.
 - 4) Re-install the outer case (cabinet).
 - 5) Re-connect the power supply cord after the outer case is installed.
 - 6) Run the oven and check all functions.

- A. On some models, the power supply cord between the touch control panel and the oven itself is so short that the two can't be separated.

For those models, check and repair all the controls (sensor-related ones included) of the touch control panel while keeping it connected to the oven.

- B. On some models, the power supply cord between the touch control panel and the oven proper is long enough that they may be separated from each other. For those models, therefore, it is possible to check and repair the controls of the touch control panel while keeping it apart from the oven proper; in this case you must short both ends of the door sensing switch (on PWB) of the touch control panel with a jumper, which brings about an operational state that is equivalent to the oven door being closed. As for the sensor-related controls of the touch control panel, checking them is possible if the dummy resistor(s) with resistance equal to that of the controls are used.

(2) Servicing the touch control panel with power supply from an external power source:

Disconnect the touch control panel completely from the oven proper, and short both ends of the door sensing switch (on PWB) of the touch control panel, which brings about an operational state that is equivalent to the oven door being closed. Connect an external power source to the power input terminal of the touch control panel, then it is possible to check and repair the controls of the touch control panel; it is also possible to check the sensor-related controls of the touch control panel by using the dummy resistor(s).

3. Servicing Tools

Tools required to service the touch control panel assembly.

- 1) Soldering iron: 30W
(It is recommended to use a soldering iron with a grounding terminal.)
- 2) Oscilloscope: Single beam, frequency range: DC - 10MHz type or more advanced model.
- 3) Others: Hand tools

4. Other Precautions

- 1) Before turning on the power source of the control unit, remove the aluminium foil applied for preventing static electricity.
- 2) Connect the connector of the key unit to the control unit being sure that the lead wires are not twisted.
- 3) After aluminium foil is removed, be careful that abnormal voltage due to static electricity etc. is not applied to the input or output terminals.
- 4) Attach connectors, electrolytic capacitors, etc. to PWB, making sure that all connections are tight.
- 5) Be sure to use specified components where high precision is required.

PRECAUTIONS FOR USING LEAD-FREE SOLDER

1. Employing lead-free solder

The "Control unit PWB" of this model employs lead-free solder. This is indicated by the "LF" symbol printed on the PWB and in the service manual. The suffix letter indicates the alloy type of the solder.

Example:



LF a

Sn-Ag-Cu

Indicates lead-free solder of tin, silver and copper.

2. Using lead-free wire solder

When repairing a PWB with the "LF" symbol, only lead-free solder should be used. (Using normal tin/lead alloy solder may result in cold soldered joints and damage to printed patterns.)

As the melting point of lead-free solder is approximately 40°C higher than tin/lead alloy solder, it is recommend that a dedicated bit is used, and that the iron temperature is adjusted accordingly.

3. Soldering

As the melting point of lead-free solder (Sn-Ag-Cu) is higher and has poorer wettability, (flow), to prevent damage to the land of the PWB, extreme care should be taken not to leave the bit in contact with the PWB for an extended period of time. Remove the bit as soon as a good flow is achieved. The high content of tin in lead free solder will cause premature corrosion of the bit. To reduce wear on the bit, reduce the temperature or turn off the iron when it is not required.

Leaving different types of solder on the bit will cause contamination of the different alloys, which will alter their characteristics, making good soldering more difficult. It will be necessary to clean and replace bits more often when using lead-free solder. To reduce bit wear, care should be taken to clean the bit thoroughly after each use.

COMPONENT REPLACEMENT AND ADJUSTMENT PROCEDURE

WARNING AGAINST HIGH VOLTAGE:

Microwave ovens contain circuitry capable of producing very high voltage and current, contact with following parts may result in severe, possibly fatal, electric shock.

(Example)

High Voltage Capacitor, Power Transformer, Magnetron, High Voltage Rectifier Assembly, High Voltage Harness etc..

WARNING: Avoid possible exposure to microwave energy. Please follow the instructions below before operating the oven.

- | | |
|--|--|
| <ol style="list-style-type: none"> 1. Disconnect the power supply cord. 2. Make sure that a definite "click" can be heard when the microwave oven door is unlatched. (Hold the door in a closed position with one hand, then push the door open button with the other, this causes the latch leads to rise, it is then possible to hear a "click" as the door switches operate.) 3. Visually check the door and cavity face plate for damage (dents, cracks, signs of arcing etc.). | <ol style="list-style-type: none"> 1. Door does not close firmly. 2. Door hinge, support or latch hook is damaged. 3. The door gasket or seal is damaged. 4. The door is bent or warped. 5. There are defective parts in the door interlock system. 6. There are defective parts in the microwave generating and transmission assembly. 7. There is visible damage to the oven. |
|--|--|

Carry out any remedial work that is necessary before operating the oven.

Do not operate the oven if any of the following conditions exist;

Do not operate the oven:

1. Without the RF gasket (Magnetron).
2. If the wave guide or oven cavity are not intact.
3. If the door is not closed.
4. If the outer case (cabinet) is not fitted.

WARNING FOR WIRING

To prevent an electric shock, take the following precautions.

- | | |
|--|--|
| <ol style="list-style-type: none"> 1. Before wiring, <ol style="list-style-type: none"> 1) Disconnect the power supply cord. 2) Open the door and block it open. 3) Discharge the high voltage capacitor and wait for 60 seconds. 2. Don't let the wire leads touch to the following parts; <ol style="list-style-type: none"> 1) High voltage parts:
Magnetron, High voltage transformer, High voltage capacitor and High voltage rectifier assembly. 2) Hot parts:
Oven lamp, Magnetron, High voltage transformer, grill heater, bottom heater and Oven cavity. | <ol style="list-style-type: none"> 3) Sharp edge:
Bottom plate, Oven cavity, Waveguide flange, Chassis support and other metallic plate. 4) Movable parts (to prevent a fault)
Fan blade, Fan motor, Switch, Switch lever, Open button. 3. Do not catch the wire leads in the outer case cabinet. 4. Insert the positive lock connector until its pin is locked and make sure that the wire leads do not come off even if the wire leads are pulled. 5. To prevent an error function, connect the wire leads correctly, referring to the Pictorial Diagram. |
|--|--|

Please refer to 'OVEN PARTS, CABINET PARTS, CONTROL PANEL PARTS, DOOR PARTS', when carrying out any of the following removal procedures:

OUTER CASE REMOVAL

To remove the outer case, proceed as follows.

- | | |
|---|---|
| <ol style="list-style-type: none"> 1. Disconnect the power supply cord. 2. Open the oven door and block it open. 3. Remove the two (2) screws holding the back plate to the oven cavity rear plate. 4. Remove the back plate with the sub back plate. 5. Remove the two (2) screws from the lower portion of the | <p>rear cabinet using a T20H Torx type or GTXH20-100 screw driver.</p> <ol style="list-style-type: none"> 6. Remove the remaining three (3) screws from rear and along the side edge of case. 7. Slide the entire case back about 3cm to free it from retaining clips on the cavity face plate. 8. Lift the entire case from the oven. |
|---|---|

9. Discharge the H.V. capacitor before carrying out any further work.
 10. Do not operate the oven with the outer case removed.
- CAUTION:** 1. DISCONNECT OVEN FROM POWER SUPPLY BEFORE REMOVING OUTER CASE.
2. DISCHARGE THE HIGH VOLTAGE CAPACITOR BEFORE TOUCHING ANY OVEN COMPONENTS OR WIRING.

NOTE: When replacing the outer case, the 2 special Torx screws must be reinstalled in the same locations.

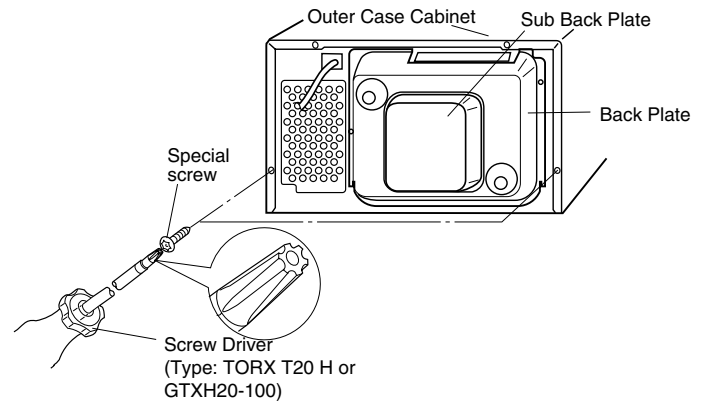

POWER TRANSFORMER REMOVAL

1. Disconnect the power supply cord and then remove outer case.
2. Open the oven door and block it open.
3. Discharge high voltage capacitor.
4. Disconnect the filament leads of power transformer from high voltage capacitor and the magnetron.
5. Disconnect the H.V. wire B from the power transformer.
6. Disconnect the main wire harness from the power transformer.
7. Remove the two (2) screws holding the transformer to base plate.
8. Remove the transformer.
9. Now the power transformer is free.

HIGH VOLTAGE RECTIFIER ASSEMBLY AND HIGH VOLTAGE CAPACITOR REMOVAL

To remove the components, proceed as follows.

1. Disconnect the power supply cord and then remove outer case.
2. Open the door and block it open.
3. Discharge high voltage capacitor.
4. Disconnect H.V. wire of the high voltage rectifier assembly from the magnetron.
5. Disconnect all the leads and terminals of high voltage rectifier assembly from the high voltage capacitor.
6. Remove one (1) screw holding earth side terminal of the high voltage rectifier assembly.
7. Now, the high voltage rectifier assembly should be free.
8. Remove one (1) screw holding capacitor holder to the oven cavity rear plate.
9. Release the capacitor holder from the fan duct.
10. Remove the capacitor from the capacitor holder.
11. Now, the capacitor should be free.

CAUTION: WHEN REPLACING HIGH VOLTAGE RECTIFIER AND HIGH VOLTAGE CAPACITOR, GROUND SIDE TERMINAL OF THE HIGH VOLTAGE RECTIFIER MUST BE SECURED FIRMLY WITH A GROUNDING SCREW.

MAGNETRON REMOVAL

1. Disconnect the power supply cord and remove outer case.
2. Open the door and block it open.
3. Discharge high voltage capacitor.
4. Release the tabs of air intake duct from the chassis support and the oven cavity.
5. Disconnect the high voltage wire of the high voltage rectifier assembly and filament lead of the transformer from the magnetron.
6. Remove the one (1) screw holding the chassis support to the magnetron.
7. Move the air intake duct to the left.
8. Carefully remove four (4) screws holding magnetron to waveguide, when removing the screws hold the magnetron to prevent it from falling.
9. Remove the magnetron from the waveguide with care so the magnetron antenna is not hit by any metal object around the antenna.

CAUTION: WHEN REPLACING THE MAGNETRON, BE SURE THE R.F. GASKET IS IN PLACE AND THE MAGNETRON MOUNTING SCREWS ARE TIGHTENED SECURELY.

CONTROL PANEL ASSEMBLY REMOVAL

CONTROL PANEL ASSEMBLY

1. Disconnect the power supply cord and then remove outer case.
2. Open the door and block it open.
3. Discharge high voltage capacitor.
4. Disconnect the main wire harness, thermistor harness and the switch harness from the power unit.
5. Straighten the tab of the oven cavity front flange holding the tab of the control panel frame.
6. Remove the one (1) screw holding the control panel

frame to the oven cavity front plate.

7. Lift up the control panel assembly.
8. Now, the control panel assembly is free.

CONTROL UNIT

9. Disconnect the flat ribbon cable from the connector CN-G.
10. Remove the four (4) screws holding the control unit to the control panel frame.
11. Release the two (2) tabs of the control panel frame holding the CPU unit of the control unit to the control panel frame.
12. Release the four (4) tabs of the control panel frame

holding the power unit of the control unit to the control panel frame.

13. Now, the control unit is free.

- NOTE:**
1. Before attaching a new key unit, wipe off remaining adhesive on the control panel frame surfaces completely with a soft cloth soaked in alcohol.
 2. When attaching the key unit to the control panel frame, adjust the upper edge and right edge of the key unit to the correct position of control panel frame.
 3. Stick the key unit firmly to the control panel frame by rubbing with soft cloth not to scratch.

OVEN LAMP AND LAMP SOCKET REMOVAL

1. Disconnect the power supply cord and then remove outer case.
2. Open the door and block it open.
3. Discharge high voltage capacitor.
4. Lift up the oven lamp socket from air intake duct.
5. Pull the wire leads from the oven lamp socket by pushing the terminal hole of the oven lamp socket with the small flat type screw driver.
6. Now, the oven lamp socket is free.

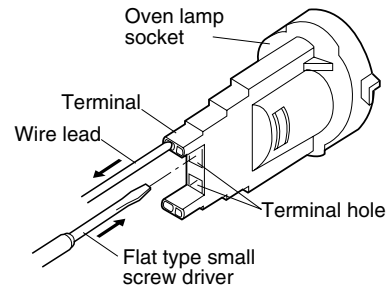

Figure C-1. Oven lamp socket

POSITIVE LOCK® CONNECTOR (NO-CASE TYPE) REMOVAL

1. Disconnect the power supply cord and then remove outer case.
2. Open the door and block it open.
3. Discharge high voltage capacitor.
4. Push the lever of positive lock® connector.
5. Pull down on the positive lock® connector.

CAUTION: WHEN CONNECTING THE POSITIVE LOCK® CONNECTORS TO THE TERMINALS, INSTALL THE POSITIVE LOCK® SO THAT THE LEVER FACES YOU.

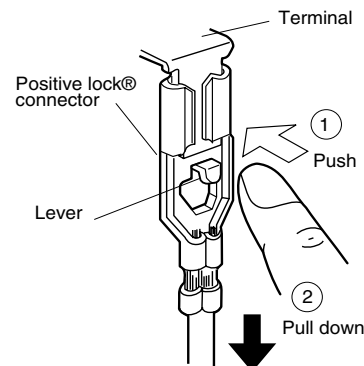

Figure C-2. Positive lock® connector

TURNTABLE MOTOR REMOVAL

1. Disconnect the power supply cord.
2. Remove the turntable motor cover by snipping of material in four corners.
3. Where the corners have been snipped off, bend corner areas flat. No sharp edge must be evident after removal of turntable motor cover.
4. Disconnect the wire leads from the turntable motor and

remove the two (2) screws holding the turntable motor.

5. Now, the turntable motor is free.
6. After replacement use the one (1) screw provided with the turntable motor assembly to fit turntable motor cover.

NOTE: The one (1) screw to fit the turntable motor cover should be XHPSD40P12K00, XHPSD40P10K00 or XHPSD40P08K000.

COOLING FAN MOTOR REMOVAL

REMOVAL

1. Disconnect the power supply cord and then remove outer case.
2. Open the door and block it open.
3. Discharge high voltage capacitor.
4. Disconnect the wire leads from the fan motor.

5. Remove the one (1) screw holding the capacitor holder to the oven cavity rear plate.
6. Remove the one (1) screw holding the fan duct to the oven cavity rear plate.
7. Release the tabs of the capacitor holder from fan duct.
8. Remove the fan duct from the oven.

9. Remove the fan blade from the fan motor shaft according to the following procedure.
10. Hold the edge of the rotor of the fan motor by using a pair of groove joint pliers.

CAUTION:

- * **Make sure that no metal pieces enter the gap between the rotor and the stator of the fan motor because the rotor is easily shaven by pliers and metal pieces may be produced.**
 - * **Do not touch the pliers to the coil of the fan motor because the coil may be cut or injured.**
 - * **Do not disfigure the bracket by touching with the pliers.**
11. Remove the fan blade from the shaft of the fan motor by pulling and rotating the fan blade with your hand.
 12. Now, the fan blade will be free.

CAUTION:

- * **Do not reuse the removed fan blade because the hole (for shaft) may be larger than normal.**
13. Remove the two (2) screws holding the fan motor to the fan duct.
 14. Now, the fan motor is free.

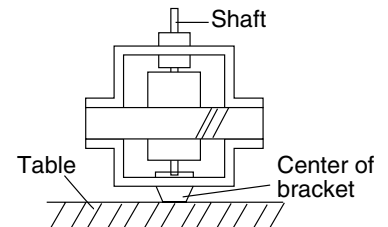
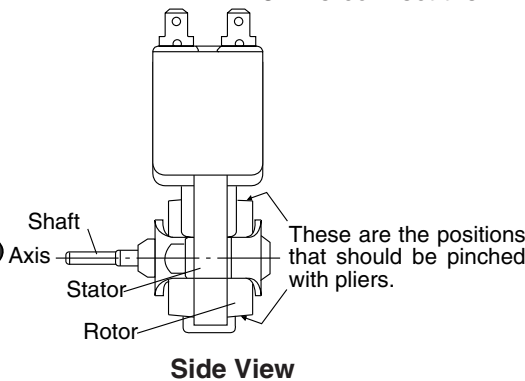
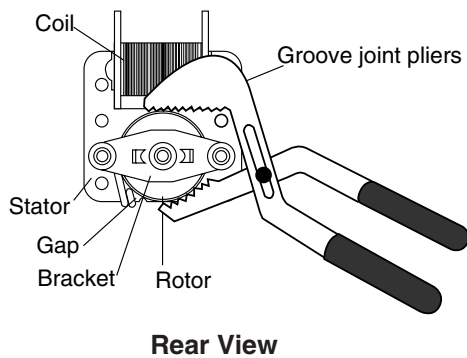
**INSTALLATION**

1. Install the fan motor to the fan duct with the two (2) screws.
2. Install the fan blade to the fan motor shaft according to the following procedure.
3. Hold the center of the bracket which supports the shaft of the fan motor on the flat table.
4. Install the fan blade to the shaft of fan motor by pushing the fan blade with a small, light weight, ball peen hammer or rubber mallet.

CAUTION:

- * **Do not hit the fan blade hard when installing because the bracket may be disfigured.**
 - * **Make sure that the fan blade rotates smooth after installation.**
 - * **Make sure that the axis of the shaft is not slanted.**
5. Install the fan duct to the oven cavity rear plate with the one (1) screw.
 6. Insert the tabs of the capacitor holder to the fan duct.
 7. Install the capacitor holder to the oven cavity rear plate with the one (1) screw.
 8. Re-connect the wire leads to the fan motor.

CONVECTION MOTOR REMOVAL

1. Disconnect the power supply cord and then remove outer case.
2. Open the door and block it open.
3. Discharge high voltage capacitor.
4. Now, the back plate with the sub back plate should be removed.
5. Disconnect the wire leads from the convection motor.
6. Remove the two (2) screws holding the conv. thermal cover to the oven cavity rear plate.
7. Remove the four (4) screws holding the convection duct to the oven cavity rear plate.
8. Remove the convection duct assembly from the oven cavity rear plate.
9. Remove the one (1) nut and the two (2) washers holding the convection fan to the convection motor shaft.
10. Remove the convection fan.
11. Remove the three (3) screws holding the convection duct to the conv. thermal cover.
12. Remove the convection duct with the conv. air angles from the conv. thermal cover.
13. Remove the thermal insulation.
14. Remove the one (1) pipe holding the cooling fan to the convection motor shaft.
15. Remove the cooling fan and the one (1) washer from the convection motor shaft.
16. Remove the two (2) screws holding the convection motor to the conv. thermal cover.
17. Remove the convection motor from the conv. thermal cover.
18. Remove the one (1) ring from the convection motor shaft.
19. Now, the convection motor is free.

THERMISTOR REMOVAL

1. Disconnect the power supply cord and then remove outer case.
2. Open the door and block it open.
3. Discharge high voltage capacitor.
4. Now, the back plate with the sub back plate should be removed.
5. Disconnect the connector CN-D from the control unit.
6. Remove the one (1) screw holding the air duct to the

- oven cavity rear plate.
- Remove the air duct with the air guide cover and the partition plate from the oven cavity rear plate.
 - Remove the one (1) screw holding the thermistor angle to the oven cavity rear plate.

- Remove the thermistor angle together with thermistor from the oven.
- Straighten the tab of the thermistor angle holding the thermistor to the thermistor angle.
- Remove the thermistor from the thermistor angle

POWER SUPPLY CORD REPLACEMENT

Removal

- Disconnect the power supply cord and then remove outer case.
- Open the door and block it open.
- Discharge high voltage capacitor.
- Remove the one (1) screw holding the green wire to the cavity rear plate.
- Disconnect the leads of the power supply cord from the main wire harness.
- Release the power supply cord from the oven cavity rear plate.
- Now, the power supply cord is free.

Re-install

- Insert the moulding cord stopper of power supply cord into the square hole of the oven cavity rear plate, referring to the Figure C-3.
- Install the earth wire lead of power supply cord to the

- cavity rear plate with one (1) screw and tighten the screw.
- Connect the brown and blue wire leads of power supply cord to the main wire harness correctly, referring to the Pictorial Diagram.

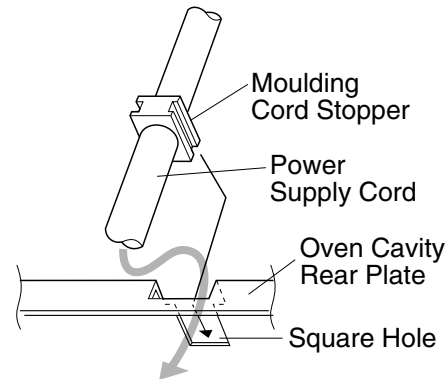

Figure C-3. Power Supply Cord Replacement

GRILL HEATER (TOP HEATER) REMOVAL

- Disconnect the power supply cord and then remove outer case.
- Open the door and block it open.
- Discharge high voltage capacitor.
- Remove the one (1) screw holding the exhaust duct to the oven cavity.
- Remove the exhaust duct from the oven cavity.
- Disconnect the wire leads from the grill heaters.
- Lay down the two (2) tabs holding the reflector to the

- oven cavity.
- Remove the reflector from the oven cavity by sliding it leftward.
- Remove the grill heaters and the short terminal together from the oven cavity top plate.
- Remove the two (2) screws holding the short terminal to the grill heaters.
- Now the individual grill heaters are free.

DOOR SENSING SWITCH/SECONDARY INTERLOCK SWITCH AND MONITOR SWITCH REMOVAL

- Disconnect the power supply cord and then remove outer case.
- Open the door and block it open.
- Discharge high voltage capacitor.
- Remove the control panel assembly referring to "CONTROL PANEL ASSEMBLY REMOVAL".
- Disconnect the leads from all switches.
- Remove the two (2) screws holding the latch hook to the oven cavity.
- Remove the latch hook.
- Push the retaining tab slightly and remove the switch.

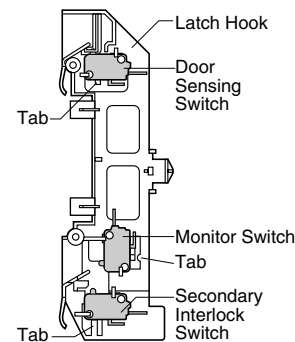

Figure C-4. Switches

DOOR SENSING SWITCH/SECONDARY INTERLOCK SWITCH AND MONITOR SWITCH ADJUSTMENT

- Disconnect the power supply cord and then remove outer case.
- Open the door and block it open.

- Discharge high voltage capacitor.
- If the door sensing switch, secondary interlock switch and monitor switch do not operate properly due to a

misadjustment, the following adjustment should be made.

4. Loosen the two (2) screws holding latch hook to the oven cavity front flange.
5. With door closed, adjust latch hook by moving it back and forth, and up and down. In and out play of the door allowed by the upper and lower position of the latch hook should be less than 0.5mm. The vertical position of the latch hook should be adjusted so that the door sensing switch and secondary interlock switch are activated with the door closed. The horizontal position of the latch hook should be adjusted so that the plunger of the monitor switch is pressed with the door closed.
6. Secure the screws with washers firmly.
7. Check the operation of all switches. If each switch has not activated with the door closed, loosen screw and adjust the latch hook position.

After adjustment, check the following.

1. In and out play of door remains less than 0.5mm when in the latched position. First check upper position of latch hook, pushing and pulling upper portion of door toward the oven face. Then check lower portion of the latch hook, pushing and pulling lower portion of the door toward the oven face. Both results (play in the door) should be less than 0.5mm.

2. The door sensing switch and secondary interlock switch interrupt the circuit before the door can be opened.
3. Monitor switch contacts close when door is opened.
4. Re-install outer case and check for microwave leakage around door with an approved microwave survey meter. (Refer to Microwave Measurement Procedure.)

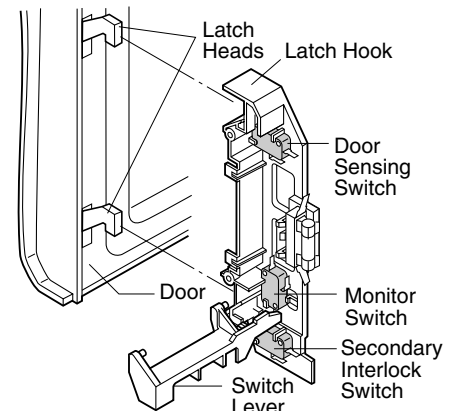

Figure C-5. Latch Switch Adjustments

DOOR REPLACEMENT

REMOVAL

1. Disconnect the power supply cord.
2. Push the open button and open the door slightly.
3. Insert a putty knife (thickness of about 0.5mm) into the gap between the choke cover and door frame as shown in Figure C-6 to free engaging parts.
4. Pry the principles of the lever and lift up the choke cover by inserting a putty knife as shown in Figure C-6.
5. Release choke cover from door panel.
6. Now choke cover is free.

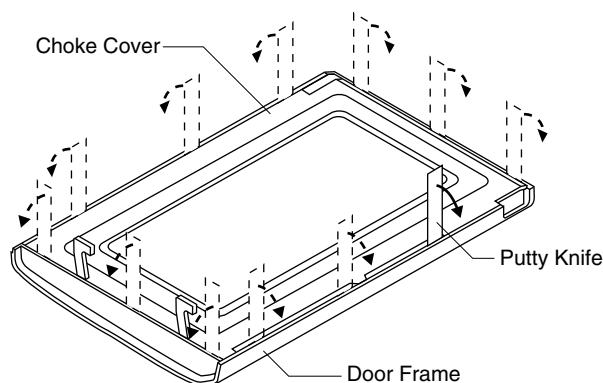

Figure C-6. Door Disassembly

7. Release two (2) pins of door panel from two (2) holes of upper and lower oven hinges by lifting up.
8. Now, door sub assembly is free from oven cavity.
9. Remove the four (4) screws holding the door panel to the door frame.
10. Release door panel from seven (7) tabs of door frame by sliding door panel downward.
11. Now, door panel is free.

12. Slide latch head upward and remove it from door frame with releasing latch spring from door frame and latch head.
13. Now, latch head and latch spring are free.
14. Remove the two (2) screws holding the glass stopper to the door frame.
15. Remove the glass stopper from the door frame.
16. Slide the front door glass left and then slide upwards to release the tabs holding it.
17. Now, the front door glass is free

RE-INSTALL

1. Re-install the front door glass to the door frame as follows.
 - 1-1. Insert the lower edge of the front door glass into the six (6) tabs of the door frame.
 - 1-2. Slide the front door glass upwards and insert the upper edge of the front door glass into the five (5) tabs of the door frame.
 - 1-3. Slide the front door glass right and insert the right edge of the front door glass into the two (2) tabs of the door frame.
2. Re-install the glass stopper to the door frame as follows.
 - 2-1. Re-install the glass stopper to the door frame so that the two (2) holes of the glass stopper meet the two (2) pins of the door frame.
 - 2-2. Hold the glass stopper to the door frame with the two (2) screws.
3. Re-install the latch spring to the latch head. Re-install the latch spring to the door frame. Re-install latch head to door frame.
4. Re-install door panel to door frame by fitting seven (7) tabs of door frame to seven (7) holes of door panel.

5. Hold the door panel to the door frame with four (4) screws.
6. Catch two (2) pins of door panel on two (2) hole of upper and lower oven hinges.
7. Re-install choke cover to door panel by pushing.

Note: After any service to the door;

- (A) **Make sure that door sensing switch and secondary interlock switch are operating properly. (Refer to chapter "Test Procedures".)**
- (B) **An approved microwave survey meter should be used to assure compliance with proper microwave radiation emission limitation standards. (Refer to Microwave Measurement Procedure.)**

After any service, make sure of the following :

1. Door latch heads smoothly catch latch hook through latch holes and that latch head goes through center of latch hole.
2. Deviation of door alignment from horizontal line of cavity face plate is to be less than 1.0mm.
3. Door is positioned with its face pressed toward cavity face plate.
4. Check for microwave leakage around door with an approved microwave survey meter. (Refer to Microwave Measurement Procedure.)

Note: The door on a microwave oven is designed to act as an electronic seal preventing the leakage of microwave energy from oven cavity during cook cycle. This function does not require that door be air-tight, moisture (condensation)-tight or light-tight. Therefore, occasional appearance of moisture, light or sensing of gentle warm air movement around oven door is not abnormal and do not in themselves indicate a leakage of microwave energy from oven cavity.

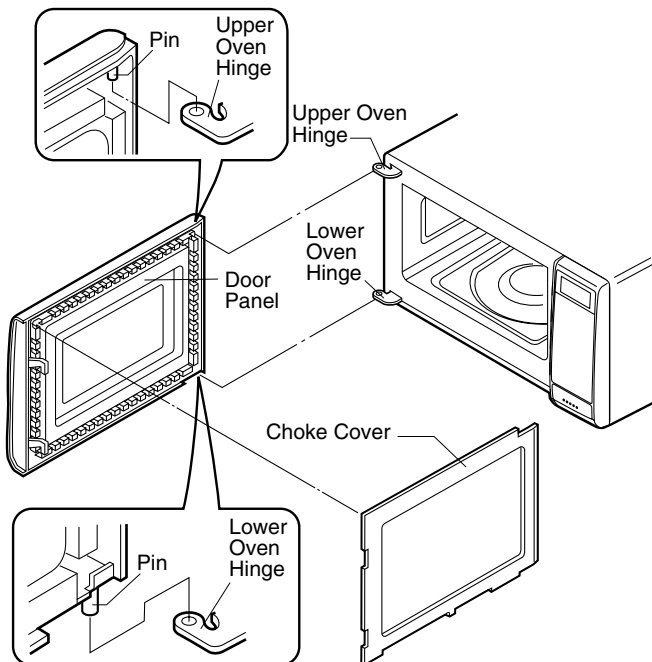
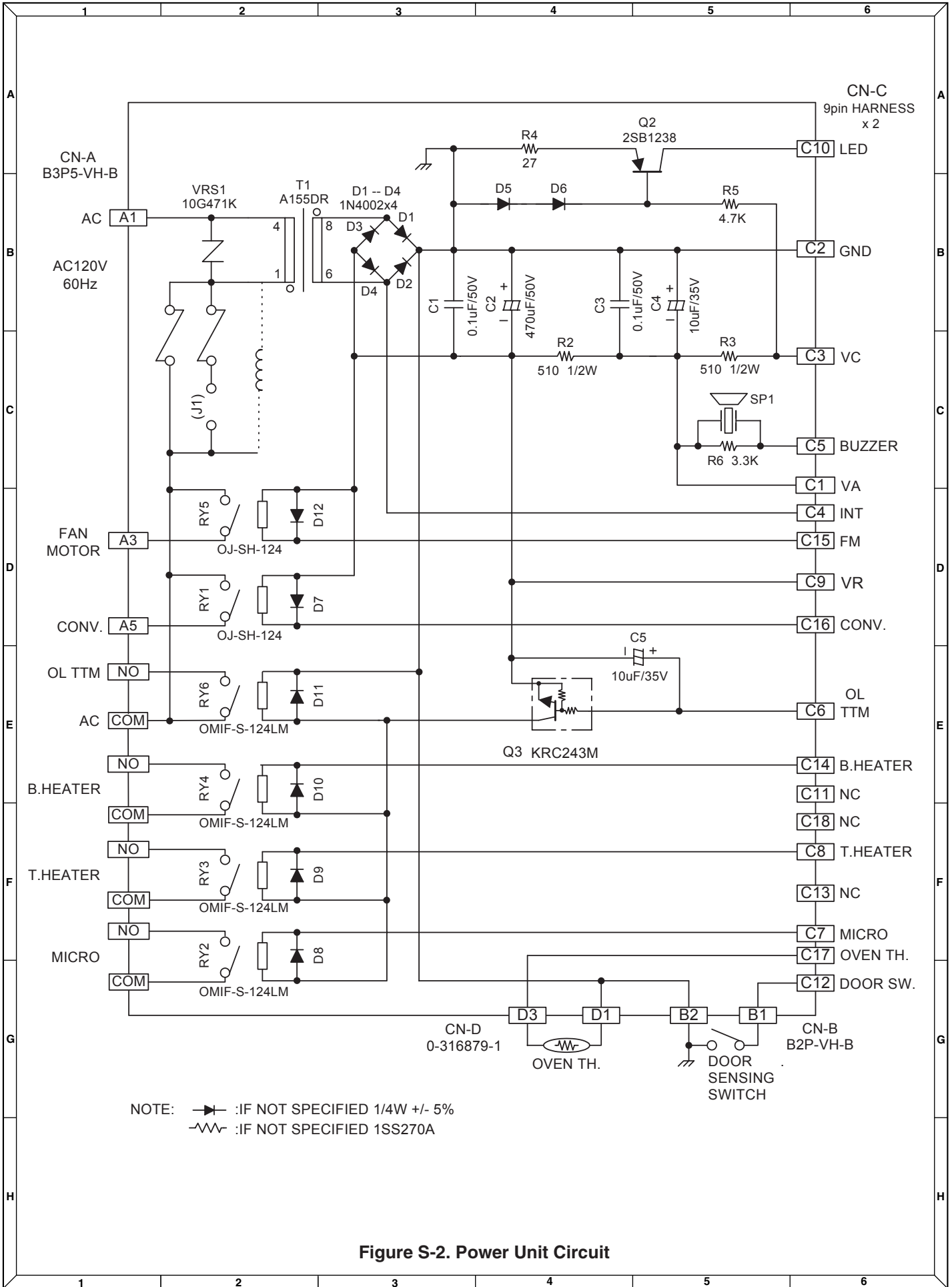

Figure C-7. Door Replacement



NOTE: \blacktriangleright :IF NOT SPECIFIED 1/4W +/- 5%
 $\sim\sim\sim$:IF NOT SPECIFIED 1SS270A

Figure S-2. Power Unit Circuit

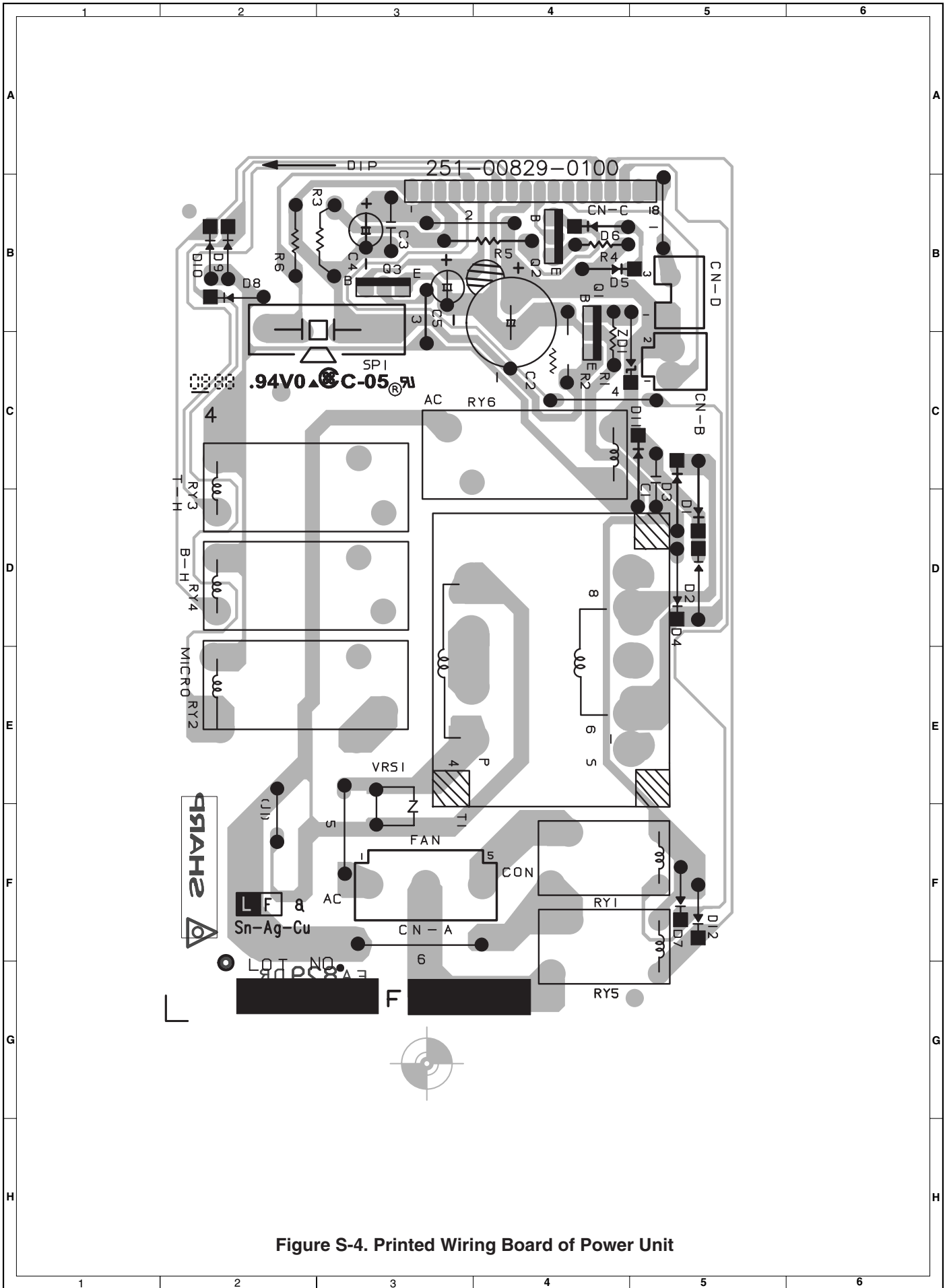

Figure S-4. Printed Wiring Board of Power Unit

PARTS LIST

**Note: The parts marked “Δ” may cause undue microwave exposure.
The parts marked “*” are used in voltage more than 250V.**

REF. NO.	PART NO.	DESCRIPTION	Q'TY	CODE
ELECTRIC PARTS				
1- 1	QSW-MA131WRE0	Secondary interlock switch / door sensing switch	2	AG
1- 1	QSW-MA110WRE0	Secondary interlock switch / door sensing switch (Interchangeable)	2	AH
1- 2	FFS-BA021WRK0	Monitor fuse and monitor switch (V-16G-2C25(R)) assembly	1	AL
1- 3	RMOTDA254WRZZ	Turntable motor	1	AV
1- 3	RMOTDA140WRE0	Turntable motor (Interchangeable)	1	AV
1- 3	RMOTDA188WRE0	Turntable motor (Interchangeable)	1	AS
* 1- 4	FH-DZA025WRK0	High voltage rectifier assembly	1	AN
* 1- 5	RC-QZA211WRE0	High voltage capacitor	1	AV
1- 6	RMOTEA370WRE0	Fan motor	1	AX
1- 7	QFSHDA009WRE0	Fuse holder	1	AG
1- 7	QFSHDA010WRE0	Fuse holder (Interchangeable)	1	AD
1- 8	FACCDAA074WRE0	Power supply cord	1	AW
1- 9	FH-HZA063WRE0	Thermistor	1	AP
1-10	RMOTEA372WRE0	Convection motor	1	AX
1-11	QTANNA017WRW0	Short terminal	1	AD
1-12	RHET-A223WRE0	Grill heater (Top heater)	2	AV
1-13	RHET-A209WRE0	Bottom heater	1	BA
1-14	RLMPTA030WRE0	Oven lamp	1	AE
1-15	QSOCLA021WRE0	Oven lamp socket	1	AG
1-16	RTHM-A109WRE0	Thermal cut-out 170 deg.	1	AM
1-16	RTHM-A048WRE0	Thermal cut-out 170 deg. (Interchangeable)	1	AH
1-17	RTHM-A078WRE0	Thermal cut-out 125 deg.	1	AK
* 1-18	RTRN-A568WRE0	Power transformer	1	BP
Δ* 1-19	RV-MZA222WRE0	Magnetron	1	BN
Δ* 1-19	RV-MZA267WRE0	Magnetron (Interchangeable)	1	BL
Δ* 1-19	RV-MZA197WRE0	Magnetron (Interchangeable)	1	BM

CABINET PARTS

2- 1	GCABDA097WRW0	Back plate	1	AW
2- 2	GCABUA869WRPZ	Outer case cabinet	1	BD
2- 3	GDAI-A305WRW0	Base plate	1	AX
2- 4	GLEGPA074WRE0	Leg	1	AC

CONTROL PANEL PARTS

3- 1	DPWBFC428WRUZ	Control unit	1	BK
3- 2	DPNLCB906WRKZ	Control panel frame with key unit	1	BB
3- 2-1	JBTN-B267WRTZ	Open button	1	AN
3- 2-2	MSPRCA050WRE0	Open button spring	1	AB
3- 2-3	FUNTKB151WREZ	Key unit	1	AX
3- 2-4	TCAUAA076WRR0	User caution label	1	AB
3- 3	XEPSD30P08XS0	Screw; 3mm x 8mm	4	AA

OVEN PARTS

Δ 4- 1	*****	Oven cavity (Not a replaceable part)	1	--
Δ 4- 2	PHOK-A136WRFZ	Latch hook	1	AK
4- 3	FDUC-A337WRK0	Air duct assembly	1	BH
4- 4	PCOVPA340WRW0	Sub back plate	1	AQ
4- 5	LANGQA478WRP0	Turntable motor angle	1	AP
4- 6	MSPRTA186WRE0	Plate spring	1	AE
4- 7	NCPL-A051WRE0	Turntable motor shaft	1	AN
4- 8	PSPA-A109WRE0	Spacer	1	AB
4- 9	LBNDKA136WRP0	HV capacitor holder	1	AQ
4-10	NFANJA041WRE0	Fan blade	1	AF
4-11	PDUC-A888WRFZ	Fan duct	1	AM
4-12	GCOVHA388WRW0	Bottom heater cover	1	AF
4-13	GLEGPA071WRF0	Leg	1	AG
4-14	LANGFA191WRW0	Chassis support	1	AN
4-15	LANGQA489WRP0	Thermistor angle	1	AW
4-16	LFLG-A030WREZ	Bearing	1	AM
4-17	MLEVPA226WRF0	Switch lever	1	AF
4-18	MSPR-A004WRE0	Heat seal spring	2	AF
4-19	PCOV-A011WRP0	Bottom heater angle	2	AM
4-20	PCOVPA339WRE0	Waveguide cover	1	AF
4-21	PCUSGA385WRP0	Cushion	1	AH
4-22	PCUSUA190WRP0	Cushion	1	AC
4-23	PCUSUA191WRP0	Cushion	1	AC
4-24	PDUC-A887WRFZ	Air intake duct	1	AG

REF. NO.	PART NO.	DESCRIPTION	Q'TY	CODE
4-25	PDUC-A692WRP0	Exhaust duct	1	AS
4-26	PDUC-A784WRWZ	Air guide	1	AP
4-27	PGLSPA518WRE0	Light glass	1	AZ
4-28	PPACGA090WRE0	Cushion	1	AG
4-29	PREFHA061WRW0	Reflector	1	BE
4-30	PSHEPA487WRE0	Heater film	1	AA
4-31	PSKR-A331WRP0	Air separate angle	1	AY
4-32	MSPRCA113WRE0	H-spring	2	AC
4-33	PCUSGA420WRP0	Cushion	1	AE
4-34	NFANMA047WRP0	Convection fan	1	AX
4-35	NFANMA048WRP0	Cooling fan	1	AX
4-36	PCUSUA499WRP0	Cushion	1	AC
4-37	PDUC-A707WRW0	Convection duct	1	AR
4-38	PFPF-A210WRE0	Thermal insulation	1	AM
4-39	PPIPFA030WRE0	Pipe	1	AK
4-40	PSKR-A339WRP0	Convection air angle	2	AX
4-41	PSKR-A345WRW0	Convection motor angle A	1	AU
4-42	PSKR-A346WRW0	Convection motor angle B	1	AR
4-43	PSLDHA140WRW0	Convection thermal cover	1	AQ
4-44	PCUSGA389WRP0	Cushion	1	AG

DOOR PARTS

△	5- 1	DDORFA857WRK0	Door panel assembly	1	BB
△	5- 2	GWAKPA948WRRZ	Door frame	1	AZ
△	5- 3	LSTPPA176WRF0	Latch head	1	AN
	5- 4	LSTPPA177WRF0	Glass stopper	1	AF
	5- 5	MSPRTA187WRE0	Latch spring	1	AC
	5- 6	PGLSPA513WRE0	Front door glass	1	AV
	5- 7	XCPD40P06000	Screw : 4mm x 6mm	2	AA
	5- 8	XCPD40P08000	Screw : 4mm x 8mm	6	AA
	5- 9	GCOVHA387WRF0	Choke cover	1	AS

MISCELLANEOUS

	6- 1	FAMI-A104WRM0	Rack	1	AQ
	6- 2	TCAUAA145WRR0	Earth caution	2	AG
	6- 3	FSRAHA063WRYZ	Turntable support	1	AK
	6- 4	NTNT-A092WRH0	Turntable	1	AZ
	6- 5	TCAUAA200WRR0	Monitor caution	1	AB
	6- 6	TINSEB053WRRZ	Instruction book	1	AM
	6- 7	FW-VZB045WRE0	Switch harness	1	AG
	6- 8	FW-VZB872WREZ	Main wire harness	1	BB
*	6- 9	QW-QZA213WRE0	High voltage wire B	1	AF
	6-10	LHLDWA011WRE0	Purse lock M	1	AB
	6-11	TCAUAA201WRR0	DHHS caution label	1	AC
	6-12	TCAUAA240WRR0	Screw caution	1	AC
	6-13	TLABMA978WRRZ	Menu label	1	AL
	6-14	TLABNB064WRRZ	Touch guide	1	AK

SCREWS,NUTS AND WASHERS

	7- 1	XHPSD40P08K00	Screw : 4mm x 8mm	13	AA
	7- 2	XEPSD40P25000	Screw : 4mm x 25mm	2	AA
	7- 3	LX-EZA042WRE0	Special screw	2	AB
	7- 4	LX-NZ0061WRE0	Flange nut	4	AA
	7- 5	XBPWW30P05K00	Screw : 3mm x 5mm	2	AA
	7- 6	XCTWW40P08000	Screw : 4mm x 8mm	8	AB
	7- 7	XHPSD30P06000	Screw : 3mm x 6mm	1	AA
	7- 8	XHTSD40P08RV0	Screw : 4mm x 8mm	3	AA
	7- 9	XOTSD40P12RV0	Screw : 4mm x 12mm	13	AA
	7-10	XOTSD40P12000	Screw : 4mm x 12mm	10	AA
	7-11	XCPD40P08000	Screw : 4mm x 8mm	1	AA
	7-12	XOTSE40P08000	Screw : 4mm x 8mm	1	AA
	7-13	XBTSD40P05000	Screw : 4mm x 5mm	2	AA
	7-14	XNEUW40-32000	Nut : 4mm x 3.2mm	1	AA
	7-15	XRESE40-06000	Ring : 4mm x 0.6mm	1	AA
	7-16	XWHUW40-08000	Washer : 4mm x 0.8mm	1	AA
	7-17	XWHUW48-08120	Washer : 4.8mm x 0.8mm	1	AA
	7-18	XWSUW40-10000	Washer : 4mm x 1.0mm	1	AA
	7-19	LX-CZA070WRE0	Special screw (Torx tamper proof screw)	2	AC

HOW TO ORDER REPLACEMENT PARTS

To have your order filled promptly and correctly, please furnish the following information.

1. MODEL NUMBER 2. REF. NO. 3. PART NO. 4. DESCRIPTION

Order Parts from the authorized SHARP parts Distributor for your area.

Defective parts requiring return should be returned as indicated in the Service Policy.

PACKING AND ACCESSORIES

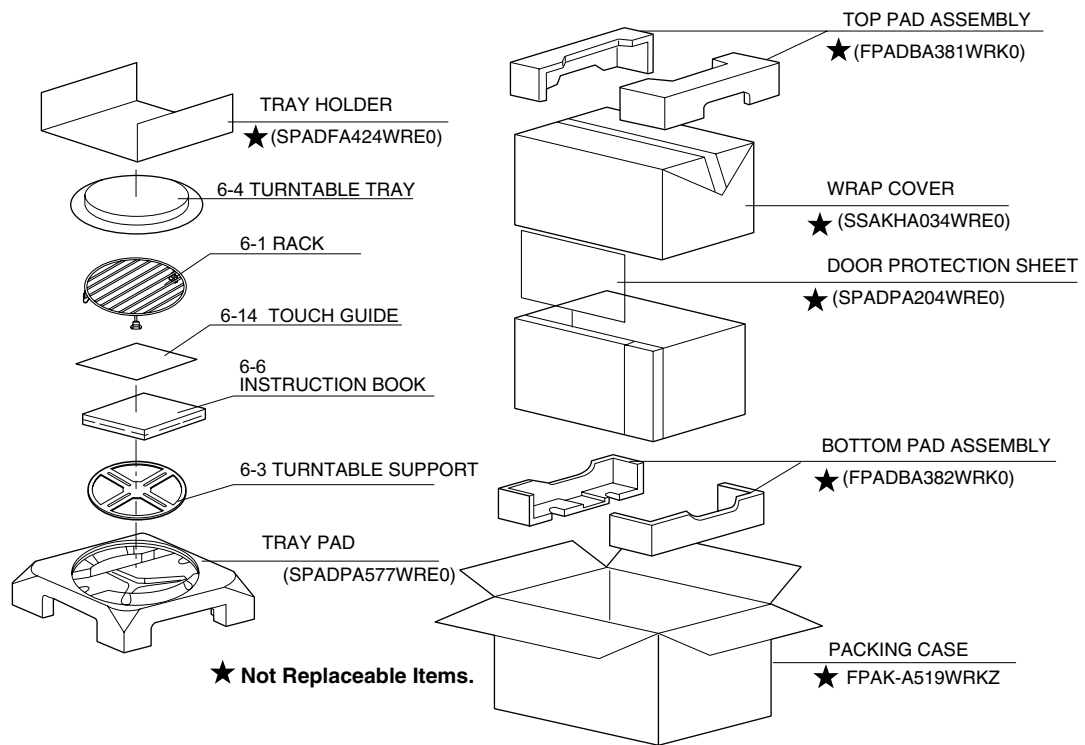

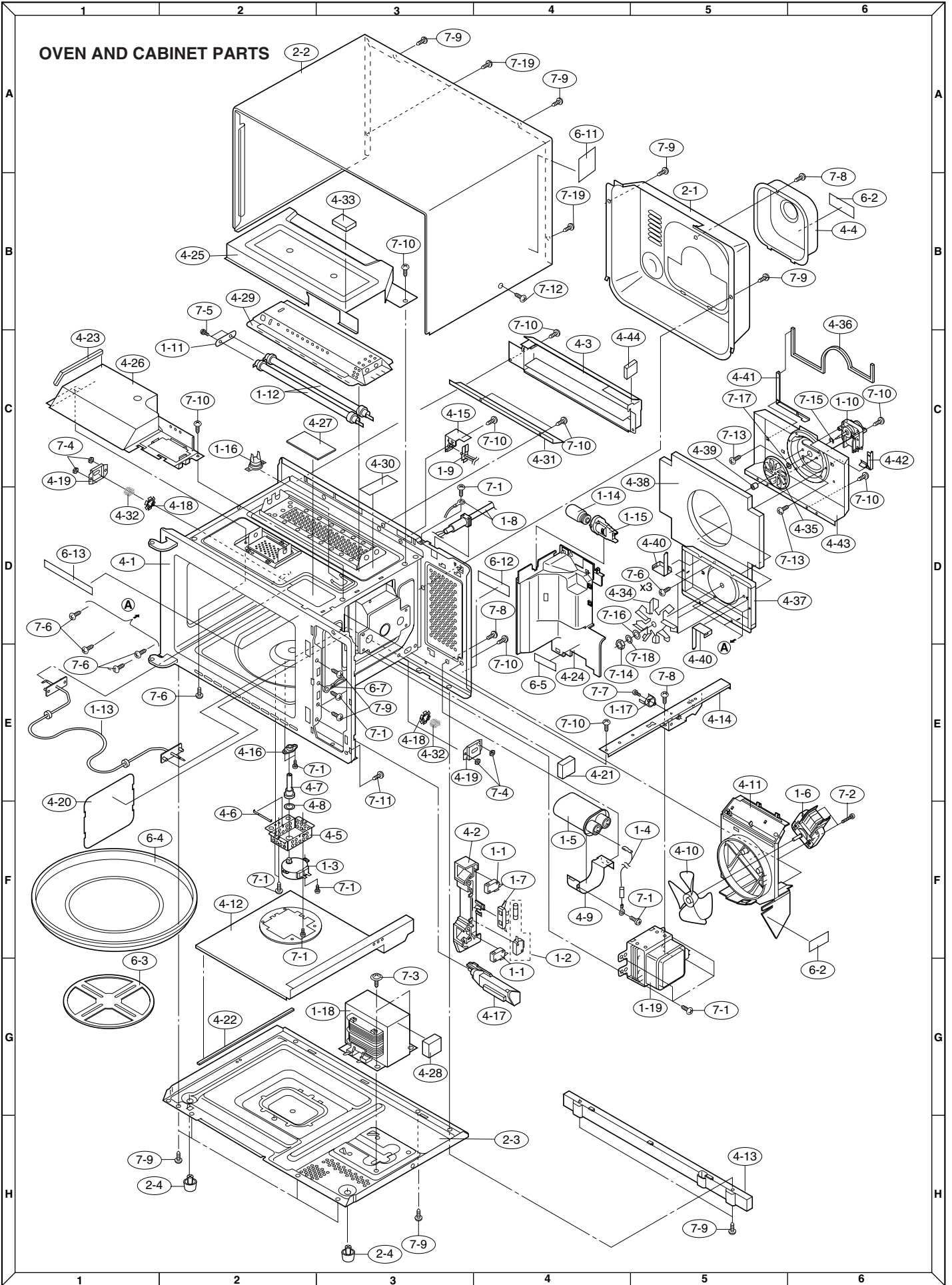

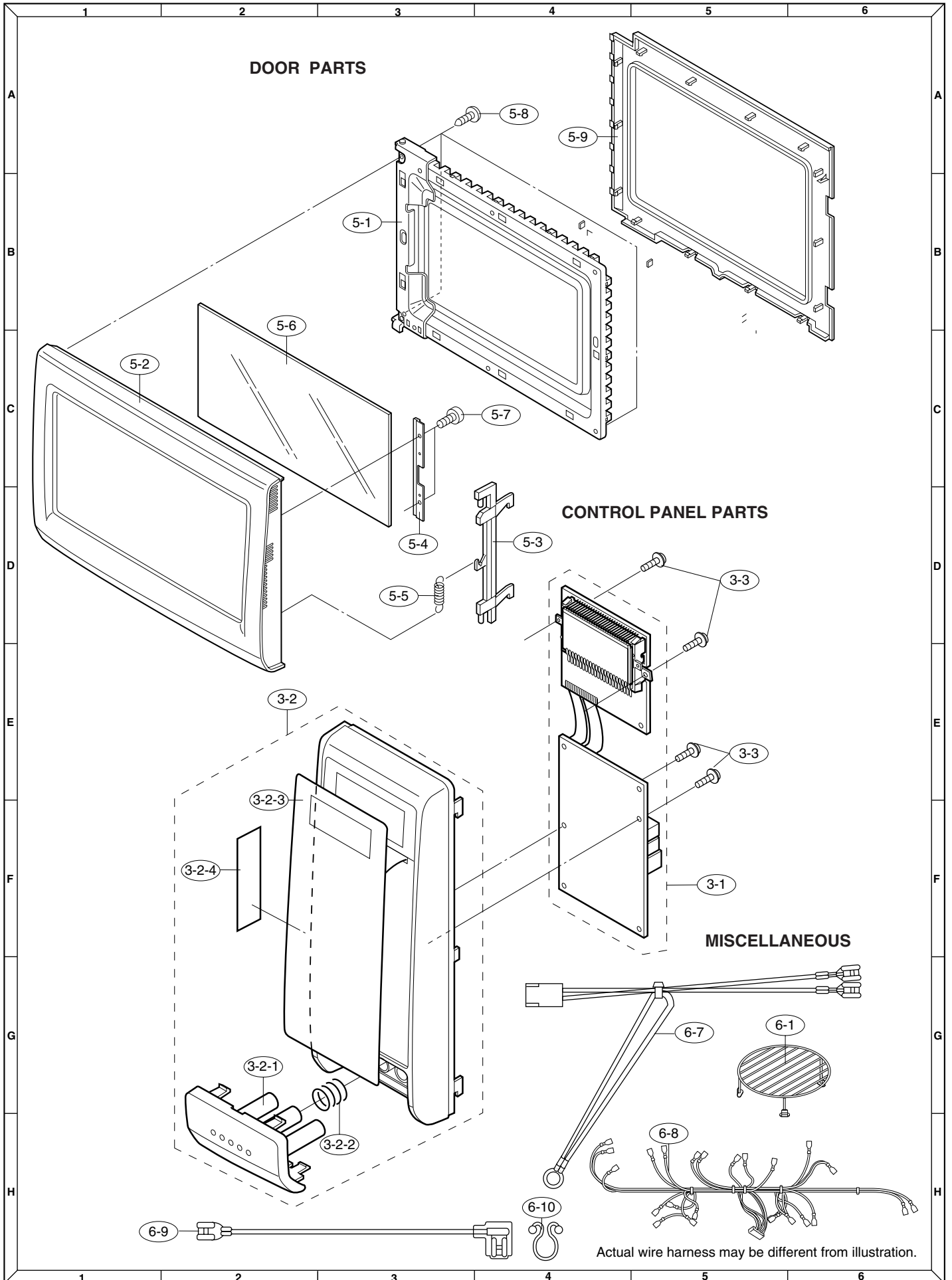

SHARP

COPYRIGHT © 2004 BY SHARP CORPORATION

ALL RIGHTS RESERVED.

No part of this publication may be reproduced, stored in retrieval systems, or transmitted in any form or by any means, electronic, mechanical, photocopying, recording, or otherwise, without prior written permission of the publisher.