



High Wattage Strip Warmer

Models: 423SWT18, 423SWT18CP, 423SWT24, 423SWT24CP, 423SWT30, 423SWT30CP, 423SWT36, 423SWT36CP, 423SWT42, 423SWT42CP, 423SWT48, 423SWT48CP, 423SWT54, 423SWT54CP, 423SWT60, 423SWT60CP, 423SWT72, 423SWT72CP, 423SWI18, 423SWI18CP, 423SWI24, 423SWI24CP, 423SWI30, 423SWI30CP, 423SWI36, 423SWI36CP, 423SWI42, 423SWI42CP, 423SWI48, 423SWI48CP, 423SWI54, 423SWI54CP, 423SWI60, 423SWI60CP, 423SWI72, 423SWI72CP, 423SWTD24, 423SWTD36, 423SWTD48, 423SWTD60, 423SWID24, 423SWID36, 423SWID48, 423SWID60

Please read and keep these instructions. Indoor use only.

09/2020

Table of Contents

Introduction	3
Requirements and Safety Instructions.....	3
Overview	4-5
Operation.....	6
Installation	6
Cleaning	6
Parts Diagram.....	7-8
Wiring Diagram.....	9
Limited Warranty.....	10

Introduction, Requirements and Safety

Introduction

1. Please read instructions before using this appliance. This appliance is for commercial use only.
2. When using electrical appliances, basic precautions should always be followed to reduce the risk of fire, electric shock and injury.
3. Clean machine thoroughly before and after each use following the cleaning instructions provided below.

Safety Instructions

WARNING!

All power must be disconnected at power source before any service procedure is performed.

1. This appliance is hot when in use. To avoid burns, do not let bare skin touch hot surfaces. Keep combustible materials, such as drapes and other furnishings, away from appliance.
2. Extreme caution is necessary when any appliance is used by or near children and whenever the appliance is left unattended.
3. Always unplug appliance when not in use and before cleaning, adjusting or maintaining this machine. To disconnect appliance, turn switch off and remove plug from power source.
4. Do not operate any appliance with a damaged cord or plug, after the appliance malfunctions, has been dropped or damaged. Return appliance to an authorized service facility for examination, electrical or mechanical adjustment or repair.
5. Do not use outdoors. This appliance is not intended for wet or moist locations. Never locate appliance where it may fall into water.
6. Connect to properly grounded outlets only. Avoid the use of extension cords. Do not run cord under carpeting, runners or the like. Arrange cord away from traffic area and where it will not create a tripping hazard.
7. This appliance is equipped with a power cord with a three blade plug. Plug **ONLY** into a matching three blade outlet. **DO NOT** cut or break off the third blade or attempt to use with a two blade extension cord.
8. To prevent a possible fire, it is recommended that the unit is placed on a non-combustible surface.
9. This appliance has electrical parts. Do not use it in areas where gasoline, paint, or flammable liquids are used or stored.

Overview

Toggle Hardwired

MODEL #	OVERALL DIMENSIONS	POWER SUPPLY	TYPE
423SWT18	18"L x 6.1"W x 2.6"H	120V, 350W	Single
423SWT24	24"L x 6.1"W x 2.6"H	120V, 500W	Single
423SWT30	30"L x 6.1"W x 2.6"H	120V, 650W	Single
423SWT36	36"L x 6.1"W x 2.6"H	120V, 850W	Single
423SWT42	42"L x 6.1"W x 2.6"H	120V, 1050W	Single
423SWT48	48"L x 6.1"W x 2.6"H	120V, 1200W	Single
423SWT54	54"L x 6.1"W x 2.6"H	120V, 1425W	Single
423SWT60	60"L x 6.1"W x 2.6"H	120V, 1550W	Single
423SWT72	72"L x 6.1"W x 2.6"H	120V, 1750W	Single
423SWTD24	24"L x 15.2"W x 2.6"H	120V, 1000W	Double
423SWTD36	36"L x 15.2"W x 2.6"H	120V, 1700W	Double
423SWTD48	48"L x 15.2"W x 2.6"H	120V, 1900W	Double
423SWTD60	60"L x 15.2"W x 2.6"H	120V, 2200W	Double

Infinite Hardwired

MODEL #	OVERALL DIMENSIONS	POWER SUPPLY	TYPE
423SWI18	18"L x 6.1"W x 2.6"H	120V, 350W	Single
423SWI24	24"L x 6.1"W x 2.6"H	120V, 500W	Single
423SWI30	30"L x 6.1"W x 2.6"H	120V, 650W	Single
423SWI36	36"L x 6.1"W x 2.6"H	120V, 850W	Single
423SWI42	42"L x 6.1"W x 2.6"H	120V, 1050W	Single
423SWI48	48"L x 6.1"W x 2.6"H	120V, 1200W	Single
423SWI54	54"L x 6.1"W x 2.6"H	120V, 1425W	Single
423SWI60	60"L x 6.1"W x 2.6"H	120V, 1550W	Single
423SWI72	72"L x 6.1"W x 2.6"H	120V, 1750W	Single
423SWID24	24"L x 15.2"W x 2.6"H	120V, 1000W	Double
423SWID36	36"L x 15.2"W x 2.6"H	120V, 1700W	Double
423SWID48	48"L x 15.2"W x 2.6"H	120V, 1900W	Double
423SWID60	60"L x 15.2"W x 2.6"H	120V, 2200W	Double

Toggle Cord & Plug

MODEL #	OVERALL DIMENSIONS	POWER SUPPLY	TYPE
423SWT18CP	18"L x 6.1"W x 2.6"H	120V, 350W	Single
423SWT24CP	24"L x 6.1"W x 2.6"H	120V, 500W	Single
423SWT30CP	30"L x 6.1"W x 2.6"H	120V, 650W	Single
423SWT36CP	36"L x 6.1"W x 2.6"H	120V, 850W	Single
423SWT42CP	42"L x 6.1"W x 2.6"H	120V, 1050W	Single
423SWT48CP	48"L x 6.1"W x 2.6"H	120V, 1200W	Single
423SWT54CP	54"L x 6.1"W x 2.6"H	120V, 1425W	Single
423SWT60CP	60"L x 6.1"W x 2.6"H	120V, 1550W	Single
423SWT72CP	72"L x 6.1"W x 2.6"H	120V, 1750W	Single

Infinite Cord & Plug

MODEL #	OVERALL DIMENSIONS	POWER SUPPLY	TYPE
423SWI18CP	18"L x 6.1"W x 2.6"H	120V, 350W	Single
423SWI24CP	24"L x 6.1"W x 2.6"H	120V, 500W	Single
423SWI30CP	30"L x 6.1"W x 2.6"H	120V, 650W	Single
423SWI36CP	36"L x 6.1"W x 2.6"H	120V, 850W	Single
423SWI42CP	42"L x 6.1"W x 2.6"H	120V, 1050W	Single
423SWI48CP	48"L x 6.1"W x 2.6"H	120V, 1200W	Single
423SWI54CP	54"L x 6.1"W x 2.6"H	120V, 1425W	Single
423SWI60CP	60"L x 6.1"W x 2.6"H	120V, 1550W	Single
423SWI72CP	72"L x 6.1"W x 2.6"H	120V, 1750W	Single

Operation

1. Plug cord into grounded electrical outlet of the correct voltage. Electrical shock can occur if appliance is not grounded.
2. Flip the switch to the 'On' position.
3. Place food products directly under the elements for best results.
4. Turn unit off when not in use.
5. To disconnect appliance, turn switches off and remove plug from power source.

Installation

1. For strip warmers of high wattage (18-25 watts per inch). 10-16" is the recommended mounting height
2. Do not install strip warmers above or around combustible surfaces.
3. Strip warmers can be mounted to the underside of a shelf with a minimum gap of 1" to protect electrical system.
4. Remove the two center screws from end plates. Align the holes on the bracket with the mounting holes on the end plate. Use the screw to secure the bracket.
5. Drill 4 holes on the underside of a shelf, use fasteners to install the brackets to the underside of the shelf.
6. A qualified electrician must install hardwired models or warranty will be void.

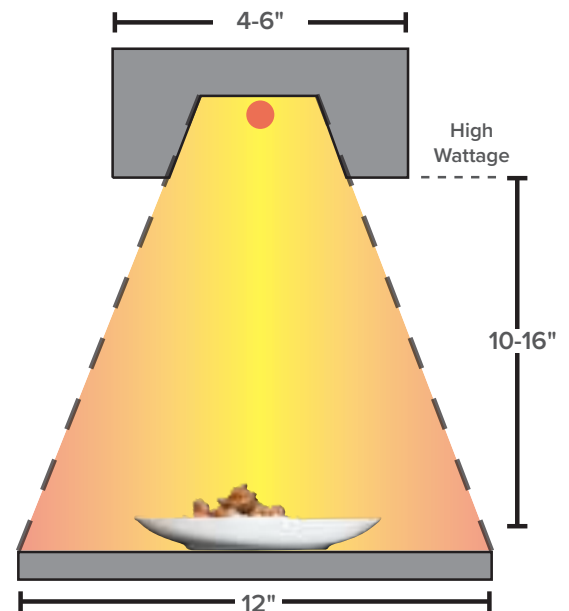

Cleaning

1. Unplug the cord and let warmer cool before cleaning or moving.
2. This unit can be cleaned with a damp sponge and mild soap. Rinse with clean water and wipe dry.
3. Do not immerse in water or other liquid.

Parts Diagram - Toggle Control

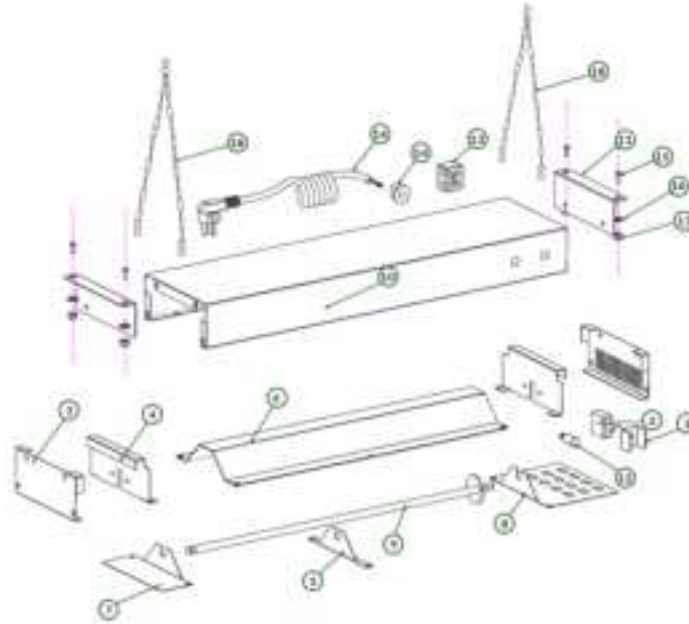

NO.	Description	Replacement Part#	Pcs.
1	Switch Guard	423PSW01 (423SWT18/24/30/36/42/48/54/60/72, 423SWT18/24/30/36/42/48/54/60/72CP, 423TD24/36/48/60)	1
2	Toggle Switch	423PSWSWITCH (423SWT18/24/30/36/42/48/54/60/72, 423SWT18/24/30/36/42/48/54/60/72 CP, 423TD24/36/48/60)	1
3	End Plates		2
4	Element Guard	423PSWGUARD (423SWI18/24/30/36/42/48/54/60/72, 423SWT18/24/30/36/42/48/54/60/72, 423SWT18/24/30/36/42/48/54/60/72CP, 423TD24/36/48/60)	1
5	Element Support (Mid)	423PSWELEM1 (423SWT18/24/30/36/42/48/54/60/72, 423SWT18/24/30/36/42/48/54/60/72 CP, 423TD24/36/48/60)	1
6	Reflector		1
7	Element Support (Left)	423PSWELEM2 (423SWT18/24/30/36/42/48/54/60/72, 423SWT18/24/30/36/42/48/54/60/72 CP, 423TD24/36/48/60)	1
8	Cover Plate		1
9	Element	423PSWELEM24 (423SWT24/T24CP/I24/I24CP/TD24), 423PSWELEM36 (423SWT36/T36CP/TD36), 423PSWELEM48 (423SWT48/T48CPTD48), 423PSWELEM60 (423SWT60/T60CPTD60), 423PSWELEM72 (423SWT72/T72CP/I72), 423PSWELEM18 (423SWT18/T18CP), 423PSWELEM30 (423SWT30/T30CP), 423PSWELEM42 (423SWT42/T42CP/I42), 423PSWELEM54 (423SWT54/T54CP)	1
10	Housing		1
11	Mounting Brackets	423PBRACKET (423SWT18/24/30/36/42/48/54/60/72, 423SWT18/24/30/36/42/48/54/60/72 CP, 423TD24/36/48/60)	2

Toggle Control, cont.

NO.	Description	Replacement Part#	Pcs.
12	Indicator Light		1
13	Terminal Block	423PSWTB (423SWT18/24/30/36/42/48/54/60/72, 423SWT18/24/30/36/42/48/54/60/72CP, 423TD24/36/48/60)	1
14	Cord and Plug Set	423PSWCORD15 (423SWT18/24/30/36/42/48/54/60/72, 423SWT18/24/30/36/42/48/54/60/72 CP, 423TD24/36/48/60)	1
15	Screw		1
16	Washer		1
17	Nut		1
18	Support Chains	423PSWCHAIN (423SWT18/24/30/36/42/48/54/60/72, 423SWT18/24/30/36/42/48/54/60/72 CP, 423TD24/36/48/60)	2

Parts Diagram - Infinite Control

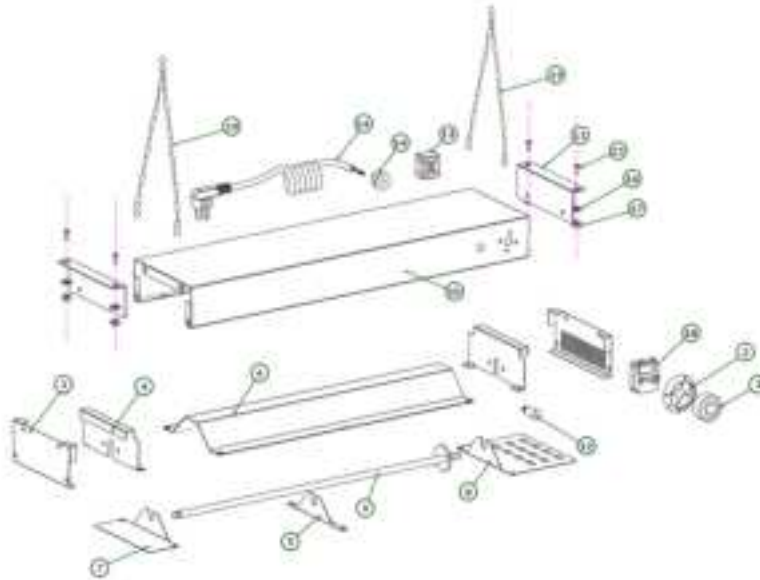

NO.	Description	Replacement Part#	Pcs.
1	Knob	423PSWKNOB (423SW18/24/30/36/42/48/54/60/72, 423SW18/24/30/36/42/48/54/60/72CP, 423ID24/36/48/60)	1
2	Knob Base		1
3	End Plates		2
4	Element Guard	423PSWGUARD (423SW18/24/30/36/42/48/54/60/72, 423SW18/24/30/36/42/48/54/60/72 CP, 423ID24/36/48/60)	1
5	Element Support (Mid)	423PSWELEM1 (423SW18/24/30/36/42/48/54/60/72, 423SW18/24/30/36/42/48/54/60/72 CP, 423ID24/36/48/60)	1
6	Reflector		1

NO.	Description	Replacement Part#	Pcs.
7	Element Support (Left)	423PSWELEM2 (423SW118/24/30/36/42/48/54/60/72, 423SW118/24/30/36/42/48/54/60/72 CP, 423ID24/36/48/60)	1
8	Cover Plate		1
9	Element	423PSWELEM24 (I24/I24CP/ID24), 423PSWELEM36 (I36/I36CP/ID36), 423PSWELEM48 (I48/I48CP/ID48), 423PSWELEM60 (I60/I60CP/ID60), 423PSWELEM72 (I72/I72CP)	1
10	Housing		1
11	Mounting Brackets	423PBRACKET (423SW118/24/30/36/42/48/54/60/72, 423SW118/24/30/36/42/48/54/60/72CP, 423ID24/36/48/60)	2
12	Indicator Light		1
13	Terminal Block	423PSWTB (423SW118/24/30/36/42/48/54/60/72, 423SW118/24/30/36/42/48/54/60/72CP, 423ID24/36/48/60)	1
14	Cord and Plug Set	423PSWCORD15 (423SW118/24/30/36/42/48/54/60/72, 423SW118/24/30/36/42/48/54/60/72 CP, 423ID24/36/48/60)	1
15	Screw		1
16	Washer		1
17	Nut		1
18	Infinite Heat Control	423PSWTERM (423SW118/24/30/36/42/48/54/60/72, 423SW118/24/30/36/42/48/54/60/72 CP, 423ID24/36/48/60)	1
19	Support Chains	423PSWCHAIN (423SW118/24/30/36/42/48/54/60/72, 423SW118/24/30/36/42/48/54/60/72 CP, 423ID24/36/48/60)	2

Wiring Diagram - Toggle Control

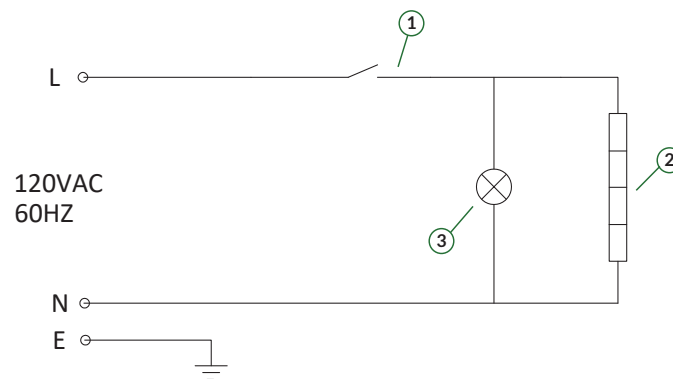

NO.	Description
1	Switch
2	Heater
3	Indicator

Wiring Diagram - Infinite Control

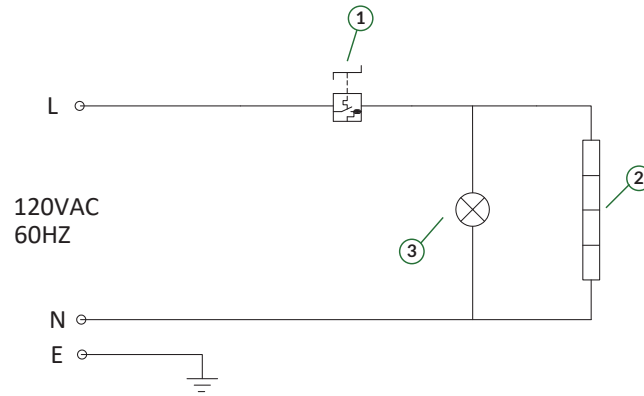

NO.	Description
1	Energy Regulator
2	Heater
3	Indicator

Strip Warmer 2 Year No Hassle Replacement Warranty

Servit Strip Warmers are backed by an industry-leading 2 year “no hassle” replacement warranty. When you buy a Servit Strip Warmer, you are entrusting it with the quality and safety of your food, which is ultimately your customers' experience. If it goes down, you can be sure that Servit will quickly and easily make replacing it a breeze, getting a new unit out to you in as little as 24 hours. Don't wait for a service technician to come out and fix it, simply swap out and get back to business.

This is the sole and exclusive warranty made by Servit covering your Servit branded strip warmers. A claim under this warranty must be made within 2 years from the date of purchase of the equipment. Only the equipment's original purchaser may make a claim under this warranty. Servit reserves the right to approve or deny any replacement request. The warranty is not transferable. Servit Equipment installed in/on a food truck or trailer will be limited to a period of 30 days from the original date of purchase. This warranty only covers Servit Strip Warmers and does not cover other products or product lines under the Servit brand.

To Make a Warranty Claim:

For Warranty Inquiries contact the location where you purchased the product:

- WebstaurantStore.com: Contact help@webstaurantstore.com. Please have your order number ready.
- The Restaurant Store: If you purchased this unit from your local store, please contact your store directly.
- TheRestaurantStore.com: Online purchases, call 717-392-7261. Please have your order number ready.

Failure to contact the designated location prior to obtaining equipment service may void your warranty.

Servit makes no other warranties, express or implied, statutory or otherwise, and HEREBY DISCLAIMS ALL IMPLIED WARRANTIES, INCLUDING THE IMPLIED WARRANTIES OF MERCHANTABILITY AND OF FITNESS FOR A PARTICULAR PURPOSE.

This Limited Warranty does not cover:

- Equipment sold or used outside the Continental United States
- Use of unfiltered water (if applicable)
- Servit has the sole discretion on wearable parts not covered under warranty
- Equipment not purchased directly from an authorized dealer
- Equipment used for residential or other non-commercial purposes
- Equipment that has been altered, modified, or repaired by anyone other than an authorized service agency
- Equipment where the serial number plate has been removed or altered.
- Damage or failure due to improper installation, improper utility connection or supply, and issues resulting from improper ventilation or airflow.
- Defects and damage due to improper maintenance, wear and tear, misuse, abuse, vandalism, or Act of God.

Any action for breach of this warranty must be commenced within 2 years of the date on which the breach occurred. No modification of this warranty, or waiver of its terms, shall be effective unless approved in a writing signed by the parties. The laws of the Commonwealth of Pennsylvania shall govern this warranty and the parties' rights and duties under it. Servit shall not under any circumstances be liable for incidental or consequential damages of any kind, including but not limited to loss of profits.