

HH Scott Tuners: Evaluation, Troubleshooting, Service, and Alignment

Written by Daev Roehr - daev@farmedia.com

Contributors:

Charles McRobert

Lee Schuster

Copyright © Daev Roehr, 2005-@006

This document may be distributed provided it is kept in its entirety. The information contained herein may be used and quoted for personal use.

All other rights reserved.



(Vintage drawings from the LT-10 tuner assembly manual.)

This document is a “work in progress”.

1. Any notes you see that look like <<>> are author notes for missing content.
2. If you see any factual or process errors, please send me an E-mail so I can address it in the next version.

Revision history

Date	Comment
7/26/2004	Creation: stream of consciousness writing, need to fix 1st person!
1/10/2005	First rough draft PDF gen'd
/10/2005	Prepared version .25 for first round of reviews
4/10/2005	Version .50 created for review
5/26/2005	Version .60 minor edits and comments from Scott group folded in.
12/28/2005	Version 0.75 minor edits and cleanup
4/15/2006	Version 0.90

Other Credits:

Major web sources of info were:

- Assorted E-mail posts from the list server @ hhscott@hhscott.com
- Lee K Shuster and the HH Scott website @ www.hhscott.com
- John Byrns and his website @ <http://users.rcn.com/jbyrns/ScottTuners.html>

Much of the historical content is lifted from any sources I could find, including E-mails, websites, and original company documentation. The sections on alignment are based on the authors experiences with vintage equipment and more modern test equipment.

CHAPTER 1Assumptions and tools 5

Scope of H.H. Scott tuner document 6
Disclaimers 7
Knowledge base 8
Skill set 8
Important safety tips 8
Required tools for any tuner work..... 9
Highly recommended tools 10
Tools instrument alignment and debugging..... 11
Modern vs. classic equipment considerations 12
Schematic changes, tolerances, voltages 12
Miscellaneous tips 13

CHAPTER 2Scott FM Tuners: History and Theory 15

Scott tuner History 16
Block diagram and basic theory 18
A FM tuner in brief: 18
Scott specific FM Tuner Basic Theory 19
Front End: RF/Local Oscillator/Mixer..... 19
Intermediate Frequency Stage, or IF 19
Limiter and AGC 20
Metering..... 21
Ratio detector 22
Scott FM Tuner theory and history - wrap up comments..... 24

CHAPTER 3Tuner Evaluation and troubleshooting 25

Tuner Evaluation 26
Pre flight checks, or what to do before you plug it in! 26
Safe power up process (Smoke is bad!)..... 26
FM Tuner Listening and Subjective Evaluation 27
AM Tuner Listening and Subjective Evaluation 28
Tuner Troubleshooting section 29
No power (no lights and no filaments glowing) 29
No sound 29
Hum in audio 29
Distorted sound 29
Poor sensitivity 29
Poor meter action, sound OK 29
Mono vs. Stereo - no stereo or distorted sound 29

CHAPTER 4 Scott FM Tuner Alignment Process 31

About Aligning a Scott FM Tuner.....	32
FM alignment - No instrument alignment techniques	33
FM alignment - Instruments	37
Instruments required.....	37
Instrument Limitations	37
Sweep alignment vs max amplitude techniques.....	39
Aligning the tuner.....	40
IF strip.....	40
Ratio detector	46
R.F. or Front End.....	47
FM tuner mods and performance improvements.....	49
Attaching 75 Ohm coaxial cabling	49
Reducing hum	50
Improving the sound	50
Changing the de-emphasis network for europe.....	50

CHAPTER 5 Scott FM Stereo Multiplex decoder 51

Scott Stereo History.....	52
(or so why isn't my stereo tuner... stereo?)	52
FM Stereo Multiplex - Generation 1.....	53
Stereo Guide - Generation 2	54
Sonic Monitor - Generation 3.....	55
Auto Sensor Stereo Switching, relays - Generation 4	55
Auto Sensor Stereo Switching, all electronic Generation 5	56
FM Multiplex Overview	57
Multiplex Decoder Design criteria	57
Evaluation	58
Discussion	58
Tools required.....	58
Aligning the MPX unit	58
Improving the sound	59

CHAPTER 6 Scott AM Tuners 61

A brief history of Scott AM tube tuners	62
Basic theory and block diagram	62
Process Discussion	62
Tools required.....	62
Limitations	63
Tools required.....	63
Aligning RF and IF stages	63
AM tuner mods and performance improvements	63

CHAPTER 1

*Assumptions and
tools*

This chapter contains:<<TBD list of major topics>>

Scope of H.H. Scott tuner document

The H.H. Scott tuner document covers history, basic theory, and evaluation & alignment of HH Scott tube based FM, AM, AM/FM Simulcast Stereomaster, and FM multiplex stereo tuners manufactured from approximately 1954 to 1967.

Although specific to Scott tube tuners, the evaluation and alignment processes are generally applicable to other vintage tuners, as well as the later solid state Scott tuners.

Disclaimers

- This document and all information contained within assumes experience with electronics circuitry in general and hazardous voltages in specific. The authors assumes no responsibilities or liabilities for anyone using the following information, its fitness or correctness for your particular usage. The author likewise assumes no responsibilities for election results, forces of nature, acts of god, or whimsical fairies.
- Mucking about with your tuner can just as easily deteriorate it's performance as increase it, especially if you do not have access to laboratory grade alignment equipment. I won't be held responsible if you can only receive AM talk radio stations or rap music after following these instructions.
- Bad or weak tubes will negate any alignment improvements you can do, and even lead you off into the weeds. At a minimum, test the tubes on a decent gM tester first!
- Although the information presented here is believed to be reasonably accurate and has been reviewed by some really smart people, no liability will be assumed for any microscopic, subtle, or even glaringly obvious and boneheaded errors in this document.
- Agian, vacuum tube based devices present and use lethal voltages, and can store these voltages for days. Proceed at your own risk!

Knowledge base

- This document assumes basic electronics knowledge, i.e, you can read a schematic and can identify these typical electronic parts: Tubes, resistors, diodes, RF transformers, power transformers, output transformers, polarized and non polarized capacitors, coils, chokes, “pots” (potentiometers or variable resistors), switches, both rotary and slide.

Skill set

- Basic electronics skills, such as soldering and basic hand tool usage abilities.
- The ability to work around lethal high voltages safely.
- Basic familiarity with ohms law and the ability to read the resistor color code.
- For the instrument alignment section, familiarity with basic tech bench procedures, like measuring voltages and using a scope and a signal generator.

Important safety tips

Now-common wiring safety practices (like heat shrink tubing on exposed high voltage or AC line terminals) were not used when these units were made.

- Follow the old tech rule when working on a plugged in unit: “One hand for the work, one hand for the pocket”. In other words, do not rest one hand on the chassis while playing with high voltages. If the other hand contacts the high voltage, your body (and more importantly your heart) will be part of the circuit, and these units have currents that are right in the range that stops hearts. Beeeeep, you’re history! The “body as a conductor warning” includes standing barefoot on concrete, taking a bath, smooching your sweetie, etc.
- When the bottom cover is off, AC line voltage will be also exposed. Not only are AC line voltages lethal, there is a lot more current available. This can cause serious burns, fires, explosions, and other exciting mayhem. Again, caution is required.
- Many units must be aligned while “on edge” in order to reach all of the adjustments. Secure the unit so that an accidental yank on a test lead, or a bump from an elbow, or a rub from a friendly cat(!) won’t send the unit crashing over.
<<Insert a picture of a secured tuner here.>>
- Tubes are hot! So are power resistors. If your clever enough to avoid getting electrocuted while working on you tuner, you can still always get burned!
- **Again... proceed at your own risk!**

Required tools for any tuner work

- The patience of several saints and lots of time
- A well lit workspace with a non conductive top surface
- A Variac plugged into a Ground Fault Interrupter (GFI)
- A high impedance AC/DC ohm meter, either a restored and calibrated vintage VTVM or a modern DVM, good to 600 volts
- An amplifier and speakers to use for "listening tests"
- Various hand tools: Screwdrivers, long nose, diagonal cutters
- Soldering tools: Soldering iron for electronics work of appx. 30-70 watts, rosin core solder (no acid!)

<<Insert picture of test bench with call-outs to individual test equipment & sample model numbers>>

One of the most important tools you will need is a set of alignment tools, also called "diddle-sticks" (No rude comments from the peanut gallery,+ please.) These are special non

metallic adjustment tools made for this sort of work. You can not use ferrous tools, the metal will throw off the alignments! My set looks like this:



Now, you may think this large set has everything you could possibly need, and more. Annoyingly (and oddly!), that is not the case. To prevent stripping out the slugs in the old Scott IF cans, you must make a special version of the flat blade adjuster, as the stock one is much too thin!

The standard flat blade adjuster is pictured on the left, and my custom one is on the right. Observe the custom one is much thicker than the stock one. I made it by clipping off one end of the stock flat blade adjuster and carefully grinding it down with a Dremmel tool until it snugly fit the Scotts IF can tuning slug. It's about 1/8" thick between the flats, and is much less likely to strip the can slugs than the stock one. It is highly recommended you make one of these, as the Scott transformer slugs are rather distressingly easy to damage otherwise.



Highly recommended tools

- A tube tester that measures gM
- A working Scott tuner to validate tubes with

Tools instrument alignment and debugging

- 100 MHz scope or better
- AM/FM/MPX signal generator
- Distortion analyzer

Modern vs. classic equipment considerations

VOM vs. VTVM vs. DMM

Multi-meters come in three basic types:

- The Classic Volt Ohm Meter, or VOM
- The Classic Vacuum Tube Voltmeter or VTVM
- And the modern Digital Multi-Meter, or DMM.

Any of these may be used in most cases, although this document will assume a DMM for these reasons:

- 1) In some cases it will be required to use a VTVM or DMM, as the VOM will load down (i.e. affect) sensitive high impedance circuits.
- 2) VTVM's are vintage equipment, and will require previous maintenance and calibration for proper results.

So, back to the DMM. You need to know some things about your DMM for correct results. First, double check that your DMM is rated to at least 600 volts. A lot of the current models are for lower voltages only.

Second, see how your DMM reads AC voltages. Typically this will be "averaging"; better meters will read "True RMS". In many cases the information is academic since the results via either method on a symmetric, continuous, 60-120 Hz signals will be very similar. But it can matter on complex wave shapes. Once you know the AVG AC volts, you can also figure peak to peak volts, crucial when one is dealing with rectifier and DC filter circuits. The simplified average formula is $AVG\ Volts = (PP\ Volts * .707)$, so $PP\ Volts = (AVG\ Volts * 1.414)$

Third, just because it's digital doesn't mean it's more accurate! Check your meter for accuracy and know its ratings.

Hz vs. Cycles

Frequency used to be specified in Cycles per Second or C.P.S. The name was changed in 19[65?] to honor Heinrich Hertz, the person who proved Maxwells equations on electromagnetic radiation were, in fact, correct. Hertz's research paved the way for the development of radio, television, and radar. All very cool, but cycles made more sense.

Generational accuracy issues

Another issue to be on the lookout for is equipment accuracy. The usual rule of thumb for test gear is to have a generation "better" than the unit under test. For example, Scott stereo decoders were pretty good for the time, so much so that the standard test equipment of the time couldn't keep up! For example, the commonly available and affordable vintage Heathkit IG-112 stereo signal generator doesn't have enough separation to align the multiplex for best operation.

Schematic changes, tolerances, voltages

Schematic changes

It is common to find that the Scott schematics vary somewhat from the actual production units. Don't panic! Scott products underwent constant improvements, and parts availability issues also contributed to the general mayhem. Understanding the basic schematic building blocks "Block diagram and basic theory" on page 18 can help understand differences between Scott models and changes. When in doubt, ask on the Scott forum for advice, there are many years of experience there.

AC line voltages

AC line voltages in the US are a bit variable, anywhere from about 110 to about 125 VAC. Since most of the Scott circuits assume a nominal 117 VAC with a 10% variation, you should be fine in that range. When looking at voltages on schematics, it's easiest to track your particular units health if you adjust your variac to the voltage specified on the schematic for the measurements. That way, you can come back later and have an exact comparison.

Schematic Voltage tolerances

The tolerances for the AC and DC voltages should be specified on the schematic. If not, they typically have a tolerance of +/- 10%, so don't get too carried away over fractional variations. This is all too common with folks with DMM's, that extra accuracy doesn't really matter for the most part.

Miscellaneous tips

Refurbishing tube sockets

The idea is tube pins and sockets should make a good solid connection, and after 40 years they often don't.

I follow a 3 step process for tube connection cleanup.

1. Clean the tube pins of oxidation. I use ink pen erasers, 0000 steel wool, emery boards, and/or wire brushes, depending on the corrosion and whether the pins were plated or not.
2. Clean the sockets. For larger sockets, I run a pipe cleaner through them, sprayed with a bit of D5. Smaller sockets I just directly spray with D5. In both cases, I plug/unplug the tube a few times to work the D5 into the connection.
3. Finally, I use a dental or solder pick to compress the socket connection by inserting the tool between the socket wall and the outer edge of the metal connector pin. This is commonly called re-tensioning, which refers to the spring effect of the pins "grab" being restored.

Cleaning the chassis

<<Note about fragile lettering and grime removal from the RF front end.>>

Adjusting transformers

These transformers use a powdered ferrous material compressed into threaded "slugs". This slug is extremely brittle and easy to damage, and once damaged, may not adjust any further, or worse, will prevent proper alignment. Most of the transformers have a pair of these slugs, one on top and one on bottom.

Here's a few tips to to avoid damage.

First, make sure to use the proper type and size adjustment tool to avoid damaging the adjustment slot. Most of the IF's are a flat type, the detector is a hex type.

Second, do not force the slug past it's maximum travel or grind it into the other slug.

Third, these units are fifty years old and can be a little creaky. In some cases, the slugs may be frozen in place. Do not spray cleaners or lubricants into them, that will change their RF characteristics for the worse. Instead, a spot of talcum powder can be used, the technique used at the factory.

CHAPTER 2

*Scott FM Tuners:
History and Theory*

This chapter contains:<<TBD list of major topics>>

Scott tuner History

The first Scott FM tuners were mono tube units for the broadcast trade. These were built after World War II when the American 88-108 MHz FM frequency band was established. Scott's first FM tuner was the 310(A). Made in 1954, it sold for \$170 USD, a princely sum in those days. Improvements were introduced in the B version (including the famous "Silver plated front end" for stability and noise rejection) in 1957.

Scott tube tuners were broadly separated into two categories: Broadcast monitors and Consumer tuners. The Broadcast monitor series was the 310/4310 models and the consumer tuners were the 311 series, essentially cost downs of the 310's. The 311 series used the same front end as the high end tuners, (the Z FM-3) but removed an IF stage.

All FM tuners were mono until a stereo standard was approved by the FCC on April 20th, 1961. Daniel von Recklinghausen, Scott's chief engineer, a key inventor, and a well known FM tuner designer was head of the FCC technical evaluation committee and oversaw field testing of the various systems. The winning system was referred to as the GE-Zenith multiplex system; and that mouthful was later shortened to just multiplex. It won out over the competition primarily for its compatibility with SCA transmissions (an important revenue producer for FM stations at that time), lower inherent distortion, and full backwards compatibility with the existing FM mono receivers in the field. FM stations were authorized to start broadcasting in stereo on June of 1961, and station conversions began immediately. That left the tuner end...

As Scott was heavily involved in the stereo selection process, they were an early proponent of FM stereo and had strategically begun placing jacks for a future decoder early on, beginning with the DVR designed tuners (the 311-A tuner in 1956) to prepare for the stereo converter. When the stereo standard was approved in April of 1961, Scott already had many compatible tuners in the field, they just needed the adaptor. A Stereo adaptor unit was ready to go almost immediately, the 335. A kit multiplex decoder followed about a year later, the LM-35. By 1962-63, all the Scott FM Tuners (save the low end mono 314) were FM MPX stereo systems; these were the 350 series tuners and the LT-110 kits. Mono FM was now passe.

Throughout its run, there were very few minor circuit changes in the multiplex; most had to do with stereo detection and switching. See "Scott Stereo History" for a detailed discussion on stereo and the multiplex decoders.

Tubes were king, until the new fangled, cooler running and more modern transistor started taking over. However, there was a steep learning curve associated with designing good transistorized units, and the early bipolar based front ends proved to have inferior performance compared to the tube units. While learning how to make good solid state designs, Scott (and other manufacturers) made a few years worth of hybrid tube/solid state tuners units as transition units before switching entirely to solid state. Scott tuners transitioned by using Nuvistors in the RF stages, and transistors in the IF and multiplex stages. These transition units were:

312-A tuner

LT-112(A) tuner, the kit version of the 312-A

4312 tuner

344-B receiver

348(A) receiver

These units were offered from about 1963 through 1966.

Eventually, all solid state units using FET's in the front end (the Z-FM-16) were phased in as minor revs to the existing line, resulting in this lineup:

312-B tuner

LT-112-B tuner, the kit version of the 312-B

344-C receiver

348-B receiver

4310 tuner

The last all tube tuner models made by Scott were the 350-D and the kit version, the LT-110(B) in 1967, and then solid state was the new king. (Sigh.)

<<Other mentions>>

- The combined AM/FM units and the shared tube IF system
- The compatron late model versions (370-B)

Block diagram and basic theory

A FM tuner in brief:

A tuner essentially converts and amplifies a specific radio signal frequency to an audio signal. Radio signals are measured in uV, or microvolts, and line level audio signals are measured in volts, a million to one difference. There is a significant amount of amplification going on in a tuner!

A typical FM tuner has these main functional blocks:

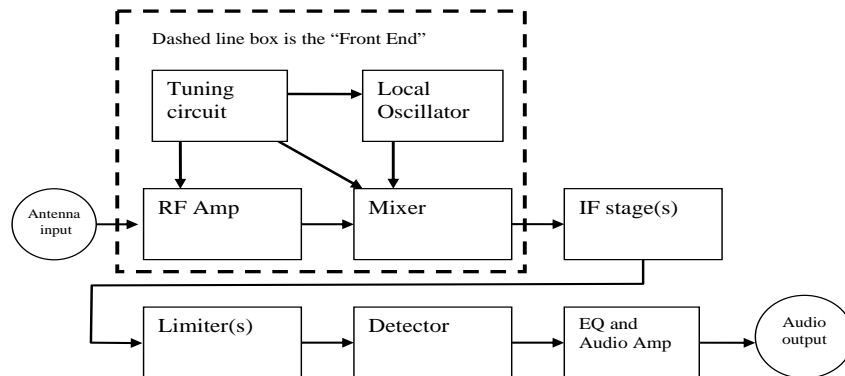

<<Add inputs and outputs to chart>>

A Scott FM tuner in fact, works in exactly the diagrammed fashion.

Scott specific FM Tuner Basic Theory

front End: RF/Local Oscillator/Mixer

This section (generally referred to as the “Front End”) handles the actual tuning and conversion chores of the tuner.

The signal is first received and amplified by the tuner's RF amplifier. This amplified signal is next mixed with a signal that is produced by the local oscillator. The combined frequency of the incoming RF and the local oscillator signals is precisely 10.7 MHz, regardless of the frequency being tuned. This process is called conversion and the resulting signal is called the intermediate frequency or IF signal. This IF signal is fed to the next stage.

Almost all HH Scott FM tuners used the same front end design. The RF/Local Oscillator/Mixer circuits are all on a small chassis with the 6BS8/6BQ7 RF amplifier tube and the 6U8 oscillator mixer tube.

Exceptions were the very first tuner, the 310(A) which used a 6BK7/6U8 lineup, and the final low cost 370/LT-111 tuner design based on a 6M11 Compactron.

Note: A poorly aligned Front End will have the stations in the wrong places, receive poorly, and may have differing sensitivity at the top and bottom of the dial.

Intermediate Frequency Stage, or IF

The IF stage is where the bulk of the signal amplification occurs. As discussed previously, all signal frequencies are converted to a common 10.7 Mhz signal via conversion in the front end. Conversion allows the Intermediate Frequency, (IF) to have good performance, high gain and good resistance to overload at minimal cost, as it can be “tuned” to amplify a very narrow frequency range.

H.H. Scott FM tube tuner designs came in two broad flavors, the professional line and the consumer line. The two lines used the same front end, it was in the critical IF and limiter stages they differed.

The professional line, the 310 and 4310 series, began with the original type 310-A wide-band (approximately a 250 Khz bandwidth) tuner design dating from about 1954. The 310 series used 5 tubes in the IF amplifier/limiter section; 3 IF amplifier stages, (typically 6AU6s) and two limiter stages; a 6BN6 gated beam limiter, followed by a 6AU6 pentode limiter to drive the Ratio Detector.

The 311(A) introduced the cost down 3-tube, IF/Limiter section used on all of the Scott consumer designs. The only deviation was the choice of the particular pentodes used, such as replacing the 1st IF tube with a 6EJ7, or the limiter with a 6HS6. The 314 & LT-10 used the pentode section of a 6U8 as the limiter and the triode section of the 6U8 as the audio output buffer, eliminating the added cost of the 12AU7 used in the original 310.

The 350/LT-110 tuner series replaced the mono 311 line, keeping the standard circuitry and adding the multiplex unit.

Note: A poorly aligned IF will exhibit an uneven action as you tune off station on either side. It can prevent the tuner from separating closely spaced stations or producing MPX stereo. In extreme misalignment cases, it can prevent any reception at all.

Limiter and AGC

The limiter is responsible for compensating for wildly different signal levels, and also distinguishing the signal from noise (natural and man-made static). Noise tends to be AM in nature, and since we are only interested in FM signals at this point, it is possible to throw away these AM signals and thus much of the noise as well. In Scott designs, the limiter is always a separate stage from the IF. An AGC loop is used around the IF and front-end to insure that the IF amplifiers always operate in the linear range and don't limit as in some other tuners. Limiting is done only by the limiter stage(s) and by the Ratio Detector in Scotts.

There were two major variations of the limiters that deviated from the standard pentode limiter scheme.

The first was in the original, non letter (sometimes also called the "A") version of the 350 stereo tuner which used a 6BN6 gated beam limiter in place of the normal pentode limiter. For whatever reason this design didn't last long, perhaps 2 IF stages were not enough to drive the 6BN6, or maybe the 6BN6 didn't drive the Ratio Detector adequately. Whatever the reason, the original 350 was replaced quickly by the 350B, which went back to the traditional pentode limiter.

The second major variation of the 3 tube IF/limiter appeared in the 350C and 350D, which again used a 6U8 as dual limiter. The triode section of the 6U8 was used as a grounded grid amplifier to drive a diode limited stage, which in turn fed the pentode section of the 6U8, which drove the Ratio Detector. A special IF transformer was used with a tapped secondary to drive the low impedance input of the grounded grid triode stage.

Note: Note: If this circuit is not working correctly or is misaligned, the tuner will exhibit odd gain problems, either distorting on strong stations or not receiving weak ones.

Metering

The most common Scott tuner designs used a signal strength meter driven from the AGC signal developed in the IF stage.

This meter looks like this when the tuner is off:



(This is a photo of a Scott LT-110 tuner.)

Notice that the meter rests at full scale when off. This is normal.

When the tuner is first turned on, the meter lights up but stays at full scale.

As the tuner starts warming up (appx 15 seconds), the needle moves down scale about half way.:



Finally, assuming you left the tuner tuned to a station, the needle moves back up scale to indicate signal strength and best tuning.



One typical variation was to substitute a 6FG6 “magic-eye” for the signal meter.



Here's a picture of a 314 tuners "magic eye" with the tuner tuned off station, causing the eye to open. The eye will close (be brightest) when on station. In other words, adjust the tuning dial for the narrowest vertical dark band. A strong station may cause the dark area to entirely disappear, and no station will cause a wide dark band as shown.

<< Describe the local/DX function on the tuner and the meter. >>

The hybrid 312-A and the kit version, the LT-112(A) also had a center station meter switch. This indicator is used to precisely tune to the center of the broadcast signal. This signal is derived from the next stage, the ratio detector.

Ratio detector

The ratio detector is responsible for separating the phase modulated audio signal from the IF signal. The IF signal is discarded, and the extracted audio signal is passed to the final audio amplifiers and equalization stages.

Scott tube tuners use a wideband ratio detector circuit design; according to Scott, the ratio detector offers additional limiting characteristics. Virtually all the tuners used a 2 MHz design. The only known variations are the high end tuners (the 4310 with a 2.5 MHz design and the 4312 with a 3 MHz design), and the low end 370/LT-111's with a 1 MHz design.

<<Note: There are some claims that the 310-E and perhaps the 4310 used a Foster Seeley Discriminator instead of a ratio detector. No backing data yet, and this is not mentioned in the marketing specs and brochures.>>

All models use germanium diodes in the ratio detector. There are a couple of minor variations in the detector stage topology, none that affect the alignment process.

Note: The ratio detector alignment has the greatest overall effect on audio quality. Even a slight misalignment will cause high levels of distortion in the audio, a lopsided tuning action when tuning off station, and can completely kill the stereo pilot signal. A bad diode will cause high distortion, as will the smoothing capacitor. The smoothing capacitor (a small value, low voltage electrolytic) should be replaced as part of the refurb process.

Some details on the Ratio Detector topologies

Scott monophonic tuners used an unbalanced ratio detector, while the later stereo tuners <<with the possible exception of the original 350 - need to check >> used balanced ratio detectors. This difference does not affect the alignment process. It is presented here as a reminder to the more technically inclined to help preserve the historical information on these circuit designs.

The essential difference between an unbalanced and a balanced ratio detector is that in the unbalanced ratio detector, the output is taken between one end of the large stabilizing capacitor, and the tertiary winding, while in the balanced ratio detector the load resistor across the large stabilizing capacitor is split into two equal parts, and the output is taken between the junction of these two resistors, and the tertiary winding.

The balanced ratio detector will have a zero DC voltage at the output when tuned to the center of the channel, while the unbalanced ratio detector will have a large DC voltage under this condition. Typically the junction of the two resistors in a balanced ratio detector was grounded, and the output was taken from the tertiary winding. The 350B is an example of this connection.

In the 4310 the tertiary winding was grounded and the output was taken from the junction of the two resistors across the large stabilizing capacitor.

In the 310-E, and most of the Scott tuners with later design stereo decoders, neither end of the balanced ratio detector was grounded so that the signal and an inverted version of the signal could be taken from opposite ends to simplify the stereo decoder circuit.

Scott FM Tuner theory and history - wrap up comments

The Scott FM circuit topology remained remarkably consistent throughout the entire tuner product line, with only minor variations in number of IF stages and some tube substitutions. Most models used a standard 5 tube design (2 RF, 3 IF/limiter) consisting of the typical Scott FM tube lineup: A 6BS8/6BQ7A cascode RF amplifier, a 6U8/6GH8A oscillator/mixer, and three 6AU6's in the IF/limiter circuit. These were all common and readily available tubes at the time, and are still readily available today as NOS.

When properly aligned, this vintage Scott circuit has excellent performance, especially by today's standards. And since these units were designed during the peak of FM interest, they have a full range frequency response and only specialty high-end tuners can better its sensitivity and selectivity performance. (As a comparison, the tuners in today's home theater receivers are horrible.)

CHAPTER 3

*Tuner Evaluation
and
troubleshooting*

This chapter contains:<<TBD list of major topics>>

Tuner Evaluation

Pre flight checks, or what to do before you plug it in!

- Verify unit is unplugged!
- Check fuse for correct value.
- Turn on power switch (the unit is still unplugged)
- Test AC line for shorts and for conduction to the chassis
- Verify AC power cord is safe (no cracks or damage.)
- Verify power transformer resistance OK.
 - Primary should be about 2-20 ohms
 - Secondary HV should be about 40 ohms
 - Filament and bias around 1 ohm
- Flush all switches and pots with cleaner.
- Clean the ground wipers on the tuning capacitor.
- Pull the rest of the tubes, labeling them as needed. Test on gM tester to weed out obviously bad ones.
- Clean tube pins and re tension sockets as needed.
- Using a soft bristle paintbrush, dust off the chassis, especially the silver plated front end (or the copper front end in the earliest models. Be very careful of the lettering!
- Replace capacitors: output coupler(s), ratio detector smoothing electrolytic, and multiplex coupler where applicable.
- Replace tubes.

Safe power up process (Smoke is bad!)

<< EDNOTE: Variac usage goes here, as does looking at AC and DC voltages>>

FM Tuner Listening and Subjective Evaluation

- Turn tuner on. Verify the meter action works correctly during warm up, see See “Poor meter action, sound OK” on page 29.
- Switch to mono, if applicable.
- Sensitivity - A 2 foot length of wire should pull in local stations cleanly, meter signal strength should read midway or better.
- Tuning action - Maximum signal on meter should correspond closely to minimum distortion of the signal, and the signal should fall off equally on both sides of the maximum. (If the station gets louder or cleaner off center, the ratio detector is probably misaligned.)
- If the tuner seems like it's working pretty well, leave it on for 1/2 hour or so and see if the tuning drifts. Stay nearby in case of problems!

AM Tuner Listening and Subjective Evaluation

- Sensitivity
- Tuning action
- DX and local settings can affect some or all of sensitivity, selectivity, and audio frequency response on some models.
- Whistles

Tuner Troubleshooting section

No power (no lights and no filaments glowing)

- Blown fuse
- Bad power cord
- Blown power transformer. (Rare on tuners, but “Oh No”!)

No sound

- No power, either AC main, B+, or filaments
- Audio Level setting pot full CCW
- Mute control set too high
- Bad audio output tube
- Bad relays or control circuits on 310-D/E and 4310

Hum in audio

- Bad audio cables
- Bad filter capacitors in B+ or filament supplies

Distorted sound

- Misaligned ratio detector
- Misaligned limiter
- Coupling caps bad
- Tuner is plugged into tape head or phono inputs on preamp
- Bad detector diodes or leaky smoothing cap.

Poor sensitivity

- Weak front end tubes
- No antenna
- Misaligned front end (RF circuit)

Poor selectivity

- Misaligned IF section
- Weak IF tubes

Poor meter action, sound OK

- Little movement - misaligned IF section (i.e. low signal)
- Weak tubes
- An overly vigorous meter action (wild swings) can be caused by the limiter being misaligned, or a leaky smoothing capacitor; typically a .1, C13 in the AGC circuit.

Mono vs. Stereo - no stereo or distorted sound

See “Scott FM Stereo Multiplex decoder”

CHAPTER 4

*Scott FM Tuner
Alignment Process*

This chapter contains:<<TBD list of major topics>>

About Aligning a Scott FM Tuner

Generally, the idea is to align the IF stages first, the ratio detector next, and finally the RF stage. If the tuner has a multiplex decoder, it should always be aligned last, if at all. It is quite common for a poorly aligned tuner to prevent the multiplex from working at all, so it would follow that you should always align the tuner first and then check for multiplex stereo operation. It may suddenly be “healed” once the tuner is working properly.

These tuners are analog systems. Although that may seem like stating the obvious, what it really means is there will typically need to be trade-offs made for best overall performance, and there may not be an absolute “best” alignment point for a particular tuner, just the best trade-offs.

FM alignment - No instrument alignment techniques

FM alignment - Official Scott EZ-A-LINE®

<< The next few pages to be filled in with scans of the Official Scott Factory Tech Bulletin and the EZ-A-LINE® process scanned from the LT-10 assembly manual.

Alignment Without Instruments: Meter Method

Scott's EZ-A-LIGN method is a very useful guide for setting up a kit tuner's IF stage and its instructions, which include adjusting the third IF downward toward the first IF stage that is on the front end plate. These IFs are all the same. Add one and a different detector and you get the 310 IF. E-Z align does not cover the 310 Foster-Seeley circuit, but all of the other circuits are much the same. <<Settle the question of the FS issue>> The final can in all non 310 IF tuners uses a ratio detector on the secondary, a final limiter on its primary.

Assuming you have a tuner that is Scott and it is known to be inferior in performance to a similar Scott model, you can assume that once any gross problems are dealt with, a non-instruments adjustment will offer some improvement. The Scott method utilizes the tuner's meter as an indicator of alignment success, and tuners like the 300, 320, 370, or 399 with beam eye tubes can offer a great deal of extra precision to the task. The meter works, but as you refine your settings, your ears will be your most important tool.

Although there is no set amount that you should consider adjusting transformer slugs, there are about 10 turns end to end in each. Be very careful when you turn the slug. It is fragile. If a transformer has lost attenuation, often the slightest adjustment will cause the performance of the tuner to improve. If the transformer is, on the other hand, off setting, you may have to search around. Make a note of the loudest amplitude. This is the center band. Sidebands will be 6 or more dB off the center point. It's possible to think that you have gotten things right only to discover that your alignment is based on a side band. It's unlikely that such an alignment will give successful results with stereo, although it may seem acceptable for mono.

Scott suggests that the detector primary (T4 in a 350/LT110, T304 on a 312) be set at 4.5 turns from a fully extended or CCW position. There has been much discussion about the art of adjusting the filter. I suggest that you adjust for maximum clarity which is that point prior to obvious distortion. Assuming that the tuner's multiplex adaptor is properly set up, the detector secondary can be set for best stereo performance. Here, I suggest using the quietest portion of the stereo channel as the center point of the detector channel.

This Scott "no instruments" alignment given below applies specifically to Scott solid state tuners, but the rules of alignment apply as well to any other Scott tuner, with the exception of the 310 series. Keep in mind, however, that like the 310 tuners, the 312 has one more IF stage than a 311 or a 350 style tuner.

EZ-A-LIGN procedure

Do not make any adjustments on any of the subassemblies unless directed to do so; many of these have been permanently set at the factory.

1) Place the tuner on its right side with the transformer down. It should still be connected to the amplifier so that you are able to hear the tuner.

Set the tuner front panel controls to show:
FUNCTION -- Normal ; SELECTOR -- Muting Off ; METER -- Align.
The antenna should be bypassed (jumpered) with a bus wire.

Carefully tune for an area on the dial where only interstation noise is heard and no station is received. Do not move the tuning dial again until instructed to do so.

- 2) Please read all of this section before proceeding.

With an alignment tool with a combination hex/screwdriver, proceed to align the instrument.

All of the transformer cans contain compressed powdered iron slugs which are threaded into the body of the transformer for adjustment. Be careful not to push down too hard when seating the tool into the slot or hex openings.

In all of the following adjustments you should not have to adjust the slugs more than one half turn in either direction from its original position. Exceptions to this may be the top of T201 (secondary of the first IF can) and T304 (secondary of the detector can), where you should not exceed one full turn in either direction. The lettering on the side of the alignment tool will guide you in figuring a full or partial turn.

In the following steps you will be adjusting the slugs for maximum meter indication. At the same time you should be listening to the hiss (noise) from the speakers, since maximum hiss will occur at the same point as maximum meter indications.

If at any time during the alignment procedure you hear a radio station, begin again. In extreme cases where you may be living next to a radio station's transmitter, the bottom cover may have to be installed during these adjustments to prevent reception of the station.

In adjusting for maximum meter indication, turn the slug to obtain maximum meter reading and slightly beyond and then turn back the slug to maximum so that it is mechanically centered at the maximum noise point. During most of the adjustments, the meter action will be very slight, thus you will have to look very carefully to insure a maximum meter reading.

- 3) Locate T201 on the front end.

Insert the alignment tool into the top slug of T201 (secondary of 1st IF can) and adjust for maximum meter indication.

Repeat for the bottom slug of T201.

Go back to the top slug of T201 and touch up the adjustment.

Adjustments on the following IF transformers will be done in the same manner. Adjust the top and bottom slugs of T301, T302, T303, and T304 for maximum meter indication.

Repeat the entire procedure above (section c) once more.

- If your tuner has a Center tuning feature, proceed to step 4. Otherwise you are finished.

- 4) Set the METER switch to Center Tuning.

Adjust the top slug of T304 (secondary of detector can) until the meter needle is centered between the two larger black rectangles.

- If your tuner has a Stereo Threshold Control, proceed to step5. Otherwise you are finished.

5) Remove the bus wire from EXTERNAL ANTENNA terminals and connect a dipole antenna to these terminals. Set the SELECTOR switch to Auto Stereo - Muting Off.

Tune to a point where no station is received.

Locate the Stereo Threshold Control (R605) on the chassis.

Turn the Stereo Threshold Control completely counterclockwise. The stereo indicator should light.

Slowly turn the control clockwise until the light just goes off. This is the normal setting for the Stereo Threshold Control.

If the Stereo indicator light does not come on using the above procedure, turn the Stereo Threshold Control completely counterclockwise. The stereo indicator light should not come on when you tune to an FM station which is broadcasting in stereo.

FM alignment - Instruments

Instruments required

- A low distortion FM signal generator. Must have less than .2% distortion to align the ratio detector, needs to have a 10.7 MHz IF sweep/birdie capability to align the IF strip, and needs to have an adjustable RF output level and a full band FM broadcast signal output to align the front end. If you want to be able to align the multiplex decoder unit, your generator will need to generate the special stereo signals as well. See Chapter 5, "Tools required" for more information on multiplex tool requirements.)
- An oscilloscope of at least 100 MHz bandwidth
- A distortion meter capable of resolving to at least .1% (a tenth of a percent.)

Instrument Limitations

The FM signal generators of the same era as your Scott tuner are generally not up to the task of aligning a Scott correctly. A Scott tuner is capable of very high quality audio, but only if carefully and correctly aligned. In particular, aligning the IF stage for best selectivity and sensitivity, aligning the RF stage for correct tuning and sensitivity, and adjusting the ratio detector for lowest THD requires a very good signal generator. Unless you have a carefully aligned, modern, reference quality FM signal generator, it will be difficult to optimize the alignment of a Scott FM Tuner.

Authors note on signal generators:

I currently use a Sencore SG165 FM signal generator for RF and IF alignments. This unit is accurate enough to use for a Scott, but only after it is carefully calibrated.

<< pic here >>

I also use a Leader SG321 for stereo multiplex alignments and general FM audio testing.

< <pic here>>

A properly restored Scott Type 830 generator could also suffice, should you happen to have one of these rare units laying about.

<<picture of Scott 830 here>>

Sweep alignment vs max amplitude techniques

Scott specifically recommended against using the sweep/marker technique for FM tuner alignment in their service notes. This is rather a puzzle, as I have consistently gotten better alignments using a modern sweep generator than the maximum amplitude technique espoused by Scott. The maximum amplitude technique tends to emphasize sensitivity over selectivity, causes higher distortion in the detector stage, and contributes to an asymmetric tuning action.

I have been unable to determine if the Scott recommendation was based on failings of the equipment of the day, tradition, a cost saving measure the factory used, or was just a simple way to make sure the factory techniques could be matched in the field. In any case, I recommend using the sweep technique with a modern sweep generator to get the best performance from your Scott FM tuner.

Aligning the tuner

IF strip

In my opinion, the IF stage is best aligned by using a FM signal generator with swept IF marker (or birdie) capability and a scope setup in the special marker hookup.

The secret to a good IF strip alignment is to keep the injected signal level as low as possible. If the meter is at 3 or so (or about the halfway closed for the eye based units) then turn down the RF input signal. If you have too strong a signal, the limiters will kick in and prevent an accurate IF alignment.

The hookup

To correctly align the FM IF strip you need to know a few assumptions that “everyone knew” in the 50’s, and so no one bothers to tell you them anymore. Things like:

- Your scope has a X/Y or Lissajou input capability.
- You have a 60 Hz signal to use with the X input, either internally to the scope or an external one.
- You know how to hook it all up. This picture (lifted from my Sencore manual) implies a simple little hookup.

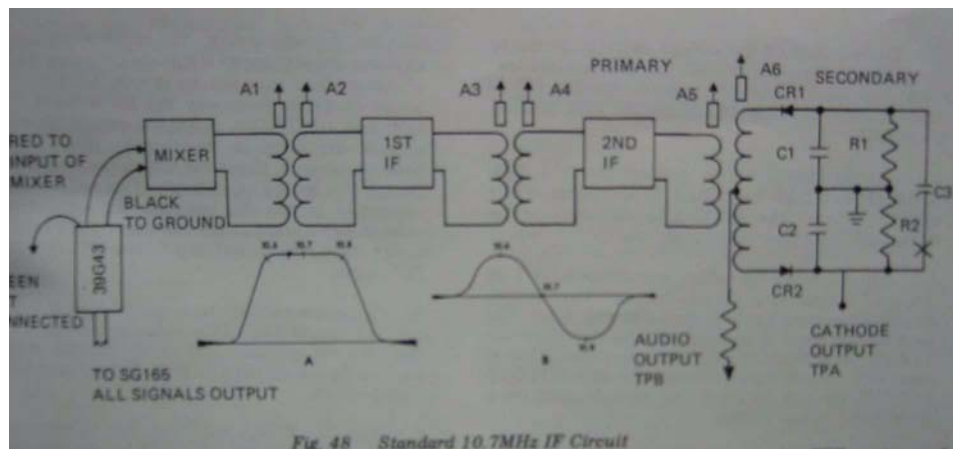

- What's not shown is a few important details:
- The scope is set for XY input (sometimes called the lissajou setting.)
- The X input on the scope is driven from a stable, low distortion, 60 Hz sine wave.
- The Y input is going to the ratio detector connection on the signal generator.
- The generators output is hooked up to the tuners **mixers** input. On a Scott, the mixer is inside the silver can, so the hookup looks like this. The clip lead is on pin 2? of V202

(the 6U8), which is the same hookup point for all the two tube "Silver plated front end" Scott tuners.



Be extremely careful to not physically move or bend anything inside the silver compartment! Even the slightest change here can seriously throw off the tuners alignment and sensitivity.

- Also, you were supposed to know to disconnect the smoothing cap from the ratio detectors load resistors.

<<picture of load capacitor here>>

You know, little stuff everyone knows...

IF Nuts and Bolts

All the pretty pictures in the signal generator guides show an IF response picture that looks something like this.

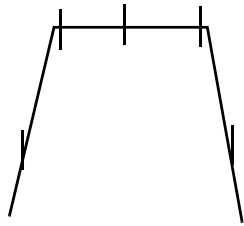

That nice little drawing is supposed to represent what you see on a scope when you have aligned the IF strip correctly. Ho ho.

I used two tuners as the samples for this article. Tuner A is a 314, Tuner B is a 333-D. The IF alignment of Tuner A looked like this to start with.

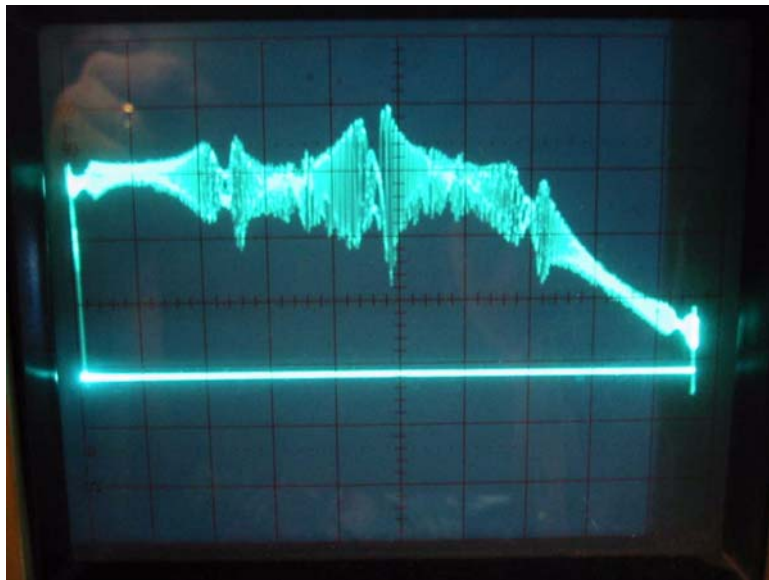

and Tuner B had this rather odd response.

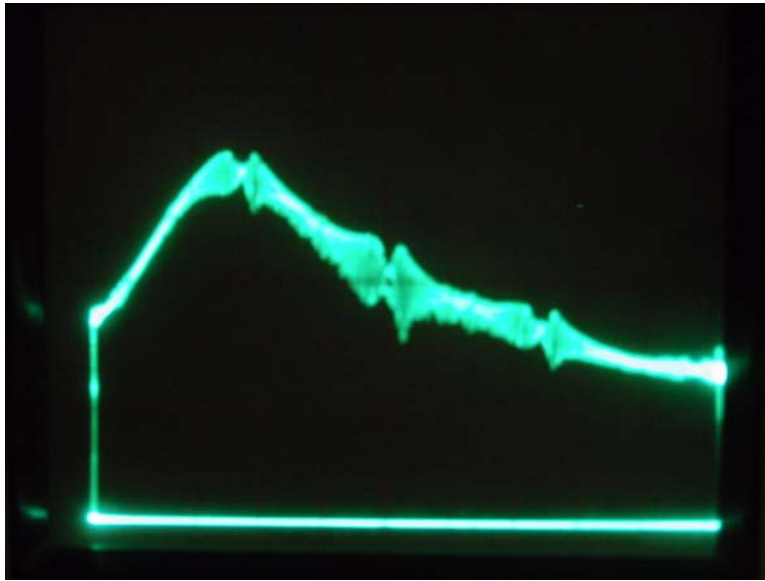

Messy, huh? Neither one is aligned anywhere close to being correct. Both of these tuners were hard to tune, the audio quality was mediocre, the meter action was poor, and they distorted unevenly as I tuned off center of the station. As indicated in the evaluation section, this is symptomatic of poor alignment, and here's the proof!

If you look carefully, you can see the markers as the "glitches". The center one is the desired 10.7 MHz center frequency, the ones to each side are 10.6 and 10.8 MHz bandwidth edges, and out at the screen sides are the boundary 10.45 and 10.95 MHz markers.

The idea is to tune for the center marker (the 10.7 MHz) to have maximum amplitude, the 10.6 and 10.8 markers to be within 90% of the center markers amplitude and even with each other (which means the IF response is symmetrical). This will be the best overall bandwidth and gain setting. But wait! You also want the outer pattern sides to be as steep as possible (this affects selectivity and capture ratio) so you are also tuning for those outer markers to be down towards the baseline, at least 40% down from the upper ones. This is where those trade-offs will come in, as the various parameters interact. A lot.

To actually do the alignment, it's helpful to have a pair of alignment tools and adjust both the top and the bottom of the IF can slugs together. Starting with the first IF can, iteratively adjust the IF transformers. A little bit goes a long way, it's rare to tune more than a turn or two either way, and as mentioned earlier, best is somewhat subjective. I prefer to go for a flatter top over steeper sides, as I like the widest bandwidth (i.e. lowest distortion) over best selectivity. But then I don't live in a city where the FM band is terribly crowded either.

Now, Tuner B's grotesquely asymmetrical response meant the ratio detector was really out. I twiddled the ratio detector a bit to give a more symmetrical response before

beginning the IF alignment process.

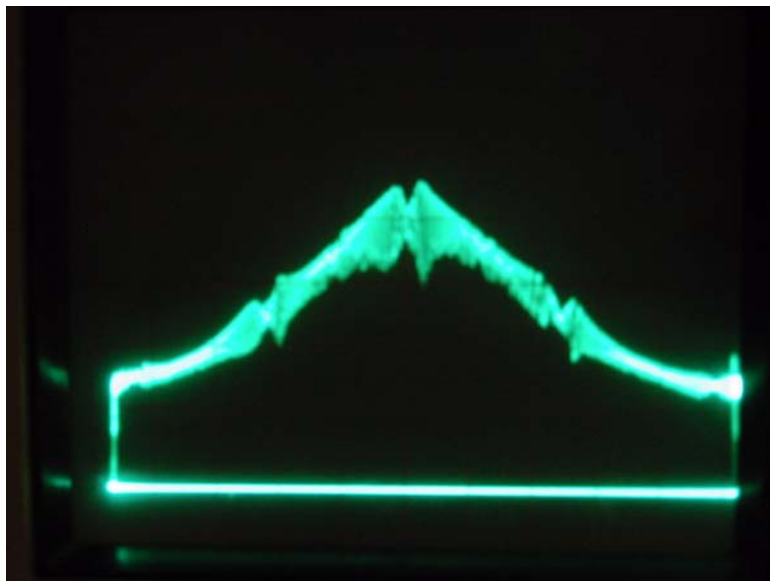

(The ratio detector will be fine tuned later for lowest THD.) This response is still way too “pointy”, but that will be addressed by aligning the IF correctly.

Here’s tuner B shaping up after a single adjustment iteration through the IF cans.

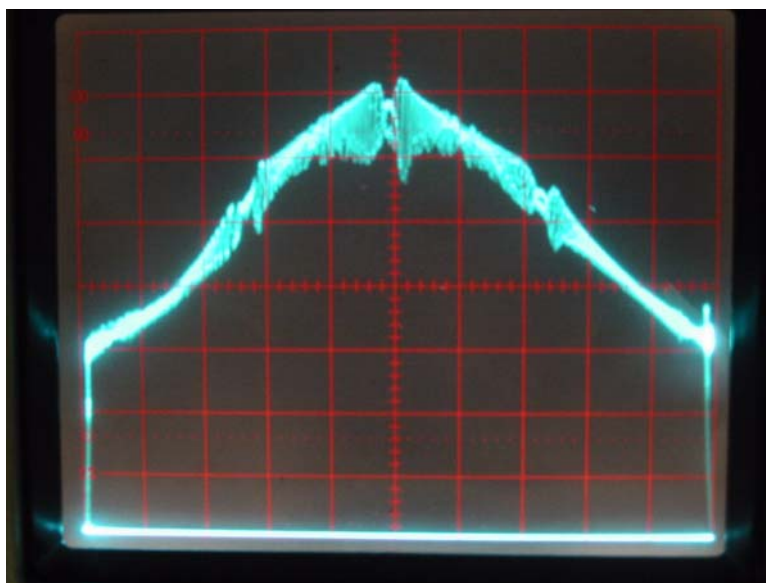

Notice the amplitude from the DC baseline to the peak is much higher now, which means the sensitivity of this set will be immensely improved.

Finally, a decent IF alignment pattern will actually look something like this one from Tuner

B. (Since tuner B was such a great example, I won't be showing tuner A's results. They

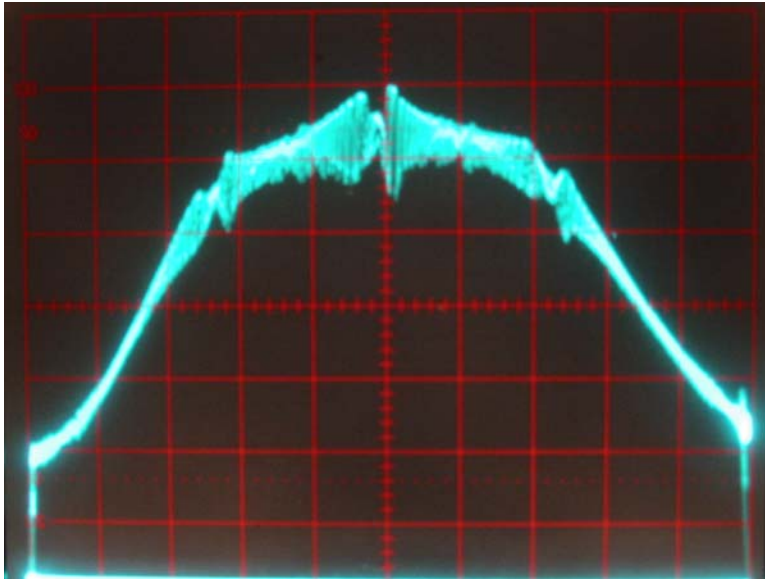

looked much the same anyway.)

Ratio detector

Aligning the ratio detector is not as simple as Scott makes it sound. The point of maximum amplitude (as viewed on a scope or a meter) isn't usually the point of lowest distortion, and it's pretty fussy about center frequency tuning.

The ratio detector is best aligned via a 400 Hz low distortion sine wave feeding the FM RF signal generator. The signal is fed to the tuners RF input, the tuners output is fed to the THD meter and the scope. Adjust the signal level to be just strong enough to get a clean signal; you don't want the limiter kicking in. It is common for the THD meter to read 10-30% at this stage, don't panic.

The ratio detector is then adjusted for lowest THD at max meter (or meter center). Carefully tune for the maximum meter indication (or center station for some tuners), while keeping an eye on the THD meter. It could be swinging around wildly, but generally getting better when you're closer to the center point.

Now adjust the ratio detectors secondary (top slug) for lowest distortion via the THD meter. Sometimes you must make a slight trade off of THD vs. good symmetry when tuning off station and you will probably need to touch up the primary (bottom slug) as well. In my case, Tuner A adjusted down to about .7% and Tuner B adjusted down to about .5% THD in mono.

Editorial Note: I have been informed that the Scott factory peaked the detector primary for maximum output with a weak generator signal (no limiting.) Then they adjusted the secondary for lowest harmonic distortion with a strong generator signal (full limiting.) I have not compared this variation with my own technique to comment on whether this will yield any improvements.

Another ratio detector alignment method is to use the sweep markers, consult your signal generators manual on how to do this.

And yet a third method is to use your ears and an oscilloscope, and adjust for the cleanest sine wave. The ears method is discussed in detail in the "no instruments" section of this document.

I have found these later two can yield decent results, but the THD method is by far the most precise.

R.F. or Front End

Aligning the front end is actually adjusting two different parameters, accuracy in tuning and best RF gain. Compared to the ratio detector and IF section, this alignment is fairly simple, unless some helpful person has been mucking around in the coils and leads inside the silver can. Then all bets are off. :-)

The general idea is to find an empty spot on the dial at the lower end of the dial (88-92 mHz) and adjust for best gain, and then find a clear spot at the high end and adjust for dial accuracy. Most of the time that's it. If someone has been tweaking in there already, you may need to adjust the accuracy at the low end as well.

The RF stage is aligned by feeding a low amplitude FM RF signal into the tuners RF input. The tuners output feeds the scope, although I find the Scott tuning meter is usually a more accurate indicator for this operation than the scope.

The secret to a good front end alignment is to keep the RF level as low as possible. If the meter is at 4 more (or about the halfway closed for the eye based units) then turn down the RF input signal. If you have too strong a signal, the limiters will kick in and prevent an accurate alignment.

To accomplish the RF alignment, hook up your FM RF signal generator to the antenna input and tune the units to your lower end clear spot. Hook the scope to the audio output. Adjust the generator to generate a 400 Hz tone, and turn down the RF gain as low as possible and still get a reasonably clean signal. The meter on the Scott should be midway or less. Keeping an eye on both the Scotts meter and the scope, adjust the FM ANT and FM RF slugs for maximum signal and highest meter reading.

Editorial note:

I have observed most Scotts have significant sensitivity interactions with the antenna, where changing the type of twin lead can also require retweaking the antenna coil. I theorize slight impedance changes throws the antenna trim off. Not surprisingly, I don't see this effect when using coax and a 300-75 ohm transformer. Since I use coax for distribution in my house, all my Scott tuners are used and aligned with a transformer attached to the antenna in screws. The transformer also prevents some nasty ground loops from causing system hum. Highly recommended.)

<<Show a pic of the typical radio Shack 75-to-300 ohm transformer attached to a Scott tuner and list RS part no. >>

Now tune to the upper end, (around 106-108) and adjust the FM OSC for correct dial accuracy. Check the tuning accuracy at both ends and the center of the dial. Usually it's spot on, but if not, the next procedure will take care of it.

Adjusting the tuning accuracy

Although the Scott documentation also discusses tweaking the under chassis coils, I have rarely found this to be required, and it's usually only because someone has been mucking about already. If you do need to adjust the tuning accuracy at the low end, the coil can be physically compressed or spread slightly. The problem is the silver access cover affects the tuning as well; removing it will throw off all your adjustments! So will changing the tightness of the covers securing screws. The best compromise is to only remove the center screw which permits the smaller access shield cover to be removed.

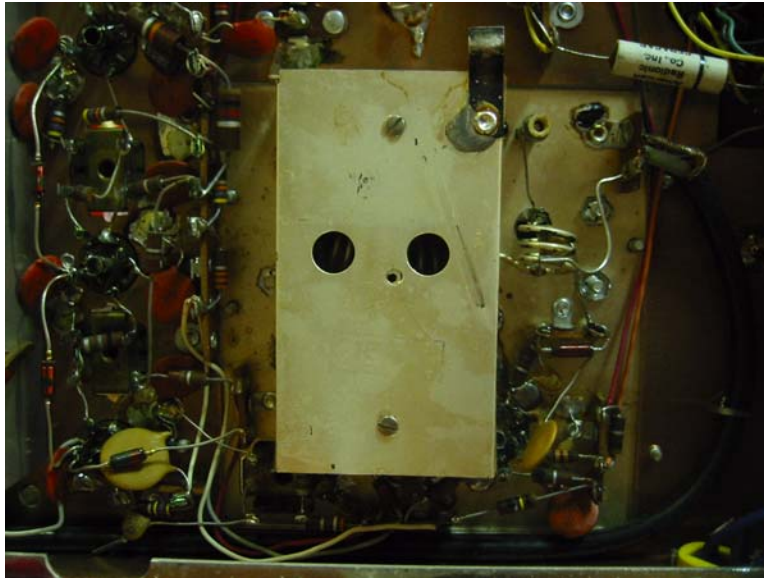

You can then carefully adjust the coils with a non metallic tool and replace the access shield iteratively until your tuning accuracy is spot on. Remember to check both the low and high ends of the dial. To do the actual adjusting, use a non conductive alignment tool to gently prod at the coils. A little goes a long way, so be gentle and make only very small incremental changes.

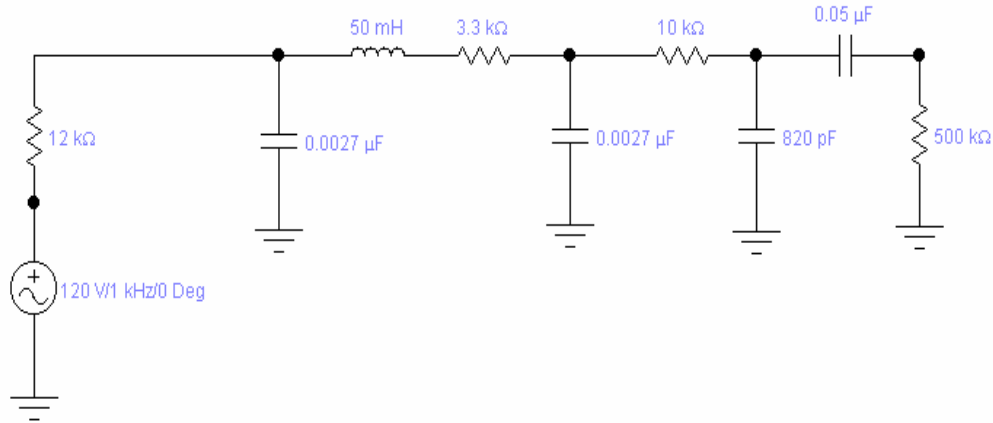

The circuit shown above is a simplified model of the 38kHz filter section between V504 and V505 (335 nomenclature labels) and provides the 75μsec equalization. The two 0.0027μF capacitors should be replaced with 0.0015μF capacitors in order to get the 50μsec equalization for use in Europe.

335 Component Labels (Left or A Channel only, duplicate for B or Right Channel)

V504-A	C534	L503	R529	C532	R526	C530	C528	R524
12AU7 Stereo Matrix	.0027 uF	50 mH	3.3 kohms	.0027 uF	10 k ohms	820 pF	.05 uF	500 k ohms (Level Pot)

333B Component Labels (Left or A Channel only, duplicate for B or Right Channel)

V503-A	C525	L503	R525	C530	R526	C529	C531	R524
12AU7 Stereo Matrix	.0027 uF	50 mH	3.3 kohms	.0027 uF	10 k ohms	820 pF	.047 uF	500 k ohms (Level Pot)

FM tuner mods and performance improvements

Attaching 75 Ohm coaxial cabling

The traditional way to do this is to use a 75 ohm to 300 ohm matching transformer (also called a balun, for BALANCED/UNbalanced transformer) . One end of the balun has 300 ohm twinlead to attach to the the tuners antenna terminals, the other end has the standard F connector. Simple, eh?

Unfortunately, there are two wrinkles. One is Scott FM tuners don't actually use a balanced 300 ohm input; one side of the antenna lead is grounded. Two is a great many baluns only match impedance, they don't isolate grounds. So depending on how you hook up your balun, you may get very poor reception as the signal is mostly shorted out! Another common problem is hum caused by ground loops through the cable system, a non isolating balun won't help this either.

There are several solutions to this dilemma.

1. Try reversing the balun leads to the tuner. One way may give better results over the other.
2. Use a real isolating balun transformer. The one Radio Shack sells (part number 15-1140B) is actually pretty good, and it correctly isolates the twinlead from the coaxial ground.
3. Replace or supplement the antenna screw terminals with a chassis mounted "F" connector. My experimentation has shown this direct 75 ohm connection to the Scott FM front end to be a superior method over the balun. Weak stations are about 2 dB improved in S/N, the signal strength meter reads slightly higher, and an unexpected but welcome benefit of "going direct" is the rejection of strong local stations. (This latter fact makes sense, as the twin lead on the balun serves as an unintentional short antenna.) Anyway, here's what I did on my LT-110 experimental tuner:



Observe there are no new holes in the chassis, a rule of mine! I instead carefully drilled out the rivets and removed the fiberboard with the screw terminals. In that space, I mounted a small-piece of brass stock with the F connector on it. The rivet holes are where the screws now are. Apparently the tuner was really designed for coax all along, as witnessed by the short piece of 75 ohm coax already used in the chassis to connect the antenna screws to the front end.

4. If you already have a transformer you like or need to use, or have modified the tuner for a "F" connector as discussed earlier, you may want to use a coax isolator. This will prevent nasty high voltage offsets from getting into your tuner, it will also solve the problems caused by ground loops in the cable system. Calrad makes a coax "F" isolator, (part number 75-504) that seems to work well and has only a 1.5 dB insertion loss

Reducing hum

Also see the discussion on 75 ohm coaxial cable and ground loops.

<<Discuss filtering and lead routing.>>

Improving the sound

<< Discuss replacing the audio path ceramic disc capacitors, and the the usual ceracap and electrolytics that go bad.

Changing the de-emphasis network for europe.

The US standard de-emphasis is 75 uS, while Europe uses a 50 uS value. Here is an analysis of the capacitor changes required for 50 uS . (Provided courtesy Terry Reimer.)

CHAPTER 5

*Scott FM Stereo
Multiplex decoder*

This chapter contains:<<TBD list of major topics>>

Scott Stereo History

(or so why isn't my stereo tuner... stereo?)

The short answer is stereo over the airwaves evolved in fits and starts, and the term "stereo" evolved along with it. Before the current FM multiplex stereo system was available, there was enormous pent up demand for 2 channel content over the air. After all, you could get stereo tapes and stereo records, why couldn't you get stereo radio?

Stereo by Simulcasting

The first solution to this problem was to broadcast the 2 channel content from two different radio stations. Since broadcasting stations often owned both an FM and an AM station, this seemed like a simple solution to the complicated problem of stereo over the air. Basically, the left channel was broadcast on the FM band, and the right channel was on the AM band, although these were inverted as often as not. This technique was called Simulcast, AM/Fm Stereo, or misleadingly sometimes called binaural broadcasting. This schema was indeed 2 channels or "stereo", but it's not the FM multiplex stereo we think of as FM stereo today.

Stereomaster

Scott made a special series of tuners (the 330's) to support this peculiar two station tuning schema, which essentially combined an AM and a FM tuner on one chassis with some audio switching capabilities. Here's a shot of my 330-D.



Notice it says "Stereomaster" in the center, and STEREO WIDEBAND AM FM in the lower right corner, but it's not a FM multiplex stereo tuner!

Ultimately broadcasters were unhappy about tying up two stations with the same content, and consumers were unhappy about the often severe tonal quality shifts between the two channels and the hassles involved in tuning two stations. (As a side note, the AM sections in these tuners sound quite good. They were a wideband design to attempt to match the quality of the FM side, and some have switchable bandwidth sections for better selectivity. If you like AM, check one of these tuners out.) This early stereo schema faded from the scene quickly once the multiplex system was approved, and everyone cheered.

FM Stereo Multiplex - Generation 1

The first generation FM stereo decoder arrived in the form of the 335 in mid to late 1961, and it was quickly implemented in a FM Tuner, the 350(A) (and the early kit version LT-110) and as a kit, the LM-35.

<< 335 pic here>>

However, there were still some kinks to work out. The thorniest one (after getting good quality audio in the first place) was how do you communicate the new stereo information to the customer? What was needed was two things:

- A way to detect the presence of the 19kHz stereo pilot tone and drive an indicator. This way the customer would know the signal was a stereo one.
- A method to automatically switch in the decoder for stereo broadcasts, and switch it out for mono ones. Running a mono FM signal through the multiplex decoder adds noise and distortion to the signal, especially on weak stations.

This was apparently a thorny problem as the first iteration of Scotts stereo decoders simply sidestepped the whole issue: They just have manual audio switching and an ‘idiot’ light. (Scotts advertising said “The stereo indicator shows when you are in stereo receiving position”). So if you set the decoder to stereo, the light lights and the decoder is engaged, and if you set it to mono, the light goes out and the audio bypasses the decoder circuits. The stereo light just indicates the multiplex decoder is engaged and ready to decode stereo broadcasts, not whether the signal itself is actually in stereo and needs the decoder. (If the light doesn’t come on when the selector switch is set to stereo, then probably the neon or the power supply is bad.)

As you may surmise, this was all terribly confusing to the consumer, so work began in earnest to solve the two previously mentioned problems.

Scott apparently pursued two different avenues here, an indicator approach (the Stereo Guide) and an audible tone approach (the Sonic Monitor). Different sources give different chronologies, but it appears that the Stereo Guide was the first approach and the Sonic Monitor was the second, as the Sonic Monitor specifically mentions false positive indications as a problem it solves. It is quite possible there was concurrent development going on as well.

Stereo Guide - Generation 2

The first and biggest problem was to detect the presence of a stereo signal. The first such Scott indicator is the rare Type C-55 Stereo Guide indicator (a \$17.99 option according to the 1965 price list.) The C-55 Stereo Guide enhanced the simple on/off behaviour of the static “stereo ready” front panel neon mentioned earlier into an actual stereo detection indicator. The C-55 used a 6AV6 tube in a curious little outboard chassis (We would call this a hack these days...) that drove the existing neon located at 6:00 behind the tuning dial on the tuners, and on the front panel of the outboard decoders.

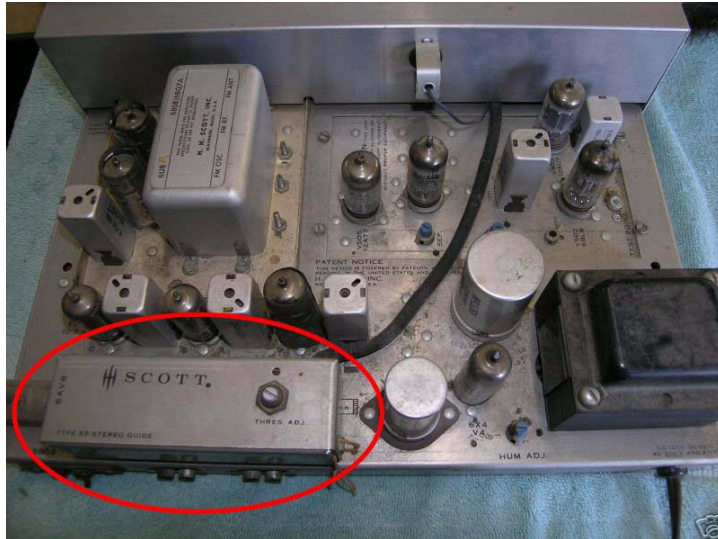

Pictured here is the C-55 Stereo Guide installed in a rather dirty 350-A. The C-55 was also available for the early LT-110(A) and the LM-35/335 outboard decoders.

It appears a Stereo Guide variant was used on the 355 AM/FM MPX tuner preamp as well. This unit uses a similar pilot detection schema to the C-55 adaptor, but features a “magic eye” indicator tube (a 6GX8) on the front panel, rather than the simple neon. Very Cool. <<Insert picture of 355 here>>

Unfortunately, these two early “Stereo Guides” suffered from false positive indications due to interstation noise, and the actual switching of the decoder audio from mono to stereo was still manual. Both quirks apparently proved to be annoying to customers, as other solutions were later implemented.

Sonic Monitor - Generation 3

The "Sonic Monitor" switch was another early attempt to resolve the dilemma of indicating real FM multiplex stereo signals.

The Sonic Monitor switch muted the audio and detuned the 38 kHz MPX oscillator such that a beat note with the 19 kHz pilot signal would be heard if the station was actually broadcasting a multiplex stereo signal. This allowed the customer to "hear" whether the signal was in stereo, tune for the cleanest tone, and then manually switch the decoder to the proper mode.

This schema was around for quite awhile, (from about 1962, and was still mentioned in the 1965 catalog). It is found on these units:

350-B and 350-C - FM MPX tuners

Late model LT-110(A) and LT-110-B - FM MPX tuners (kit version of the 350-B and C)

370(A) and 370-B - FM MPX tuners

LT-111(A) and LT-111-B- FM MPX tuners (kit versions of the 370's)

333 - AM/FM MPX tuner

340-A - FM MPX receiver

It might be argued that the 370/LT-111 design is a distinctly different design, as it uses two Compactrons and tube rectifiers. However, the user interface and specifications are the same as the standard generation 3 design, and so I've chosen to refer to it as a variation.

The Sonic Monitor apparently resolved the problem of the false positives of the Stereo Guide, but was greeted with another round of resounding apathy by customers. The two switch method was too complex, and it was still a manual operation to engage and disengage the decoder.

Auto Sensor Stereo Switching, relays - Generation 4

Finally, a real, honest to goodness, automatic stereo detection and switching system was finished. Scott called this circuit "Auto Sensor Stereo Switching" to distinguish it from all the other earlier attempts. It apparently was quite costly originally, as it premiered on the high end tuner 4310 tuner first somewhere around 1962, and then gradually trickled down.

"Auto Sensor Stereo Switching" is on these later model tube units:

4310 - FM MPX tuner - mono/stereo switching via relays.

310-E - FM MPX tuner - mono/stereo switching via relays.

Auto Sensor Stereo Switching, all electronic Generation 5

Finally, an all electronic method (no relays!) was perfected, and it showed up on these units:

312(A) and the kit LT-112(A) hybrid Nuvistor/SS FM MPX tuner

340-B FM MPX receiver

345 FM MPX receiver

350-D - FM MPX tuner

380 AM/FM MPX receiver

344-B hybrid Nuvistor/SS receiver

? 342

348(A) hybrid Nuvistor AM/FM tuner

About this time is when tube tuners were replaced by solid state, so our tube tuner stereo story now comes to an end.

FM Multiplex Overview

A good article (written by Daniel R. Von Recklinghausen, published in Audio Magazine, June 1961) discusses the Scott design in detail. In brief, the Scott multiplex is a time switching design. It uses the 19 kHz pilot imbedded in the FM stereo signal as the sync signal for a 38 kHz oscillator. The 38 kHz oscillator is what drives the actual time switching network, which is a pair of matched bridges. The output from the bridges feed a pair of wideband amplifiers and filter circuits, and finally an audio output stage. Like all FM stereo tuners, a filter (low pass or notch) is used to block the 19 kHz pilot from the output; this is why the upper frequency of a FM stereo signal is limited to 15 kHz.

The Scott multiplex design was a solid and very stable one and underwent very few circuit changes until solid state took over. The changes mostly centered on reliable detection of the 19 kHz pilot and automatically switching the decoder into stereo and operating an indicator.

The baseline Scott multiplex decoder is a 4 tube design.

- A 6BL8 is used as the composite buffer and 19 kHz amplifier.
- A 12AU7 is the 38 kHz oscillator driving the germanium diode switching matrix.
- A second 12AU7 is the audio matrix tube to adjust the ratio of L+R and L-R signals to insure full stereo separation.
- Finally, a 12AT7 is the audio output amplifier.

One circuit variation was in the diode bridge. Curiously, the top of the line 4310 and the bottom of the line 370/LT-111 used vacuum tube rectifiers in place of the germaniums. Another variation is the so called "3 tube" design. It's really the same first generation circuit, the output tube was just moved off of the multiplex sub-chassis to the main chassis. A final circuit variation might be the use of Compactrons, but it was only used in the budget units, the 370/LT-111 units.

Multiplex Decoder Design criteria

Separation:

30 dB @400 Hz. Typically > 25dB from 50-12 kHz). Later designs improved on this a bit, claiming 35 dB at 400Hz.

Frequency response:

20 - 15,000 kHz+/- 3dB, typically 50-12K +/-1 dB

Although a mono FM signal can be from 20-20 KHz, a stereo signal has a 20-15kHz bandwidth to make room for the stereo pilot at 19 kHz. If you are doing frequency sweeps, feeding a tuner with 15 khz or higher signal will cause frequency doubling, or odd harmonic tones in the output.

THD:

< 2 %. This is in addition to the < 1% from the FM tuner itself.

S/N:

60 dB. Stereo will always require a stronger signal than mono to be received cleanly, and the S/N ratio will always be some 6 dB worse than mono due to the multiplex encoding schema.

Evaluation

Aside from poor or no separation, beats & chirps and an odd “reverb” sound are the most common symptoms of poor multiplex alignment. These noises can also be symptoms of poor tuner alignment or functionality, or a bad or incorrect cable. Scott outboard multiplex decoder units are designed to work with cabling of 1 meter or less. Use only good quality video cables, not cheap audio cables. A cheap audio cable will kill the high frequencies and thus the stereo pilot signal.

Discussion

Multiplex units are finicky to align. It's quite unlikely you can align one well with out a good Stereo RF signal generator and scope. You may either feed a mpx signal directly into the decoder, or align the tuner before playing with the mpx unit. It is preferable to use the tuner method as there are interactions between the tuner and mpx unit; essentially the mpx unit is somewhat signal level sensitive.

It is worth repeating again... A poorly aligned tuner will prevent the mpx decoder from working.

Tools required

- A low distortion FM stereo signal generator (less than .5%) to generate the special stereo signals. It needs to have better than 30dB of separation, to be able control the pilot tone at 19 kHz, and to turn off and on the two channels independently. Many FM multiplex generators use a 400 Hz signal as the modulation signal. In my experience, this is not a high enough frequency to finesse the decoder into best separation. A 8kHz signal is recommended. (If the generator can be modulated from an external sweep source you can verify the tuners frequency response vs. separation, a good thing.)
- An oscilloscope of at least 100 MHz bandwidth

Aligning the MPX unit

None of the official sources actually cover a complete alignment, oddly enough.

<<Official Scott instructions here from the 335 service note >>.

<<Mention SAMS note 636-13 for the 335 has a process. >>

Observe SAMS are still under copyright, and may not be reproduced here.

Daevs preferred method

The following instructions are specific to the first through third generations, but generally apply to all Scott multiplex units. The whole alignment process only take about 20 minutes once you get started.

Hook up the mpx generator to the tuners antenna connection and hook up an amp and a scope to the audio outputs. Turn everything on and let it stabilize for at least 1/2 hour. Listen to some good music while waiting. If you must feed a composite signal directly into the decoder, set the level to no more than 250 mV RMS, else you will overload the decoders first amp stage

1. 67 K Adjust: Run a 67kHz signal in and tweak the 67 kHz SCA trap (L502) for minimum signal at test point A (C514, a 1.0 uF cap)
2. 19 K amp adjust: Run an unmodulated 10% pilot tone (i.e the 19kHz Khz signal) into the tuner. Disable the 38 kHz oscillator by grounding Point B1 (Pin 2 of V503, the 12AU7). Put the scope on test point B (Pin 7 of V503) and adjust the 19 kHz coil and can (L501 and T501) for max amplitude of the 19 kHz signal. This should be a fairly clean sine wave of appx 30 volts PP <<show pic>> .

3. 38 kHz oscillator adjust: Either turn off the pilot or jumper the primary of T501 to disable the pilot signal. This prevents the 38 kHz oscillator from locking to the pilot and allows an accurate 38 kHz adjustment. Put a frequency counter on point C, (capacitor C520 and two 33K resistors driving the bridges). Adjust the 38 kHz transformer T502 for 38,000 kHz. This puts you in the ball park, but the frequency counter typically loads the oscillator enough to throw it off. To adjust it precisely, you'll use your scope set to display a lissajou pattern. Feed the pilot into your scopes Y channel and put the X input on test point C (capacitor C520 and two 33K resistors driving the bridges). Adjust for the most stable figure 8. << insert picture here>>. Enable the pilot, verify the oscillator locks up to the pilot. << picture here >>. Remove the scope probe.
4. Setting the balance pot: <<Is this a DC voltage or what? If so, adjust for equal DC?>>
5. Setting the separation pot: Put both scope inputs on the two audio outputs. Modulate the left or A channel with a 400-1K Hz signal while listening to and watching the right or B channel. The idea is to tweak for *minimum* signal in the right channel, which will be the best separation point for left to right. Adjust the separation pot for minimum right channel output. You may need to tweak the 38K slug a tiny bit, it will only be a fraction of a turn if so.
Now modulate the right channel and listen to the left. Again tweak for minimum output. The best separation point isn't symmetrical; the left to right is usually a few dB better than the right to left separation. Iterate for best compromise. Repeat with a 8 kHz signal.

Validation

- 1) Verify separation is about 30 dB at 440 Hz, and about 25 dB from 50 -15 kHz. It will not be symmetrical, but there should be no wild variations either.
- 2) Verify Stereo THD at 440 Hz is about 2% for a direct feed, and about 3% if going through the entire FM tuner. Less is better, but these are typical values.
- 3) Remove the signal generator and verify a stereo FM station tunes correctly and that you indeed have stereo.

Improving the sound

<< Discuss replacing the audio path ceramic disc capacitors, and the the usual ceracap and electrolytics that go bad.>>

CHAPTER 6

Scott AM Tuners

This chapter contains:<<TBD list of major topics>>

A brief history of Scott AM tube tuners

Scott never made a stand alone AM tuner, they were always combined with an FM tuner, and these units were never offered as a kit.

Scott was into high fidelity and so the AM tuners tended towards wideband designs, with switching to reduce bandwidth (sound quality) as needed. These tuners sound startlingly good, especially compared to the junky AM tuners in today's home theater receivers.

The first AM/FM tuner from Scott was the 330/331 series; the A version was introduced about 1957. The 330 series was quite long lived, continuing through a D version in 1962. The 330's were ready to use for "simulcast stereo" broadcasts, where the AM station was intended to be fed to the left channel and the FM station was the right; although the channels were interchanged as often as not. Three AM sensitivity/bandwidth positions were provided on the 330's: Wide-Range (highest RF, IF, and AF bandwidth), Normal, and Distant (narrowest bandwidth and a low pass filter).

The 330 series was followed and replaced by the 333 series (1962-1965) which basically added the new multiplex adaptor onboard, and a simplified AM section was created by using a 2 position bandwidth stage.

There was also a cost reduced AM/FM tuner series (1957-1960), the 300 and 320. These tuners featured slide rule tuning, but were never very popular.

Basic theory and block diagram

<<Most of this section is lifted directly from the HH Scott website. credits go to ?>>

All Scott AM tuners shared the same basic AM section design. The typical Scott AM tuner section uses a four-tube/five-can lineup consisting of: a 6BA6 for the AM RF amplifier; a 6BE6 for the AM converter; a 6AU6 for the AM IF amplifier; and a 6AL5 used as the combined AM audio detector and AGC. All Scott AM tuners included a 10 kHz "whistle" filter. A 12AU7 was used for audio (line-level) amplification of the AM signal. Rectification was typically a 6X4/5, the later 333 series used a SS rectifier.

Process Discussion

Aligning an AM tuner is all about maximizing selectivity and sensitivity. Best results are obtained by aligning the IF first, the RF section next, and adjusting the 10 KHz trap last.

Tools required

- AM Signal Generator
- VTVM (AC)
- Oscilloscope.

Limitations

Tools required

Aligning RF and IF stages

(This is the "official" Scott instructions word-for-word taken directly from H.H. Scott, Inc., publication number D-333B-2

<<EDNOTE: need pics!>>

2. Connect scope and meter to tuner's recorder output jack. Switch tuner selector to AM. Connect output from signal generator (455 kc, 400 cps int. mod.) to pin 7, 6BE6 through a .047 coupling capacitor. Connect one each 33k resistors across primary and secondary of both IF trans. Adjust primary and secondary of both IF transformers (cans) (455 D) for maximum output as indicated on VTVM. Input signal should be just great enough for good signal on scope. Remove 33k resistors.

3. With 47-ohm load across output leads of signal generator, loop generator output leads around loop antenna. Set the tuner and generator to 530 kc with output from generator sufficient for output indication from tuner; adjust AM osc. coil for maximum output. Switch to 1630 kc and adjust oscillator trimmer for maximum output. Repeat until no noticeable improvement can be made.

4. At 600kc., (using low input) adjust AM Mixer and AM Antenna (cans) coils (top slugs only) for maximum output. (Editor's Note: Can positions from front to rear are: AM Antenna can, AM Mixer can, AM IF Can, AM Whistler Filter Can (positioned out of IF lineup), and AM Detector.)

5. Switch to 1400 kc. peak AM Mixer and AM Antenna trimmers for maximum output.

At 20 uv input, output should be from .8 to 1.5 v.

With modulation off at 600 kc., output should drop -15 dB; at 1600 kc. -20 dB.

With 5k microvolts input, turn modulation off. Output should drop -35 dB at both ends of AM band.

7) Whistle can (10KHz trap) alignment

Feed a RF signal modulated with a 10 KHz sine wave. Adjust the trap (usually both a coil and a trim pot) for *minimum* (i.e, maximum trapping of) signal at the output.

AM tuner mods and performance improvements

AM channel spacing is 10kHz in the US, but 9kHz elsewhere. This makes things tough if you don't have an adjustable IF bandwidth. <<Any info on changes for BW?>>

