

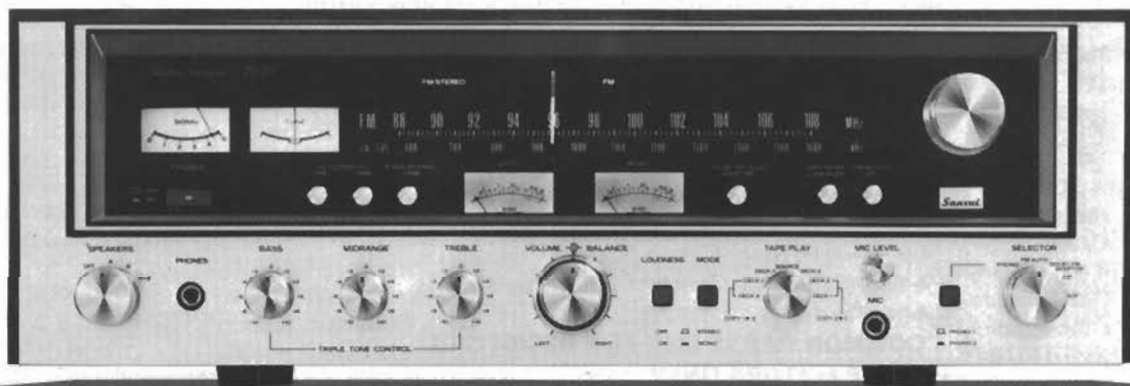

# SERVICE MANUAL

## AM/FM STEREO RECEIVER **SANSUI 7070**



*Sansui*

SANSUI ELECTRIC CO., LTD.

This service manual is designed for service engineers to repair, adjust, maintain and order the replacement parts of the 7070 correctly. When ordering the parts, use the stock number and parts name specifically referring to the Parts Location and Parts Lists. For general usage and maintenance of the unit, please refer to the Operating Instructions attached with the unit.

## TABLE OF CONTENTS

<u>Section</u>	<u>Title</u>	<u>Page</u>
<b>1.</b>	<b>SPECIFICATIONS</b> .....	<b>2</b>
<b>2.</b>	<b>ADJUSTMENTS</b> .....	<b>3</b>
2-1.	Driver Circuit Board Adjustment .....	<b>3</b>
2-2.	Power Meter Adjustment .....	<b>3</b>
2-3.	FM & MPX Adjustment .....	<b>4, 5</b>
2-4.	AM IF Adjustment & Tracking .....	<b>6</b>
<b>3.</b>	<b>THREADING OF DIAL CORD</b> .....	<b>7</b>
3-1.	Threading of Dial Cord .....	<b>7</b>
3-2.	Attachment of Dial Pointer .....	<b>7</b>
<b>4.</b>	<b>PARTS LOCATION &amp; PARTS LIST</b> .....	<b>8</b>
4-1.	F-2625 Power Supply Circuit Board (Mother Board) .....	<b>8</b>
4-2.	F-2627 Illumination Circuit Board .....	<b>8</b>
4-3.	F-2626 Power Supply Circuit Board .....	<b>9</b>
4-4.	F-2624 Driver Circuit Board .....	<b>9</b>
4-5.	F-2623 Filter Circuit Board .....	<b>9</b>
4-6.	F-2620 Equalizer & Mic Circuit Board .....	<b>10</b>
4-7.	F-2615 FM Muting Circuit Board .....	<b>10</b>
4-8.	F-2621 Accessory Switch Circuit Board .....	<b>10</b>
4-9.	F-2614 Tuner Circuit Board .....	<b>11</b>
4-10.	F-2622 Tone Control Circuit Board .....	<b>12</b>
4-11.	Figures .....	<b>12</b>
◇	<b>COMMON PARTS LIST FOR RESISTORS &amp; CAPACITORS ONLY</b> .....	<b>(Attached)</b>
<b>5.</b>	<b>OPERATION BLOCK DIAGRAM</b> .....	<b>13</b>
5-1.	Power AMP. & Protector Section Block Diagram .....	<b>13</b>
5-2.	Tuner Section Block Diagram .....	<b>14</b>
5-3.	PLL Block Diagram (IC HA1196) .....	<b>14</b>
5-4.	FM IF System Block Diagram (IC HA1137W) .....	<b>14</b>
<b>6.</b>	<b>SCHEMATIC DIAGRAM</b> .....	<b>15, 16</b>
<b>7.</b>	<b>OTHER PARTS</b> .....	<b>17</b>
7-1.	Top Side .....	<b>17</b>
7-2.	Bottom Side .....	<b>17</b>
7-3.	Exploded View .....	<b>17, 18</b>
<b>8.</b>	<b>PACKING LIST</b> .....	<b>BACK COVER</b>
<b>9.</b>	<b>ACCESSORY PARTS LIST</b> .....	<b>BACK COVER</b>

# 1. SPECIFICATIONS

## AUDIO SECTION

### POWER OUTPUT

Min. RMS, both channels driven, from 20 to 20,000Hz, with no more than 0.3% total harmonic distortion

60 watts per channel into 8 ohms

60 watts per channel into 4 ohms

Min. RMS, both channels driven, at 1,000Hz, with no more than 0.3% total harmonic distortion

65 watts per channel into 8 ohms

65 watts per channel into 4 ohms

LOAD IMPEDANCE ..... 4, 8 ohms (SYSTEM-A or B)  
8 ohms (SYSTEM A+B)

POWER BANDWIDTH ..... 20 to 20,000Hz at or below rated min. RMS power output and total harmonic distortion

TOTAL HARMONIC DISTORTION ..... less than 0.3% at or below rated min. RMS power output

INTERMODULATION DISTORTION (70Hz:7kHz=4:1 SMPTE method) ..... less than 0.3%

FREQUENCY RESPONSE (at 1 watt) ..... 20 to 30,000Hz  $\pm 1$ dB

RIAA CURVE DEVIATION (PHONO) ..... +0.5dB, -0.5dB (30Hz to 15 kHz)

DAMPING FACTOR ..... approximately 45 at 8-ohm load

INPUT SENSITIVITY AND IMPEDANCE (1kHz, for rated power output)  
PHONO-1, 2 ..... 2.5 mV/50 kilo ohms (Max. input capability: 160 mV at 1kHz, less than 0.5% total harmonic distortion.)

MIC ..... 2.5 mV/50 kilohms

TAPE PLAY, AUX ..... 150 mV/50 kilohms

OUTPUT LEVEL (1,000Hz)  
TAPE-1, 2 REC (pin jacks) .. 150 mV  
TAPE-2 REC/PLAY (DIN socket) ..... 30 mV

CHANNEL SEPARATION (at rated output 1,000Hz)  
PHONO-1, 2 ..... better than 50dB  
TAPE PLAY, AUX ..... better than 50dB

HUM AND NOISE  
PHONO-1, 2 ..... better than 70dB  
TAPE PLAY, AUX ..... better than 80dB

CONTROLS  
BASS .....  $\pm 10$ dB (50Hz)  
MIDRANGE .....  $\pm 5$ dB (1.5kHz)  
TREBLE .....  $\pm 10$ dB (10kHz)  
LOUDNESS ..... +8dB (50Hz)  
+6dB (10kHz)  
LOW FILTER ..... -10dB (50Hz)  
HIGH FILTER ..... -10dB (10kHz)  
AUDIO MUTING ..... -20dB

## FM SECTION

TUNING RANGE.....88 to 108MHz

SENSITIVITY (IHF) .....10.3dBf (1.8 $\mu$ V)  
(DIN) ..... 1.0 $\mu$ V

50dB QUIETING SENSITIVITY

STEREO (IHF) .....38dBf (45 $\mu$ V)

MONO (IHF) .....15.6dBf (3.3 $\mu$ V)

TOTAL HARMONIC DISTORTION

STEREO.....less than 0.4%

MONO.....less than 0.3%

SIGNAL TO NOISE RATIO (mono) ..... better than 70dB

SELECTIVITY ..... better than 80dB

CAPTURE RATIO ..... less than 1.5dB

IMAGE RESPONSE RATIO (IHF) ..... better than 75dB (98MHz)

IF RESPONSE RATIO (IHF) .. better than 95dB (98MHz)

SPURIOUS RESPONSE RATIO (IHF) ..... better than 90dB (98MHz)

SPURIOUS RADIATION .... less than 34dB

STEREO SEPARATION ..... better than 40dB (1kHz)

FREQUENCY RESPONSE .... 30 to 15,000Hz  $\pm 0.5$ dB

ANTENNA INPUT IMPEDANCE ..... 75 $\Omega$  unbalanced  
300 $\Omega$  balanced

## AM SECTION

TUNING RANGE.....535 to 1,605kHz

SENSITIVITY (Bar antenna) .. 50dB/m (1,000kHz)

SELECTIVITY ..... better than 35dB (1,000Hz)

IMAGE RESPONSE RATIO (IHF) ..... better than 35dB (1,000Hz)

IF RESPONSE RATIO (IHF) .. better than 30dB (1,000Hz)

## OTHERS

### POWER REQUIREMENTS

POWER VOLTAGE..... 100, 120, 220, 240V 50/60Hz

POWER CONSUMPTION.. 160 watts (rated)

400 watts, 460VA (max.)

DIMENSIONS ..... 502 mm (19-13/16") W

156 mm (6-3/16") H

371 mm (14-5/8") D

WEIGHT ..... 16.6 kg (36.6 lbs) net

18.8 kg(41.4 lbs) packed

\* Design and specifications subject to change without notice for improvements.

## 2. ADJUSTMENTS

### 2-1. Driver Circuit Board Adjustments (See Fig. 2-1 & 2-2 on page 3)

- Note:** 1. Master Volume.....Minimum  
 2. Before adjustment, run the unit for more than 4 minutes, then check and readjust necessary.

STEP	SUBJECT	EQUIPMENT	MEASURE OUTPUT	ADJUST	ADJUST FOR	CONDITION
1.	DC 0V L-CH	DC volt Meter	Speaker Terminal L-CH	VR01 F-2624	0V $\pm$ 10mV	◦ Step down meter range accordingly. ◦ Change leads polarity if meter swings backward.
2.	DC 0V R-CH	Same as above	Speaker Terminal R-CH	VR02 F-2624	Same as above	Same as above
3.	Bias Current L-CH	DC Milliammeter	F05, 07 Terminal on F-2625	VR03 F-2624	30mA $\pm$ 1mA	◦ Step down meter range accordingly
4.	Bias Current R-CH	Same as above	F05, 06 Terminal on F-2625	VR04 F-2624	Same as above	◦ Same as above

Fig. 2-1

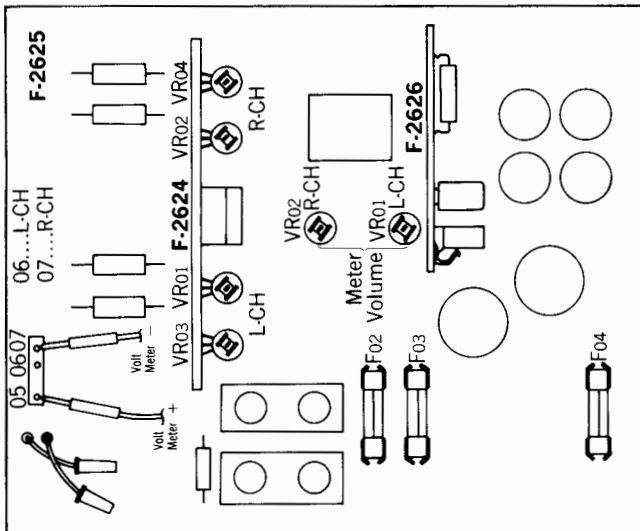
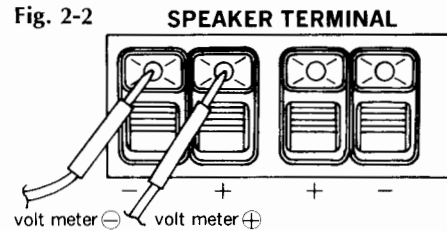
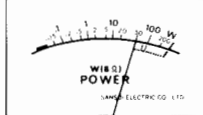

Fig. 2-2



### 2-2. Power Meter Adjustment (See Fig. 2-1 & 2-3 on page 3)

- Note:** 1. Input .....AUX  
 2. Input Signal .....Sine Wave (1kHz)  
 3. Speaker load.....8 $\Omega$   
 4. Master Volume .....Maximum  
 5. Turn VR01 and VR02 on F-2564 fully counterclockwise.  
 6. For adjustment, run the unit for more than 4 minutes after the power is switched ON.

STEP	EQUIPMENT	MEASURE OUTPUT	OUTPUT LEVEL	ADJUST	ADJUST FOR
L-CH	AC Volt Meter	Speaker Terminal L-CH	20V (50W)	VR01 F-2625	Meter Position 50W Fig. 2-3
R-CH	Same as above	Speaker Terminal R-CH	Same as above	VR02 F-2625	

## 2-3. FM & MPX Adjustment (See Fig. 2-4 on page 5)

- Note: 1. Selector.....FM AUTO  
 2. FM Muting Switch.....OFF

3. Connection.....Connect the output of genescope through 100pF ceramic capacitor.

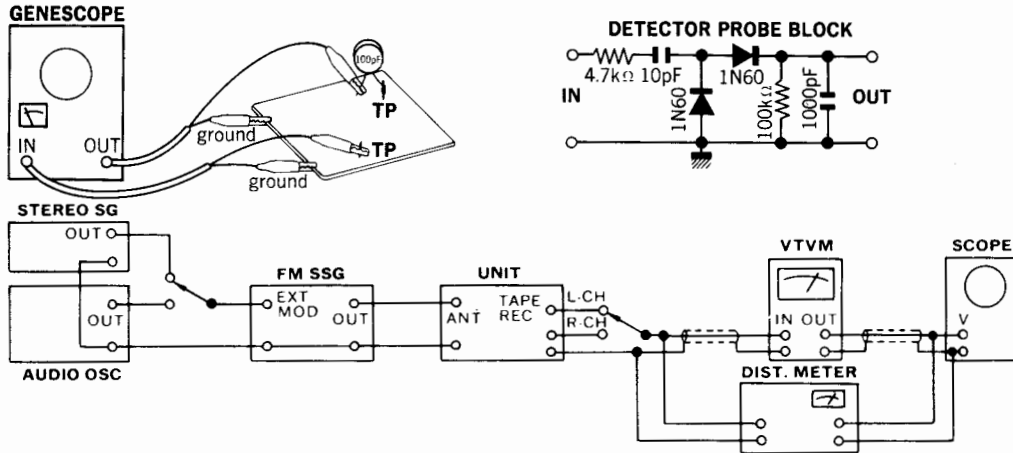

### 1) FM IF Adjustment & Tracking

STEP	SUBJECT	FEED SIGNAL		MEASURE OUTPUT	ADJUST	ADJUST FOR	CONDITION
		FROM	TO				
1.	IF Coil	Output 100dB Genescope	TP01 F-2614	TP03 F-2614 Use Detector Probe	T01 F-2614	Max. IF waveform	
		Output 90dB Genescope	Same as above	TP04 F-2614 Use Detector Probe	T02 F-2614		
2.	Discriminator Coil	Output 50dB Genescope	Same as above	TM04 F-2614	T03	Center indication on tune meter	
					T04	Max. linearity of S curve	
					F-2614	Steep linearity of S curve	
						Set output wave to dip point (It's minimum distortion)	
3.	90MHz Dial Calibration	90MHz ANT Input 60dB 400Hz (100% MOD) FM SSG	ANT terminal 300Ω	REC OUT L or R-CH VTVM & Scope	L05 F-2614	Max. Output	
	106MHz Dial Calibration	106MHz ANT Input 60dB 400Hz (100% MOD) FM SSG	Same as above	Same as above	TC01 F-2614	Same as above	
4.	90MHz RF Adj.	90MHz ANT Input 60dB 400Hz (100% MOD) FM SSG	Same as above	Same as above	L01, L02, L03 F-2614	Same as above	
	106MHz RF Adj.	106MHz ANT Input 60dB 400Hz (100% MOD) FM SSG	Same as above	Same as above	VR01a VR01c VR01e F-2614	Same as above	
5.	Signal Meter Volume	98MHz ANT Input 100dB 400Hz (100% MOD) FM SSG	Same as above	Signal Meter	VR11 F-2615	4.7 on Meter	

## 2) MPX Adjustment

STEP	SUBJECT	FEED SIGNAL		MEASURE OUTPUT	ADJUST	ADJUST FOR	CONDITION
		FROM	TO				
1.	PLL VCO Adj.	98MHz ANT Input 60dB FM SSG Pilot 19kHz (10% MOD) L-CH 1kHz (45% MOD) R-CH (0% MOD) STEREO SG	ANT terminal 300Ω	Stereo indicator	VR01 F-2614	Light indicator	Adjust the VR within center of lighting level.
	PLL VCO Adj. In case of using Freq. counter.		Make short between TP04 & chassis	TP05 F-2614 Use Freq. counter	VR05 F-2614	76kHz ±200Hz	For this adjustment, run the unit over 30 seconds.
2.	Separation	98MHz ANT Input 60dB FM SSG Pilot 19kHz (10% MOD) L-CH (0% MOD) R-CH 1kHz (45% MOD) STEREO SG	ANT terminal 300Ω	REC OUT L-CH VTVM & Scope	VR02 F-2614	Min. Output -35dB	Confirm separation L-CH → R-CH -35dB
3.	Muting level & indicator level	98MHz ANT Input 18dB FM SSG Pilot 19kHz (10% MOD) L-CH 1kHz (45% MOD) R-CH (0% MOD) STEREO SG	Same as above	Stereo indicator	VR12 F-2614	Muting level 18dB Indicator lighting level 18dB	

### ◆ Adjusting or Connecting Points on AM, FM & FM MPX circuit board, F-2614 & F-2615

Fig. 2-4

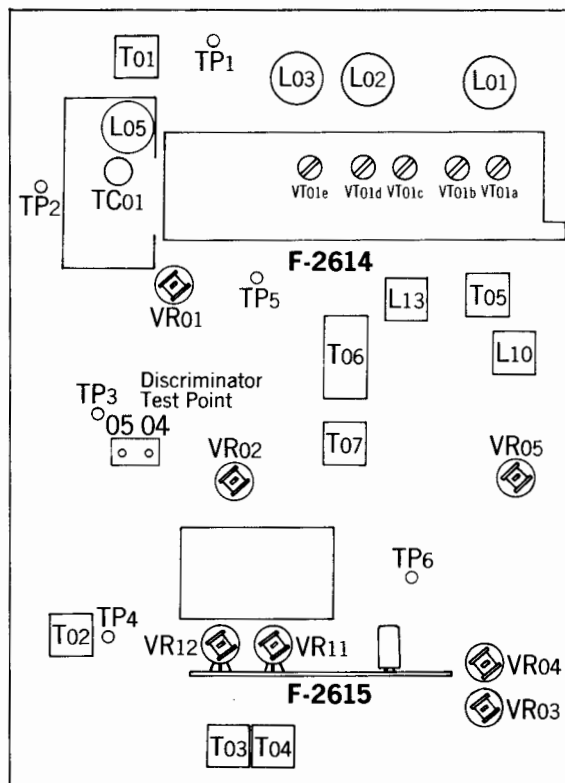

## 2-4. AM IF Adjustment & Tracking (See Fig. 2-4 on page 5)

Note: Selector.....AM

2. Confirm start point of dial pointer before alignment.

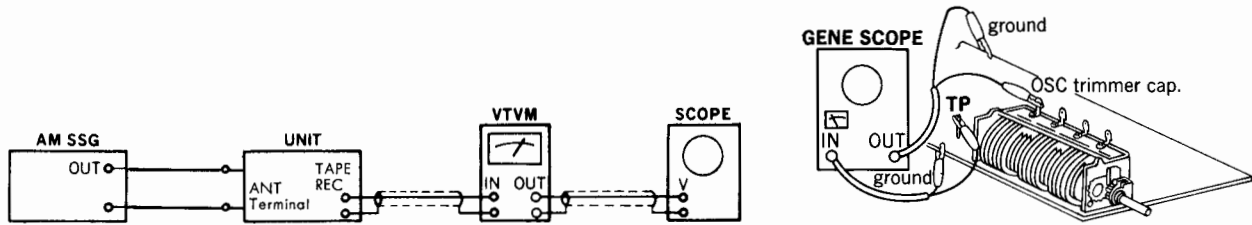

STEP	SUBJECT	FEED SIGNAL		MEASURE OUTPUT	ADJUST	ADJUST FOR	CONDITION
		FROM	TO				
1.	IF Coil	Genescope Output 65dB	VT01b F-2614	TP06 F-2614	T06 F-2614	Max. IF waveform	
2.	600kHz Dial Calibration	600kHz ANT Input 60dB 400Hz (MOD 30%) AM SSG	AM ANT terminal	REC OUT L or R-CH VTVM & Scope	L-13 F-2614	Max. Output	
	1400kHz Dial Calibration	1400kHz ANT Input 60dB 400Hz (MOD 30%) AM SSG	Same as above	Same as above	TC05 F-2590	Same as above	
3.	600kHz RF Adj.	600kHz ANT Input 60dB 400Hz (MOD 30%) AM SSG	Same as above	Same as above	L702 Bar Antenna	Same as above	
	1400kHz RF Adj.	1400kHz ANT Input 60dB 400Hz (MOD 30%) AM SSG	Same as above	Same as above	VT01b F-2614	Same as above	
4.	Signal Meter volume	1000kHz ANT Input 76dB 400Hz (MOD 30%) AM SSG	Same as above	Signal Meter	VR05 F-2614	4.3 on meter	

### Abbreviations

#### Equipment

AM FM Generator Oscilloscope..... Genescope  
 AM Standard Signal Generator ..... AM SSG  
 FM Standard Signal Generator ..... FM SSG  
 FM Stereo Generator..... Stereo SG  
 Oscilloscope ..... Scope  
 Audio Oscillator ..... Audio Osc.  
 Distortion Meter ..... Dist. Meter

#### Others

Clockwise ..... CW.  
 Counterclockwise ..... CCW.  
 Antenna ..... ANT.  
 Modulation..... MOD.

### 3. THREADING OF DIAL CORD

\*If a dial cord is cut off or slips, replace it by following procedures.

As this unit use 0.6mm $\phi$  cord, please replace it with the same type certainly.

\*The length of dial cord is approximately 160cm (65.3 inch)

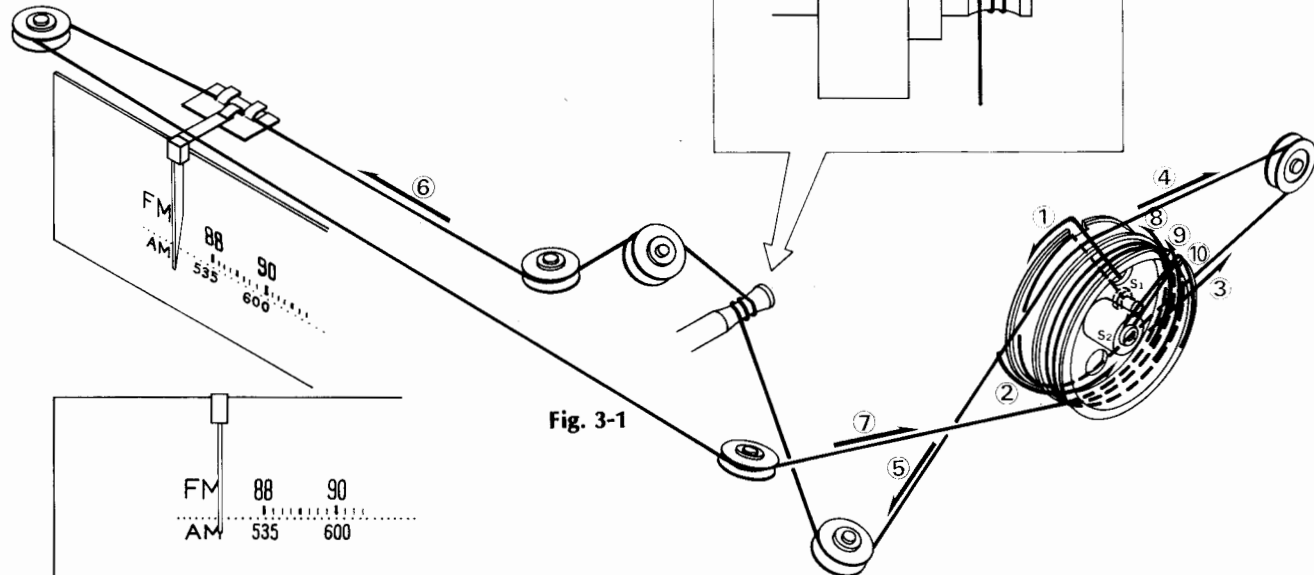

Fig. 3-1

Fig. 3-2

#### 3-1. Threading of Dial Cord

Thread the dial cord in numerical order from ① to ⑩ as Fig. 3-1.

- 1) Close the variable capacitor completely (Max. capacitance).
- 2) Tie dial cord to the screw, S1 of the dial pulley.
- 3) Thread cord in the direction of arrow from ① to ⑩.
- 4) After ⑩, tie the cord to the screw S2 of the dial pulley.

#### 3-2. Attachment of Dial Pointer

- 1) Close the variable capacitor completely.
- 2) Set the dial pointer to the position on dial scale as shown in Fig. 3-2.

\*Confirm that the dial pointer runs smoothly on the dial scale by turning the tuning shaft.

Stock No.	Description
6036051	Dial Cord (0.6mm $\phi$ )
6146670	D44 Type Pulley



# 4. PARTS LOCATION & PARTS LIST

\* Value and Stock No. of most Resistors and Capacitors are shown in Common Parts List attached.

## 4-1. F-2625 Power Supply Circuit Board (Mother Board) (Stock No. 7501691)

Conductor Side

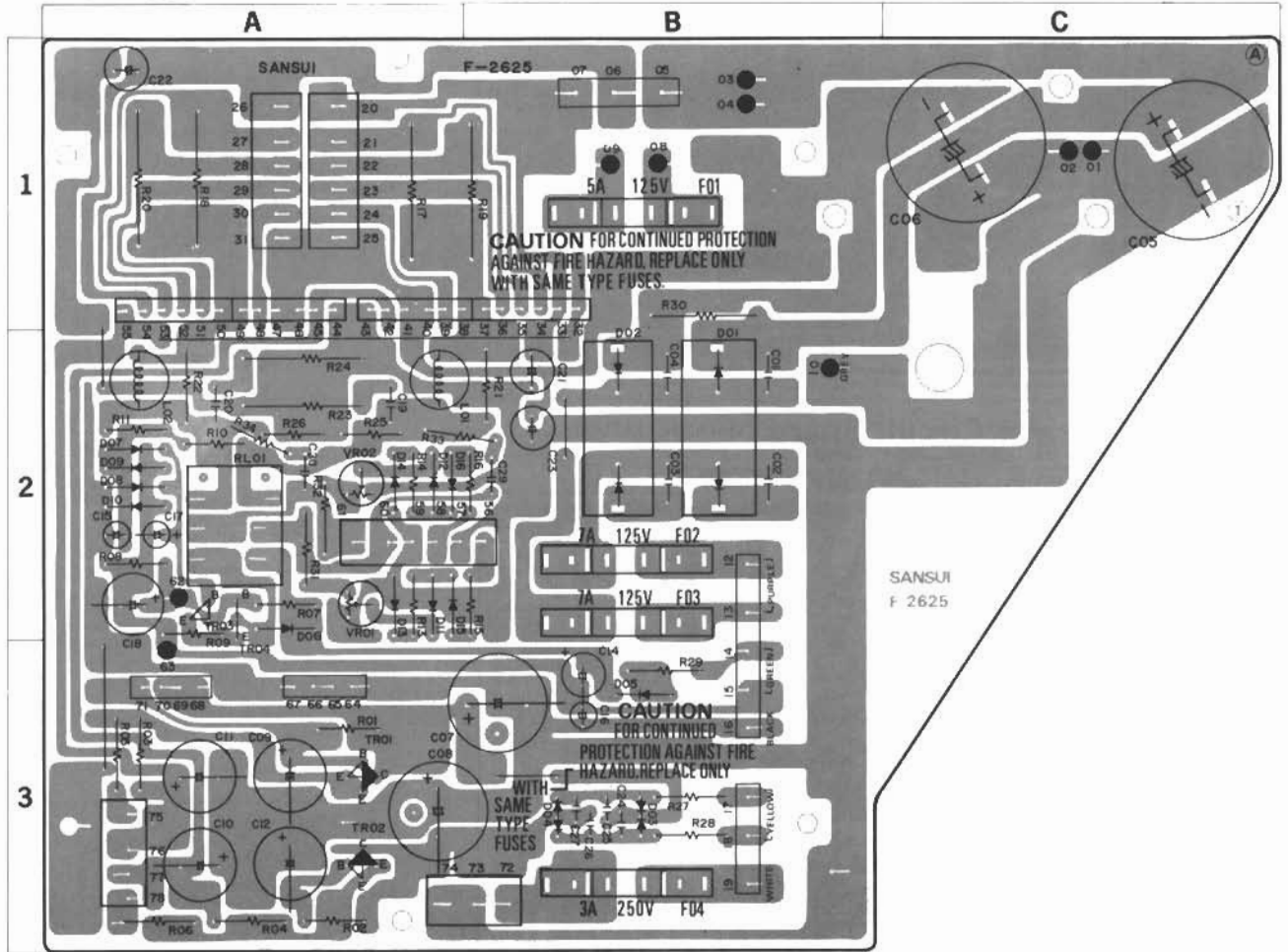

### Parts List

Parts No.	Stock No.	Description	Position	Parts No.	Stock No.	Description	Position	Parts No.	Stock No.	Description	Position		
TR01	0308520.1	2SD438 (D, E)	Transistor	D13, 14	0311160	152473D	Diode	R29	0192479	4.7Ω	1/2W Fuse R.		
TR02	0303360.1	2SE560 (D, E)		D15, 16	0310330.1	1N60		R30	0182822	8.2kΩ	2W Co.R.	1B	
TR03	0305951.2,3	25C945 (G, P, K)		2A	C01-04	0655103	10000pF 500V C.C.	2B	R31, 32	0210471	470Ω	1/2W M.R.	2A
TR04	0305953	25C945 (K)		2A	C05, 06	0559382	10000pF 50V E.C.	1C	R33, 34	0192479	4.7Ω	1/2W Fuse R.	2A, B, 2A
D01	031131A	SS-5	1A	C07	0549302	1000pF	3B	Lo1, 02	4290210	Filter Coil	2A		
D02	0311320	SS-5R	2B	C08	0549301	470pF	3A	XL01	1130370	Relay	2A		
D03	0310800	10DC2	3B	R04	0192101	100Ω	1/2W Fuse R.	VR01, 02	1035110	4.7kΩ (B)	2A		
D04	0310801	10DC2R	3B	R17, 18	0135338	0.33Ω	1A	F02, 03	0432500	7A 125V AC Fuse	2B		
D05	0310340	10D1 (152226)	3B	R19, 20	0135338	0.33Ω	5W Co.R.	F04	0432260	3A 250V AC Fuse	3B		
D06	0310340	10D1 (152226)	2A	R21, 22	0103479	4.7Ω	1/2W C.R.	2410720		4P Pin Ass'y Type A			
D07, 08	0310330.1	1N60	2A	R23, 24	0133479	4.7Ω	3W Co.R.	2410730		6P Pin Ass'y Type A			
D09, 10	0310330.1	1N60	2A	R27, 28	0192479	4.7Ω	1/2W Fuse R.	2410920		3P Pin Ass'y Type E			
D11, 12	0310330.1	1N60	2A					2410950		6P Pin Ass'y Type E			

## 4-2. F-2627 Illumination Circuit Board (Stock No. 7594141)

Conductor Side



### Parts List

Parts No.	Stock No.	Description
D01	0310340	10D1 Diode
C01	0511471	470pF 10V E.C.
R01	0191180	18Ω 1/2W Fuse R.

### 4-3. F-2626 Power Supply Circuit Board (Stock No. 7501701)

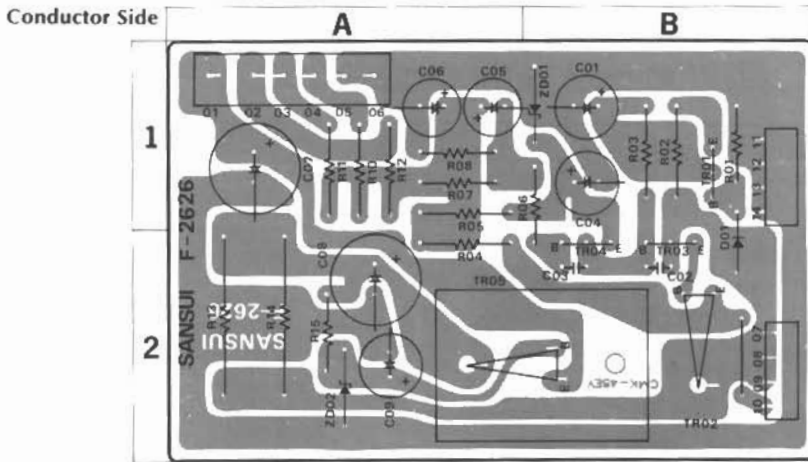

#### Parts List

Parts No.	Stock No.	Description	Position
TR01	0300310, 1	25A697 (C, D)	1 B
TR02	0308411, 2	75D314 (D, E)	2 B
TR03	0305930, 1	75C-1211 (C, D)	2 B
TR04	0305930, 1	75C-1211 (C, D)	2 B
TR05	0308551, 2, 3	25D315V10 (D, E, F)	2 A, B
D01	0340120	VD1212 Varistor	1, 2 B
ZD01	0315970	EQA01-13R	1 B
ZD02	0315970	EQA01-13R	2 A
R02	0210391	390Ω	1 B
R03	0210332	3.3kΩ	1 B
R04	0210220	22Ω	2 A
R05	0210472	4.7kΩ	1 A
R10	0210271	270Ω	1 A
R11	0210681	680Ω	1 A
R12	0210681	680Ω	1 A
R13	0183561	560Ω	2 A
R14	0183561	560Ω	2 A
	2410950	6P Type E Pin Ass'y	
	2420510	5P Type A Connector Ass'y	

### 4-4. F-2624 Driver Circuit Board (Stock No. 7571411)

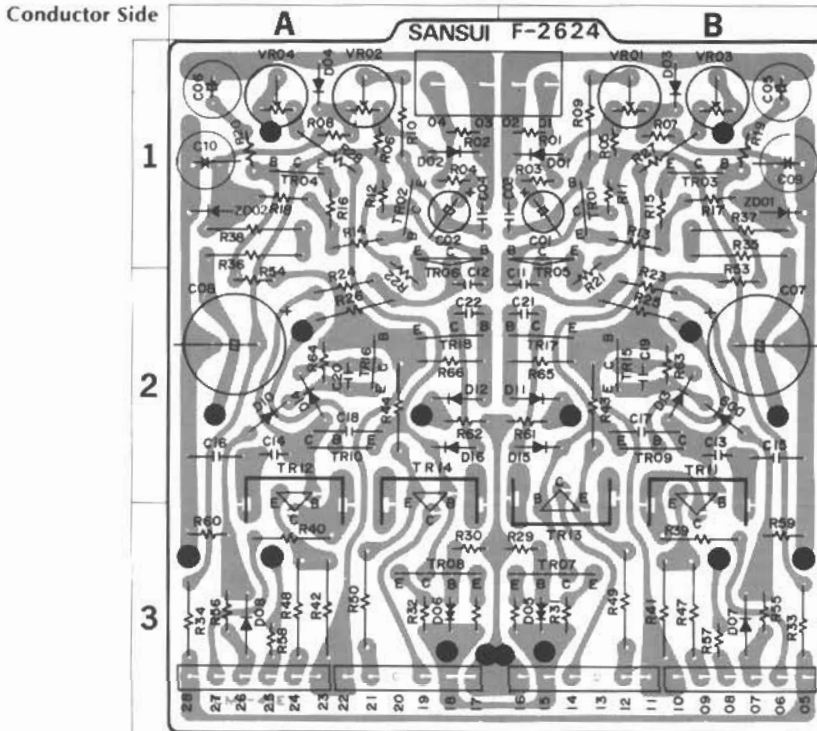

#### Parts List

Parts No.	Stock No.	Description	Position
TR01, 02	0306270, 1	25C1708 (F, G)	1 B, 1 A
TR03, 04	0306270, 1	25C1708 (F, G)	1 B, 1 A
TR05, 06	0300790, 1	25A899 (G, B)	1 B, 1 A
TR07, 08	0306400, 1	25C1904 (G, B)	3 B, 3 A
TR09, 10	0305871, 2	25C984 (B, C)	3 B, 3 A
TR11, 12	0308431, 2	25D381 (M, L)	2, 3 B, 2, 3 A
TR13, 14	0303260, 1	(N, M)	2, 3 B, 2, 3 A
TR15, 16	0305951, 2	25C945 (Q, P)	2 B, 2 A
TR17, 18	0300510, 1	25A733 (P, Q)	2 B, 2 A
D01, 02	0311160	152473D	1, 2 B, 1 A
	0311180	151588	
D03, 04	0311160	152473D	1 B, 1 A
	0311180	151588	
D05, 06	0340120	VD1212	3 B, 3 A
D07, 08	0311160	152473D	3 B, 3 A
	0311180	151588	
D09, 10	0311160	152473D	2 B, 2 A
	0311180	151588	
D11, 12	0311160	152473D	2 B, 2 A
	0311180	151588	
D13, 14	0311160	152473D	2 B, 2 A
	0311180	151588	
D15, 16	0311160	152473D	2 B, 2 A
	0311180	151588	
ZD01, 02	0316070	EQA01-24R	1 B, 1 A
R33, 34	0191181	180Ω	3 B, 3 A
R35, 36	0191479	4.7kΩ	1 B, 1 A
R37, 38	0210392	3.9kΩ	1 B, 1 A
R39, 40	0192100	10Ω	3 B, 3 A
R41, 42	0192151	150Ω	3 B, 3 A
R43, 44	0192151	150Ω	2 B, 2 A
R47, 48	0192479	4.7kΩ	3 B, 3 A
R49, 50	0192479	4.7kΩ	3 B, 3 A
VR01, 02	1035350	4.7kΩ (B)	1 B, 1 A
VR03, 04	1035310	1kΩ (B)	1 B, 1 A
	2410930	4P Type E Pin Ass'y	
	2420520	6P Type A Connector Ass'y	

### 4-5. F-2623 Filter Circuit Board (Stock No. 7594131)

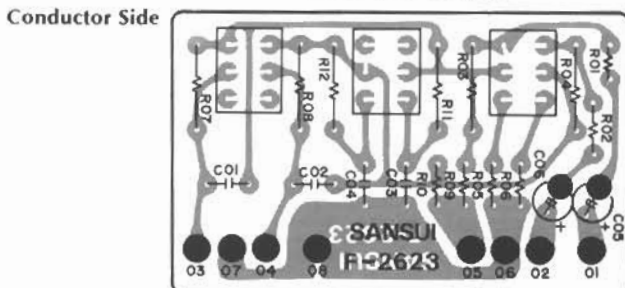

#### Parts List

Parts No.	Stock No.	Description
S01	1131270	Push Switch

4-6. F-2620 Equalizer & Mic Circuit Board (Stock No. 7550951)

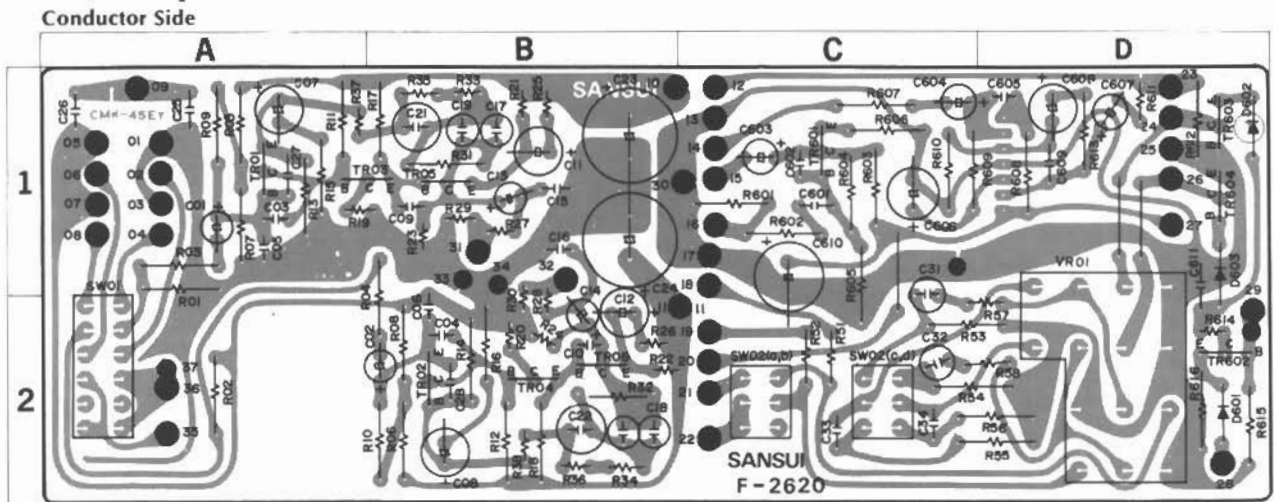

Parts List

Parts No.	Stock No.	Description	Position	Parts No.	Stock No.	Description	Position	Parts No.	Stock No.	Description	Position	
TR01, 02	0306070	25C1313 F, G	1 A, 2 B	D002	0311160	152473D	1 D	R31, 32	0231563	664 Ω	1 B, 2 B	
TR03, 04	0300470	25A726 (W) F, G	1 A, B, 2 B		0311180	151588	Diode	R33, 36	0231684	680k Ω	1 B, 2 B	
TR05, 06	0300470	25A726 (W) F, G	1 B, 2 B	D003	0311160	152473D		1, 2 D	VR01	1060320, 1	250k Ω M.N.B × 2	2 D
TR001	0306070	25C1313 F, G	1 C		0311180	151588			S01	1131250	Push Switch	7 A
TR002	0300470	25A726 (W) F, G	2 D	C01, 02	0573339	3.3 μF 35V T.C.	1 A, 2 B	S02	1131260	Push Switch	7 C	
TR003, 004	0306390	25C1636-1, -2	1 D	C17, 18	0625102	1000 pF	1 B, 2 B					
IC401	0360190	8A312 IC		C19, 20	0620361	360 pF	1 B					
D001	0311160	152473D	2 D	C21, 22	0625472	4700 pF	1 B, 2 B					
	0311180	151588		C31, 32	0620331	330 pF	2 C					

4-7. F-2615 FM Muting Circuit Board (Stock No. 7521311)

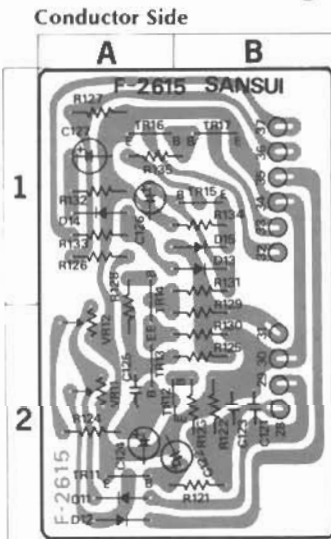

Parts List

Parts No.	Stock No.	Description	Position	Parts No.	Stock No.	Description	Position
TR11	0305731, 2	25C711 (E, F)	2 A	D12	0311160	152473D	2 A
	0305951, 2	25C945 (Q, P)			0311180	151588	
TR12	0305731, 2	25C711 (E, F)	2 A	D13	0311160	152473D	1 B
	0305951, 2	25C945 (Q, P)			0311180	151588	
TR13	0305731, 2	25C711 (E, F)	2 A	D14	0311160	152473D	1 A
	0305951, 2	25C945 (Q, P)			0311180	151588	
TR14	0305731, 2	25C711 (E, F)	1, 2 A	D15	0311160	152473D	1 B
	0305951, 2	25C945 (Q, P)			0311180	151588	
TR15	0300510	25A733 (P, Q)	1 B	VR11	1035410	47k Ω (B)	2 A
TR16	0306390	25C1636-1	1 A	VR12	1035430	100k Ω (B)	2 A
TR17	0306390	25C1636-1	1 B		2420510	4P Type A Connector Ass'y	
					2420520	6P Type A Connector Ass'y	
D11	0311160	152473D	2 A				
	0311180	151588					

4-8. F-2621 Accessory Switch Circuit Board (Stock No. 7594121)

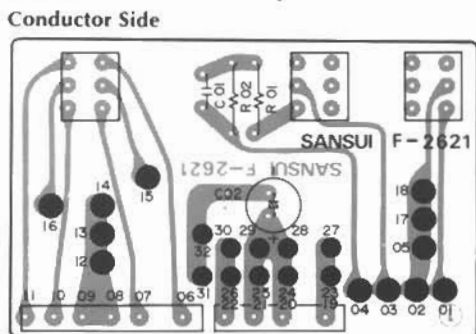

Parts List

Parts No.	Stock No.	Description
S01	1131280	Push Switch
	2410930	4P Pin Ass'y Type E
	2410950	6P Pin Ass'y Type E

### 4-9. F-2614 Tuner Circuit Board (Stock No. 7521301)

Conductor Side

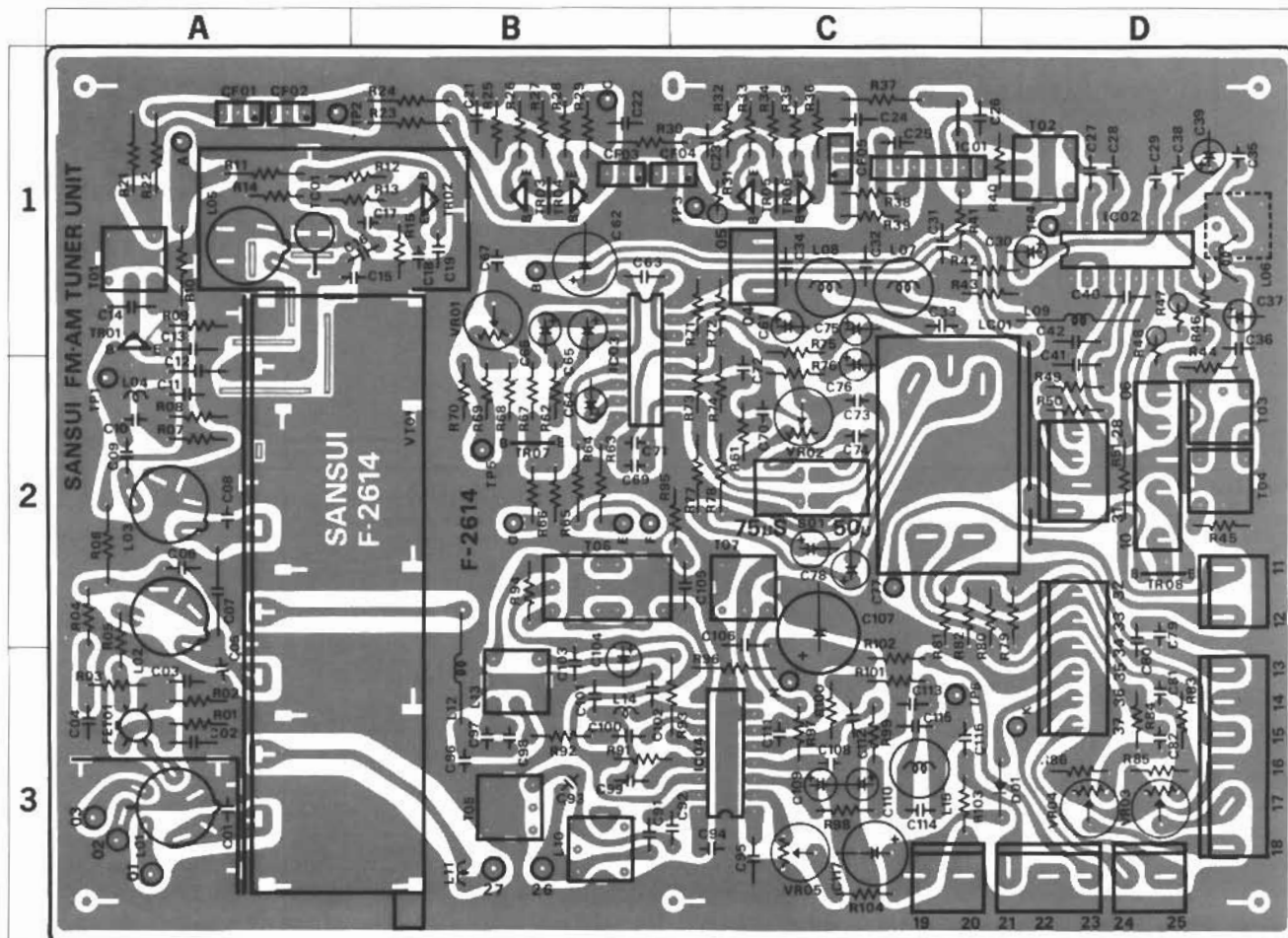

#### Parts List

Parts No.	Stock No.	Description	Position	Parts No.	Stock No.	Description	Position	Parts No.	Stock No.	Description	Position
TR01	0305801.2	2SC1047 (B)	1A	C67	0629005	360 pF	1B	T02	4230620	IC Coil	2C
TR02	0305801.2	2SC1047 (B, C)	1B	C73	0620561	560 pF	2C	CF01	0910150	Ceramic Filter	1A
TR03	0306341.2	2SC1674 (L, K)	1B	C74	0620561	560 pF	2C	CF02	0910150		1A
TR04	0306341.2	2SC1674 (L, K)	1B	C97	0669400	15 pF	3B	CF03	0910150		1B
TR05	0306341.2	2SC1674 (L, K)	1C	C98	0620361	360 pF	3B	CF04	0910150		1B, C
TR06	0306341.2	2SC1674 (L, K)	1C	L01	4200720	Antenna Coil	3A	CF05	0910150		1C
TR07	0305731.2	2SC711 (E, F)	2B	L02	4210340	RF Coil	2A	LC01	0910360	Low Pass Filter	2C, D
TR08	0305951.2	2SC945 (Q, P)	2D	L03	4210340	RF Coil	2A	VR01	1034250	100kΩ (B)	1B
	0300221	2SA562 (Y)		L04	4900140	Inductor	2A	VR02	1035190	4.7kΩ (B)	2C
	0300311	2SA697 (D)		L05	4220400	OSC Coil	1A	VR03	1035110	4.7kΩ (B)	3C
IC01	0360120	IC μPC55H	1C	L06	4290280	Inductor	1D	S01	1110270	Slide Switch	2C
IC02	0360350	IC HA1137W	1D	L07	4900250	Inductor	1C	VT01	1220260	Variable Capacitor	2, 3 A, B
IC03	0360320	IC HA1196	1, 2 B	L08	4900240	Inductor	1C	TC01	1230090	Trimmer Capacitor	1A
IC04	0360390	IC HA1197	3C	L09	4290011	Choke Coil	1D		2410570	5P Type D Pin Ass'y	
FT01	0370121.2	3SK41 (L) FET	3A	L11	4900100	Inductor	3B		2410650	5P Type D Pin Ass'y	
C01	0669325	15 pF	3A	L12	4290011	Choke Coil	2, 3 B		2410850	4P Type B Pin Ass'y	
C05	0669325	15 pF	3A	L13	4220650	OSC Coil	3B		2410860	6P Type B Pin Ass'y	
C08	0669325	15 pF	2A	L14	4900110	Inductor	3B		2410910	2P Type E Pin Ass'y	
C12	0679008	1 pF	50V G.C.	L15	4900220	Inductor	3C		2410920	3P Type E Pin Ass'y	
C15	0669330	20 pF	1A, B	T01	4235930	IC Coil	1A		2410950	6P Type E Pin Ass'y	
C16	0669295	10 pF	1A, B	T02	4235930		1D				
C17	0669295	10 pF	50V C.C.	T03	4235990, 1		2D				
C18	0669295	10 pF	1B	T04	4234000, 1		2D				
C35	0669204	3.3 pF	1D	T06	0910280	Ceramic Filter	2B				

### 4-10. F-2622 Tone Control Circuit Board (Stock No. 7561481)

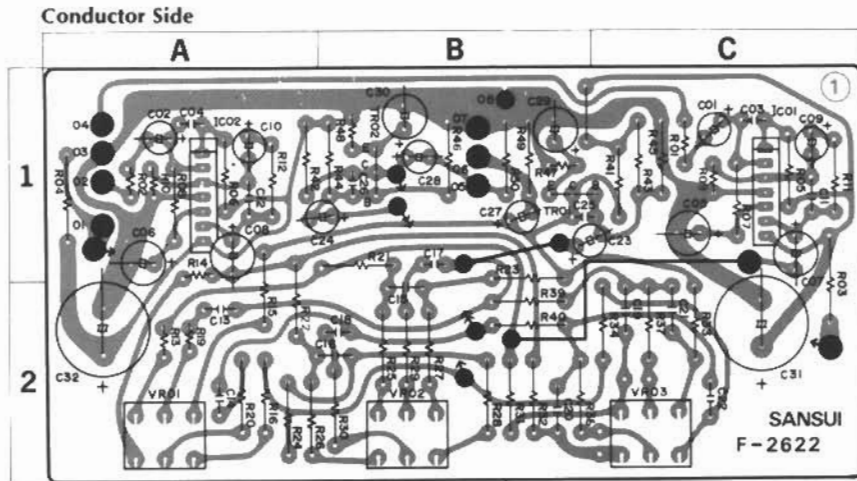

#### Parts List

Parts No.	Stock No.	Description	Position	
TR01, 02	0306070, 1	25C1313 (F.G) Transistor	1 B	
IC01, 02	0360190	BA312 IC	1 C, 1 A	
R03, 04	0210821	820Ω 1/2W M.R.	1, 2 C, 1 A	
VR01	1015180, 1	100kΩ (8×2)	Tone Control Volume	
VR02	1015180, 1	100kΩ (8×2)		2 A
VR03	1015180, 1	100kΩ (8×2)		2 B
			2 C	

### 4-11. Figures

#### Connector & Pin Ass'y

##### Connector

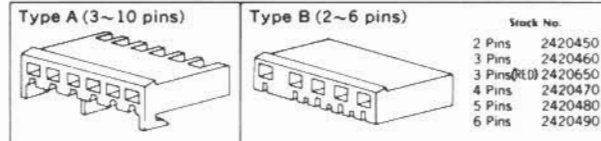

NOTE: Since stock number of female connectors (type B) with wires are not shown in each parts list of Complete circuit board, please refer to the above parts list when ordering the connector.

##### Pin Ass'y

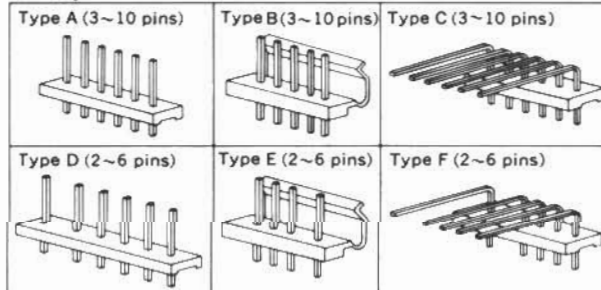

#### —Abbreviations—

<b>C.R.</b> : Carbon Resistor	<b>BP.E.C.:</b> Bi-Polar Electrolytic Capacitor
<b>S.R.</b> : Solid Resistor	<b>C.C.</b> : Ceramic Capacitor
<b>Ce.R.</b> : Cement Resistor	<b>Mi.C.</b> : Mica Capacitor
<b>M.R.</b> : Metallized Film Resistor	<b>O.C.</b> : Oil Capacitor
<b>M.C.</b> : Mylar Capacitor	<b>P.C.</b> : Polystyrene Capacitor
<b>E.C.</b> : Electrolytic Capacitor	<b>E.C.</b> : Tantalum Capacitor

## 5. OPERATION BLOCK DIAGRAM

### 5-1. Power AMP. & Protector Section Block Diagram

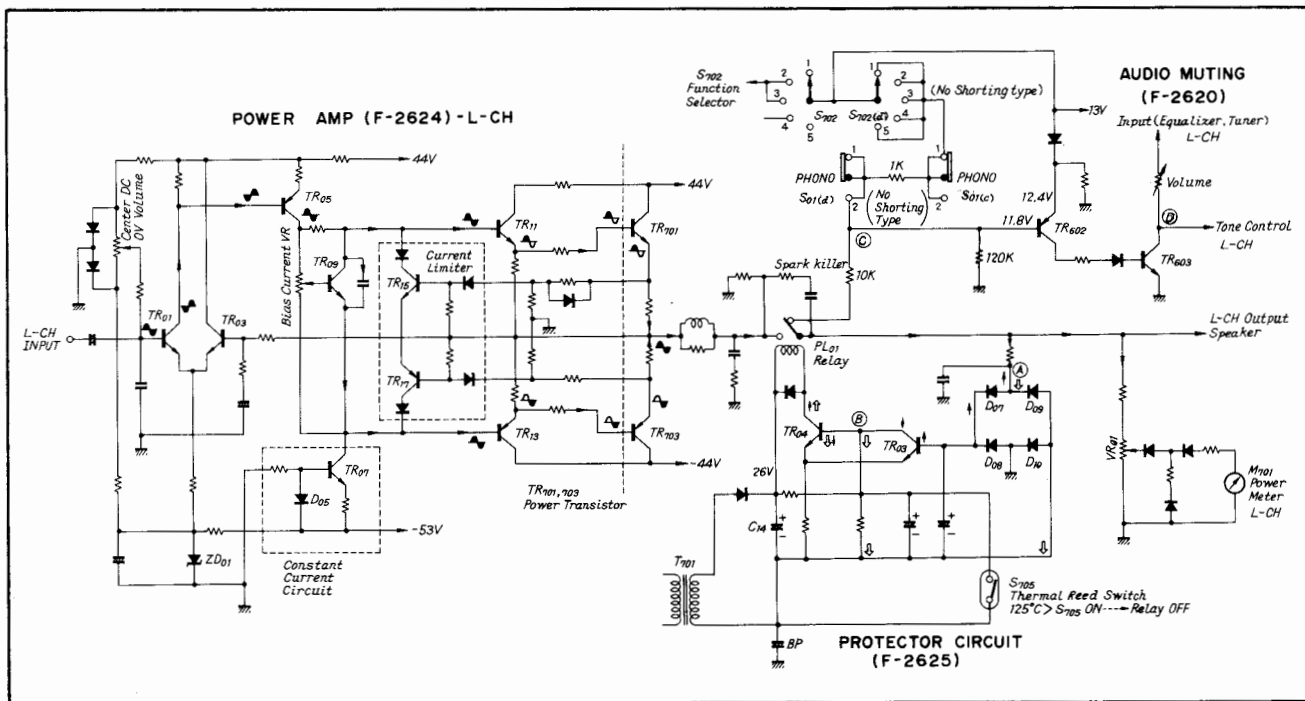

#### ※ Operations of Protector Circuit and Audio Muting Circuit

1. Speaker Protector Circuit sensing abnormal DC voltage level at speaker terminals.
  - (1) When exceeding over DC +2.5V at point A
    1. TR03 turns on through D07 and TR04 off.
    2. By TR04 off, Relay RL01 turns off.
    3. By the Relay RL01 off, it disconnects speaker terminals from power amplifier output.
  - (2) When appearing lower DC -2.5V at point A
    1. Voltage level at point B drops down through D09 and TR04 turns off.
    2. As same as above steps 1-2 and 1-3.
2. Protector Circuit against thermal run-away in power transistor
  1. When rising over 125°C on the surface of heat-sink, thermal reed switch S705 turns on automatically.
  2. By the switch S705 on, voltage level at point B drops down and TR04 becomes off.
  3. By TR04 off, Relay RL01 becomes off, resulting in the relay being released, namely it separates between speakers and power amplifier output.
  4. When temperature on the surface of heatsink reduces in a certain degrees, the switch S705 turns on.
  5. By the Relay on, it connects again speaker terminals from power amplifier output.
3. Audio Muting Circuit
  - (1) This circuit is used to cut click noise caused by switching SELECTOR or PHONO push button.
    1. When switching S702 (d) or S01 (d) (c), voltage level at point C drops down due to non-shorting switch.
    2. By the voltage-drop at point C, TR602 and TR603 turn on.
    3. By TR603 on, voltage level at point D drops down, then tone control circuit and Power Amplifier Stage do not operate completely.
  - (2) This circuit is also used to cut pop noise through Spark killer caused by turning on the power switch.
    1. When turning on the power switch, the Relay RL01 remains off for a few seconds.
    2. Voltage level at point C drops down through speakers, the Relay and resistor 10 kohms.
    3. TR602 and TR603 turn on, then voltage level at point D drops down.
    4. By voltage-drop at point D, Tone Control Circuit and power amplifier stage do not operate completely.
    5. When the Relay turns on, by delay-operation of relay circuit with R C time constant, voltage levels at point C and D increase, then these circuits begins to operate completely.

## 5-2. Tuner Section Block Diagram

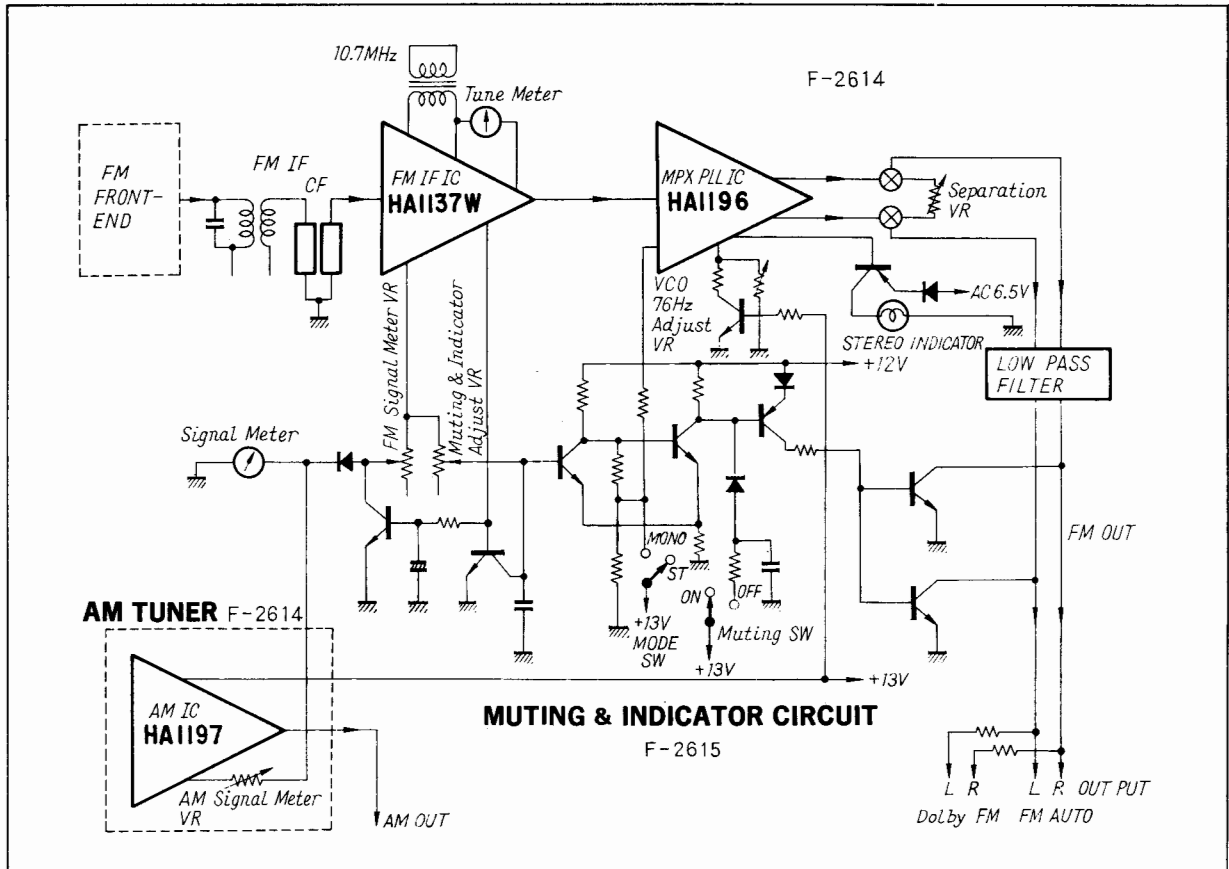

## 5-3. PLL Block Diagram (IC HA1196)

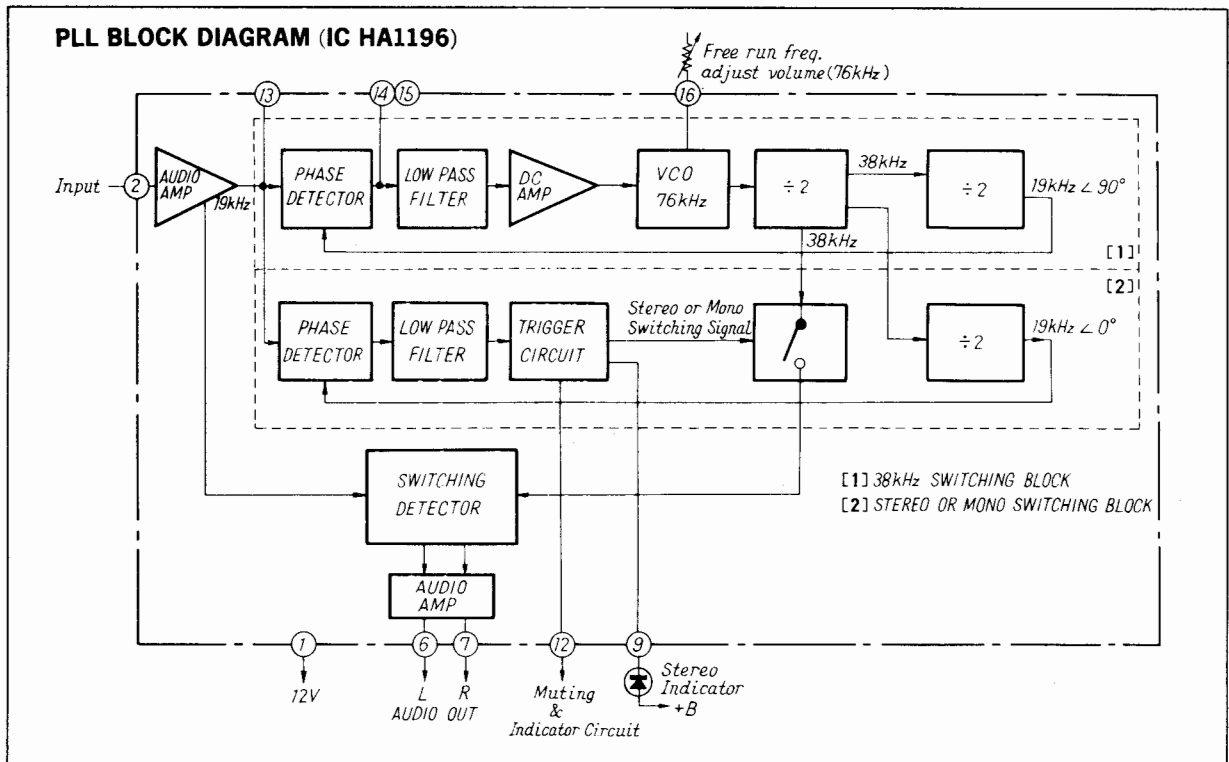

## 5-4. FM IF System Block Diagram (IC HA1137W)

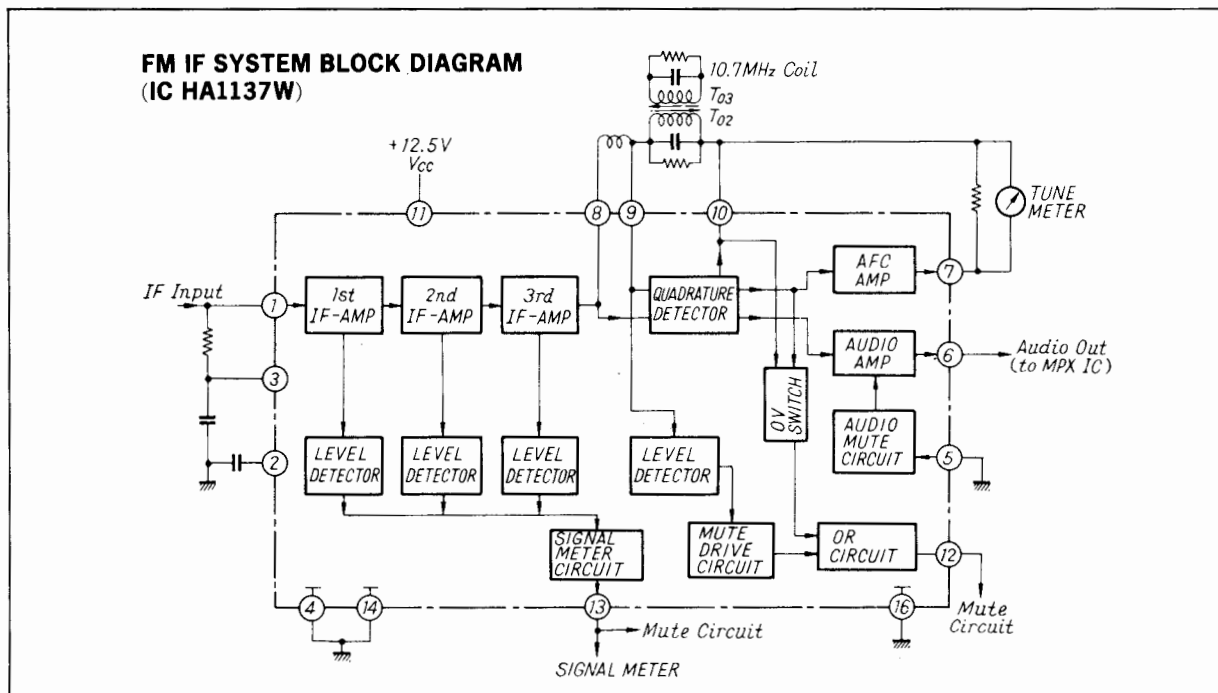

### ※ Functions (IC HA1137W)

This IC has operating functions of various circuits as listed below.

- 1) IF AMP.
- 2) Quadrature detection.
- 3) Low-Noise audio Preamp.
- 4) Delayed AGC detector and driver for Front-end.
- 5) Signal meter circuit.
- 6) Center meter circuit.
- 7) Muting (operation to input signal strength).
- 8) Muting (operation at detuning).
- 9) Multipass circuit.

### ※ Main features (IC HA1137W)

1. This IC includes all functions required in FM IF stage.
2. As indicated above, this IC has functions of Muting circuit which operates below a certain input signal level. And also the IC includes new muting circuit, namely it has 0 volt switch which operates the muting circuit when the difference (absolute value) of detector output voltage between Tuning-ON and Detuning exceeds a certain voltage, utilizing S-curve characteristics of FM detector. By this advantage, it is possible to eliminate or avoid "Pop noise" caused by variation of the DC voltage at tuning-OFF.
3. The IC makes it possible to produce high-quality tuner having better selectivity and sensitivity by connecting 6-element filters between Front-end and the IC, as it has higher gain and better suppression ratio in amplitude modulation.
4. Linear swing of signal meter is obtained.

### ※ Main features of PLL (IC HA1196)

In the multiplex demodulation circuit, because of sub-carrier wave (38kHz) being required for demodulation, the pilot signal (19kHz) sent from FM stereo broadcasting station is being made while doubling.

It is necessary for this sub-carrier wave that its phase confirms to that of pilot signal correctly, and if there is any phase difference between them, FM stereo separation becomes poor.

In the conventional products, LC resonance circuit has been used so far for the circuit of this section, on the other hand, in model 7070, IC in PLL is used, which prevents FM stereo separation from becoming poor due to deviation in resonance frequency or phase to temperature change and, in result, ensures stereo separation of more than 50dB at 1kHz.

### Advantages

- 1) Selectivity is superior.
- 2) Phase characteristics is good.
- 3) It is virtually not affected by temperature.
- 4) No secular change occurs.



# 6. SCHEMATIC DIAGRAM

## (1) BLOCK DIAGRAM

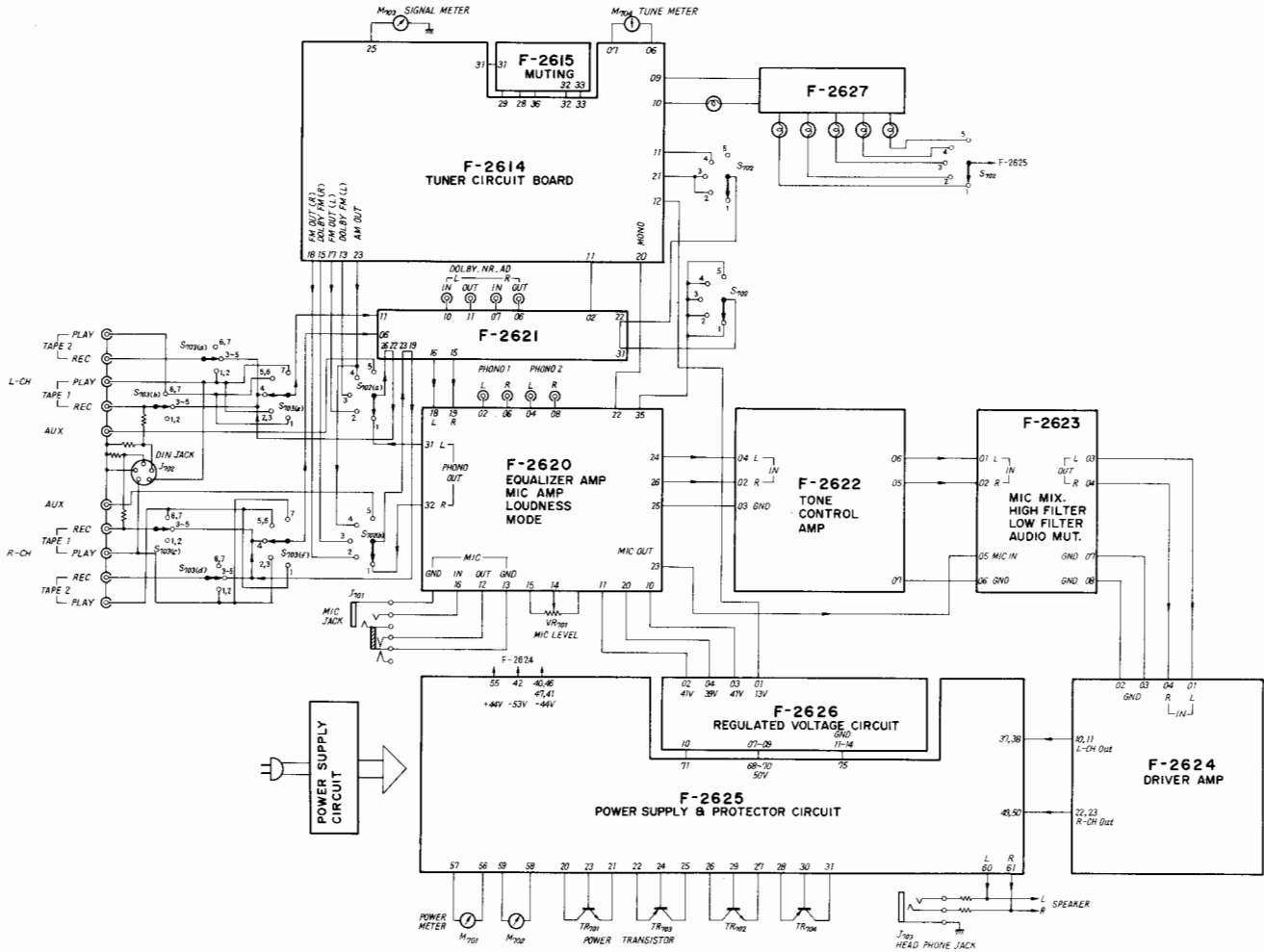

### Semiconductors

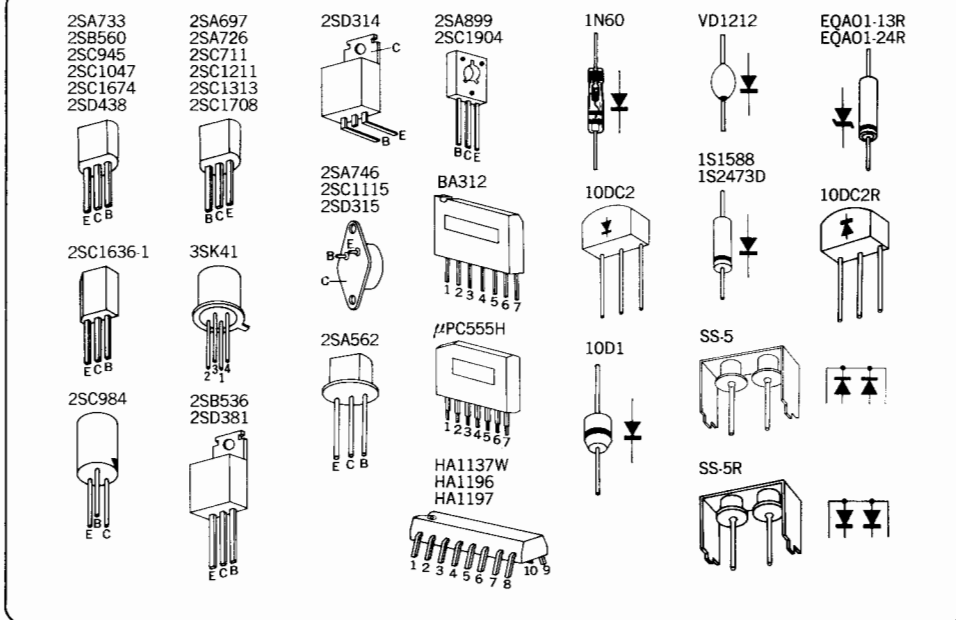

# (2) TUNER SECTION

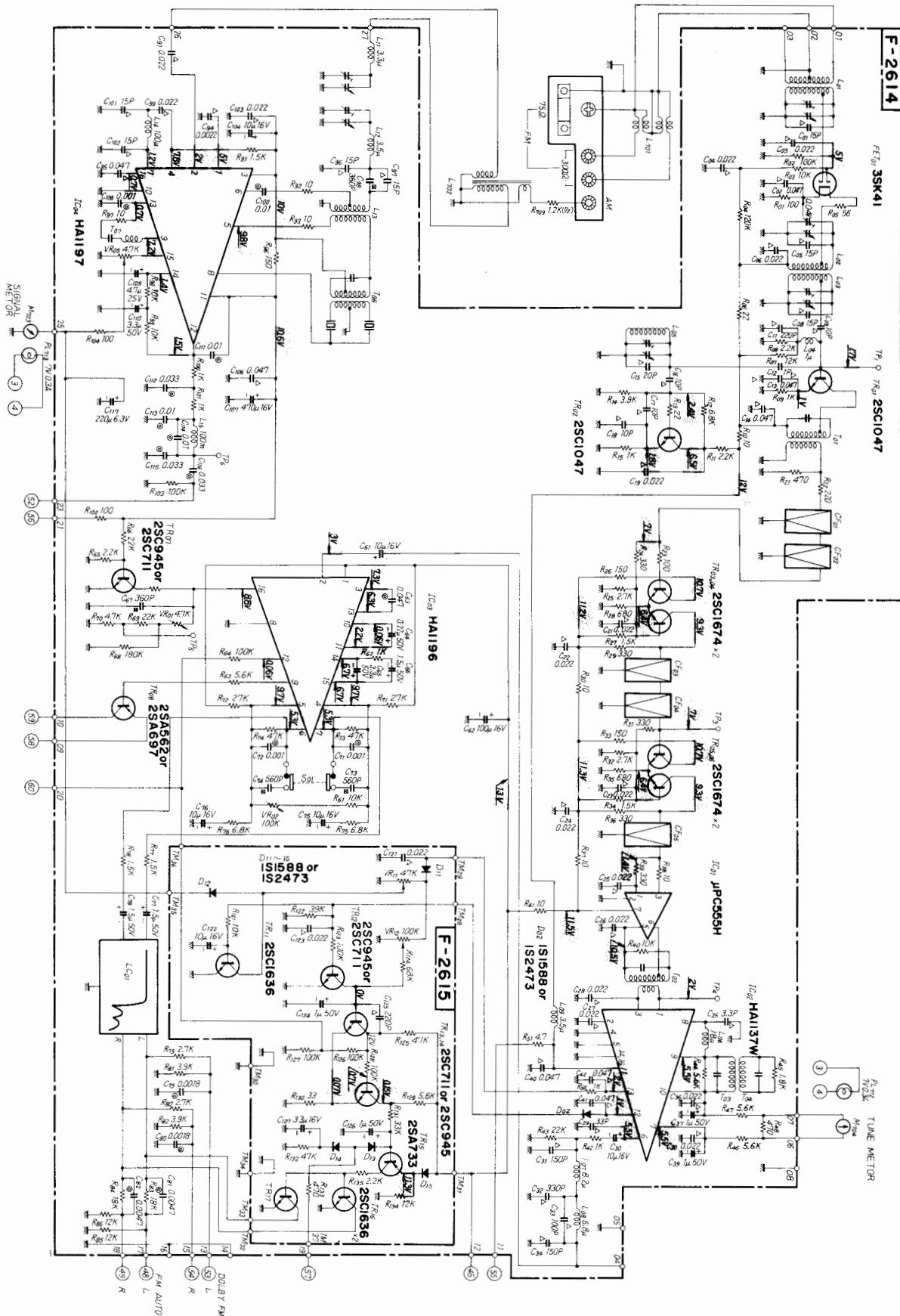



• La présentation et les spécifications sont susceptibles d'être modifiées sans préavis par suites d'améliorations éventuelles.  
 • Änderungen, die dem technischen Fortschritt dienen, bleiben vorbehalten.  
 • Design and specifications subject to change without notice for improvement.

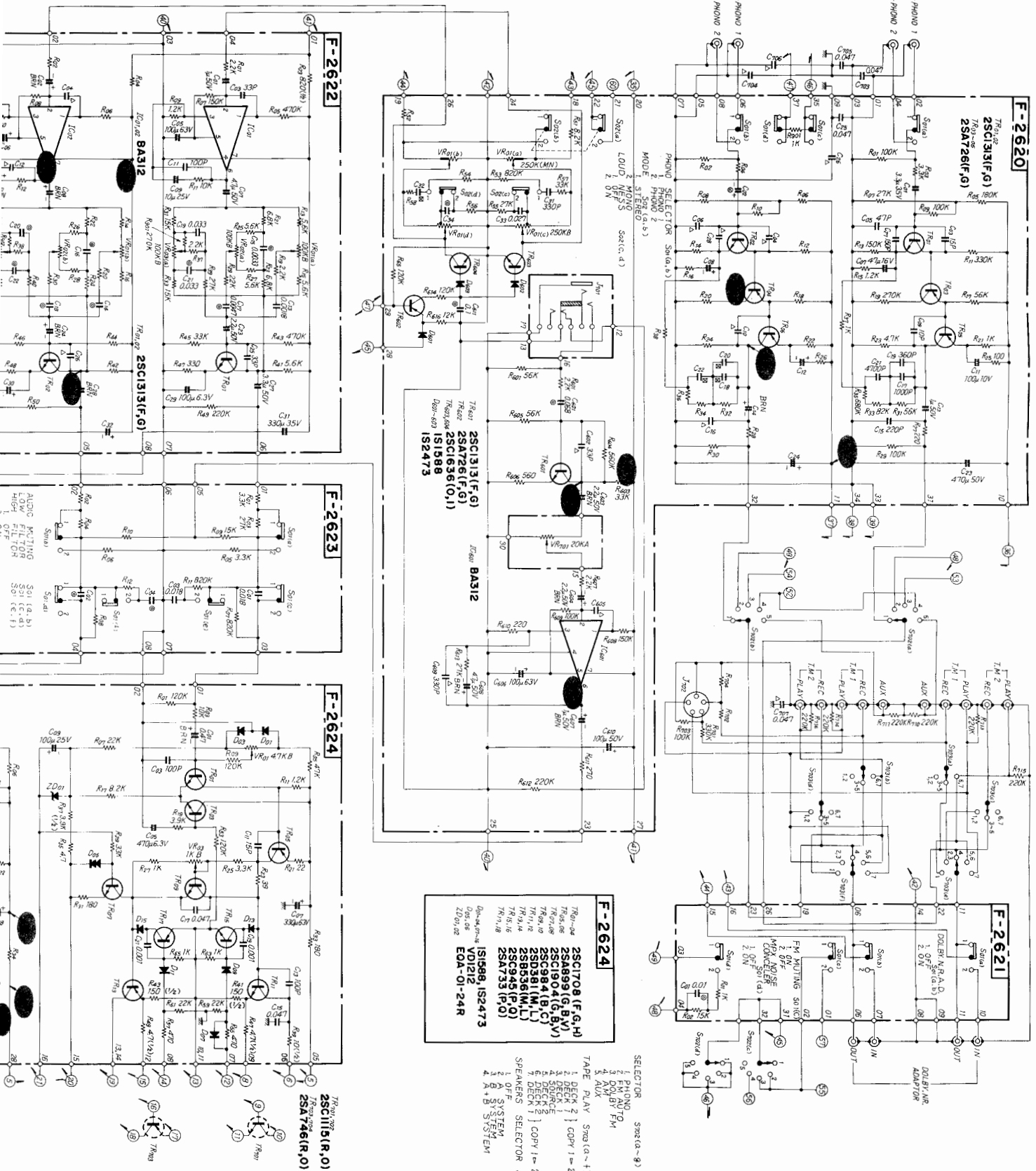

## 7. OTHER PARTS

### 7-1. Top Side

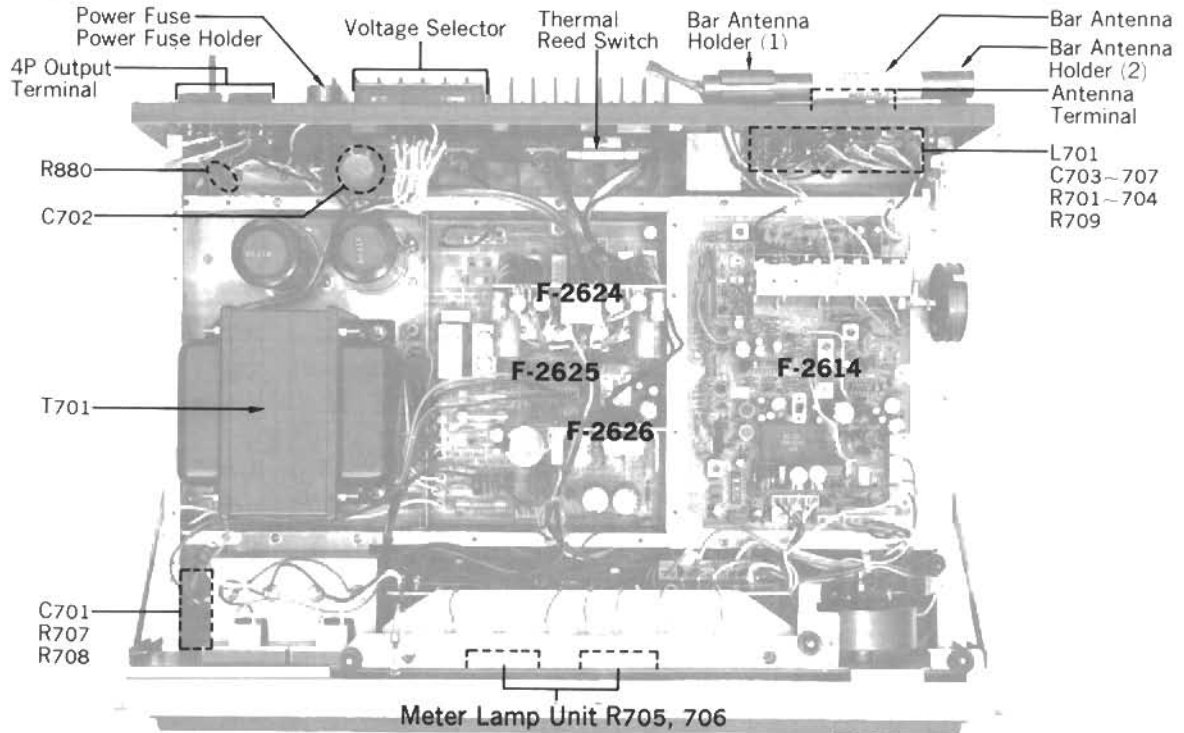

### 7-2. Bottom Side

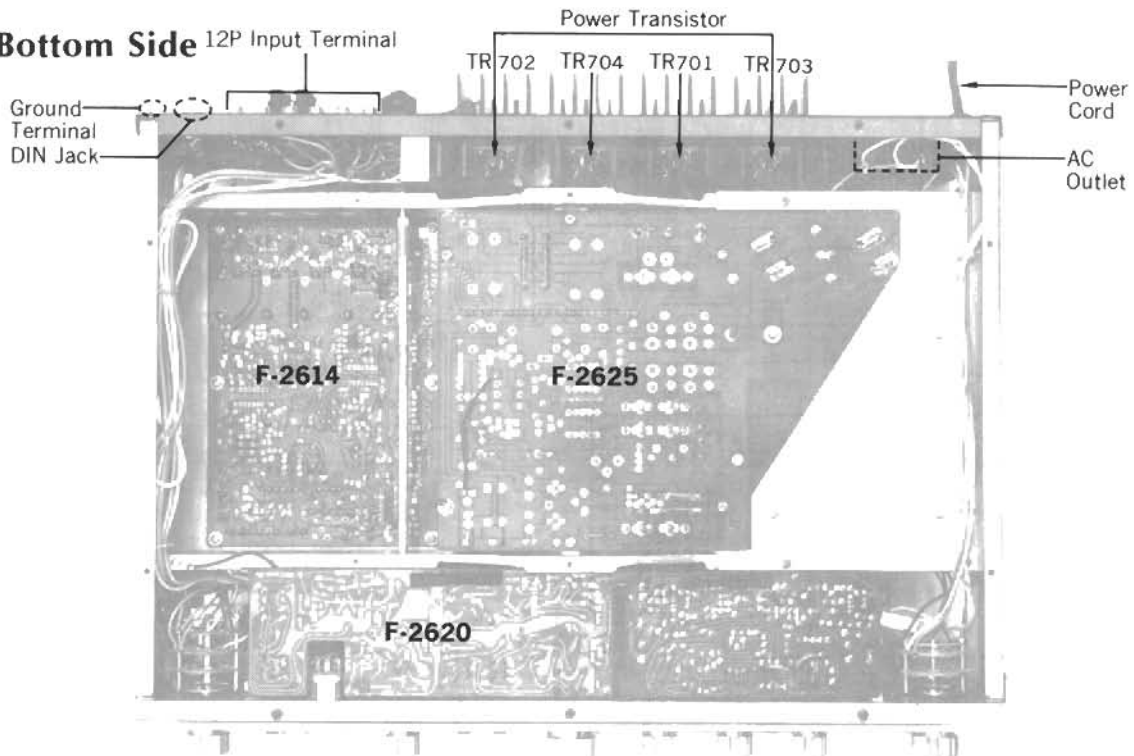

# 7-3. Exploded View

- 1 ~ 24
- 25 ~ 50

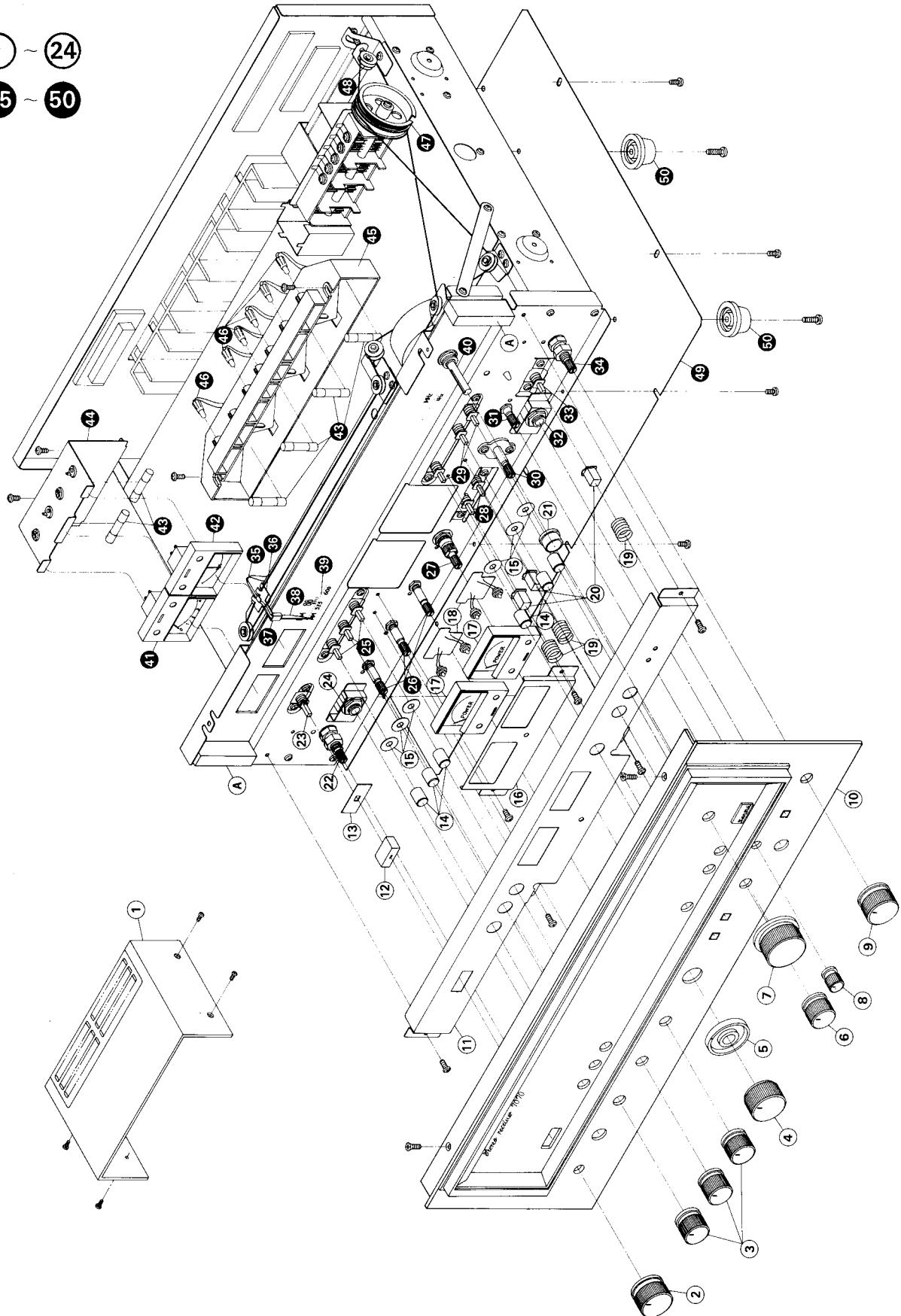

**Parts List (Top Side & Bottom Side)**

Parts No.	Stock No.	Description
TR701	0306230, 1	2SC1115 (R, O)
TR702	0306230, 1	2SC1115 (R, O)
TR703	0300870, 1	2SA746 (R, O)
TR704	0300870, 1	2SA746 (R, O)
		} Power Transistor
C701	0605337	0.033 $\mu$ F 250V M.C.
C702	0659802	0.0047 $\mu$ F 150V C.C.
C703-707	0657473	47000pF 50V C.C.
R701, 702	0107104	100k $\Omega$ $\frac{1}{4}$ W C.R.
R703, 704	0107334	330k $\Omega$ $\frac{1}{4}$ W C.R.
R705, 706	0191100	10 $\Omega$ $\frac{1}{4}$ W Fuse R.
R707, 708	0163221	220 $\Omega$ 3W Ce. R.
R709	0103122	1.2k $\Omega$ $\frac{1}{2}$ W C.R.
R880	0114335	3.3M $\Omega$ $\frac{1}{2}$ W S.R.
T701	4002450	Power Transformer
L701	4290021	Antenna Transformer, 75 $\Omega$ /300 $\Omega$
L702	4200830, 1	Bar Antenna
	5286450	Bar Antenna Holder (1)
	5286480	Bar Antenna Holder (2)
C701, 702	2450060	AC Outlet
J702	2430041	DIN Jack
F701	0432260	3A 250V (230/240V)
	0432290	5A 125V (100/125V)
	2300060	Fuse Holder, Power Fuse
	3800010	Power Cord
	2210310	Antenna Terminal
	2290160	4P Output Terminal
	2200470	12P Input Terminal
	2230150	Ground Terminal
	2410830	Voltage Selector Socket
	2410091	Voltage Selector Plug
	5268600	Voltage Selector Cover
	7726040	Meter Lamp Unit
S705	1900020	Thermal Reed Switch

**Parts List (Exploded View)**

Parts No.	Stock No.	Description
1	5727000	Bonnet
2	5318380	M-7 Type Knob, Speaker Switch
3	5318410	S-10 Type Knob, Tone Control
4	5318440	WI-6 Type Knob, Volume
5	5318431	WO-8 Type Knob, Balance Volume
6	5318410	S-10 Type Knob, Tape Play Switch
7	5318420	T-12 Type Knob, Tuning
8	5318340	Knob, MIC Level
9	5318380	M-7 Type Knob, Selector
10	7007350	Front Panel Ass'y
	5047940	Smoked Plate
	5286721	Knob, Guide
	5304780	Panel Window
	5336500	Sansui Mark
	5304790	Front Panel
11	5288010	Front Bracket
12	5326570	Knob, Power Switch
13	5047470	Masking Sheet, Power Switch
14	5326550	Knob, Push Switch
15	5186330	Masking Sheet, Push Switch
16	5287970	Meter Holder (A)
17	4300920	Power Meter
18	7726040	Power Meter Circuit Board
19	6906480	Spring
20	5326530	Knob, Push Switch
21	5396300	Masking Ring
22	1102700, 1	Speakers Switch
23	1131190	Power Switch
24	2430190	Head Phone Jack
25	1131270	Push Switch
26	1015180, 1	Tone Control Volume, 100k $\Omega$ B $\times$ 2
27	1060320, 1	Volume/Balance Volume, 250k M.N., 250k $\Omega$ B $\times$ 2
28	1131260	Lever Switch
29	1131280	Push Switch
30	1102710, 1	Tape Play Switch
31	1005170, 1	MIC Level Volume, 20k $\Omega$
32	2430170	MIC Jack
33	1131250	Phono Switch
34	1103560, 1	Function Switch
35	0400200	Dial Pointer Lamp, 6.3V 75mA
36	5516030	Teflon Sheet
37	5416350	Holder, Dial Pointer
38	5416050	Dial Pointer
39	5408080	Dial Glass
40	7036481	Tuning Unit Ass'y
41	4300740	Signal Meter
42	4300750	Tune Meter
43	0420040	Lamp, 7V 320mA
44	5287980	Meter Holder (B)
45	5066211	Illumination Box
46	0400450	Stereo Indicator Lamp, 7V 100mV
47	6146670	Dial Pulley, D44
48	7136082	Tension Unit
49	5058640	Bottom Plate
50	5516821	Leg
(A)	5047930	Shadow Packing

---

## 8. PACKING LIST

Parts No.	Stock No.	Description
1	9116680	Vinyl Cover
2	9027990	Stylofoam Packing
3	9027990	Stylofoam Packing
4	9009210	Carton Case
5	5996080	Curl Stopper

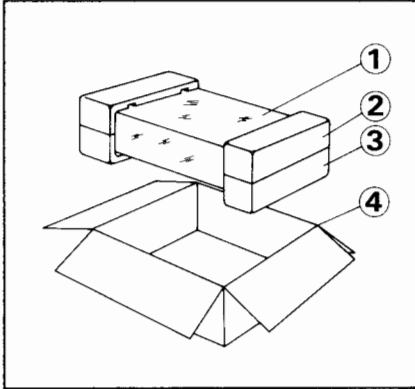

## 9. ACCESSORY PARTS LIST

Stock No.	Description
9209840	Operating Instructions
9237380	Schematic Diagram
2410560	Short Pin Plug



SANSUI ELECTRIC CO., LTD.  
14-1, 2-chome, Izumi, Suginamiku, Tokyo 168, Japan.  
TELEPHONE: (03) 323-1111 / TELEX: 232-2076