

Quadro

Brown goods TV SETS

MODEL: CTV-55SF50 TXT



TABLE OF CONTENTS

SAFETY INSTRUCTIONS AND MAINTENANCE	1
X-RAY RADIATION PRECAUTION	1
SAFETY PRECAUTION	1
PRODUCT SAFETY NOTICE	2
SAFETY SYMBOL DESCRIPTION	3
MAINTENANCE	3

ADJUSTMENTS	4
SET-UP ADJUSTMENTS	4
CIRCUIT ADJUSTMENTS.....	7

STRUCTURE AND CHASSIS FUNCTION DESCRIPTION.....	13
STRUCTURE BLOCK DIAGRAM	13
CHASSIS DESCRIPTION	14

SERVICE DATA	15
---------------------------	----

APPENDIX	
CIRCUIT DIAGRAM	

SAFETY INSTRUCTIONS AND MAINTENANCE

WARNING: BEFORE SERVICING THIS CHASSIS, READ THE "X-RAY RADIATION PRECAUTION", "SAFETY PRECAUTION" AND "PRODUCT SAFETY NOTICE" INSTRUCTION BELOW.

X-RAY RADIATION PRECAUTION

1. The EHT must be checked every time the TV is serviced to ensure that the CRT does not emit X-ray radiation as result of excessive EHT voltage. The maximum EHT voltage permissible in any operating circumstances must not exceed the rated value. When checking the EHT, use the High Voltage Check procedure in this manual using an accurate EHT voltmeter.
2. The only source of X-RAY radiation in this TV is the CRT. The TV minimizes X-RAY radiation, which ensures safety during normal operation. To prevent X-ray radiation, the replacement CRT must be identical to the original fitted as specified in the parts list.
3. Some components used in this TV have safety related characteristics preventing the CRT from emitting X-ray radiation. For continued safety, replacement component should be made after referring the PRODUCT SAFETY NOTICE below.
4. Service and adjustment of the TV may result in changes in the nominal EHT voltage of the CRT anode. So ensure that the maximum EHT voltage does not exceed the rated value after service and adjustment.

SAFETY PRECAUTION

WARNING: REFER SERVICING TO QUALIFIED SERVICE PERSONNEL ONLY.

1. The TV has a nominal working EHT voltage. Extreme caution should be exercised when working on the TV with the back removed.
 - 1.1 Do not attempt to service this TV if you are not conversant with the precautions and procedures for working on high voltage equipment.
 - 1.2 When handling or working on the CRT, always discharge the anode to the TV chassis before removing the anode cap in case of electric shock.
 - 1.3 The CRT, if broken, will violently expel glass fragments. Use shatterproof goggles and take extreme care while handling.
 - 1.4 Do not hold the CRT by the neck as this is a very dangerous practice.
2. It is essential that to maintain the safety of the customer all power cord forms be replaced exactly as supplied from factory.
3. Voltage exists between the hot and cold ground when the TV is in operation. Install a suitable isolating transformer of beyond rated overall power when servicing or connecting any test equipment for the sake of safety.

4. When replacing ICs, use specific tools or a static-proof electric iron with small power (below 35W).
5. Do not use a magnetized screwdriver when tightening or loosening the deflection yoke assembly to avoid electronic gun magnetized and decrement in convergence of the CRT.
6. When remounting the TV chassis, ensure that all guard devices, such as nonmetal control buttons, switch, insulating sleeve, shielding cover, isolating resistors and capacitors, are installed on the original place.
7. Replace blown fuses within the TV with the fuse specified in the parts list.
8. When replacing wires or components to terminals or tags, wind the leads around the terminal before soldering. When replacing safety components identified by the international hazard symbols on the circuit diagram and parts list, it must be the company-approved type and must be mounted as the original.
9. Keep wires away from high temperature components.

PRODUCT SAFETY NOTICE

CAUTION: FOR YOUR PROTECTION, THE FOLLOWING PRODUCT SAFETY NOTICE SHOULD BE READ CAREFULLY BEFORE OPERATING AND SERVICING THIS TV SET.

1. Many electrical and mechanical components in this chassis have special safety-related characteristics. These characteristics are often passed unnoticed by a visual inspection and the X-ray radiation protection afforded by them cannot necessarily be obtained by using replacements rated at higher voltages or wattage, etc. Components which have these special safety characteristics in this manual and its supplements are identified by the international hazard symbols on the circuit diagram and parts list. Before replacing any of these components read the parts list in this manual carefully. Substitute replacement components which do not have the same safety characteristics as specified in the parts list may create X-ray radiation.
2. Do not slap or beat the cabinet or CRT, since this may result in fire or explosion.
3. Never allow the TV sharing a plug or socket with other large-power equipment. Doing so may result in too large load, causing fire.
4. Do not allow anything to rest on or roll over the power cord. Protect the power cord from being walked on, modified, cut or pinched, particularly at plugs.
5. Do not place any objects, especially heavy objects and lightings, on top of the TV set. Do not install the TV near any heat sources such as radiators, heat registers, stove, or other apparatus that produce heat.
6. Service personnel should observe the SAFETY INSTRUCTIONS in this manual during use and servicing of this TV set. Otherwise, the resulted damage is not protected by the manufacturer.

SAFETY SYMBOL DESCRIPTION



The lightning symbol in the triangle tells you that the voltage inside this product may be strong enough to cause an electric shock. Extreme caution should be exercised when working on the TV with the back removed.



This is an international hazard symbol, telling you that the components identified by the symbol have special safety-related characteristics.



FDA This symbol tells you that the critical components identified by the FDA marking have special safety-related characteristics.

UL This symbol tells you that the critical components identified by the UL marking have special safety-related characteristics.

C UL This symbol tells you that the critical components identified by the C-UL marking have been evaluated to the UL and C-UL standards and have special safety-related characteristics.

VDE This symbol tells you that the critical components identified by the VDE marking have special safety-related characteristics.

MAINTENANCE

1. Place the TV set on a stable stand or base that is of adequate size and strength to prevent it from being accidentally tipped over, pushed off, or pulled off. Do not place the set near or over a radiator or heat register, or where it is exposed to direct sunlight.
2. Do not install the TV set in a place exposed to rain, water, excessive dust, mechanical vibrations or impacts.
3. Allow enough space (at least 10cm) between the TV and wall or enclosures for proper ventilation.
4. Slots and openings in the cabinet should never be blocked by clothes or other objects.
5. Please power off the TV set and disconnect it from the wall immediately if any abnormal condition are met, such as bad smell, belching smoke, sparkling, abnormal sound, no picture/sound/raster. Hold the plug firmly when disconnecting the power cord.
6. Unplug the TV set from the wall outlet before cleaning or polishing it. Use a dry soft cloth for cleaning the exterior of the TV set or CRT screen. Do not use liquid cleaners or aerosol cleaners.

ADJUSTMENTS

SET-UP ADJUSTMENTS

The following adjustments should be made when a complete realignment is required or a new picture tube is installed.

Perform the adjustments in the following order:

1. Color purity
2. Convergence
3. White balance

Notes:

- ① The purity/convergence magnet assembly and rubber wedges need mechanical positioning.
- ② For some picture tubes, purity/ convergence adjustments are not required.

1. Color Purity Adjustment

Preparation:

Before starting this adjustment, adjust the vertical sync, horizontal sync, vertical amplitude and focus.

- 1.1 Face the TV set north or south.
- 1.2 Connect the power plug into the wall outlet and turn on the main power switch of the TV set.
- 1.3 Operate the TV for at least 15 minutes.
- 1.4 Degauss the TV set using a specific degaussing coil.
- 1.5 Set the brightness and contrast to maximum.
- 1.6 Counter clockwise rotate the R /B low brightness potentiometers to the end and rotate the green low brightness potentiometer to center.
- 1.7 Receive green raster pattern signals.
- 1.8 Loosen the clamp screw holding the deflection yoke assembly and slide it forward or backward to display a vertical green zone on the screen. Rotate and spread the tabs of the purity magnet around the neck of the CRT until the green zone is located vertically at the center of the screen.
- 1.9 Slowly move the deflection yoke assembly forward or backward until a uniform green screen is obtained.
- 1.10 Tighten the clamp screw of the assembly temporarily. Check purity of the red raster and blue raster until purities of the three rasters meet the requirement.

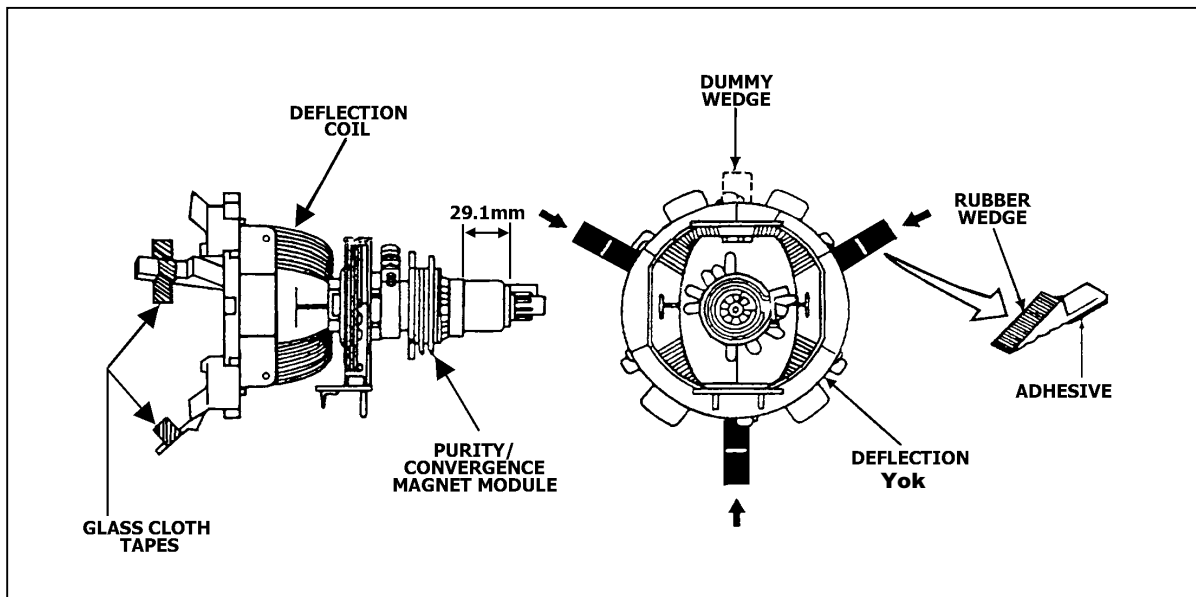

Fig. 1

2. Convergence Adjustment

Preparation:

Before attempting any convergence adjustment, the TV should be operated for at least 15 minutes.

2.1 Center convergence adjustment

2.1.1 Receive dot pattern.

2.1.2 Adjust the brightness/contrast controls to obtain a sharp picture.

2.1.3 Adjust two tabs of the 4-pole magnet to change the angle between them and red and blue vertical lines are superimposed each other on the center of the screen.

2.1.4 Turn both tabs at the same time keeping the angle constant to superimpose red and blue horizontal on the center of the screen.

2.1.5 Adjust two tabs of the 6-pole magnet to superimpose red/blue line and green line.

2.1.6 Remember red and blue movement. Repeat steps 2.1.3~2.1.5 until optimal convergence is obtained.

2.2 Circumference convergence adjustment

2.2.1 Loosen the clamp screw holding the deflection yoke assembly and allow it tilting.

2.2.2 Temporarily put the first wedge between the picture tube and deflection yoke assembly. Move front of the deflection yoke up or down to obtain better convergence in circumference. Push the mounted wedge in to fix the yoke temporarily.

2.2.3 Put the second wedge into bottom.

2.2.4 Move front of the deflection yoke to the left or right to obtain better convergence in circumference.

2.2.5 Fix the deflection yoke position and put the third wedge in either upper space. Fasten the

deflection yoke assembly on the picture tube.

- 2.2.6 Detach the temporarily mounted wedge and put it in either upper space. Fasten the deflection yoke assembly on the picture tube.
- 2.2.7 After fastening the three wedges, recheck overall convergence and ensure to get optimal convergence. Tighten the lamp screw holding the deflection yoke assembly.

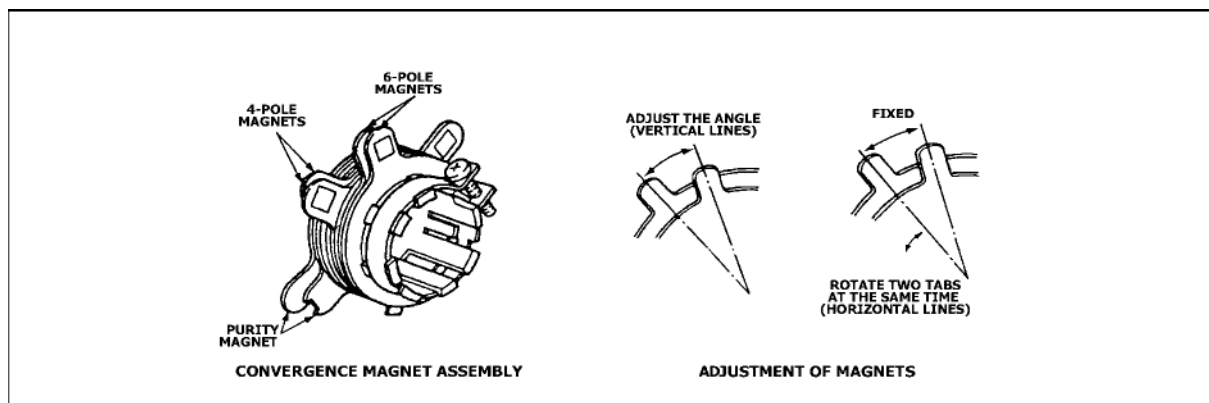

Fig. 2

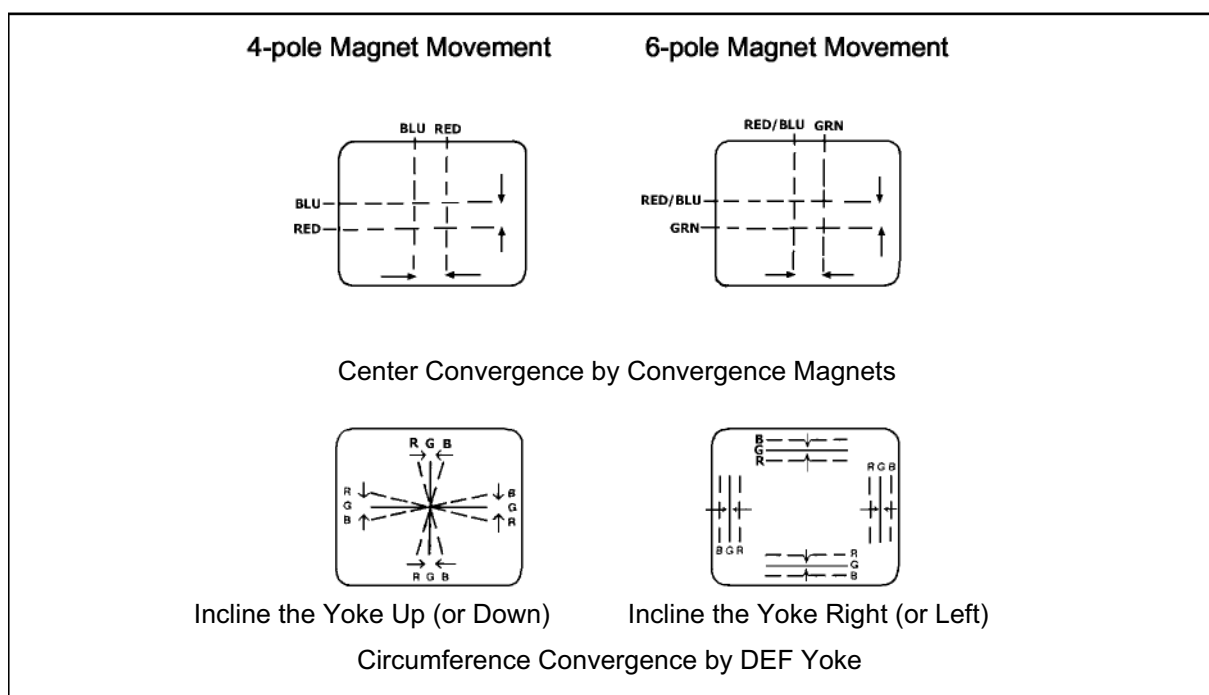

Fig.3

3. White Balance Adjustment

Generally, white balance adjustment is made with professional equipment. It's not practical to get good white balance only through manual adjustment. For TVs with I²C bus control, change the bus data to adjust white balance.

CIRCUIT ADJUSTMENTS

Preparation:

Circuit adjustments should be made only after completion of set-up adjustments.

Circuit adjustments can be performed using the adjustable components inside the TV set. For TVs with I C bus control, first change the bus data.

1. Degaussing

A degaussing coil is built inside the TV set. Each time the TV is powered on, the degaussing coil will automatically degauss the TV. If the TV is magnetized by external strong magnetic field, causing color spot on the screen, use a specific degausser to demagnetize the TV in the following ways. Otherwise, color distortion will be shown on the screen.

- 1.1 Power on the TV set and operate it for at least 15 minutes.
- 1.2 Receive red full-field pattern.
- 1.3 Power on the specific degausser and face it to the TV screen.
- 1.4 Turn on the degausser. Slowly move it around the screen and slowly take it away from the TV.
- 1.5 Repeat the above steps until the TV is degaussed completely.

2. Confirmation and Adjustment for Voltage

Caution: +B voltage has close relation to high voltage. To prevent X-ray radiation, set +B voltage to the rated value.

- 2.1 Make sure that the supply voltage is within the range of the rated value.
- 2.2 Connect a digital voltmeter to the voltage output terminal of the main PCB. Power on the TV and set the brightness and sub-brightness to minimum. Ensure that the voltage from the main PCB reads as follows.
- 2.3 Regulate voltage adjustment components on the power section until the +B the voltage reaches the rated value.

Table 1

Test Point	Voltage (V)	Test Point	Voltage (V)
TP-115V	$117\text{V} \pm 1.5\text{V}$	TP-18V	$23\text{V} \pm 2\text{V}$
TP-15V	$15.5\text{V} \pm 1\text{V}$	TP-5V	$5\text{V} \pm 0.5\text{V}$
TP-3.3V	$3.3\text{V} \pm 0.3\text{V}$	TP-8V	$8\text{V} \pm 1\text{V}$
TP-12V	$13\text{V} \pm 2\text{V}$	TP--12V	$-13\text{V} \pm 2\text{V}$
TP-195V	$196\text{V} \pm 2\text{V}$		

Note:

It's impossible to check the power part separately from the main chassis board as the part is mounted on the main chassis board. The power components, etc. should be checked for burnout when power-on. If burned out, do not power on the TV again until the cause is found out.

3. High Voltage Inspection

Measure voltages of test points on the main PCB with the digital voltmeter. Measure the CRT high voltage with the high-voltage testing equipment and heater voltage with the high-frequency effective voltmeter. The rated values are shown as below.

Table 2

Test Point	Voltage (V)
Negative of VD491	$196 \pm 2V$
21"FS-CRT-anode	$26 \pm 1.5KV$
21"PF-CRT-anode	$27 \pm 1.5KV$
Heater	$6.3 \pm 0.3V_{rms}$

4. Focus Adjustment

Caution: Dangerously high voltages are present inside the TV. Extreme caution should be exercised when working on the TV with the back removed.

4.1 After removing the back cover, look for the FBT on the main PCB. There should be a FCB on the FBT.

4.2 Power on the TV and preheat it for 15 min.

4.3 Receive a normal TV signal. Rotate knob of the FCB until you get a sharp picture.

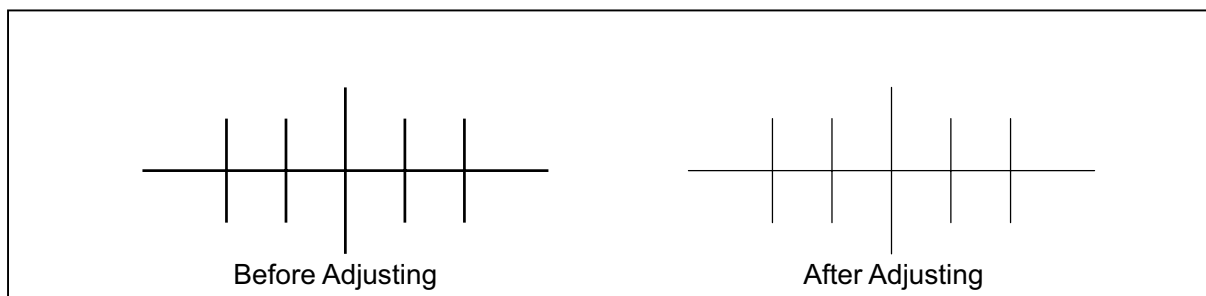

Fig. 4

5. Safety Inspection

5.1 Inspection for insulation and voltage-resistant

Perform safety test for all naked metal of the TV. Supply high voltage of 2500V AC, 50Hz (limit current of 10mA) between all naked metal and cold ground. Test every point for 3 sec. and ensure no arcing and sparking.

5.2 Requirements for insulation resistance

Measure resistance between naked metal of the TV and feed end of the power cord to be infinity with a DC-500 high resistance meter and insulation resistance between the naked metal and

degaussing coil to be over 20M .

6. SERVICE mode

6.1 To enter the DESIGN/SERVICE mode

Set the volume to 0. Then press and hold the MUTE button on the remote control, and press the MENU button on the TV to enter the SERVICE mode. To exit from the S mode, turn off the TV set by the POWER button on the remote control.

Caution: The user service mode adjustment can be changed only when service personnel adjust the whole set data during servicing. As the control data have dramatic effects on functions and performance of the TV, service personnel should not tell user how to enter the SERVICE mode to avoid improper data settings.

6.2 Adjustments and bus data (GDET0201-02)

Table 3 Function Description for Bus Data

SERVICE mode	adjust	description	note
STS0/1/2/3/4		UOC system surveillance display	
IFP1	00	IF PRESET VALUE1	#
IFP2	00	IF PRESET VALUE2	#
TINT	20	BASE BAND TINT CONTROL	#
TWBK	88	TIME OF "WIDE BLANKING"	#
PWL	15	Peak white limited	#
OIF	20	Off-set if demodulatour	#
5HP/6HP	adjustable	HOR PARALLELOGRAM CORRECTION	*
5HB/6HB	adjustable	HOR BOW CORRECTION	*
5HSH/6HSH	adjustable	HORIZONTAL SHIFT	*
5HZD/6HZD	0A	DVD HORIZONTAL SHIFT	***
5EWW/6EWW	adjustable	E-W WIDTH	*
5EWP/6EWP	adjustable	E-W PARABOLA WIDTH	*
5UCR/6UCR	adjustable	E-W UPPER CORNER PARABOLA	*
5LCR/6LCR	adjustable	E-W BOTTOM CORNER PARABOLA	*
5TC/6TC	adjustable	E-W TRAPEZIUM	*
5VSL/6VSL	adjustable	VERTICAL SLOPE	*
5VAM/6VAM	adjustable	VERTICAL AMPLITUDE	*
5SCL/6SCL	adjustable	VERTICAL S CORRECTION	*
5VSH/6VSH	adjustable	VERTICAL SHIFT	*
5VZD/6VZD	00	DVD VERTICAL SHIFT	***
5VOF/6VOF	26	OSDVERTICAL SHIFT	**
RED	20	BLACK LEVEL OFFSET:R	**
GRN	20	BLACK LEVEL OFFSET:G	**
WPR	1F	WHITE POINT R	**
WPG	1F	WHITE POINT G	**
WPB	1F	WHITE POINT B	**
DRED	00	DVD BLACK LEVEL OFFSET:R	**
DGRN	50	DVD BLACK LEVEL OFFSET:R	**

SERVICE MANUAL

DWPR	00	DVD WHITE POINT R	**
DWPG	00	DVD WHITE POINT G	**
DWPB	00	DVD WHITE POINT B	**
YDFP/YDFN/ YDFS/YDAV	07	LUMINANCE DELAY TIME	#
TOP	adjustable	AGC TAKE OVER	*
VOL	2A	Volume control	***
VOLA	20	Dummy AVL level	#
CORE	03	Core noise reduction	#
HLOG	02	the horizontal position LOGO	***
VLG1	0A	The first line vertical position of LOGO	**
VLG2	0E	The second line vertical position of LOGO	**
COL1	04	The color of first line LOGO	**
COL2	04	The color of second line LOGO	**
TIME	0F	The time of No signal auto off	#
IFFS	03	IF 38MHZ/38.9MHZ	#
HDOL	0A	Cathode drive level	#
AGC	03	AGC time	#
VG2B	1A	VG2 bright set	***
SBRI	24	Sub bright	***
MBRI	30	Max bright	***
SCON	20	Sub contrast	***
MCON	39	Max contrast	***
SCOL	32	Sub color	#
OP1	AF	Optional 1	***
OP2	02	Optional 2	***
OP3	09	Optional 3	***
OP4	00	Optional 4	***
OP5	00	Optional 5	***
OP6	F6	Optional 6	***
OP7	60	Optional 7	***
OP8	18	Optional 8	***
OP9	07	Optional 9	***
INIT		EEPROM init	#
VG2		VG2	*
VSD		VSD	#

Table4 Optional Setup

	BIT	NAME	DESCRIPTION	DATA
OP1	0	OP_HOTEL	Hotel model (1: yes, 0: no)	<u>1</u>
	1	OP_236	Channel number setup, 1: 236; 0: 100	<u>1</u>
	2	OP_NTSC	NTSC setup, 1: yes, 0: no	1
	3	OP_AV2	2 AV input, 1: 2 AV input	1
	4	OP_SVSH	S-VIDEO input, 1: yes, 0: no	0
	5	OP_DVD	DVD input, 1:yes,0:no	1
	6	OP_SCART	SCART ,1: yes; 0: no	1
OP2	7	OP_OSO	Switch off in vertical overscan	<u>1</u>
	0	OP_AVL	AVL, 1: yes; 0: no(slim crt)	<u>0</u>
	1	OP_AUTO_SOUND	AUTO SOUND	<u>1</u>
	2	OP_NOT_1	Text language setup (OP_NOT_3/2/1) ; (only for text)	0

SERVICE MANUAL

	3	OP_NOT_2		0
	4	OP_NOT_3		0
	5	OP_USER_LOGO	USER' S LOGO SETUP	0
	6	OP_ON_BLACK	1: blue back, 0: black back	0
	7	OP_FSL		0
OP3	0	OP_ENGLISH	1: ENGLISH OSD, 0:NO ENGLISH OSD	1
	1	OP_CZECH	1: CZECH OSD, 0:NO CZECH OSD	1
	2	OP_SLOVAK	1: SLOVAK OSD, 0:NO SLOVAK OSD	1
	3	OP_RUSSIAN	1: RUSSIAN OSD, 0:NO RUSSIAN OSD	1
	4	OP_FRENCH	1: FRENCH OSD, 0:NO FRENCH OSD	1
	5	OP_GERMAN	1: GERMAN OSD, 0:NO GERMAN OSD	1
	6	OP_ITALY	1: ITALY OSD, 0:NO ITALY OSD	1
OP4	7	OP_SPANISH	1: SPANISH OSD, 0:NO SPANISH OSD	1
	0	OP_PORTUGUESE	1: PORTUGUESE OSD, 0:NO PORTUGUESE OSD	1
	1	OP_SERBIAN	1: SERBIAN OSD, 0:NO SERBIAN OSD	1
	2	OP_TURKISH	1: TURKISH OSD, 0:NO TURKISH OSD	1
	3	OP_POLISH	1: POLISH OSD, 0:NO POLISH OSD	1
	4	OP_BULGARIAN	1: BULGARIAN OSD, 0:NO BULGARIAN OSD	1
	5	OP_ROMANIAN	1: ROMANIAN OSD, 0:NO ROMANIAN OSD	1
OP5	6	OP_CROATIAN	1: CROATIAN OSD, 0:NO CROATIAN OSD	1
	7	OP_HUNGARIAN	1: HUNGARIAN OSD, 0:NO HUNGARIAN OSD	1
	0	OP_UKRAIN	1: UKRAIN OSD, 0:NO UKRAIN OSD	1
	1	OP_ARABIC	1: ARABIC OSD, 0:NO ARABIC OSD	1
	2	OP_FARSI	1: FARSI OSD, 0:NO FARSI OSD	1
	3			0
	4			0
OP6	5	OP_RFTOAV	1:SCART, 0: RCA	0
	6	OP_TDA1517	1: TDA1517 0: TFA9842AJ	0
	7	OP_FAKE_AVL	0=AVL, 1=fake AVL	0
	0	OP_AV_ON	1: AV shutdown, AV restart; 0: TV restart	1
	1	OP_DIRECT_SWITCH	1: memory-restart; 0: power-on and standby	1
	2	OP_HCO	EHT tracking mode	0
	3	OP_CHH_LOGO	1: changhong logo, 0: no	0
OP7	4	OP_SOUND_DK	D/K	1
	5	OP_SOUND_BG	B/G	1
	6	OP_SOUND_I	I	1
	7	OP_SOUND_M	M	1
	0	OP_AUTO_LANG0	OP_AUTO_LANG4/3/2/1/0:	0
	1	OP_AUTO_LANG1	ENGLISH (00000)	0
	2	OP_AUTO_LANG2	CZECH (00001)	0
OP8	3	OP_AUTO_LANG3	SLOVAK (00010)	0
	4	OP_AUTO_LANG4	0
	5	OP_FORF	OP_FORF/FORF:	1
	6	OP_FORF	00-AUTO 60HZ, 01-KEEP LAST, 10-FORCE 60HZ, 11-AUTO 50HZ	1
OP8	7	OP_HOTEL_ON_PROG	1:Startup on channel 1 (hotel model available)	0
	0	OP_AUTO_TEST	Power-on self-test , 1:yes, 0, no	0
	1	OP_PSNS	sensibility	0
	2	OP_BSCREEN	Black screen: 1 Yes;0:No	0
	3	OP_SECAM	SECAM selecctable, 1:SECAM, 0:no SECSM	1
	4	OP_DFL	Disable flash protection	1

SERVICE MANUAL

	5	OP_SIF		0
	6	OP_EXT_SIF0		0
	7	OP_EXT_SIF1		0
0P9	0	OP-TUNER	0: TAF5-E4I22 1: TAF5-C4I21	1
	1	OP_TINT	TINT adjustable	0
	2	OP_FMWS	WINDOW OF SOUND PLL: +/-200KHZ	1
	3	OP_FMWS1	WINDOW OF SOUND PLL: +/-600KHZ	0
	4	OP_OSVE	Overscan vertical, 1:yes, 0: no	0
	5	OP_FFI		0
	6	OP_SPEED1	Program quickly, 1:yes, 0: no	0
	7	OP_SPEED0	Program slowly, 1:yes, 0: no	0

Notes:

The data sheet may differ dependent on different models.

The data sheet may differ dependent on different CRTs for the same model.

STRUCTURE AND CHISSIS FUNCTION DESCRIPTION

1. STRUCTUE BLOCK DIAGRAM

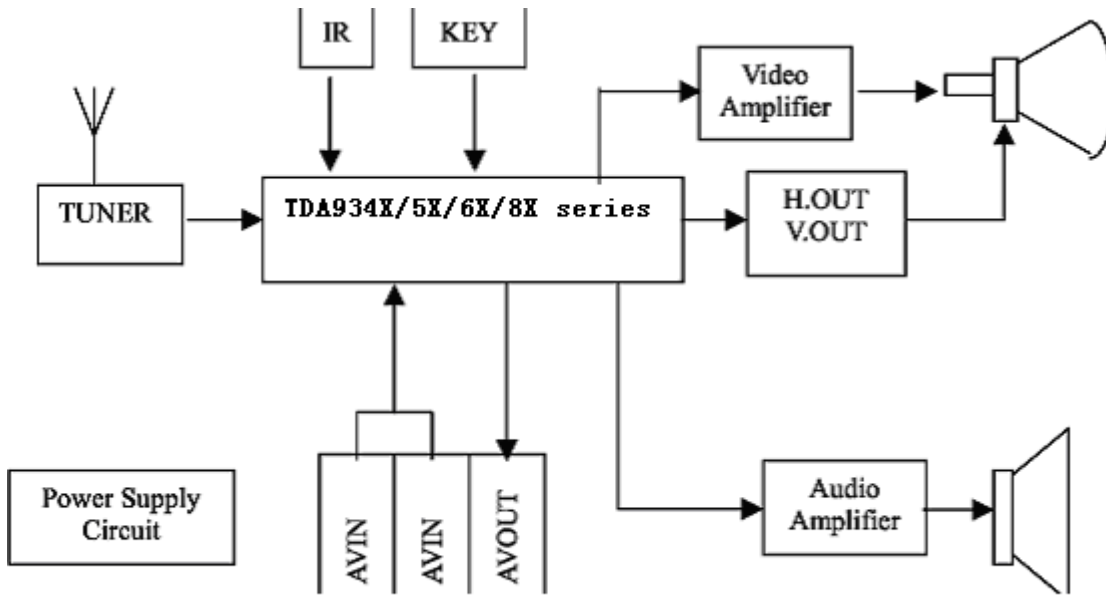

Fig.4

Structure Block Diagram for ETE-2 Chassis Series

2. CHASSIS DESCRIPTION

2.1 General Description

ETE-2 chassis is applied in PF21GB300 series.

By use of philips UOC for TV small signal processing and bus control, the chassis enables TV tuning, adjustment, control and picture correction, featuring high-integration, high-performance-to-price ratio and high-reliability and compact circuit with fewer external components. The chassis, widely used in small and medium TVs, provides much more convenience for manufacturing and technical service. It includes:

UOC TDA9384PS/N3/3 for PAL/NTSC /SECAM s m a l l signal processing and bus control

EEPROM AT24C08 for data memory

TDA4863AJ for vertical output power amplifying

TFA9842AJ for audio power amplifying

Thick-film IC STR-G5653 for power circuit adjustment and control

2.2 The following features are available in the chassis:

Color systems: PAL, NTSC, SECAM

Sound systems: D/K, B/G, I, M

236 programs preset

AV stereo

I.C bus control Electronic

program table

Intelligent lock

Biorhythm

2.3 The chassis mainly uses the following ICs and assemblies.

Table 5 Key ICs and Assemblies

Serial No.	Position	Type	Description
1	N200	AT24C08	EERPOM
2	N100	TDA9384PS/N3/3(slim crt) TDA9381PS/N3/3 etc.	(Small signal processor + micro control unit (MCU))
3	N601	TFA9842AJ	Audio power amplifier
4	N300	TDA4863AJ/TDA4864AJ	Vertical scan output stage circuit
5	N801	STR-G5653	Switch-mode power supply control
6	A001	TAF5-C4I21 /TAF5-E4I22	Tuner

SERVICE DAT

1. TV signal processor TDA935X/6X/8X PS-N3 series

1.1 GENERAL DESCRIPTION

The various versions of the TDA935X/6X/8X/9X PS-N3 series combine the functions of a video processor together with a -Controller and US Closed Caption decoder. Most versions have a Teletext decoder on board. The Teletext decoder has an internal RAM memory for 1 or 10 page text. The ICs are intended to be used in economy television receivers with 90 and 110 picture tubes.

The ICs have supply voltages of 8 V and 3.3 V and they are mounted in an SDIP-64 envelope.

The features are given in the following feature list.

1.2 FEATURES TV processor

Available in TDA935X/6X/8X PS versions

- Multi-standard vision IF circuit with alignment-free PLL demodulator
- Internal (switchable) time-constant for the IF-AGC circuit
- The mono intercarrier sound circuit has a selective FM-PLL demodulator which can be switched to the different FM sound frequencies (4.5/5.5/6.0/6.5 MHz). The quality of this system is such that the external band-pass filters can be omitted.
- The FM-PLL demodulator can be set to centre frequencies of 4.74/5.74 MHz so that a second sound channel can be demodulated. In such an application it is necessary that an external band pass filter is inserted.
- Integrated chrominance trap circuit
- Integrated luminance delay line with adjustable delay time
- Picture improvement features with peaking (with switchable centre frequency, depeaking, variable positive/negative overshoot ratio and video dependent coring) and blue- and black stretching. All features are available for CVBS, Y/C and YPBPR signals.
- Tint control for external RGB/YPBPR signals
- Integrated chroma band-pass filter with switchable centre frequency
- Only one reference (12 MHz) crystal required for the -Controller, Teletext- and the colour decoder
- Multi-standard colour decoder with automatic search system
- Internal base-band delay line
- Indication of the Signal-to-Noise ratio of the incoming CVBS signal
- A linear RGB/YUV/YPBPR input with fast blanking for external RGB/YUV sources. The synchronisation circuit can be connected to the incoming Y signal. The Text/OSD signals are internally supplied from the -Controller/Teletext decoder.
- RGB control circuit with 'Continuous Cathode Calibration', white point and black level off-set adjustment so that the colour temperature of the dark and the light parts of the screen can be chosen independently.
- 2 levels of contrast reduction of main picture possible during OSD/Text insertion ('halftone')
- OSD/Text gain reduction control
- Adjustable 'wide blanking' of the RGB outputs
- Horizontal synchronization with two control loops and alignment-free horizontal oscillator
- Vertical count-down circuit
- Vertical driver optimized for DC-coupled vertical output stages

- Horizontal and vertical geometry processing
- Horizontal and vertical zoom function for 16: 9 applications
- Horizontal parallelogram and bow correction for large screen picture tubes
- Low-power start-up of the horizontal drive circuit
- Macrovision keying possibility for horizontal synchronisation.

Available in TDA935X/6X/8X PS versions

- A choice can be made between versions with mono intercarrier sound FM demodulator and versions with QSS IF amplifier.
- Source selection between the 'internal' CVBS and an external CVBS or Y/C signal

Controller

- 80C51 -controller core standard instruction set and timing
- 1 μ s machine cycle
- 32 - 128Kx8-bit late programmed ROM
- 3 - 12Kx8-bit Auxiliary RAM (shared with Display)
- Interrupt controller for individual enable/disable with two level priority
- Two 16-bit Timer/Counter registers
- One 16-bit Timer with 8-bit P re-scaler
- WatchDog timer
- Auxiliary RAM page pointer
- 16-bit Data pointer
- Stand-by, Idle and Power Down modes
- 14 bits PWM for Voltage Synthesis Tuning
- 8-bit A/D converter
- 4 multiplexed inputs for the A/D converter and 5 PWM (6-bits) outputs for control of TV analogue signals (TDA95XX series)
- 4 pins which can be programmed as general I/O pin, ADC input or PWM (6-bit) output (TDA93XX series)

Data Capture

- Text memory for 1 or 10 pages
- In the 10 page versions inventory of transmitted Teletext pages stored in the Transmitted Page Table (TPT) and Subtitle Page Table (SPT)
- Data Capture for US Closed Caption
- Data Capture for 525/625 line WST, VPS (PDC system A) and Wide Screen Signalling (WSS) bit decoding
- Automatic selection between 525 WST/625 WST
- Automatic selection between 625 WST/VPS on line 16 of VBI
- Real-time capture and decoding for WST Teletext in Hardware, to enable optimized -processor throughput
- Automatic detection of FASTEXT transmission
- Real-time packet 26 engine in Hardware for processing accented, G2 and G3 characters
- Signal quality detector for video and WST/VPS data types
- Comprehensive teletext language coverage
- Full Field and Vertical Blanking Interval (VBI) data capture of WST data

Display

- Teletext and Enhanced OSD modes
- Features of level 1.5 WST and US Close Caption
- Serial and Parallel Display Attributes
- Single/Double/Quadruple Width and Height for characters
- Scrolling of display region
- Variable flash rate controlled by software
- Enhanced display features including overlining, underlining and italics
- Soft colours using CLUT with 4096 colour palette
- Globally selectable scan lines per row (9/10/13/16) and character matrix [12x10, 12x13, 12x16 (VxH)]
- Fringing (Shadow) selectable from N-S-E-W direction
- Fringe colour selectable
- Meshing of defined area
- Contrast reduction of defined area
- Cursor
- Special Graphics Characters with two planes, allowing four colours per character
- 32 software redefinable On-Screen display characters
- 4 WST Character sets (G0/G2) in single device (e.g. Latin, Cyrillic, Greek, Arabic)
- G1 Mosaic graphics, Limited G3 Line drawing characters
- WST Character sets and Closed Caption Character set in single

QUICK REFERENCE DATA

Table 6

SYMBOL	PARAMETER	MIN.	TYP.	MAX.	UNIT
Supply					
V_P	supply voltages		8.0/3.3		V
I_P	supply current ($V_P = 8\text{ V}$)		135		mA
I_P	supply current ($V_P = 3.3\text{ V}$)		60		mA
Input voltages					
$V_{iVIF(rms)}$	video IF amplifier sensitivity (RMS value)		75		V
$V_{iSIF(rms)}$	QSS sound IF amplifier sensitivity (RMS value)		45		dBV
$V_{iAUDIO(rms)}$	external audio input (RMS value)		500		mV
$V_{iCVBS(p-p)}$	external CVBS/Y input (peak-to-peak value)		1.0		V
$V_{iCHROMA(p-p)}$	external chroma input voltage (burst amplitude) (peak-to-peak value)		0.3		V
$V_{iRGB(p-p)}$	RGB inputs (peak-to-peak value)		0.7		V
$V_{iY(p-p)}$	luminance input signal (peak-to-peak value)		1.4 / 1.0		V
$V_{iU(p-p)} /$ $V_{iPB(p-p)}$	U / Pb input signal (peak-to-peak value)		1.33 / +0.7		V
$V_{iV(p-p)} /$ $V_{iPR(p-p)}$	V / PR input signal (peak-to-peak value)		1.05 / +0.7		V
Output signals					
$V_{o(IFVO)(p-p)}$	demodulated CVBS output (peak-to-peak value)		2.0		V
$V_{o(QSSO)(rms)}$	sound IF intercarrier output in QSS versions (RMS value)		100		mV
$V_{o(AMOUT)(rms)}$	demodulated AM sound output in QSS versions (RMS value)		500		mV
$V_{o(CVBSO)(p-p)}$	selected CVBS output (peak-to-peak value)		2.0		V
$I_{o(AGCOUT)}$	tuner AGC output current range	0		5	mA
$V_{oRGB(p-p)}$	RGB output signal amplitudes (peak-to-peak value)		2.0		V
I_{oHOUT}	horizontal output current	10			mA
I_{oVERT}	vertical output current (peak-to-peak value)	1			mA
I_{oEWD}	EW drive output current	1.2			mA

BLOCK DIAGRAM

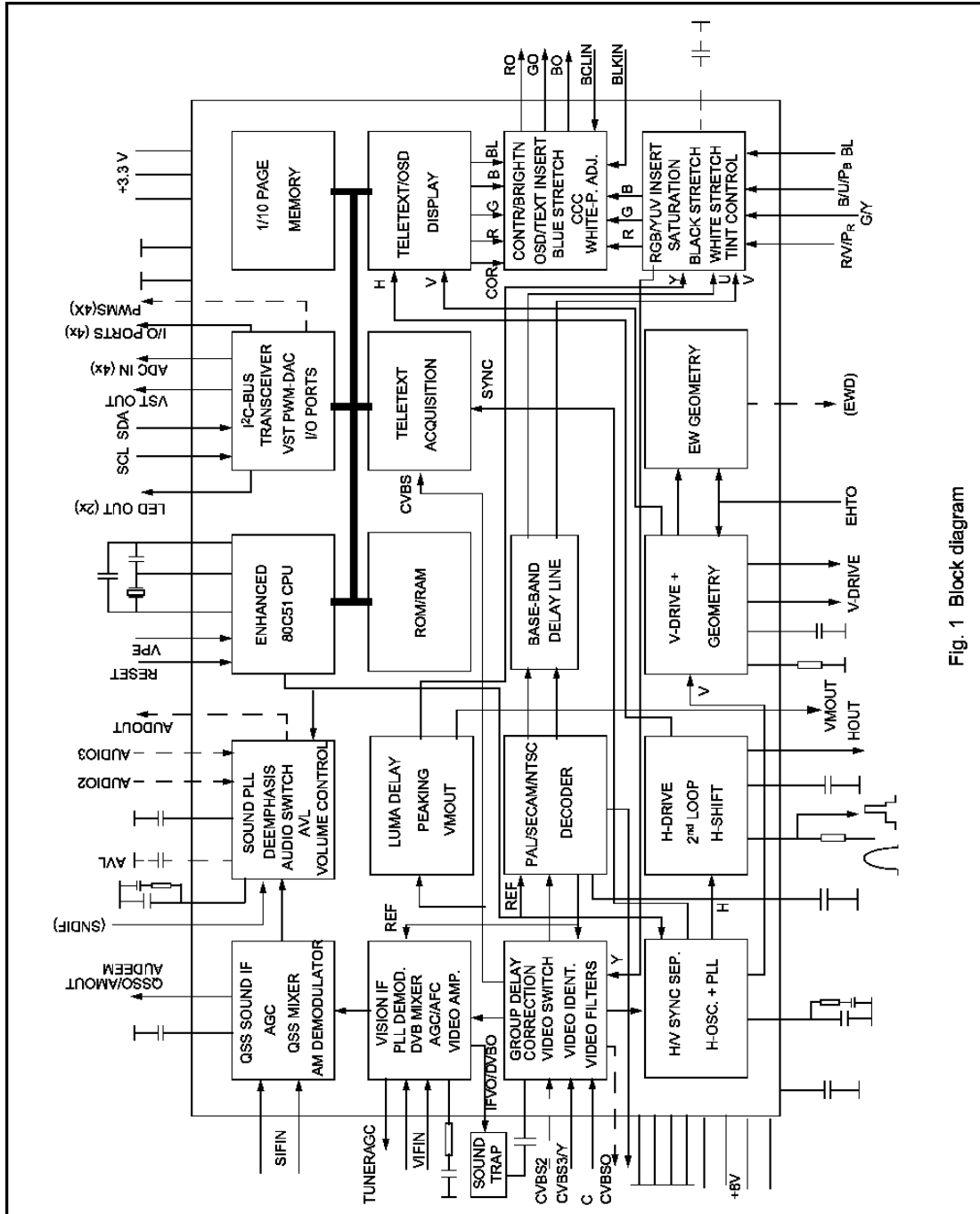

Fig.5

Fig. 1 Block diagram

PINNING

Table 7

SYMBOL	PIN	DESCRIPTION
P3.1/ADC1/PWM1	6	port 3.1 or ADC1 input or PWM1 output
P3.2/ADC2/PWM2	7	port 3.2 or ADC2 input or PWM2 output
P3.3/ADC3/PWM3	8	port 3.3 or ADC3 input or PWM3 output
VSSC/P	9	digital ground for -Controller core and periphery

SERVICE MANUAL

P0.5	10	port 0.5 (8 mA current sinking capability for direct drive of LEDs)
P0.6/CVBSTD	11	port 0.6 (8 mA current sinking capability for direct drive of LEDs) or Composite video input. A positive-going 1V(peak-to-peak) input is required
VSSA	12	digital ground of TV-processor
SECPLL	13	SECAM PLL decoupling
VP2	14	2 nd supply voltage TV-processor (+8V)
DECDIG	15	supply voltage decoupling of digital circuit of TV-processor
PH2LF	16	phase-2 filter
PH1LF	17	phase-1 filter
GND3	18	ground 3 for TV-processor
DECBG	19	bandgap decoupling
AVL/EWD ⁽¹⁾	20	Automatic Volume Levelling (90versions)/ E-W drive output (110versions)
VDRB	21	vertical drive B output
VDRA	22	vertical drive A output
IFIN1	23	IF input 1
IFIN2	24	IF input 2
IREF	25	reference current input
VSC	26	vertical sawtooth capacitor
AGCOUT	27	tuner AGC output
SIFIN1/AUDEEM ⁽²⁾	28	SIF input 1 / audio deemphasis
SIFIN2/DECSDEM ⁽²⁾	29	SIF input 2 / decoupling sound demodulator
GND2	30	ground 2 for TV processor
SNDPLL/SIFAGC ⁽²⁾	31	narrow band PLL / AGC sound IF
AVL/REF0/SNDIF/ AMOUT ⁽²⁾	32	Automatic Volume Levelling / subcarrier reference output / sound IF input / AM output
HOUT	33	horizontal output
FBISO	34	flyback input/sandcastle output
QSSO/AMOUT/ AUDEXT ⁽²⁾	35	QSS intercarrier output / AM output / external audio input
EHTO	36	EHT/overvoltage protection input
PLLIF	37	IF-PLL loop filter
IFVO/SVO/DVBO ⁽²⁾	38	IF video output / selected CVBS output / DVB output (QFP-80)
VP1	39	main supply voltage TV processor
CVBS1	40	internal CVBS input
GND	41	ground for TV processor
CVBS3/Y	42	CVBS3/Y input
C	43	chroma input
AUDOUT / AMOUT ⁽²⁾	44	audio output / AM audio output (volume controlled)
INSSW2	45	2 nd RGB / YUV insertion input
R2/V/P _R -IN	46	2 nd R input / V (R-Y) input / P _R input
G2/Y-IN	47	2 nd G input / Y input
B2/U/P _B -IN	48	2 nd B input / U (B-Y) input / P _B input
BCLIN	49	beam current limiter input
BLKIN	50	black current input / V-guard input
RO	51	Red output
GO	52	Green output
BO	53	Blue output
VDDA	54	analog supply of Teletext decoder and digital supply of TV-processor (3.3 V)
VPE	55	OTP Programming Voltage
VDDC	56	digital supply to core (3.3 V)
OSCGND	57	oscillator ground supply
XTALIN	58	crystal oscillator input
XTALOUT	59	crystal oscillator output
RESET	60	reset
VDDP	61	digital supply to periphery (+3.3 V)
P1.0/INT1	62	port 1.0 or external interrupt 1 input
P1.1/T0	63	port 1.1 or Counter/Timer 0 input
P1.2/INT0	64	port 1.2 or external interrupt 0 input
P1.3/T1	1	port 1.3 or Counter/Timer 1 input
P1.6/SCL	2	port 1.6 or I ² C-bus clock line
P1.7/SDA	3	port 1.7 or I ² C-bus data line
P2.0/TPWM	4	port 2.0 or Tuning PWM output
P3.0/ADC0/PWM0	5	port 3.0 or ADC0 input or PWM0 output

2. TFA9842AJ

2-channel audio amplifier with volume control (SE: 1 W to 7.5 W)

2.1 General description

The TFA9842AJ contains two identical audio power amplifiers. The TFA9842AJ can be used as two Single-Ended (SE) channels with a volume control. The maximum gain is 26 dB.

The TFA9842AJ comes in a 9-pin DIL-bent-SIL (DBS9P) power package. The TFA9842AJ is pin compatible with the TFA9843AJ, TFA9843(B)J, TFA9842(B)J and TFA9841J. The difference between the TFA9843AJ and the TFA9843(B)J, TFA9842(B)J, TFA9841J is the functionality of pin 7. The TFA9843AJ has a Volume Control (VC) on pin 7. The TFA9843(B)J, TFA9842(B)J and TFA9841 J have a mode select (Mode) on pin 7. The TFA9842AJ contains a unique protection circuit that is solely based on multiple temperature measurements inside the chip. This gives maximum output power for all supply voltages and load conditions with no unnecessary audio holes. Almost any supply voltage and load impedance combination can be made as long as thermal boundary conditions (number of channels used, external heatsink and ambient temperature) allow it.

2.2 Features

- ✍ 2 Channel SE: 1 W to 7.5 W operation possibility
- ✍ Soft clipping
- ✍ Input clamps
- ✍ Volume control
- ✍ Standby and mute mode
- ✍ No on/off switching plops
- ✍ Low standby current
- ✍ High supply voltage ripple rejection
- ✍ Outputs short-circuit protected to ground, supply and across the load
- ✍ Thermally protected
- ✍ Pin compatible with the TFA9843AJ, TFA9843(B)J, TFA9842(B)J, TFA9841J.

2.3 Block diagram of TFA9842AJ

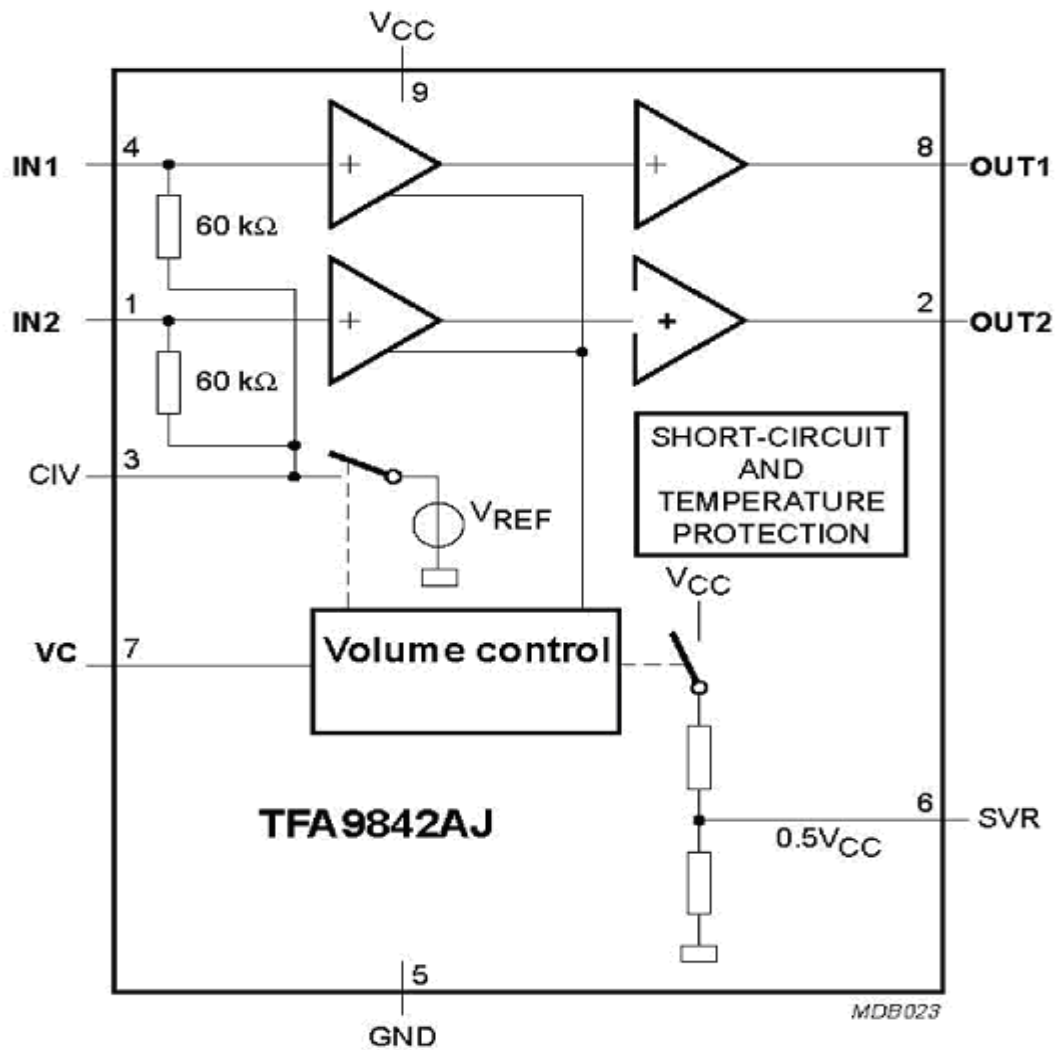

Fig. 6

2.4 Pinning

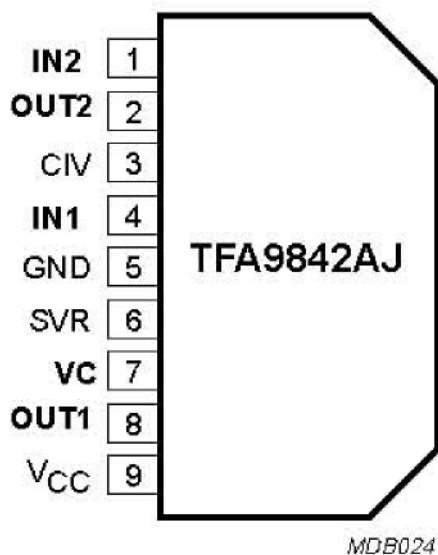

Fig.7

2.5 Pin description

Table 8

Symbol	Pin	Description
IN2	1	input 2
OUT2	2	loudspeaker terminal 2
CIV	3	common input voltage decoupling
IN1	4	input 1
GND	5	ground
SVR	6	half supply voltage decoupling (ripple rejection)
VC	7	volume control input (standby, mute and volume control)
OUT1	8	loudspeaker terminal 1
V _{CC}	9	supply voltage

3. VERTICAL SCAN OUTPUT STAGE CIRCUIT TDA4863AJ/TDA4864AJ

3.1 FEATURES

TDA4863AJ: Output current up to 3 A (p-p)

TDA4864AJ: Output current up to 2.5A (p-p)

3.2 GENERAL DESCRIPTION

The TDA4863AJ and TDA4864AJ are deflection boosters for use in vertical deflection systems for frame frequencies up to 200 Hz.

The TDA4863AJ or TDA4864AJ needs a separate flyback supply voltage, so the supply voltages are independently adjustable to optimize power consumption and flyback time.

For the TDA4863AJ or TA4864AJ the flyback supply voltage will be generated internally by doubling the supply voltage and therefore a separate flyback supply voltage is not needed.

3.3 Block diagram of TDA4863AJ and TDA4864AJ

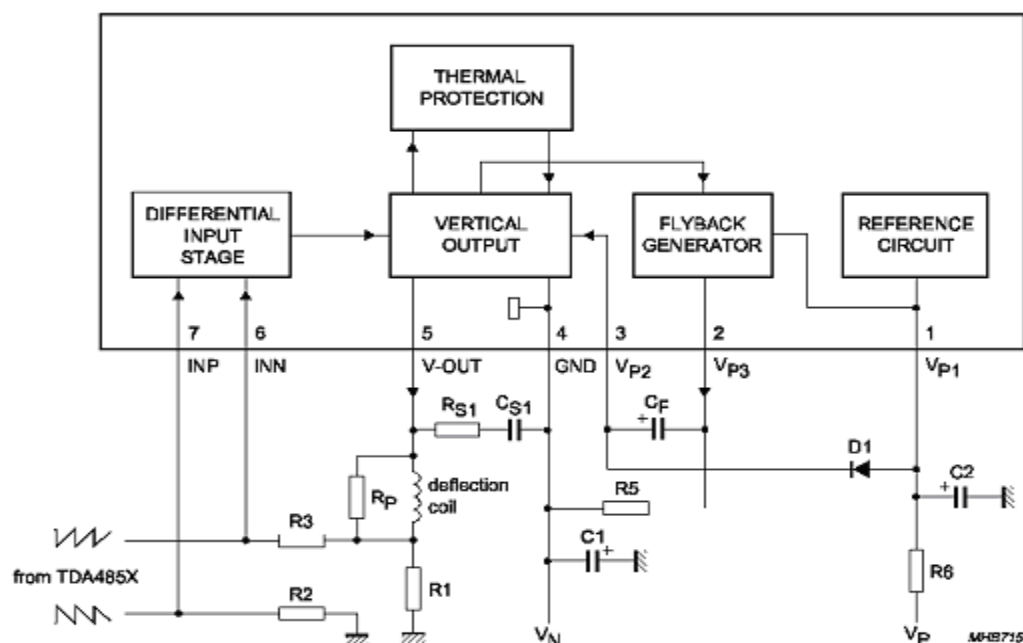

Fig.7

3.4 pinning

Table 9

SYMBOL	TDA4863AJ	DESCRIPTION
	TDA4864AJ	
VP1	1	positive supply voltage 1
VP3	2	flyback generator output
VP2	3	supply voltage 2 for vertical output
GND	4	ground or negative supply voltage
V-OUT	5	vertical output
INN	6	inverted input of differential input stage
INP	7	non-inverted input of differential input stage

4. EEPROM AT24CXX

4.1 Features

Low-voltage and Standard-voltage Operation

-2.7 (V_{cc}=2.7V to 5.5V) -1.8 (V_{cc}=1.8V to 5.5V)

Internally Organized 128x8(1 K), 256x8 (2K), 512x8 (4K),
1024x8 (8K) or 2048x8 (16K)

2-wire Serial Interface

Schmitt Trigger, Filtered Inputs for Noise Suppression

Bi-directional Data Transfer Protocol

100kHz (1.8V, 2.5V, 2.7V) and 400 kHz (5V) Compatibility

Write Protect Pin for Hardware Data Protection

8-byte Page (1K, 2K), 16-byte Page (4K, 8K, 16K) Write Modes

Partial Page Writes are Allowed

Self-timed Write Cycle (10 ms max)

High-reliability

- Endurance: 1 Million Write Cycles

- Data Retention: 100 Years

Automotive Grade and Extended Temperature Devices Available

8-lead PDIP, 8-lead JEDEC SOIC, 8-lead MAP and 8-lead TSSOP Package

2-wire

Serial EEPROM

Table 10

AT24C01A 1K (128 x 8)

AT24C02 2K (256 x 8)

AT24C04 4K (512 x 8)

AT24C08 8K (1024 x 8)

AT24C16 16K (2048 x 8)

4.2 Description

The AT24C01A/02/04/08/16 provides 1024/2048/4096/8192/16384 bits of serial electrically erasable and programmable read-only memory (EEPROM) organized as 128/256/512/1024/2048 words of 8 bits each. The device is optimized for use in many industrial and commercial applications where low-power and low-voltage operations are essential. The AT24C01A/02/04/08/16 is available in space-saving 8-pin PDIP, 8-lead JEDEC SOIC, 8-lead MAP and 8-lead TSSOP packages and is accessed via a 2-wire serial interface. In addition, the entire family is available in 2.7V (2.7V to 5.5V) and 1.8V (1.8V to 5.5V) versions.

4.3 Pin Configuration

Table 11

Pin Name	Function
A0-A2	Address Inputs
SDA	Serial Data
SCL	Serial Clock Input
WP	Write Protect
NC	No Connect

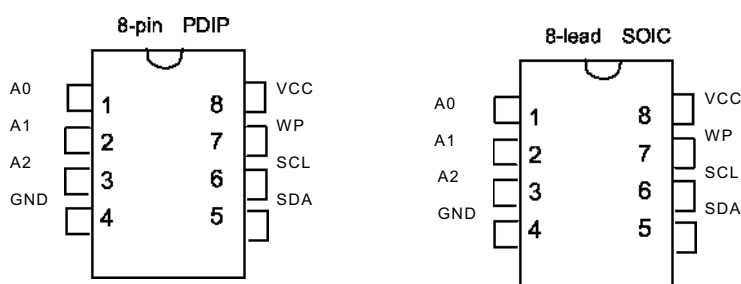
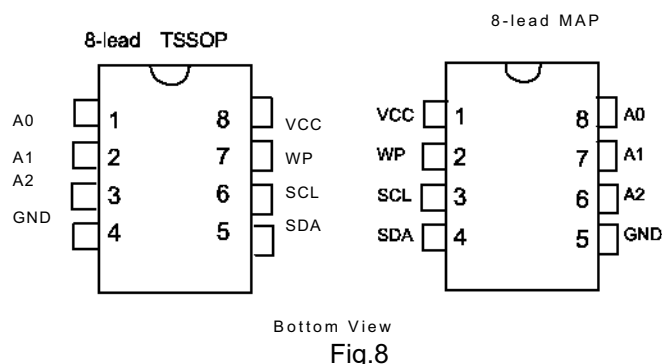

Fig.9

4.4 Pin Description

SERIAL CLOCK (SCL): The SCL input is used to positive edge clock data into each EEPROM device and negative edge clock data out of each device.

SERIAL DATA (SDA): The SDA pin is bi-directional for serial data transfer. This pin is open-drain driven and may be wire-ORed with any number of other open-drain or open-collector devices.

DEVICE/PAGE ADDRESSES (A2, A1, A0): The A2, A1 and A0 pins are device address inputs that are hard wired for the AT24C01A and the AT24C02. As many as eight 1K/2K devices may be addressed on a single bus system (device addressing is discussed in detail under the Device Addressing section).

The AT24C04 uses the A2 and A1 inputs for hard wire addressing and a total of four 4K devices may be addressed on a single bus system. The A0 pin is a no connect.

The AT24C08 only uses the A2 input for hardwire addressing and a total of two 8K devices may be addressed on a single bus system. The A0 and A1 pins are no connects.

The AT24C16 does not use the device address pins, which limits the number of devices on a single bus to one. The A0, A1 and A2 pins are no connects.

WRITE PROTECT (WP): The AT24C01A/02/04/16 has a Write Protect pin that provides hardware data

protection. The Write Protect pin allows normal read/write operations when connected to ground (GND). When the Write Protect pin is connected to Vcc, the write protection feature is enabled and operates as shown in table 12.

Table 12

WP Pin Status	Part of the Array Protected				
	24C01A	24C02	24C04	24C08	24C16
At Vcc	Full (1 K) Array	Full (2K) Array	Full (4K) Array	Normal Read/Write Operation	Upper Half (8K) Array
At GND	Normal Read/Write Operations				

4.5 Memory Organization

AT24C01A, 1K SERIAL EEPROM: Internally organized with 16 pages of 8 bytes each, the 1K requires a 7-bit data word address for random word addressing.

AT24C02, 2K SERIAL EEPROM: Internally organized with 32 pages of 8 bytes each, the 2K requires an 8-bit data word address for random word addressing.

AT24C04, 4K SERIAL EEPROM: Internally organized with 32 pages of 16 bytes each, the 4K requires a 9-bit data word address for random word addressing.

AT24C08, 8K SERIAL EEPROM: Internally organized with 64 pages of 16 bytes each, the 8K requires a 10-bit data word address for random word addressing.

AT24C16, 16K SERIAL EEPROM: Internally organized with 128 pages of 16 bytes each, the 16K requires an 11-bit data word address for random word addressing.

4.6 Block Diagram

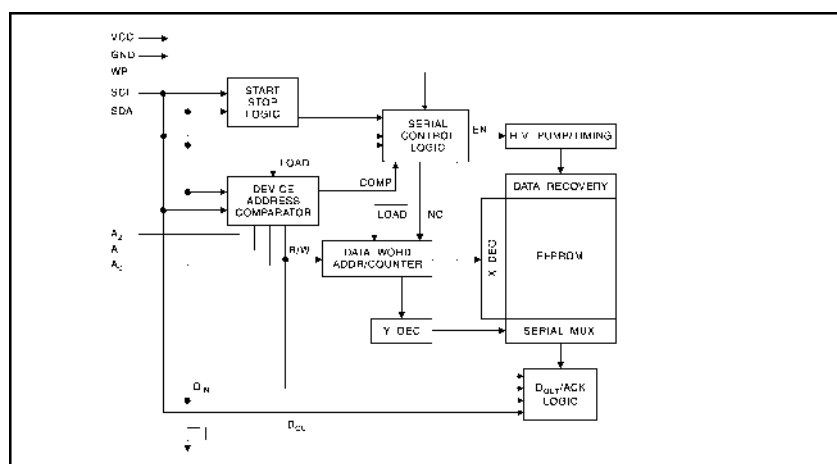

Fig.10

4.7 Refer to Table 21 about Functions and Data of the IC's Pins.

5. SWITCH-MODE POWER SUPPLY IC STRG5653/G8656

5.1 General Description

The STRG5653/G8656 are part of the STRG5600/G8600 series thick-film ICs for switch-mode power supply incorporating power MOSFET with a high-precise error amplifier. The ICs feature fewer external components, small-size and standard power supply.

The series STR-G8600 use Chip on Chip technology with the same operation principle as STR-G5600. Pin

configuration,

function

and

threshold

of

STR-G8600

are

compatible

with

those

of

STR-G5600.

5.2 Block Diagram

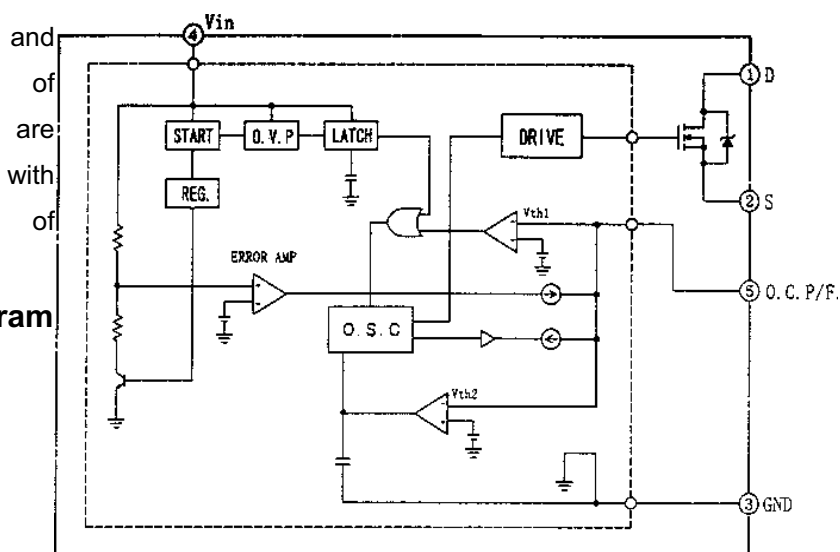
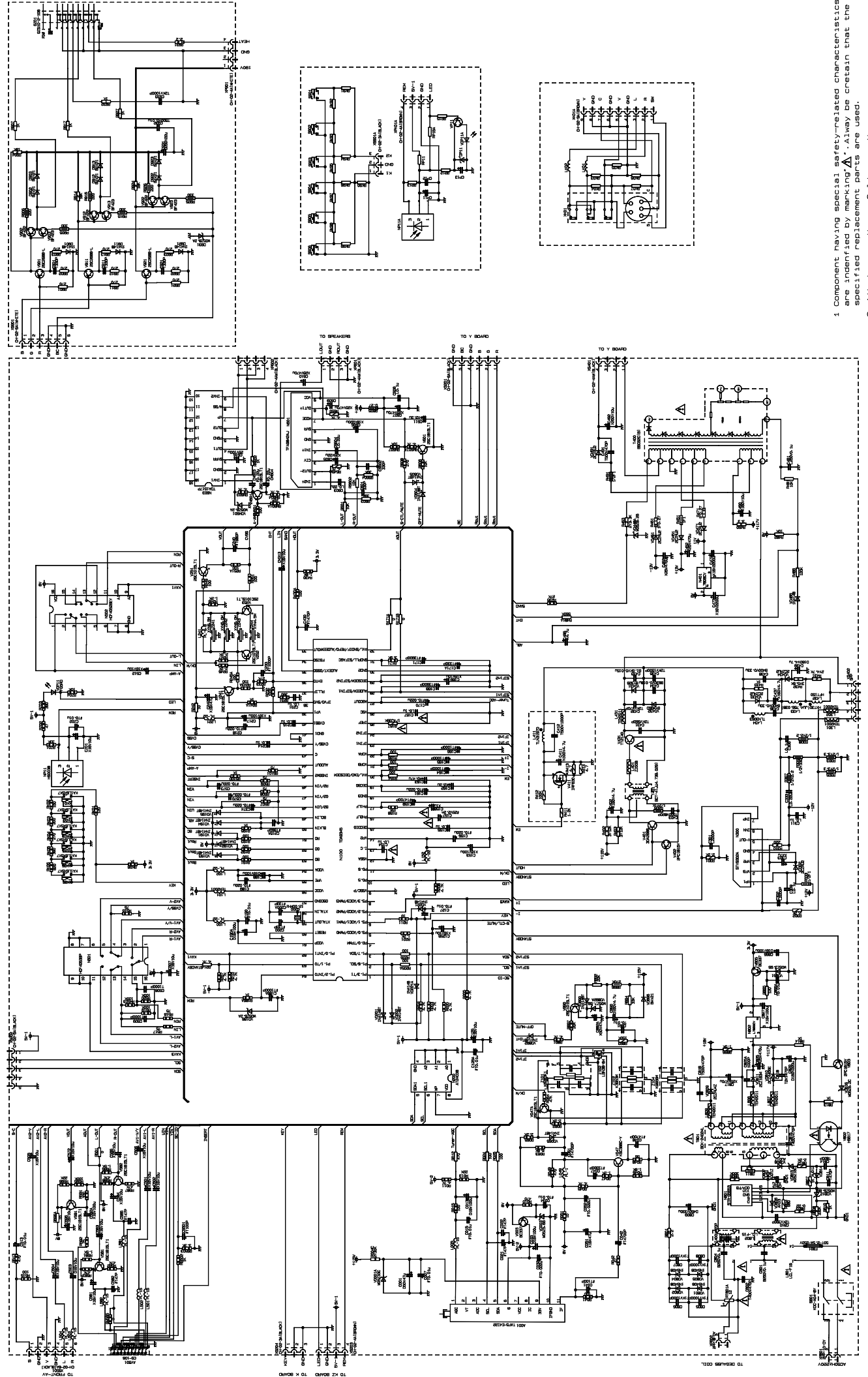

Fig. 11

5.3 Function of Terminal Table 15 Function of Terminal

Terminal No.	Symbols	Description	Functions
1	D	Drain Terminal	MOS FET drain
2	S	Source Terminal	MOS FET source
3	GND	Ground Terminal	Ground
4	VIN	Power supply Terminal	Input of power supply for control signals
5	O.C.P/F.B	Overcurrent/Feedback Terminal	Input of overcurrent detection signal and constant voltage signals



- 1 Component having special safety-related characteristics are identified by marking Δ . Always be certain that the specified replacement parts are used.
- 2 Δ Heat grounding #Coid grounding
- 3 See replacement part list for components specifications.

REV.	DATE	BY	CHKD.	DESCRIPTION
1				
2				
3				
4				
5				
6				
7				
8				
9				
10				

This circuit diagram is only for reference. Specifications are subject to change without notice.

CIRCUIT DIAGRAM OF ETE-2

Main parts list

CTV-55SF50 TXT

Part	Type	Position	Remarks
Resistance	MZ73-9RM	RT801A	
capacitance	CD288-160V-220 μ FM(ϕ 18X35)	C820	
capacitance	CD293-450V-220 μ FM	C809	
Diode	MUR460RLG	VD810	
Diode	BY328	VD431	
Diode	BYW96D	VD432	
photovoltaic coupling	HS817	V802	optional
	HPC922		
	HS817C		
	TCET1106		
	TCET1103		
Crystal oscillator	JA18A-12.000MHZ	G200	
Transformer	BCT-27	T401	
fuze	R/S/V/I50TT2.5AL250V	F801	optional
	61802.5		
IC	AT24C08	N200	optional
	AT24C08A-10PU2.7		
IC	HCF4053BEY	N501	optional
	HEF4053BP		
	HCF4053BP		
IC	TDA9353PS/N3/3	N100	
TUNER	TAF5-E4I22	A001	
IC	HCF4052BEY	N502	optional
	HEF4052BP		
Transformer	BCK-24024L	T801	
	HXT27	L433	
	HFT50	L432	
	BSC62C(B)	T400	
	GZS10-2-AC2	GZ01	optional
	GZS10-2-108		
	HRM380017	NP11A	optional
	HS0038A2		
	AT138A		
Triode	3DD1557	V431	
IC	TDA4863AJ/V1	N300	
	FQPF10N20C	V411	optional
IRF630FP			
IC	TFA9842AJ/N1	N601	
	L7805CV	N802	optional
	KA7805TU		
	MC7805CT		
	CW7805CS		
	AZ7805T	N401	optional
	L7808CV		
	KA7808TU		
MC7808CT			
	CW7808CS	N801	
	AZ7808T		
IC	STR-G5653	N801	
	XC-21F2(B)		optional
	XC-21F2		
IC	2SC388ATM	V047	optional
	KSC388C-Y		
	Super Slim		
	Remote control		
Front cover assembly			
Back cover assembly			
Speaker			
Gift box			