Polar Instruments Ltd.

Toneohm 970 Service Manual

Polar Instruments Ltd.
Garenne Park
St. Sampson
Guernsey
Channel Islands
GY2 4AF
ENGLAND
<http://www.polar.co.uk>

Fax: +44 (0)1481 252476
Email: mail@polar.co.uk

MAN177-9910

TONEOHM 970 SERVICE MANUAL

POLAR INSTRUMENTS LTD. HARDWARE WARRANTY

Product Warranty. Product hardware is warranted to be free from defects in material and workmanship during the Warranty Period (as defined below). Product hardware is warranted to conform substantially to Polar's then current (as of the date of Polar's product shipment) published user documentation during the Warranty Period. The Warranty Period is twelve (12) months. Product support beyond these periods may be available at additional cost – consult Polar for details.

Warranty Claims. Polar shall incur no liability under this warranty if the end user fails to provide Polar with notice of the alleged defect during the applicable Warranty Period and within seven (7) days of delivery to end user or, if the defect would not have been reasonably apparent on inspection, within seven (7) days of its discovery by end user. After receiving such notice, Polar will notify the purchaser of its designation of one of the following problem resolution methods:

Return to Factory. The allegedly defective goods must be returned to Polar within seven days of Polar's notice and in accordance with Polar's instructions advised at the time.

Other: Polar will use commercially reasonable efforts to repair, correct or work around the problem by means of telephone support or other means reasonably determined by Polar.

Polar shall incur no liability under this warranty if Polar's tests disclose that the alleged defect is due to causes not within Polar's reasonable control, including alteration or abuse of the goods. Under the *Return to Factory* alternative, if a Product is determined not to be defective or to have a defect due to causes not within Polar's reasonable control, Polar reserves the right to apply a processing charge.

Damage in Transit. End user must notify Polar and the carrier of any claim for damage in transit within two (2) days of receipt of the damaged merchandise. Failure to do so may result in the carrier and/or Polar refusing to accept liability in which case end user must pay the purchase price as if the hardware had been delivered without damage.

Polar's Liability Polar's liability, and end user's sole and exclusive remedy, shall be limited to the express remedies set forth in this Polar Hardware Warranty.

Disclaimer of Warranties. POLAR MAKES NO OTHER WARRANTIES, EXPRESS, IMPLIED OR STATUTORY, REGARDING PRODUCTS. ALL OTHER WARRANTIES AS TO THE QUALITY, CONDITION, MERCHANTABILITY, FITNESS FOR A PARTICULAR PURPOSE, OR NON-INFRINGEMENT ARE EXPRESSLY DISCLAIMED.

Limitation of Liability. POLAR SHALL NOT BE RESPONSIBLE FOR DIRECT DAMAGES IN EXCESS OF THE PURCHASE PRICE PAID BY THE END USER OR FOR ANY SPECIAL, CONSEQUENTIAL, INCIDENTAL, OR PUNITIVE DAMAGE, INCLUDING, BUT NOT LIMITED TO, LOSS OF PROFITS OR DAMAGES TO BUSINESS OR BUSINESS RELATIONS, WHETHER OR NOT ADVISED IN ADVANCE OF THE POSSIBILITY OF SUCH DAMAGES, THE FOREGOING LIMITATIONS SHALL APPLY, NOTWITHSTANDING THE FAILURE OF ANY EXCLUSIVE REMEDIES.

DECLARATIONS

European Community Directive Conformance Statement

Refer to the Operator Manual to determine conformance with European Community Directives.

SAFETY

WARNING *The service instructions contained in this manual are for use by qualified electronic service personnel only.*

WARNING

The LIVE and NEUTRAL lines on this unit are BOTH fused.

When the unit is connected to its supply, the opening of covers or removal of panels is likely to expose dangerous voltages.

GROUNDING

This unit must be earthed (grounded); do not operate the instrument with the safety earth disconnected. Ensure the instrument is connected to an outlet with an effective protective conductor terminal (earth). Do not negate this protective action by using an extension cord without a protective conductor.

Note: This instrument is fitted with 3-wire grounding type plug designed to fit only into a grounding type power outlet. If a special local plug must be fitted to the power cord ensure this operation is performed by a skilled electronics technician and that the protective ground connection is maintained. The plug that is cut off from the power cord must be safely disposed of.

Power cord color codes are as follows:

Europe

brown live
blue neutral
green/yellow earth (ground)

United States

black live
white neutral
green ground

POWER SUPPLY

Check that the indicated line voltage setting corresponds with the local mains power supply. See the rear panel for line voltage settings. Instruments with a serial number prefixed with a letter (e.g. A1234) are configured for 90 – 110 Volts only.

Changing the line voltage settings on this instrument must only be performed by a skilled electronics technician. Instructions for changing the line voltage settings are contained in Section 5.

OPERATION

This manual contains instructions and warnings which must be observed by the user to ensure safe operation. Operating this instrument in ways other than detailed in this manual may impair the protection provided by the instrument and may result in the instrument becoming unsafe. Retain these instructions for later use.

The unit is designed for use indoors in an electrical workshop environment at a stable work station comprising a bench or similar work surface.

Use only the accessories (e.g. test probes and clips) provided by Polar Instruments.

The instrument must be maintained and repaired by a skilled electronics technician in accordance with the manufacturer's instructions.

If it is likely that the protection has been impaired the instrument must be made inoperative, secured against unintended operation and referred to qualified service personnel.

Protection may be impaired if, for example, the instrument:

- Shows signs of physical damage
- Fails to operate normally when the operating instructions are followed
- Has been stored for prolonged periods under unfavourable conditions
- Has been subjected to excessive transport stresses
- Has been exposed to rain or water or been subject to liquid spills

CAUTION

Electrical Isolation

Always disconnect the board under test from the local mains supply (including ground) before using this instrument.

Static Sensitive Devices

This unit contains Static Sensitive Devices. Static discharge can damage some electronic components. Care must be taken when handling these components. Observe appropriate precautions to avoid damage.

SPECIFICATIONS

Track Shorts

RANGES	Five Ranges with approximate FSD values of 40mΩ, 200mΩ, 2Ω, 20Ω, and 200Ω.
PROBE VOLTAGE	60mV maximum.
INDICATION	Tone and meter in all ranges.
PROBE PROTECTION	Momentary contact up to 30V.

Plane Shorts

INDICATION	Tone, uncalibrated meter and fault direction arrows.
SENSITIVITY	Adjustable for differing plane resistance. Capable of detecting shorts up to 20Ω.

Plane Stimulus

OUTPUT VOLTAGE	550mV maximum. Active only when PLANE SHORTS is ACTIVE and outputs are connected to a plane.
OUTPUT CURRENT	700mA RMS maximum.
PROTECTION	Each output separately fused (5A Fast).

Drive Level

OUTPUT VOLTAGE	0 to 550mV, adjustable..
PROTECTION	Protected to ± 30V.

ENVIRONMENTAL OPERATING CONDITIONS

The instrument is designed for indoor use only under the following environmental conditions:

Altitude	Up to 2000m
Temperature	+5°C to +40°C ambient
Relative humidity	RH 80% maximum at 31°C — derate linearly to 50% at 40°C
Mains borne transients	As defined by Installation Category II (Overvoltage Category II) in IEC664
Pollution Degree	2 (IEC664)

Power requirements

230V \pm 10%, 115V \pm 10% or 100V \pm 10% at 50/60Hz, 25VA.

Fuses

230V	125mAT
115V	250mAT

Physical characteristics (excluding accessories)

Dimensions	305mm (12 in.) wide. 150mm (5.9 in.) high. 275mm (10.8 in.) deep.
Weight	3.5 kg.
Flammability	Enclosure to UL94 V-0.

SYMBOLS



REFER TO MANUAL

These sockets are for connecting only Polar Instruments probes and connectors for use as described in the Operator Manual. To prevent damage to this product and to ensure its safe use observe the specifications given in this manual when connecting to terminals marked with this symbol.

ACCESSORIES

Standard Accessories

Needle Probes	ACC152
970 Plane Probe/Clip assembly	ACC113
970 Current Trace Probe assembly	ACC114
970 Stimulus Lead (Set of 4)	ACC134
Bare board lead set	ACC231
Lightweight Headphones	EPM115

CONTENTS

DECLARATIONS	i
European Community Directive Conformance Statement	i
SAFETY	ii
WARNING	ii
GROUNDING	ii
POWER SUPPLY	ii
OPERATION	iii
CAUTION	iii
SPECIFICATIONS	iv
ENVIRONMENTAL OPERATING CONDITIONS	iv
Power requirements.....	v
Fuses.....	v
Physical characteristics (excluding accessories)	v
SYMBOLS	v
ACCESSORIES	v
Standard Accessories.....	v
CONTENTS.....	vii
PERFORMANCE CHECKING	1
Maintenance and calibration of instruments	1
Performance check	1
Adjustment procedure	1
Recommendations for routine maintenance.....	1
TONEOHM 970 PERFORMANCE CHECK	3
Equipment required	3
Procedure.....	3
ADJUSTMENT PROCEDURE	5
Equipment required	5
Display calibration	5
Resistance calibration	5
Current Trace	6
Plane Shorts.....	6
CIRCUIT DESCRIPTION	7
TONEOHM 970 THEORY OF OPERATION	7
MAIN OPERATING MODES	8
Track shorts.....	8
Trace	8
Plane Shorts.....	8
DETAILED THEORY OF OPERATION	9
Microvolt Amplifier	9
Trace Amplifier	9
Current Source	9
Plane Amplifier and Vector Discriminator	10

Vectored Plane Stimulus	11
Drive Source.....	12
Tone Generator	12
Power Supply.....	12
Microprocessor	13
Front Panel	13
DISMANTLING INSTRUCTIONS	15
LINE VOLTAGE AND FUSE CHANGING	17
Changing the line voltage setting.....	17
FAULT DIAGNOSIS	19
Troubleshooting hints	19
MAINTENANCE AND CLEANING	21
Cleaning	21
Technical support	21
Instrument repair.....	21
REPLACEMENT PARTS	23
FRONT PANEL KIT	24
MAIN BOARD KIT	25
MECHANICAL KIT.....	29
SCHEMATIC DIAGRAMS	31

PERFORMANCE CHECKING

Maintenance and calibration of instruments

For most of Polar Instruments' products there are two maintenance procedures — the **Performance Check** and the **Calibration**. Some instruments may have a single (combined) procedure.

Performance check

The Performance Check (or Checkout Procedure) is used to verify the basic functions of the instrument. This does not usually require the removal of instrument covers, but may require the use of external test equipment. This procedure is not intended to verify the calibration of the instrument.

Adjustment procedure

The Adjustment Procedure (or Calibration Procedure) is used to check and, if necessary, adjust the instrument's calibration settings. Before carrying out the Adjustment Procedure the instrument's Performance Check (if applicable) should be carried out, and any detected defects should be rectified. *The Adjustment Procedure and rectification of defects should only be carried out by qualified technician.*

Recommendations for routine maintenance

Where a Performance Check is available for an instrument this may be used as required to confirm the basic operation of the product.

To maintain the calibration of an instrument it is recommended that its Calibration/Adjustment Procedure is carried out at intervals not exceeding 12 months.

TONEOHM 970 PERFORMANCE CHECK

Equipment required

DC voltage source, variable from 1V to 10V and accurate to 0.1%.

High tolerance resistors (0.5%) of the following values: 10K Ω , 200 Ω , 100 Ω , 10 Ω , 1 Ω and 0.1 Ω .

Procedure

Switch on and allow the 970 to warm up for 20 minutes.

1. Plug in the Needle Probes and press and hold any key. Turn the power off then on again and release the key.
2. Connect a 1K Ω 0.5% and a 1 Ω 0.5% resistor in series.
3. Apply 10V to the series resistors. This produces 10mV across the 1 Ω Resistor.
4. Apply 10mV DC to the probes and check that the reading is 100 ± 4 counts
5. Press LOW Track Shorts and measure a 100 Ω 0.5% resistor. The reading should be 1000 ± 40 . A warble may be generated in this range.
6. Press next to lowest Track Shorts range and measure a 10 Ω 0.1% resistor. The reading should be 1000 ± 40 .
7. Press The middle Track shorts range and measure a 1 Ω 0.1% resistor. The reading should be 1000 ± 40 .
8. Apply solder to the wire ends of a 100m Ω 0.5% resistor.
9. Press the next to highest Track Shorts range and measure the resistor by pressing the probe tips into the solder. The reading should be within 1000

- ± 40 . Readings vary with the pressure applied to the probes.
10. Press CURRENT TRACE and connect the Drive Source leads across a 200Ω resistor. Turn the DRIVE LEVEL knob fully clockwise.
 11. Hold the Current Trace Probe tip near to one of the Drive Source leads and align it for maximum response.
 12. Check that the display shows 20 or more.
 13. Connect the Blue and Yellow Stimulus lead together. Press PLANE SHORTS twice — check for the warning bell and that the instrument returns to Standby. Leave leads connected.
 14. Connect the Red and Green Stimulus lead together. Press PLANE SHORTS once. Check for ACTIVE LED.
 15. Connect the red and black Drive Source leads across a 0.1Ω resistor. Attach the Plane Clip to the black Drive Source lead. Probe the other end of the resistor with the probe.
 16. Slowly turn the DRIVE LEVEL minimum to maximum (i.e. clockwise). As the control is rotated, check that initially all direction arrow LEDs are on, then the upper LED only, then all LEDs are off. At the same time the tone goes from high to low then off.
 17. Reverse the connections to the Plane Probe and Clip. Rotate DRIVE LEVEL from maximum to minimum (i.e. anti-clockwise). As the control is rotated, check initially for no arrows or tone, then rising tone and bottom arrow on, finally all arrows on.
 18. Disconnect the Red and Green Stimulus lead. PLANE should automatically ring warning bell and return to standby. Disconnect the Plane Probe and Clip from the 0.1Ω resistor.
 19. Disconnect all cables.

ADJUSTMENT PROCEDURE

WARNING: Hazardous voltages are exposed on the PCB when the cover is removed. This procedure should only be performed by a technically qualified person aware of the hazards and taking all reasonable care.

Equipment required

High tolerance(0.1%) voltage source — 10V and 10mv.

High tolerance(0.1%) 1 Ω and 100m Ω resistors.

DVM

Power Supply.

Before connecting to the supply:—

1. CHECK THE MAINS FUSES — see SPECIFICATIONS.
2. Connect the 970 to the appropriate line voltage and turn on.
3. CHECK the front panel lights sequence and that the 970 stops in the PLANE STANDBY range.
4. Hold any key down and turn power off, then on. Release key.

Display calibration

1. Plug in and connect the Needle Probes to the 10mV source.
2. Adjust POT R196 (top RHS of Front Panel board) for a display of 1000

Resistance calibration

1. SELECT the Middle TRACK SHORTS range.
Place the probes across the 1 Ω resistor. ADJUST R713 for 1000 reading \pm 3 Counts.

Current Trace

1. Connect Trace / Drive Source Probe.
2. Push CURRENT TRACE. Adjust the volume as desired, short the drive source leads together and turn the drive source to MAXimum.
3. While holding the probe against the Drive Source lead ADJUST R94 for the highest displayed reading (> 500).
Move the probe away from the Drive Source leads,
4. CHECK Tone turns off and displayed reading is less than 25.

Plane Shorts

1. CONNECT the 4 Plane Stimulus leads BLUE to YELLOW and RED to GREEN
2. Push PLANE SHORTS twice to enter ACTIVE mode.
3. CONNECT the Plane Clip to the Plane Probe.
Adjust R85 for a reading of 00.0 ± 3 counts.

Adjust R716 (located near U18, behind copper shield) for minimum (or most negative) reading.
Re-adjust R85 for 00.0 ± 3 counts.
4. Reduce the Variac to:
190V (240V instruments)
95V (120V instruments)
85V (Japanese instruments)
Check that PLANE remains ACTIVE
5. Remove the Green clip from the demo board and check the 970 goes to standby. Reconnect the clip and select ACTIVE.
6. Repeat for the yellow clip.
7. Disconnect all probes.

CIRCUIT DESCRIPTION

TONEOHM 970 THEORY OF OPERATION

The TONEOHM 970 consists of the following functional blocks:

- | | |
|---|---|
| 1. Microvolt Amplifier | Amplifies track voltages, and is used in conjunction with the internal current source for the calculation of track resistance. |
| 2. Trace Amplifier | Amplifies and rectifies the low level AC signal from the Trace probe to provide a DC voltage output proportional to magnetic field. |
| 3. Current source | Provides a range of currents for resistance measurement. |
| 4. Plane Amplifier and Vector discriminator | Amplifies low level plane signals, separates vector and magnitude components. |
| 5. Vectored Plane Stimulus | Provides the four vectored signals for Plane Shorts mode. |
| 6. Drive Source | User adjustable constant current AC supply for non-contact current tracing. |
| 7. Tone Generator | Voltage controlled oscillator which provides varying tone proportional to meter reading. |

8. Power Supply	± 5V analog and digital supplies. 12/5V floating supply for drive source. 4V a.c. supply for vectored plane stimulus.
9. Microprocessor	Controls hardware and performs current calculation.
10. Front Panel	Keyboard and display D–A.

MAIN OPERATING MODES

Track shorts

Current is injected into the track with the needle probes using the CURRENT SOURCE module, the μ V AMPLIFIER conditions the resulting track voltage and displays the result directly on the LCD.

Trace

In TRACE mode the 970 uses an inductive pick up to detect an a.c. current in a faulty track. The a.c. current is supplied from the DRIVE SOURCE leads; the detected signal is conditioned by the TRACE amplifier and then switched to the LCD and TONE GENERATOR by U25 (sheet 6) and U59 (sheet 1) respectively.

Plane Shorts

In PLANE SHORTS mode the 970 uses VECTORED PLANE STIMULUS to set up a field pattern on the plane under test, the Plane Clip references the short to ground and the voltage measured on the Plane Probe is an a.c. signal providing both magnitude and position information. The PLANE AMPLIFIER and VECTOR DISCRIMINATOR resolve this into a magnitude signal (sent to the LCD and TONE GENERATOR and a vector signal for the 4 direction arrows on the front panel).

DETAILED THEORY OF OPERATION

Microvolt Amplifier

JP11 is the input connection from the probe sockets. Relays K1, 2 and 3 provide $\div 1$, $\div 10$ and $\div 1000$ attenuation setting for the main Amplifier U1.

U1 is a low offset voltage chopper stabilised amplifier with gains of x10 or x100 (selected by the analog switch U24 on the Tone Generator schematic). The network on the output of U1 provides an idealised response for the tone generator. "HI" and "LO" are the calibrated outputs to the front panel meter (via analog switch U25 on sheet 6).

U59 and associated components provide a second nonlinear amplifier for use in TRACE and PLANE modes

Trace Amplifier

Refer to Microvolt Amplifier schematic.

The DRIVE Source provides PCB tracks with an 80kHz (approximately) current; this is detected by the Trace Probe. The low level signal is first amplified and filtered by U2B, further amplification and conditioning is provided by nonlinear amplifier U2A, the a.c. signal is then rectified and smoothed by active rectifier U2D; after buffering and attenuation U25 (A–D Converter schematic) directs the output to the front panel meter.

Current Source

Refer to A–D Converter schematic

The current source provides a range of known d.c. currents for resistance measurement.

The loop formed by U5A, U62A, Q2, D13 and associated components provide a low impedance 56mV or 0.56V (approximately) source. The microprocessor is both able to select the voltage via U24 on the Tone Generator schematic, or gate the supply via Q2 and U62B. Q2 and D13 also afford protection against inadvertently connecting high voltages to the probes.

The voltage is applied via relays R1 to R7 across a series resistance and via the Kelvin connected Needle Probes, to provide a known current through the track resistance under test.

In order to correct for offsets caused in the needle probes when measuring low resistances, U4 and associated components apply offset to the μV Amplifier in order to

achieve a zero reading in the middle and next to high ranges; in the HIGH range offset is applied to give a stable reading but a zero is not achieved when the probes are shorted.

Plane Amplifier and Vector Discriminator

Refer to Plane Input Amplifier Schematic

The Vectored Plane Stimulus sets up a field on the plane under test such that when the plane is probed the following waveforms are detected:

above the short	two positive going half sine waves
below the short	two negative going half sine waves
left of the short	a positive followed by a negative half sine wave
right of the short	a negative followed by a positive half sine wave

The magnitude of the half waves detected increases with increasing distance from the short.

The 970 extracts this information as follows:

U12 Amplifies the low level signal from the Plane Probe; this chopper-stabilised amplifier is clocked by a signal synchronous with the Vectored Stimulus to minimise clock noise on the a.c. output signal. JP12 connects to the Drive Source/Sensitivity control to allow user adjustment of sensitivity.

U6 forms an active rectifier for the incoming signal which is taken to sample-and-hold gate U8, along with the unrectified component. U8 is clocked and gated so that the peak amplitudes of each halfwave in both rectified and unrectified form are sampled and held on C11, C12, C13 and C16. Magnitude signals on C11 and C12 are added then switched via U25 (A–D Converter schematic) and U59 (Microvolt Amplifier schematic) to the LCD and TONE GENERATOR respectively.

C13 and C16 hold the unrectified component of the plane signal; here only their polarities are of interest, these are detected and converted to TTL levels by comparators U10 and U14 the two resultant signals (QUADRANT0 and

QUADRANT1) are taken to the front panel and decoded to illuminate the appropriate direction arrow.

Finally U17A and B monitor the level of PLANEV+ and through the control signals ARROW OFF and CENTRE...

1. Turn the arrows off when the probes are open circuit.
2. Allow the QUADRANT signals to control the arrow when the plane is being probed.
3. Turn all the arrows on when the probe is a few centimetres from the short.

Vectored Plane Stimulus

Refer to Drive Source schematic

The stimulus runs at power line frequency and provides a nominal 2A (peak) current from top left to bottom right of the plane during the first 180 degrees of the line signal followed by the same signal from top right to bottom left during the second 180 degrees.

The two halves of the stimulus circuit are identical except for the phase of the inputs which allow the steering diodes (D31, D32, D73, D35) to pass current on alternate half cycles. Relay K14 allows the microprocessor to turn the stimulus off and on.

Taking the top circuit as the example, +2A and -2A are the outputs of the 4V RMS transformer winding. As +2A goes positive D31 conducts and attempts to pass current through L1, F1 through its stimulus lead and return through the lead at the opposite diagonal of the board, during this half cycle the other stimulus circuit is inactive.

As current flows through inductor L1 Hall sensor Q12 detects its presence and the monostable U61A is repeatedly clocked, the output of the monostable is OR'd with its equivalent in the other stimulus circuit and if either inductor L1 or L2 is NOT conducting NO_PLANE_DS will be low.

NO_PLANE_DS is monitored by the microprocessor in PLANE SHORTS mode. When the user presses PLANE to activate the mode the 970 will turn on relay K14 on; if no current is detected in L1 or L2, K14 will be turned off.

In order to protect semiconductor devices, D30 and D34 are Schottky diodes which conduct if the stimulus voltage attempts to rise above approximately 0.4 volts. This will occur if the stimulus is not connected correctly. As D30 or D34 conduct, current no longer flows through L1 or L2, the microprocessor registers NO_PLANE_DS and turns off K14.

This feature will turn off the stimulus at any time it is disconnected while "Active".

Drive Source

The Drive Source provides an 80kHz ac low impedance output for non-contact current tracing.

U13 and U19 form a gated oscillator, enabled only in TRACE mode. Q3 and Q4 provide a low impedance output, U13A monitors the output current turning on the front panel TRACE DRIVE indicator when a current of > approximately 5mA is flowing.

U13D and Q4 comprise a protection circuit which cuts off drive to Q3 should the leads be connected to a negative voltage. D39 provides protection from positive voltages.

Tone Generator

U20D and Q7 form a VCO whose frequency is proportional to the voltage at TONE_GEN or its inverse if INVERT is selected. The output of the VCO is made symmetrical by U21B, which is also gated by the microprocessor to allow the tone to be turned off in the 20V range and during current auto-ranging. U64 is a voltage controlled amplifier providing volume adjustment from the front panel, U22 provides the audio power output.

The following controls are applied to the tone generator:

TRACE — U20A and B detect a band of $\pm 40\mu\text{V}$ and turn off the tone in this region. A voltage more negative than $40\mu\text{V}$ causes oscillator U17D to generate a unique pulsing tone.

All resistance ranges — Invert is off and at low readings U20A goes high allowing U17D to oscillate and cause a pulsing tone at low readings.

Power Supply

U32 and U33 provide analog ± 5 Volt supplies. LK7 or 8 allow the Phase of the line signal to be selected in case of transformer phase change. (This will affect left and right arrows in PLANE SHORTS.)

U31 provides a separately regulated 5V supply for the digital systems and relay drive.

U30 Provides a floating +5Volts for the drive source.

+2A and -2A is a floating 4V RMS supply for the Vectored Stimulus.

Microprocessor

The system is based on a Z80, U35, which is reset and shut down by controller U38.

4MHz Resonator X1 is divided by 2 to produce a 2MHz system clock.

Firmware is held in ROM U36, and U34 provides 2K of utility RAM. The remainder of the bus related circuits provide I/O for controlling or monitoring the instrument. U43 and U37 provide appropriate address decoding.

Front Panel

(Schematics 1 and 2)

The digital part of the front panel is an extension of the processor system providing a keyboard row and column decoder U49 and U52 and other ports for LED drive.

U57 and associated components form the drive for the Plane Direction arrows and come under the control of the Vector discriminator circuit.

D76 is a backlight array for the LCD whilst U53 provides display A2D conversion and LCD Drive, U56 provides logic level conversion for decimal points and U54 is the LCD.

DISMANTLING INSTRUCTIONS

WARNING Service of this instrument should only be performed by skilled electronics service personnel.

There are hazardous voltages inside the instrument when connected to its power supply. REMOVE THE POWER CORD before touching any part of the line input circuit. Note that high voltages may continue to be present for 2 minutes after power is removed until internal capacitors discharge.

Undo the two screws in the rear of the cover, then lift the cover rear edge first and remove.

The main printed circuit board must be removed before the front moulding or feet can be removed.

LINE VOLTAGE AND FUSE CHANGING

WARNING Service of this instrument should only be performed by skilled electronics service personnel.

There are hazardous voltages inside the instrument when connected to its power supply. REMOVE THE POWER CORD before touching any part of the line input circuit. Note that high voltages may continue to be present for 2 minutes after power is removed until internal capacitors discharge.

Note: When replacing fuses always use the type and rating stated in SPECIFICATIONS.

Changing the line voltage setting

When changing the line voltage it will be necessary to dismantle the instrument as described in the DISMANTLING INSTRUCTIONS — changes may be made as follows:

1. Remove the two screws in the rear of the cover and lift off (lift the rear first).
2. Remove the gold plated links (extract the links with small pliers) and replace them in the locations corresponding to the local line voltage.
3. Locate the 2 supply fuses and replace with the value and rating stated in SPECIFICATIONS.
4. Replace the cover.
5. Erase the marking on the label on the rear of the instrument and mark in the new voltage setting.
6. *NOTE: 100V instruments cannot be changed.*

FAULT DIAGNOSIS

WARNING Service of this instrument should only be performed by skilled electronics service personnel.

Hazardous voltages are exposed on the PCB when the cover is removed. These procedures should only be performed by a technically qualified person aware of the hazards and taking all reasonable care.

Troubleshooting hints

1. If the instrument is completely dead check the fuses and line voltage selection. Inspect carefully for signs of damage, loose wires, etc. *Rectify any faults before applying power.*
2. If there is no "beep" or flashing LED sequence at switch on, the microprocessor is not operating. Check the internal power supplies, ROM, crystal and microprocessor reset circuits.
3. If there is an OHMS fault check the input amplifier first, then check the operation of the current generator.
4. If ACTIVE cannot be engaged in PLANE SHORTS check the 5A fuses in the stimulus circuit. The connections to the plane drive sockets should also be checked, and the sense coils which should be close around the sensor IC.
5. In TRACE mode, for optimum sensitivity tune the circuit to the Trace Probe (Probes may differ).

MAINTENANCE AND CLEANING

Cleaning

Clean the unit with a cloth lightly moistened with water with a small amount of mild detergent.

Alternatively, a cloth lightly moistened with alcohol (ethanol or methylated spirit) or isopropyl alcohol (IPA) may be used.

Do not spray cleaners directly onto the instrument.

Technical support

For technical support contact your local Polar Instruments distributor or Polar Instruments Ltd. at the address at the front of this manual.

Instrument repair

If it becomes necessary to repair the instrument, in the first instance contact the Polar Instruments distributor in your country. In case of difficulty contact Polar Instruments Ltd. at the address at the front of this manual. *Do not send the instrument until shipping instructions have been received from the repairer.*

REPLACEMENT PARTS

To ensure correct parts are supplied, orders for replacements should include the following details:

Instrument type

Instrument serial number

Firmware version (if applicable)

Circuit reference (if applicable) and description

Note: Parts marked with an asterisk (*) have been subject to modification in later instruments.

Safety critical parts (listed in bold type) must be replaced with parts obtained from Polar Instruments Ltd or your Polar Instruments distributor to ensure continued safe operation.

FRONT PANEL KIT

Part N°	Qty	Description	CircuitReference
CEA103	3	10µF Electrolytic	C57, C66, C68
CVD101	1	0.1µF Polyester	C61
CVD102	1	0.01µF Polyester	C62
CVD105	2	0.22µF Polyester	C58, C59
CVD116	1	100pF Ceramic	C60
CVD136	4	0.1µF MiniCeramic	C67, C69
CVD154 *	2	2n2 Polyester	C700, C701
ICA129	1	7106	U53
ICA130	1	4070	U55
ICA192	3	74HC374	U50, U51, U52
ICA208	1	74HCT373	U49
ICA221	1	74HC139	U57
ICA243	1	4051	U56
LDD116	1	LCD	U54
LDD117	1	Backlight	D76
LED115	12	LED Red	D46-D48, D50-D52, D54, D65-D69
LED116	10	LED Yellow	D53, D55, D56, D57, D58, D59, D60, D61, D62, D63
LED117	1	LED Green	D64
MKB154	12	Button Cap	
MPP200	16	3.8mm Spacer	
MPP201	7	4.3mm Spacer	
MQX138	1	28 Pin IC Socket	
MQX238	2	LCD Connector	
QNN304	1	2N3904 Transistor	Q10
RCC127	1	8 x 22K Rpak	RP5
RCF100K	1	100K 1/4W 5%	R195
RCF1M0	4	1M0 1/4W 5%	R194, R198, R199, R200
RCF200R	1	200R 1/4W 5%	R185
RCF22K	1	22K 1/4W 5%	R197
RCF270R	20	270R 1/4W 5%	R174, R175, R176, R177, R178, R179, R180, R181, R182, R183, R184, R216, R217, R218, R219, R220, R221, R222, R223, R224
RCF330R *	4	330R 1/4W 5%	R700, R701, R702, R703
RCF390R	7	390R 1/4W 5%	R186, R187, R188, R189, R190, R214, R215
RCF39R	7	39R 1/4W 5%	R227, R228, R229, R230, R231, R232, R233
RVB320	1	1K Preset	R196
RVP114	1	100K Panel Pot	R192
RVP115	1	100K Panel Pot (Dual)	R191
SWB141	12	Push-Button	S2, S3, S4, S5, S6, S7, S8, S9, S10, S12, S13, S14

WMA196	1	Cable Assembly	JP4
WMA198	1	Headphone Cable	
WMA199	1	I/P Board Cable	
WMA206	1	Drive Source Cable	

MAIN BOARD KIT

Part N°	Qty	Description	CircuitReference
CEA103	12	10 μ F Electrolytic	C4, C5, C29, C41, C49, C50, C52, C53, C71, C75*, C78*, C82
CEA105	1	220 μ F Electrolytic	C32
CEA117	4	2,200 μ F Electrolytic	C40, C43, C45, C46
CEA122	2	1 μ F 63V Electrolytic	C75*, C79*
CVD101	24	0.1 μ F Polyester	C1, C6, C7, C8, C9, C14, C15, C17, C18, C26, C31, C33, C56, C64, C65, C70, C72, C74, C75*, C76, C78, C79*, C85, C90*
CVD102	13	0.01 μ F Polyester	C3, C20, C24, C27, C28, C30, C35, C39, C73, C77, C89, C705, C706
CVD105	3	0.22 μ F Polyester	C36, C80, C81
CVD106	2	82pF Ceramic	C19, C38
CVD109	30	0.1 μ F Radial Ceramic	C44, C48, C83, C86, C702, C707, C714
CVD113	3	1 μ F Polyester	C23, C34, C88
CVD115	3	33pF Ceramic	C21, C54, C55
CVD116	1	100pF Ceramic	C708
CVD130	1	0.022 μ F Polyester	C2
CVD143	2	0.1 μ F Polyester	C51, C91
CVD144	5	0.47 μ F Polyester	C11, C12, C13, C16, C37
CVD146	2	1nF Polyester	C92, C93*
CVD147	2	4n7 Polyester	C703, C704
CVD148	2	1nF Polyester	C90*, C93*
DBA102	2	Rectifier Bridge 1.2A	D43, D44
DSP101	40	Diode Signal 150mA	D2, D3, D4, D5, D6, D7, D8, D9, D10, D11, D12, D14, D16, D18, D19, D21, D25, D37, D38, D40, D41, D42, D72, D79, D80, D81, D82, D84, D85, D86, D87, D88, D89, D90, D91, D92, D93, D94, D96, D97
DSP102	2	Diode Power 1A 1kV	D13, D39
DSP105	2	Diode Schottky 7.5A	D30, D34
DSP107	6	Diode 1N5401	D31, D32, D35, D73, D77, D78
DZA303	2	Zener Diode 3.3V	D1, D83

DZA320	1	Zener Diode 5V1	D29
EPM112	1	Buzzer	SP2
FCA124 *	4	5A Fuse Wire ended	F1, F2, F3, F4
FCA130	1	0.5A T Wire ended	F7
FSW122	1	Firmware ROM	U36
ICA106	4	LM339N	U13, U17, U20, U61
ICA116	1	MC14016BCP	U23
ICA122	1	MC14013BCP	U21
ICA125	2	ICL7650CPD	U1, U12
ICA126	1	CA3140E	U16
ICA128	3	MC7805CT	U30, U31, U32
ICA158	1	MC74HC00N	U15, U18*
ICA161	1	MC7905CT	U33
ICA162	1	LF353N	U60
ICA164	1	74HC132	U18*
ICA165	2	LM311N	U10, U14
ICA166	1	CD74HC74E	U44
ICA173	1	MC74HC04N	U3
ICA186	2	TL084CN (or LF347N)	U2, U9
ICA187	1	LM386N-1	U22
ICA188	1	Z80	U35
ICA189	1	TL 7705	U38
ICA190	2	74HC138	U37, U43
ICA191	1	74HC08	U41
ICA192	6	74HC374	U28, U39, U40, U46, U47, U61
ICA195	1	74HC32	U29
ICA198	1	74HC245	U45
ICA208	1	74HCT373	U48
ICA212	1	L272	U62
ICA234	1	Quad Opto-Isolator	U19
ICA239	1	6116 RAM	U34
ICA241	3	4052B	U8, U25, U59
ICA245	1	DAC0800	U27
ICA263	2	74HC4053	U4, U24
ICA265	2	Ratiometric Hall Sensor	Q11, Q12
ICA266	1	CA3080E	U64
ICA267	1	ICL7109	U26
ICA268	1	REF25Z	U65
ICA269	3	TLC279	U6, U7, U58
ICA299	1	TL082	U5
ICA305	1	74C04	U42
IND107	1	10uH	L700
IND105	2	Inductor 10TURN	L1, L2
LDD115	1	4MHz Ceramic Resonator	X1
MAA123	2	Fuseholder	F5, F6
MQX138	1	28 PIN IC SKT	
MQX139	2	40 PIN IC SKT	

MQX140	1	PIN HEADER	JP3
MQX158	2	2-Way Header	JP9,JP13
MQX259P3	2	3 X 1 Pin Header	JP10, JP12
MQX259P10	1	10 X 1 Pin Header	JP11
MQX237	4	6.35mm Spade Connector	
MQX284	1	Latched Header	Vertical 40 Pin
MQX299 *	2	Link	Line Select
MQX300 *	5	1mm Socket	
QNN304	2	2N3904	Q3, Q8
QPP102	3	2N3906	Q4, Q7, Q9
QPP103	1	MJE350	Q2
RCC103	1	120R 5%	R7
RCC108	1	68R 2W 5%	R102
RCC120	1	3K3 x 8 SILPAK	RP1
RCC127	5	8 x 22K SILPAK	RP2, RP3, RP4, RP6, RP7
RCC143	2	2R2 11W	R125, R126
RCC161	2	V33ZA5	R710, R711
RCF100K	20	100K 5%	R6, R7,R17, R33, R72,.R78, R83, R93, R128, R130, R138, R152, R154, R158, R164,R247, R259, R264, R289, R297
RCF100R	2	100R 5%	R79, R298
RCF10K	25	10K 5%	R12, R29, R31*, R63, R64, R74, R75, R86, R88, R89, R112, R124, R127, R147, R155, R171, R207, R208, R209, R256, R260, R265, R279, R281, R282, R717
RCF10M	1	10M 5%	R251
RCF10R	1	10R 5%	R174, R714
RCF150K	2	150K 5%	R2, R244
RCF15K	1	15K 5%	R28*
RCF1K0	25	1K0 5%	R15, R16, R18, R21, R23, R92, R100, R109, R129, R201, R206, R213, R234, R235*, R236, R237, R253, R258, R263, R266, R269, R272, R276, R286, R290
RCF1K2	2	1K2 5%	R140, R142
RCF1K5	1	1K5 5%	R288
RCF1K8	2	1K8 5%	R144, R274
RCF1M0	3	1M0 5%	R145, R161, R172, R715
RCF1R0	3	1R0 5%	R4, R273, R277
RCF200R	4	200R 5%	R8, R239, R245, R287
RCF20K	6	20K 5%	R22, R28*, R162, R240, R241 R246

RCF22K	6	22K	5%	R133, R134, R136, R137, R157, R165
RCF22R	1	22R	5%	R268
RCF270R	1	270R	5%	R148
RCF2K2	2	2K2	5%	R242, R271
RCF2M2	1	2M2	5%	R151
RCF2R2	2	2R2	5%	R5, R103
RCF330R	1	330R	5%	R235*
RCF360K	2	360K	5%	R243, R280
RCF390R	3	390R	5%	R108, R122, R173
RCF3K9	3	3K9	5%	R104, R105, R275
RCF470K	7	470K	5%	R26*, R80, R153, R156, R249 R262, R270
RCF47K	11	47K	5%	R32, R90, R91, R131, R132, R139, R141, R149, R150, R261, R267
RCF4K7	10	4K7	5%	R19, R82, R110, R111, R250, R254, R255, R278, R294, R296
RCF4M7	2	4M7	5%	R106, R107
RCF560K	1	560K	5%	R1
RCF56K	1	56K	5%	R27*
RCF56R	3	56R	5%	R20, R24, R257
RCF5K6	4	5K6	5%	R101, R135, R143, R248
RCF68K	1	68K	5%	R27*
RCF8K2	2	8K2	5%	R31*, R712
RCF820K	1	820K	5%	R26*
RCF91K	2	91K	5%	R123, R291
RCT100K	5	100K	1/4W 1%	R45, R58, R59, R60, R68, R91
RCT10K	8	10K	1/4W 1%	R51, R52, R53, R55, R57, R292, R293, R295
RCT10R	1	10R	1/4W %	R38
RCT113K	1	113K	1/4W 1%	R95
RCT11R0	2	11R0	1/4W 1%	R37, R42
RCT180K	1	180K	1/4W 1%	R87
RCT1K	1	1K	1/4W 1%	R3
RCT1M0	3	1M0	1/4W 1%	R46, R54, R56
RCT1R0	3	1R0	1/4W 1%	R36, R43, R284
RCT200R	1	200R	1/4W 1%	R203
RCT20K	2	20K	1/4W 1%	R11, R96
RCT220K	1	220K	1/4W 1%	R97
RCT24K	1	24K	1/4W 1%	R14
RCT2K0	3	2K0	1/4W 1%	R10, R159, 5160
RCT430K	1	430K	1/4W 1%	R204
RCT470K	1	470K	1/4W 1%	R13
RCT560R	1	560R	1/4W 1%	R41
RCT5K6	1	5K6	1/4W 1%	R40
RCT56R	1	56R	1/4W 1%	R39

RCT75K	1	75K 1/4W 1%	R205
REL111	9	Reed Relay	K2, K3, K6, K7, K8, K9, K10, K11, K12
REL112	2	2-POLE Reed Relay	K1, K4,
REL113	1	SPNO 5A Relay	K14
RVB315	1	100K Preset	R94
RVB316	2	10K Preset	R30*, R713, R716
RVB319	1	10K Preset	R30*
RVB320	1	1K Preset	R163
RVB323	1	100K Preset	R85
SWB133	1	Power Switch	S1
SWB143	1	Line Selector Switch	S15*
TXM125	1	Power Transformer	T2*
TXM146	1	Power Transformer	T2*
WMA108	2	0.5"Link	LK8, R252

MECHANICAL KIT

Part N°	Qty	Description	CircuitReference
CVD155 *	5	470pF Polypropylene	C709, C710, C711, C712, C713
EPM111	1	Loudspeaker	
FCA112	2	Fuse 250mA T	F5*, F6* 115V
FCA119	2	Fuse 125mA T	F5*, F6* 230V
FCA121	2	Fuse 160mA T	F5*, F6* 230V
FCA122	2	Fuse 315mA T	F5*, F6* 115V
IND107 *	1	10uH	L701
IND109	1	Ferrite Clamp	
MCA138	1	Enclosure Top	
MCA139	1	Enclosure Bottom	
MCA143	1	Front Moulding	
MKB127	2	Knob – Cap grey with line	
MKB128	2	Knob – Grey push on	
MKB153	1	Button (Round Black)	
MMP107	5	Nylon Cable Tie 75mm O/A	
MNS107	17	K30 x 6 self tap	
MNS117	2	M3 x 10 Pan Hd	
MNS163	2	M3 x 12 Csk	
MNS164	4	K30 x 10 self tap	
MNS175	2	M3 Flange nut	
MNS176	2	K30 x 8 self tap	
MPP142	2	PCB support	
MPP155	1	Cable Clip	
MPP191	2	Tilt Assembly Leg	
MPP193	4	Bumper Foot	
MPP198	2	Tilt Assembly Base	
MPP210	1	IEC Inlet Boot	
MPP230	3	Cable tie	

MPP231	2	Insert Cover	
MQX154	1	Din Socket 5 x 45'	
MQX155	1	Din Socket 5 x 60'	
MQX158	1	2-Way Header	
MQX179	1	4mm Red Socket	
MQX210	1	4mm Blue Socket	
MQX222	1	3.5mm Stereo PCB Jack	
MQX223	1	5 Pin Din "Domino", Polarised	
MQX224	1	4mm Yellow Socket	
MQX225	1	4mm Green Socket	
MQX254 *	1	IEC Inlet Connector	
MQX314 *	1	IEC Filtered Inlet	
MWP233	1	Front Panel Label	
MWP234	1	LCD Window Label	
MWP235*	1	Rear panel Label	
MWPD1057*	1	Rear Label	
MWPD1079	1	Flexishield	
RCC129	2	82ZA2 Varistor	R705, R710
RCC133	4	22ZA1 Varistor	R706, R707, R708, R709
WMA104	0.25m	Green/Yellow wire	
WMA108	1	0.5" Link	
WMA197	2	Speaker Lead	
WMA202*	4	Plane Cable Blue	
WMA305*	1	Plane Drive Cable	

SCHEMATIC DIAGRAMS

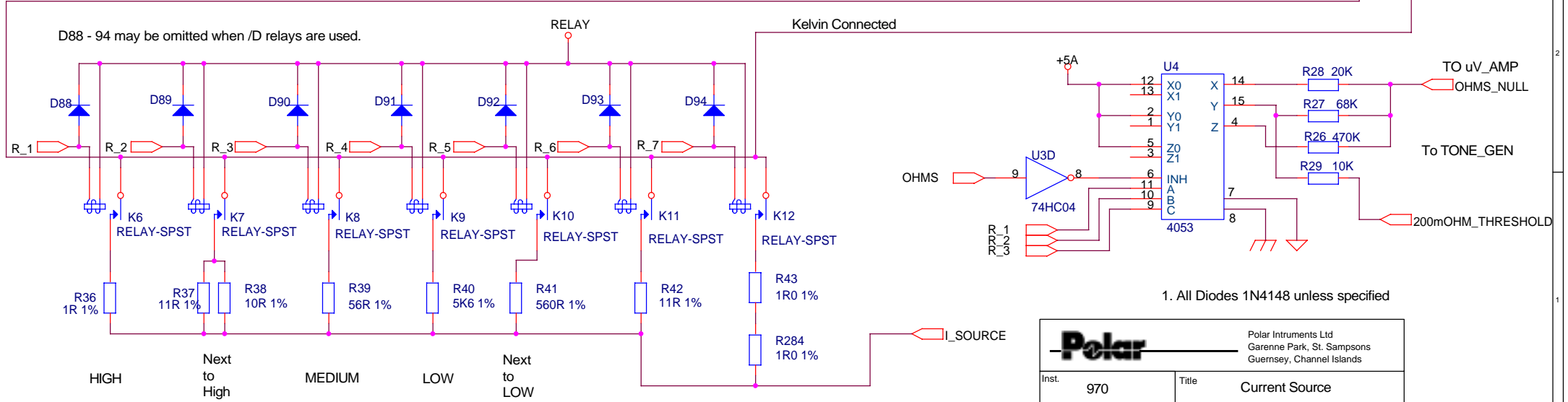
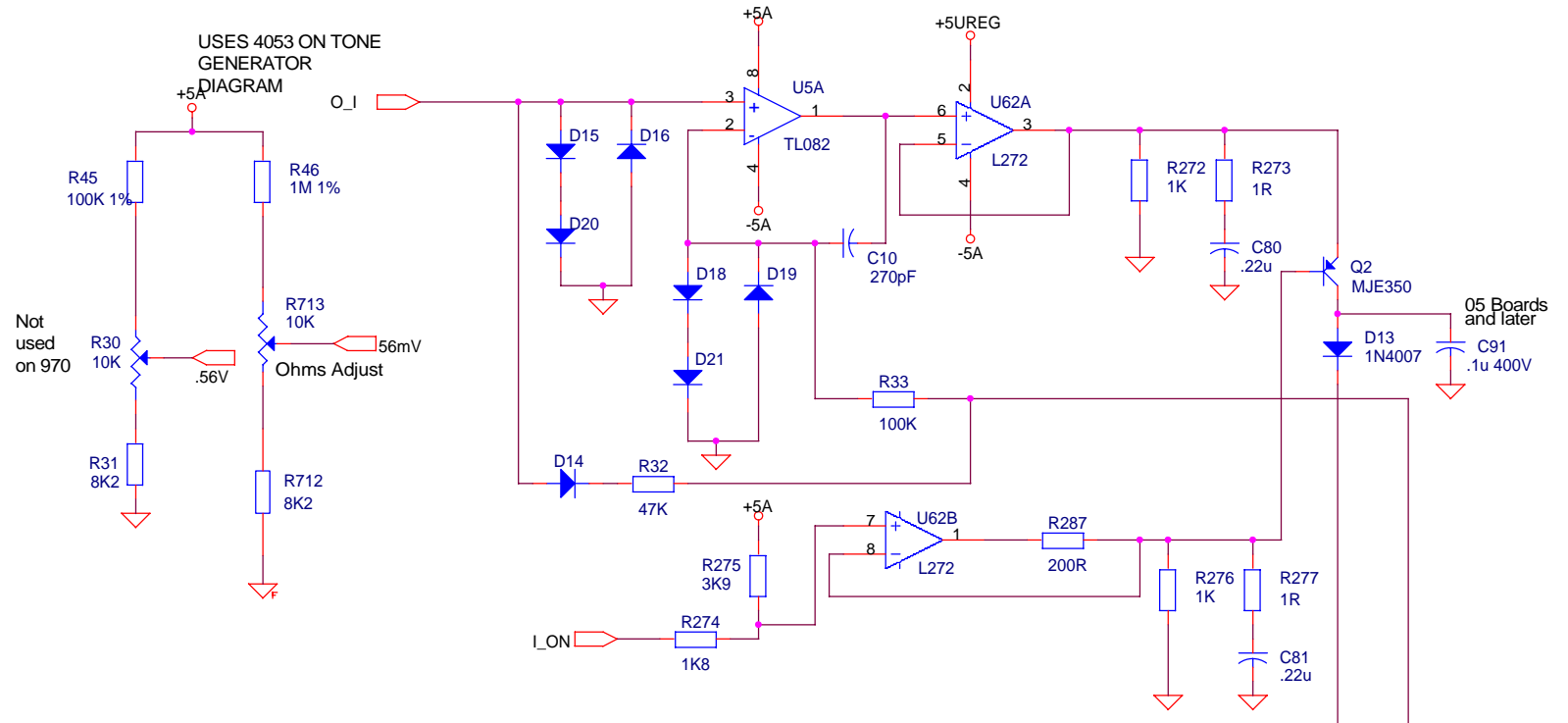

		Polar Instruments Ltd Garenne Park, St. Sampsons Guernsey, Channel Islands	
Inst.	970	Title	Current Source

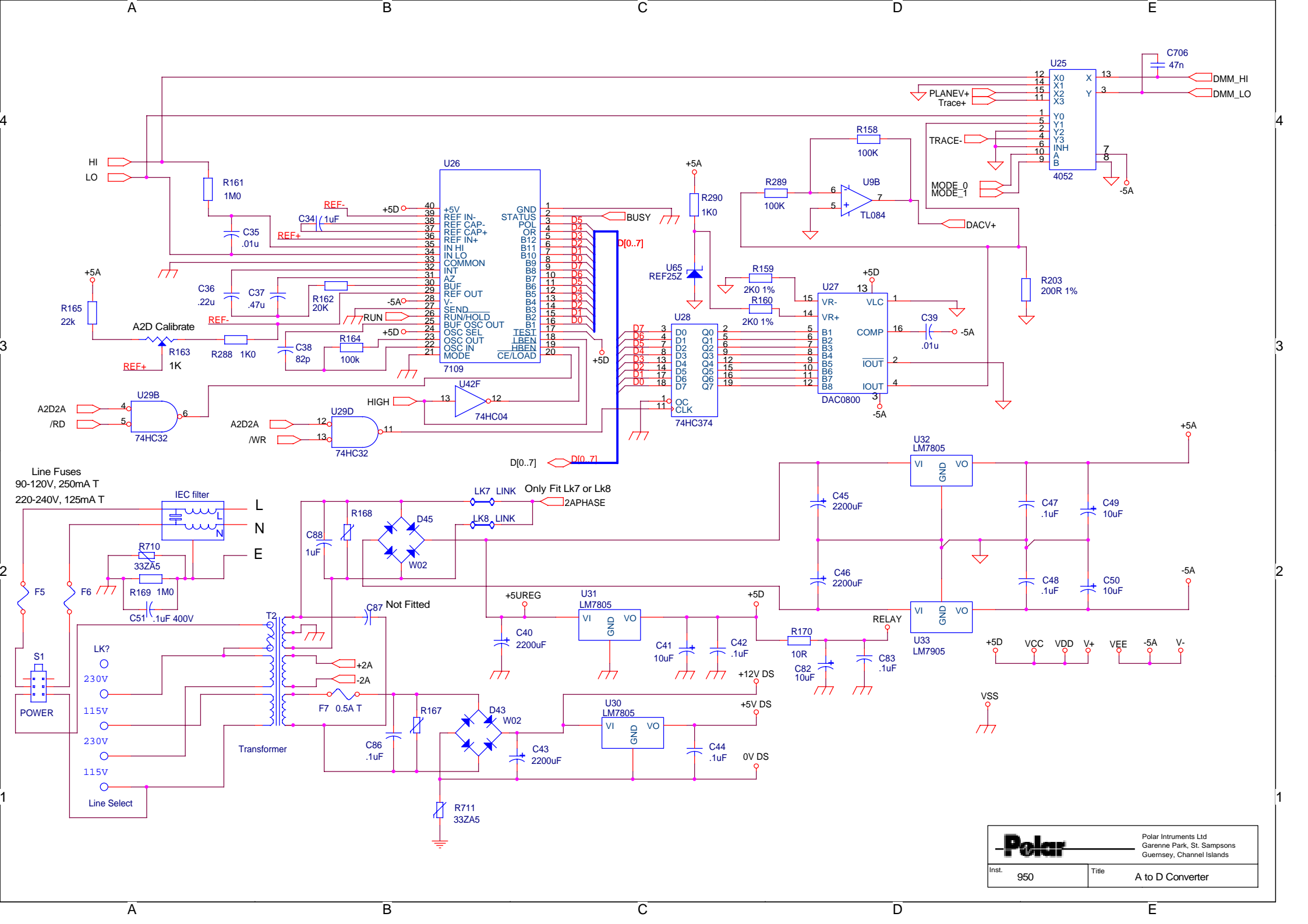

Line Fuses
 90-120V, 250mA T
 220-240V, 125mA T

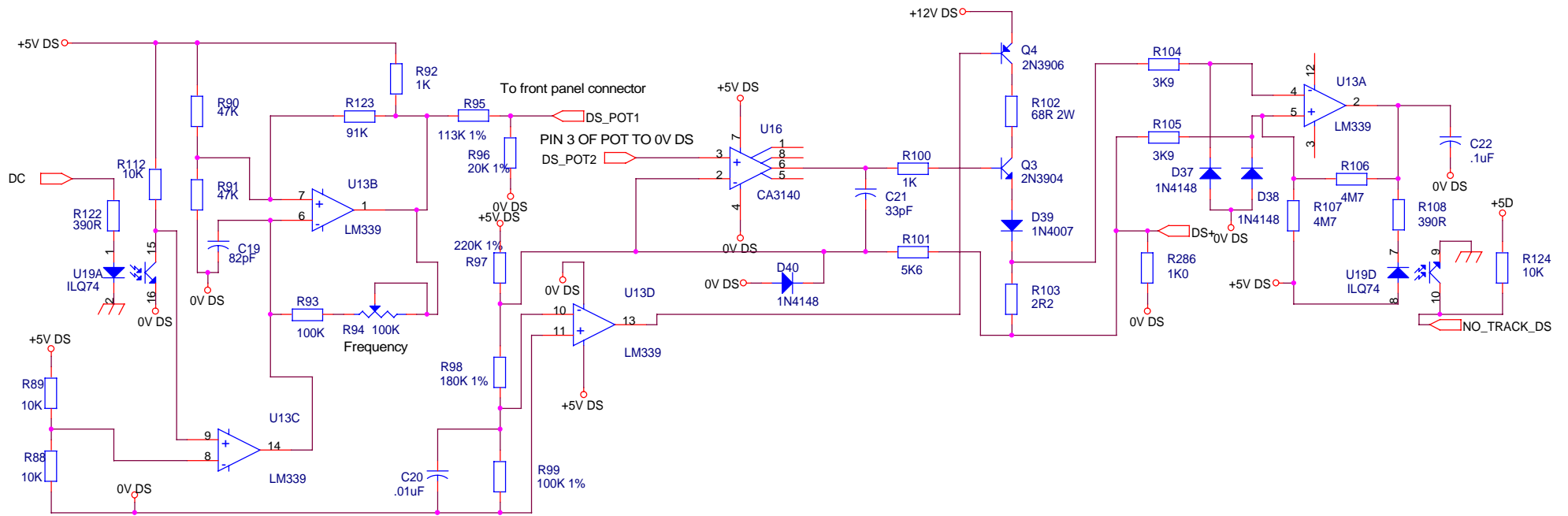

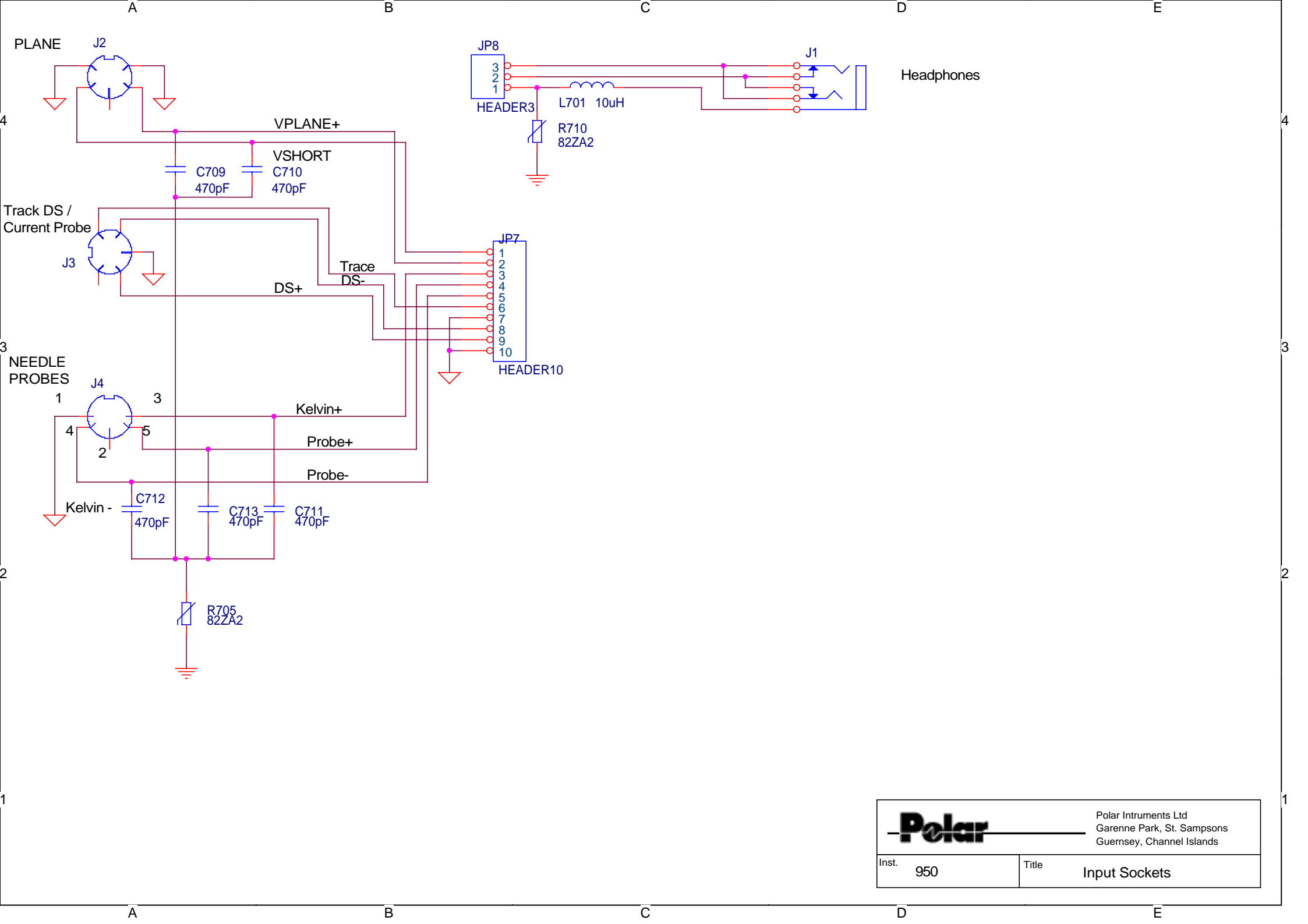

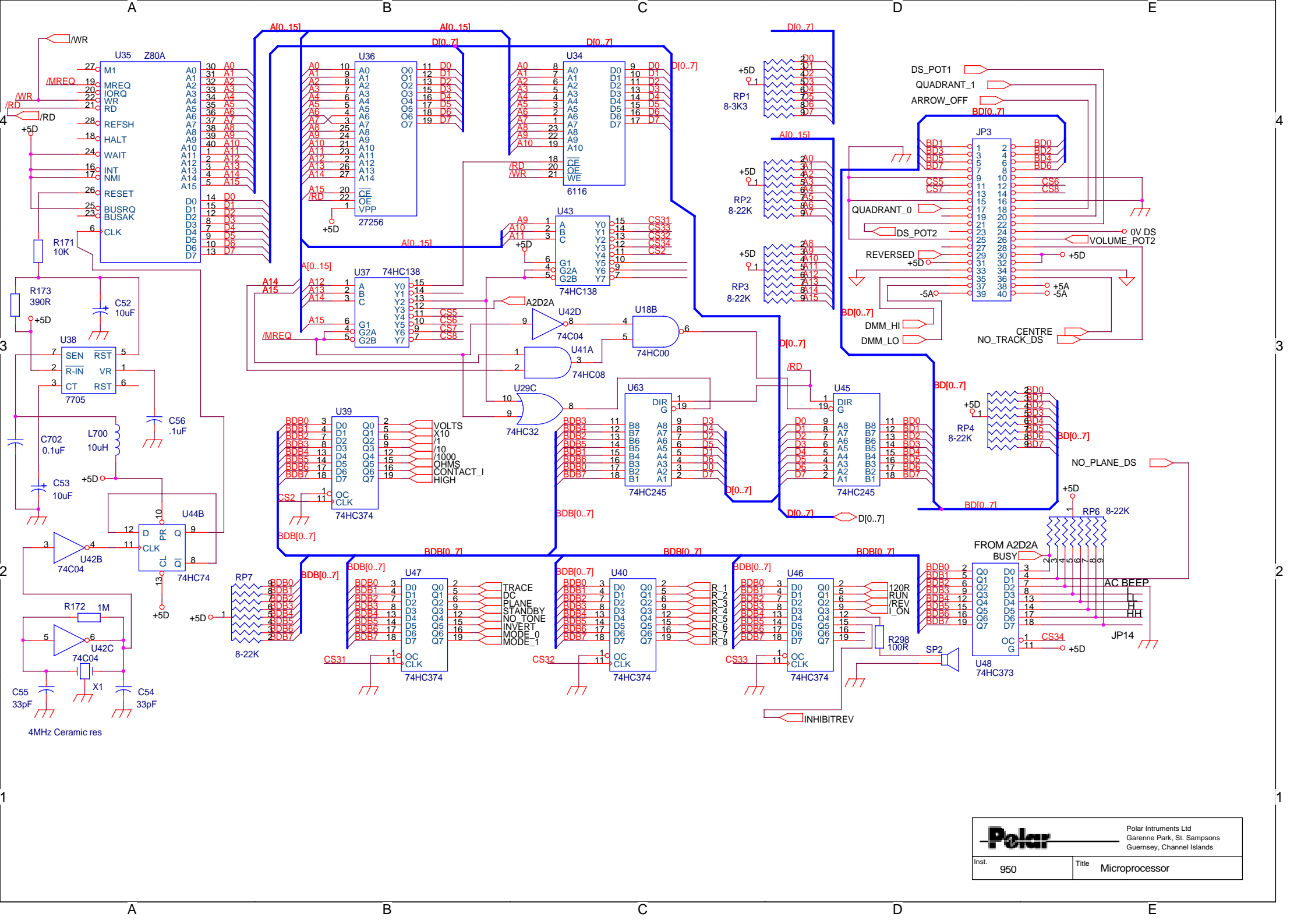

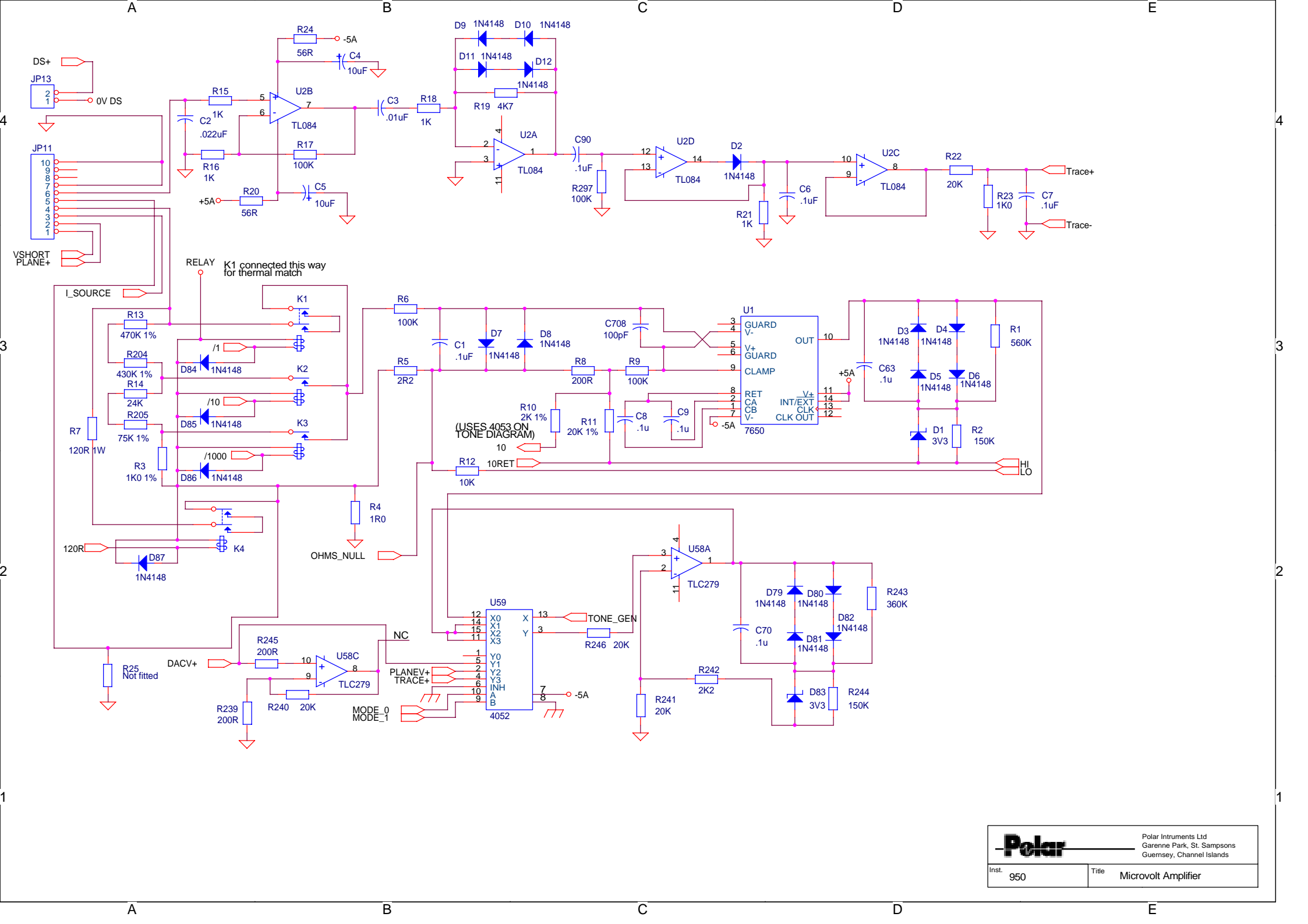

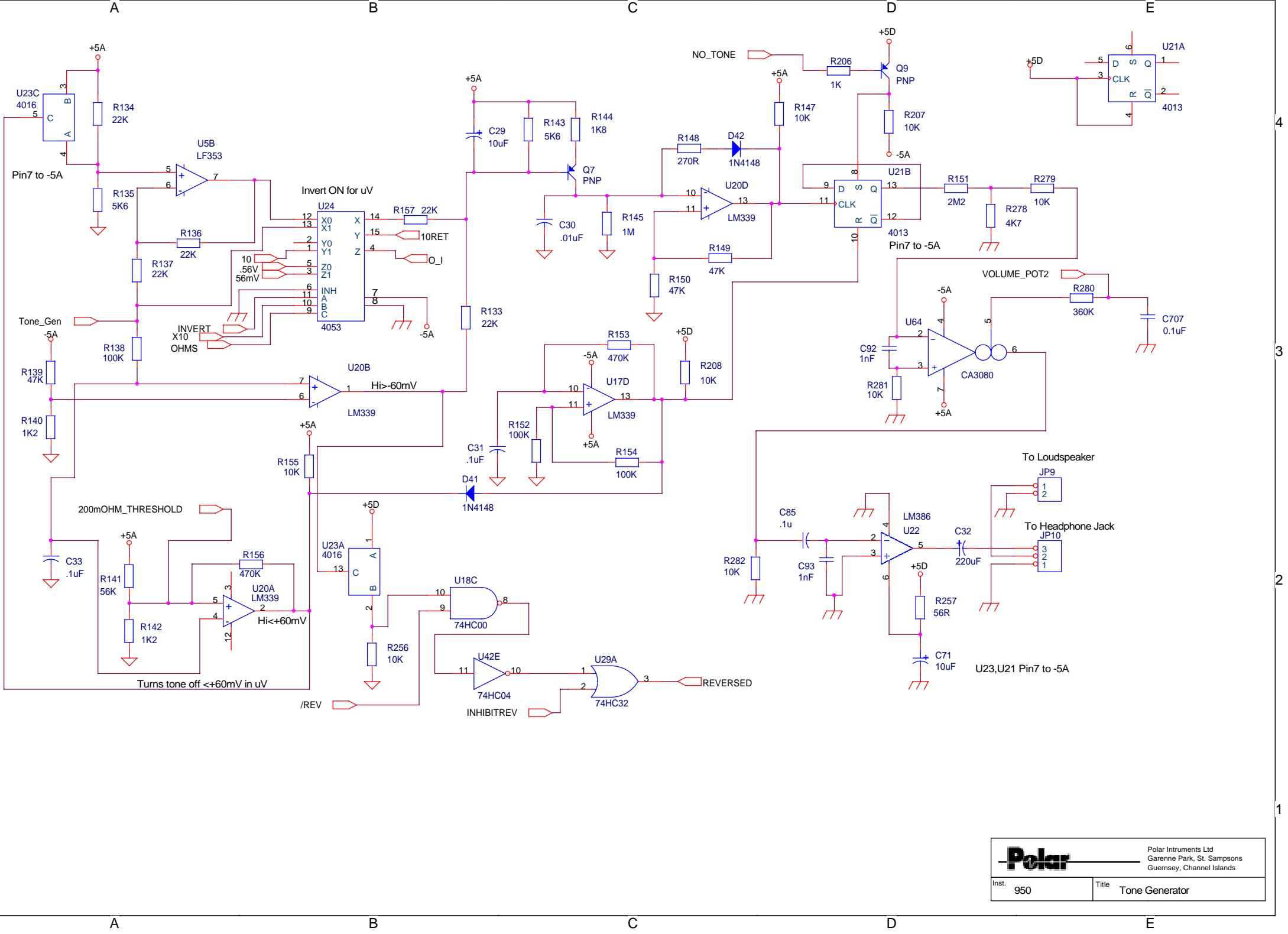

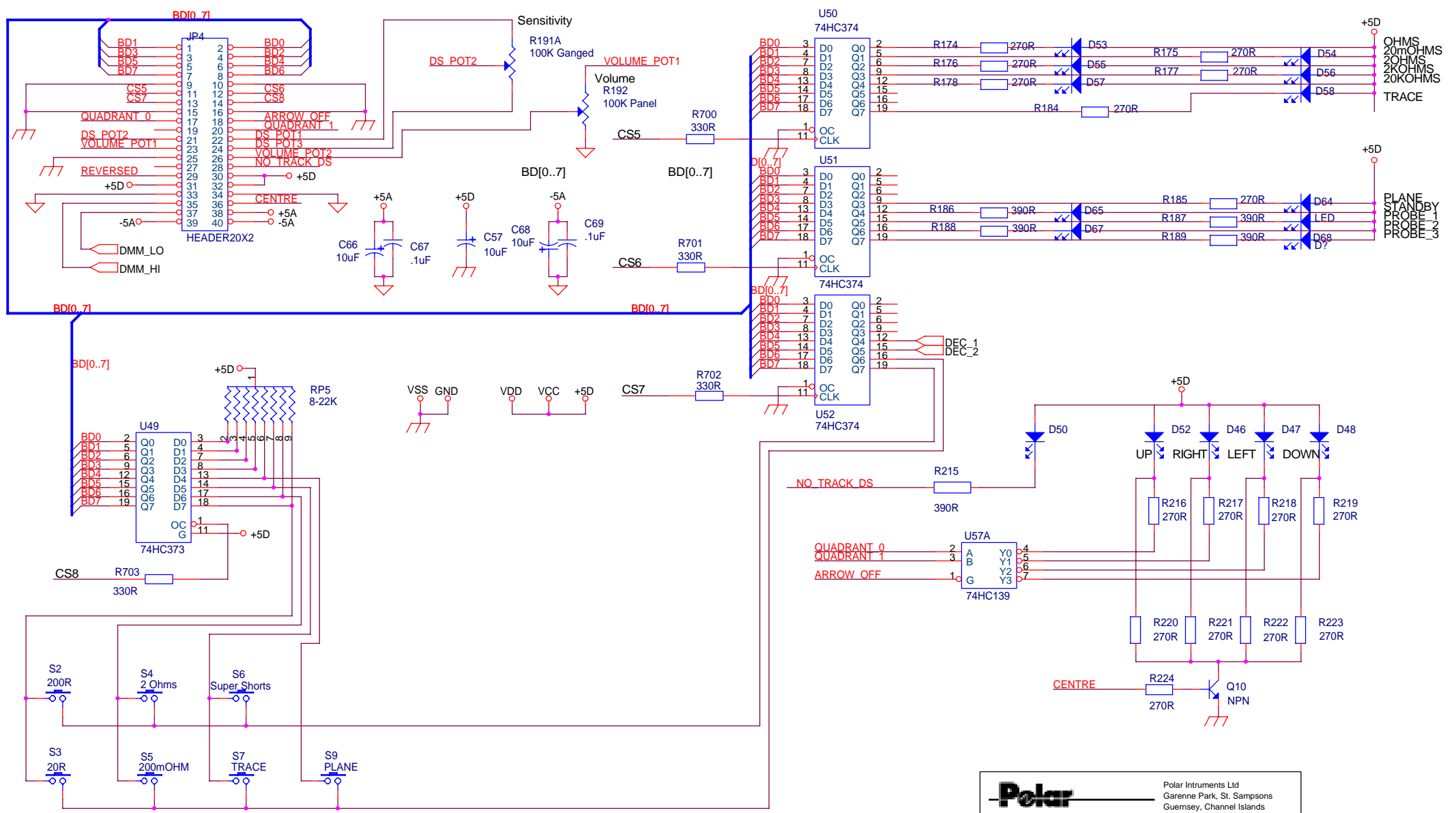

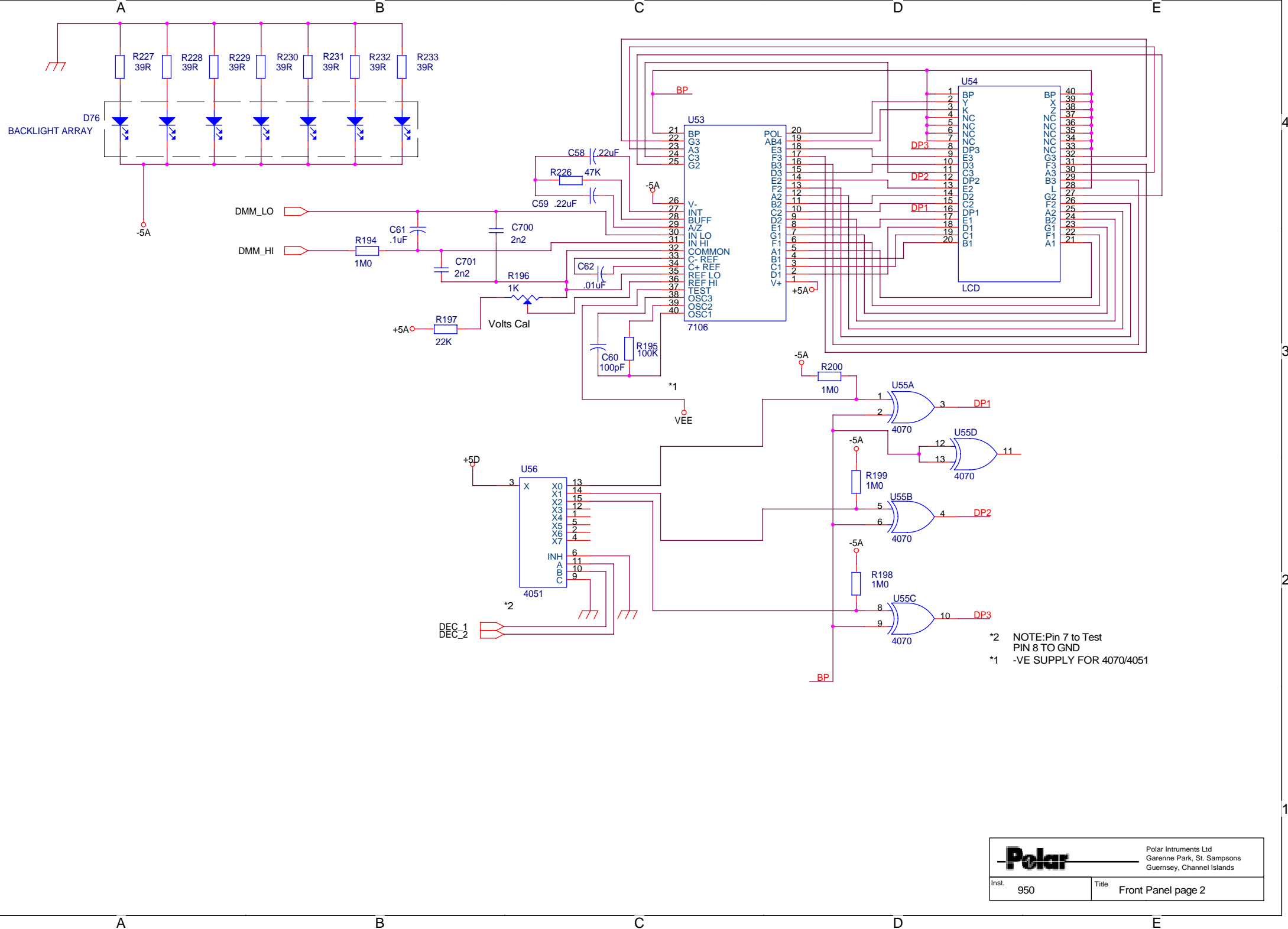

*2 NOTE: Pin 7 to Test
PIN 8 TO GND
*1 -VE SUPPLY FOR 4070/4051