

*In this photo you can see Model SA-5800*

# *Service Manual*

STEREO AMPLIFIER

**SA-5800**  
**SA-508**

 **PIONEER®**

Both Model SA-5800 and Model SA-508 have the same basic performance. The major difference is in appearance, Model SA-5800 being fitted with wooden side cover and top cover, while Model SA-508 employs metal cover. The following table is displayed on the SA-5800 and SA-508.

#### MODEL SA-5800

Type	Voltage	Remarks
KU	120V only	U.S.A. model
KC	120V only	Canada model

#### MODEL SA-508

Type	Voltage	Remarks
KU	120V only	U.S.A. model
S	110V, 120V, 220V, and 240V (Switchable)	General export model
HE	220V and 240V	Europe model
HB	220V and 240V	United Kingdom model
HP	220V and 240V	Oceania model

- This service manual is applicable to the KU type of the Model SA-5800 and the Model SA-508. When repairing the KC type of the Model SA-5800 and the S type of the Model SA-508, please see the additional service manual (ART-373), and for HE, HB, HP types of the SA-508, please see the additional service manual (ART-374).

## CONTENTS

1. SPECIFICATIONS .....	3	9. SCHEMATIC DIAGRAM, P.C. BOARD PATTERNS AND PARTS LIST	
2. FRONT PANEL FACILITIES .....	4	9.1 Miscellanea .....	14
3. BLOCK DIAGRAM .....	6	9.2 Schematic Diagram .....	15
4. CIRCUIT DESCRIPTIONS .....	6	9.3 P.C. Board Connection Diagram .....	18
5. DISASSEMBLY .....	8	9.4 Parts List of P.C. Board Assemblies .....	21
6. ADJUSTMENTS .....	9	10. PACKING .....	23
7. PARTS LOCATION .....	10	11. SUPPLEMENTS FOR MODEL SA-508/KU .....	23
8. EXPLODED VIEW .....	12		

# 1. SPECIFICATIONS

## Semiconductors

ICs .....	3
Transistors .....	21
Diodes .....	18

## Amplifier Section

Continuous Power Output of 25 watts\* per channel, min., at 8 ohms from 20 Hertz to 20,000 Hertz with no more than 0.03 % total harmonic distortion or 25 watts per channel at 4 ohms from 20 Hertz to 20,000 Hertz with no more than 0.05% total harmonic distortion.

Total Harmonic Distortion (20 Hertz to 20,000 Hertz, 8 ohms, from AUX)	
continuous rated power output . . .	No more than 0.03%
12.5 watts per channel power output	
.....	No more than 0.03%
1 watt per channel power output	
.....	No more than 0.03%
Intermodulation Distortion (50 Hertz: 7,000 Hertz = 4:1, 8 ohms, from AUX)	
continuous rated power output . . .	No more than 0.03%
12.5 watts per channel power output	
.....	No more than 0.03%
1 watt per channel power output	
.....	No more than 0.03%

## Output

Speaker .....	A, B, A+B
	4~16 ohms
Headphones .....	Low impedance
Damping Factor (1,000 Hertz, 8 ohms) .....	30
Input (Sensitivity/Impedance)	
PHONO .....	2.5mV/47kilohms
TUNER .....	150mV/50kilohms
AUX .....	150mV/50kilohms
TAPE PLAY 1 .....	150mV/50kilohms
TAPE PLAY 2 .....	150mV/50kilohms

## Phono Overload Level (T.H.D. 0.1% 1,000Hz)

PHONO .....	140mV
-------------	-------

## Output

TAPE REC 1 .....	150mV
TAPE REC 2 .....	150mV

## Frequency Response

PHONO (RIAA Equalization)	
.....	30Hz to 15,000Hz $\pm$ 0.5dB
TUNER, AUX, TAPE PLAY	
.....	20Hz to 40,000Hz $\pm$ 2dB

## Tone Control

BASS .....	+7.5dB, -7.5dB (100Hz)
TREBLE .....	+8dB, -8dB (10kHz)

Subsonic Filter .....	15Hz (-6dB/oct)
Loudness Contour (Volume control set at -40dB position) .....	+6dB (100Hz)
Hum and Noise (IHF, short-circuited, A network)	
PHONO .....	76dB
TUNER, AUX, TAPE PLAY .....	98dB

## Miscellaneous

Power Requirements .....	120V, 60Hz
Power Consumption .....	75W (UL), 180W (CSA)
Dimensions .....	451(W) x 151(H) x 271(D)mm
	17-3/4(W) x 5-15/16(H) x 10-11/16(D) in
Weight (without package) .....	7.3kg (16lb 2oz)

## Furnished parts

Operating instructions .....	1
------------------------------	---

\* Measured pursuant to Federal Trade Commission's Trade Regulation rule on Power Output. Claims for Amplifiers.

## NOTE:

Specifications and the design subject to possible modification without notice due to improvements.

## 2. FRONT PANEL FACILITIES

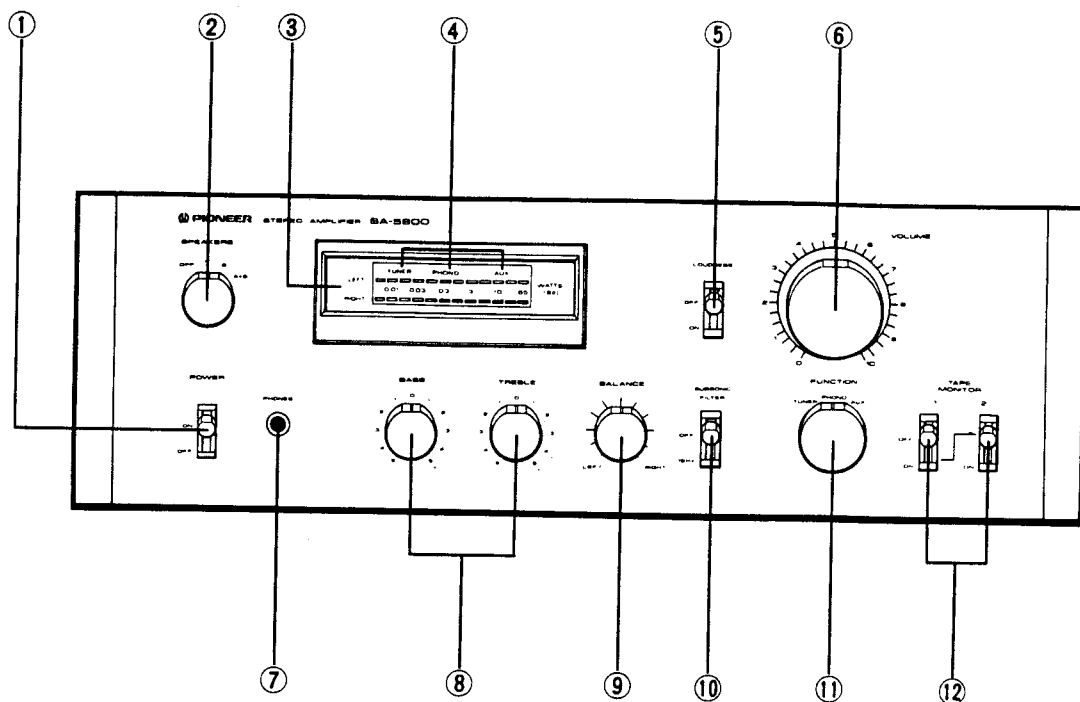

### ① POWER SWITCH

Set this switch to ON to supply power to the amplifier.

### ② SPEAKER SELECTOR

Use this selector to select the speaker systems.

OFF: Sound not obtained from speakers.

A: Sound obtained from speakers connected to the A speaker terminals.

B: Sound obtained from speakers connected to the B speaker terminals.

A+B: Sound obtained from speakers connected to both A and B speaker terminals.

### ③ POWER METER

This meter allows you to read out the rated power level on the fluorescent display tube when speakers with a nominal impedance of 8 ohms are connected to the amplifier's speaker terminals.

### ④ FUNCTION INDICATORS

The TUNER, PHONO, AUX function indicators light up in accordance with the position of the function selector.

*NOTE:*

*The function indicator will not go off even when the tape monitor switch 1 or 2 is set to ON.*

### ⑤ LOUDNESS SWITCH

When listening to a performance with the volume control turned down, set this switch to ON and the bass will be accentuated.

When the volume is low, the human ear finds it harder to hear the bass than when the volume is high. The loudness switch is thus designed to compensate for this deficiency. By setting it to ON, the bass comes through much more strongly and the sound takes on a punch even when the volume control is turned down.

**⑥ VOLUME CONTROL**

Use this control to adjust the output level to the speakers and headphones. Turn it clockwise to increase the output level. No sound will be heard if you set it to "0".

**⑦ HEADPHONE JACK**

Plug the headphones into this jack when you want to listen through your stereo headphones.

**NOTE:**

*Set the speaker selector to OFF when listening only with headphones.*

**⑧ BASS AND TREBLE CONTROLS**

Use these controls to adjust the bass and the treble. If you turn the bass control to the right from its center position, you will be able to emphasize the sound in the low-frequency range. Conversely, turning this control left from the center position, you will attenuate the sound. You can use the treble control to adjust the sound in the high-frequency range.

**⑨ BALANCE CONTROL**

Use this control to balance the volume of the left and right channels. If the sound appears to be louder on the right, it means that the volume of the right channel is higher. Turn the balance control to the left and adjust.

Conversely, if the sound appears to be louder on the left, it means that the volume of the left channel is higher. Therefore, turn the balance control to the right and adjust.

**⑩ SUBSONIC FILTER SWITCH**

When this switch is set to the 15Hz position, the subsonic filter with a cut-off frequency of 15Hz is actuated. The subsonic filter serves to attenuate frequencies lower than 15Hz in a 6dB/oct slope. It is therefore effective in suppressing ultra-low-frequency noise which is generated by record warp and other causes. You cannot actually hear this noise but it is a factor in the generation of intermodulation distortion and it may damage your speaker system. Set this switch to the 15Hz position during record play for the best effect.

**⑪ FUNCTION SELECTOR**

Use this selector to select the program source. When set, the function indicator above the meter panel corresponding to the position of the function selector will light up.

**TUNER:** Set here when listening to broadcasts on a tuner connected to the TUNER jacks. (The TUNER function indicator lights up.)

**PHONO:** Set here when playing records on a turntable connected to the PHONO jacks. (The PHONO function indicator lights up.)

**AUX:** Set here when listening to a program source which is connected to the AUX jacks.

(The AUX function indicator lights up.)

**⑫ TAPE MONITOR SWITCHES (1, 2)**

Use these switches to monitor recording or a tape being played back on a tape deck.

1: Set this switch to ON when you want to monitor a recording or a tape being played back on a tape deck which is connected to the TAPE 1 jacks.

2: Set this switch to ON when you want to monitor a recording or a tape being played back on a tape deck which is connected to the TAPE 2 jacks.

**NOTE:**

*Set these switches to the upper (OFF) position when playing records or listening to broadcasts.*

### 3. BLOCK DIAGRAM

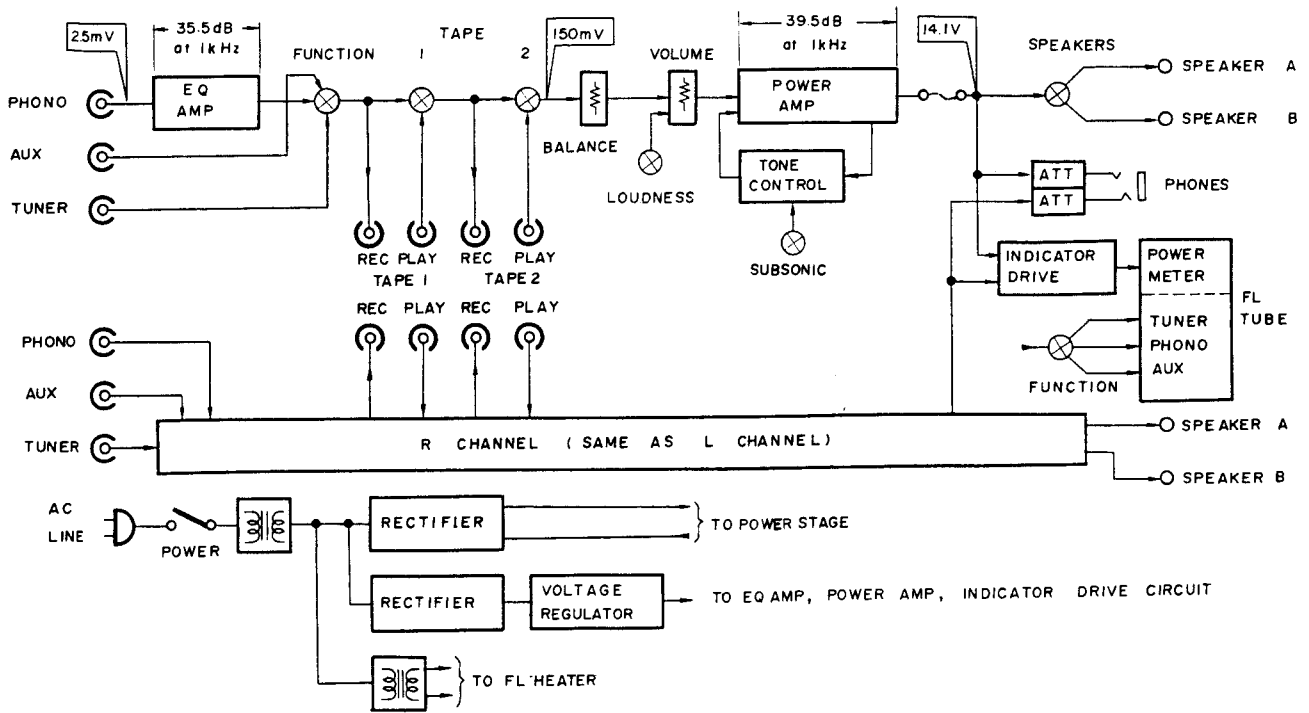

### 4. CIRCUIT DESCRIPTIONS

#### Equalizer Amplifier

The equalizer amplifier is collector-to-emitter feed back type 2-stage direct-coupled amplifier, designed with a gain of 35.5dB (at 1kHz), a overload level of 140mV (at 1kHz, THD 0.1%), and equalizer deviation of  $\pm 0.5$ dB (30Hz-15kHz).

#### Power Amplifier

This all-stage direct-coupled pure complementary SEPP circuit features a current mirror load differential amplifier in the first stage, and incorporates the tone control circuits in the NFB loop.

Although the incorporation of the tone control circuits in the power amplifier stage reduces the number of elements that the signal has to pass through, and thereby further reduces noise, distortion, and cost, the power stage does require a higher gain and a higher degree of stability. In the SA-5800, this high gain and high stability are achieved by a current mirror load differential amplifier in the first stage and by the use of a bootstrap circuit for the load of the pre-driver stage.

The power stage is a Darlington connection pure complementary SEPP circuit, resulting in an output power rating of 25W+25W (8 $\Omega$ , 20Hz-20kHz, THD 0.03%).

The tone controls (BASS, TREBLE) are operated by changing the frequency response of the power amplifier NFB circuit.

#### Power Supply Muting

This circuit is designed to eliminate the unwanted click noise generated when the power switch is turned on and off.

With reference to Fig. 4-1, when the power switch is turned on,  $Q_3$  will remain off because of  $-B_1$ , and then  $Q_1$  emitter will become  $-0.6V$  through the minus voltage supply route ( $D_1$ ,  $D_3$ , and  $R_{16}$ ). The  $Q_1$  base voltage will increase, the rate of increase being determined by the  $R_2$ ,  $R_3$ ,

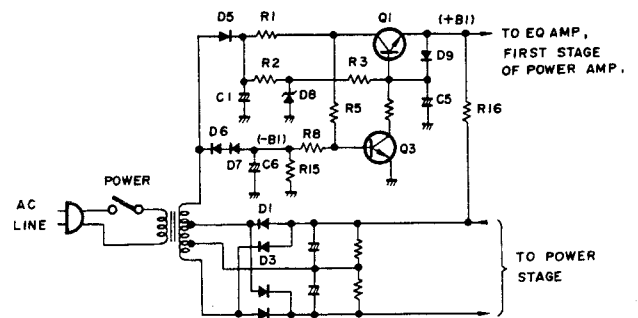

Fig. 4-1 Power supply and muting circuit

and  $C_5$  time constant. Consequently,  $Q_1$  emitter voltage will rise by increase of the base voltage. Therefore, the muting action when the power switch is turned on is achieved by delaying the supply of the  $+B_1$  to the equalizer amplifier and the first stage of the power amplifier.

When the power switch is turned off, the  $-B_1$  is discharged through the route  $R_{15} \rightarrow C_6$ , and since the residual voltage of  $C_1$  is then applied to the base of  $Q_3$  through  $R_1$  and  $R_5$ ,  $Q_3$  is immediately turned on. Therefore, the base voltage of the  $Q_1$  drops to 0V, and the  $+B_1$  supply to the equalizer amplifier and the first stage of the power amplifier are interrupted.

### Indicator Circuit

The SA-5800 output power and function indicators feature fluorescent indicator tube (FL tube). In this tube, thermionic emissions from the cathode are accelerated into the fluorescent substance of the segmental anodes, resulting in the emission of light. This tube is used to indicate numerals, letters, and other symbols.

An outline of the FL tube drive circuit is shown in Fig. 4-2. The output circuit signal is applied to pin no. 6 (4) of the IC (TA7318P-A). The IC contains a detector circuit, compressor (40dB), and peak hold circuit for both left and right channels. The dynamic range of the signal is thus contracted by 40dB to obtain a "peak held" DC voltage.

The output power indicator segments of the FL tube are driven by the HA12010 ICs (one for each channel) equipped with 12 pairs of differential amplifiers. These amplifiers are biased at increasing levels, so each amplifier will commence to operate separately as the input level increases. And since these amplifiers apply the voltages to the output power indicator segments, each successive segment will light up in turn as the input level rises.

The function indicators are lit up as a result of a voltage being applied to the corresponding function indicator segment according to the selected positions of the FUNCTION switch.

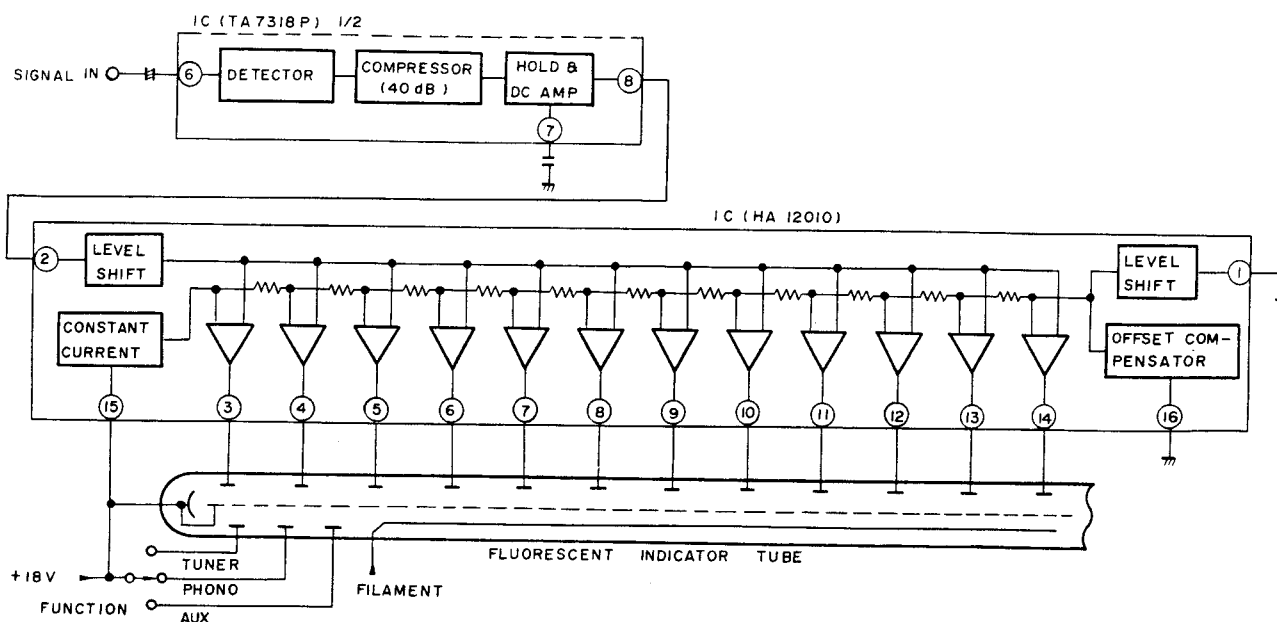

Fig. 4-2 Indicator circuit

## 5. DISASSEMBLY

### Side Covers and Top Cover

1. Remove the four screws (A), and remove the left and right-hand side covers.
2. Remove the two screws (B), and remove the top cover.

### Bottom Plate

Remove the four screws (C).

### Front Panel

Pull off all the knobs, and remove the four nuts (D).

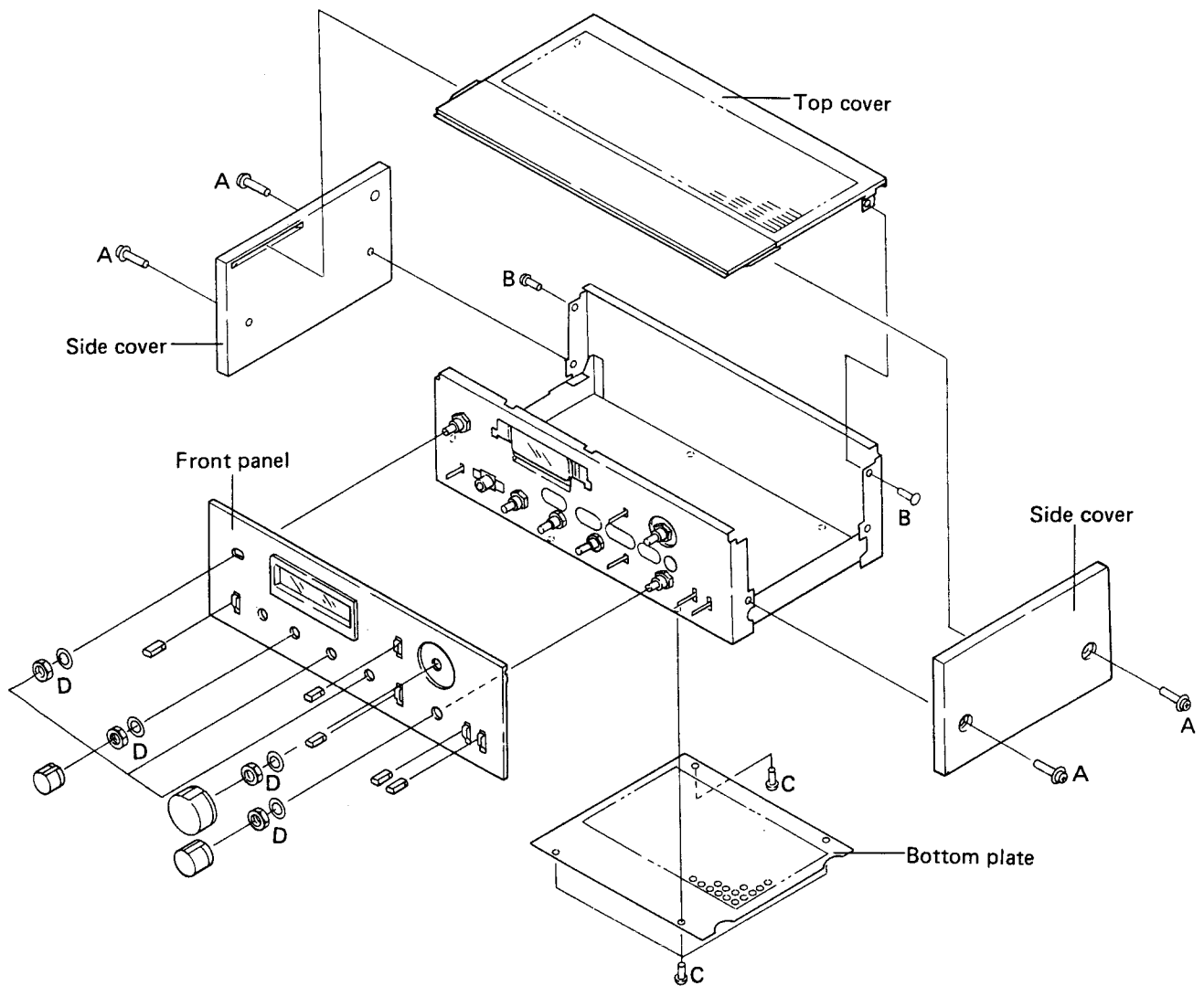



## 6. ADJUSTMENTS

### Idle Current Adjustment

1. Turn the VOLUME control down to minimum level, turn the power on, and wait about 10 minutes.
2. Connect a DC voltmeter to the TP terminals (L ch; TP<sub>2</sub> ⊕ and TP<sub>1</sub> ⊖, R ch; TP<sub>3</sub> ⊕ and TP<sub>4</sub> ⊖) of the GWK-128.
3. Check that the voltage between TP<sub>1</sub> and TP<sub>2</sub> (L ch) lies within the DC 4.4mV-35mV range. Then make a similar check for the R ch (between TP<sub>3</sub> and TP<sub>4</sub>). If the voltage is less than 4.4mV, cut jumper A (L ch), and jumper B (R ch). If the voltage exceeds 35mV, check for circuit failure.

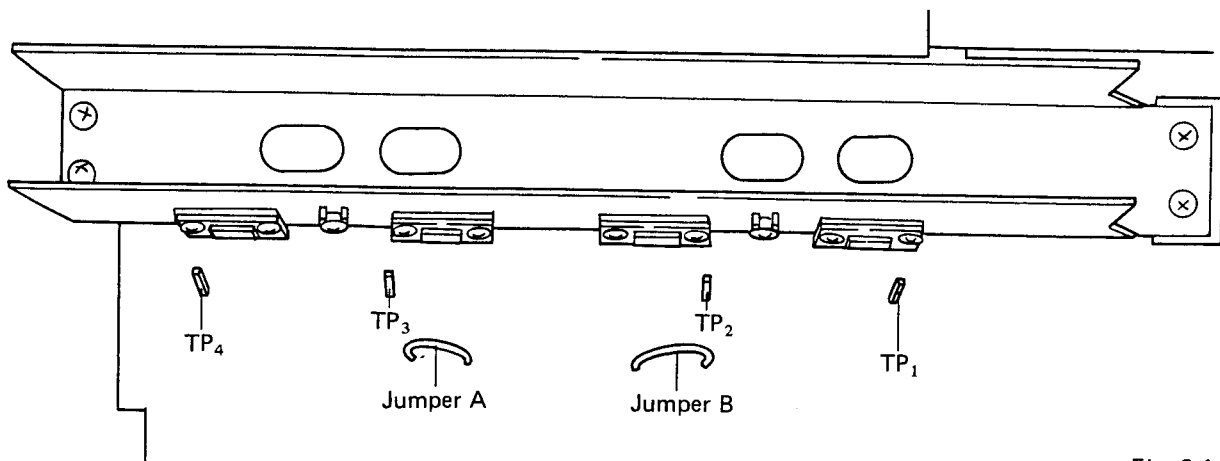

Fig. 6-1

### Output Indicator Adjustment

1. Set the tone control to the flat position.
2. Set the SPEAKERS selector to the A position, and connect an 8Ω resistor and AC voltmeter to the speaker output terminals.
3. Set the FUNCTION switch to the AUX position, and apply a 1kHz, 150mV signal to the AUX input terminals.
4. Adjust the VOLUME control so that the voltage on the output terminals (SPEAKERS) reads 9V (AC).
5. Adjust VR<sub>1</sub> (L ch) and VR<sub>2</sub> (R ch) of the indicator assembly so that the output power indicator reads 10 watts.

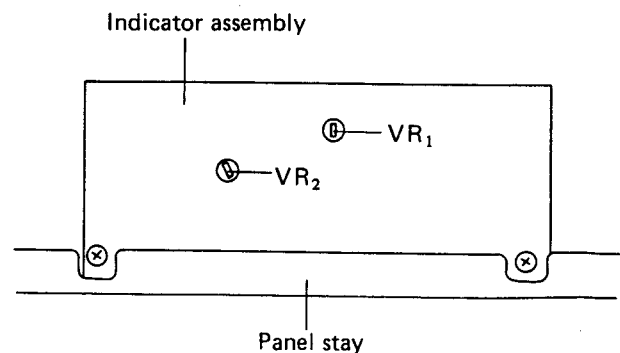

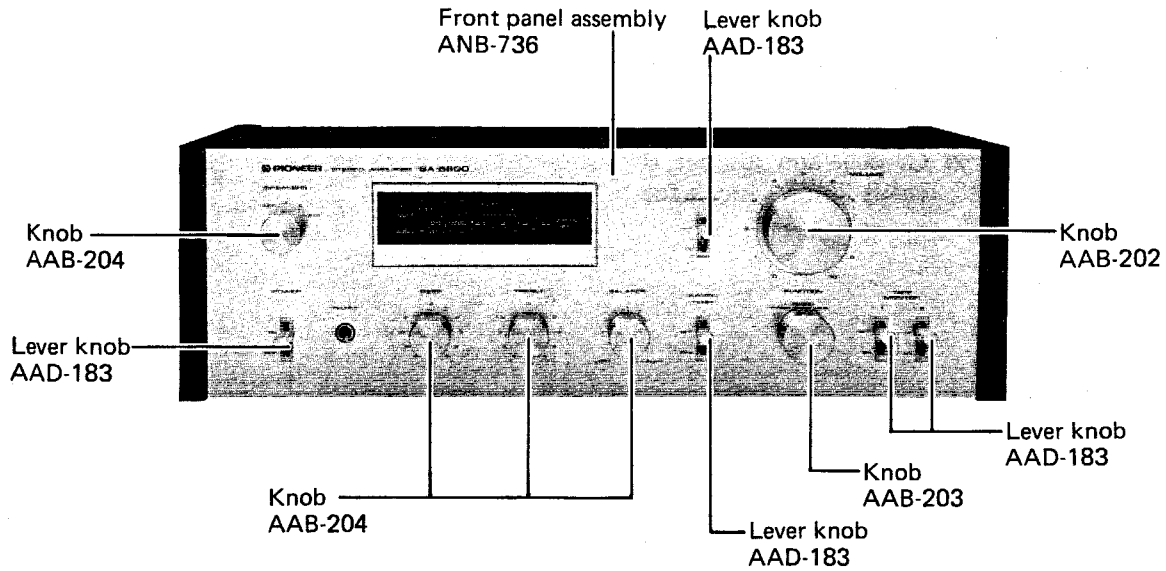

Fig. 6-2

# 7. PARTS LOCATION

- The  mark found on some component parts indicates the importance of the safety factor of the part. Therefore, when replacing, be sure to use parts of identical designation.

Front Panel View



Front View with Panel Removed

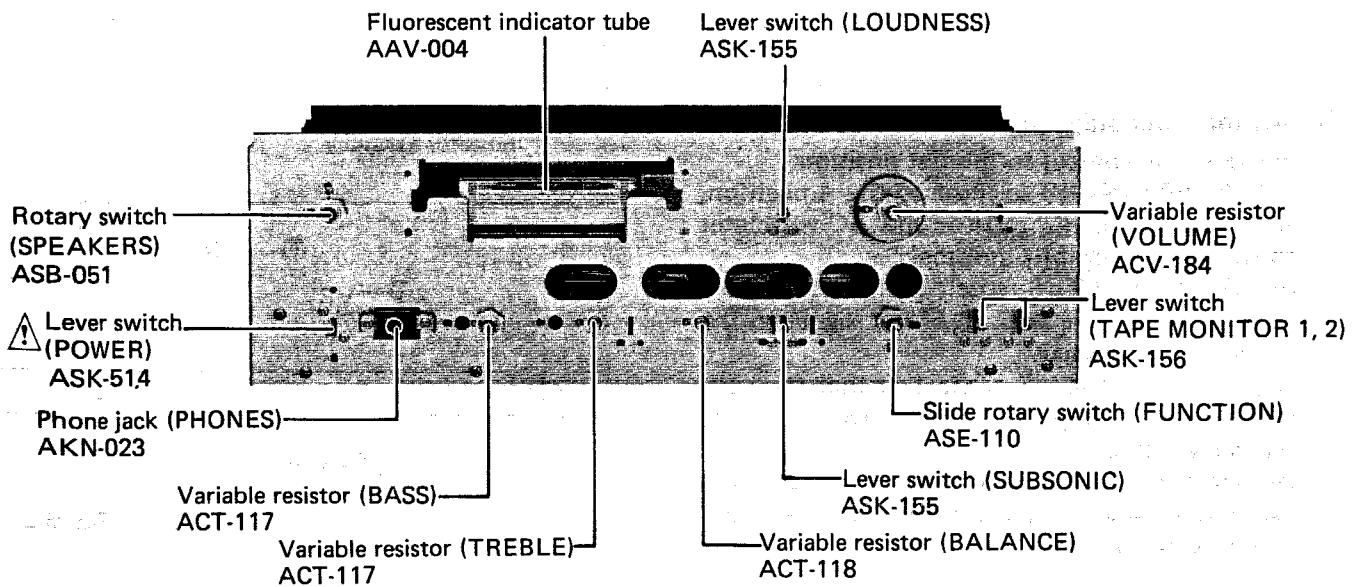

Top View

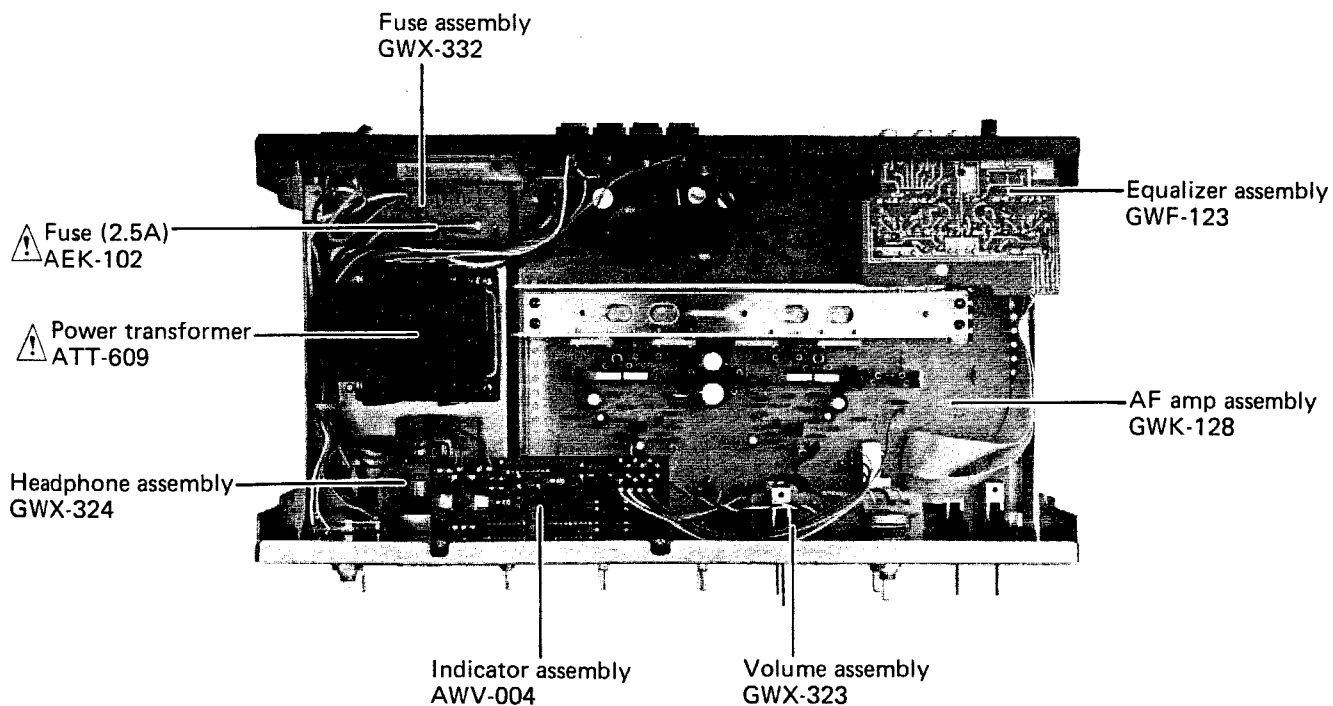

Rear Panel View

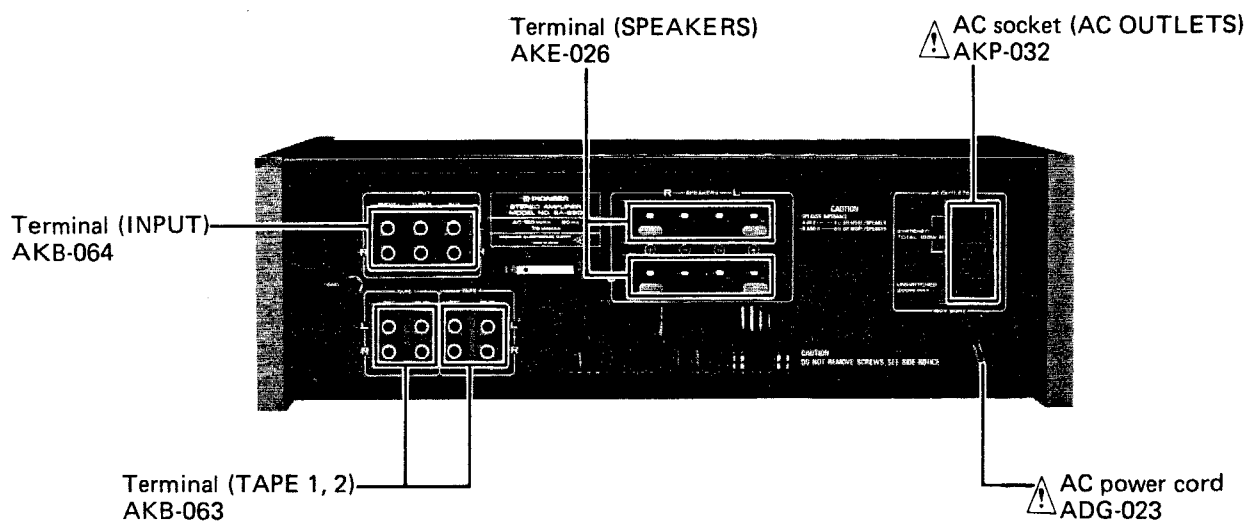

# EXPLODED VIEWS

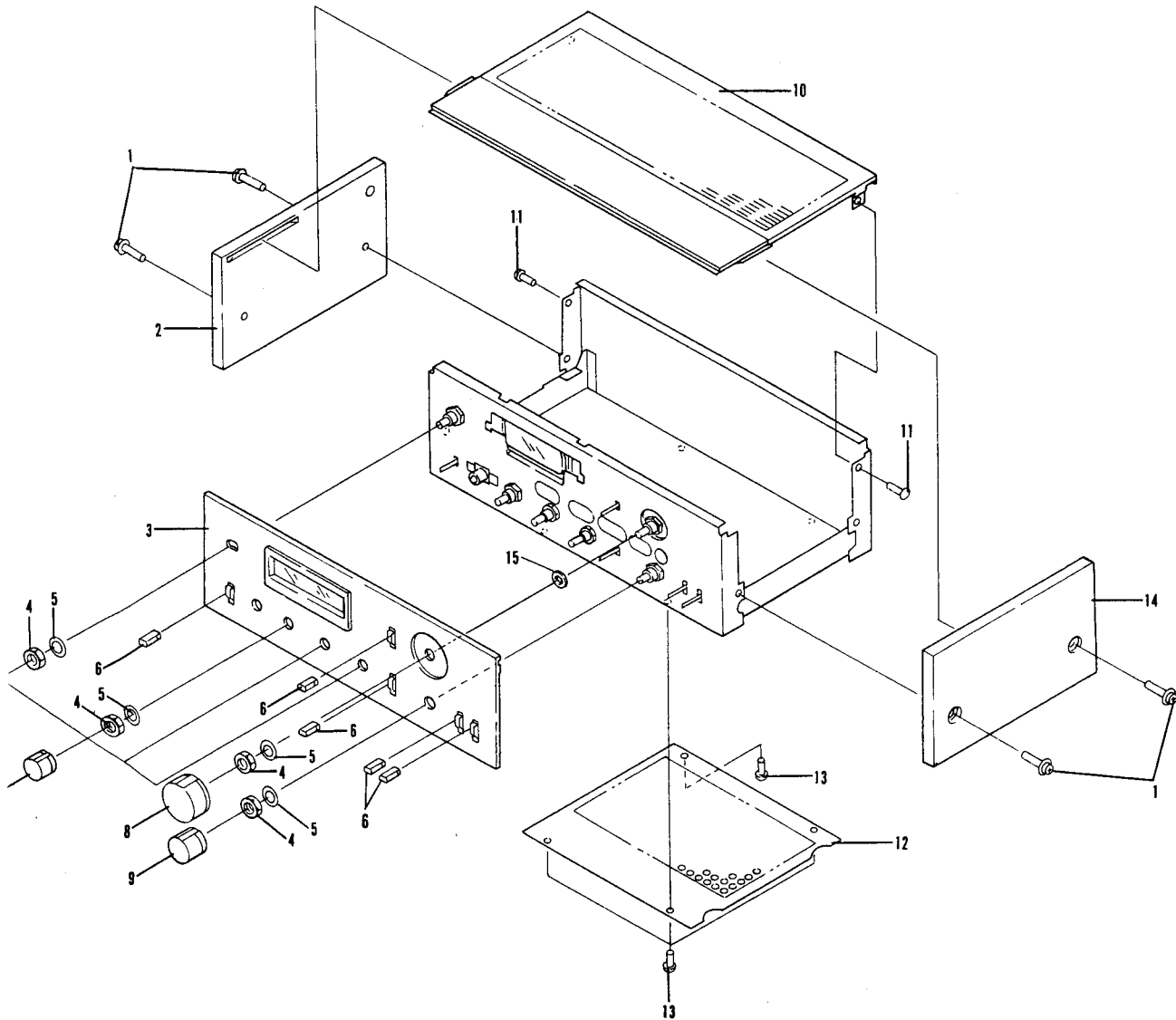

• The  $\triangle$  mark found on some component parts indicates the importance of the safety factor of the part. Therefore, when replacing, be sure to use parts of identical designation.

No.	Part No.	Description	Key No.	Part No.	Description
1.	ABA-209	Screw 4x15	11.	ABA-204	Screw 3x6
2.	AMS-024	Side cover (L)	12.		Bottom plate
3.	ANB-736	Front panel assembly	13.	ABA-048	Screw 3x6
4.	B71-004	Nut M9	14.	AMS-025	Side cover (R)
5.	M45-086	Washer M9	15.	B22-017	Washer
6.	AAD-183	Lever knob			
7.	AAB-204	Knob			
8.	AAB-202	Knob			
9.	AAB-203	Knob			
10.	AMS-023	Top cover			

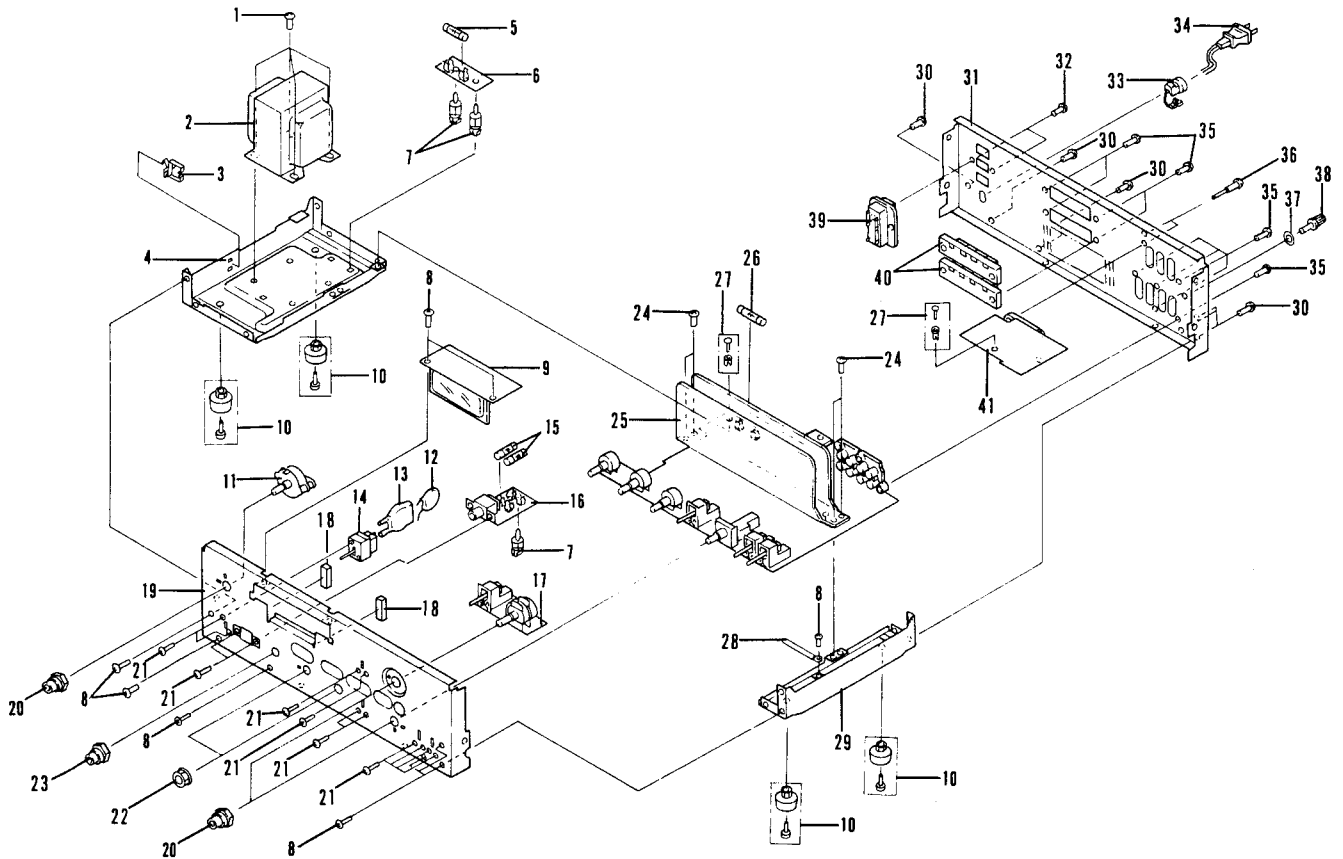

Key No.	Part No.	Description	Key No.	Part No.	Description
	1. ABA-069	Screw 4x8	21.	ABA-025	Screw 3x4
⚠	2. ATT-609	Power transformer	22.	ABN-031	Nut M7
	3.	Wire saddle	23.	ABN-049	Union nut
	4.	Frame	24.	ABA-049	Screw 3x8
⚠	5. AEK-102	Fuse (2.5A)	25.	GWK-128	AF amp assembly
	6. GWX-332	Fuse assembly	⚠	26. AEK-106	Fuse (1A)
	7.	P.C. Board holder	27.	AEC-525	Rivet
	8. ABA-048	Screw 3x6	28.		Cord fixer
	9. AWV-004	Indicator assembly	29.		Frame
	10. AEC-570	Foot assembly	30.	ABA-228	Screw 3x6
	11. ASB-051	Rotary switch (SPEAKERS)	31.		Rear panel
⚠	12. ACG-001	Ceramic capacitor	32.	ABA-240	Screw 3x10
⚠	13. AEC-294	Capacitor cover	33.	AEC-327	Strain relief
⚠	14. ASK-514	Lever switch (POWER)	⚠	34. ADG-023	AC power cord
⚠	15. AEK-100	Fuse (4 A)	35.	ABA-157	Screw 3x8
	16. GWX-324	Headphone assembly	36.	ABA-115	Screw
	17. GWX-323	Volume assembly	37.	ABE-005	Washer
	18.	Cushion	38.		Terminal (GND)
	19.	Panel stay	⚠	39. AKP-032	AC socket (AC OUTLETS)
	20. ABN-050	Union nut	40.	AKE-026	Terminal (SPEAKERS)
			41.	GWF-123	Equalizer assembly

# 9. SCHEMATIC DIAGRAM, P.C. BOARD PATTERNS AND PARTS LIST

**NOTES:**

- When ordering resistors, first convert resistance values into code form as shown in the following examples.

Ex. 1 When there are 2 effective digits (any digit apart from 0), such as 560 ohm and 47k ohm (tolerance is shown by J = 5%, and K = 10%).

```
560Ω   56 x 101  561 ..... RD¼PS 561J
47kΩ   47 x 103  473 ..... RD¼PS 473J
0.5Ω   0R5 ..... RN2H 0R5K
1Ω     010 ..... RSIP 010K
```

Ex. 2 When there are 3 effective digits (such as in high precision metal film resistors).

```
5.62kΩ  562 x 101  5621 ..... RN¼SR 5621F
```

- The **▲** mark found on some component parts indicates the importance of the safety factor of the part. Therefore, when replacing, be sure to use parts of identical designation.

## 9.1 MISCELLANEA

### Miscellaneous Parts

#### SWITCHES

<u>Part No.</u>	<u>Symbol &amp; Description</u>
▲ ASK-514	S1 Lever (POWER)
ASB-051	S2 Rotary (SPEAKERS)

#### FUSES

<u>Part No.</u>	<u>Symbol &amp; Description</u>
▲ AEK-102	FU1 Fuse (2.5A)
▲ AEK-100	FU2, FU3 Fuse (4A)
▲ AEK-106	FU4 Fuse (1A)

#### P.C. BOARD ASSEMBLIES

<u>Part No.</u>	<u>Description</u>
AWV-004	Indicator assembly
GWK-128	AF amp assembly
GWF-123	Equalizer assembly
GWX-323	Volume assembly
GWX-324	Headphone assembly
GWX-332	Fuse assembly

#### OTHERS

<u>Part No.</u>	<u>Symbol &amp; Description</u>
▲ ATT-609	T1 Power transformer
▲ ACG-001	C1 Ceramic capacitor
AKE-026	Terminal (SPEAKERS)
▲ AKP-032	AC socket (AC OUTLETS)

### List of Changed Parts for Factory Modification

List of changed parts information will be furnished whenever necessary and you are requested to amend parts number in this parts list.

<u>Symbol</u>	<u>Part No.</u>	<u>Description</u>

9.2 SCHEMATIC DIAGRAM

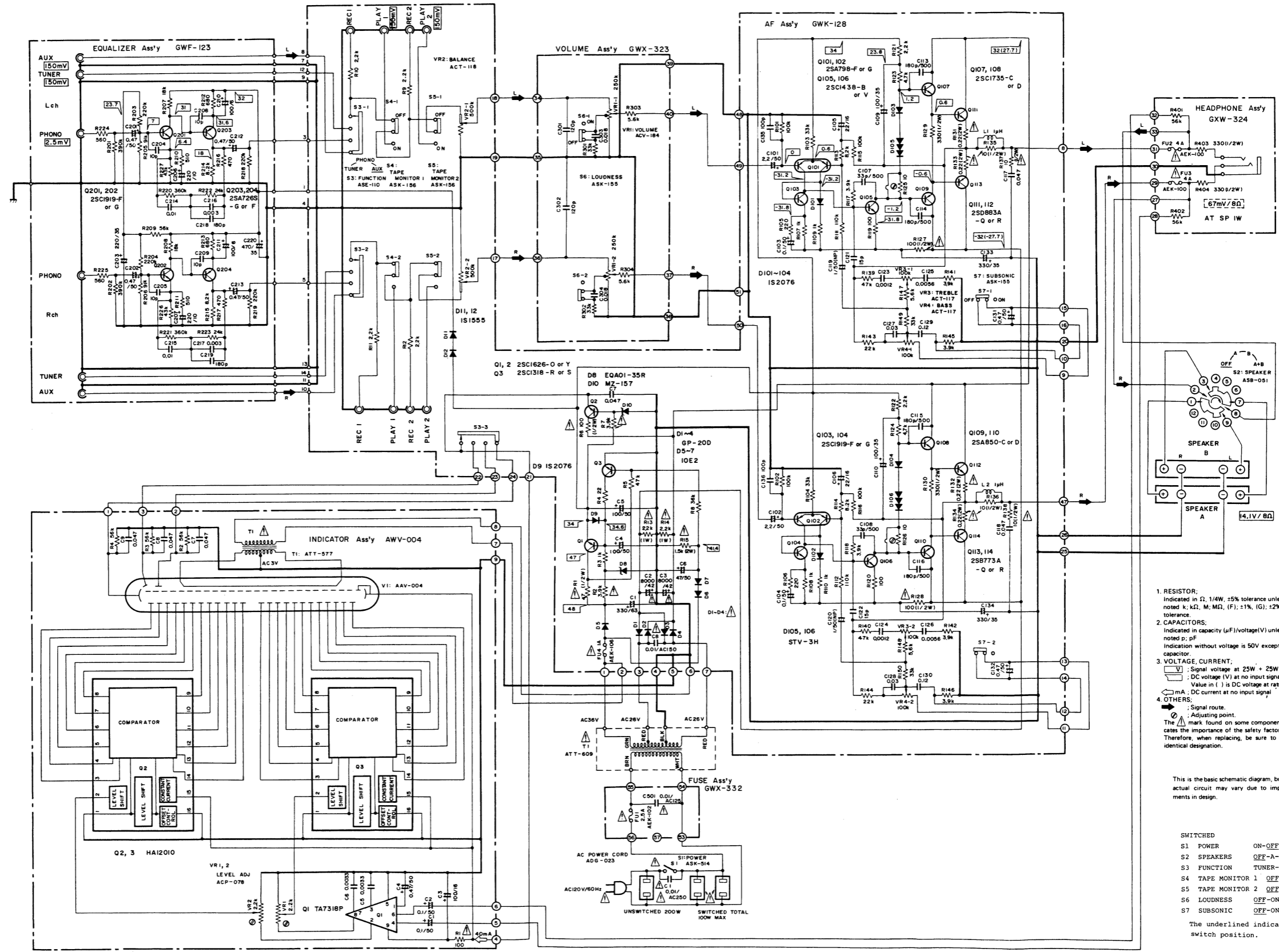

1. RESISTOR:  
Indicated in  $\Omega$ , 1/4W,  $\pm 5\%$  tolerance unless otherwise noted; k: k $\Omega$ , M: M $\Omega$ , (F):  $\pm 1\%$ , (G):  $\pm 2\%$ , (K):  $\pm 10\%$  tolerance.
2. CAPACITORS:  
Indicated in capacity ( $\mu$ F/voltage/V) unless otherwise noted; p: pF  
Indication without voltage is 50V except electrolytic capacitor.
3. VOLTAGE, CURRENT:  
 $\nabla$ : Signal voltage at 25W + 25W  $\Omega$  output  
DC voltage (V) at no input signal  
Value in ( ) is DC voltage at rated power.  
 $\nabla$ : mA, DC current at no input signal.
4. OTHERS:  
 $\rightarrow$ : Signal route.  
 $\triangle$ : Adjusting point.  
The  $\triangle$  mark found on some component parts indicates the importance of the safety factor of the part. Therefore, when replacing, be sure to use parts of identical designation.

This is the basic schematic diagram, but the actual circuit may vary due to improvements in design.

- SWITCHED
- |                   |                 |
|-------------------|-----------------|
| S1 POWER          | ON-OFF          |
| S2 SPEAKERS       | OFF-A-B-A+B     |
| S3 FUNCTION       | TUNER-PHONO-AUX |
| S4 TAPE MONITOR 1 | OFF-ON          |
| S5 TAPE MONITOR 2 | OFF-ON          |
| S6 LOUDNESS       | OFF-ON          |
| S7 SUBSONIC       | OFF-ON          |
- The underlined indicates the switch position.

4

5

6

7

8

9

**NOTE:**  
The indicated semiconductors are representative ones only. Other alternative semiconductors may be used and are listed in the parts list.

**External Appearance of Transistors and ICs**

2SA850  
2SC1735

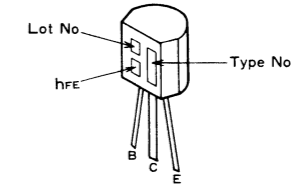

2SC1919

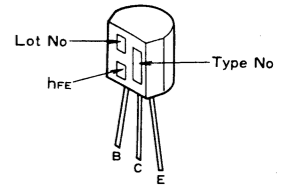

2SA750  
2SC1400

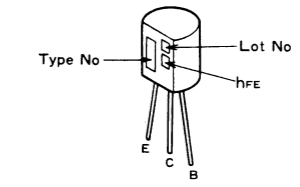

2SC1318

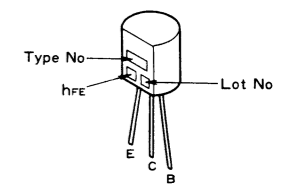

2SA798

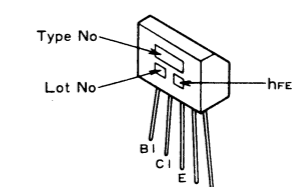

2SC1626

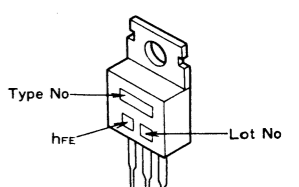

2SA726S

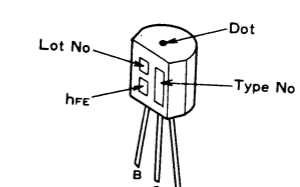

TA7318P

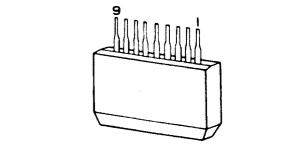

2SB773A  
2SD883A

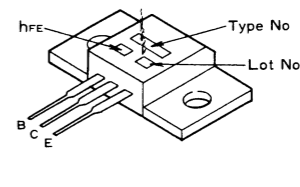

HA12010

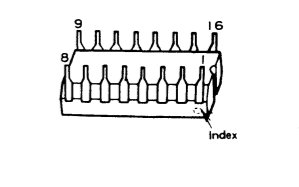

2SC1438

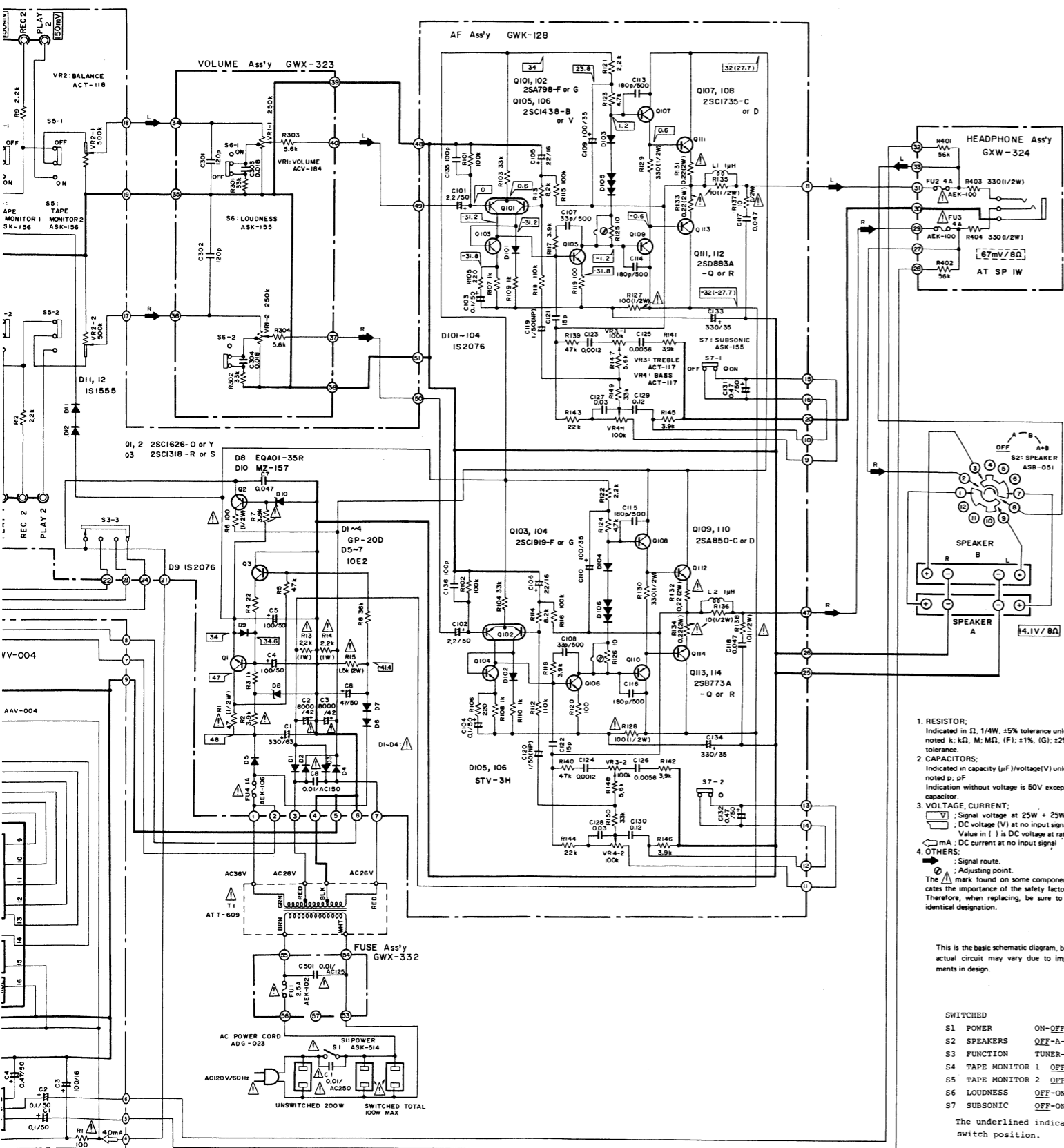
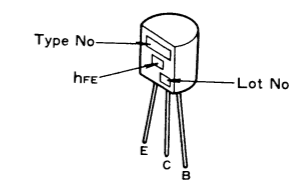

- 1. RESISTOR:**  
Indicated in Ω, 1/W, .15% tolerance unless otherwise noted k; M; MΩ; (F); ±1%; (G); ±2%; (K); ±10% tolerance.
- 2. CAPACITORS:**  
Indicated in capacity (μF)/voltage(V) unless otherwise noted p; pF  
Indication without voltage is 50V except electrolytic capacitor
- 3. VOLTAGE, CURRENT:**  
[Symbol] : Signal voltage at 25W + 25W 8Ω output  
[Symbol] : DC voltage (V) at no input signal  
Value in ( ) is DC voltage at rated power.  
[Symbol] : DC current at no input signal
- 4. OTHERS:**  
[Symbol] : Signal route.  
[Symbol] : Adjusting point.  
The Δ mark found on some component parts indicates the importance of the safety factor of the part. Therefore, when replacing, be sure to use parts of identical designation.

This is the basic schematic diagram, but the actual circuit may vary due to improvements in design.

- SWITCHED**
- S1 POWER ON-OFF
  - S2 SPEAKERS OFF-A-B-A+B
  - S3 FUNCTION TUNER-PHONO-AUX
  - S4 TAPE MONITOR 1 OFF-ON
  - S5 TAPE MONITOR 2 OFF-ON
  - S6 LOUDNESS OFF-ON
  - S7 SUBSONIC OFF-ON
- The underlined indicates the switch position.

4

5

6

7

8

9

A

B

C

D



9.3 P.C. BOARDS CONNECTION DIAGRAM

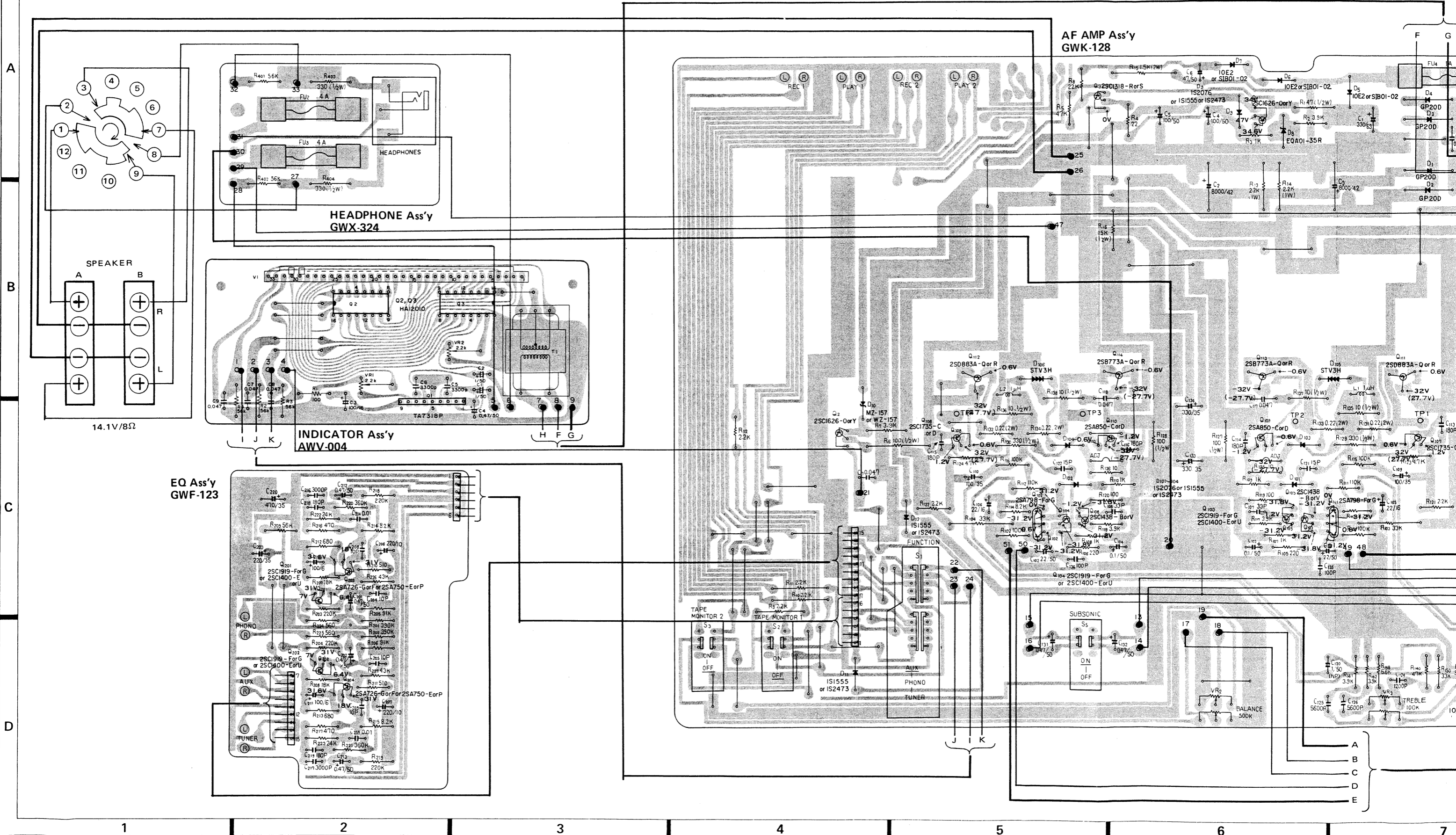

4

5

6

7

8

9

### AF AMP Ass'y GWK-128

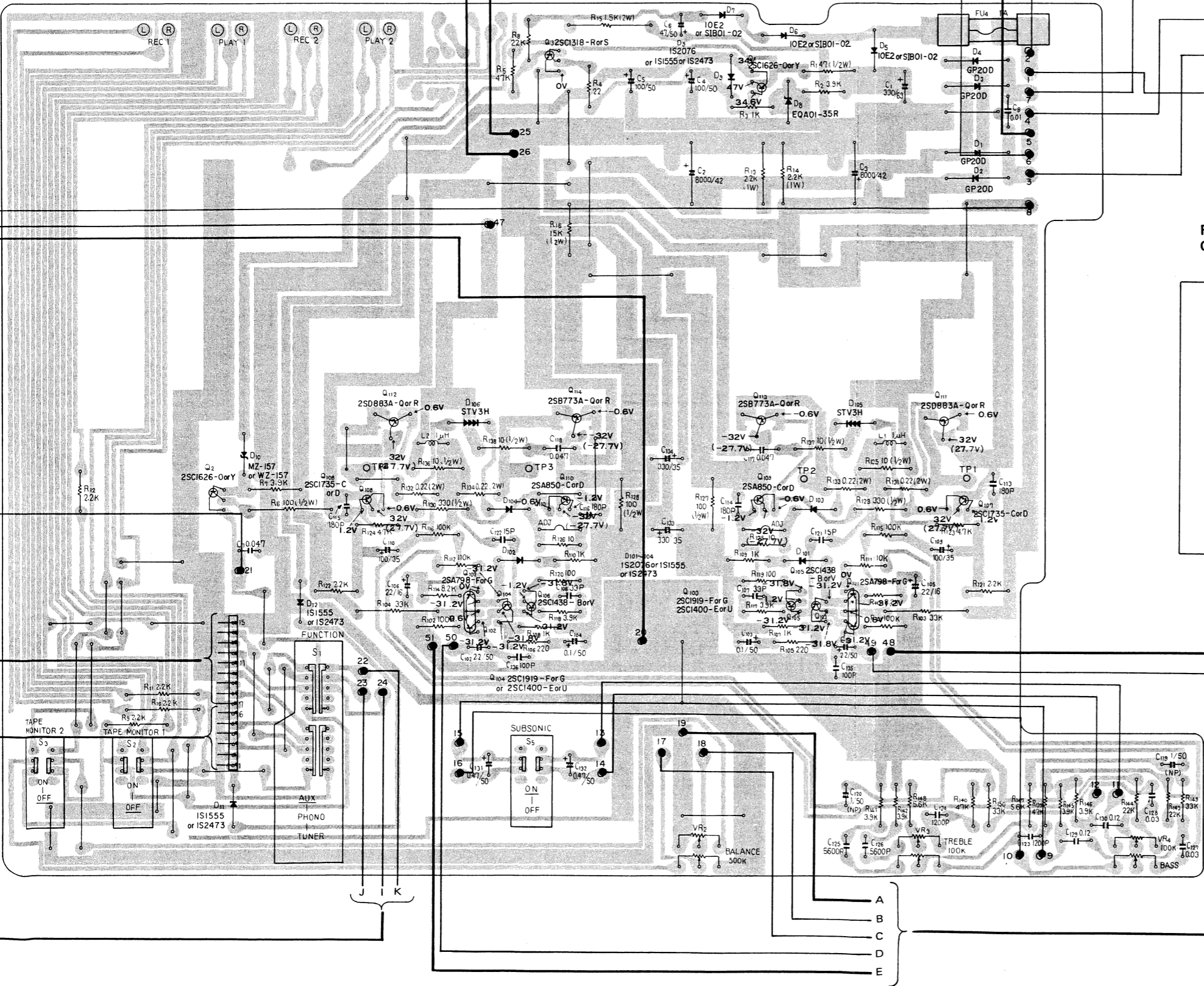

### FUSE Ass'y GWX-332

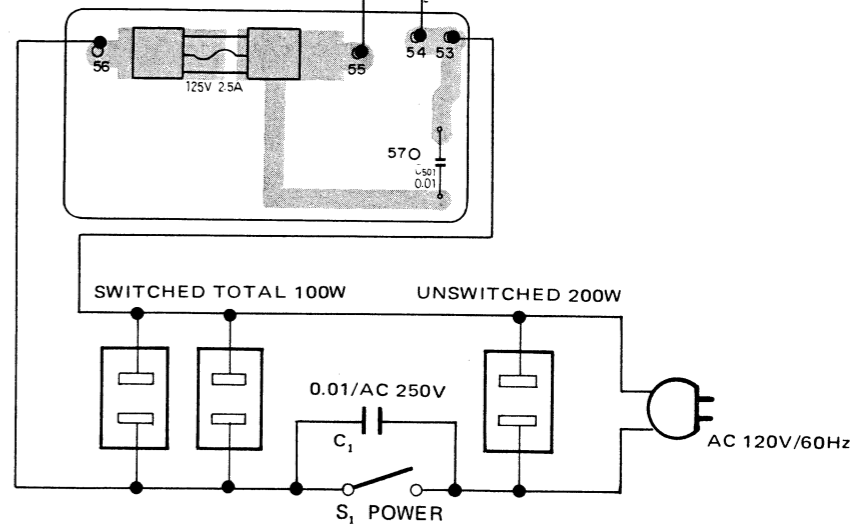

### VOLUME Ass'y GWX-323

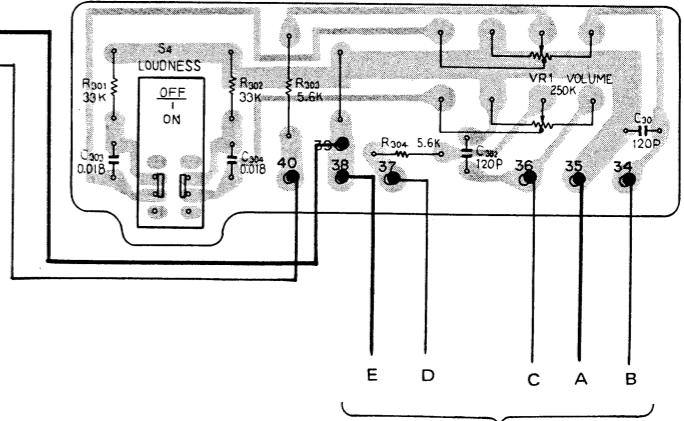

A

B

C

D

4

5

6

7

8

9

## 9.4 PARTS LIST OF P.C. BOARD ASSEMBLIES

## Equalizer Assembly (GWF-123)

## CAPACITORS

Part No.	Symbol & Description
CEANL R47M 50	C201, C202, C212, C213
CEA 221P 35	C203
CEA 221P 10	C206, C207
CEA 101P 6	C210, C211
CEA 471P 35	C220
CCDSL 100F 50	C204, C205, C208, C209
CCDSL 181K 50	C218, C219
CKDYA 302J 50	C216, C217
CQMA 103J 50	C214, C215

Note: When ordering resistors, convert the resistance value into code form, and then rewrite the part no. as before.

## RESISTORS

Part No.	Symbol & Description
RD $\frac{1}{2}$ PM $\square\square\square$ JNL	R201–R206, R210, R211, R220, R221, R226, R227
RD $\frac{1}{2}$ PM $\square\square\square$ J	R207–R209, R214–R219, R222–R225, R212, R213

## SEMICONDUCTORS

Part No.	Symbol & Description
2SC1919 (2SC1400)	Q201, Q202
2SA726S (2SA750)	Q203, Q204

## OTHER

Part No.	Symbol & Description
AKB-064	Terminal (INPUT)

## AF Amp Assembly (GWK-128)

## CAPACITORS

Part No.	Symbol & Description
CEA 331P 63	C1
$\Delta$ ACH-203	C2, C3
CEA 101P 50	C4, C5
CEA 470P 50	C6
CEA 220P 16	C105, C106
CEA 101P 35	C109, C110
CEA 331P 35	C133, C134
CEANL R10M 50	C103, C104
CEANL R47M 50	C131, C132
CEANL 2R2M 50	C101, C102
CEANLNP 010M 50	C119, C120
$\Delta$ ACG-004	C8
CCDSL 150K 50	C121, C122

Part No.	Symbol & Description
CCDSL 330K 50	C107, C108
CCDSL 181K 50	C113–C116
CKDYF 473Z 50	C7, C117, C118
CCDSL 101K 50	C135, C136
CQMA 122J 50	C123, C124
CQMA 562J 50	C125, C126
CQMA 303J 50	C127, C128
CQMA 124J 50	C129, C130

Note: When ordering resistors, convert the resistance value into code form, and then rewrite the part no. as before.

## RESISTORS

Part No.	Symbol & Description
$\Delta$ RD $\frac{1}{2}$ PSF $\square\square\square$ J	R1, R6, R127, R128, R135–R138
RD $\frac{1}{2}$ PM $\square\square\square$ J	R2–R5, R8–R12, R101–R126, R139–R150
$\Delta$ RD $\frac{1}{2}$ PSF $\square\square\square$ J	R7
$\Delta$ RS1P $\square\square\square$ J	R13, R14
$\Delta$ RS2P $\square\square\square$ J	R15
RD $\frac{1}{2}$ PS $\square\square\square$ J	R16, R129, R130
$\Delta$ ACN-039 (ACN-030)	R131–R134
ACT-118	VR2 Variable (BALANCE)
ACT-117	VR3, VR4 Variable (BASS, TREBLE)

## SEMICONDUCTORS

Part No.	Symbol & Description
2SC1626	Q1, Q2
2SC1318	Q3
2SA798	Q101, Q102
2SC1919 (2SC1400)	Q103, Q104
2SC1438	Q105, Q106
*2SC1735-C (2SC1735-D)	Q107, Q108
*2SA850-C (2SA850-D)	Q109, Q110
*hfe of Q107 – Q110 should have the same value.	
*2SD883A-Q (2SD883A-R)	Q111, Q112
*2SB773A-Q (2SB773A-R)	Q113, Q114
*hfe of Q111 – Q114 should have the same value.	
$\Delta$ GP-20D	D1–D4
10E2	D5–D7
(SIB01-02)	
EQA01-35R	D8
1S2076 (1S1555)	D9, D101–D104
(1S2473)	
1S1555 (1S2473)	D11, D12
MZ-157	D10
(WZ-157)	
STV3H-Y	D105, D106

## SWITCHES

Part No.	Symbol & Description	
ASE-110 (ASE-101)	S1	Slide rotaly (FUNCTION)
ASK-156	S2, S3	Lever (TAPE MONITOR 1, 2)
ASK-155	S5	Lever (SUBSONIC)

## OTHERS

Part No.	Symbol & Description	
AKB-063		Terminal (TAPE)
AEC-288		Insulator wafer
AKH-008		Insulator spacer
ABA-187		Screw 2.5x8
ABA-066		Screw 3x8
ABE-052		Insulator washer
ABA-234		Screw 3x12
ABE-046		Washer M3

## Indicator Assembly (AWV-004)

### CAPACITORS

Part No.	Symbol & Description	
CEANL 0R1M 50	C1, C2	
CEA 101P 16	C3	
CEA R47P 50	C4	
CQMA 332K 50	C5, C6	
CKDYF 473Z 50	C7-C9	

*Note: When ordering resistors, convert the resistance value into code form, and then rewrite the part no. as before.*

### RESISTORS

Part No.	Symbol & Description	
RD $\frac{1}{2}$ PMF $\square\square\square$ J	R1	
RD $\frac{1}{2}$ PM $\square\square\square$ J	R2-R4	
ACP-078	VR1, VR2	

## SEMICONDUCTORS

Part No.	Symbol & Description	
TA7318P-A	Q1	
HA12010	Q2, Q3	

## OTHERS

Part No.	Symbol & Description	
AAV-004	V1	Fluorescent indicator tube
△ ATT-577	T1	Heater transformer

## Volume Assembly (GWX-323)

### CAPACITORS

Part No.	Symbol & Description	
CCDSL 121K 50	C301, C302	
CQMA 183K 50	C303, C304	

*Note: When ordering resistors, convert the resistance value into code form, and then rewrite the part no. as before.*

### RESISTORS

Part No.	Symbol & Description	
RD $\frac{1}{2}$ PM $\square\square\square$ J	R301-R304	

## OTHERS

Part No.	Symbol & Description	
ACV-184	VR1	Variable (VOLUME)
ASK-155	S4	Lever (LOUDNESS)

## Headphone Assembly (GWX-324)

*Note: When ordering resistors, convert the resistance value into code form, and then rewrite the part no. as before.*

### RESISTORS

Part No.	Description	
RD $\frac{1}{2}$ PS $\square\square\square$ J	R401, R402	
RD $\frac{1}{2}$ PS $\square\square\square$ J	R403, R404	
AKN-023		Phones jack (PHONES)

## Fuse Assembly (GWX-332)

Part No.	Symbol & Description	
ACG-017 (ACG-003)	C501	Ceramic capacitor

## 10. PACKING

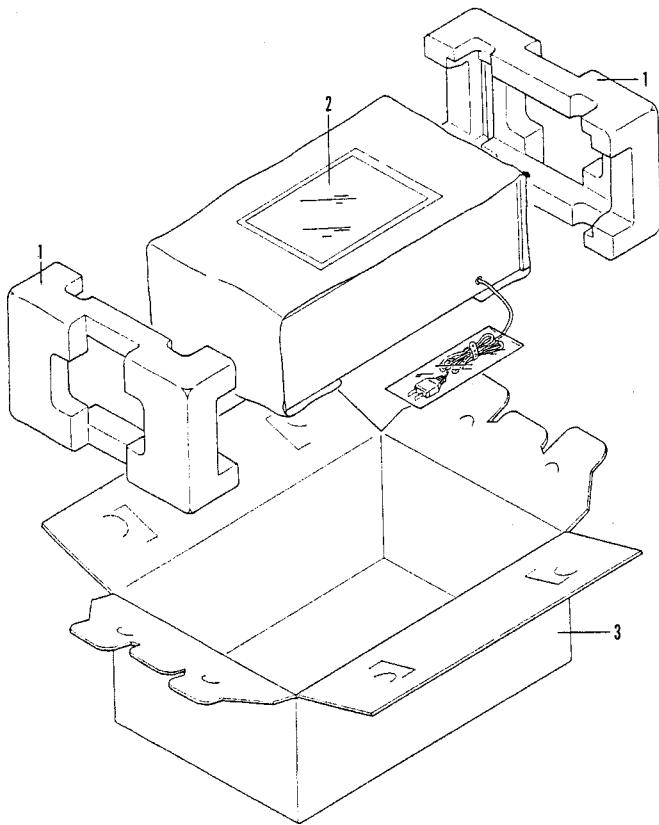

Key No.	Part No.	Description
1.	AHA-188	Side pad
2.	ARB-325	Operating instructions
3.	AHD-693	Packing case

## 11. SUPPLEMENTS FOR MODEL SA-508/KU

Model SA-508/KU is the same as SA-5800/KU with exception of description in this supplements.

### Contrast of Miscellaneous Parts

Symbol	Description	Part No.	
		SA-508/KU	SA-5800/KU
	Front panel assembly	ANB-759	ANB-736
	Bonnet cover	ANE-250	.....
	Top cover	.....	AMS-023
	Side cover (L)	.....	AMS-024
	Side cover (R)	.....	AMS-025
	Packing case	AHD-710	AHD-693
	Side pad	AHA-189	AHA-188
	Operating instructions	ARB-334	ARB-325

**PIONEER ELECTRONIC CORPORATION** 4-1, Meguro 1-Chome, Meguro-ku, Tokyo 153, Japan  
**U.S. PIONEER ELECTRONICS CORPORATION** 85 Oxford Drive, Moonachie, New Jersey 07074, U.S.A.  
**PIONEER ELECTRONIC (EUROPE) N.V.** Luthagen-Haven 9, 2030 Antwerp, Belgium  
**PIONEER ELECTRONICS AUSTRALIA PTY. LTD.** 178-184 Boundary Road, Braeside, Victoria 3185, Australia