



In this photo you can see Model SA-5800

Service Manual

STEREO AMPLIFIER

SA-5800

SA-508

 **PIONEER®**

9.2 SCHEMATIC DIAGRAM

A

B

C

D

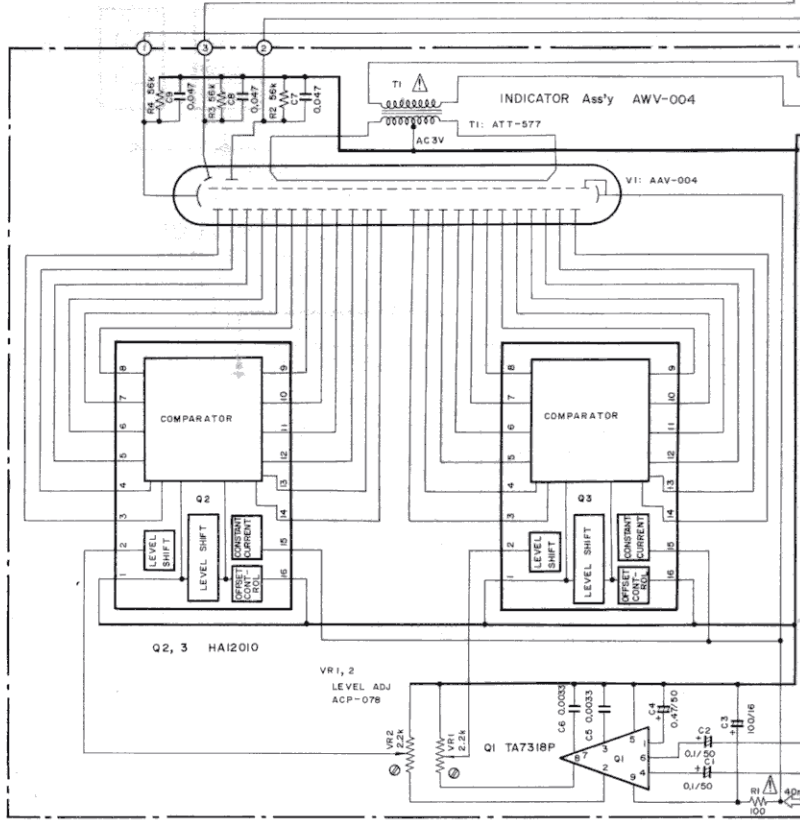
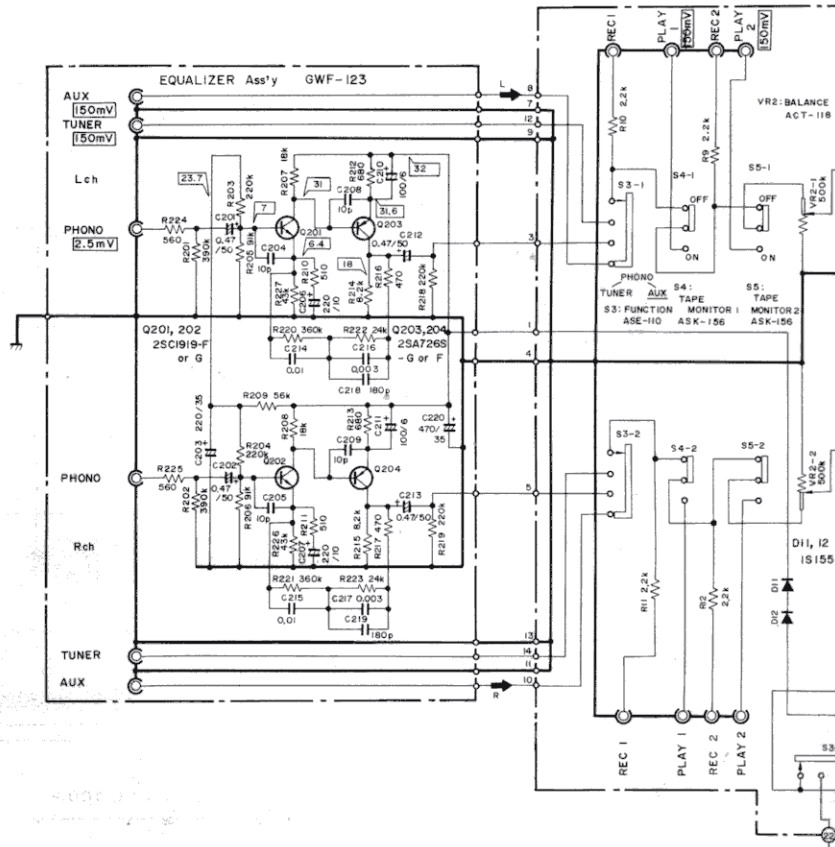

1

2

3

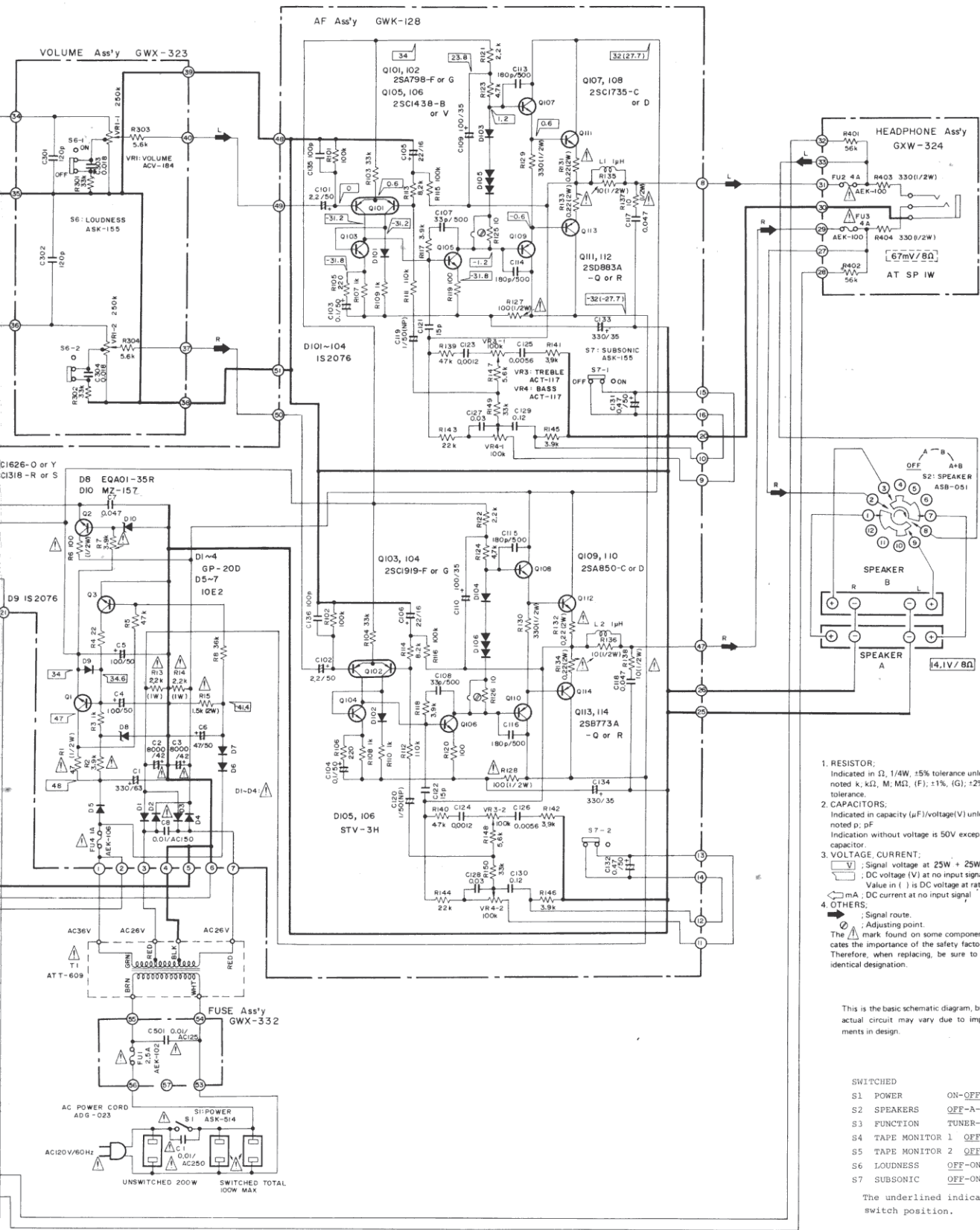

1. RESISTOR:
Indicated in Ω, 1/4W, ±5% tolerance unless otherwise noted k, kΩ, M, MΩ, (F); ±1%, (G); ±2%, (K); ±10% tolerance.
2. CAPACITORS:
Indicated in capacity (μF)/voltage(V) unless otherwise noted p, pF
Indication without voltage is 50V except electrolytic capacitor.
3. VOLTAGE, CURRENT:

	: Signal voltage at 25W + 25W 8Ω output
	: DC voltage (V) at no input signal
	: Value in () is DC voltage at rated power.
	: mA DC current at no input signal
4. OTHERS:

	: Signal route.
	: Adjusting point.

The mark found on some component parts indicates the importance of the safety factor of the part. Therefore, when replacing, be sure to use parts of identical designation.

This is the basic schematic diagram, but the actual circuit may vary due to improvements in design.

SWITCHED	
S1 POWER	ON-OFF
S2 SPEAKERS	OFF-A-B-A+B
S3 FUNCTION	TUNER-PHONO-AUX
S4 TAPE MONITOR 1	OFF-ON
S5 TAPE MONITOR 2	OFF-ON
S6 LOUDNESS	OFF-ON
S7 SUBSONIC	OFF-ON

The underlined indicates the switch position.