

Quick Installation Guide

2.4 GHz Cell Station Unit

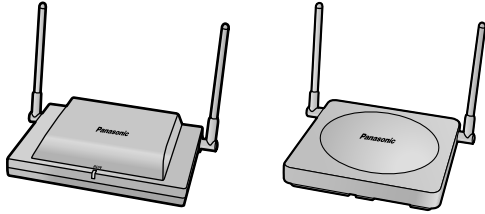

Model No. KX-T0141
 KX-TDA0142
 KX-T0151
 KX-TDA0152

Thank you for purchasing a Panasonic 2.4 GHz Cell Station Unit.
Please read this manual carefully before using this product and save this manual for future use.

Important Information

SAVE THESE INSTRUCTIONS

Safety Notices

Please observe the safety notices in this manual in order to avoid danger to users or other people, and prevent damage to property.

The notices are classified as follows, according to the severity of injury or damage:

<u>WARNING</u>	This notice means that misuse could result in death or serious injury.
<u>CAUTION</u>	This notice means that misuse could result in injury or damage to property.

WARNING

SAFETY REQUIREMENTS

- The product must only be installed and serviced by qualified service personnel. The product should be used as-is from the time of purchase; it should not be disassembled or modified. Disassembly or modification can cause a fire, electric shock, or damage to the product.
- Make sure that the wall that the unit will be attached to is strong enough to support the unit (approx. 310 g [11 oz]). If not, it is necessary for the wall to be reinforced.
- Only use the wall-mounting equipment (screws, washers, wall mounting plate) included with the unit.
- When this product is no longer in use, make sure to detach it from the wall.
- Do not connect or disconnect the telephone cord with wet hands.
- Disconnect the unit from the telephone cord, and contact the dealer if:
 - The unit is exposed to rain, water, or any other liquid.
 - The unit is dropped or damaged.
 - Internal components are exposed due to damage.
 - The unit does not operate properly.
 - Performance deteriorates.
- Disconnect the unit from the telephone cord if the unit emits smoke, an abnormal smell, or makes unusual noise. These conditions can cause fire or electric shock. Confirm that smoke has stopped and contact an authorized service center.
- Do not touch the unit, or telephone cord during a lightning storm.
- Do not allow anything to rest on the telephone cord. Do not locate this unit where the telephone cord may be stepped on or tripped on.

CAUTION

SAFETY REQUIREMENTS

- The CS should be kept free of dust, moisture, high temperature (more than 40 °C [104 °F]), low temperature (less than 0 °C [32 °F]), and vibration, and should not be exposed to direct sunlight.
- The CS should not be placed outdoors (use indoors).
- The CS should not be placed near high-voltage equipment.
- The CS should not be placed on a metal object.
- Systems using 2.4 GHz ISM (Industrial, Scientific and Medical) band may interfere with the Panasonic wireless system. Examples of such systems are cordless telephones, wireless LAN, Home RF, microwave ovens and other ISM devices. These systems may cause minor noise.

- When driving the screws into the wall, be careful to avoid touching any metal laths, wire laths or metal plates in the wall.
- To prevent malfunction, deformity, overheating, rust, and discoloration, do not install or place equipment in the following types of locations:
 - Locations where air ventilation is poor.
 - Locations that may be exposed to sulphurous gas, such as near hot springs.
 - Near devices that emit heat, such as heaters.
 - Near devices that emit electromagnetic noise, such as radios or televisions.
 - Near devices that emit high-frequency noise, such as sewing machines or welders.
- Do not stretch or bend the cables. Also, do not allow anything to rest on the cables.
- Use cables that are fire-resistant or fireproof.
- The CS and the cables should never be placed near or over a radiator or other heat source.
- Do not bundle cables that are connected to the CS with the AC power cords of machines located nearby.
- Make sure the cables are securely fastened to the wall.
- Disconnect the telephone cord from the unit before cleaning. Clean the unit with a soft, dry cloth. Do not use liquid, aerosol cleaners, abrasive powders, or chemical agents to clean the unit.
- When left unused for a long period of time, disconnect the unit from the telephone cord.
- **Medical**—consult the manufacturer of any personal medical devices, such as pacemakers, to determine if they are adequately shielded from external RF (radio frequency) energy. (The unit operates in the frequency range of 2400 MHz to 2483 MHz, and the output peak power level is less than 0.25 W.) Do not use the unit in health care facilities if any regulations posted in the area instruct you not to do so. Hospitals or health care facilities may be using equipment that could be sensitive to external RF (radio frequency) energy.

Notice

SAFETY REQUIREMENTS

- Before connecting the unit, confirm that the unit supports the intended operating environment.
- If the unit does not operate properly, disconnect the telephone cord, then connect again.
- The unit may not operate in the event of a power failure.
- Do not move the unit while it is in use.
- Satisfactory operation, interoperability, and compatibility cannot be guaranteed with all equipment connected to the unit, nor with all services provided by telecommunications providers over networks connected to the unit.

SECURITY REQUIREMENTS

- Privacy of communications may not be ensured when using the wireless systems.

Additional Information

F.C.C. REQUIREMENTS AND RELEVANT INFORMATION

CAUTION

Any changes or modifications not expressly approved by the party responsible for compliance could void the user's authority to operate this device.

Note

This equipment has been tested and found to comply with the limits for a Class B digital device, pursuant to Part 15 of the FCC Rules. These limits are designed to provide reasonable protection against harmful interference in a residential installation. This equipment generates, uses, and can radiate radio frequency energy and, if not installed and used in accordance with the instructions, may cause harmful interference to radio communications. However, there is no guarantee that interference will not occur in a particular installation. If this equipment does cause harmful interference to radio or television reception, which can be determined by turning the equipment off and on, the user is encouraged to try to correct the interference by one or more of the following measures:

- Reorient or relocate the receiving antenna.
- Increase the distance between the equipment and receiver.
- Connect the equipment to an outlet on a circuit different from that to which the receiver is connected.
- Consult the dealer or an experienced radio/TV technician for help.

Some wireless telephones operate at frequencies that may cause interference to nearby TVs and VCRs. To minimize or prevent such interference, the base of the wireless telephone should not be placed near or on top of a TV or VCR. If interference is experienced, move the wireless telephone further away from the TV or VCR. This will often reduce, or eliminate, interference.

RF Exposure Warning:

This product complies with FCC radiation exposure limits set forth for an uncontrolled environment. To comply with FCC RF exposure requirements, this product must be installed and operated in accordance with the provided instructions. The installed unit requires a minimum 20 cm (8 inches) of spacing between the antenna and a person's body (excluding hands, wrists and feet) during wireless modes of operation.

This transmitter must not be co-located or operated in conjunction with any other antennas or transmitters.

Table of Contents

- 1 Overview6**
- 2 Procedure Overview9**
- 3 Site Planning11**
- 4 Before Site Survey15**
- 5 Site Survey19**
- 6 After Site Survey23**
- 7 Connecting a Cell Station to the PBX24**
- 8 Wall Mounting34**
- 9 Troubleshooting39**

1 Overview

Names and Locations

KX-T0151/KX-TDA0152

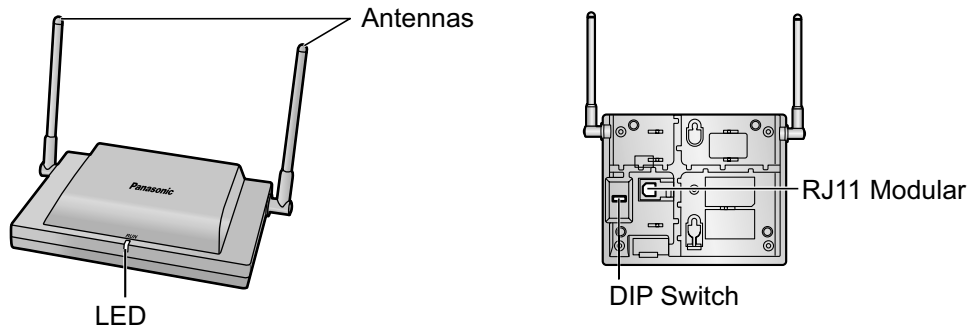

KX-T0141/KX-TDA0142

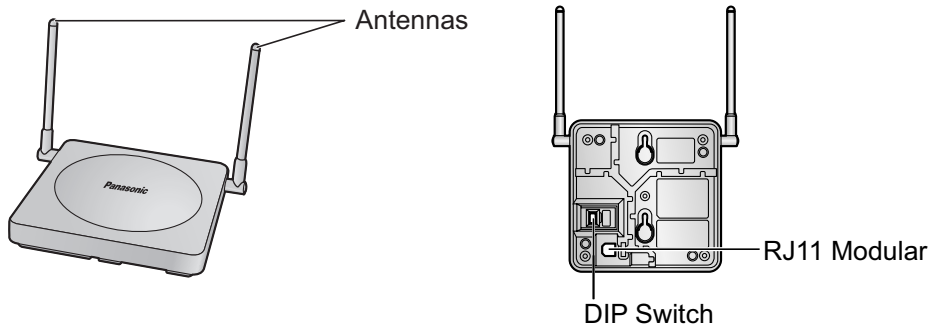

LED Indications (KX-T0151/KX-TDA0152)

Indication	Color	Description
STATUS	Green/Red	<p>CS status indication</p> <ul style="list-style-type: none"> • OFF: Power Off • Green ON: Stand-by (no active calls) • Slow Green Flashing (60 times per minute): Talk (active calls) • Moderate Green Flashing (120 times per minute): Busy • Red ON: Fault (includes Initialization) • Red Flashing (60 times per minute): Out of Service/Starting up <p>CS status indication during the site survey</p> <ul style="list-style-type: none"> • Red ON: The CS is connected to an AC adaptor/battery box. • Red Flashing (60 times per minute): The CS is connected to the PBX.

Maximum Number of Calls

Cell Stations (CSs) determine the area covered by the wireless system. The number of calls that can be made simultaneously through each CS varies depending on the model, as follows:

Cell Station	Maximum Calls	Compatible Portable Station
KX-T0151	2	<ul style="list-style-type: none"> • KX-TD7684 • KX-TD7694 • KX-TD7680 • KX-TD7690
KX-TDA0152	3	
KX-T0141	2	
KX-TDA0142	3	

Note

For more details about the Portable Station (PS), refer to the Operating Instructions of the PS.

Maximum Number of CSs Supported by PBX

Notice

The CSs are for connection to specified Panasonic PBXs only.

The following number of CSs can be supported by each PBX.

PBX	Connected via	Maximum Number			
		KX-T0151	KX-TDA0152	KX-T0141	KX-TDA0142
KX-TAW848	<ul style="list-style-type: none"> • Hybrid Ports • HLC card 	4	-	4	-
KX-TDA50 (with Additional AC Adaptor)	<ul style="list-style-type: none"> • Super Hybrid Ports • HLC card • DLC card 	8	-	8	-
KX-TDA100/ KX-TDA200	<ul style="list-style-type: none"> • DHLC card • DLC card 	32	-	32	-
	<ul style="list-style-type: none"> • CSIF card 	-	32	-	32
KX-TDA600	<ul style="list-style-type: none"> • DHLC card • DLC card 	128	-	128	-
	<ul style="list-style-type: none"> • CSIF card 	-	128	-	128
KX-TDE100/ KX-TDE200	<ul style="list-style-type: none"> • DHLC card • DLC card 	32	-	32	-
	<ul style="list-style-type: none"> • CSIF card 	-	32	-	32
KX-TDE600	<ul style="list-style-type: none"> • DHLC card • DLC card 	128	-	128	-
	<ul style="list-style-type: none"> • CSIF card 	-	128	-	128
KX-NCP500	<ul style="list-style-type: none"> • DHLC card • DLC card 	4	-	4	-

PBX	Connected via	Maximum Number			
		KX-T0151	KX-TDA0152	KX-T0141	KX-TDA0142
KX-NCP1000	<ul style="list-style-type: none"> DHLC card DLC card 	8	-	8	-

Required Distances between Equipment

CAUTION

Maintain the distances listed below between equipment in order to prevent noise, interference or the disconnection of a conversation. (The distance may vary depending on the environment.)

Equipment	Distance
CS and office equipment such as a computer, telex, fax machine, etc., or microwaves	More than 2 m (6 ft 7 in)
CS and PS	More than 1 m (3 ft 3 in)
Each CS	More than 15 m (49 ft)
Each PS	More than 0.5 m (1 ft 8 in)
PBX and CS	More than 2 m (6 ft 7 in)

Notice

The required distance between CSs may vary depending on the environment of the installation site and conditions in which the wireless system is used. Conduct a site survey to determine the appropriate distance.

RF Specification

Item	Description
Frequency Band	2400 MHz to 2483 MHz
Transmission Output	Peak 0.25 W

CAUTION

- The CS should be kept free of dust, moisture, high temperature (more than 40 °C [104 °F]), low temperature (less than 0 °C [32 °F]), and vibration, and should not be exposed to direct sunlight.
- The CS should not be placed outdoors (use indoors).
- The CS should not be placed near high-voltage equipment.
- The CS should not be placed on a metal object.
- Systems using 2.4 GHz ISM (Industrial, Scientific and Medical) band may interfere with the Panasonic wireless system. Examples of such systems are cordless telephones, wireless LAN, Home RF, microwave ovens and other ISM devices. These systems may cause minor noise.

Notice

Please take into consideration the distance between the CSs when site planning. Please consult a certified dealer for details.

2 Procedure Overview

When connecting the wireless system, use extreme care in conducting the site survey. An incorrectly performed site survey can result in poor service area, frequent noise, and disconnection of calls.

1. Investigate the installation site

Refer to "3 Site Planning".

- a. Obtain a map of the CS installation site.
- b. Identify the service area required by the user on the map.
- c. Plan the location of each CS, taking account of distance, building materials, etc.

2. Prepare for site survey

Refer to "4 Before Site Survey".

- a. Assign a CS number to each CS by setting the DIP switches on the back of the CS.
- b. Supply electricity to each CS using an AC adaptor/battery box or by connecting them to the PBX.
- c. Install each CS temporarily as planned.

Note

- Install at least 2 m (6 ft 7 in) above the floor.
- Place the antennas so that they are pointing in directions that are 90 degrees apart (for antenna diversity).

3. Conduct the site survey

Refer to "5 Site Survey".

- a. Test the radio signal strength using the PS.
Confirm that the radio signal strength level is "12" near the CS.

Using the KX-TD7684/KX-TD7694

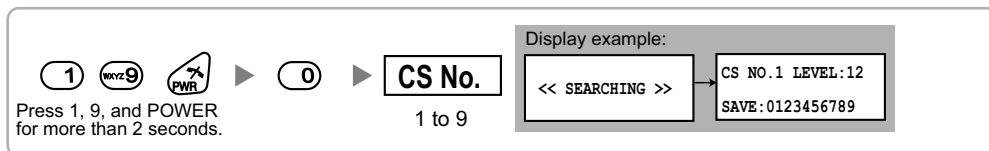

Using the KX-TD7680

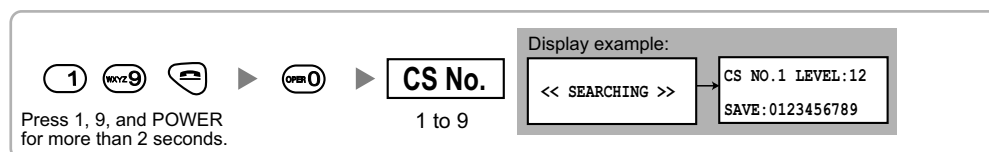

Using the KX-TD7690

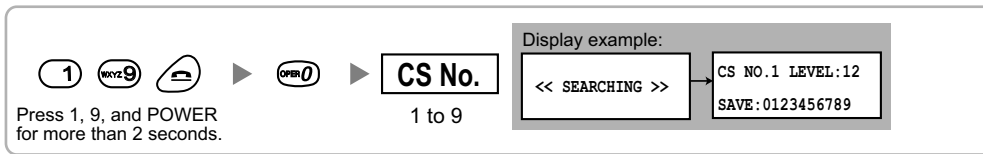

- b. By walking away from the CS with the PS, check the radio signal strength. The radio signal strength weakens as you walk away from the CS.
- c. Map the CS coverage area at radio signal strength levels "3" and "8".
- d. Make sure that adjacent CS coverage areas overlap where the radio signal strength level is "8" by at least 5 m (16 ft).
- e. Make sure that the radio signal strength level is greater than "3" at any location within the service area required by the user.

4. Finish the site survey

Refer to "6 After Site Survey".

- a. Turn off the PS.
- b. Stop supplying power, and return all DIP switches of each CS to the OFF position.

5. Connect the CS and PS to the PBX and test the operation

Refer to "7 Connecting a Cell Station to the PBX".

- a. Connect the CSs to the PBX.
- b. Register the PSs to the PBX.
- c. Walk around the service area while having a conversation using a registered PS. If noise is frequent or conversations disconnect, relocate the CSs or install an additional CS.

6. Mount the CS on the wall

Refer to "8 Wall Mounting".

- a. If there are no problems in testing, mount the CS on the wall.

3 Site Planning

Choosing the best site for the CS requires careful planning and testing of essential areas. The best location may not always be convenient for installation. Read the following information before installing the unit.

Understanding Radio Waves

Characteristics of Radio Waves

The transmission of radio waves and the CS coverage area depend on the structure and materials of the building.

Office equipment, such as computers and fax machines, can interfere with radio waves. Such equipment may create noise or interfere with the performance of the PS.

The illustration below shows the special transmitting patterns of radio waves.

1. Radio waves are reflected by objects made of materials such as metal.
2. Radio waves are diffracted by objects such as metallic columns.
3. Radio waves penetrate objects made of materials such as glass.

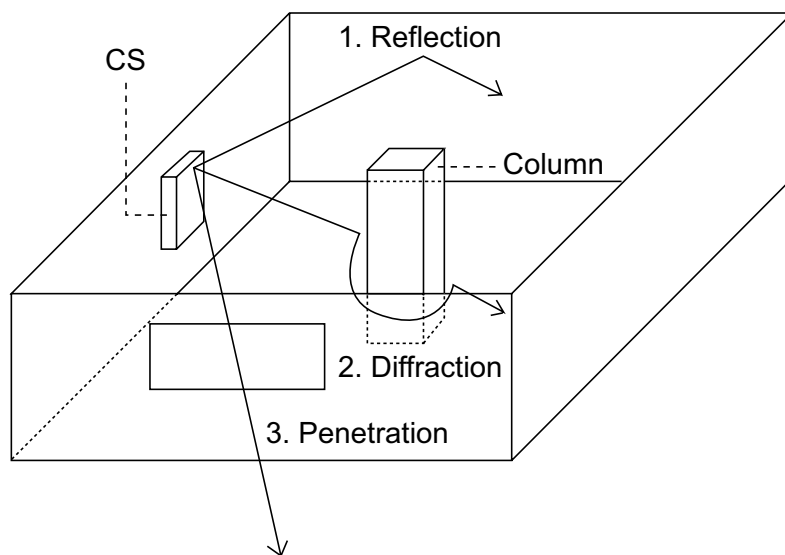

Relationships between Radio Waves and Building Structure and Materials

- The CS coverage area is affected more by the building materials and their thickness than the number of obstacles.
- Radio waves tend to be reflected or diffracted by conductive objects and rarely penetrate them.
- Radio waves tend to penetrate insulated objects and are rarely reflected by them.
- Radio waves penetrate thin objects more than thick objects.
- The table below shows the transmission tendency of radio waves when they reach objects made from various materials.

Object	Material	Transmission Tendency
Wall	Concrete	The thicker they are, the less radio waves penetrate them.
	Ferroconcrete	Radio waves can penetrate them, but the more iron there is, the more radio waves are reflected.
Window	Glass	Radio waves usually penetrate them.
	Glass with wire net	Radio waves can penetrate them, but tend to be reflected.
	Glass covered with heat-resistant film	Radio waves are weakened considerably when they penetrate windows.
Floor	Ferroconcrete	Radio waves can penetrate them, but the more iron there is, the more radio waves are reflected.
Partition	Steel	Radio waves are reflected and rarely penetrate them.
	Plywood, Glass	Radio waves usually penetrate them.
Column	Ferroconcrete	Radio waves can penetrate them, but the more iron there is, the more radio waves tend to be reflected or diffracted.
	Metal	Radio waves tend to be reflected or diffracted.
Cabinet	Steel	Radio waves are usually reflected or diffracted, and rarely penetrate them.
	Wood	Radio waves can penetrate them, but they are weakened.

CS Coverage Area

The example below shows the size of the coverage area of 1 CS if it is installed in an area with no obstacles.

Note

Radio signal strength levels are measured during the site survey (refer to "5 Site Survey").

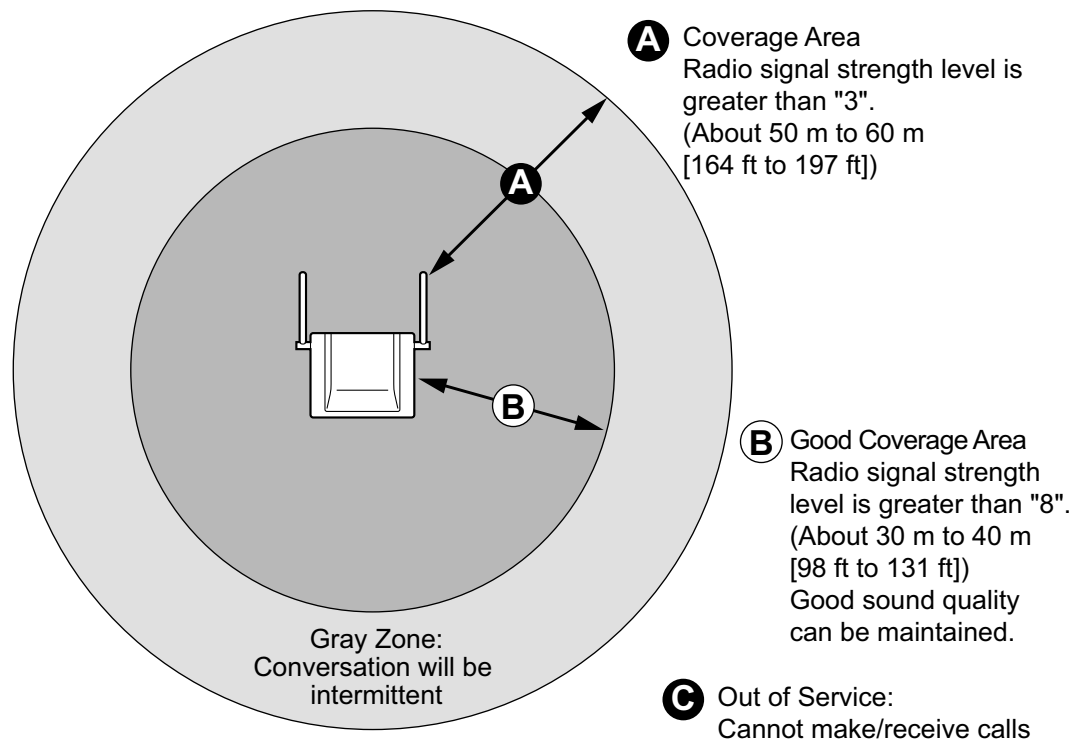

Radio Signal Strength Levels

Level: 11 to 12		Better
Level: 08 to 10		Good
Level: 03 to 07		May receive noise
Level: 01 to 02		Receives noise easily or disconnects
Level: 00		Out of range

Site Survey Preparation

1. Obtain a map and investigate the installation site.
 - a. Check the obstacles (e.g., shelves, columns, and partitions).
 - b. Check the materials of the structures (e.g., metal, concrete, and plywood).
 - c. Check the layout and dimensions of the room, corridor, etc.
 - d. Write down the above information on the map.
2. Examine the service area required by the user on the map, referring to the following example.
 - a. Draw the coverage area around a CS. Extend the coverage area 30 m to 60 m (98 ft to 197 ft) in each direction, depending on the materials of the building structures and obstacles in the installation site. Note that a CS cannot be installed outside a building.

- b. If 1 CS cannot cover the entire service area, install additional CSs as required. Overlap the coverage areas of adjacent CSs.

Where CS coverage areas overlap, the PS will start call handover to the next CS if the signal from one CS becomes weak. However, if a PS moves away from a CS and there are no CSs available for handover, the PS may go out of range and the call could be lost.

If the signal from the CS fades, due to the structure of the building, there may be some handover delay. The user will hear a range warning before handover in this case. This also applies in the case of interference from 2.4 GHz apparatus.

Example: Installing in a Room Separated by Interior Walls

Things to take note of:

- The room is separated by interior walls.
- The room is surrounded by concrete walls.

CS installation plan:

- The coverage area of each CS will not extend as far as when there are no obstacles, because the radio signals will be weakened by separating walls. Therefore, you will need 5 CSs to cover the entire room.

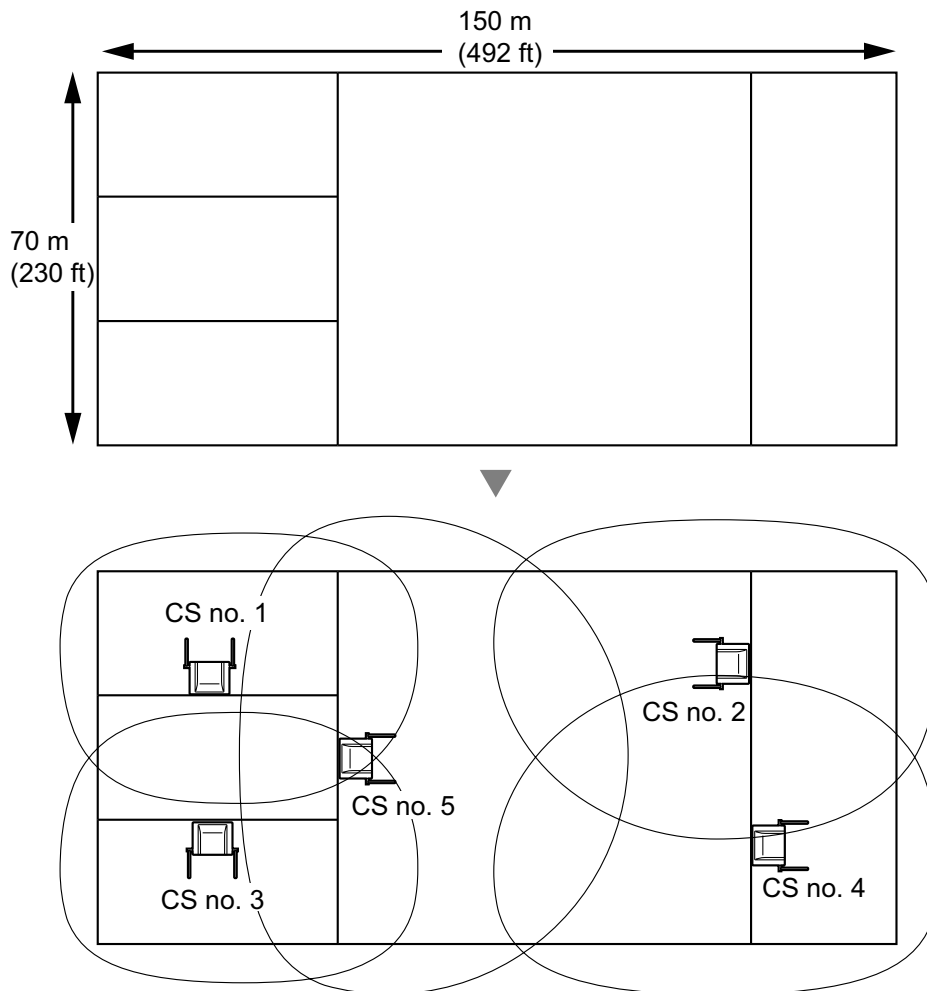

4 Before Site Survey

Setting and Installing the CS Temporarily for Site Survey

1. Switch the Radio Signal Test switch from OFF to ON.
2. Set the CS number switches as desired.
3. Set the Power Supply Select switch as desired (KX-T0151/KX-TDA0152 only).

KX-T0151/KX-TDA0152

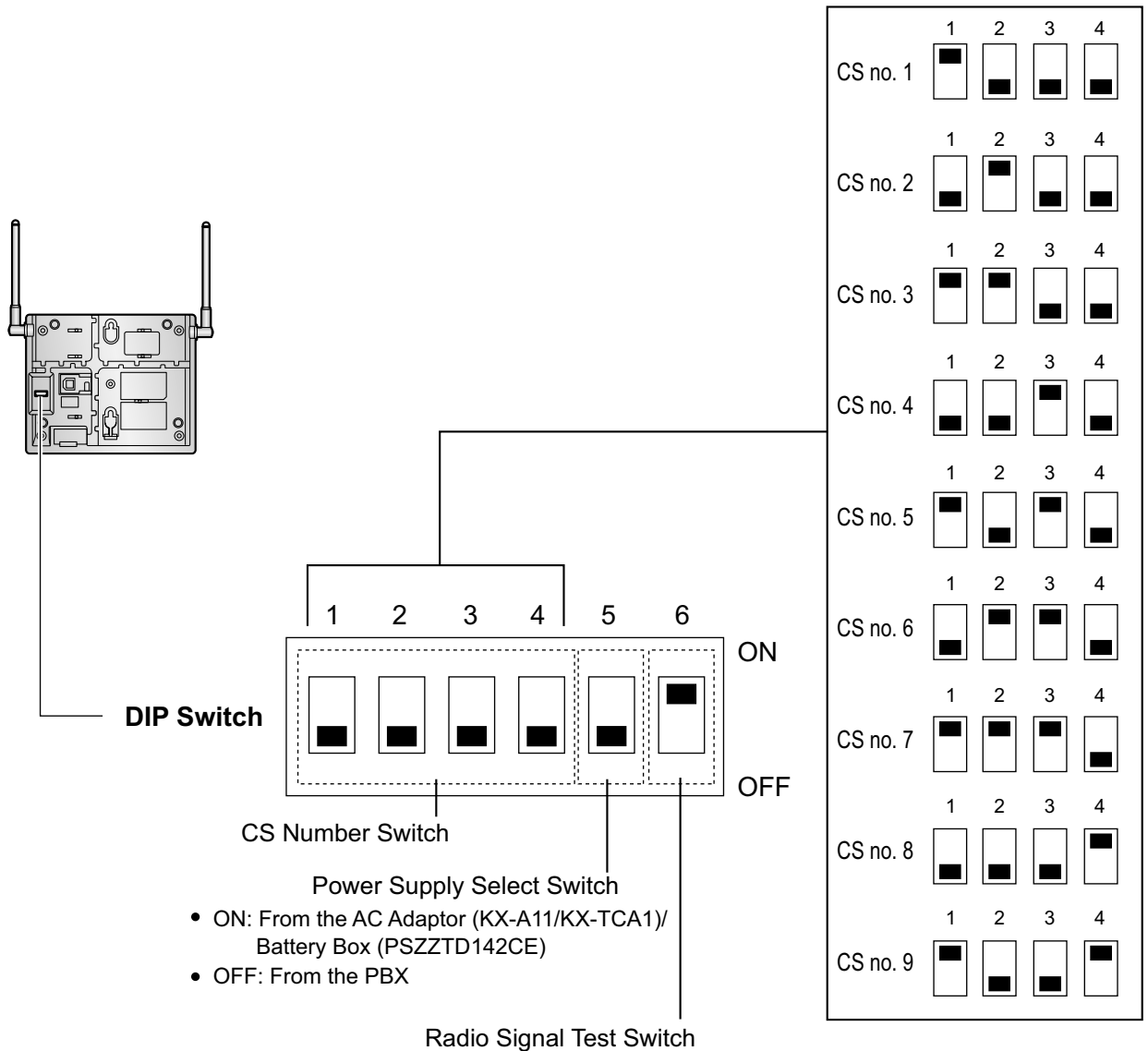

KX-T0141/KX-TDA0142

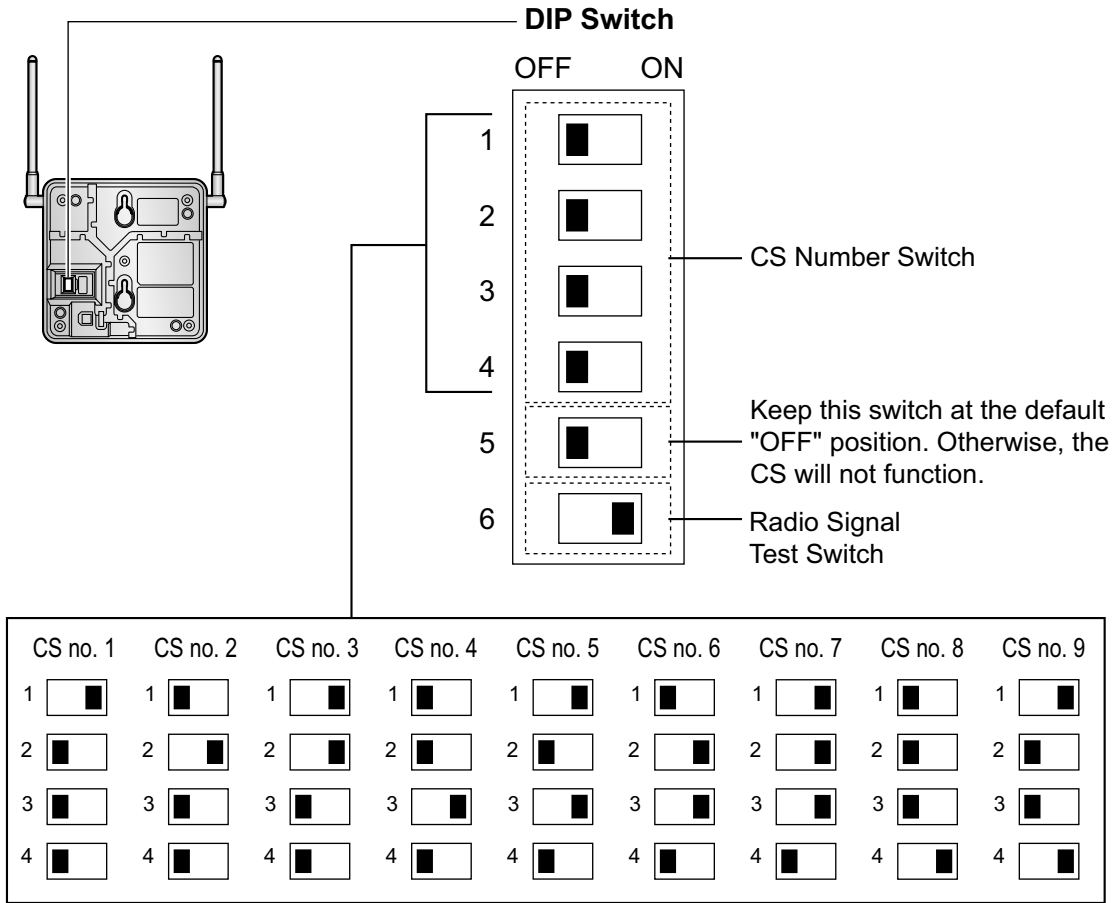

Note

If more than 1 CS is in Radio Signal Test mode, each CS must have a unique CS number.

- After setting the DIP switches, connect the CS to an AC adaptor/battery box using a power supply adaptor, or connect it to the PBX.

WARNING

When installing or testing a product with an external AC adaptor, the AC adaptor should be plugged into a wall outlet or floor-mounted AC outlet. Do not connect the AC adaptor to a ceiling-mounted AC outlet, as the weight of the adaptor may cause it to become disconnected.

Notice

If the Power Supply Select switch is set to ON in step 3, connect the CS to an AC adaptor/battery box. If it is set to OFF, connect the CS to the PBX (KX-T0151/KX-TDA0152 only).

KX-T0151/KX-TDA0152

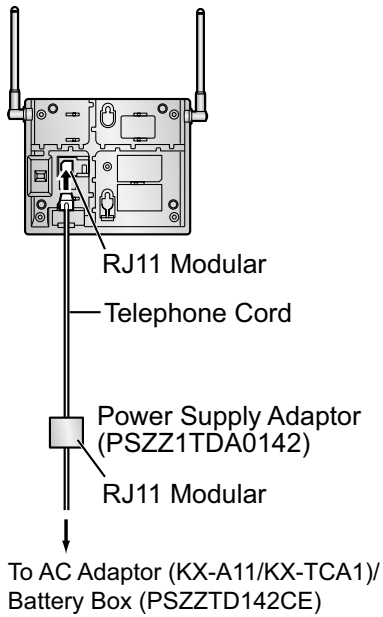

KX-T0141/KX-TDA0142

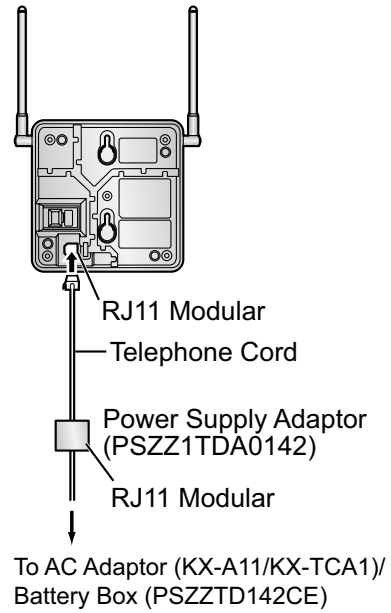

OR

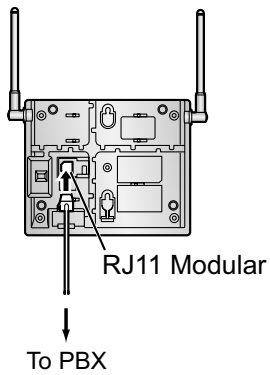

4 Before Site Survey

5. Install the CS temporarily for the site survey. Install the CS at least 2 m (6 ft 7 in) above the floor, and place the antennas so that they are pointing in directions that are 90 degrees apart (for antenna diversity), as follows:

Note

The illustration of the CS is based on the KX-T0151/KX-TDA0152.

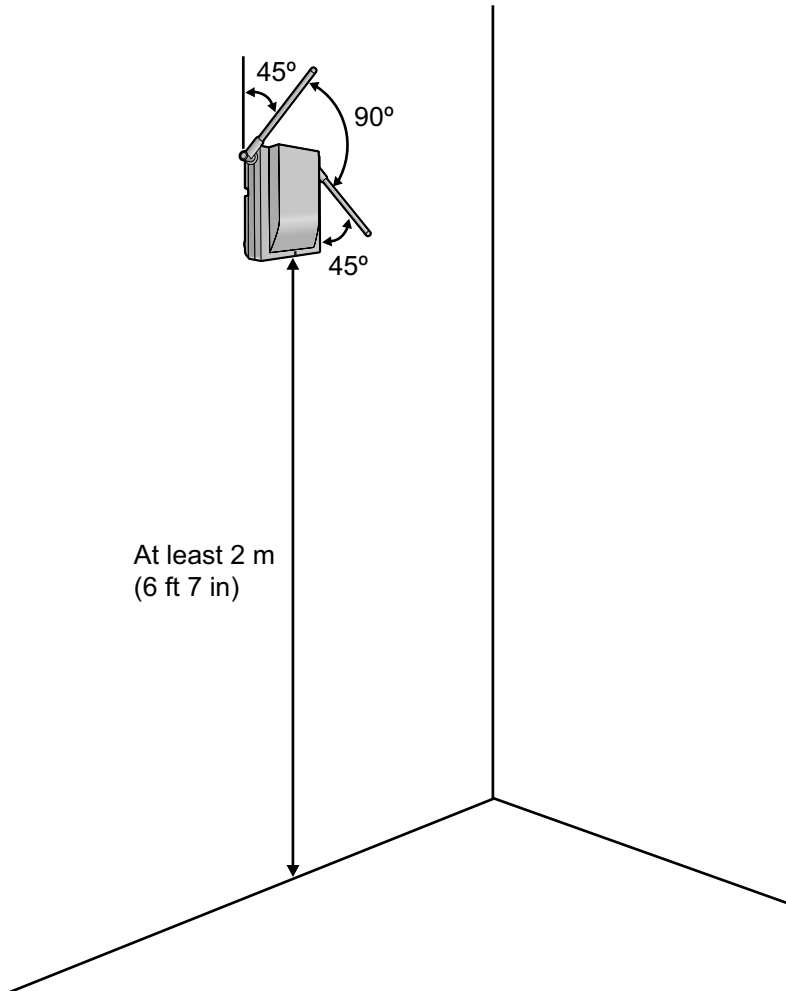

5 Site Survey

The PS has a Radio Signal Test mode that monitors the state of the radio link to the CS. After installing the CSs temporarily, set the PS to Radio Signal Test mode and measure each CS coverage area. Then, record the results on the map of the installation site.

Testing the Radio Signal Strength

Note

Display prompts for the site survey are only available in English.

1. Enter Radio Signal Test mode.

Using the KX-TD7684/KX-TD7694

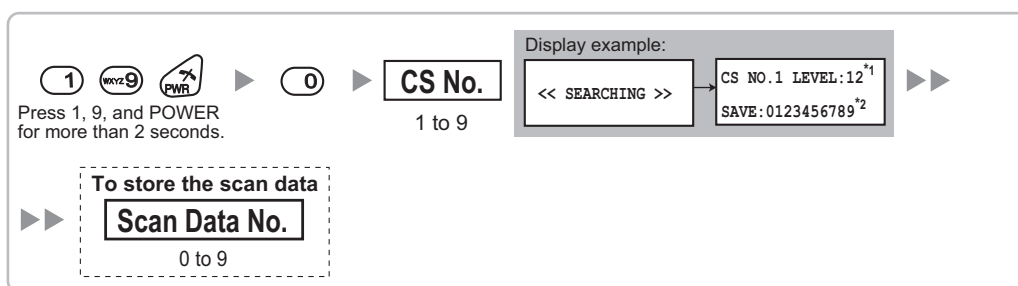

Using the KX-TD7680

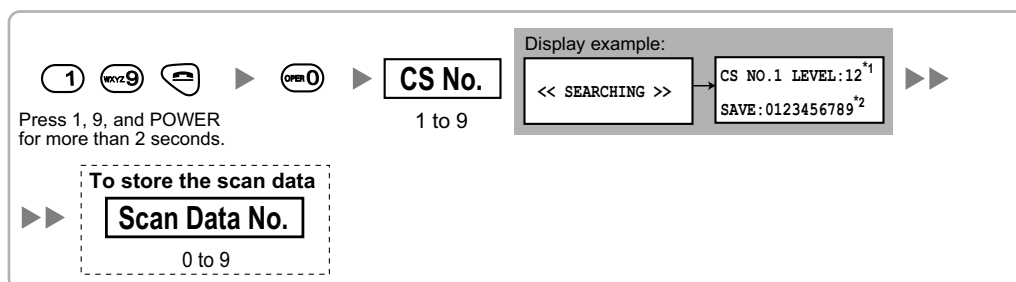

Using the KX-TD7690

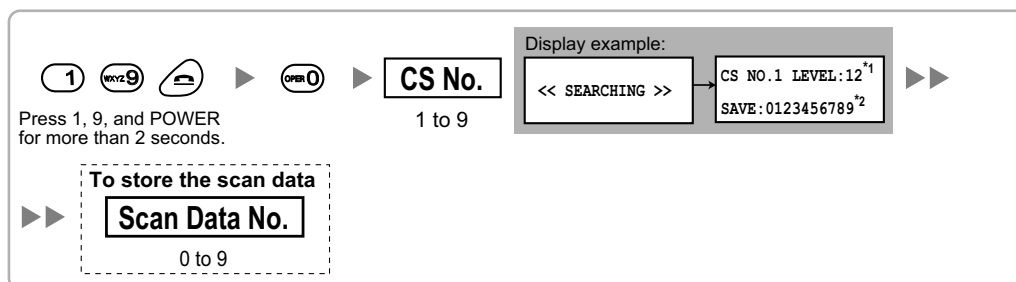

Note

*1: CS number and radio signal strength level.

*2: Scan data (test result) number. Empty memory space will be indicated by a number; stored memory space will be indicated by a "-".

2. Measure the radio signal strength by moving towards and away from the CS.
 - a. Move to the CS until the radio signal strength level becomes "12".
 - b. Move away from the CS and identify the CS coverage area within which the radio signal strength level is greater than "8". Draw the area on the map.
 - c. Move away from the CS and identify the CS coverage area within which the radio signal strength level is greater than "3". Draw the area on the map.

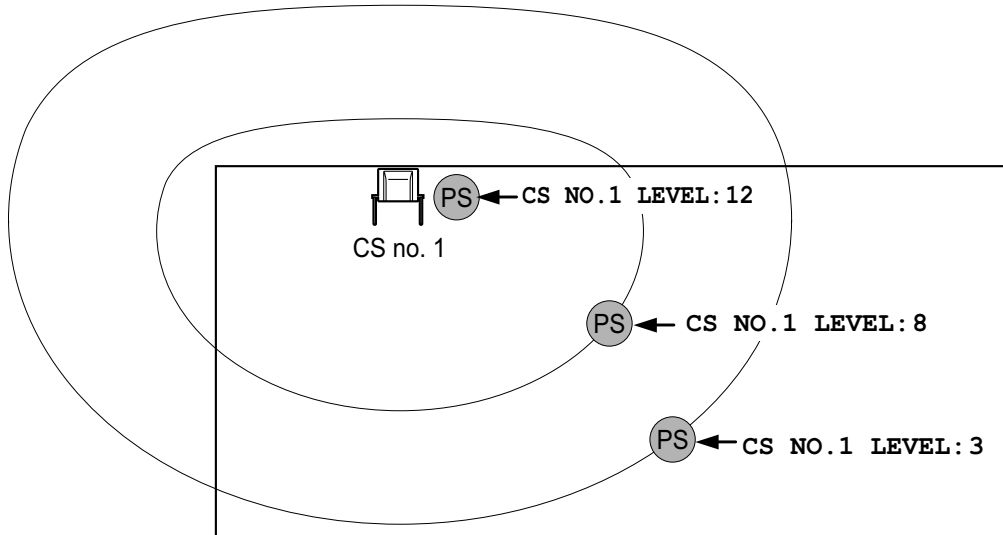

Radio Signal Strength Levels

Level: 11 to 12		Better
Level: 08 to 10		Good
Level: 03 to 07		May receive noise
Level: 01 to 02		Receives noise easily or disconnects
Level: 00		Out of range

3. Repeat steps 1 and 2 for other CSs, and relocate the CSs when necessary.
 - a. Overlap adjacent CS coverage areas where the radio signal strength level is "8" by 5 m to 10 m (16 ft to 33 ft).

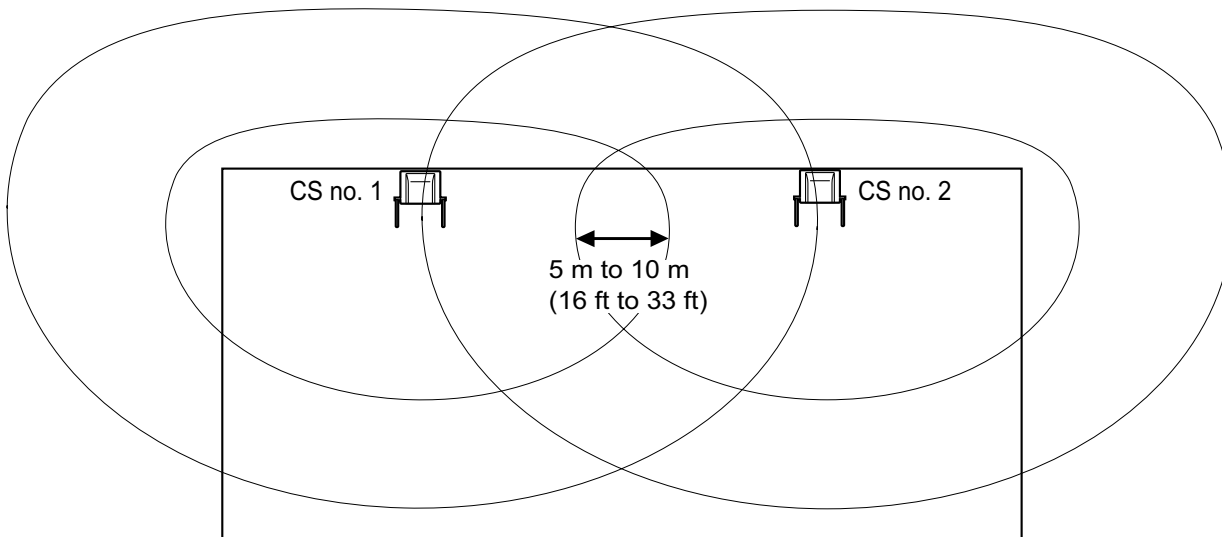

- b. Overlap the CS coverage areas of at least 2 CSs at any location in the installation site.

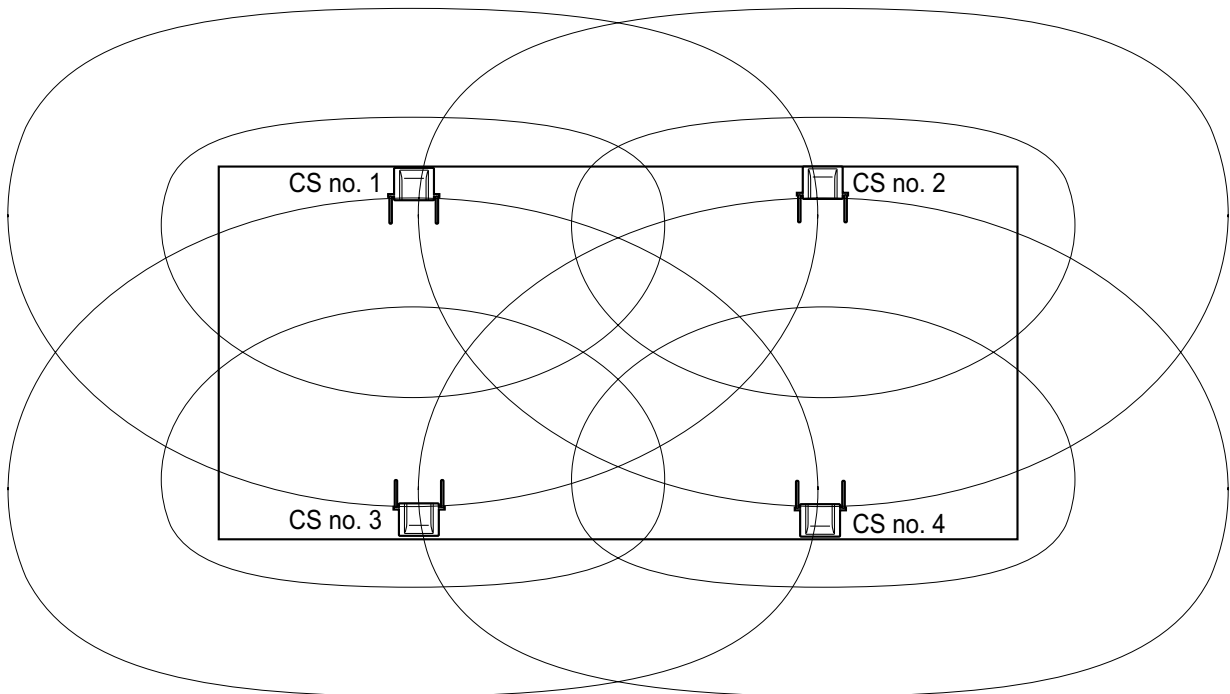

- c. Make sure that the radio signal strength level is greater than "3" at any location in the service area required by the user.

Referring to the Stored Scan Data

Using the KX-TD7684/KX-TD7694

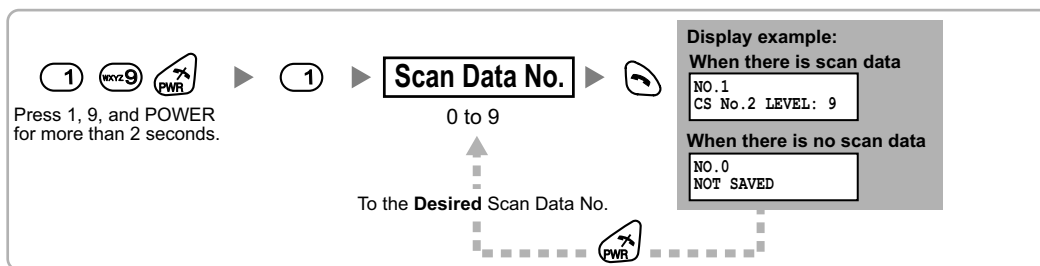

Using the KX-TD7680

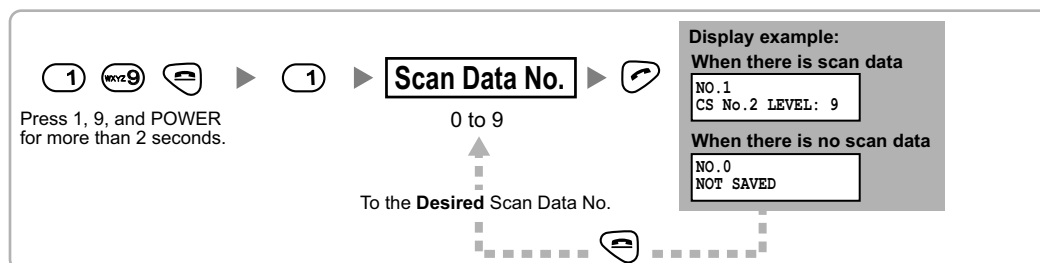

Using the KX-TD7690

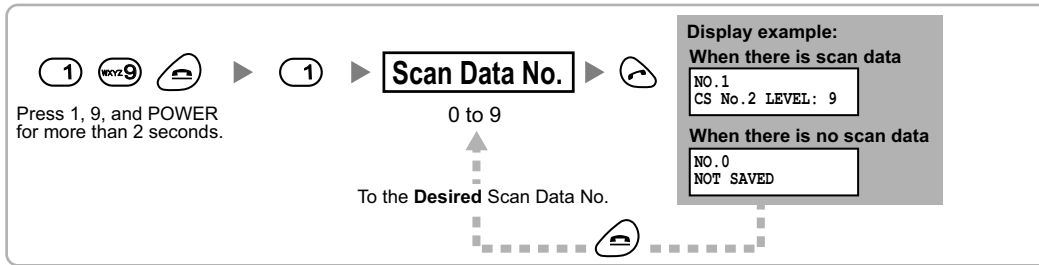

Deleting the Stored Scan Data

Using the KX-TD7684/KX-TD7694

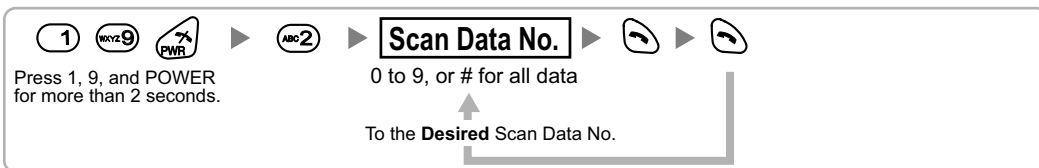

Using the KX-TD7680

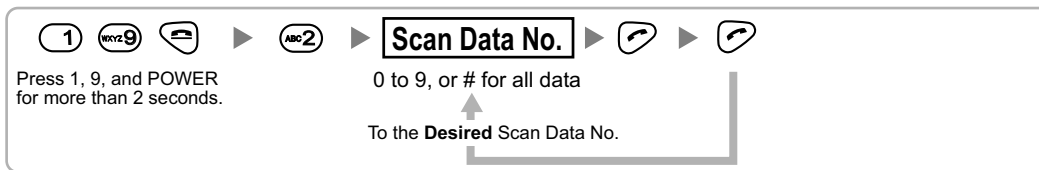

Using the KX-TD7690

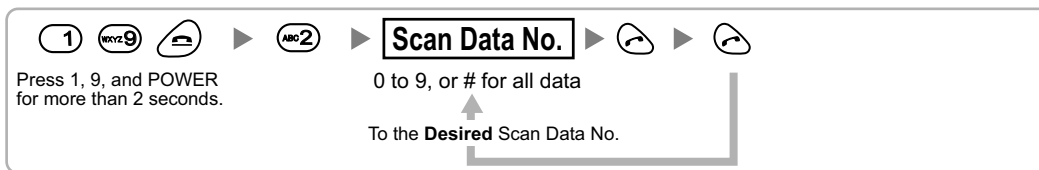

6 After Site Survey

After obtaining the proper measurement results, exit Radio Signal Test mode before connecting the CS to the PBX.

1. Hold down the POWER button on the PS until the PS is turned OFF.
2. Disconnect the CS from the AC adaptor/battery box or the PBX to stop supplying electricity.

KX-T0151/KX-TDA0152

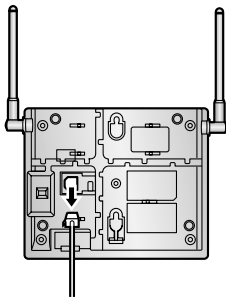

KX-T0141/KX-TDA0142

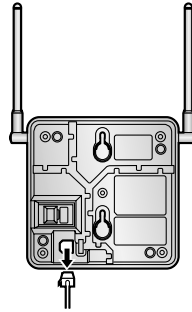

3. Switch all DIP switches on the CS from ON to OFF.

KX-T0151/KX-TDA0152

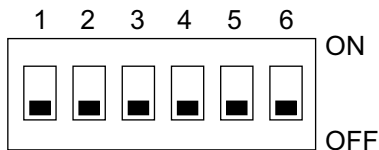

KX-T0141/KX-TDA0142

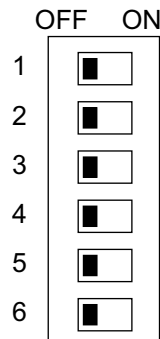

7 Connecting a Cell Station to the PBX

Connection Example for KX-TAW848/KX-TDA50

Refer to the following example to connect a CS to the PBX.

KX-T0151/KX-T0141 connecting to KX-TAW848/KX-TDA50

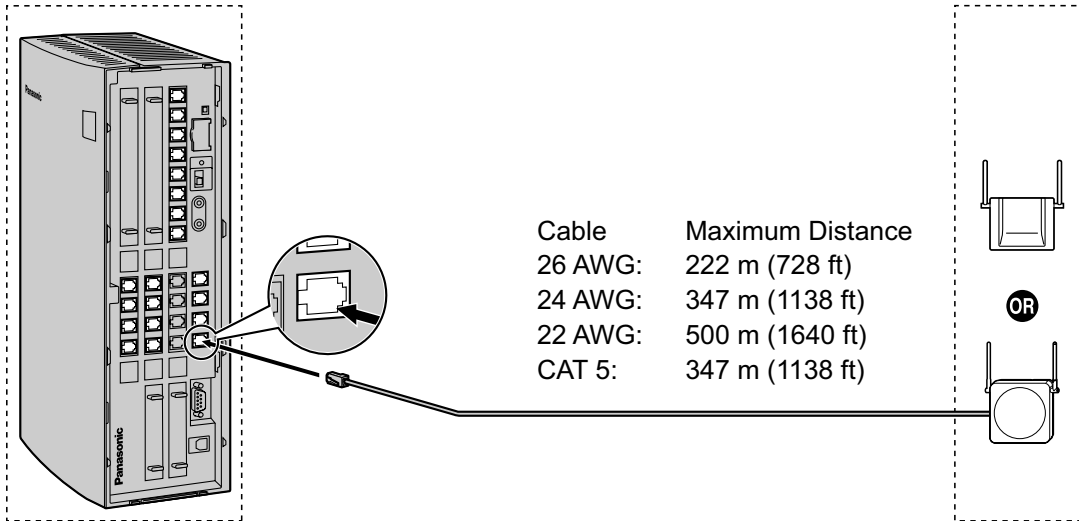

A Super Hybrid Port (Hybrid Port),
or HLC4/DLC4/DLC8 card (RJ11)

CS (RJ11)

Signal Name	Pin No.	Pin No.	Signal Name
D1	1	1	D1
	2	2	
	3	3	
D2	4	4	D2

Accessories and User-supplied Items for the CS

Accessories (included): Screws × 2, Washers × 2

User-supplied (not included): RJ11 connector

Note

For details about the Super Hybrid Ports (Hybrid Ports) or HLC4/DLC4/DLC8 card, refer to the Installation Manual for your PBX.

Connection Examples for KX-TDA100/KX-TDA200/KX-TDA600/KX-TDE100/ KX-TDE200/KX-TDE600

Refer to the following examples to connect a CS to the PBX.

KX-TDA0152/KX-TDA0142 connecting to KX-TDA100/KX-TDA200/KX-TDA600/KX-TDE100/ KX-TDE200/KX-TDE600

Note

The illustration of the PBX is based on the KX-TDE200.

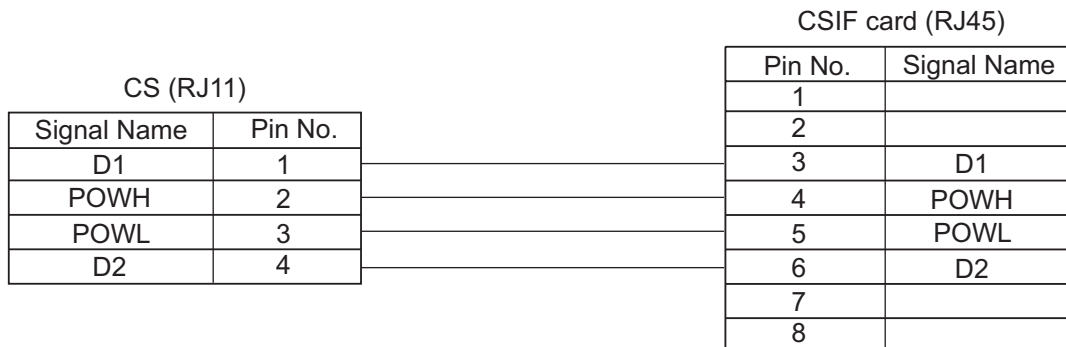
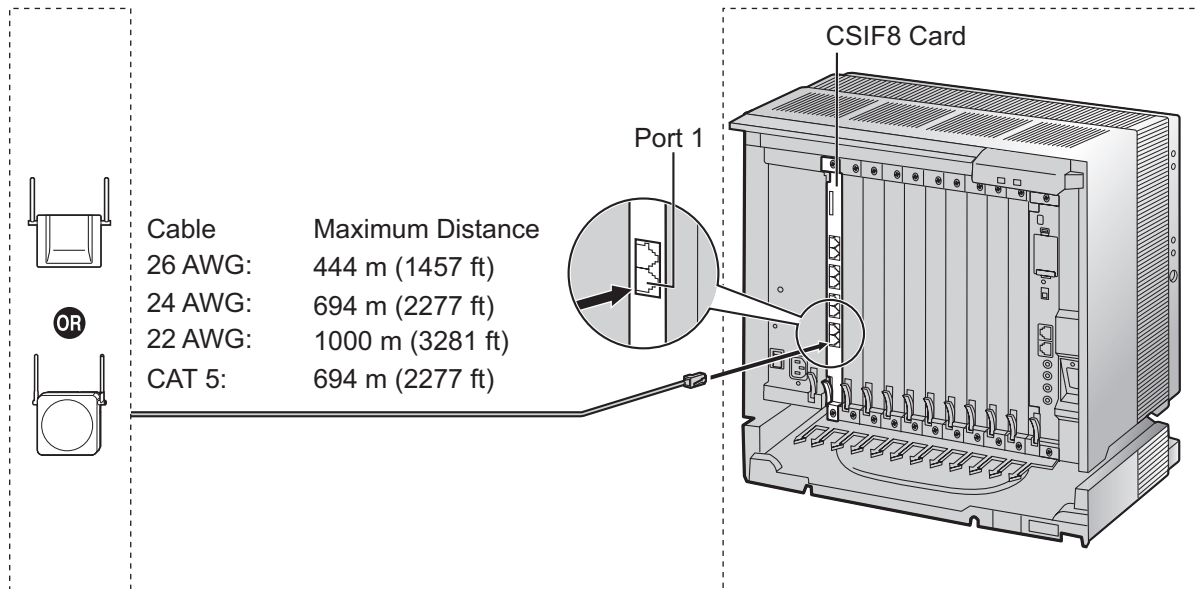

Accessories and User-supplied Items for the CS

Accessories (included): Screws × 2, Washers × 2

User-supplied (not included): RJ11 connector

Note

For details about the CSIF card, refer to the Installation Manual for your PBX.

**KX-T0151/KX-T0141 connecting to KX-TDA100/KX-TDA200/KX-TDA600/KX-TDE100/
KX-TDE200/KX-TDE600**

Note

The illustration of the PBX is based on the KX-TDE200.

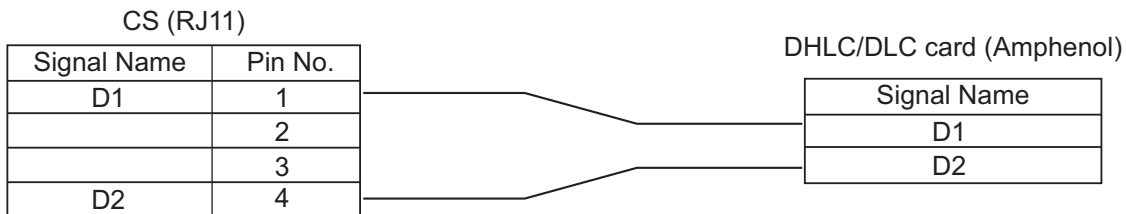
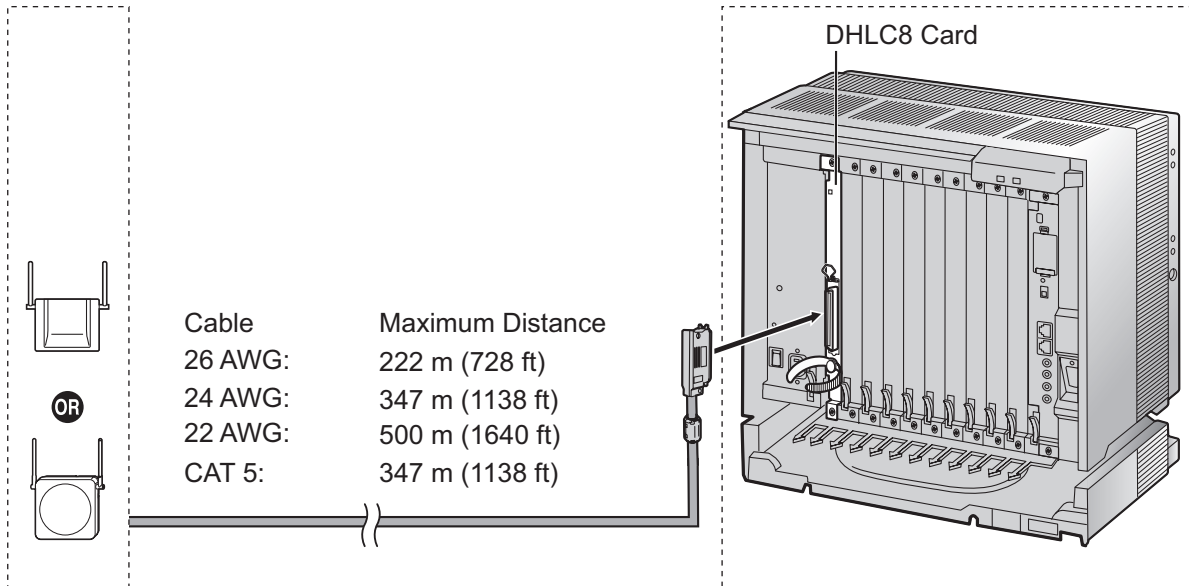

Accessories and User-supplied Items for the CS

Accessories (included): Screws × 2, Washers × 2

User-supplied (not included): RJ11 connector

Note

For details about DHLC/DLC card, refer to the Installation Manual for your PBX.

Connection Example for KX-NCP500/KX-NCP1000

Refer to the following example to connect a CS to the PBX.

KX-T0151/KX-T0141 connecting to KX-NCP500/KX-NCP1000

Note

The illustration of the PBX is based on the KX-NCP500.

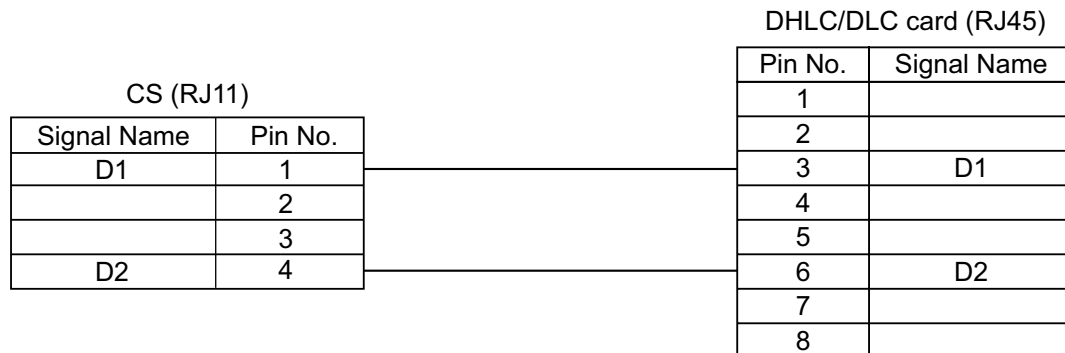
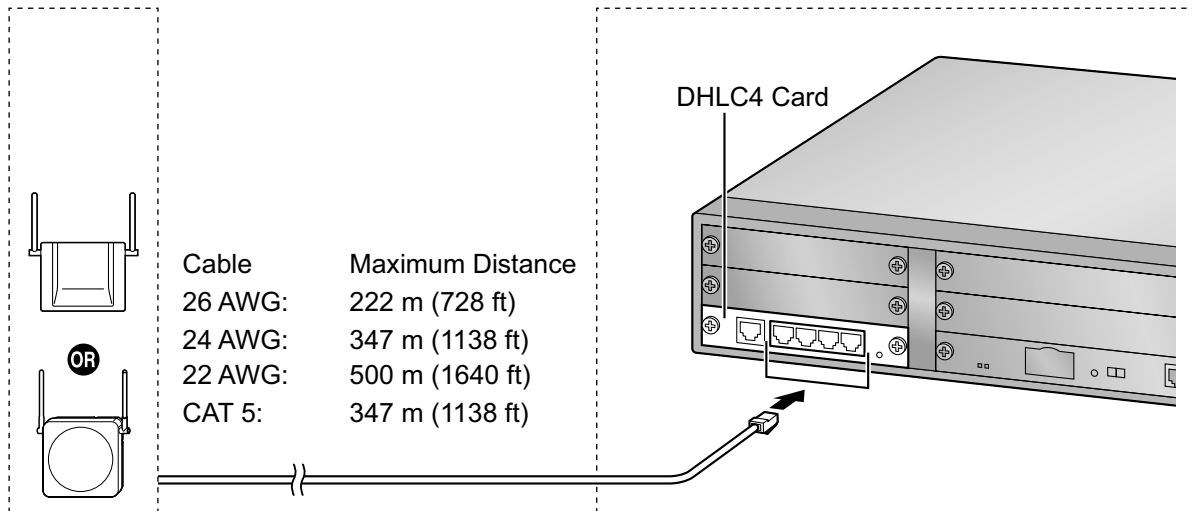

Accessories and User-supplied Items for the CS

Accessories (included): Screws × 2, Washers × 2

User-supplied (not included): RJ11 connector

Note

For details about the DHLC/DLC card, refer to the Installation Manual for your PBX.

Connecting the CS

1. Connect the cable from the PBX to the CS.

KX-T0151/KX-TDA0152

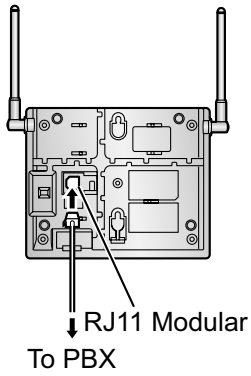

KX-T0141/KX-TDA0142

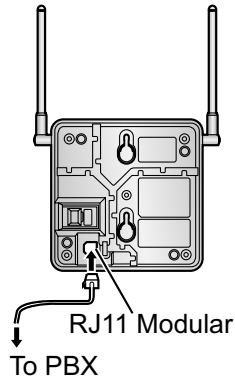

2. Pass the cable through the groove of the CS (in any direction depending on your preference).

KX-T0151/KX-TDA0152

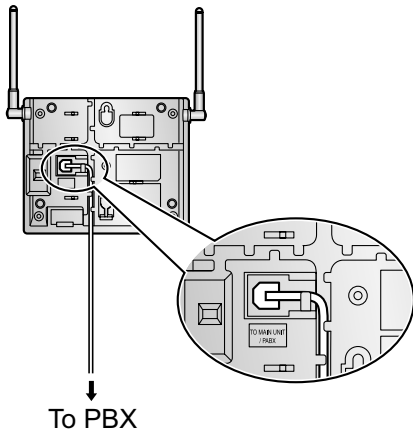

KX-T0141/KX-TDA0142

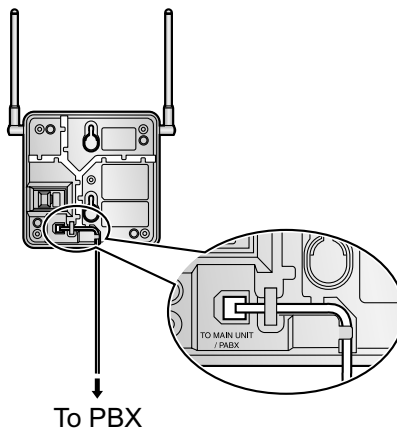

Registering the PS

The PS must be registered to the PBX before it can be used. Programming of both the PS and PBX is required. A Proprietary Telephone (PT) with multiline display (e.g., KX-T7636 6-line display) is required to perform the PBX system programming.

Note

For details about system programming using a PT, refer to "PT Programming" in the Feature Manual, and "PT Programming" in the PT Programming Manual for your PBX.

Entering the System Programming Mode PT (Administrator Level)



PS (Using the KX-TD7684/KX-TD7694)

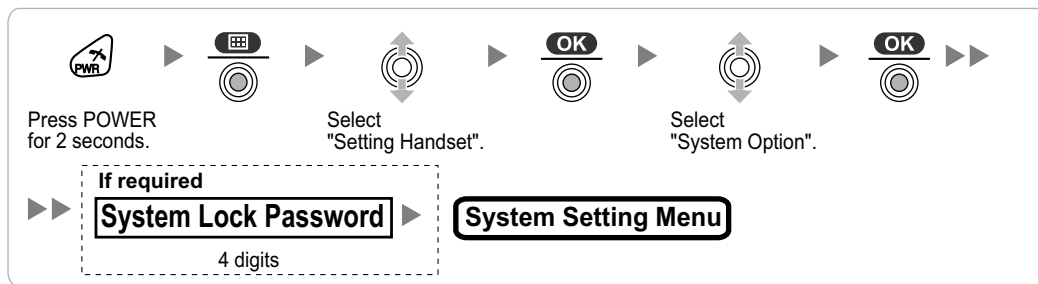

PS (Using the KX-TD7680)

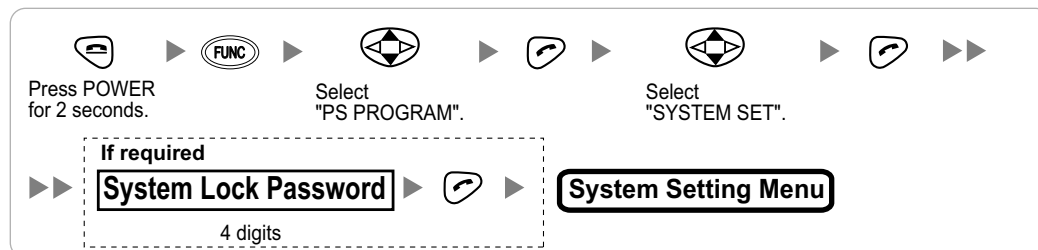

PS (Using the KX-TD7690)

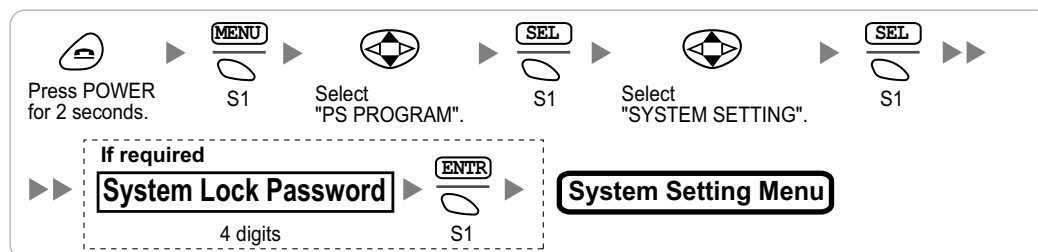

Note

◆ means default value throughout this section.

Setting the Personal Identification Number (PIN) for PS Registration

To prevent registering the PS to a wrong PBX, a PIN for PS registration can be set to the PBX. Before registering the PS to the PBX, enter the PIN set to the PBX into the PS. By doing so, the PS will only be registered to the PBX with the matching PIN.

CAUTION

To avoid unauthorized access and possible abuse of the PBX, we strongly recommend:

- a. Keeping the password (PIN for PS registration) secret.
- b. Not using the default password and changing the password regularly.
- c. Selecting a complex, random password that cannot be easily guessed.

Note

The PIN for PS registration will only be used when registering the PS to the PBX. Therefore, during normal operation after registration, even if there is more than 1 PBX with the same PIN near the PS, the PS will not be inadvertently linked to a different PBX.

Setting the PIN for PBX

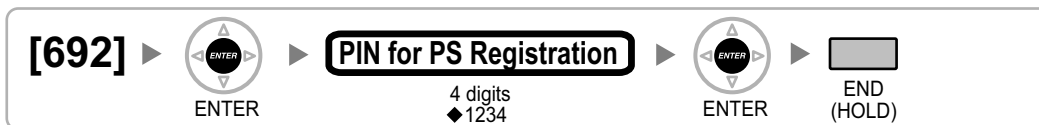

Setting the PIN for PS

Using the KX-TD7684/KX-TD7694

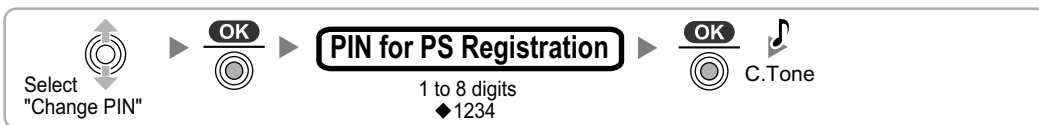

Using the KX-TD7680

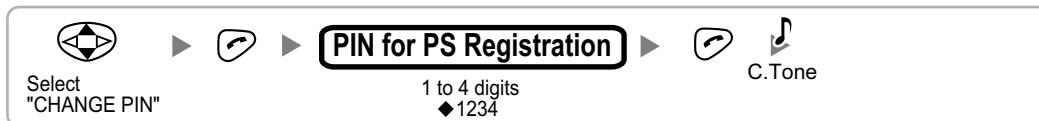

Using the KX-TD7690

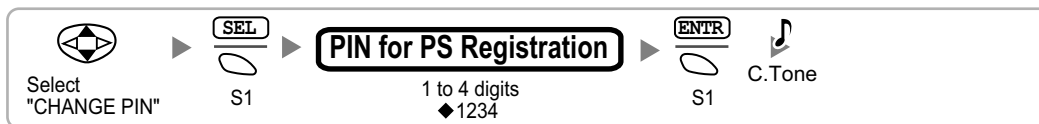

PS Registration

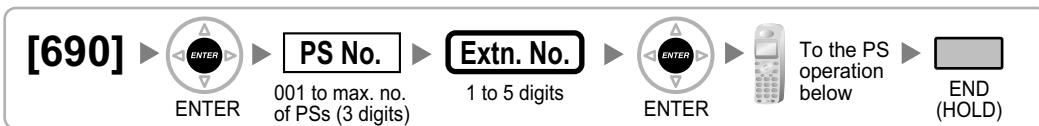

When the PS has not been registered yet

When registering the PS for the first time, it is possible to select the desired language for the display. (You do not need to enter the PS system programming mode when registering for the first time.)

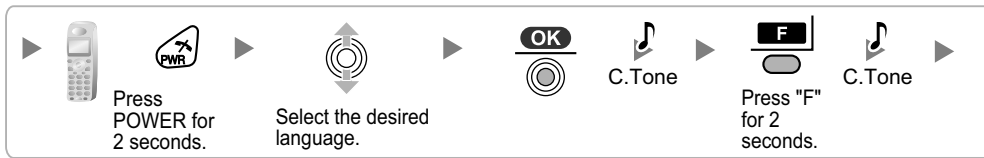
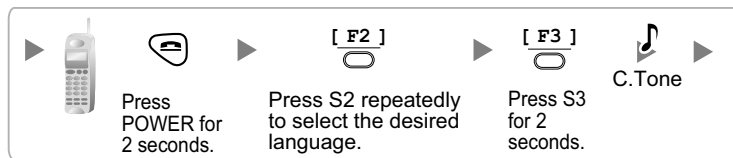
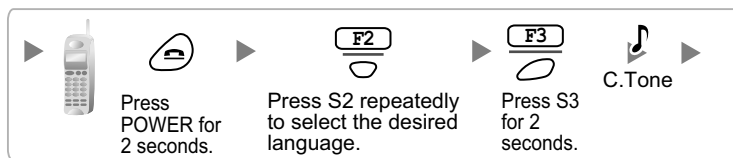
Using the KX-TD7684/KX-TD7694**Using the KX-TD7680****Using the KX-TD7690****When the PS has already been registered to another PBX**

One PS can be registered to a maximum of 4 different PBXs.

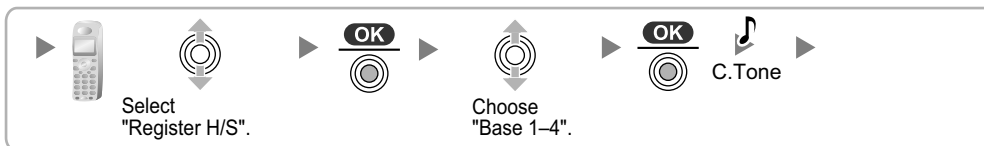
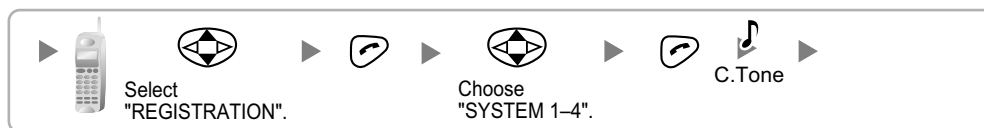
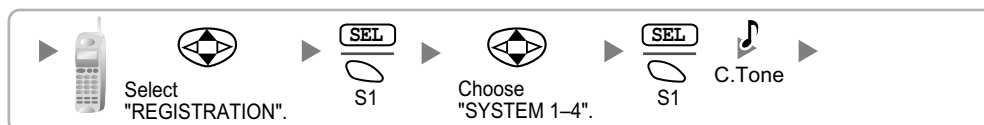
Using the KX-TD7684/KX-TD7694**Using the KX-TD7680****Using the KX-TD7690****Setting the System Lock**

After PS registration, it is possible to set a 4-digit system lock password to prevent unauthorized access to PS system settings. When system lock is enabled, the system lock password will be required to access PS system settings.

CAUTION

To avoid unauthorized access and possible abuse of the PBX, we strongly recommend:

- a. Keeping the password secret.
- b. Changing your password regularly.
- c. Selecting a complex, random password that cannot be easily guessed.

Using the KX-TD7684/KX-TD7694

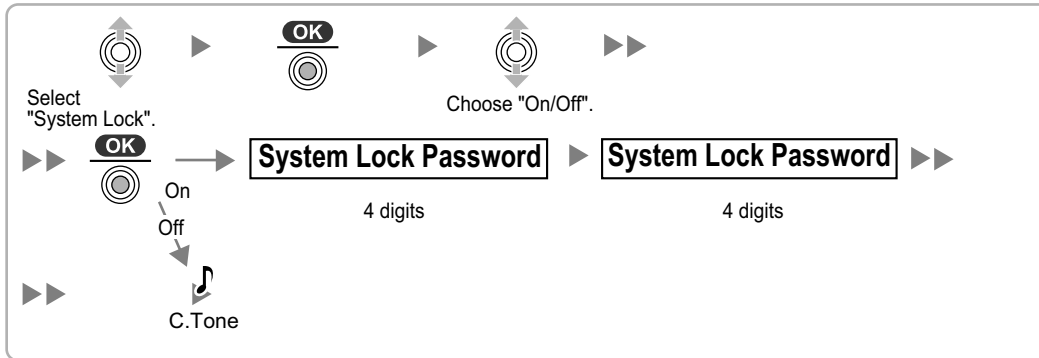

Using the KX-TD7680

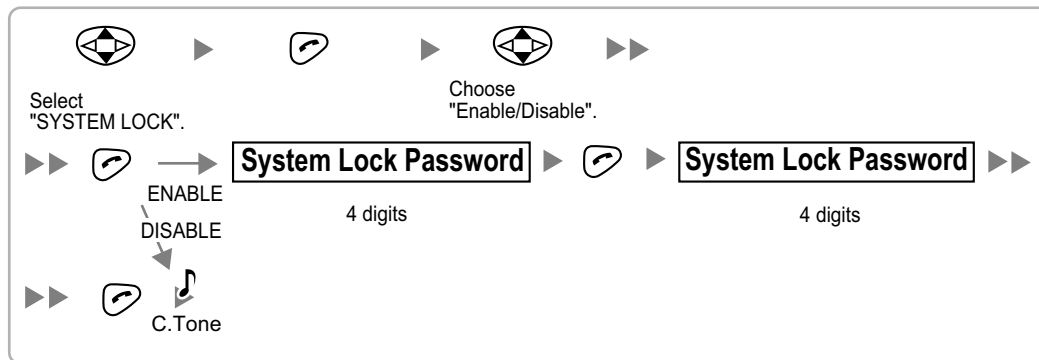

Using the KX-TD7690

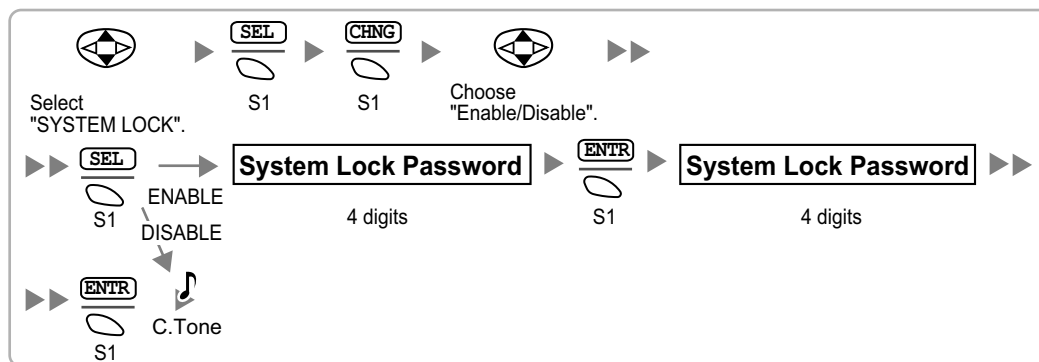

PS Termination

Confirm the following before canceling the PS registration:

- The PS is turned on.

- The PS is within range.

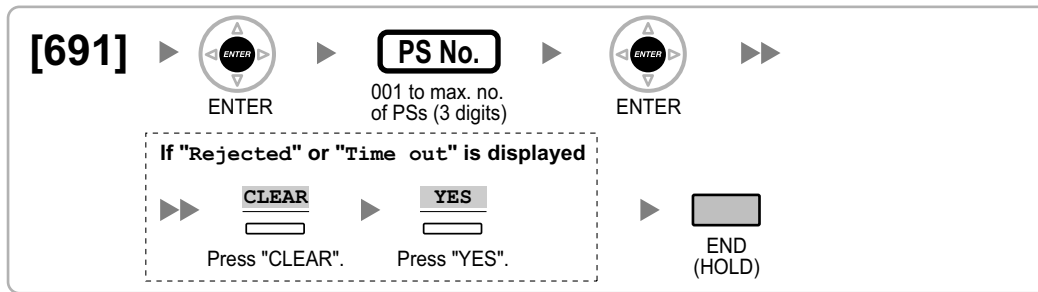

If "Rejected" or "Time out" is displayed

The registration information is still stored in the PS. You need to delete the registration information from the PS.

Using the KX-TD7684/KX-TD7694

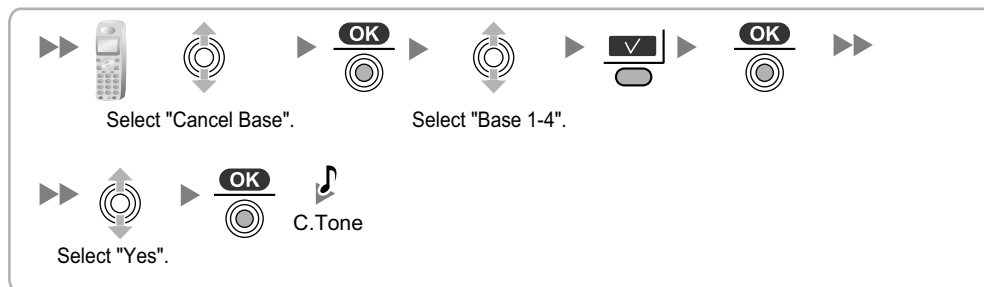

Using the KX-TD7680

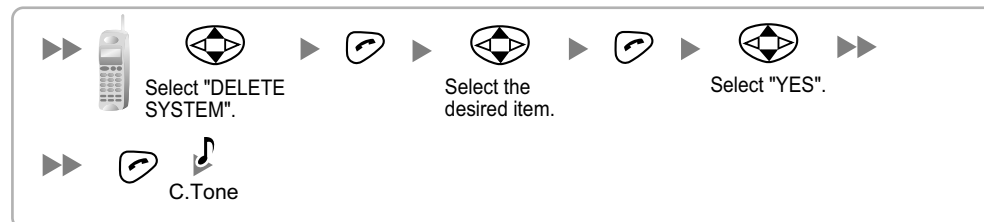

Using the KX-TD7690

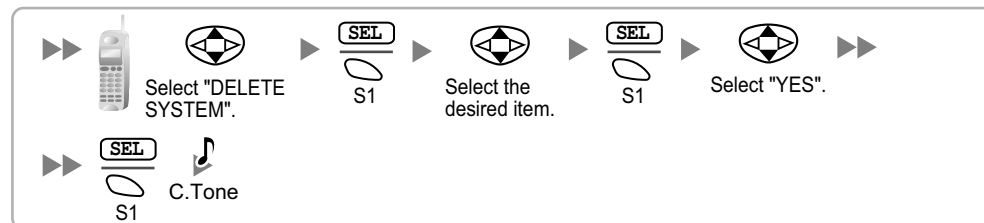

Testing the Operation

Walk around the service area while having a conversation using a registered PS. If noise is frequent or conversations disconnect, relocate the CSs or install an additional CS.

8 Wall Mounting

Mounting the KX-T0151/KX-TDA0152

WARNING

- Make sure that the wall that the unit will be attached to is strong enough to support the unit (approx. 310 g [11 oz]). If not, it is necessary for the wall to be reinforced.
- Only use the wall-mounting equipment (screws, washers, wall mounting plate) included with the unit.
- When this product is no longer in use, make sure to detach it from the wall.

CAUTION

- When driving the screws into the wall, be careful to avoid touching any metal laths, wire laths or metal plates in the wall.
 - Do not stretch or bend the cables. Also, do not allow anything to rest on the cables.
 - Use cables that are fire-resistant or fireproof.
 - The CS and the cables should never be placed near or over a radiator or other heat source.
 - Do not bundle cables that are connected to the CS with the AC power cords of machines located nearby.
 - Make sure the cables are securely fastened to the wall.
1. Place the reference for wall mounting (KX-T0151/KX-TDA0152) on the wall to mark the 2 screw positions.
 2. Install the 2 screws and washers (included) into the wall.

Note

- Make sure that the screw heads are at the same distance from the wall.
 - Install the screws perpendicular to the wall.
3. Insert the upper and lower tabs of the wall mounting plate into the designated openings in the base unit.

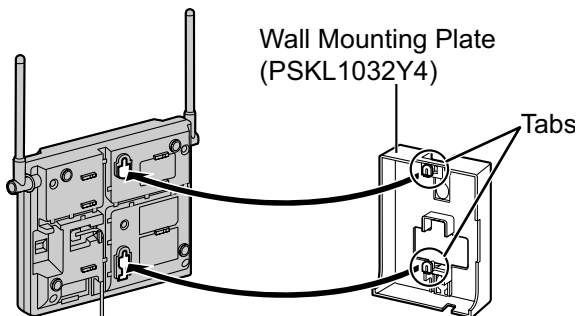

- Slide the wall mounting plate in the direction of the arrow until it clicks.

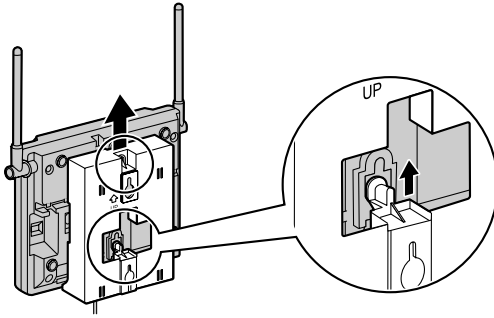

- Hook the CS on the screw heads.

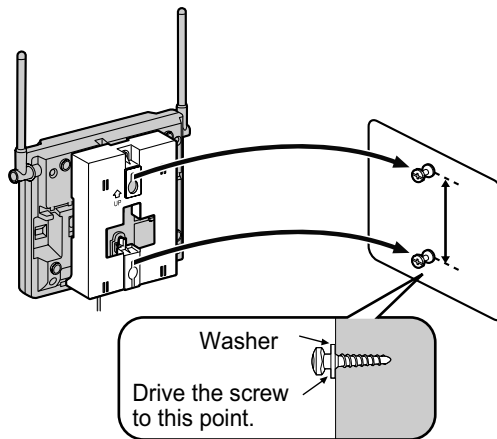

- Place the antennas so that they are pointing in directions that are 90 degrees apart (for antenna diversity), as follows:

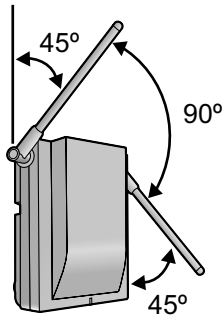

Reference for Wall Mounting (KX-T0151/KX-TDA0152)

Please copy this page and use as a reference for wall mounting.

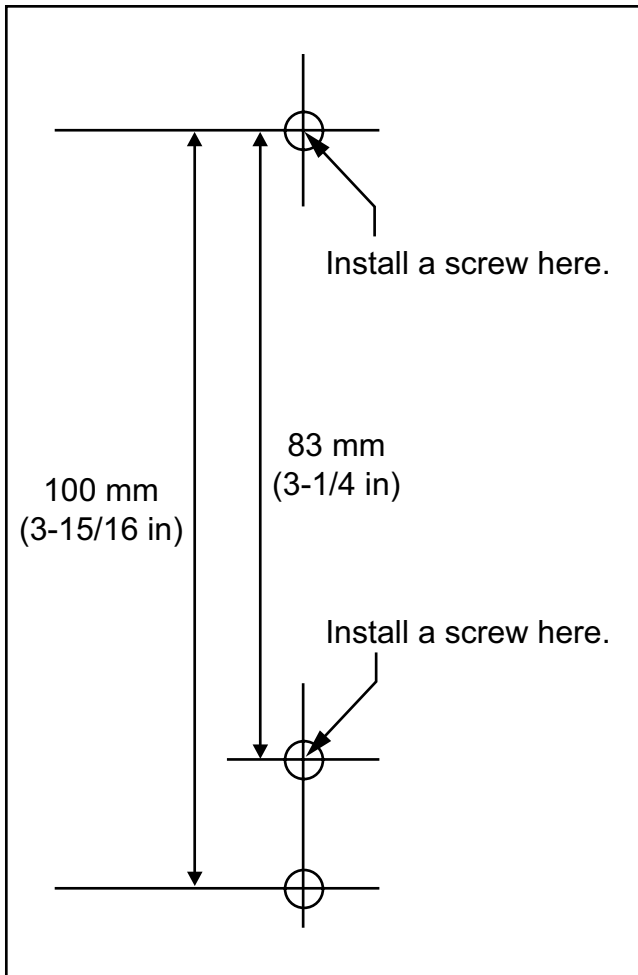

Note

Make sure to set the print size to correspond with the size of this page. If the dimension of the paper output still deviates slightly from the measurement indicated here, use the measurement indicated here.

Mounting the KX-T0141/KX-TDA0142

WARNING

- Make sure that the wall that the unit will be attached to is strong enough to support the unit (approx. 310 g [11 oz]). If not, it is necessary for the wall to be reinforced.
- Only use the wall-mounting equipment (screws, washers) included with the unit.
- When this product is no longer in use, make sure to detach it from the wall.

CAUTION

- When driving the screws into the wall, be careful to avoid touching any metal laths, wire laths or metal plates in the wall.
 - Do not stretch or bend the cables. Also, do not allow anything to rest on the cables.
 - Use cables that are fire-resistant or fireproof.
 - The CS and the cables should never be placed near or over a radiator or other heat source.
 - Do not bundle cables that are connected to the CS with the AC power cords of machines located nearby.
 - Make sure the cables are securely fastened to the wall.
1. Place the reference for wall mounting (KX-T0141/KX-TDA0142) on the wall to mark the 2 screw positions.
 2. Install the 2 screws and washers (included) into the wall.

Note

- Make sure that the screw heads are at the same distance from the wall.
 - Install the screws perpendicular to the wall.
3. Hook the CS on the screw heads.

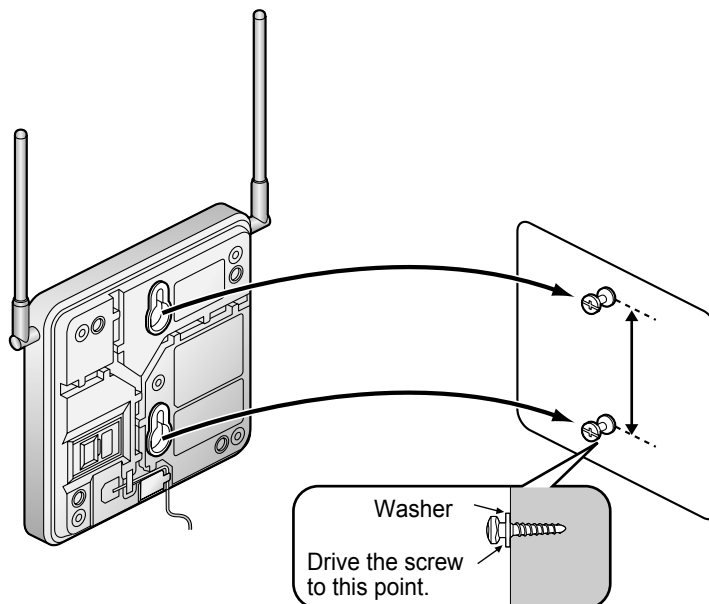

8 Wall Mounting

- Place the antennas so that they are pointing in directions that are 90 degrees apart (for antenna diversity), as follows:

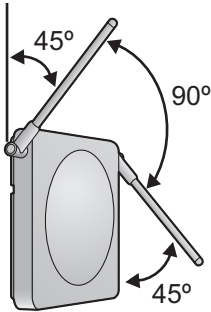

Reference for Wall Mounting (KX-T0141/KX-TDA0142)

Please copy this page and use as a reference for wall mounting.

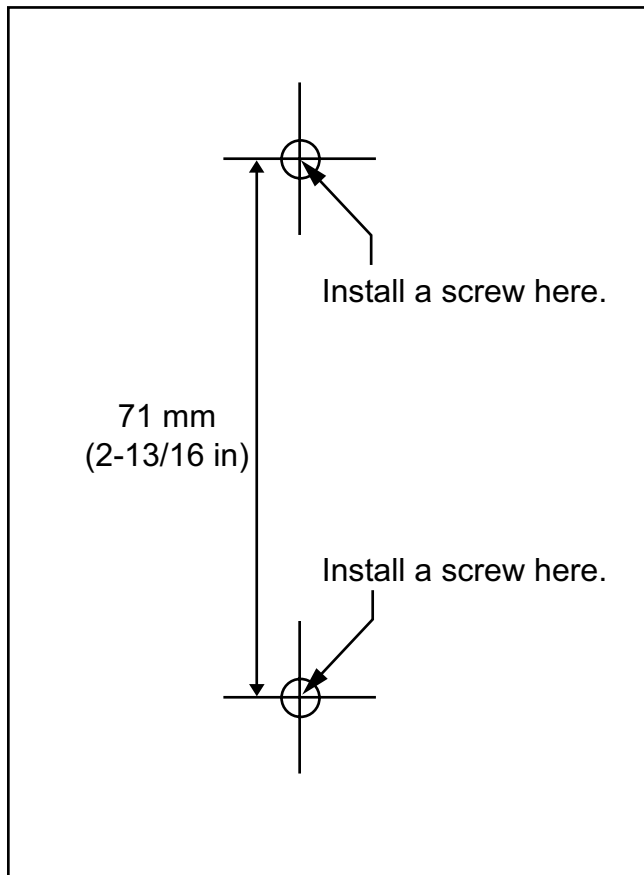

Note

Make sure to set the print size to correspond with the size of this page. If the dimension of the paper output still deviates slightly from the measurement indicated here, use the measurement indicated here.

9 Troubleshooting

PROBLEM	PROBABLE CAUSE	SOLUTION
<ul style="list-style-type: none"> The LED of the CS does not change to Green ON. 	<ul style="list-style-type: none"> The optional service card is not working. 	<ul style="list-style-type: none"> Install the card properly.
	<ul style="list-style-type: none"> CS is not connected properly. 	<ul style="list-style-type: none"> Make sure that the cable is connected properly with correct pin assignments. Also, make sure that the cable does not make short circuits.
	<ul style="list-style-type: none"> CS is not set for normal operation. 	<ul style="list-style-type: none"> Switch all DIP switches off.
	<ul style="list-style-type: none"> The status of the port that the CS is connected to is Out of Service. 	<ul style="list-style-type: none"> Change the port status from Out of Service to In Service using the Maintenance Console.
<ul style="list-style-type: none"> The LED of the CS stays Red ON during normal operation. 	<ul style="list-style-type: none"> CS malfunction 	<ul style="list-style-type: none"> Replace the CS.
<ul style="list-style-type: none"> Cannot register the PS. 	<ul style="list-style-type: none"> Wrong Personal Identification Number (PIN) is registered to the PS. 	<ul style="list-style-type: none"> Enter the PIN set to the PBX into the PS.
<ul style="list-style-type: none"> PS becomes out of range. Cannot make calls using the PS. 	<ul style="list-style-type: none"> Location of CS is not good. Access system of the PS is not properly set. 	<ul style="list-style-type: none"> Locate the CS properly (refer to "5 Site Survey"). Change the access system setting of the PS to the appropriate system or automatic.
<ul style="list-style-type: none"> Noise is frequent while using the PS. Conversations disconnect while using the PS. "NO SERVICE" is displayed on the PS's screen. 	<ul style="list-style-type: none"> Call handover is not working. PS is out of CS coverage area. 	<ul style="list-style-type: none"> Locate the CS properly (refer to "5 Site Survey").
<ul style="list-style-type: none"> The CS is not busy (i.e., the status of the LED is not Moderate Green Flashing), but calls cannot be made or received. There is noise during a phone call. 	<ul style="list-style-type: none"> CSs are located too close together in the same area. 	<ul style="list-style-type: none"> Reduce the number of CSs in the area, or increase the distance between CSs (refer to "5 Site Survey").
<ul style="list-style-type: none"> PS stays out of service when the CS status is changed from Out of Service to In Service. 	<ul style="list-style-type: none"> It may take about 20 s for the CS to start up after the status has been changed to In Service. 	<ul style="list-style-type: none"> Wait until the CS starts up.



See More
Panasonic Manuals



www.voicesonic.com
Phone: 877.289.2829

Panasonic Corporation of North America
One Panasonic Way, Secaucus, New Jersey 07094

<http://www.panasonic.com/csd>

Copyright:

This material is copyrighted by Panasonic System Networks Co., Ltd., and may be reproduced for internal use only. All other reproduction, in whole or in part, is prohibited without the written consent of Panasonic System Networks Co., Ltd.

© Panasonic System Networks Co., Ltd. 2009