

Cummins **Onan**



Installation Manual

RV Generator Set

HDZAA (Spec A–D)

California

Proposition 65 Warning

Diesel engine exhaust and some of its constituents are known to the State of California to cause cancer, birth defects, and other reproductive harm.



WARNING



**Do not use this genset on a boat
Such use may violate U. S. Coast Guard
regulations and can result in
severe personal injury or death from
fire, electrocution, or
carbon monoxide poisoning**

Table of Contents

SECTION	PAGE
SAFETY PRECAUTIONS	iii
1. INTRODUCTION	1-1
About this Manual	1-1
Outline Drawings	1-1
Installation Codes and Standards for Safety	1-1
2. LOCATION, MOUNTING, AND VENTILATION	2-1
Location	2-1
Mounting	2-2
Ventilation	2-4
3. EXHAUST CONNECTIONS	3-1
Muffler	3-1
Tailpipe	3-2
4. FUEL CONNECTIONS	4-1
5. ELECTRICAL CONNECTIONS	5-1
AC Power Output	5-1
Remote Operator Panel	5-3
6. INSTALLATION REVIEW AND STARTUP	6-1
Installation Review and Startup	6-1
Hot Air Recirculation Test	6-2
7. SPECIFICATIONS	7-1
Load on engine	7-1
OUTLINE DRAWING—SHEET 1 OF 2	A-1
OUTLINE DRAWING—SHEET 2 OF 2	A-2



THIS PAGE IS INTENDED TO BE BLANK



SAFETY PRECAUTIONS

Thoroughly read the **OPERATOR'S MANUAL** before operating the generator set. Safe operation and top performance can only be obtained when equipment is properly operated and maintained.

The following symbols in this manual alert you to potential hazards to the operator, service person and equipment.

⚠ DANGER alerts you to an immediate hazard that will result in severe personal injury or death.

⚠ WARNING alerts you to a hazard or unsafe practice that can result in severe personal injury or death.

⚠ CAUTION alerts you to a hazard or unsafe practice that can result in personal injury or equipment damage.

When equipped with an integral or add-on Automatic Generator Starting System (AGS) control, exhaust carbon monoxide (CO), electric shock, and moving parts hazards are possible due to unexpected starting. Turn off AGS whenever performing maintenance or service, when the vehicle is stored between uses, is awaiting service, or is parked in a garage or other confined area.

ENGINE EXHAUST IS DEADLY

- Inspect for exhaust leaks at every startup and after every eight hours of running.
- Learn the symptoms of carbon monoxide poisoning in the generator set Operator's Manual.
- Never sleep in the vehicle while the generator set is running unless the vehicle is equipped with a working carbon monoxide detector.
- Do not operate the generator set when the vehicle is parked in a confined space, such as a garage.
- The exhaust system must be installed in accordance with the generator set Installation Manual.

- Engine cooling air must not be used for heating the vehicle.

GENERATOR VOLTAGE IS DEADLY

- Disable the automatic genset feature (AGS) of an inverter-charger or other automatic starting device before servicing the genset to avoid electric shock from an unexpected start.
- Generator electrical output connections must be made by a trained and experienced electrician in accordance with applicable codes.
- The generator set must not be connected to shore power (utility). Back-feed to shore power can cause electrocution and damage to equipment. An approved switching device must be used to prevent interconnections.
- Use caution when working on live electrical equipment. Remove jewelry, make sure clothing and shoes are dry, stand on a dry wooden platform or rubber insulating mat and use tools with insulated handles.

DIESEL FUEL IS COMBUSTIBLE

- Do not smoke or turn electrical switches ON or OFF where fuel fumes are present or in areas sharing ventilation with fuel tanks or equipment. Keep flames, sparks, pilot lights, arc-producing equipment and all other sources of ignition well away.
- Fuel lines must be secured, free of leaks and separated or shielded from electrical wiring.

MOVING PARTS CAN CAUSE SEVERE PERSONAL INJURY OR DEATH

- Disable the automatic genset starting feature (AGS) of an inverter-charger or other automatic starting device before servicing the genset to avoid unexpected starting.
- Do not wear loose clothing or jewelry near moving parts such as fans and other moving parts.
- Keep hands away from moving parts.
- Keep guards in place over fans and other moving parts.

BATTERY GAS IS EXPLOSIVE

- Wear safety glasses.
- Do not smoke.
- To reduce arcing when disconnecting or reconnecting battery cables, always disconnect the negative (-) battery cable first and reconnect it last.

FLAMMABLE VAPORS CAN BE IGNITED BY OPERATION OF COACH ELECTRICAL SYSTEMS AND CAUSE DIESEL ENGINES TO OVERSPEED

- Stop the generator set before fueling the coach to reduce the risk of igniting flammable vapors.
- Do not operate the diesel-powered generator set where there are or can be flammable vapors created by fuel spills, gas leaks, etc. Flammable vapors drawn into a diesel engine air intake system can cause the engine to overspeed, which can result in fire, explosion and equipment damage. The owners and operators of the generator set are solely responsible for safe operation.

GENERAL PRECAUTIONS

- Keep children away from the generator set.
- Do not use evaporative starting fluids. They are highly explosive.
- To prevent accidental or remote starting while working on the generator set, press the Stop button and disconnect the battery cables at

the batteries to prevent starting during maintenance and service. (Always disconnect negative [-] first and reconnect last to prevent sparks between tools and vehicle frame.)

- Keep the generator set and its compartment clean. Excess oil and oily rags can catch fire. Dirt and gear stowed in the compartment can restrict cooling air.
- Make sure all fasteners are secure and torqued properly.
- Do not work on the generator set when mentally or physically fatigued or after consuming alcohol or drugs.
- You must be trained and experienced to make adjustments while the generator set is running—hot, moving or electrically live parts can cause severe personal injury or death.
- Used engine oil has been identified by some U. S. state and federal agencies as causing cancer or reproductive toxicity. Do not ingest, inhale, or contact used oil or its vapors.
- Keep multi-class ABC fire extinguishers readily at hand. Class A fires involve ordinary combustible materials such as wood and cloth. Class B fires involve combustible and flammable liquids and gaseous fuels. Class C fires involve live electrical equipment. See NFPA No. 10 (Portable Fire Extinguishers) or equivalent—BS EN 3-7:2004.
- Generator set installation and operation must comply with all applicable local, state and federal codes and regulations.



1. Introduction

ABOUT THIS MANUAL

⚠️WARNING *Improper installation can result in severe personal injury, death and equipment damage. The installer must be qualified to perform the installation of electrical and mechanical equipment.*

⚠️WARNING *This generator set is not a life support system. It can stop without warning. Children, persons with physical or mental limitations, and pets could suffer personal injury or death. A personal attendant, redundant power or an alarm system must be used if generator set operation is critical.*

⚠️CAUTION *Unauthorized modifications or replacement of fuel, exhaust, air intake or speed control system components that affect engine emissions are prohibited by law in the State of California.*

This is the installation manual for the installation of the generator sets listed on the front cover. Proper installation is essential for top performance, safety and compliance. Read through this manual before starting the installation.

This manual addresses the following aspects of the installation:

- Location, Mounting and Ventilation
- Exhaust Connections
- Fuel Connections
- Electrical Connections
- Startup

See the Operator's Manual for operation and maintenance instructions.

Note: *Manuals are updated from time to time to reflect changes in the equipment and its specifications. For this reason, only the copy of the installation manual supplied with the generator set applies.*

OUTLINE DRAWINGS

Refer to the outline drawings beginning on Page 3-1 for installation details.

INSTALLATION CODES AND STANDARDS FOR SAFETY

⚠️CAUTION *The generator set Warranty applies only when the generator set is installed in a Recreational Vehicle.*

The installer bears sole responsibility for the selection of the appropriate generator set, for its proper installation and for obtaining approvals from the authorities (if any) having jurisdiction over the installation. These generator sets meet the basic requirements of the Standard for Safety for Engine Generator Sets for Recreational Vehicles, ANSI/RVIA EGS-1. They are suitable for installation in accordance with:

- NFPA No. 1192—Recreational Vehicles
- NFPA No. 70, Article 551—Recreational Vehicles and RV Parks
- CSA Electrical Bulletin 946—Requirements for Internal Combustion Engine-Driven Electric Generators for Use in Recreational Vehicles

Federal, State and local codes, such as the California Administrative Code—Title 25 (RV installation), could also apply. Installation codes and recommendations can change from time to time and are different in different countries, states and municipalities. It is recommended that the standards in Table 1-1 be obtained for reference.

TABLE 1-1. REFERENCE CODES AND STANDARDS

Code of Federal Regulations: Title 49: Chapter III, Chapter V	Superintendent of Documents P. O. Box 371954 Pittsburgh, PA 15250-7954
National Electrical Code: NFPA No 70, 1192	National Fire Protection Association 470 Atlantic Avenue Boston, MA 02210
ANSI/RVIA-EGS-1	Recreational Vehicle Industry Association 14650 Lee Road Chantilly, VA 22021
California Administrative Code: Title 25, Chapter 3	State of California Documents Section P.O. Box 1015 North Highlands, CA 95660
CAN/CSA-Z240: Recreational Vehicles TIL RV-06	Canadian Standards Association Housing & Construction Materials 178 Rexdale Blvd. Rexdale, Ontario, Canada M9W 1R3



THIS PAGE LEFT INTENTIONALLY BLANK



2. Location, Mounting, and Ventilation

LOCATION

A typical location of the generator set on a vehicle is illustrated in Figure 2-1.

Note: These generator sets are for under-floor installation only. Mounting brackets are provided for securing the generator set to vehicle frame members.

1. Provide access to the front maintenance and service doors and oil drain (bottom) so that all periodic maintenance can be performed in accordance with the Operator's Manual.
2. Provide access for connecting and disconnecting fuel lines, battery cables, remote control wiring and AC wiring.
3. Make sure that frame cross members, exhaust tail pipes and other equipment do not cross underneath the oil drain plug or air intake and discharge openings.
4. Make sure the generator set clears the ground by at least 12 inches (305 mm) to provide adequate ventilation and reduce the amount of dust pulled in by the cooling fan.
5. Protect the air inlet on the side of the generator set from direct road splash.
6. Provide a vapor-resistive and fire-resistive barrier between the generator set and the interior of the vehicle. Use approved materials (26 gauge galvanized steel or equivalent).

WARNING *EXHAUST GAS IS DEADLY. Construct a suitable vapor barrier of approved materials between the generator set and vehicle interior to keep out exhaust gas.*

7. The generator set enclosure must be large enough to provide at least 0.61 inch (15.5 mm) clearance at the top of the generator set, 3.5 inch (89 mm) at the right side (in front of the air inlet), and 0.61 inch (15.5 mm) clearance at all the other the sides. These minimum clearances apply to the thermal or acoustic insulation with which the compartment may be lined.
8. Acoustic/thermal insulation and adhesive must be rated as "Self-Extinguishing." Do not line the bottom of a compartment with insulation, which absorb spilled fuel and oil.

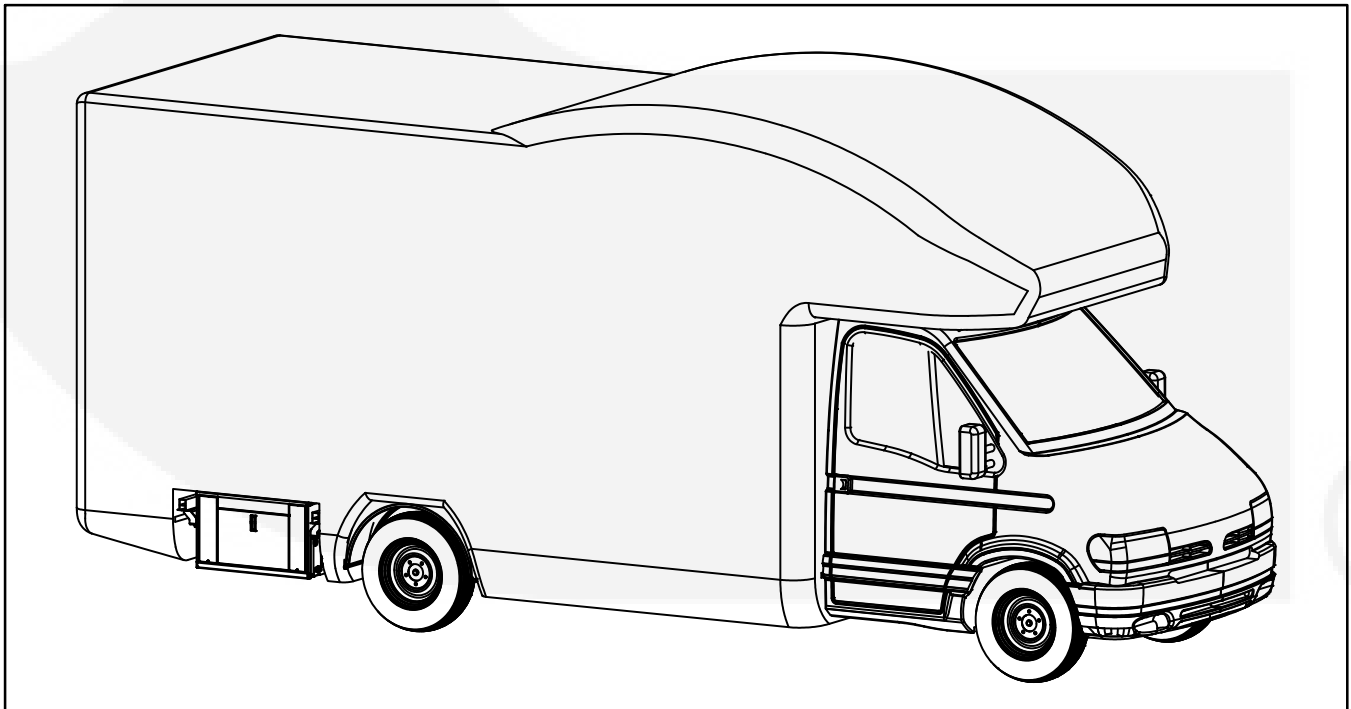

FIGURE 2-1. TYPICAL GENERATOR SET LOCATION

MOUNTING

⚠WARNING Installation of the generator set requires a lifting apparatus. Only use properly rated lifting slings and attachments during the installation of the generator set. Do not exceed the rating of any lifting component. Lifting and lowering operations should only be carried out by properly trained personnel. Wear head, eye, and foot protection during lifting operations.

⚠WARNING The generator set support structure must be designed and installed to support and restrain the dynamic weight of the generator set. Failure to do so can result in the generator

set dropping onto the roadway causing property damage, severe personal injury and death.

If not already assembled, the mounting brackets and vibration isolators are packaged with the generator set (Figure 2-2). Assemble the mounting system on both ends of the generator set.

Note: It is critical for good vibration isolation that the four bolt holes in the vehicle frame line up accurately with the mounting holes in the generator set mounting brackets so that the vibration isolators do not have to be bent to line up with the holes in the vehicle frame.

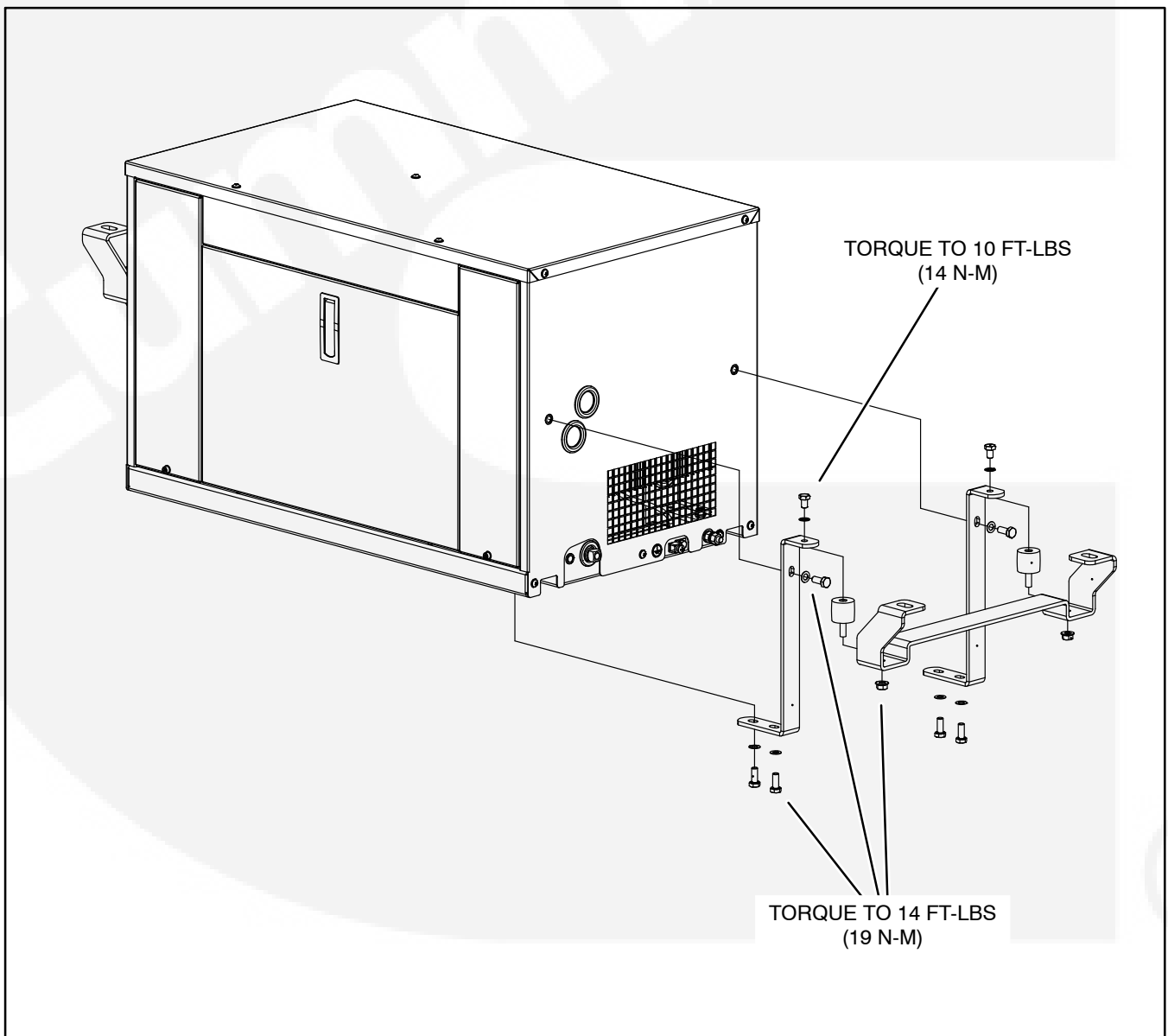

FIGURE 2-2. MOUNTING BRACKET AND VIBRATION ISOLATORS

The generator has a two point lifting system on the outside of the enclosure (Figure 2-3). The genset weight can be found on 7-1. Make provisions accordingly for safe handling. Secure the generator set with 4 bolts to the vehicle structure, which must

be able to resist the dynamic weight of the generator set: ± 3 g-force vertical and ± 1 g-force horizontal. See *Section 7. Specifications* for the weight of the generator set.

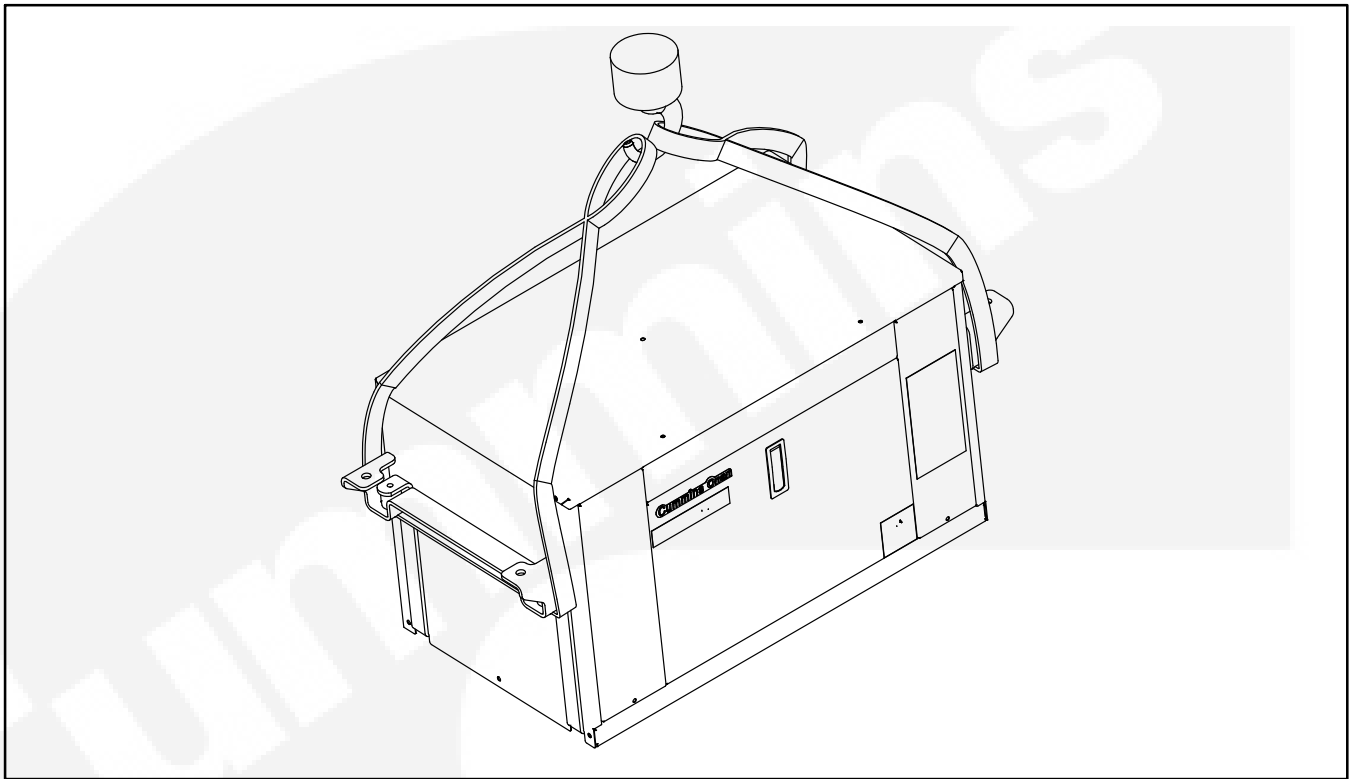
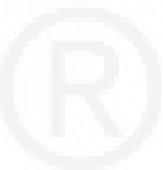

FIGURE 2-3. LIFTING SYSTEM



VENTILATION

Unrestricted air flow for cooling, ventilation and combustion is essential for proper generator set performance and service life. The generator set has a side air intake and bottom hot air discharge (Figure 2-4). Refer to the HOT AIR RECIRCULATION TEST (p. 6-2).

Note: This generator sets is for under-floor installation only.

Make sure frame cross members, exhaust tail pipes and other components do not cross underneath the hot air discharge opening.

Do not block the air inlet and outlet openings with screens, expanded metal or the like; they restrict air flow and can cause the generator set to overheat.

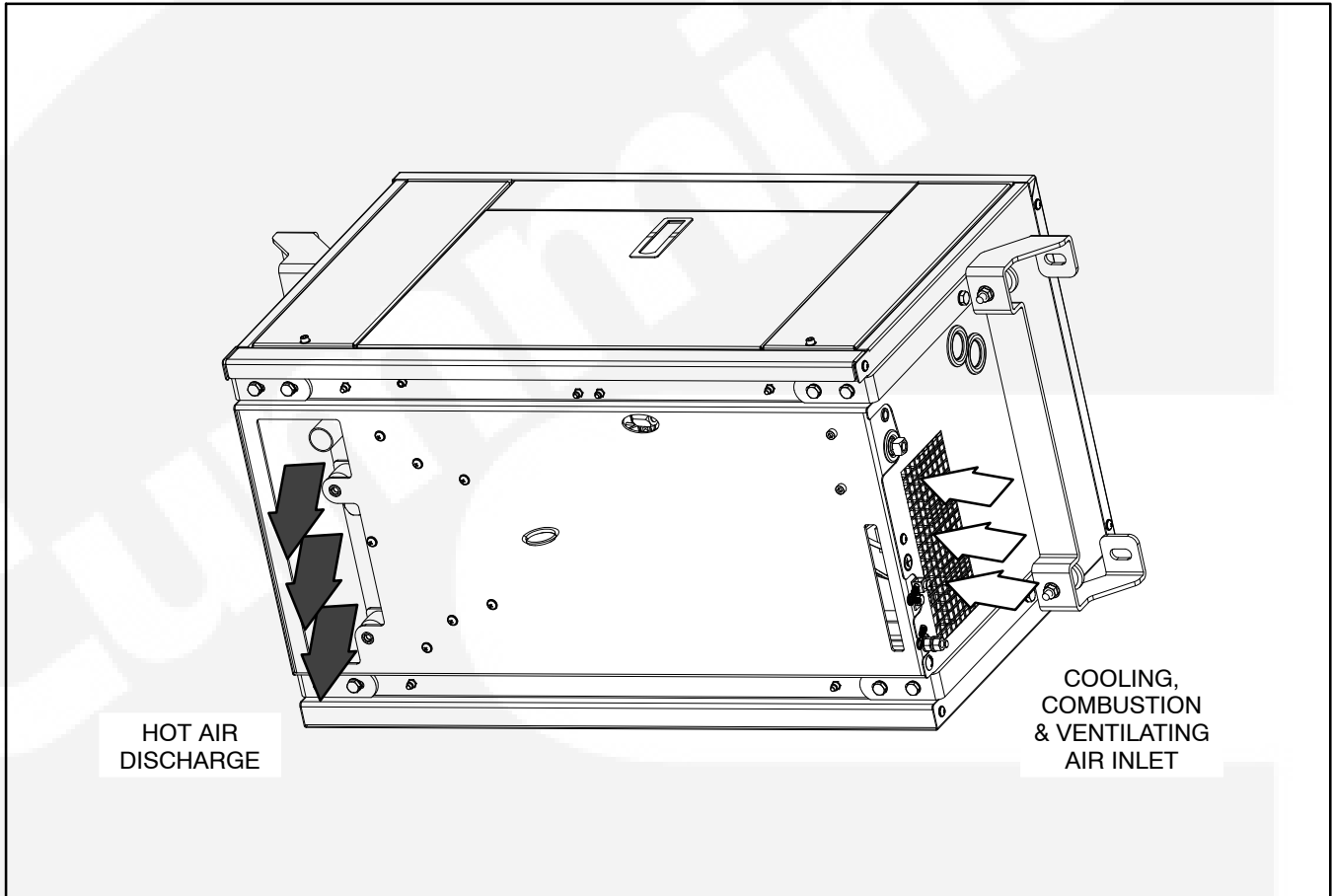

FIGURE 2-4. COOLING, VENTILATION AND COMBUSTION AIR FLOW

3. Exhaust Connections

The exhaust system must be gas-tight and designed to limit entry of exhaust gases into the vehicle.

⚠️ WARNING *EXHAUST GAS IS DEADLY! To keep exhaust gases from entering the vehicle do not terminate the exhaust tailpipe underneath the vehicle or closer than specified to openings into the vehicle or route it such that it is likely to be damaged. Use approved materials and parts only.*

⚠️ CAUTION *Unauthorized modifications or replacement of fuel, exhaust, air intake or speed control system components that affect engine emissions are prohibited by law in the State of California.*

MUFFLER

The muffler is mounted inside the generator set housing. Figure 3-1 illustrates the exhaust outlet collar to which the tail pipe is connected. The muffler is a USDA (Forest Service) spark arrestor and meets RVIA EGS-1 construction requirements.

A generator set without a properly installed and maintained spark arresting exhaust system can cause a forest fire. It is illegal on federal lands. Liability for damage, injury and warranty expense due to the modification of the exhaust system or to the use of unapproved parts is the responsibility of the person performing the modification or installing the unapproved parts. Contact a Cummins Onan distributor for approved exhaust system parts.

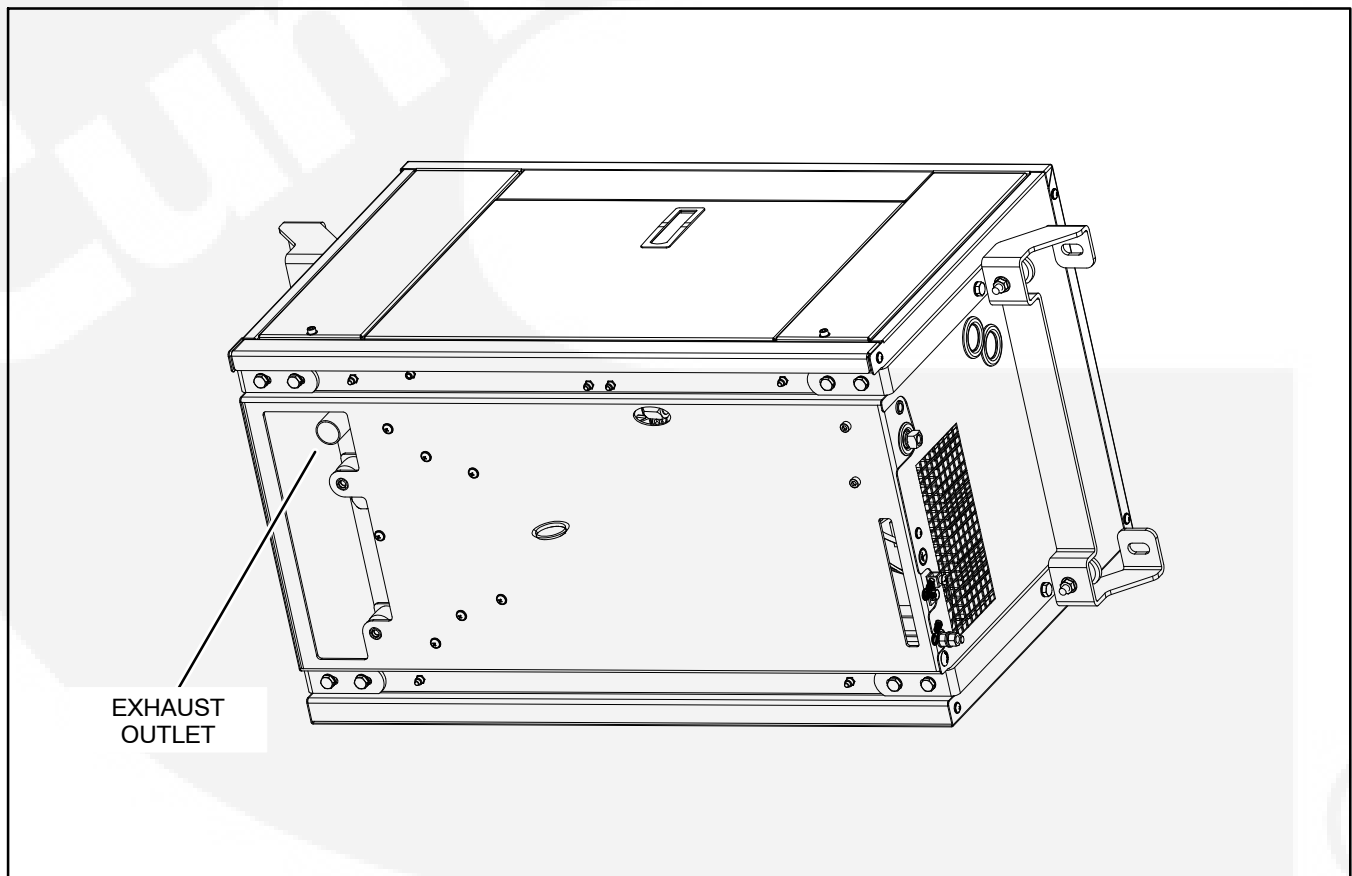

FIGURE 3-1. EXHAUST OUTLET

TAILPIPE

When connecting and routing the tailpipe:

1. Use 1-1/4 inch ID aluminized steel tubing or equivalent for the tailpipe. (Do not use flexible pipe. Flexible pipe is neither gas tight nor durable.)
2. Use U-bolt muffler clamps to connect sections of tailpipe. It is recommended that the overlapping pipe be slotted as shown in Figure 3-2.
3. Use flexible automotive-type tailpipe hangers every 2 to 3 feet (0.6 to 0.9 m). Attach the hangers to steel framework, not to wood or other combustible material.
4. Do not terminate the tailpipe underneath the vehicle. Extend it a minimum of 1 inch (25 mm) beyond the perimeter of the vehicle (Figure 3-3). Support the end of the tailpipe such that it cannot be pushed inward and up under the skirt of the vehicle by backing up into a curb or other obstacle.
5. Do not route the tailpipe such that it will interfere with draining engine oil.
6. Do not route the tailpipe closer than 3 inches (76 mm) to combustible material (wood, felt, cotton, organic fibers, etc.) unless it is insulated or shielded. The temperature rise (above ambient) on adjacent combustible material must not exceed 117°F (65°C).
7. Do not route the tail pipe near fuel lines or fuel tanks or terminate it below or near a fuel fill opening.

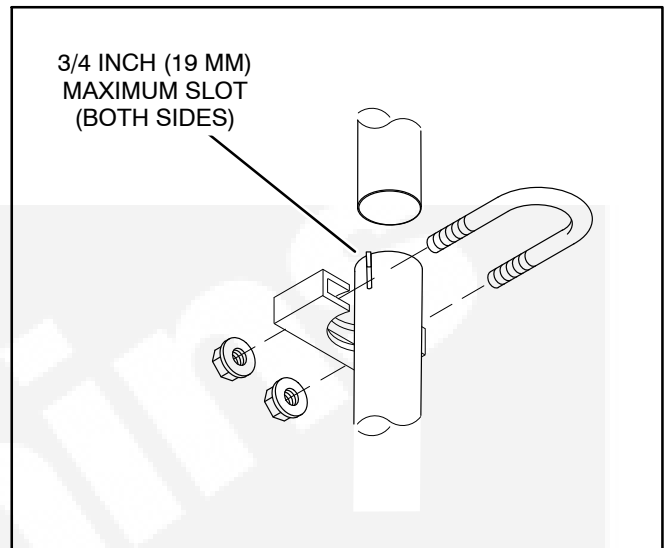

FIGURE 3-2. EXHAUST TAILPIPE CONNECTIONS

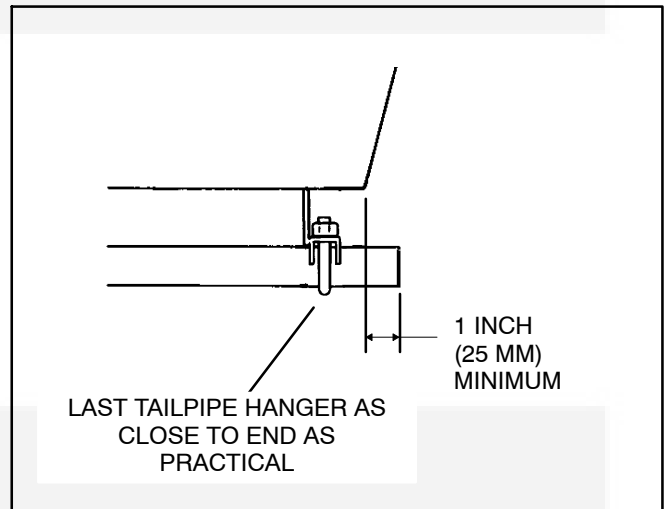

FIGURE 3-3. TERMINATING EXHAUST TAILPIPE

8. Do not terminate the tailpipe such that it is closer than 6 inches (153 mm) to any opening into the vehicle interior (door, window, vent). See Figure 3-4.
9. Route the tailpipe such that it will not likely be struck when the vehicle is moving. Keep it out of the approach and departure angles of the vehicle and above the axle clearance line.
10. Do not connect the generator set to the vehicle engine exhaust system.

▲ CAUTION *Interconnecting the engine exhaust systems will allow exhaust condensates and soot to migrate into the engine that is idle, causing engine damage.*

11. Exhaust back pressure under full load must not exceed 21.7 inches (550 mm) water column (WC).

▲ CAUTION *Excessive back pressure can cause loss of performance and engine damage.*

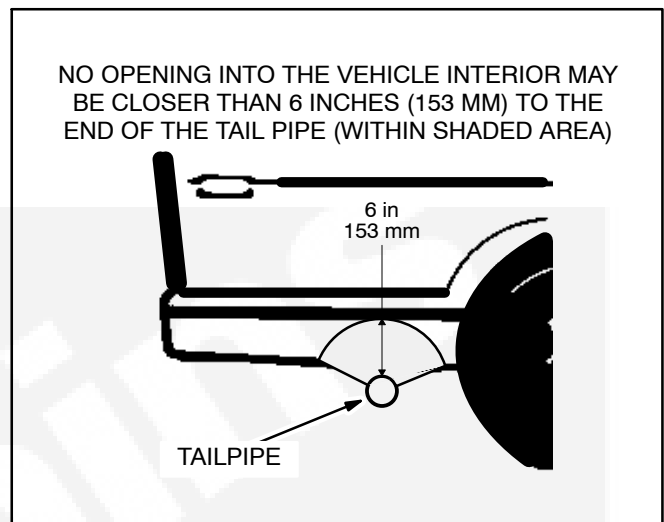

FIGURE 3-4. MINIMUM DISTANCES TO OPENINGS



THIS PAGE LEFT INTENTIONALLY BLANK



4. Fuel Connections

⚠ WARNING Diesel fuel is a combustible and can cause severe personal injury or death. Do not smoke or allow any flame, spark, pilot light, arc-producing equipment, electrical switch or other ignition source around fuel or fuel components, or in areas sharing ventilation. Keep a type ABC fire extinguisher handy.

Do not interconnect generator set and vehicle engine fuel lines. Follow the vehicle chassis manufacturer's instructions when making connections to the vehicle engine fuel tank.

⚠ CAUTION Either or both engines could starve for fuel if the generator set and vehicle engine fuel lines are interconnected. Always use separate fuel lines or a separate fuel tank for the generator set.

To prevent the generator set from running the vehicle out of fuel, do not extend the generator set fuel pickup tube down into the fuel tank as far as the pickup tube for the vehicle engine.

Fuel lines (supply and return) must have at least a 1/4 inch (6.4 mm) ID. See Figure 4-1 for connections at the generator set.

Run the fuel line at or above the top of the fuel tank to reduce the risk of siphoning fuel out of the tank if the line should break. The maximum fuel pump lift is 36 inches (1 meter).

Route fuel lines away from electrical wiring and hot engine exhaust components. Fuel lines should be accessible for inspection and replacement, protected from damage and secured to prevent kinking, contact with sharp edges and chafing due to vibration.

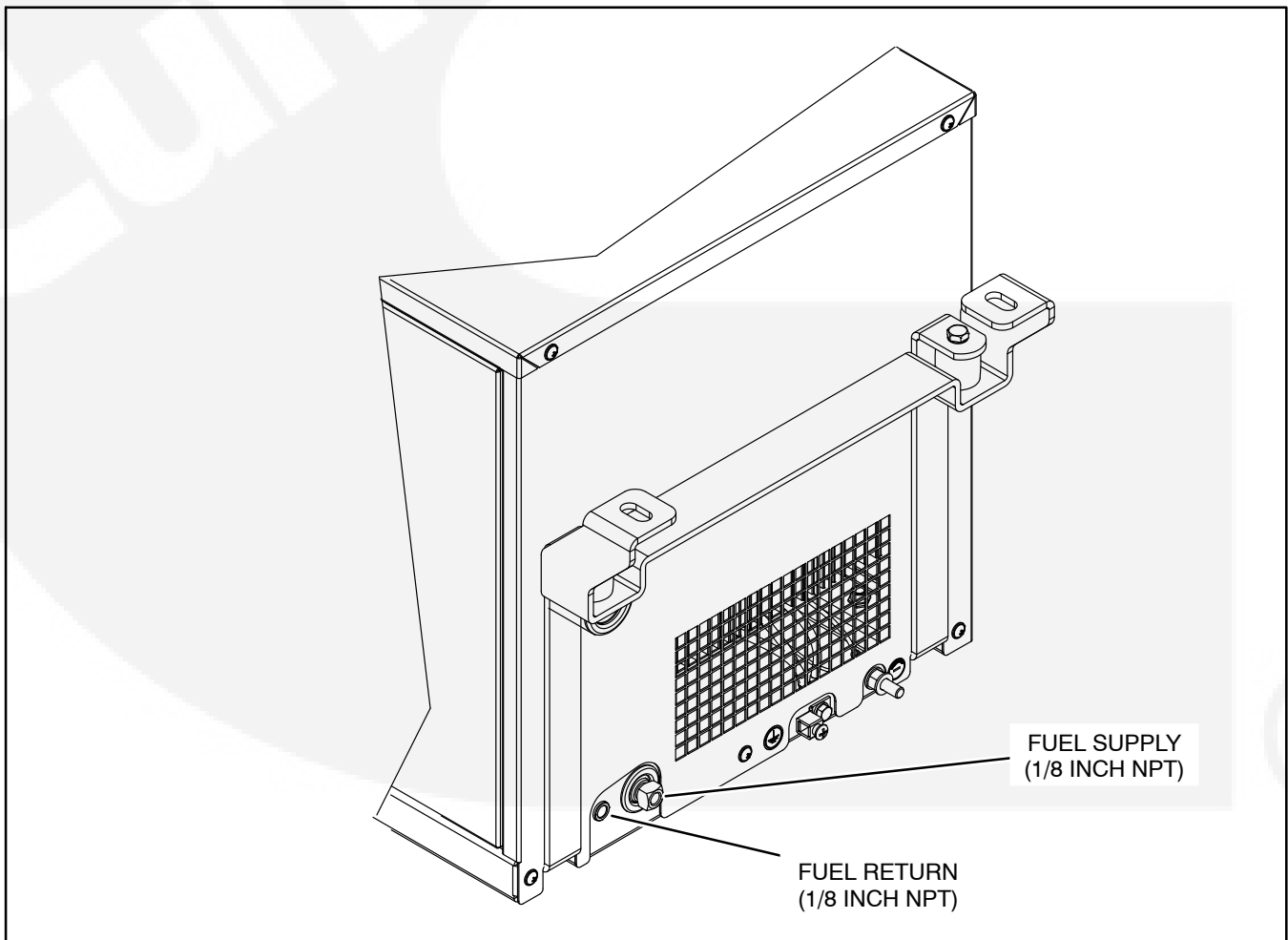

FIGURE 4-1. FUEL CONNECTIONS



THIS PAGE LEFT INTENTIONALLY BLANK



5. Electrical Connections

AC POWER OUTPUT

⚠WARNING *Accidental starting of the generator set can cause severe personal injury or death. Do not connect the starting battery until so instructed in Installation Review and Startup.*

Wiring Methods

The generator set is equipped with a terminal block for AC power output connections (Figure 5-1). AC wiring methods must be in accordance with the National Electrical Code.

⚠WARNING *EXHAUST GAS IS DEADLY! Seal all wiring openings into the vehicle interior to keep out exhaust gas.*

Routing AC wiring with fuel lines can lead to electrocution or fire. Keep AC wiring away from fuel lines.

Faulty grounding can lead to electrocution or fire. Grounding must be in accordance with applicable codes.

Note the following:

1. Have a trained and experienced electrician supervise and inspect the installation of all AC wiring.
2. Secure only one lead at each AC output terminal. Use 10 AWG (5.3 mm²) conductors. Torque the terminals to 9.7 in-lbs (1.1 N-m). When stranded conductors are used, it is recommended that copper ferrules, available for the various wire gauges, be crimped on the stripped ends of the conductors to facilitate terminal connections. Otherwise, re-torque the terminals after a few minutes in the event that individual strands spread out, loosening the connection.
3. Use vibration-proof switches and controls to prevent the opening and closing of circuits while the vehicle is in motion.
4. Use rain-tight conduit, conduit connectors and junction boxes for all exterior wiring.

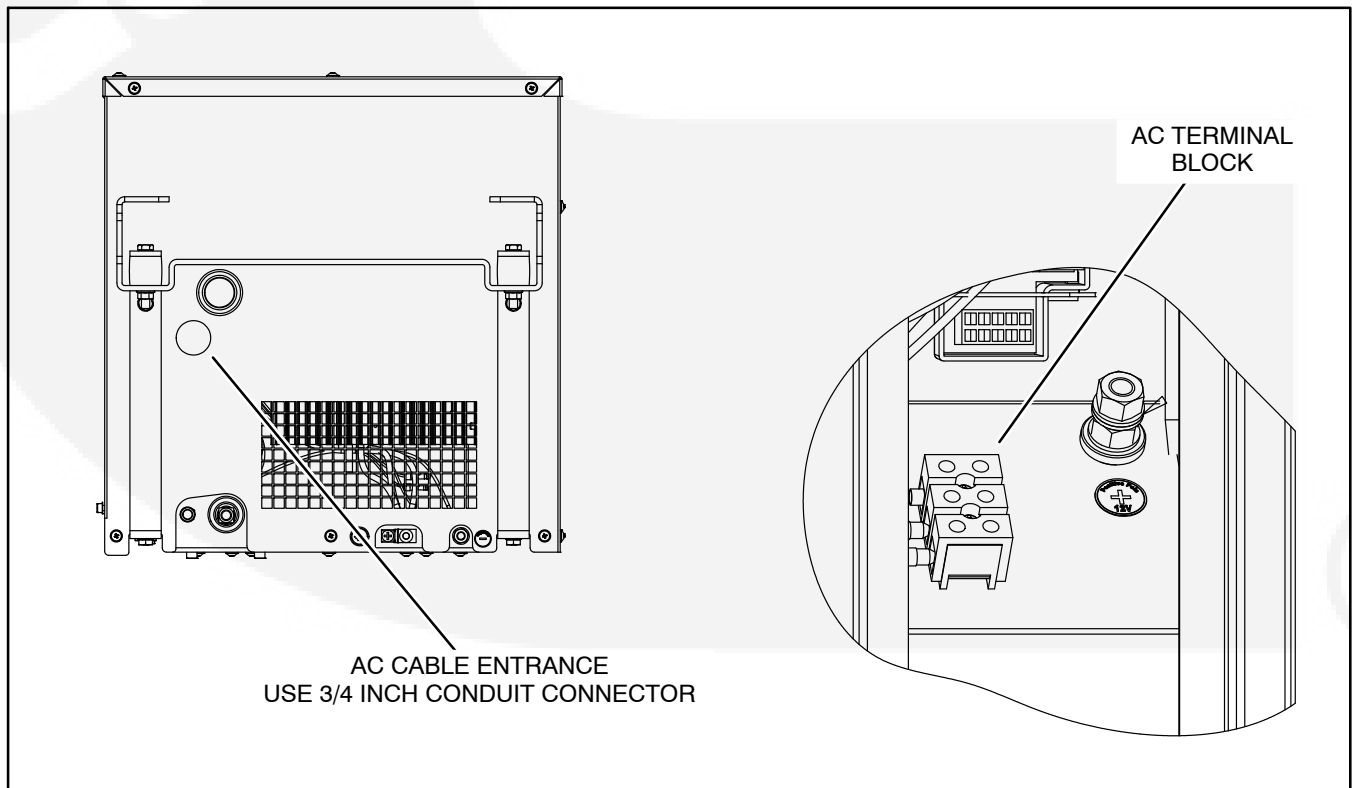

FIGURE 5-1. AC CONNECTIONS

5. Provide ground fault circuit interrupters (GFCIs) or residual current devices (RCDs) for all convenience power receptacles.
6. Seal all conduit openings into the vehicle interior to keep out exhaust gas. Apply silicone rubber or equivalent sealant inside and outside each conduit connector. (Flexible conduit is not vapor-tight and will allow exhaust gas to enter along the wires if not sealed.)
7. Route or protect AC wiring so that it will not be cut or abraded, exposed to hot surfaces or damaged by road debris. Keep AC wiring away from fuel lines and control wiring (see Remote Control).

8. Connect the grounding terminal in accordance with applicable codes.

Connecting the Vehicle to Utility Power

⚠️WARNING *Interconnecting the generator set and public utility can lead to electrocution of utility line workers, equipment damage and fire. Use an approved switching device to prevent interconnections.*

A vehicle with provisions for connecting utility (shore) power must have an approved device to keep the generator set and utility from being interconnected. See Figure 5-2 for typical connections.

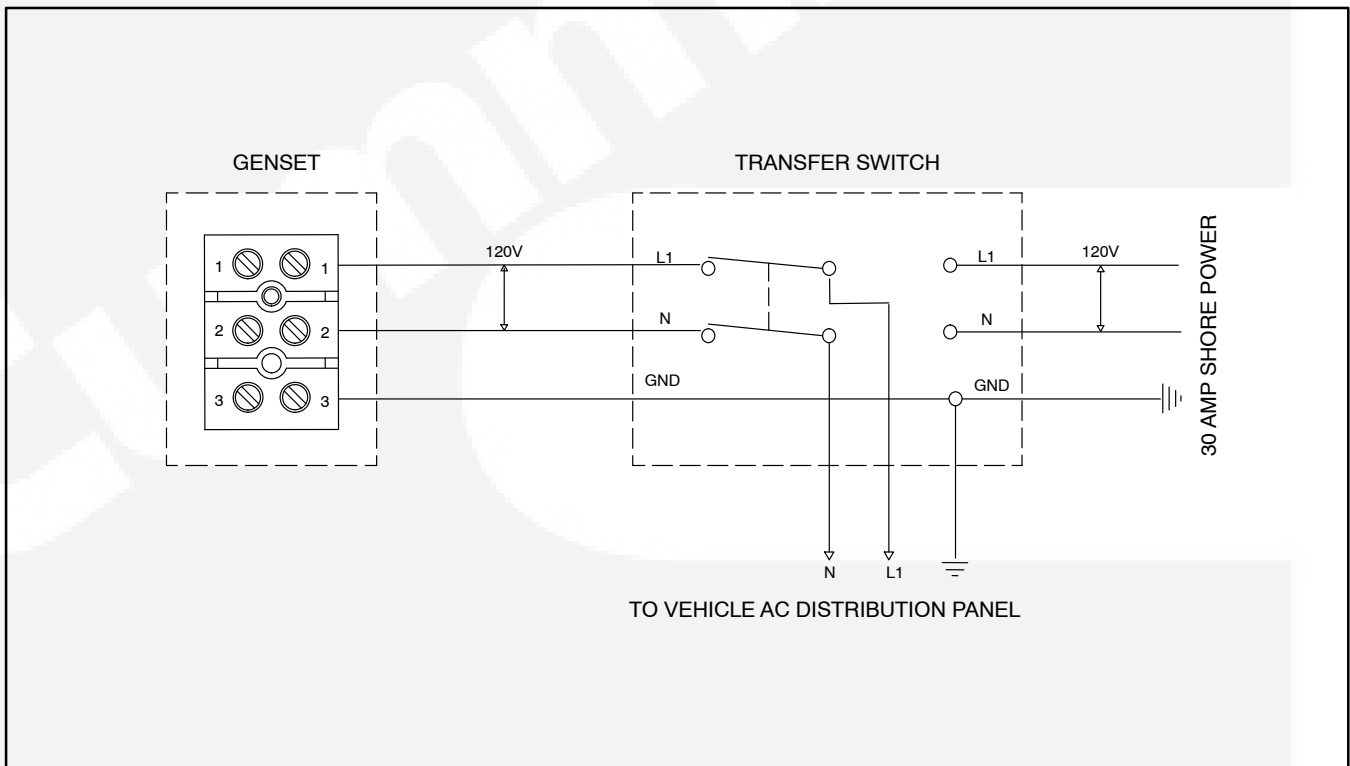

FIGURE 5-2. TYPICAL AC CONNECTIONS WITH SHORE POWER AND TRANSFER SWITCH

REMOTE OPERATOR PANEL

The remote operator panel and plug-in wiring harness are packaged with the generator set (Figure 5-3). Mount the operator panel at a location in the vehicle that is convenient for operation of the generator set.

Note: HDZAA is capable of supporting only one Display. Also, additional remote Start/Stop switches are not supported.

⚠WARNING EXHAUST GAS IS DEADLY! Seal all wiring harness openings into the vehicle interior to keep out exhaust gas.

When routing the harness:

1. Keep the control wiring harness away from AC wiring to reduce the possibility of erratic operation due to induced signals.
2. Seal the hole where the wiring harness enters the interior of the vehicle to keep out exhaust gas. Use silicone rubber or an equivalent type of sealant.
3. Snap the harness connectors into the mating generator set and remote operator panel connectors.

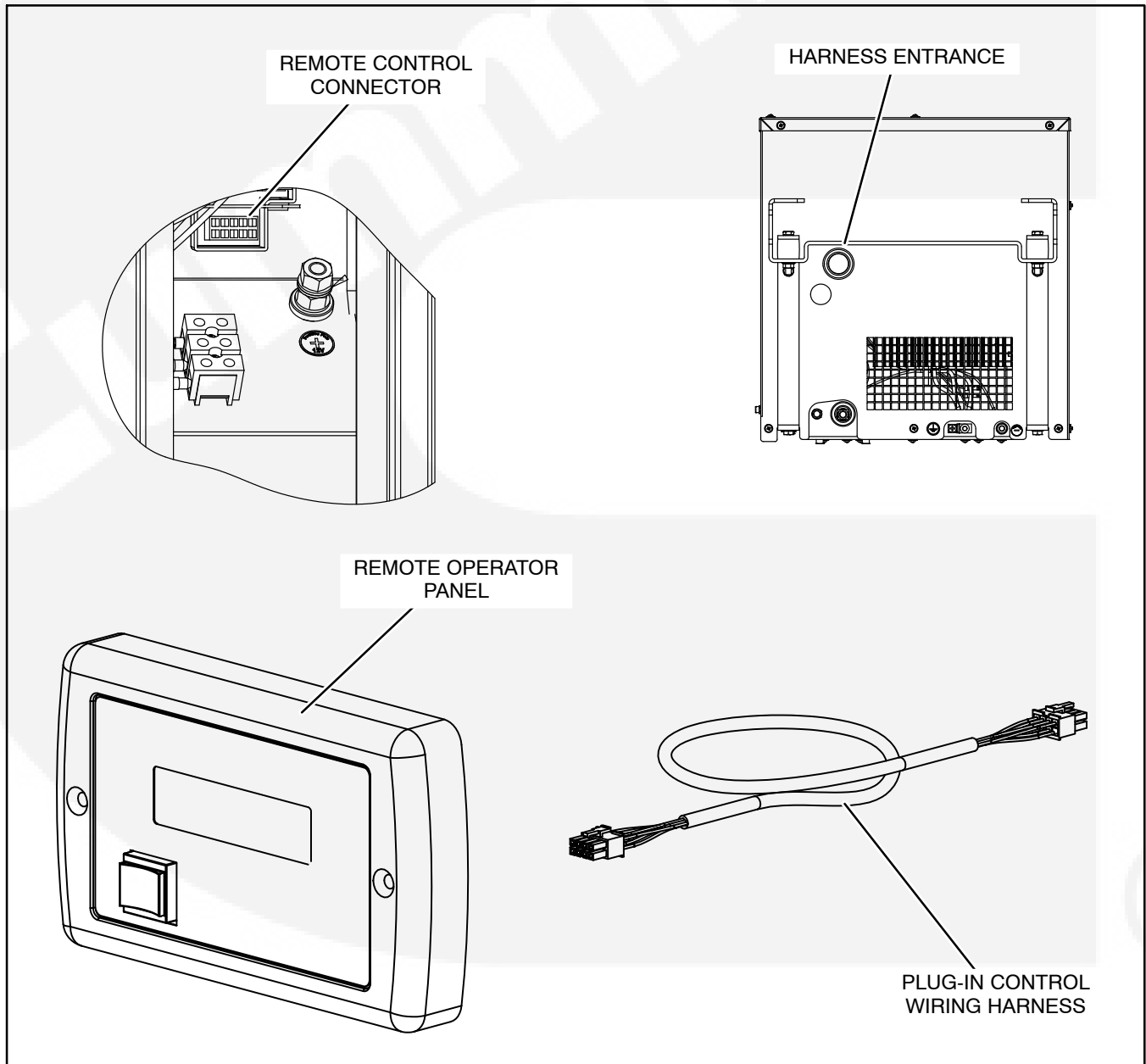

FIGURE 5-3. REMOTE OPERATOR PANEL

⚠ CAUTION *Auto Generator Start capability is not available on this generator.*

Batteries

To prevent accidental starting of the generator set during installation, do not connect the battery cables at the battery until so instructed in *Section 6. Installation Review and Startup*.

⚠ WARNING *Accidental starting of the generator set can cause severe personal injury or death. Do not connect the starting battery until so instructed in Installation Review and Startup.*

Battery Capacity

The generator set has a 12 VDC, negative-ground control and starting system. See *Section 7. Specifications* for the requirements for cranking batteries.

Battery Charging

The vehicle manufacturer must provide means for battery charging.

Battery Compartment

Batteries must be mounted in a separate compartment from that of the generator set and away from spark-producing equipment. An enclosed compartment must have openings of at least 1.7 square inches (11 square centimeters) at the top and bottom for ventilation of battery gasses. Batteries should be mounted such that spills and leaks will not drip acid on fuel lines, wiring and other equipment that could be damaged.

⚠ WARNING *Arcing can ignite the explosive hydrogen gas given off by the battery, causing severe personal injury. The battery compartment must be ventilated and must isolate the battery from spark-producing equipment.*

Generator Set Battery Terminals

Terminate the battery cables at the generator set with ring terminals sized for 8 mm threaded-stud terminals (Figure 5-4). Permanently mark each end of each cable as to its polarity, positive (+) or negative (-). After making sure the battery cables are not connected at the battery, connect the battery and grounding cables to the generator set. Secure the insulating boot on the positive (+) cable terminal.

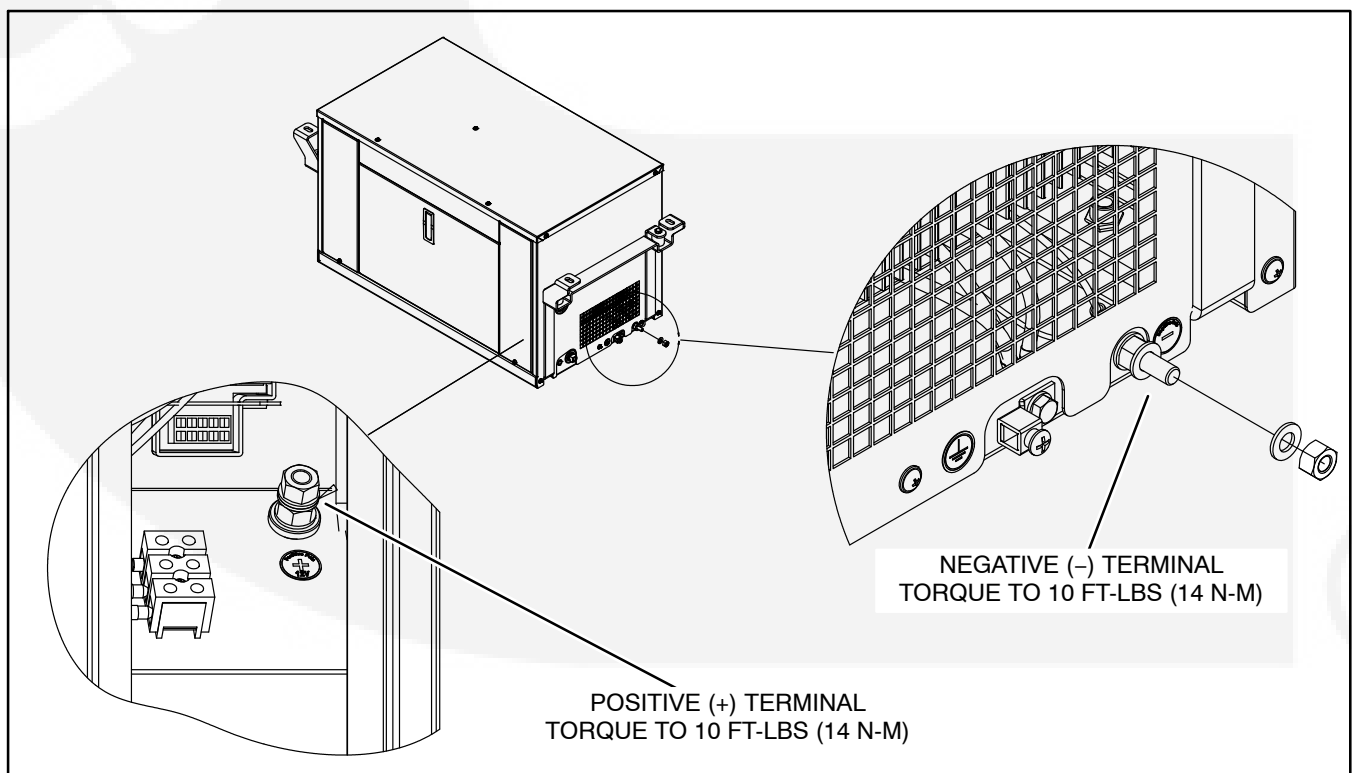

FIGURE 5-4. GENERATOR SET BATTERY TERMINALS

Battery Cables

Battery wiring methods must be in accordance with the National Electrical Code.

Size battery cables according to Table 5-1. The current path between the generator set and the negative (-) battery terminal must also be able to carry full cranking current without causing excessive voltage drop. It is highly recommended that a full-length cable be used to connect the generator set to the negative (-) battery terminal (Figure 5-5).

TABLE 5-1. BATTERY CABLE SIZES FOR AMBIENT TEMPERATURES TO -20° F (-29° C)

TOTAL CABLE LENGTH, FEET (METERS)*	CABLE SIZE, AWG (mm ²)
0 to 25 (0 to 7.6)	0
26 to 70 (8 to 21.3)	00
73 to 90 (22.25 to 27.4)	000

*Battery cable lengths are total lengths from the battery to the generator back to the battery.
Based on 300 amp cranking amperage.

If the vehicle frame is used as the path between the negative (-) battery terminal and the generator set, all frame members in the path of battery cranking currents must have substantial cross sections. The electrical resistance of riveted or bolted frame joints must also be carefully considered, especially if the joints will be exposed to corrosive conditions. A cable sized according to Table 5-1 must be used to connect the frame to the designated negative (-) terminal on the generator set.

Route battery cables away from fuel lines and hot engine exhaust components. Battery cables should be accessible for inspection and replacement, protected from damage and secured to prevent chafing due to vibration.

Provide insulating boots for the positive (+) battery cable terminals.

⚠WARNING *Routing battery cables with fuel lines can lead to fire and severe personal injury or death. Keep battery cables away from fuel lines.*

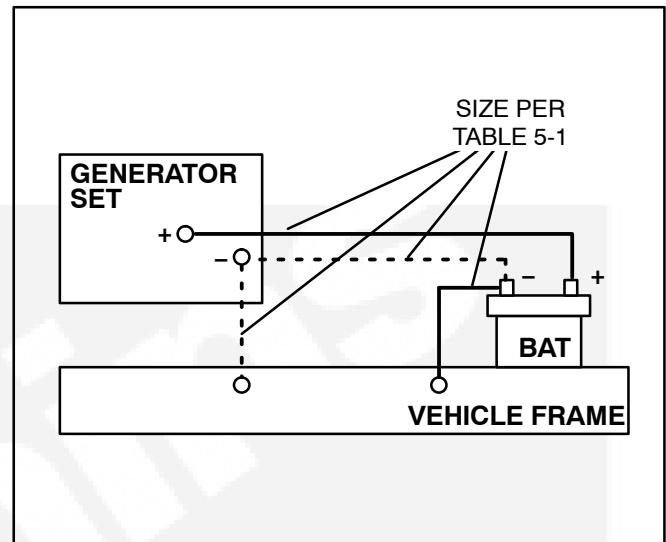

FIGURE 5-5. BATTERY CONNECTIONS

Generator Set Grounding Terminal

If required by code, bond the generator set to the vehicle chassis with an 8 AWG (10 mm²) stranded

copper conductor using the grounding terminal on the generator set (Figure 5-6).

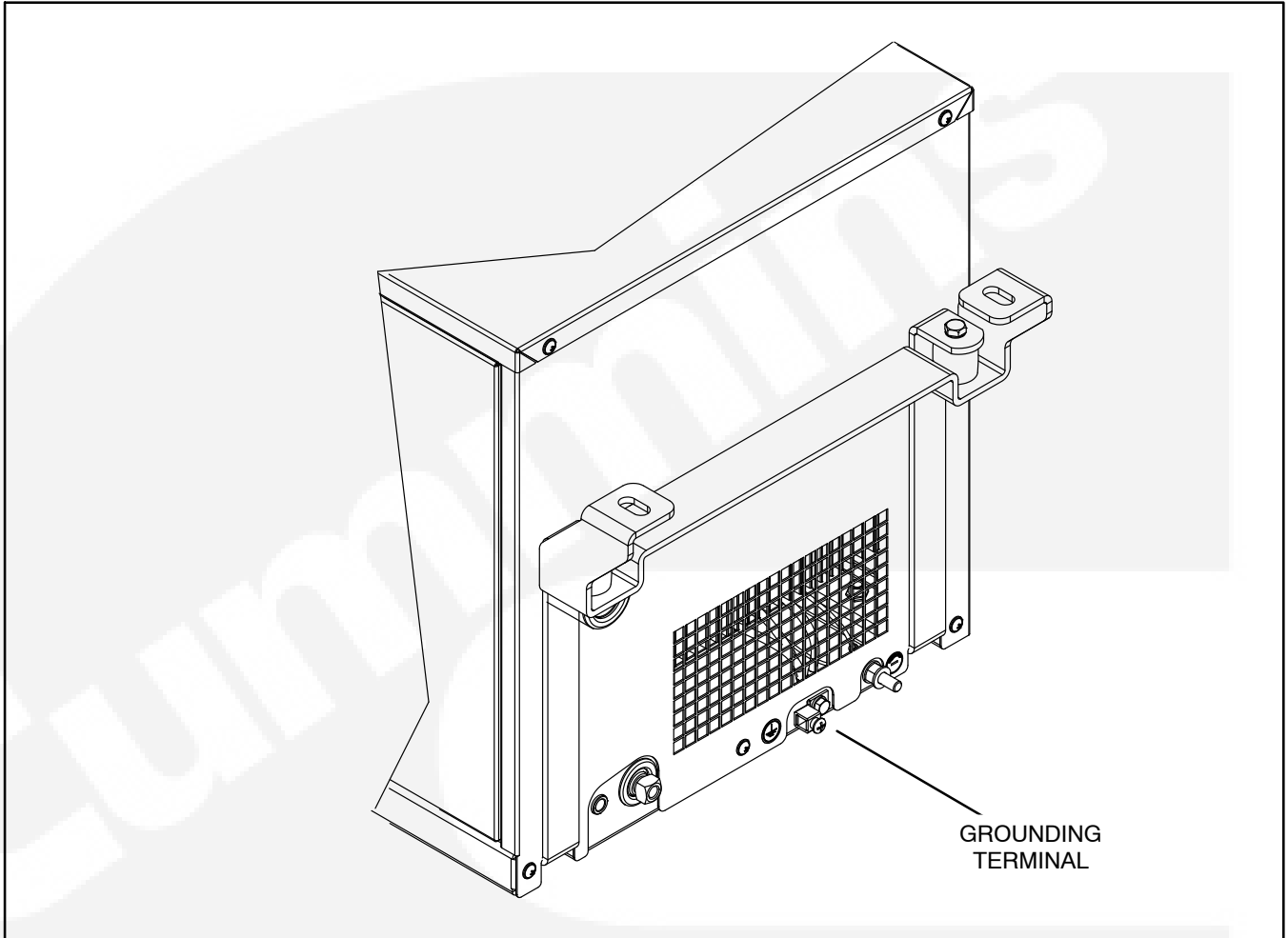

FIGURE 5-6. GENERATOR SET GROUNDING TERMINAL

6. Installation Review and Startup

INSTALLATION REVIEW AND STARTUP

⚠WARNING *Flames, sparks and arcing at battery terminals, light switches and other equipment can ignite battery gas causing severe personal injury—Ventilate battery area before working on or near battery—Wear safety glasses—Do not smoke—Switch work light ON or OFF away from battery—Stop generator set and disconnect charger before disconnecting battery cables—Disconnect negative (-) cable first and reconnect last.*

First, review the following items that can be checked before the generator set is started up. Make necessary repairs and reconnections.

Second, read the Operator's Manual and perform the maintenance and pre-start checks instructed. The generator set is shipped with engine oil.

⚠WARNING *EXHAUST GAS IS DEADLY! Do not operate the generator set when the vehicle is indoors unless there is ample fresh air ventilation.*

Third, connect the battery (negative [-] cable last), start the generator set and continue by reviewing the remaining items that require the generator set to be in operation. Make necessary repairs and reconnections. Do not place the generator set in service until all installation review items have been checked off.

- [] The generator set is securely bolted in place.
- [] There is proper clearance all around the generator set.
- [] The generator set is located outside the interior space of the vehicle and is separated by approved vapor and fire-resistive materials.
- [] The generator set clears the ground by at least 12 inches (305 mm).
- [] The generator set is protected from direct road splash.
- [] The air inlet and outlet openings are free of obstructions.
- [] The front maintenance and service access panels are easily removable for conducting periodic maintenance in accordance with the Operator's Manual.
- [] There is easy access to the generator set Stop Switch through the maintenance access opening.
- [] There is easy access for draining engine oil.
- [] There is easy access for changing the air filter and fuel filter and adding oil.
- [] There is easy access for cleaning the spark-arrestor.
- [] All tailpipe connections are tight and all hangers and support straps are secure.
- [] The tailpipe terminates at least 1 inch (25 mm) beyond the perimeter of the vehicle and is at least 6 inches (153 mm) away from any opening into the vehicle.
- [] The tailpipe is routed such that it is not likely to be struck while the vehicle is moving.
- [] All wiring holes into the vehicle interior (inside and outside conduit connectors) are sealed to keep out exhaust gas.
- [] AC output connections have been made properly.
- [] Battery capacity meets minimum requirements.
- [] Battery cable gauges meet minimum requirements. Insulating boots on the positive (+) battery cable terminals have been secured.
- [] Battery cables have been secured at sufficient intervals to prevent chaffing and contact with sharp edges, fuel lines and hot exhaust parts.
- [] The generator set is properly grounded to the vehicle chassis.
- [] All fuel connections are tight.
- [] Fuel lines have been secured at sufficient intervals to prevent chaffing and contact with sharp edges, electrical wiring and hot exhaust parts.
- [] The remote operator panel functions properly to start and stop the generator set and monitor operation.

HOT AIR RECIRCULATION TEST

⚠WARNING *EXHAUST GAS IS DEADLY! Do not operate the generator set when the vehicle is indoors unless there is ample fresh air ventilation.*

If overheating of the generator set persists, it may be due to hot air recirculation. Verify the condition by conducting the following test:

Test Method

1. Conduct the test in a well ventilated space in which carbon monoxide cannot accumulate, but that is protected from cross drafts that could affect temperature measurements.
2. Measure temperatures with shielded thermocouples not heavier than No. 24 AWG (0.25 mm²). A 2 inch diameter white PVC pipe 6 inches long is a good thermocouple shield. See Figure 6-1.
3. Measure generator set inlet air temperature with a thermocouple secured about 1 inch from the face of the air inlet.
4. Measure outside ambient air temperature with a thermocouple not more than 4 feet (1.2 meters) from the generator set and at approximately the same height. Make sure the thermocouple will not be affected by warm air discharged from the generator set or by sunlight.

5. Close all generator set enclosure doors, start the generator set, connect 3.2 kW of constant load and run for at least 90 minutes. If air conditioners are used as loads, make sure they stay on and do not cycle during the test.
6. Record temperatures at 15 minute intervals. See Table 6-1 for an example of how the data can be arranged for recording and analysis.

TABLE 6-1. TEMPERATURE DATA

THERMOCOUPLE LOCATION	TEMPERATURE C° (F°)				
	Time Of Reading				
OUTSIDE AMBIENT AIR					
GENERATOR SET AIR INLET					

Test Requirement

Inlet air temperature must not exceed ambient air temperature by more than 15°F (8.3°C). A rise in inlet air temperature of more than this requires that steps be taken to reduce air recirculation.

Note: On very hot days generator set capacity could be noticeably affected if the air temperature rise in this test is close to the maximum permitted rise.

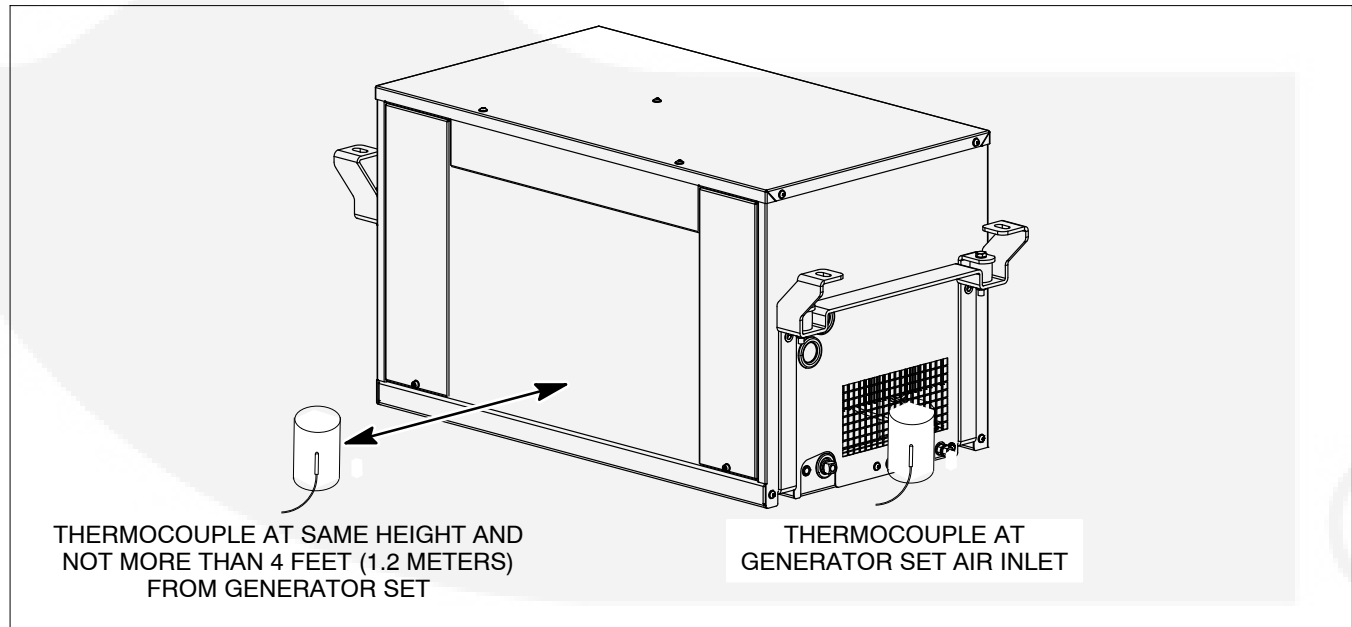

FIGURE 6-1. THERMOCOUPLE LOCATIONS

7. Specifications

GENSET CONTROL: Integrated Microprocessor-Based Engine and Generator Controller and AC Output Inverter	
GENERATOR: Three-Phase, Permanent Magnet, 3600 RPM	
Power (@1.0 power factor)	See Nameplate
Voltage	120
Frequency	60 Hz
Number of Phases	1
Current	26.7 amps
FUEL CONSUMPTION:	
@ 1 kW	0.20 gph (0.76 lph)
@ 2 kW	0.27 gph (1.03 lph)
@ 3 kW	0.36 gph (1.37 lph)
ENGINE: Single-Cylinder, Direct-Injection, Air-Cooled, 4-Stroke Diesel	
Bore	3.15 in (80 mm)
Stroke	2.72 in (69 mm)
Displacement	21 in ³ (347 cc)
Compression Ratio	22:1
Fuel Injection Timing (BTDC)	16°
Fuel Nozzle Injection Pressure	2900±174 psi (200±12 bar)
Cylinder Compression Test	290 to 319 psi (20 to 22 bar)
Valve Lash: Intake & Exhaust (cold)	0.004 in (0.1 mm)
Oil Capacity	1.16 quarts (1.1 liter)
DC SYSTEM:	
Nominal Battery Voltage	12 volts
Minimum Battery Capacity CCA (Cold Cranking Amps)	475 amps down to 0°F (-17°C) 650 amps down to -20°F (-29°C)
WEIGHT (WET): 205 lbs (93 kg)	
SIZE (L x W x H): 30.17 x 17.3 x 18.02 in (766.4 x 439.4 x 457.7 cm)	
SOUND LEVEL: 71dB(A) @ 2kW @ 10 ft (3 meters)	

LOAD ON ENGINE

- Operating the engine for a lengthy period off-load or at very low loads can affect its running quality. We therefore recommend a minimum engine load of 15%.
- If operated at such low loads, it is best to operate the engine at a significantly higher load for a short period before switching it off.



THIS PAGE LEFT INTENTIONALLY BLANK



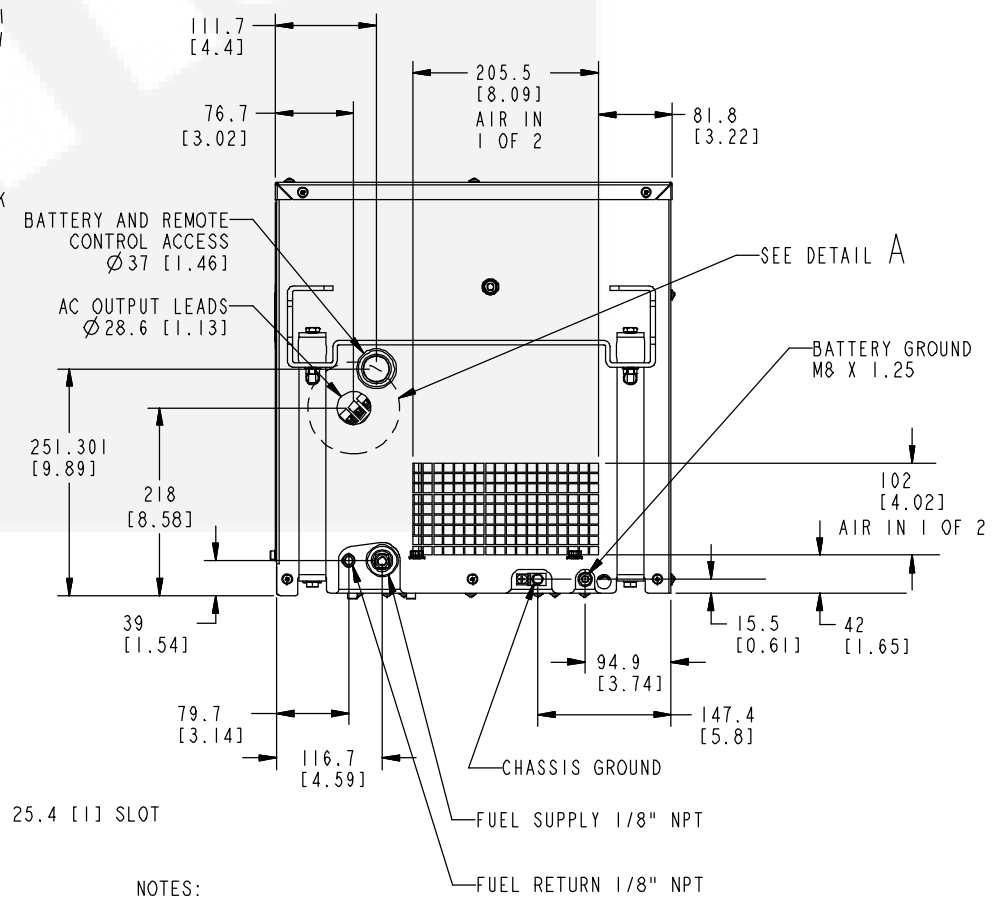
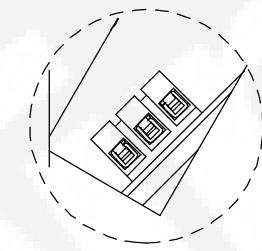
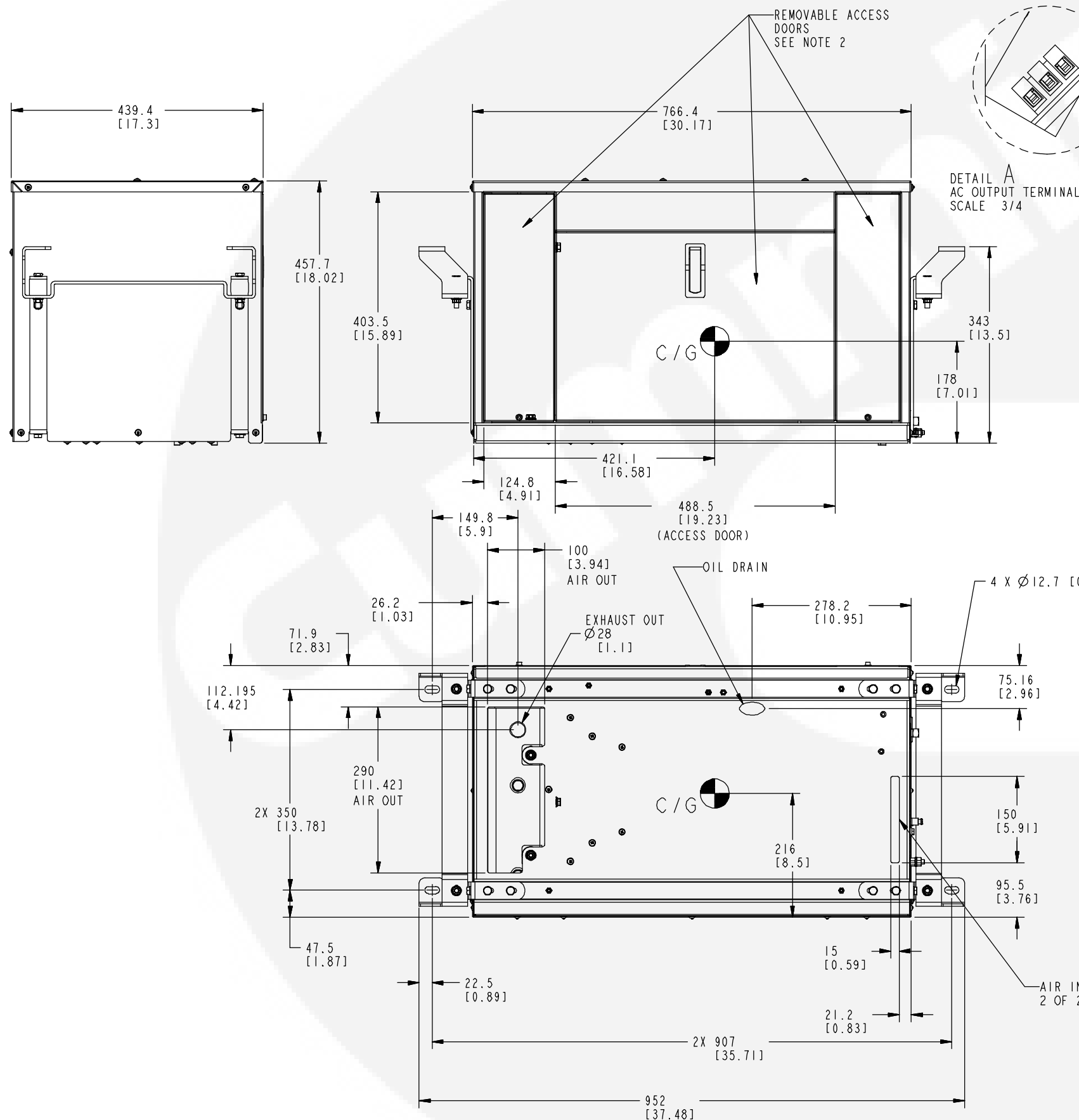

NOTES:

1. DIMENSIONS IN BRACKETS ARE INCHES.
2. COMPARTMENT ACCESS SHALL ALLOW REMOVAL AND REPLACEMENT OF THREE ACCESS DOORS. THIS ALLOWS ACCESS TO THE FOLLOWING:
 - OIL FILL, CHECK, AND DRAIN
 - AIR CLEANER ELEMENT
 - FUEL FILTER
 - AC TERMINAL BLOCK
 - REMOTE CONTROL CONNECTOR
 - BATTERY POSITIVE POST
 - ENGINE STOP SWITCH
3. MIN UNIT CLEARANCES FROM COMPARTMENT SURFACES:

-TOP	15.5mm	.61 IN
-ELECTRICAL END (RIGHT)	15.5mm	.61 IN
-EXHAUST END (LEFT)	15.5mm	.61 IN
-SERVICE SIDE (FRONT)	15.5mm	.61 IN
-BACKSIDE	15.5mm	.61 IN

*3.5 INCH MIN CLEARANCE FOR AIR INTAKE IS REQUIRED FOR BOTTOM HALF OF GENSET
 *ALLOW SUFFICIENT COMPARTMENT AREA FOR ACCESS TO FUEL, GROUND, BATTERY, AC LINES, AND CONTROL PANEL HARNESS.
4. MIN FREE AIR INLET: 232 CM² 36 IN²
5. UNIT WEIGHT: 93 KG (205 LBS)

500-4709

OUTLINE DRAWING—SHEET 1 OF 2

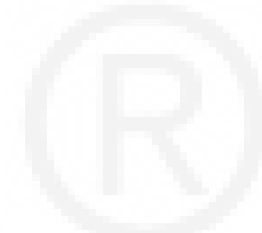

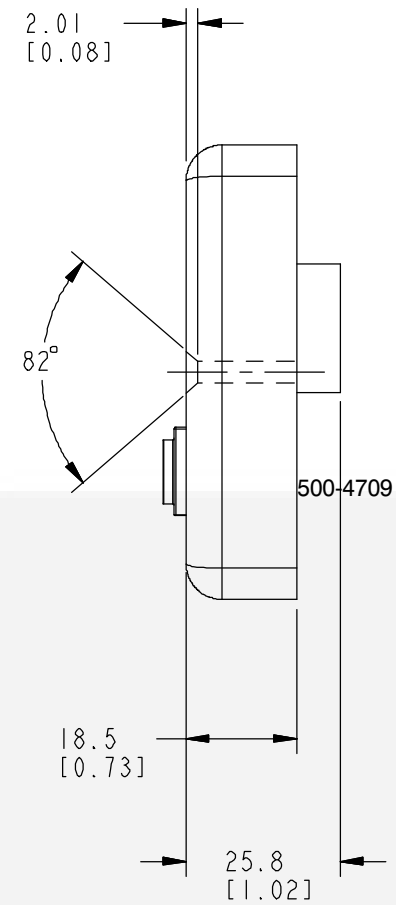
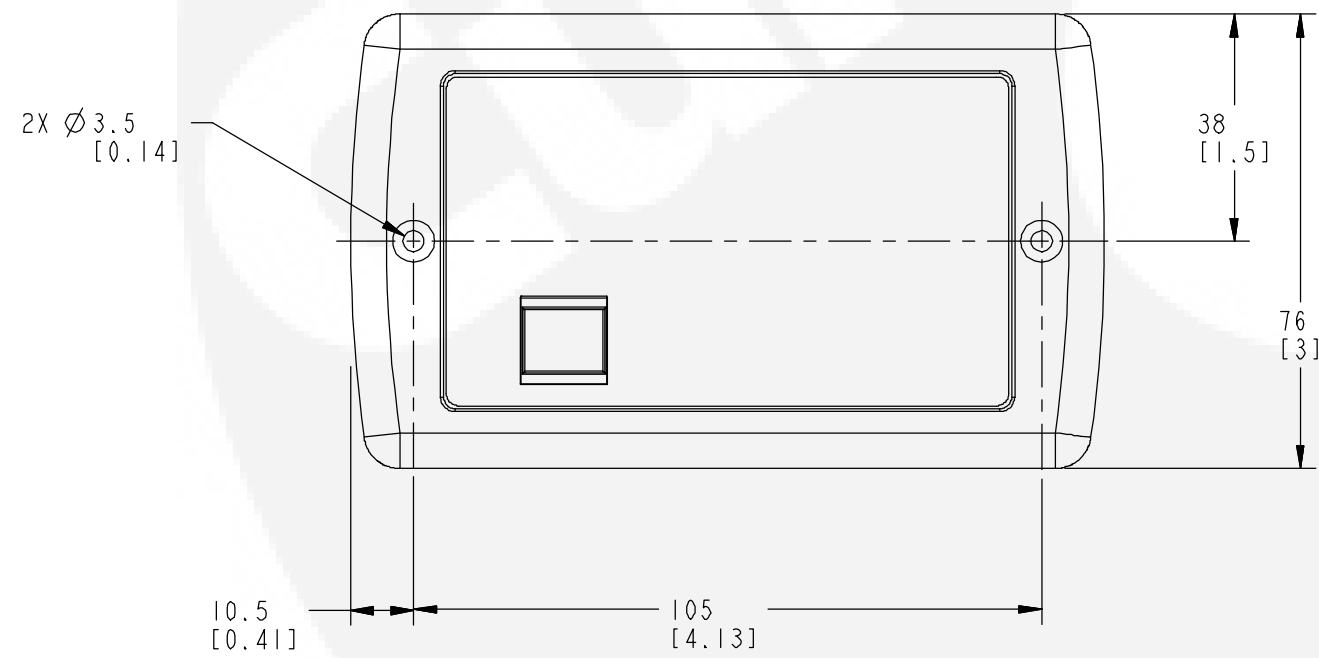
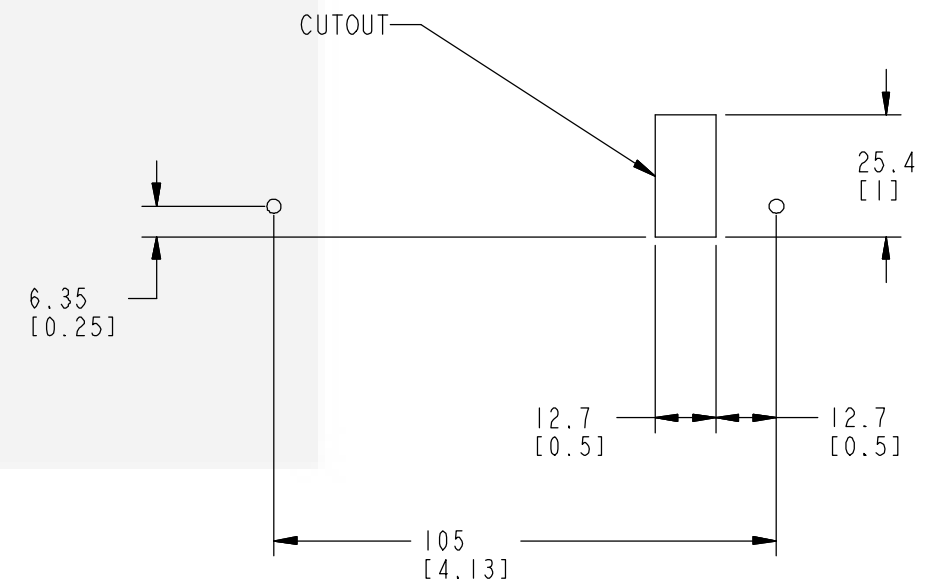
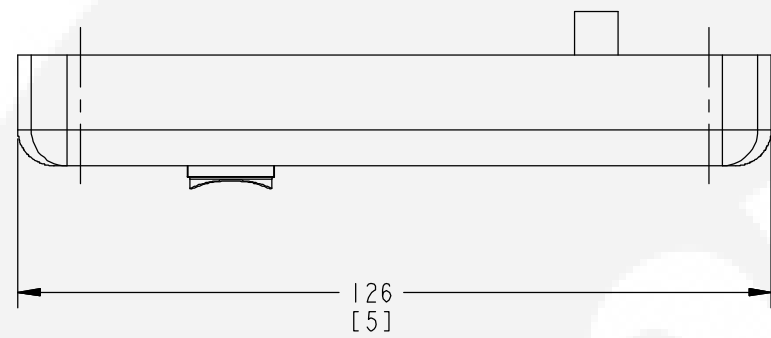

NOTE:
1. PRIMARY DIMENSIONS ARE MILLIMETERS.
DIMENSIONS IN [] ARE INCHES.



Cummins **Onan**

Cummins Power Generation

1400 73rd Ave. NE
Minneapolis, MN 55432 USA

Phone 1 763 574 5000

Toll-free 1 800 888 6626

Fax 1 763 574 5298

Email www.cumminsonan.com/contact

www.cumminsonan.com

Cummins®, Onan®, the "C" logo, and "Performance you rely on." are trademarks of Cummins Inc.

©2014 Cummins Power Generation, Inc. All rights reserved.

