

RV generator set Hybrid Quiet Diesel™ Series HQD 8/10 and 12/18



Cummins Onan

Performance you rely on.™



Features and benefits

- Integrated power system manages battery, generator & shore power together.
- Single control provides simple automatic mode.
- Up to 20% fuel savings.
- Boost mode provides additional motor starting power.
- Significantly reduced noise & vibration.
- High quality, pure sine wave electrical output helps prevent damage to appliances.
- Intelligent transfer switch monitors power quality.
- RV-C connection.

Weight, size and sound level

	8 power unit	12 power unit
Weight:	391 lb (177 kg)	485 lb (220 kg)
Size:	36.6 in x 23.6 in x 22.3 in (929.6 mm x 599.4 mm x 562.4 mm)	41.1 in x 24.5 in x 27 in (1043.9 mm x 622.3 mm x 685.8 mm)
	Transfer switch	Inverter
Weight:	17 lb (8 kg)	55 lb (25 kg)
Size:	12.6 in x 12 in x 4.4 in (320 mm x 304.8 mm x 111.76 mm)	

	Readings at 10 ft (3 m)		
	No load	Half load	Full load
810HQD	56 dB(A)	63 dB(A)	66 dB(A)
1218HQD	59 dB(A)	63 dB(A)	69 dB(A)

Meets National Park Service sound level requirements (60 dB(A) @ 50 ft) for use in national parks.- Typical installation will further reduce sound level.

Models and ratings

Model	Hz	Generator mode watts*	Voltage	Phase	Inverter/boost watts
810HQDSA-6028A	60	7500/10000	120	1	3000/2500
1218HQDSB-6037A	60	12000/18000	120/240	1	6000/6000

* Boost watts added to generator set watts for peak performance. Duration depends on size/status of batteries.

Ambient conditions for rated power output with muffler and RV enclosure, per ISO 8528-1:

- Temperature: 77° F (25° C)
- Altitude: 500 ft (152.4 m), (99 kPa dry)

Typical power output change based on ambient conditions:

- Temperature: Power output decreases 1% for every 10° F (5.5° C) increase
- Altitude: Power output decreases 3.5% for every 1000 ft (305 m) increase

Ratings represent minimums. Actual performance may be significantly higher based on installation and operating conditions.

Standard features

• **Charger:**

- 3-stage charger
- Temperature compensated charging
- Load dependent charge rate
- Equalization
- External high side shunt
- Battery compatibility: Wet cell, gel, agm
- Max battery cable length: 10 ft
- Maximum charger output current: 8/10, 12/18: 280 DC A
- Fuse: Class T 400 A (2 required for 12 and 18)

• **Transfer switch**

- Over voltage protection: 132 V AC
- Under voltage protection: 95 V AC
- Contactors rated at 75 A
- Surge suppression: 1864 Joules, 50 A, 3992 Joules 30 A pass-through
- Fault detection (loss of neutral, loss of ground, reverse polarity)
- Detection time: 500 mS
- Response time: 32 mS
- AC Time delay: 3 seconds
- Ground leakage current: 1 mA
- Power usage: 35 W
- Pass-through relay for non-powered mode
- RV-C port for system information access
- Auto detection of 50 A vs 30 A shore

• **Inverter**

- Pure sine output rating: 8/10 12/18: 6 kV A @ 40° C
- Full load efficiency: 80%
- Minimum battery bank: 8/10, 12/18: 600 A Hrs
- Liquid cooled inverter with heat exchanger inside the power unit

• **Display**

- Two touch auto mode
- Auto start on low battery or air conditioning demand
- Fault display
- Last 15 fault history
- Two quiet time settings
- Shore breaker setting
- Battery status bar
- Battery voltage
- Output current by leg
- AC voltage
- Manual start/stop for all modes
- Built-in clock with 10 year battery
- System setup (battery bank size & type)
- Power unit hour meter

Average fuel consumption:

Diesel - Gal/h (L/h)	No load	Half load	Full load
8PU	0.11 (0.42)	0.48 (1.82)	0.76 (2.88)
12PU	0.5 (1.89)	0.87 (3.29)	1.33 (5.03)

Generator set performance

Voltage regulation: No load to full load: $\pm 3\%$

Frequency regulation: No load to full load: $\pm 0.1\%$

Random frequency variation: Constant load: $\pm 0.5\%$

Air conditioner operation: 8/10 will operate with three 15000 Btu plus a 1500 W base load at 500 Ft. (142.4 m) and 100° F (38° C) 12/18 will operate with four 15000 Btu plus a 4500 W base load at 500 ft. (142.4 m) and 100° F (38° C).

Engine details

Power unit:

USDA approved spark arrestor
Internal radiator
Separate cooling system with pump for inverter
Bulkhead connections for fuel, coolant, & battery
Terminal block for AC connections
Integral muffler
Meets EPA & California emissions standards

8 power unit:

Design: 4-cycle, liquid-cooled diesel engine
Cylinders: 3, In line vertical
Bore: 2.64 in (67 mm)
Stroke: 2.68 in (68 mm)
Displacement: 43.88 in³ (719 cm³)
Compression ratio: 23 to 1
Lube oil capacity: 2.8 qt (2.61 L)
Cooling system capacity: 4 qt (4.2 L)
Power (max) @ 3000 rpm: 12.4 kW (16.6 hp)
Fuel injection pump: Bosch MD type
Combustion chamber: Spherical (TVCS)
Speed range: 1400 - 2600 RPM nominal

12 power unit:

Design: 4-cycle, liquid-cooled diesel engine
Cylinders: 3, In line vertical
Bore: 3.07 in (78 mm)
Stroke: 3.09 in (78.4 mm)
Displacement: 68.53 in³ (1123 cm³)
Compression ratio: 23 to 1
Lube oil capacity: 4 qt (3.8 L)
Cooling system capacity: 6.4 qt (6 L)
Power (max) @ 3000 rpm: 19.4 kW (26.0 hp)
Fuel injection pump: Bosch MD type
Combustion chamber: Spherical (TVCS)
Speed range: 1400 - 2600 RPM nominal

Alternator details

Design: Cummins Onan, permanent magnet
Insulation System: Class H
Exciter System: None
Brushes: None
Bearings: None
Cooling: Main engine fan cooled

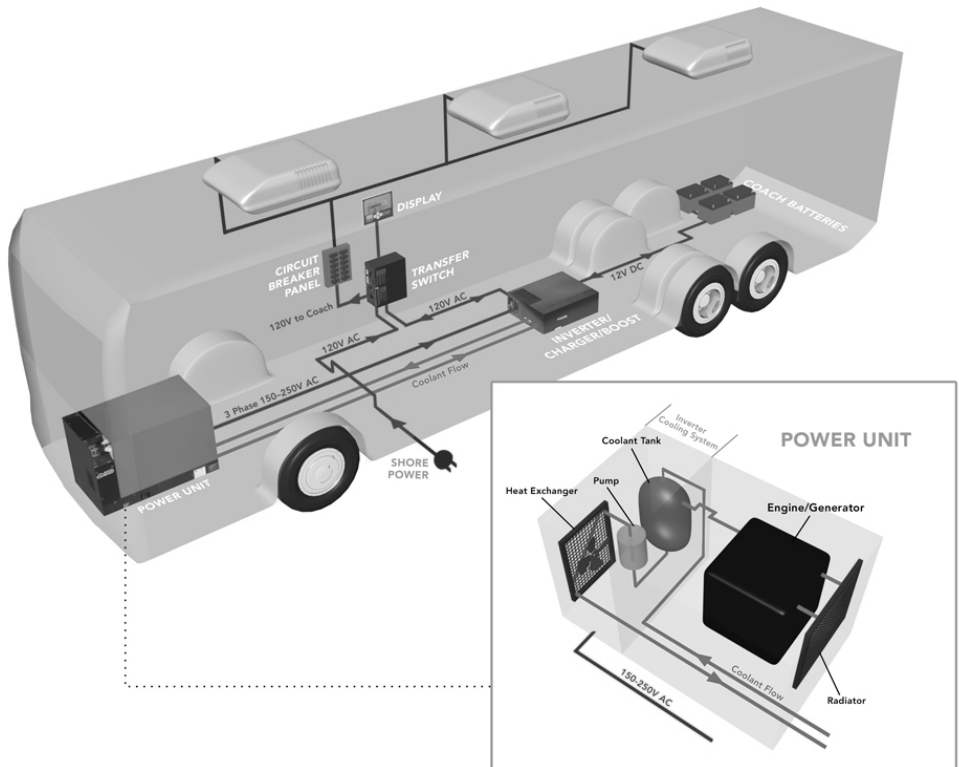

Note: Outline drawings are provided for general reference only and are not intended for design or installation. For more information see your distributor/dealer.

8 power unit

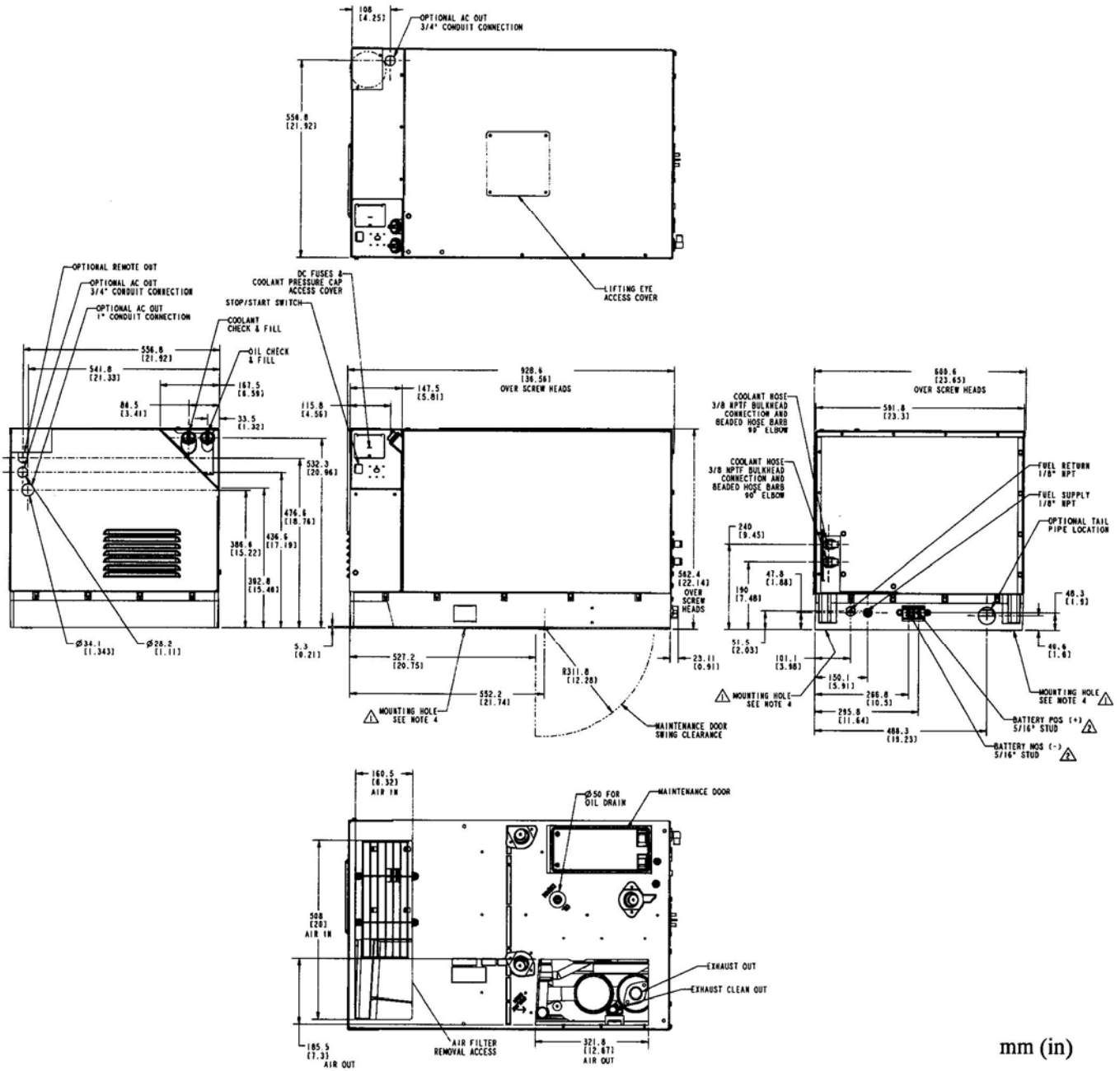

mm (in)

Note: Outline drawings are provided for general reference only and are not intended for design or installation. For more information see your distributor/dealer.

12 power unit

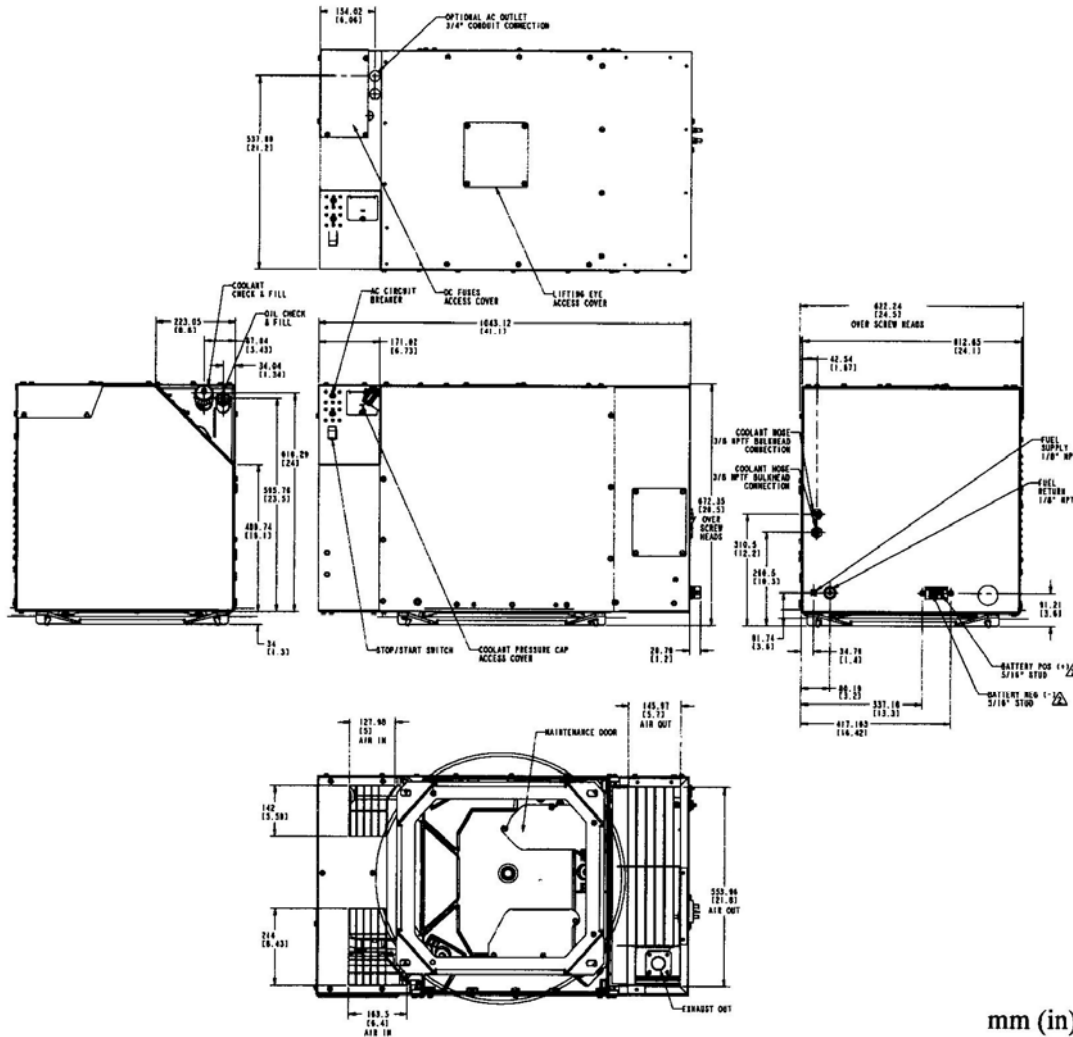

mm (in)

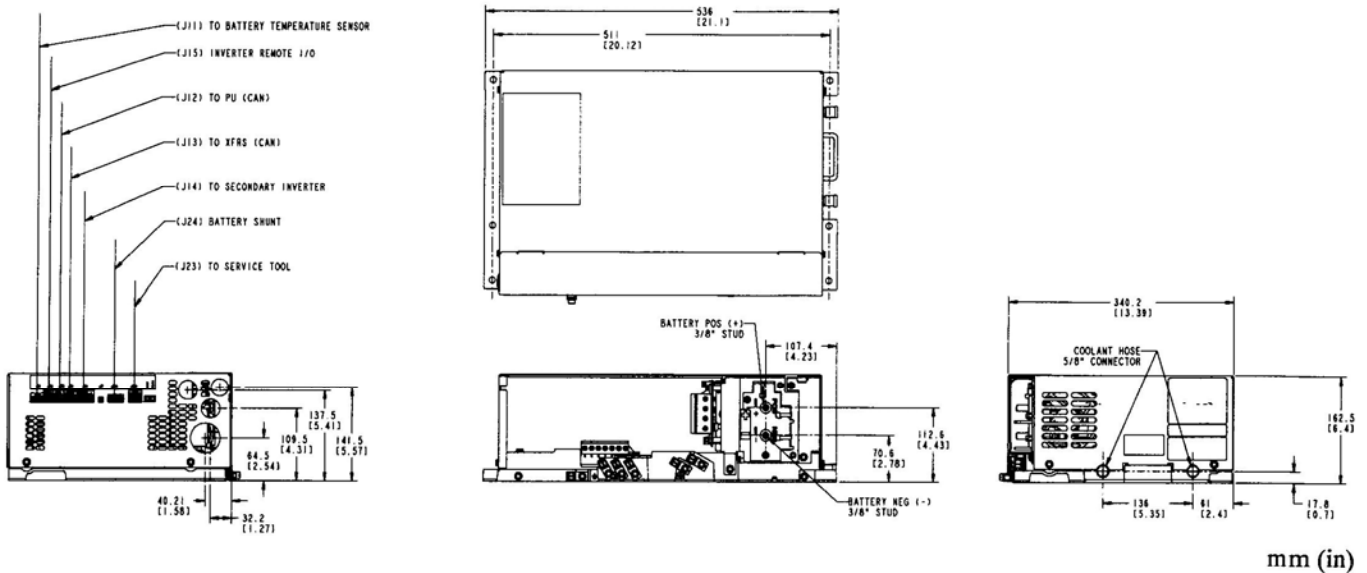

mm (in)

Note: Outline drawings are provided for general reference only and are not intended for design or installation. For more information see your distributor/dealer.

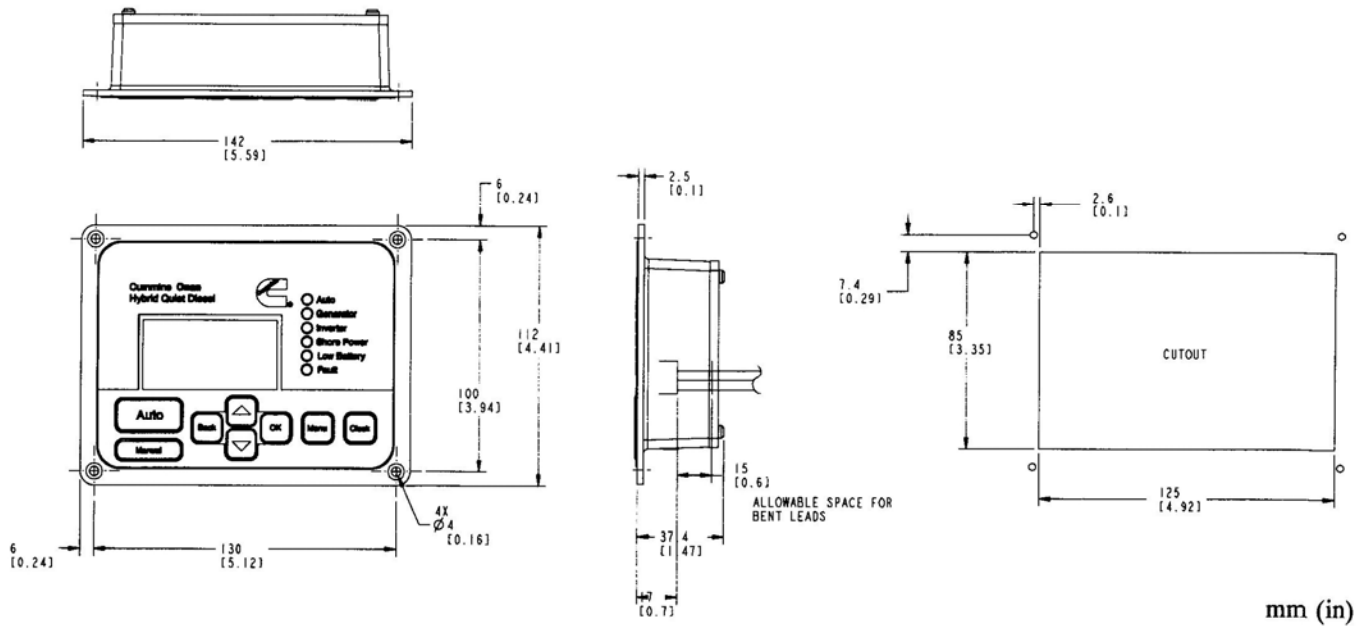
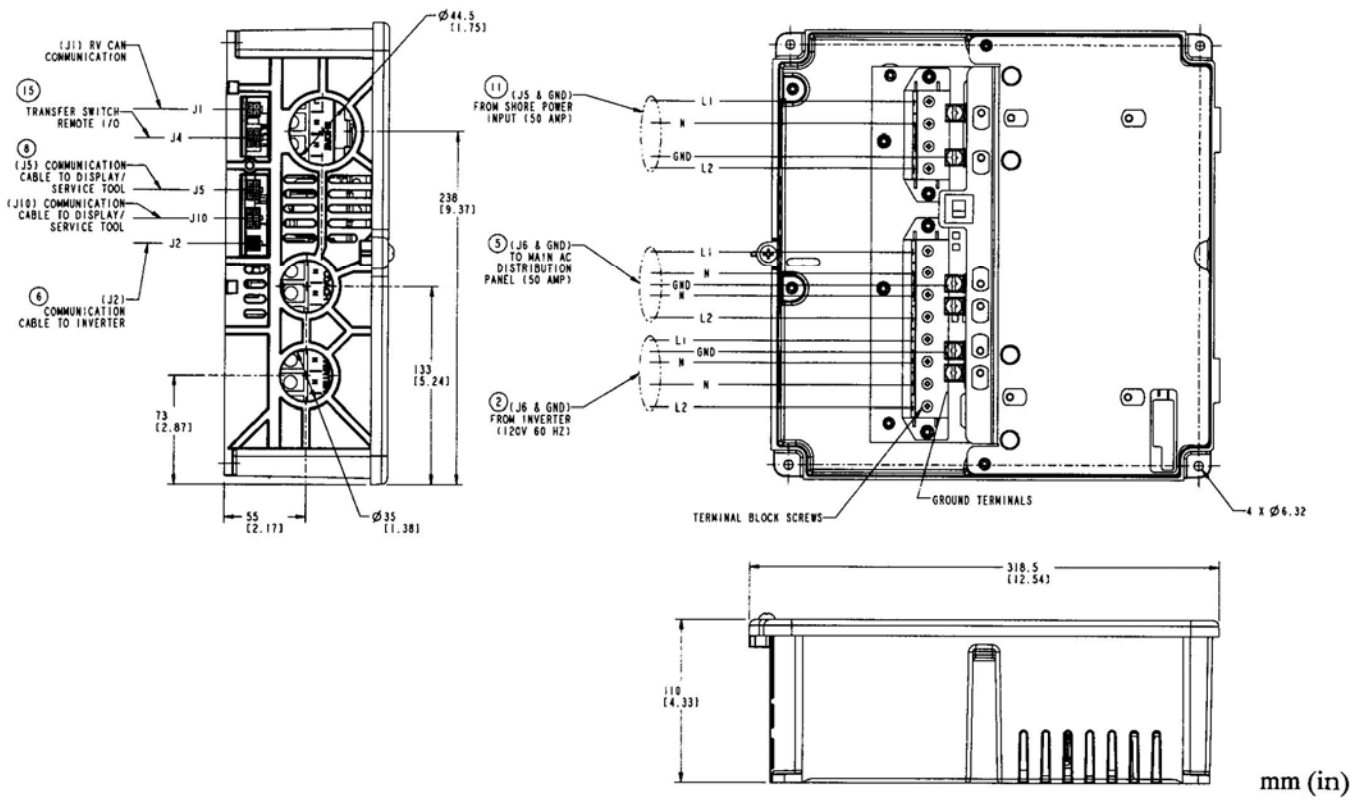

Note: Outline drawings are provided for general reference only and are not intended for design or installation. For more information see your distributor/dealer.

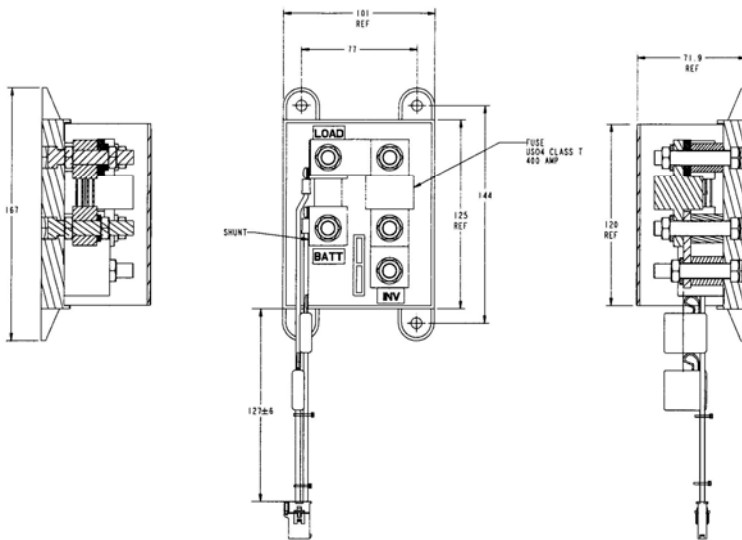

Note: Outline drawings are provided for general reference only and are not intended for design or installation. For more information see your distributor/dealer.

Accessories

- Display (P/N 0541-1333)
- Shunt/fuse kit (P/N 0541-1330)
- Shunt fuse 15 ft cable (P/N 0541-1350)
- Battery save harness 4 pin, 6 in (P/N 0541-1378)
- Transfer switch load demand cable 6 in (P/N 0541-1351)
- Secondary inverter can cable (1215/1218)
 - 3 ft (P/N 0541-1349)
 - 15 ft (P/N 0541-1348)
- Remote wiring harnesses for Display:
 - 25 ft (P/N 0541-0919)
 - 50 ft (P/N 0541-0932)
- Shore fuse box (P/N 699-0132)
- Remote wiring harnesses for Power Unit
 - 30 ft (P/N 0541-1344)
 - 50 ft (P/N 0541-1345)
 - 60 ft (P/N 0541-1427)
- Remote wiring harnesses for Transfer Switch
 - 15 ft (P/N 0541-1346)
 - 30 ft (P/N 0541-1347)

Note: Protected by one or more of the following patents:
 US 5,006,781, US 5,158,208, US 5,096,153, US 5,175,458,
 US 5,240,222, US 5,563,802. Other patents pending.

Testing for RV application

- Tested at extremes of temperature -20° F (-29° C) to 120° F (49° C) for starting and operation
- Tested with RV loads, air conditioners, microwaves, converter, TVs, VCRs
- Tested installed; Cummins owned RVs used for product development testing
- Tested in high humidity conditions
- Tested in salt fog conditions
- Field test program
- This generator set was designed and manufactured in facilities certified to ISO 9001
- 60 Hz models meet applicable U.S. EPA and California emissions standards
- Engine generator, converter/inverter and automatic transfer switch are UL Listed to U.S. and Canadian safety standards.



Warranty policy

This limited warranty covers virtually everything except routine maintenance for the first two years you own your RV generator set, and covers parts and labor on major power train and generator set parts during the third year. Transfer switches and displays are covered for 3 years. In addition, it also includes a free 90-day adjustment policy, which provides that Cummins Inc. will make minor adjustments during the first three months you own it - free of charge! Please note: This 3-year limited warranty applies to RV generator sets used in RV applications only, and does not apply to RV generator sets used in commercial mobile applications.

WARNING:

Do not use this generator set on a boat. Such use may violate U.S. Coast Guard regulations, and can result in severe personal injury or death from fire, explosion, electrocution, or carbon monoxide poisoning.

WARNING:

Back feed to a utility system can cause electrocution and/or property damage. Do not connect to any building electrical except through an approved device or after building main breaker is open.

After sale support

Complete line of parts and accessories

Cummins Inc offers replacement and tune-up parts, accessories, oil and maintenance chemicals - all specially designed to help keep your Cummins Onan generator set running at peak performance. Cummins Inc. also provides genuine Onan Green Label Parts™ that exactly match generator set specifications and will help maximize power output and extend the life of your generator set.



Largest distributor/dealer support network

Cummins Onan generator sets are supported by the largest and best trained worldwide certified distributor/dealer network in the industry. This network of knowledgeable Cummins Onan distributor/dealers will help you select and install the right generator set and accessories to meet the requirements of your specific application. This same network offers a complete selection of commonly used generator set maintenance parts, accessories and products plus manuals and specification sheets. Plus, they can answer your questions regarding proper operation, maintenance schedules and more.

Manuals: Operation and installation manuals ship with the generator set. To obtain additional copies or other manuals for this model, see your Cummins Onan distributor/dealer and request the following manual numbers:

8/10: Operation (981-0178), Installation (981-0645), Service (981-0546), Parts (981-0286)

12/18: Operation (981-0179), Installation (981-0646), Service (981-0546), Parts (981-0283).

To easily locate the nearest Cummins Onan distributor/dealer in your area, or for more information, contact us at 1-800-888-6626 (or 763-574-5000), or visit www.cumminsonan.com.

Contact your distributor/dealer for more information.

Cummins Onan

Cummins Power Generation

1400 73rd Ave. NE
Minneapolis, MN 55432 USA
Phone 1 763 574 5000
Toll-free 1 800 888 6626
Fax 1 763 574 5298
Email www.cumminsonan.com/contact
www.cumminsonan.com

