

Since its introduction to the general public in the late '20s, the Theremin has been evocative in image and tone. Even eyes that had seen such wonders as pictures flying through the air widened at the sight of a musician producing sound using only a conductor's gestures. And its pure tones, able to stand out without distortion against even the full fortissimo of a symphony orchestra, were like nothing anyone had ever heard before.

Was it a hit? You bet, theremin concerts were SRO in halls where audiences were ordinarily sparse. The place of the Theremin in a "modern" orchestra was a given for such maestros as Leopold Stokowski, who used one or more in numerous concerts of the Philadelphia Orchestra during the late '30s. RCA thought that every cultured home would have one, but for a lot of reasons things didn't work out quite like that.

Theremax employs the same heterodyneing principles as the original Theremins and produces the classic sound while adding embellishments made possible by the economy of transistors and Integrated Circuits. It can function as a stand-alone instrument or as a gesture-sensing controller for other musical instruments or in performance art applications.

(c) 1996 PAiA Electronics, Inc.

Portions of this document are excerpted from an article appearing in the Feb 1996 issue of *Electronics Now* magazine, copyright 1996, and are reprinted by permission of the Publisher.

ASSEMBLING THEREMAX

Before beginning assembly, go through the manual. Look at the drawings. Feel the parts. You're naturally eager to plunge right in, but take a few deep breaths first.

Notice that each step in the manual is marked with a checkoff box like this:

DESIGNATION	VALUE	COLOR CODE
() R27	100 ohm	brown-black-brown

Checking off each step as you do it may seem silly and ritualistic, but it greatly decreases the chance of omitting a step and also provides some gratification and reward as each step is completed.

Numbered figures are printed in the Illustrations Supplement in the center of this manual. These pages may be removed for easy reference during assembly.

THE CIRCUIT BOARD

Theremax is built on a single-sided solder masked circuit board. No special preparation or cleaning is necessary before assembly. The "top" of the board is the side that is printed with component designations and parts are mounted from this side. The "bottom" of the board is also called the solder side and is masked with a conformal coating to lessen the chance of solder bridges. Solder pads are tin-lead plated for ease of soldering and assembly.

TOOLS

You'll need a minimum of tools to assemble the kit - a small pair of diagonal wire cutters and pliers, screwdriver, sharp knife, ruler, soldering iron and solder.

Modern electronic components are small (in case you hadn't noticed) and values marked on the part are often difficult to see. Another handy tool for your bench will be a good magnifying glass. Also

use the magnifier to examine each solder joint as it is made to make sure that it doesn't have any of the problems described in the SOLDERING section which follows.

SOLDERING

Select a soldering iron with a small tip and a power rating not more than 35 watts. Soldering guns are completely unacceptable for assembling solid state equipment because the large magnetic field they generate can damage components.

Use only rosin core solder (acid core solder is for plumbing, not electronics work). A proper solder joint has just enough solder to cover the soldering pad and about 1/16-inch of lead passing through it. There are two improper connections to beware of: Using too little solder will sometimes result in a connection which appears to be soldered when actually there is a layer of flux insulating the component lead from the solder bead. This situation can be cured by reheating the joint and applying more solder. If too much solder is used on a joint there is the danger that a conducting bridge of excess solder will flow between adjacent circuit board conductors forming a short circuit. Accidental bridges can be cleaned off by holding the board upside down and flowing the excess solder off onto a clean, hot soldering iron.

Use care when mounting all components. Never force a component into place.

Tips from the Pros: Your first step should always be to check the parts list in this manual (usually the last page). Hard as it is to admit that we make mistakes, it is not unheard of for us to mispack the bag. We ship missing parts *quick*, but there's nothing more aggravating than discovering a missing part in the middle of assembly, at 10:00 PM. Checking the parts also gives you the opportunity to handle them, making sure you know what they are.

Look through the manual fully before you begin assembly, it wouldn't hurt to check the parts supplied against the drawings in the manual. The more you think about what you're going to be doing before you do it, the better.

Since the Tmax case requires some gluing and probably finishing, you may want to get to that part early. Case Assembly begins on page 16.

WIRE JUMPERS

Assembly begins by forming and installing the eight wire jumpers indicated by bold lines on the circuit board parts placement designators and numbered in the illustration to the right. For each jumper, cut a length of the bare wire supplied by measuring it against the distance between the circuit board holes and adding about 1/2". Bend 1/4" of each end down and push through the circuit board holes. Press the jumper fully against the board and solder both ends. Trim off excess wire flush with the solder joint.

() As outlined above, form and install the eight wire jumpers used on the circuit board.

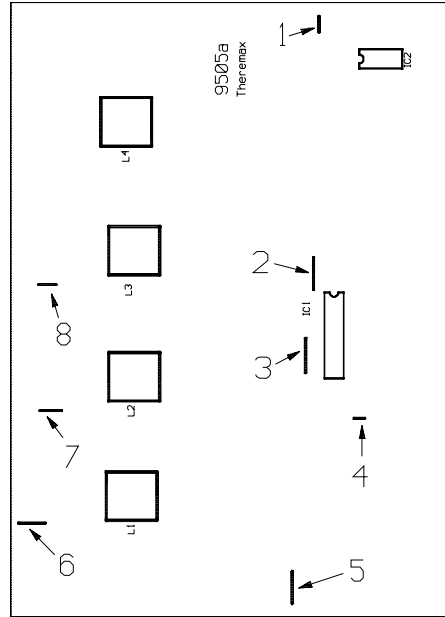

There are eight jumpers on the Theremax circuit board.

RESISTORS

Solder each resistor in place following the parts placement designators printed on the circuit board and the assembly drawing Fig 1. Note that resistors are nonpolarized and may be mounted with either lead in either of the holes in the circuit board. Before mounting each resistor, bend its leads so that they are at a right angle to the body of the part. Put the leads through the holes and then push the resistor firmly into place. Cinch the resistor in place by bending the leads on the solder side of the board out to an angle of about 45 degrees. Solder both ends of each resistor in place as you install it. Clip each lead flush with the solder joint as the joint is made.

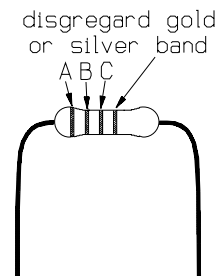

DESIGNATION	VALUE	COLOR CODE A-B-C
() R1	100	brown-black-brown
() R22	1000	brown-black-red
() R23	1000	brown-black-red
() R56	1000	brown-black-red
listed below:	100k	brown-black-yellow
() R71	() R72	() R73 () R74
listed below:	10k	brown-black-orange
() R11	() R16	() R41 () R50
() R70		
() R35	10 megohm	brown-black-blue
() R46	10 megohm	brown-black-blue
() R10	1500 ohm	brown-green-red
() R15	1500 ohm	brown-green-red
() R51	15k	brown-green-orange
() R52	15k	brown-green-orange
listed below	1megohm	brown-black-green
() R24	() R25	() R54 () R57
() R43	2200	red-red-red
() R53	2200	red-red-red
() R42	220k	red-red-yellow
listed below:	22k	red-red-orange
() R39	() R55	() R58 () R64
() R32	330	orange-orange-brown
() R63	330	orange-orange-brown
listed below:	3300	orange-orange-red
() R2	() R7	() R12 () R19
() R31	39k	orange-white-orange
() R62	39k	orange-white-orange
() R44	4.7megohm	yellow-violet-green
listed below:	47	yellow-violet-black
() R5	() R6	() R20 () R21

DESIGNATION	VALUE	COLOR CODE A-B-C
() R28	470	yellow-violet-brown
() R67	470	yellow-violet-brown
() R68	470	yellow-violet-brown
() R26	4700	yellow-violet-red
() R45	4700	yellow-violet-red
() R59	4700	yellow-violet-red
listed below:	470k	yellow-violet-yellow
() R27	() R29	() R40 () R60
listed below:	47k	yellow-violet-orange
() R30	() R33	() R34 () R36
() R37	() R38	() R48 () R49
() R61	() R65	() R66
listed below:	56k	green-blue-orange
() R4	() R9	() R14 () R18
listed below:	680	blue-grey-brown
() R3	() R8	() R13 () R17
() R69		
() R47	68k	blue-grey-orange

OSCILLATOR COILS

The oscillator coils are housed in metal cans to shield them from interaction with one another. Notice that the coils can be mounted only one way, with the case tabs going through the larger holes in the pattern and the solder pins going through the five smaller holes. The solder pins may need to be straightened slightly to align with the holes. Push the part into place until the shoulder of the mounting tab rests on the surface of the circuit board. Solder all five solder pins and also bend the mounting tabs over on the conductors side of the board and solder one of them to the conductor pad.

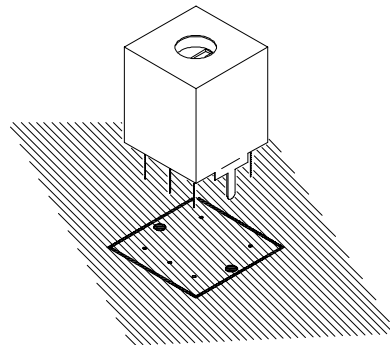

DESIGNATION TYPE

listed below: 796 kHz Oscillator Coils
 () L1 () L2 () L3 () L4
 6 Theremax

CERAMIC DISK AND MYLAR CAPACITORS

Many of the capacitors used in Theremax are nonpolarized Ceramic Disk and Mylar types. For all of these, either lead can go in either of the holes in the circuit board. The leads of the Ceramic Disk and Mylar capacitors are already parallel to each other but still may need to be bent slightly to match the spacing of the circuit board holes. Like the resistors, insert the leads of these parts through the holes in the board and push the part against the circuit board as far as it wants to go. Don't force it, it's OK if it sits a little off the board. Solder each capacitor in place as it is installed and clip the excess leads off flush with the solder joint.

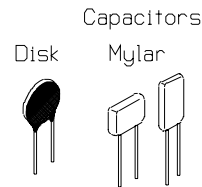

Four of the disk capacitors are temperature stable NPO types. These are separately packed and should be used only where NPO types are specified.

Capacitors are often marked with obscure codes that indicate their values. The 3 digit number that specifies value may be preceded or followed by letters indicating such things as tolerance. If you get confused about which capacitors are which, it may help to group them by same type and check them against quantities on the packing list on the back page of this manual.

Ceramic Disks

DESIGNATION	VALUE	MARKING	
() C40	.001	102	
() C41	.001	102	
listed below:	.01uF	103	
() C2	() C4	() C8	() C12
() C16	() C33	() C43	
listed below:	100pF	101	
() C5	() C9	() C13	() C17
() C39	.0047 uF	472	
() C44	.0047 uF	472	

DESIGNATION	VALUE	MARKING
listed below:	220pF	221
() C22	() C27	() C34
() C37	33pF	33
listed below:	470pF	471
() C7	() C11	() C15 () C19
() C28	() C31	

NPO Ceramic Disks

() C6	100pF NPO	101
() C10	100pF NPO	101
() C14	68pF NPO	68
() C18	68pF NPO	68

Mylar

() C24	.1 uF	104
() C25	.1 uF	104
() C30	.1 uF	104

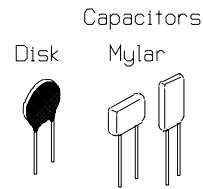

ELECTROLYTIC CAPACITORS

The remaining capacitors used in Theremax are electrolytic types. Unlike the previous components, electrolytic capacitors are polarized and the leads are not interchangeable. Leads are marked "+" and/or "-" and the "+" lead must go through the "+" hole in the circuit board. Frequently the positive lead of the capacitor is significantly longer than the negative lead.

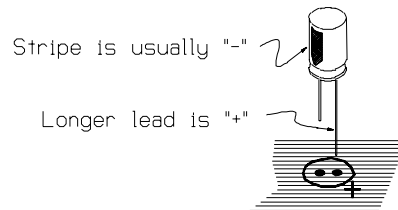

Usually the Negative lead of the capacitor is marked rather than the positive. It naturally goes through the hole not marked "+".

Capacitors supplied with specific kits may have a higher Voltage (V) rating than the minimum specified below.

DESIGNATION	VALUE
() C3	1000uF 10V
() C1	100uF 10V
() C20	100uF 10V
() C42	100uF 10V

DESIGNATION	VALUE		
() C21	10uF 10V		
() C26	10uF 10V		
listed below:	1uF 10V		
() C23	() C32	() C35	() C36
() C38			
() C29	4.7uF 10V		

DIODES

Three types of diodes are used in Theremax, five 1N914 / 4148 silicon signal diodes in small transparent glass cases, one zener diode also in a small transparent case and four 1N34A germanium diodes in slightly larger transparent cases.

When you receive your kit, these parts will be separately packed. Do not remove them from their packing until you're ready to install them; if they get mixed up you will have a hard time sorting them back into types.

Diodes are polarized and must be installed so that the lead on the banded end of the part corresponds to the banded end of the designator on the circuit board. Bend the leads so they are at right angles to the body of the part and insert them through the holes provided in the circuit board.

Diodes are also somewhat heat sensitive so the soldering operation should be done as quickly as possible.

DESIGNATION	TYPE
-------------	------

() D1	8.2V 400 mW. Zener Diode (1N959B)
--------	-----------------------------------

listed below:	1N34A or 1N270 Germanium Diodes		
() D3	() D5	() D7	() D9

1N914 / 1N4148 and zener diodes are in small, transparent cases

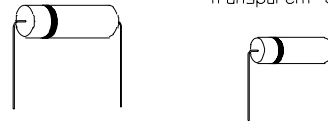

1N34A Germanium diodes are in slightly larger transparent cases

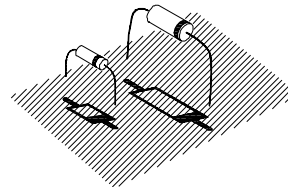

The polarizing color band corresponds to the filled end of the circuit board graphic.

DESIGNATION TYPE

listed below: 1N914 or 1N4148 Silicon Diode
() D10 () D11 () D12 () D13
() D14

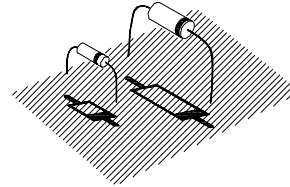

INTEGRATED CIRCUITS

Of all the parts, the ICs are the most easily damaged and should be treated with some respect. In particular, they may be destroyed by discharges of static electricity. Modern ICs are not nearly as sensitive to this kind of damage as were earlier versions, but it is still good practice to handle these parts as little as possible. Also good practice: don't wear nylon during assembly. Don't shuffle around on the carpet immediately before assembly (or if you do, touch a lamp or something to make sure you're discharged). Don't be intimidated. It's rare for parts to be damaged this way.

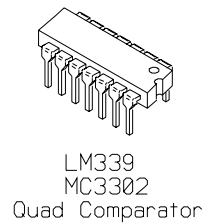

LM339
MC3302
Quad Comparator

ICs are polarized in one or both of two ways; A dot formed into the case of the IC corresponding to pin 1 or a semicircular notch that indicates the end of the package with pin 1. Take care that this polarizing indicator corresponds to the similar indicator on the circuit board graphics.

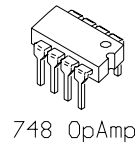

748 OpAmp

The pins of the ICs may be splayed somewhat and not match up exactly with the holes in the circuit board. Carefully re-form the leads if necessary so that they are at right angles to the part. Solder each IC in place as it is installed by initially soldering two pins in diagonal corners of the pattern. Make sure that the part is seated firmly against the pc board by pressing it down while re-melting the solder joint at first one corner, then the other. Finally, solder the remaining connections.

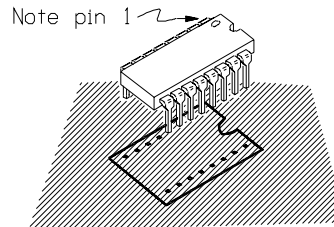

DESIGNATION TYPE

() IC1 LM339 Quad Comparator
() IC2 748 OpAmp

TRANSISTORS

Install the transistors by inserting their three leads through the holes provided for them in the circuit board. Note that the transistors are polarized by the flat side of the case. When the transistors are properly installed this flat will align with the corresponding mark on the circuit board legending. Solder each transistor in place as it is installed and clip the excess leads off flush with the solder joint.

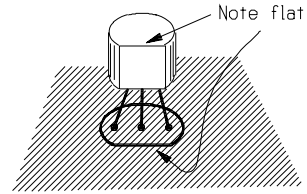

The straight line of the pc graphic symbol corresponds to the flat face of the transistor case.

DESIGNATION TYPE

listed below: 2N4124 NPN Transistor

() Q1 () Q2 () Q3 () Q4
 () Q5 () Q6 () Q7 () Q8
 () Q9 () Q10 () Q11 () Q12

"FLYING WIRES"

(i.e. those which go from circuit board to panel mounted parts.)

In the following steps, wires will be soldered to the circuit board which in later steps will be connected to the Control Panel controls and switches. At each step, cut a piece of wire to the specified length and strip 1/4" of insulation from each end. Twist the exposed wire strands together and "tin" them by melting a small amount of solder into the strands. Solder each connection as it is made and clip any excess wire from the solder side of the board.

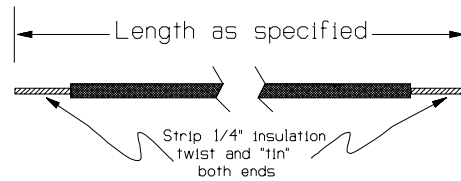

PAD	LENGTH	PAD	LENGTH
() "A"	9-1/2"	() "B"	9-1/2"
() "C"	5"	() "D"	5"
() "E"	9-1/2"	() "F"	10-1/2"
() "G"	10-1/2"	() "H"	12-1/2"
() "J"	9-1/2"	() "K"	9-1/2"
() "L"	11"	() "M"	10-1/2"
() "N"	10-1/2"	() "R"	12-3/4"
() "S"	16"	() "T"	16"
() "+"	12"	() "SG"	5"

SHIELDED CABLE

RG-174/U coaxial cable is used to make shielded connections between the circuit board and the antennae. Make two equal length cable sections by cutting the single piece supplied in half. Prepare the ends of the two pieces as follows:

Strip 1/2" of the outer insulation at each end to expose the braided shield beneath it.

Unbraid the shield by "combing" it with the dull edge of a knife blade or a ball-point pen. This will expose the separately insulated inner conductor.

On one end, trim the braid off flush with the outer insulation. On the other end, pull the strands of shield to one side and twist them together. Tin this pigtail by melting a small amount of solder into it.

On each end, strip about 3/16" of the insulation from the inner conductor and twist and tin the exposed strands.

Using the pieces of co-ax prepared above, solder the inner conductor and shield to the circuit board points listed in the following steps.

WIRE	PC POINT
Cable #1	

() (inner)	"P"
() (shield)	"G1"

Cable #2	
() (inner)	"V"
() (shield)	"G2"

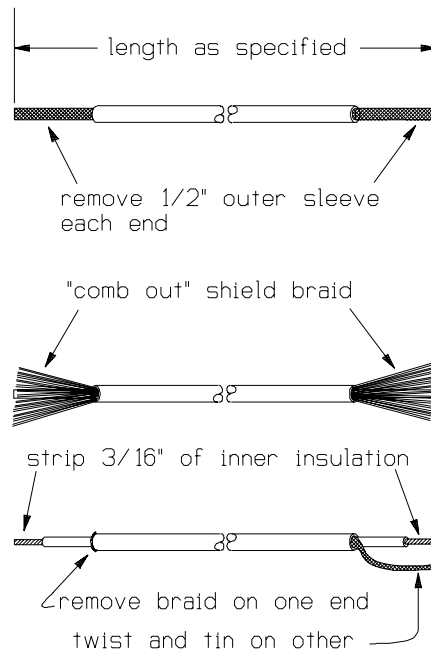

We can now put the circuit board assembly aside while we do some pre-wiring to the Control Panel. This would be a good time to check your work on the circuit board to this point. Make sure polarized components are placed properly and be critical of all your soldering joints.

PANEL CONTROLS

If you have the optional Lectern Case, the controls, jacks and switch mount to its face plate as shown in Fig 2.

- () Using the flat washers and nuts supplied, mount the six potentiometers to the rear of the panel as shown in Fig 2. Note that three different pot values are used. R79 & R80 are 1k (1000 ohm), R81 is 100k (100,000 ohm) and R82, R83 and R84 are 10k (10,000 ohm) units. Orient the controls so the solder lugs are positioned as shown in fig 3 and fully tighten the nuts to secure them.

A Tip: marking the part number (e.g. R79) on the back of the pots with an indelible pen will make later wiring easier and less prone to error.

- () Using the flat washers and nuts provided, mount the miniature toggle switch S1 as shown. Fully tighten the hardware.

- () Using the nuts and washers supplied, mount the six 1/4" Phone Jacks to the Control Panel. Notice that Open Circuit Mono Phone Jacks are used for all except J2, which is a Stereo Jack. Orient the jacks as shown and fully tighten the hardware. You may find it helpful to write the part number under the jack with a marker.

Bend or remove this tab so that the pot will seat flush against the front panel.

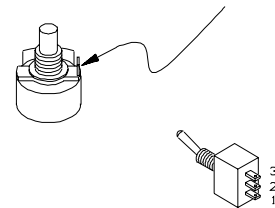

Open Circuit Mono Jack has two solder lugs



Stereo Jack has three solder lugs

Before beginning to wire the panel components it will be helpful to "tin" the lugs of the pots and jacks by melting a small amount of solder onto the lug. Because of the mass of the lugs it will take a lot more heat to melt solder onto them than was required while soldering parts to the circuit board. Melt a little solder onto the tip of your iron and hold it against the lug until the lug is hot enough that solder melts when touched to it. Do not fill in the holes and do not leave large blobs of solder on the lug. This step will make soldering the wires to the lugs in later steps considerably easier.

Now we'll do some preliminary wiring on the Control Panel parts as shown in fig 3. Notice that individual solder lugs are identified by part number and lug designation. For example R79-1 means the lug labeled "1" of the Potentiometer R79. Jack lugs are designated "T" (for the lug which will connect to the tip of an inserted plug) "S", for Sleeve, and "R" for the ring connection of a stereo plug.

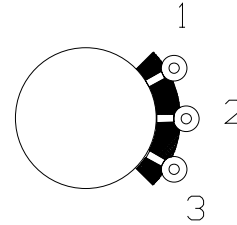

This convention will be followed in these steps: Do not solder a connection to a lug until told to do so with an instruction such as (s2), which means that at that point there will be two wires on the lug in question. If there are not the number of wires specified at the lug when you get ready to solder, recheck to see what has gone wrong. Connections which should not be soldered yet will be marked (ns) for NO SOLDER. On these unsoldered connections simply push the end of the wire through the lug and crimp it back to mechanically secure it.

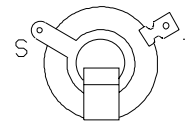

Begin wiring using the single strand bare wire supplied. At each step cut the wire to the specified length. Slip the end through the lug specified so that about 1/8" protrudes through the lug and bend the end of the wire back to mechanically secure it. These wires will all be grounds, so it is OK for them to touch the panel or the bodies of the pots, but do not allow them to touch any solder lugs other than those they are connected to.

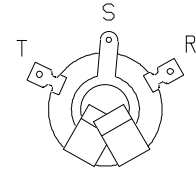

FROM	TO	LENGTH
() R84-1 (ns)	R83-1 (ns)	2-1/2"
() R83-1 (s2)	J1-S (ns)	1-1/2"
() J1-S (ns)	J2-S (ns)	3-3/4"
() J2-S (ns)	J3-S (ns)	2"
() J3-S (ns)	R81-2 (s1)	1-3/4"
() J3-S (s3)	J4-S (ns)	3-1/4"
() J4-S (ns)	R82-1 (s1)	1-3/4"
() J4-S (s3)	J5-S (ns)	3-1/4"

Some connections are made using lengths of the #22 stranded insulated wire. Prepare the wires by cutting them to the length specified, removing 1/4" of insulation from each end and twisting and tinning the exposed wire strands.

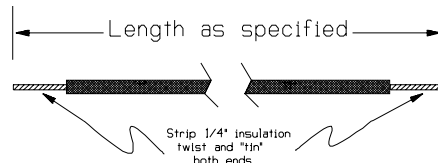

FROM	TO	LENGTH
() R83-2 (s1)	J5-T (ns)	10-3/4"
() R84-2 (s1)	J3-T (ns)	4-1/4"
() R82-2 (s1)	J4-T (s1)	2-3/4"
() R84-1 (s2)	J6-S(s1)	10-1/2"

Four resistors are mounted directly on the solder lugs of the potentiometers and jacks. Install the resistors by pushing their leads through the lugs and "dressing" the part so that its leads do not touch the body of the pots or any lugs to which they do not connect. Cut the leads off so they extend about 1/8" beyond the lug and crimp them to the lug to hold the part in place. Follow the soldering instructions as with the previously installed wiring.

DESIG.	VALUE	COLOR CODE	From	To
() R75	1500 ohms	brown-green-red	J5-S (ns)	R79-1 (ns)
() R76	1500 ohms	brown-green-red	J5-S (s3)	R80-1 (ns)
() R85	270 ohms	red-violet-brown	R79-1 (s2)	R79-3 (ns)
() R86	270 ohms	red-violet-brown	R80-1 (s2)	R80-3 (ns)

The Gate LED (D15) and its associated current limiting resistor R78 wire directly to the solder lugs of J2 as shown in fig 3. Locate the LED and 3900 ohm resistor (orange-white-red). Cut the cathode lead of the LED (closest to the orienting flat on the case) and one lead of the resistor to a length of 1/2". Loosely twist these two leads together and solder as shown.

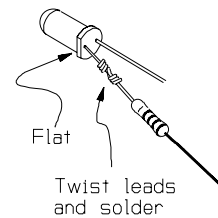

() Push the lens of LED D15 through the hole provided for it in the control panel as shown in fig 3. Connect the free end of R78 to lug "S" of J2 and SOLDER the THREE wires as this lug.

() Connect the anode (free lead) of D15 to lug "T" of J2 but DO NOT SOLDER this connection at this time.

Similarly, the POWER LED (D16) and R77 wire to the lugs of Switch S1. Locate the LED and 2200 ohm resistor (red-red-red). As with D15 above, cut the LED cathode lead and one lead of the resistor short, twist them together and solder.

() Push the lens of LED D16 through the hole provided for it in the control panel as shown in fig 3. Connect the free end of R77 to lug #3 of S1 as shown.
DO NOT SOLDER this connection yet.

() Prepare a 10" length of #22 stranded wire and connect one end to lug #3 of S1. Solder the resistor lead and wire to the lug. If you have difficulty pushing the wire through the hole, you can crimp it around the lug instead. The free end will connect in later steps.

() Connect the anode lead of LED D16 to lug #2 of S1.
DO NOT SOLDER this connection yet.

Theremax wiring continues by connecting the wires previously soldered to the circuit board to the pots and jacks as detailed in fig 4. Notice that previous wiring has been eliminated from this drawing to give a better view of the present operations.

FROM	TO	FROM	TO
() "A"	R79-2 (s1)	() "J"	R83-3 (s1)
() "B"	R79-3 (s2)	() "K"	R84-3 (s1)
() "C"	R80-3 (s2)	() "L"	J3-T (s2)
() "D"	R80-2 (s1)	() "M"	J2-T (s2)
() "E"	R81-3 (s1)	() "N"	J2-R (s1)
() "F"	R81-1 (s1)	() "R"	J1-T (s1)
() "SG"	J1-S (s3)	() "S"	J5-T (s2)
() "H"	R82-3 (s1)	() "T"	J6-T (s1)
		() "+"	S1-2 (s2)

THIS COMPLETES THE ELECTRONIC ASSEMBLY OF THE Theremax.
Before continuing with case assembly take a break then come back and check your work completely. Pay particular attention to the quality of solder connections and orientation of polarized parts.

CASE ASSEMBLY

General details of case assembly and electronic installation are shown in fig 5.

-
- () Begin Case assembly by attaching the end panels to the front and back panels using the eight #6 X 1" Flat Head wood screws provided. The Front Panel is designed to be completely symmetrical and can be mounted with either surface to the front and either edge to the top. The Back panel is not symmetrical and must be mounted with the curved edge up and the curve facing into the box. Use a little wood glue where the front and back panels butt up against the end panels.
 - () Before the glue has had a chance to set, temporarily Install the aluminum bottom plate using ten of the #4 X 3/8" self-tap screws supplied. The bottom will hold the box square while the glue dries, so take particular care that it is square before fastening in place. Notice that the "finished" outside to this part will be covered with a protective vinyl coating that should be stripped away. Drill pilot holes for the screws with a 1/16" bit, or by pressing an awl or icepick into the wood. Be very careful not to strip out the holes for the bottom plate screws. They will be fully tightened later.

Once the glue has fully set, remove the bottom plate and apply a finish to the case. For a pleasing contemporary blond finish, try several coats of Tung Oil. Allow previous coats to be absorbed by the wood fully before applying the next and keep adding coats until there is a pleasing depth to the finish. For a darker case use oak or walnut colored Wood Stain. Usually a single coat will do. For a matte or glossy appearance when using stains, apply the appropriate clear finishing coat. Do not mix Tung Oil and Stain finishes. Allow the finish to dry or set up completely before proceeding.

- () Attach the Control Panel to the rear of the case Front Panel using the remaining six #4 X 3/8" self-tap screws. As with the bottom plate, use a 1/16" drill, awl or icepick to make pilot holes for the screws. Check the alignment of the panel from the front to make sure that it is centered in the opening before securing the screws. (see Fig 5)

Locate the Wall Mount Power Supply (P1). If this part has a connector on the end of its cable, remove and discard it as shown. Notice that one of the two wires will be marked with a colored stripe. A note with the Power Supply will tell whether this stripe marks the (+) or (-) lead.

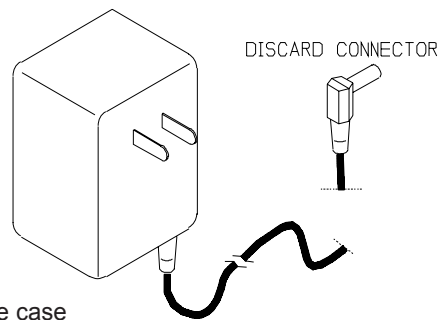

- () Pass the power supply cord from the outside of the case through the hole in the lower edge of the back. Tie a knot in the cord so that about 9" of the cord extends into the case. Separate the two wires from the loose end back to the knot.

- () Strip 1/4" of insulation from the end of the (+) Power Supply wire and twist and tin the exposed wire strands. Connect this wire to lug #1 of Power Switch S1 mounted on the control panel. Solder the single wire at this lug (see fig 4).

- () Attach the Theremax circuit board to the case bottom using the four 4-40 X 1/2" machine screws, #4 X 3/16" rolled aluminum standoffs and nuts supplied as shown in fig 5. Notice the #4 solder lug which is mounted under the nut at the upper right corner of the circuit board, and the orientation of the board (Oscillator coil cans go toward the front of the case).

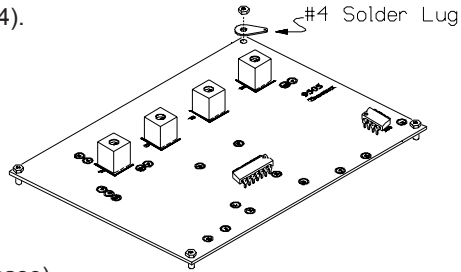

- () Strip 1/4" of insulation from the end of the (-) Power Supply wire and twist and tin the exposed strands. Connect this wire to the solder lug installed on the circuit board above. DO NOT SOLDER this connection.

- () Connect the free end of the wire originating at circuit board point "G" to the solder lug on the circuit board. DO NOT SOLDER.

- () Connect the free end of wire originating at lug #3 of S1 to the solder lug on the circuit board. SOLDER all THREE wires connected to this lug.

- () Re-install the case bottom using the ten #4 X 3/8" self tap screws. Do not overtighten.

- () Install the antennae mounting hardware (8-32 X 1" Flat Head Machine Screw, #10 X 1" OD Flat Washer, #8 Solder Lug and 8-32 Nut) in the holes in the rear of the case as shown in the illustration.

- () Locate the 1,000 uH choke coil (looks like large resistor color code brown-black-red) and cut both leads off to a length of 3/8". Solder one lead of the inductor to the end of the coax coming from point "V" and the other to the soldering lug on the Volume (left) antenna mount. See Illustration.

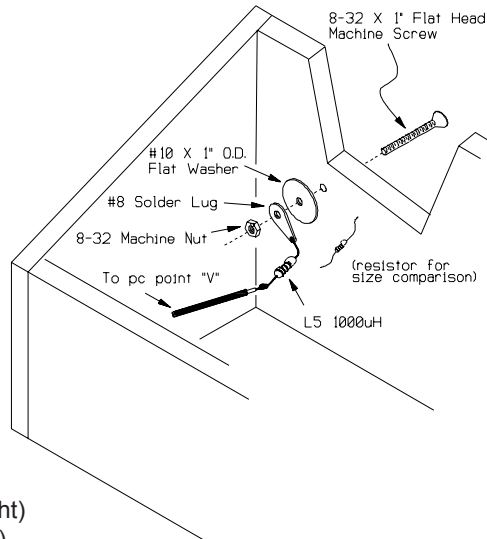

- () Solder the center conductor of the co-ax sections originating at circuit board point "P" directly to the solder lug on the Pitch (right) antenna mount. (see illustration facing page)

-
- () Mount the Pitch and Volume antennae using #10 X 1" OD Flat Washers and #8 Wing Nuts as shown in the illustration. Note that the Vertical Pitch Antenna mounts on the right and the loop-shaped Volume antenna on the left. Each antenna mounts by slipping the end without the mounting loop through the hole in the end panel **from the inside of the case**. The larger curves of the antennae will fit easily through the holes. Place the mounting loop over the 8-32 nut permanently installed on the Machine Screw and tighten in place with the Wing Nut and Flat Washer.

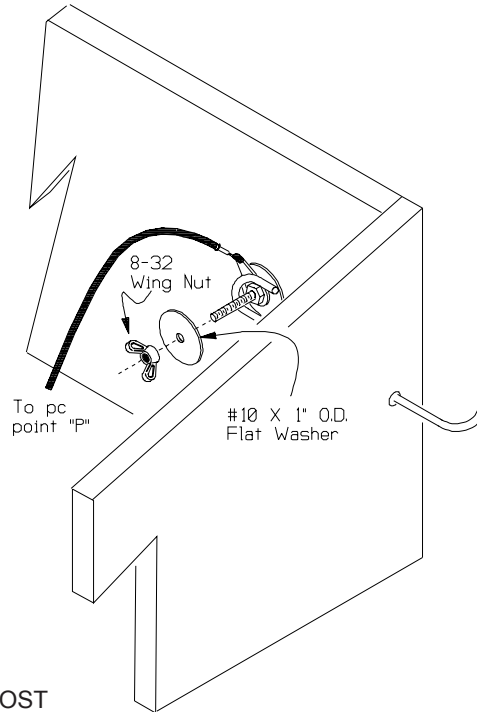

- () Install the knobs. Tighten the set screw slightly and rotate the knob back and forth to see how well it's range of rotation is balanced with the panel graphic. Reorient if not satisfied and fully tighten the set screw when done (not too tight.)

THIS COMPLETES THE ELECTRONIC AND MOST OF THE CASE ASSEMBLY OF THE Theremax. Before plugging the unit in and testing it, take a break then come back and admire your work, it ought to look pretty cool right about now. It wouldn't hurt to check it out one more time, too. The next step is a biggie.

TESTING IT

After rechecking your work, it's time for the all important smoke test. If anything unfortunate is going to happen, this is the most likely time.

Plug the wall-mount transformer into a 120VAC outlet and toggle the POWER Switch to "ON." The LED to the right of the switch should light and if it doesn't, you should immediately unplug the unit from the wall and find out why. The problem could be nothing more than a dead wall outlet. Improperly placed components or solder bridges on the circuit board may be the cause. Check the orientation of the Transistors, Diodes, Integrated Circuits and Electrolytic Capacitors.

When the LED lights, let the unit idle for a few minutes while you check for parts that may be getting hot or any unusual smell, smoke, etc.

Tuning and Testing

First time tuning can be tricky because both the Pitch pair and Volume pair of oscillators must be close to a null in order to hear anything at all. If the Pitch pair are close, but the Volume pair are far apart you won't hear anything because the Volume doesn't come on. If the Volume pair are close but the Pitch pair aren't, you won't hear anything because of no pitch signal. In either case, there's no clear indication of what needs to be adjusted to hear a sound. You can eliminate this complication by temporarily disabling the heterodyne part of the Volume control circuitry and forcing the VCA "on" while the Pitch pair of oscillators is nulled.

Use the clip lead supplied to temporarily connect the V+ line (the banded end of the zener D1) to the "high" side of the volume control (lug 3 of R83). When using this trick, it is very important to set the front panel Volume Control to mid-range or slightly less. The V+ voltage is almost double the normal maximum CV and too high a Control Voltage causes the VCA to saturate and effectively turns it off. If you forget, don't worry, nothing will be damaged by having the Volume set too high, you just won't hear anything until you turn it down.

Set the Pitch Trim and Volume Trim controls on the panel to mid-range and the Pitch CV, Timbre and Velocity controls fully Counter-Clockwise. Turn the slugs of all the coils L1-L4 fully "out" (Counter-Clockwise) just until you feel resistance - the coils can be damaged by applying too much force while turning the slugs. From the fully "out" position, turn the slugs of the two coils L1 and L4 one full turn "in" (CW). These coils will not be adjusted again.

Plug the Tmax output into an amp and turn both on. During initial setup you may need to adjust the volume for comfortable listening levels or to prevent overload and distortion. Make these changes with the amplifier's volume control only. Do not change Tmax's Volume Control from its mid-range setting until told to do so later in these procedures.

Nulling Pitch

Slowly adjust the slug of L2 "in" (Clockwise) while listening for the heterodyne tones that slide down from a very high pitch then go through zero frequency and begin to climb again.. If you have the gain of the amplifier that you're using set high, you may find a couple of places where tones can be heard, but as you adjust the slug continuously from one end to the other you will hear one in particular that is very much louder than the

others. The point at which the frequency of these louder tones go through zero is the ideal setting. But don't confuse this null point with the two super-audio regions when the slug is a little too far "out" or "in".

You won't be able to set exact null by tuning L2 unless it's by random chance. You'll find that the pitch shifts slightly as you remove your hand from tuning the slug, or as you remove the slight downward pressure of the tuning tool. This is OK, the control panel's trim knob is used to set exact null.

When you have gotten close to null using L2, play with the Pitch Trim control on the panel some. You should find that rotating this control has about the same overall effect that turning the tuning slug did, except with much greater resolution and control. Notice particularly that you can easily null the Pitch exactly.

With the pitch nulled, try the antenna response. In a properly operating Tmax you should find that pitch first responds when your hand is about 16 inches from the antenna and that pitch increases smoothly up to a peak when your hand is about 2 inches away.

Calibrating Volume

When you've played with pitch for a while and have a feel for the interaction of the tuning slug and Trim control, it's time to move on to setting up Volume. Leave the Pitch Trim set so that there is some easily audible tone and remove the clip lead from D1 to R83. Turn Tmax's front panel Volume Control all the way to max.

Now slowly adjust the slug of L3 "in" while listening for the output tone. While turning the slug from end to end you will hear the volume rise, then fall back to quiet, then rise again. This corresponds to the way the pitch fell from a high frequency to zero then rose again. When you have observed this, return the slug to it's fully "out" position and once again turn it "in" slowly until the volume starts to increase. The setting of this coil that yields that greatest sensitivity and range of control will be about 1/16 turn short of the first volume peak. At the optimum setting, the max signal level (hand fully removed from antenna) will be about the same as it was when the test jumper was in place.

Try the Volume Antenna response. You should hear the volume begin to decrease as your hand gets closer than about 10" to 12" from the antenna and should be completely off when your hand is closer than about 1/4". Touching the Volume Antenna should not produce any audible artifacts such as chirps or pops. If the range of control seems "com-

pressed" so that all the change in Volume happens over only a few inches of hand motion, try turning L3's slug just slightly CCW, about 1/16 turn. This will produce a slightly lower overall output, which should be compensated by turning up the amplifier's gain control. If you want still more hand motion range, turn the slug out a little more and adjust the amplifier gain accordingly. You will know you have carried things too far when you still hear a tone with your hand on the antenna, but you should find a satisfactory range of control well before that.

With a tone audible, rotate the Timbre control Clockwise and observe that the tone gets considerably more "reed like" as you fade from sine wave to square wave output. Return the Timbre control to it's fully CCW position. Advance the Velocity control fully Clockwise and observe that as your hand is rapidly removed from the Volume antenna the Gate/Trig LED comes on. Also notice that the character of the sound now changes as your hand is withdrawn, getting "fuller" when your hand is moved rapidly and settling to a purer tone when you slow down or stop.

This completes tuning and testing of your Theremax. If any of the setups didn't produce the described result, refer to the Trouble Shooting section on page 5 of the Illustrations Supplement. There is also useful information in the Design Analysis section of this manual.

FINAL CASE ASSEMBLY

The Theremax case top is held in place with the Velcro strips supplied. Use scissors to cut each of the two strips into four equal sized parts as shown. Notice that a velcro fastener has "hook" and "eye" pieces that must be used in matching pairs.

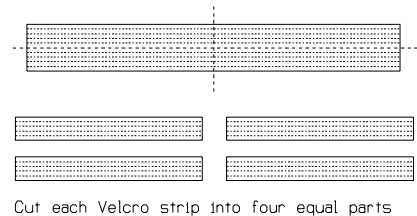

() Remove the protective backing from the four felt-like strips and adhere them to the tops of the case end panels as shown in fig 5.

() Similarly, adhere the "hook" pieces to the underside of the case top as shown. Note the spacing required to make these strips align with the corresponding strips on the case.

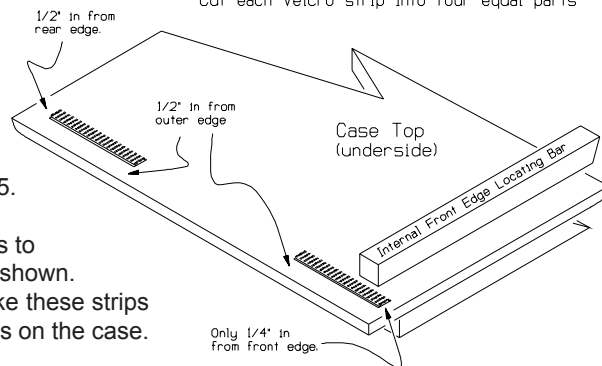

-
- () Attach the self adhesive rubber feet to the case bottom corners by removing the protective backing and sticking them in place.

USING THEREMAX

Playing the theremin is an art that can't be taught in a few paragraphs. Still, plunging ahead where much wiser men fear to tread, here are some observations on the playing style of Clara Rockmore. Clara's background was as a concert violinist, but a palsy in her hands that developed at a young age appeared to have put an end to her career as a performing musician until she started playing the Theremin.

In many pictures of Clara taken over more than a 30 year span she is seen in front of a huge free-standing loudspeaker. This was not just for the theatrical effect of the apparent glory behind her head, though in some of the photos this aspect is quite striking. She positioned the speaker directly behind her so that she could hear the note she was getting ready to play before it was loud enough for the audience to hear, performing pitch corrections in that last split second. Clara developed "aerial fingering" techniques that allowed her to play rapid passages with legato and even staccato articulation.

Reviews and other accounts of performances remark on her motionless, trance-like stance while playing, only her hands dancing back and forth over the antennae. Again a very theatrical presence rooted in necessity. A theremin doesn't respond only to the motion of your hands, it also responds to body motion. If you're moving around while playing it is a lot more difficult to hit an exact pitch. Of course if you're just gliss'ing around, "whoop-ing" it up, so to speak, it doesn't matter that much.

Closing the contacts of a SPST switch plugged into the Mute jack turns the audio output off completely. You may find that a foot switch, either momentary or push-on-off, makes playing easier. This "switch closure" could also be an open collector transistor output from other equipment, such as the "S" triggers used in some synthesizers. Muting the audio has no effect on the Control Voltage outputs, which will function normally even when audio is muted.

Theremax can also be set up in a "Controller Mode" where volume increases as your hand approaches the antenna. For details see page 5 of the Supplement.

Many contemporary electronic musical instruments have provisions for external control of key parameters by means of control voltages, foot pedals and switches and so on, and in many cases Theremax CVs can be directly connected to these inputs. In some cases, instruments expect a variable resistance at their external control jacks and in these cases Theremax CVs can be converted to a resistance using an optocoupler as shown in the illustration. The availability of both gate and open collector switching outputs on the Gate output J2 makes switch style interfacing easy.

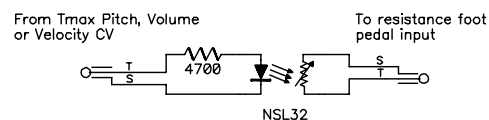
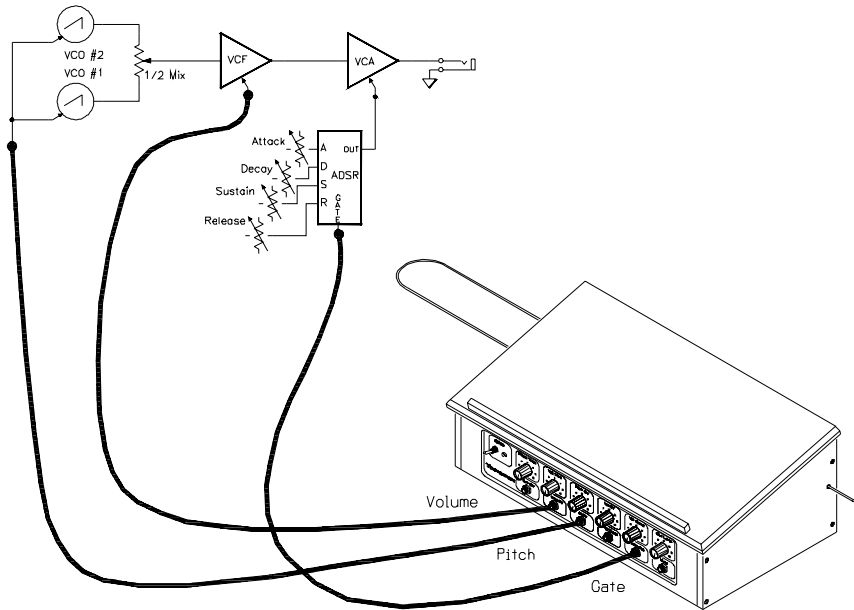

Fig 7. An optocoupler converts Tmax voltages to resistance changes needed by some musical effects control inputs.



In some circles Voltage Controlled analog music synthesizers, antiques that they are, have great cachet . Theremax makes a useful supplemental or alternate controller to the keyboards typically used in these instruments. The figure above shows only one of an unlimited number of possible "patches". The Pitch CV output sets the frequency of the synth's Voltage Controlled Oscillators, so the right hand still controls pitch. VCOs will typically provide a greater selection of waveforms than just sine or square and multiple oscillators will produce a fuller sound.

The Volume CV isn't used to control volume, instead it's routed to the Control Voltage input of the filter, so that the left hand now controls timbre instead.

So if volume is really timbre, how do you control volume? This is the cool part. As with most synthesizer patches, the dynamics of the sound, how fast it builds up and dies away, is controlled by an Envelope Generator, which here is triggered by Theremax's Gate output. The volume hand does still control volume, sort of, but now moving the hand quickly away from the antenna will trigger a sound with dynamics set by the EG. And remember that the place where the hand ends the triggering move sets the timbre (VCF). Air Drums, alright!

And look, Theremax's CVs and Gate don't just respond to the gestures of a performer, they're actually general purpose people sensors and could be used to turn on or brighten lighting instruments arranged to accentuate different parts of a sculpture on the approach of an observer. Or produce kinetic art that responds to how quickly it's approached and how close a person stands.

There are a lot of possibilities.

DESIGN ANALYSIS

The complete Theremax schematic is shown in Fig 6. At the heart of the circuitry are four oscillators, two of which are mixed to produce the pitch signal and two of which are mixed to produce the volume control signal. If it occurs to you that one oscillator could serve as reference for both pitch and volume sensing you have a good designer's instincts, this would be more economical. The difficulty is that multiple oscillators operating at close to the same frequency have a tendency to "pull" and lock to exactly the same frequency, just like the swing of multiple compound pendulums will tend to synchronize. It's not too difficult to minimize this tendency in a single pair of oscillators by physically isolating them from one another, putting guard bands around them on a circuit board and decoupling them from their common power supply, but three oscillators, all heading for essentially the same frequency is considerably more difficult.

If the oscillators lock, there is no more difference frequency so the output goes to zero. It would be bad enough if at the lowest notes the sound suddenly stopped, but the worst part is that prior to locking the oscillators go through an unstable region where the synchronization is chaotic. Instead of just suddenly going quiet, you first hear a burst of noise. These are very unmusical characteristics and having four oscillators allows us to offset the frequency ranges of the pairs so that they do not interact.

The basic oscillator is a classic Hartley type as typified by transistor Q2 and associated circuitry. The primary of Oscillator coil L2 and capacitor C10 form a resonant "tank" circuit load for the transistor, which is configured as a common-base amplifier stage. A tap on the inductor is coupled by C11 to the input of the amplifier (the emitter of Q2) for feedback. Resistors R7 and R10 set the operating point of Q2 to provide the gain necessary to maintain oscillation. R8 and C8 provide decoupling between the power supply and the oscillator to minimize unwanted interactions between the four oscillators. In this oscillator, and the identical one built around Q3, the frequency is set solely by the combination of C10 and the inductance of the primary of L2 and is adjusted by varying the ferrite slug in the oscillator coil.

The sensing oscillators, typified by the one for pitch comprising Q1 and associated components, have a couple of tweaks. The capacitive reactance of the tank has the additional component of the pitch sensing antenna, which is effectively in parallel with capacitor C6. The parasitic capacitance of this antenna is greatly affected by the presence of objects, particularly flesh and blood objects. As an object approaches the antenna, capacitance increases causing the resonant frequency of the circuit to go down.

The sensing oscillator also provides for vernier control of frequency using the potentiometer *R79 which allows a variable setting of the operating point of Q1. Varying the operating point changes frequency by increasing or decreasing the DC current flow through the Primary of L1, which changes the permeability of the core slightly and consequently the reactance of the inductor. The volume sensing oscillator (Q4, etc.) follows this same design.

For both pitch and volume, the outputs of the reference and sensing oscillators are taken off of the secondaries of their respective inductors to buffer them from the effects of loading by the rest of the circuitry. Taking the pitch circuitry as typical, the oscillators are mixed in the modulator consisting of D3 and D5. The output of the modulator consists almost entirely of the sum and difference frequencies with some small leakage at the frequencies of the oscillators. The higher frequencies are rejected by the low pass filter consisting of R26 and C22 and only the audible difference frequency passes. Q8 and associated components comprise a single stage amplifier that boosts the output of the modulator to a more usable level with C27 providing a second pole of filtering for further suppression of the higher frequencies. The comparable circuit elements in the Volume Sensing side of things should be apparent from inspection of the schematic.

Pitch and Volume Control Voltages are each produced in the same way: A comparator converts the sine wave difference frequency to square waves, which are differentiated to a string of pulses, which are then integrated to a control voltage. Taking the Pitch CV as typical, the output of the amplifier Q8 is coupled by C30 to the Schmitt Trigger wired around IC1:A. The inverting input of the comparator is tied to a half-of-supply reference, Vr, that comes from R22 and R23. R38 ties the non-inverting input to Vr and R43 and R44 combine to provide a slight hysteresis that speeds switching and prevents "chattering" when the Schmitt trigger fires.

The output appears across the load resistor R51 and is coupled by C28 to R24 so that the rising edge of the square wave produces a positive-going pulse. On falling edges of the square wave D11 forward biases and quickly charges C28 for the next pulse while also clamping to ground the negative spike that would be produced. As the frequency increases, the constant width pulses come closer together so the equivalent DC value of the pulse train increases. The average value of the pulse train is recovered by charging C24 through D10. The voltage on the capacitor is "read out" by the high impedance emitter follower consisting of Q5 and R82, which is also the panel control that sets the control voltage available at the Pitch CV Jack. The Volume CV is generated in the same way using the comparator built around IC1:b and associated components.

The potentiometer R81 allows either the sine wave at the collector of Q8 or the square wave at the output of the IC1:a or a mix of the two to serve as the audio signal. At the Counterclockwise end of the rotation of this pot, it's grounded wiper shorts out the junction of R40 and R42 allowing only the sine wave to pass to the next stage through C29, R41 and R39. At the other end of it's rotation the wiper shorts out the sine wave and at intermediate settings the two are mixed. C36 couples this audio signal to the Voltage Controlled Amplifier.

In the VCA the gain of a differential pair of transistors (Q10, Q11) is controlled by setting the current flow through them with a third transistor, Q12. The Volume CV, as set by the panel control R83, is converted to a current by R70 and this current sets the collector current of Q12. As this current increases the gains of Q10 and Q11 increase as well. The significant shift in DC voltage at the collectors of these transistors is canceled out in the differential amp built around the 748 opamp IC2. The output of IC2 is coupled by C38 to the audio output Jack J1.

The Volume CV is also used to derive a Velocity Control Voltage. Natural instruments are sensitive to how hard you play them and in this MIDI age this quality has come to be known as Velocity. In Theremax, Velocity is proportional to the rate of increase of Volume, the “velocity” with which your hand is approaching the Volume Antenna. C26 couples changes in the Volume CV through current limiting resistor R28 to the base of the emitter follower Q7. When the Volume CV is decreasing D14 forward biases to clamp the Velocity CV to ground and provide a high current recharge path for C26. Panel mounted pot R84 serves as a load resistor for emitter follower and an attenuator for the CV.

The Velocity CV is available at the front panel Jack J3 and goes a couple of places internally as well. It routes to the base of Q11 in the VCA differential pair where it makes the response non symmetrical, which adds even harmonics to the output to give the sensation of being played hard. The Velocity CV also is routed to the Schmitt trigger consisting of IC1:c and associated components, when velocity exceeds a threshold the Schmitt changes state to provide a triggering pulse to external equipment. Since many vintage analog synths use a switch closure to ground (what is known as “S” trigger) to initiate a musical event, the final comparator in IC1 is used as an open collector to ground turned on by the Gate. Both of these signals appear at the Stereo Phone jack J2 with the gate connected to the tip and the open collector to the ring. A mono plug may be used to access the Gate since the open collector tied to the ring can be grounded with no problem.

D1, the 8.2V zener stabilizes the voltage from the wall wart power supply so that power line transients and sags don't produce pitch glitches. Finally, the funny wiring on the power switch? That's just so the “spare” lug can be used as a ground and provide mechanical support for the Resistor and LED.

Theremax Parts List

Quan	Desc	Designation
Capacitors		
<i>Ceramic disk</i>		
2	.001uF	C40,C41
2	.0047uF	C39,C44
7	.01uF	C2,C4,C8,C12, C16,C33,C43
4	100pF	C5,C9,C13,C17
3	220pF	C22,C27,C34
1	33pF	C37
6	470pF	C7,C11,C15,C19, C28,C31
2	100pF NPO	C6,C10
2	68pF NPO	C14,C18
<i>Mylar</i>		
3	.1 uF	C24,C25,C30
<i>Electrolytic</i>		
1	1000uF 10V	C3
3	100uF 10V	C1,C20,C42
2	10uF 10V	C21,C26
5	1uF 10V	C23,C32,C35,C36,C38
1	4.7uF 10V	C29

1/4W. 5% Resistors all values in ohms

1	100	brown-black-brown	R1
3	1000	brown-black-red	R22,R23,R56
4	100k	brown-black-yellow	R71,R72,R73,R74
5	10k	brown-black-orange	R11,R16,R41,R50,R70
2	10 meg	brown-black-blue	R35,R46
4	1500	brown-green-red	R10,R15,*R75,*R76
2	15k	brown-green-orange	R51,R52
4	1 meg	brown-black-green	R24,R25,R54,R57
3	2200	red-red-red	R43,R53,*R77
1	220k	red-red-yellow	R42
4	22k	red-red-orange	R39,R55,R58,R64
2	270	red-violet-brown	*R85,*R86
2	330	orange-orange-brown	R32,R63
4	3300	orange-orange-red	R2,R7,R12,R19
1	3900	orange-white-red	*R78
2	39k	orange-white-orange	R31,R62
1	4.7 meg	yellow-violet-green	R44
4	47	yellow-violet-black	R5,R6,R20,R21
3	470	yellow-violet-brown	R28,R67,R68
3	4700	yellow-violet-red	R26,R45,R59
4	470k	yellow-violet-yellow	R27,R29,R40,R60
11	47k	yellow-violet-orange	R30,R33,R34,R36,R37, R38,R48,R49,R61,R65, R66
4	56k	green-blue-orange	R4,R9,R14,R18
5	680	blue-grey-brown	R3,R8,R13,R17,R69
1	68k	blue-grey-orange	R47

Semiconductors

1	8.2V 400 mW. Zener Diode	D1
4	1N34A or 1N270 Ge Diode	D3,D5,D7,D9
5	1N914 / 4148 Si Diode	D10-D14
2	Red LED	*D15,*D16
1	LM339 Quad Comparator	IC1
1	748 OpAmp	IC2
12	2N4124 NPN Transistor	Q1-Q12
Panel Mount Potentiometers (with hardware)		
2	1000 ohm Potentiometer	*R79,*R80
3	10k ohm Potentiometer	*R82,*R83,*R84
1	100k ohm Potentiometer	*R81
Miscellaneous		
5	1/4" O.C. Phone Jack	*J1,*J3,*J4,*J5,*J6
1	1/4" Stereo Phone Jack	*J2
1	SPDT Switch	*S1
1	12 VDC Wall Wart	*P1
4	796 kHz. (nom.) Osc. Coil	L1,L2,L3,L4
1	1000 uH Choke Coil	*L5
1	Clip Lead	
20	inches RG-174/U co-ax	
27	inches bare wire	
21	ft. #22 stranded	
6	Set Screw Knobs	
1	Instruction Manual	
1	9505 Circuit Board	

Theremax Lectern Case

Quan	description
1	set Wooden Case parts (ends, front, back, top)
8	#6 X 1" Flat Head Wood Screws
1	set Aluminum parts (bottom, control panel)
16	#4 X 3/8 Self Tap Screws
2	8-32 X 1" Flat Head Machine Screw
2	#8 - 32 Machine Nut
4	#10 X 1" OD Flat Washer
2	8-32 Wing Nuts
2	#8 Solder Lugs
4	#4 X 3/16" Aluminum Standoffs
4	4-40 X 1/2" Machine Screws
4	4-40 nuts
1	#4 Solder Lug
4	Stick-on Rubber Feet
1	Pitch Antenna
1	Volume Antenna
1	Strip Velcro hook and loop