



Nakamichi

TA-4 / TA-3 / TA-2

High Definition Tuner Amplifier

Owner's Manual

Bedienungsanleitung

Mode d'emploi

This Owner's Manual covers the following models:
Diese Bedienungsanleitung gilt für die folgenden Modelle:
Ce mode d'emploi couvre les modèles suivants:

TA-4	TA-4A	TA-4E
TA-3	TA-3A	TA-3E
TA-2	TA-2A	TA-2E



English from page 4

Deutsch von Seite 24

Français voir page 44

Congratulations!

You have chosen a truly exceptional product. All Nakamichi audio components are created according to a simple but highly demanding philosophy: perfectly natural reproduction of the musical experience, without the slightest trace of coloration. Even the ambience of the stage and the heartbeat of the performers can be felt when hearing music reproduced the Nakamichi way. This is what has earned our products a dedicated following among discerning audio enthusiasts, music lovers and musicians the world over.

The TA-4/TA-3/TA-2 are High Definition Tuner Amplifiers which bring utterly pure sound within easy reach. In the power amplifier section, the extraordinary STASIS circuit topology combined with high current capability results in ample output power and excellent speaker drive characteristics. The preamplifier features Nakamichi's innovative Isolated Ground principle for complete freedom from interference between various circuit stages. The high-precision PLL synthesizer tuner with 10 AM/FM presets boasts solid performance and lets you enjoy broadcasts in impeccable quality.

Equally impressive as the performance of these tuner amplifiers is their ease of operation. The supplied remote control lets you operate an entire system of Nakamichi components, and provisions for audiovisual components further enhance system expansion possibilities.

In order to take full advantage of this unit's superior performance, please read this manual in its entirety and retain it for future reference.

*Thank you.
Nakamichi Corporation*

The photo on this page shows the concert hall in the Nakamichi Research Institute. Here every component must prove itself, above and beyond technical specifications. This hall helps us explore the realm of live music, which is the starting and end point in the development of all Nakamichi products.

Lieber Stereofreund!

Sie haben sich für ein in jeder Hinsicht hervorragendes Gerät entschieden. Alle Audio-Komponenten von Nakamichi folgen einem ebenso einfachen wie strikten Motto: absolut natürliche Musikwiedergabe, ohne jeden Anflug von Verfärbungen. Musik hören mit Nakamichi ist ein Erlebnis, das selbst die Raumdimension und die elektrisierende Atmosphäre auf der Bühne mit einschließt. Nicht umsonst genießt der Name Nakamichi bei Musikfreunden, HiFi-Liebhabern und Musikern auf der ganzen Welt einen so guten Ruf.

Die Modelle TA-4/TA-3/TA-2 sind Tuner-Verstärker, die es einfach machen, hervorragende Wiedergabequalität und Klangtreue zu genießen. Das Endverstärkerteil arbeitet nach dem überragenden STASIS-Prinzip, das zusammen mit der Kapazität für hohe Stromabgabe enorme Ausgangsleistung und hervorragende Lautsprecheransteuerung garantiert. Im Vorverstärker verhindert Nakamichis "Isolated Ground" — Technik durch getrennte Massekreise gegenseitige Störeinflüsse zwischen den Schaltungsstufen. Der hochpräzise PLL-Synthesizer-Tuner mit 10 Stationstasten für UKW und MW bringt Rundfunksendungen in bester Qualität zu Gehör.

Genauso beeindruckend wie die technische Leistung dieser Geräte ist auch ihre Bedienungsfreundlichkeit. Eine mitgelieferte Fernbedienung erlaubt die Steuerung einer ganzen Nakamichi-Anlage, und Anschlüsse für A/V-Geräte bieten interessante Möglichkeiten zur Systemerweiterung.

Um die vorzügliche Leistung dieses Geräts voll zu nutzen, raten wir Ihnen, die Bedienungsanleitung vor Inbetriebnahme genau durchzulesen und für späteres Nachschlagen gut aufzubewahren.

*Vielen Dank.
Nakamichi Corporation*

Das Foto auf dieser Seite zeigt die Konzerthalle im Nakamichi-Forschungszentrum. Über die rein technische Seite hinaus gewinnen wir dort wichtige Impulse für unsere Arbeit. Jedes Gerät muß hier beweisen, was in ihm steckt, und live erlebte Musik steht am Anfang und Ende aller Entwicklungsarbeit.

Cher Client

Vous venez d'acquiescer un produit réellement exceptionnel. Tous les éléments des chaînes Nakamichi sont conçus selon un principe simple mais des plus exigeants, à savoir: une reproduction parfaitement naturelle, exempte de la moindre coloration. Quand une musique est reproduite par Nakamichi, c'est toute l'ambiance du plateau que l'on ressent, jusqu'aux battements de coeur des musiciens. De nous être tenus à ce principe nous a valu des adeptes fidèles parmi les audiophiles, les mélomanes et les musiciens du monde entier.

Les modèles TA-4/TA-3/TA-2 représentent des amplificateurs tuner de haute définition qui offrent un son très pur à une portée raisonnable. Dans la section de l'amplificateur de puissance, la topologie du circuit STASIS extraordinaire combinée à une capacité haute de courant résulte en des caractéristiques de puissance de sortie élevée et de commande excellente des haut-parleurs. Le préamplificateur présente le principe de mise à la terre isolée innovateur de Nakamichi, pour une entière élimination de l'interférence entre les diverses étapes de circuit. Le tuner synthétiseur PLL de haute précision avec 10 préréglages AM/FM offre une grande performance et vous permet de tirer le maximum de plaisir des émissions de parfaite qualité.

La facilité de fonctionnement de ces amplificateurs tuners est aussi impressionnante que leur performance. La télécommande fournie vous permet d'opérer un système complet de composants Nakamichi, et des particularités pour les composants audiovisuels améliorent davantage les possibilités d'extension du système.

Afin de profiter pleinement des performances supérieures de cet appareil, nous vous conseillons vivement de lire d'abord ce mode d'emploi d'un bout à l'autre et de le conserver pour pouvoir vous y référer plus tard.

*Merci.
Nakamichi Corporation*

La photo ci-dessus est une vue de la salle de concert qui se trouve dans l'institut de recherches de Nakamichi. Cette salle sert à "mesurer" les sensations qui, par définition même, sont immensurables et se situent au-delà des spécifications techniques. C'est dans ce royaume de la musique vivante que commence et qu'aboutit la création de tous les produits Nakamichi.



CAUTION

TO REDUCE THE RISK OF ELECTRIC SHOCK, DO NOT REMOVE COVER (OR BACK). NO USER-SERVICEABLE PARTS INSIDE. REFER SERVICING TO QUALIFIED SERVICE PERSONNEL.

The lightning flash with arrowhead symbol, within an equilateral triangle, is intended to alert the user of the presence of uninsulated "dangerous voltage" within the product's enclosure; that may be of sufficient magnitude to constitute a risk of electric shock to persons.

The exclamation point within an equilateral triangle is intended to alert the user of the presence of important operating and maintenance (servicing) instructions, in the literature accompanying the appliance.

WARNING

TO PREVENT FIRE OR SHOCK HAZARD, DO NOT EXPOSE THIS APPLIANCE TO RAIN OR MOISTURE.

This equipment generates and uses radio frequency energy and if not installed and used properly, that is, in strict accordance with the manufacturer's instructions, may cause interference to radio and television reception. It has been type tested and found to comply with the limits for a Class B computing device in accordance with the specifications in Subpart J of Part 15 of FCC Rules, which are designed to provide reasonable protection against such interference in a residential installation. However, there is no guarantee that interference will not occur in a particular installation. If this equipment does cause interference to radio or television reception, which can be determined by tuning the equipment off and on, the user is encouraged to try to correct the interference by one or more of the following measures:

- reorient the receiving antenna
- relocate this equipment with respect to the receiver

- move this equipment away from the receiver
- plug this equipment into a different outlet so that equipment and receiver are on different branch circuits.

If necessary, the user should consult the dealer or an experienced radio/television technician for additional suggestions. The user may find the following booklet prepared by the Federal Communications Commission helpful:

"How to Identify and Resolve Radio-TV Interference Problems".

This booklet is available from the U.S. Government Printing Office, Washington, DC 20402, Stock No. 004-000-00345-4.

Nakamichi Corporation Certifies That This Equipment Conforms to DHHS Regulations No. 21 CFR, Chapter 1, Subchapter J.

Please record the Model Number and Serial Number in the space provided below and retain these numbers.

Model Number and Serial Number are located on the rear panel of the unit.

Model Number: TA-4/TA-3/TA-2
 TA-4A/TA-3A/TA-2A
 TA-4E/TA-3E/TA-2E

Serial Number: _____

CONTENTS

Safety Instructions.....	4
Controls and Functions	6
Connections	10
Operation.....	15
Troubleshooting	21
Specifications	22

Nakamichi high-fidelity equipment is sold in more than 50 countries around the world. Many of these countries have strict safety regulations to which Nakamichi products must comply.

Models designated by an "A" have been produced for North America (USA and Canada) and comply with the requirements of Underwriters Laboratories (UL) and/or Canadian Stan-

dards Association (CSA) as well as with other applicable state/provincial and federal safety standards.

Models designated by an "E" have been produced for Europe and comply with the requirements of EEC Recommendation 82/499 as well as with other applicable European safety standards.

Models without an "A" or "E" have been produced for countries other than North America, Europe and Japan and comply with applicable safety standards.

Nakamichi has authorized its local distributors to offer warranties only on products which have been produced in accordance with the foregoing standards.

Safety Instructions

The following safety instructions have been included in compliance with safety standard regulations. Please read them carefully.

1. Read Instructions—All the safety and operating instructions should be read before the appliance is operated.
2. Retain instructions—The safety and operating instructions should be retained for future reference.
3. Heed Warnings—Adhere to all warnings on the appliance and in the operating instructions.
4. Follow Instructions—All operating and use instructions should be followed.
5. Water and Moisture—The appliance should not be used near water—for example, near a bathtub, washbowl, kitchen sink, laundry tub, in a wet basement, or near a swimming pool, etc.
6. Carts and Stands—The appliance should be used only with a cart or stand that is recommended by the manufacturer.
7. An appliance and cart combination should be moved with care. Quick stops, excessive force, and uneven surfaces may cause the appliance and cart combination to overturn. 
8. Wall or Ceiling Mounting—The appliance should be mounted to a wall or ceiling only as recommended by the manufacturer.
9. Ventilation—The appliance should be situated so that its location or position does not interfere with its proper ventilation. For example, the appliance should not be situated on a bed, sofa, rug or similar surface that may block the ventilation openings; or placed in a built-in installation, such as a bookcase or cabinet that may impede the flow of air through the ventilation openings.

10. Heat—The appliance should be situated away from heat sources such as radiators, heat registers, stoves, or other appliances (including amplifiers) which produce heat.
11. Power Sources—The appliance should be connected to a power supply only of the type described in the operating instructions or as marked on the appliance.
12. Grounding or Polarization—Precautions should be taken so that the grounding or polarization means of an appliance is not defeated.
13. Power-Cord Protection—Power-supply cords should be routed so that they are not likely to be walked on or pinched by items placed upon or against them, paying particular attention to cords at plugs, convenience receptacles, and the point where they exit from the appliance.
14. Cleaning—The appliance should be cleaned only as recommended by the manufacturer.
15. Power Lines—An outdoor antenna should be located away from power lines.
16. Outdoor Antenna Grounding—If an outside antenna is connected to the receiver, be sure the antenna system is grounded so as to provide some protection against voltage surges and built up static charges. Section 810 of the

National electrical Code, ANSI/NFPA No 70—1984, provides information with respect to proper grounding of the mast and supporting structure, grounding of the lead-in wire to an antenna discharge unit, size of grounding conductors, location of antenna-discharge unit, connection to grounding electrodes, and requirements for the grounding electrode. See below.

17. Nonuse Periods—The power cord of the appliance should be unplugged from the outlet when left unused for a long period of time.
18. Object and Liquid Entry—Care should be taken so that objects do not fall and liquids are not spilled into the enclosure through openings.
19. Damage Requiring Service—The appliance should be serviced by qualified service personnel when:
 - A. The power-supply cord or the plug has been damaged; or,
 - B. Objects have fallen, or liquid has been spilled into the appliance; or,
 - C. The appliance has been exposed to rain; or,
 - D. The appliance does not appear to operate normally or exhibits a marked change in performance; or,

E. The appliance has been dropped, or the enclosure damaged.

- 20 Servicing—The user should not attempt to service the appliance beyond that described in the operating instruction. All other servicing should be referred to qualified service personnel.

Caring for the Exterior Panels

Caring for the exterior panels of this unit should be limited to wiping with a soft dry cloth. Avoid using solvents or alcohol-based cleaners.

“Note to CATV system installer:

This reminder is provided to call the CATV system installer’s attention to Article 820-22 of the NEC that provides guidelines for proper grounding and, in particular, specifies that the cable ground shall be connected to the grounding system of the building, as close to the point of cable entry as practical”.

EXAMPLE OF ANTENNA GROUNDING ACCORDING TO NATIONAL ELECTRICAL CODE INSTRUCTIONS

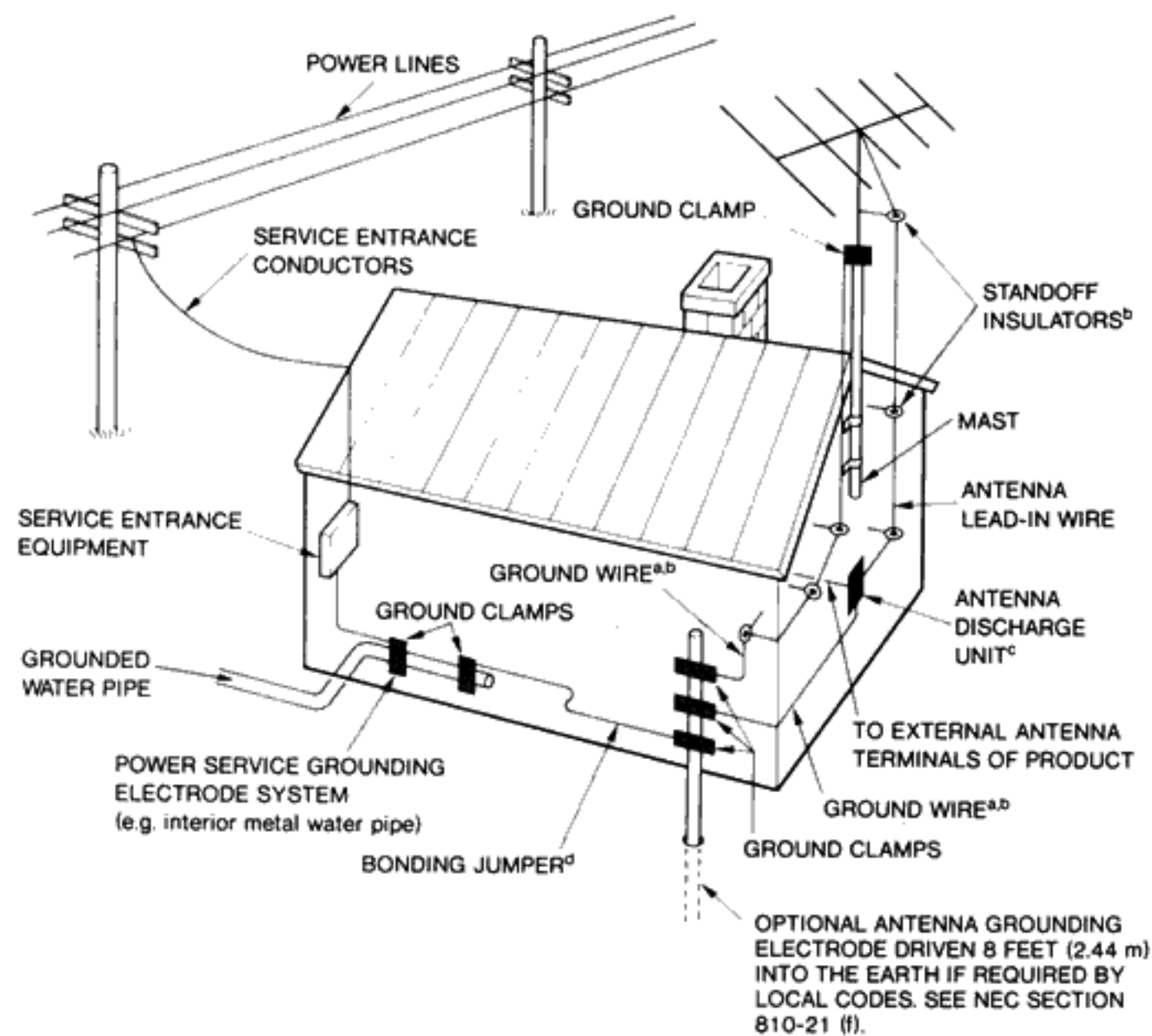

- a. Use No. 10 AWG (5.3 mm²) copper, No. 8 AWG (8.4 mm²) aluminum, No. 17 AWG (1.0 mm²) copper-clad steel or bronze wire, or larger, as a ground wire.
- b. Secure antenna lead-in and ground wires to house with stand-off insulators spaced from 4–6 feet (1.22–1.83 m) apart.

- c. Mount antenna discharge unit as close as possible to where lead-in enters house.
- d. Use jumper wire not smaller than No.6 AWG (13.3 mm²) copper, or the equivalent, when a separate antenna-grounding electrode is used. See NEC Section 810-21 (f).

Controls and Functions

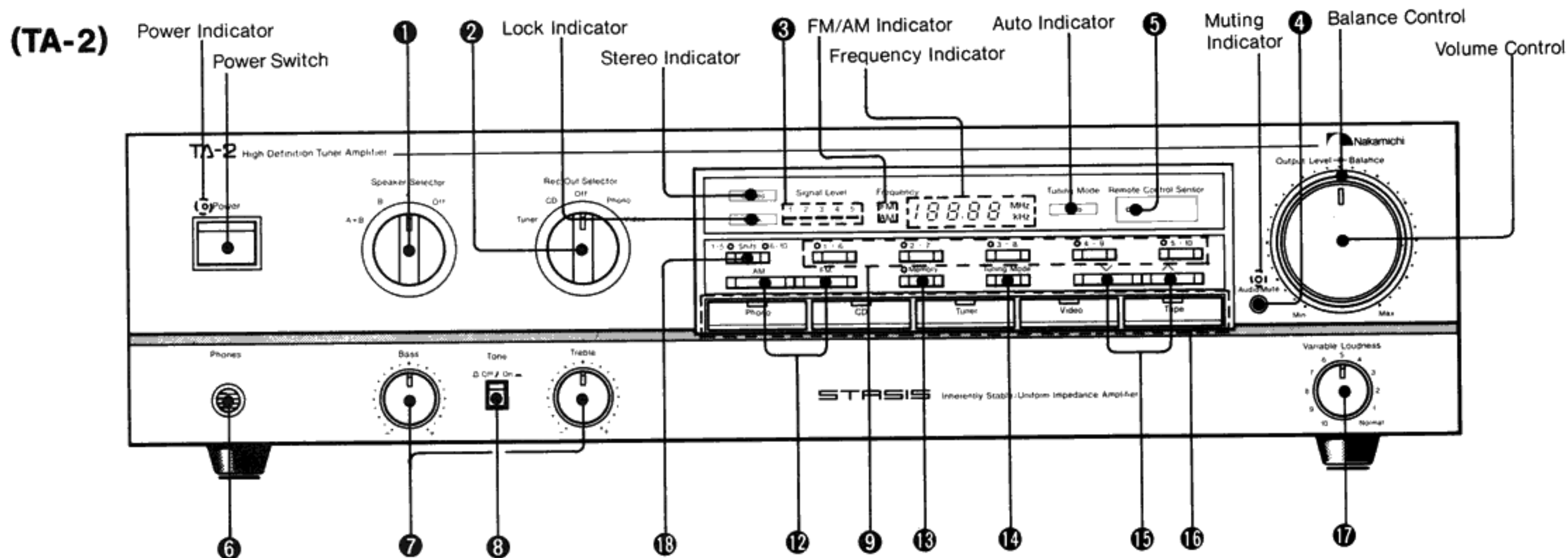
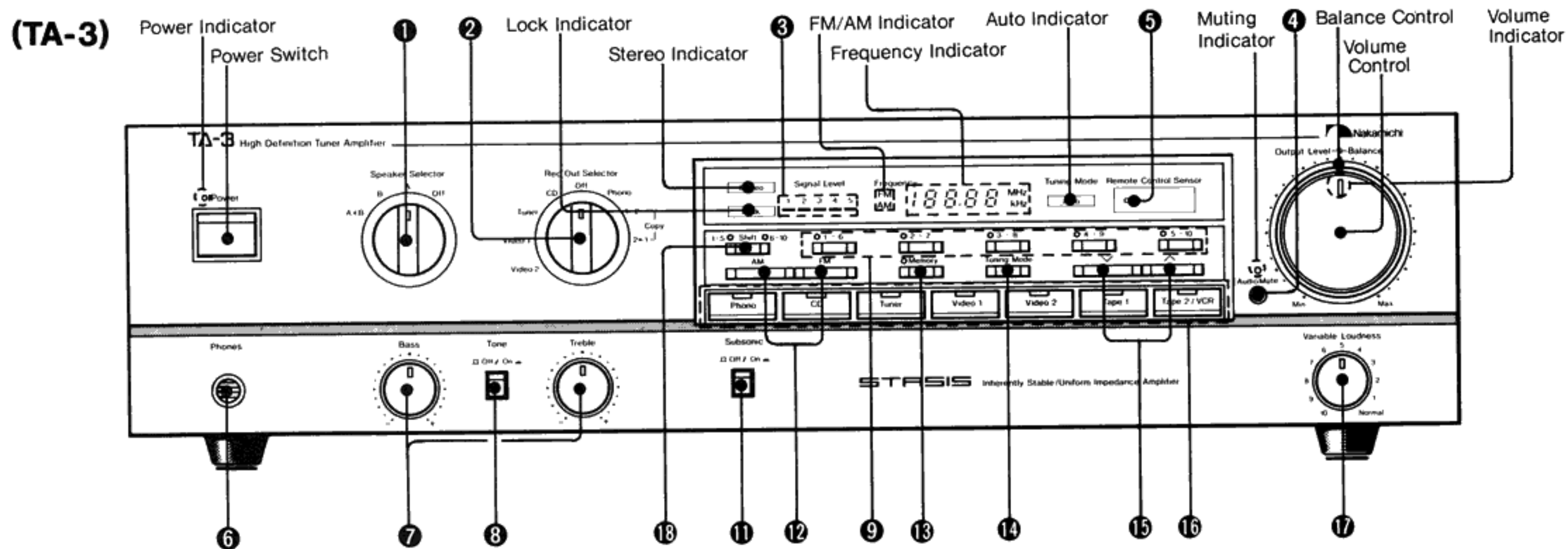
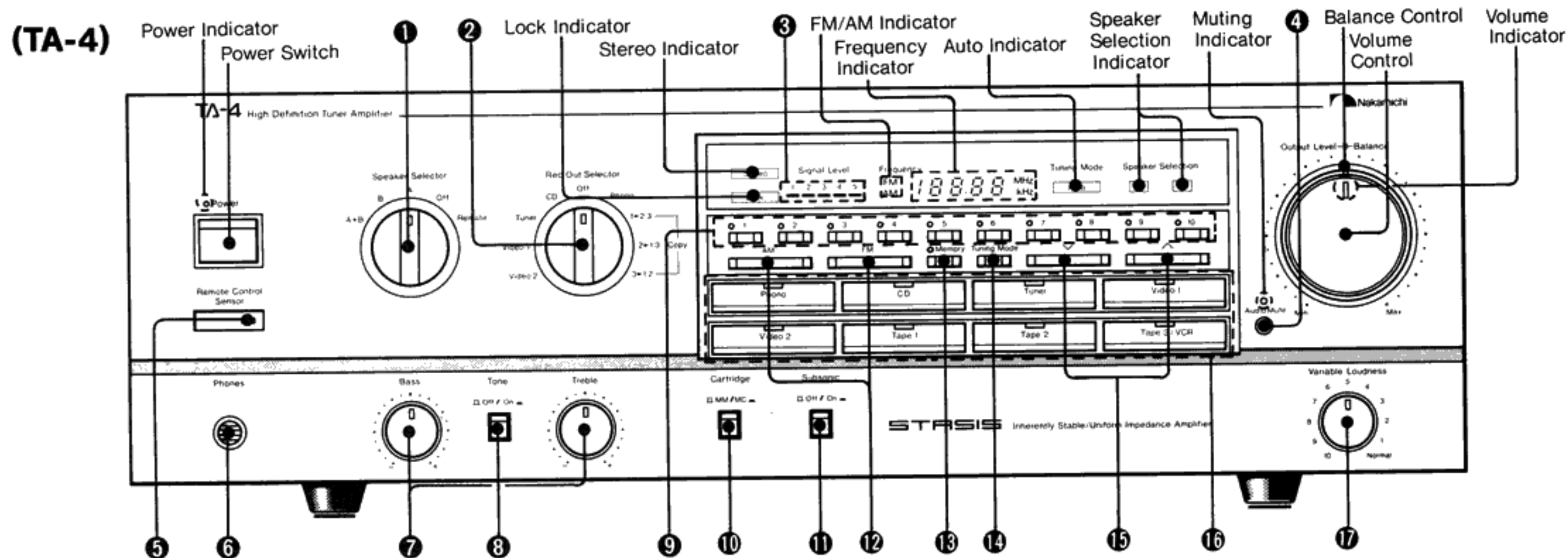

1 Speaker Selector

This selector controls two pairs of speakers (A and B) which can be connected to the tuner amplifier. Setting the selector to "A + B" permits parallel drive of both pairs.

To listen with headphones only, set the selector to "Off."

When the selector of the TA-4 is set to "Remote," the speakers can be selected using the supplied wireless remote control unit (RM-4TA).

2 Rec Out Selector

This selector determines which signal is routed to the tape outputs. The chosen setting is completely independent from the position of the Listen Monitor Selector.

• Off:

The tape output jacks carry no signal and are completely disengaged from the internal circuits, for further enhanced sonic purity. We recommend setting the selector to this position when tape recording is not being carried out.

• Phono/CD/Tuner/Video1/Video2 (Video):

The signal of the designated program source is supplied at the tape outputs.

• 1▶2,3/2▶1,3/3▶1,2 Copy (TA-4), 1▶2/2▶1 Copy (TA-3):

These positions are used for tape dubbing. In the 1▶2,3 position, for example, tape dubbing can be carried out from tape deck 1 to tape decks 2 and 3.

3 Signal Strength Meter

Displays the field strength of the received broadcast signal.

4 Audio Mute Switch

By pressing this switch, the listening level is reduced to one tenth (-20dB). While the muting circuit is active, the Muting indicator lights up. To release the muting mode, press the switch once more.

5 Remote Control Sensor

The infrared signals from the supplied remote control unit are picked up by this sensor.

The indicator lights up when a signal is being received. (→ page 18).

6 Headphone Jack

A pair of stereo headphones can be connected to this jack. The impedance of the headphones should be between 8 and 150 ohms.

7 Tone Controls

Serve to adjust the tonal balance. By turning a knob clockwise, the respective range is emphasized, and by turning it counterclockwise, the frequencies are attenuated. To activate the tone control circuits, set the Tone switch to "On."

• Bass:

From the center clickstop position, adjustment is possible within the range of ± 10 dB (at 20 Hz).

• Treble:

From the center clickstop position, adjustment is possible within the range of ± 10 dB (at 20 kHz).

8 Tone Switch

Setting this switch to "On" activates the tone control circuits.

9 Preset Station Buttons

A total of 10 AM/FM broadcast stations can be stored in these buttons for instant recall (→ page 15). When a memorized station has been selected with one of the Preset Station buttons, the respective indicator above the button lights up.

10 Cartridge Selector (TA-4)

Set this switch to the correct position for the type of phono cartridge in use. (→ page 16).

11 Subsonic Filter Switch (TA-4/TA-3)

When the Listen Monitor selector is set to "Phono," a subsonic filter can be activated with this switch, in order to cut low-frequency noise such as turntable rumble. The filter affects not only the loudspeaker signal but also the tape outputs, to prevent subsonic noise from being recorded when dubbing phonograph records onto tape.

12 FM/AM Band Selector

These buttons are used to select the desired frequency band. For reception of a station stored in the Preset Station buttons, it is not necessary to operate the Band selector.

13 Memory Button

This button is used to store broadcast stations into the Preset Station buttons (→ page 15).

14 Tuning Mode Selector

This button serves to select either the automatic or the manual tuning mode. In the automatic tuning mode, the Auto indicator lights up, stereo reception is possible and the FM muting circuit is enabled. In the manual mode, reception is switched to mono and the FM muting circuit is defeated, to permit searching for weak stations. As interstation hiss will be heard during tuning, the volume control setting should be reduced to a safe level before using the manual mode.

15 Tuning Buttons

These buttons are used to tune in FM or AM broadcast stations. Depending on the setting of the Tuning Mode selector, pressing a button either activates the Auto Seek function or causes a manual frequency change.

16 Listen Monitor Selector

The desired program source for listening can be chosen with these buttons, independent of the Rec Out selector setting. When a button is pressed, the indicator above it lights up. The indicator also lights when a program source is chosen with the remote control, for easy visual confirmation. When the unit is in the standby mode (→ page 15), pushing one of these buttons will activate the tuner amplifier and other equipment connected to the "Switched" AC power outlet of this unit, and the selected source can be heard (direct operation).

17 Variable Loudness Control

This control permits precise compensation of subjective bass and treble losses which occur at low listening levels. (Refer to "Use of the Variable Loudness Control" below.)

18 Shift Button (TA-3/TA-2)

This button selects either the 1-5 range or the 6-10 range of the five Preset Station buttons. The indicators show which range is selected.

If no Preset Station button is pressed within five seconds or if another tuning operation is performed, the unit reverts to the previously selected range.

■ Use of the Variable Loudness Control

As the human ear becomes less sensitive to the frequency extremes with decreasing loudness, the sound at low listening levels often tends to appear thin and lacking in brilliance. The Variable Loudness control of this unit permits fine-tailored compensation, in order to maintain an equal perceived sound balance at all levels. When listening at fairly high settings under typical conditions, the control should be set to the "Normal" position and slight volume and tonal adjustments should be made with the Volume and Tone controls to achieve the optimum sonic balance. Then, when wishing to listen at a considerably softer volume, leave the Volume and Tone control settings unchanged and reduce the level by turning the Variable Loudness control counterclockwise. This reduces the volume and at the same time introduces the required amount of loudness compensation (bass and treble boost) for unaltered sonic balance.

Loudness Curves

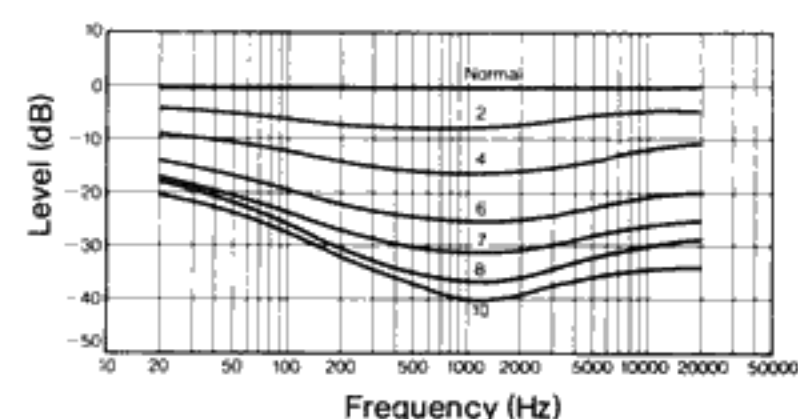

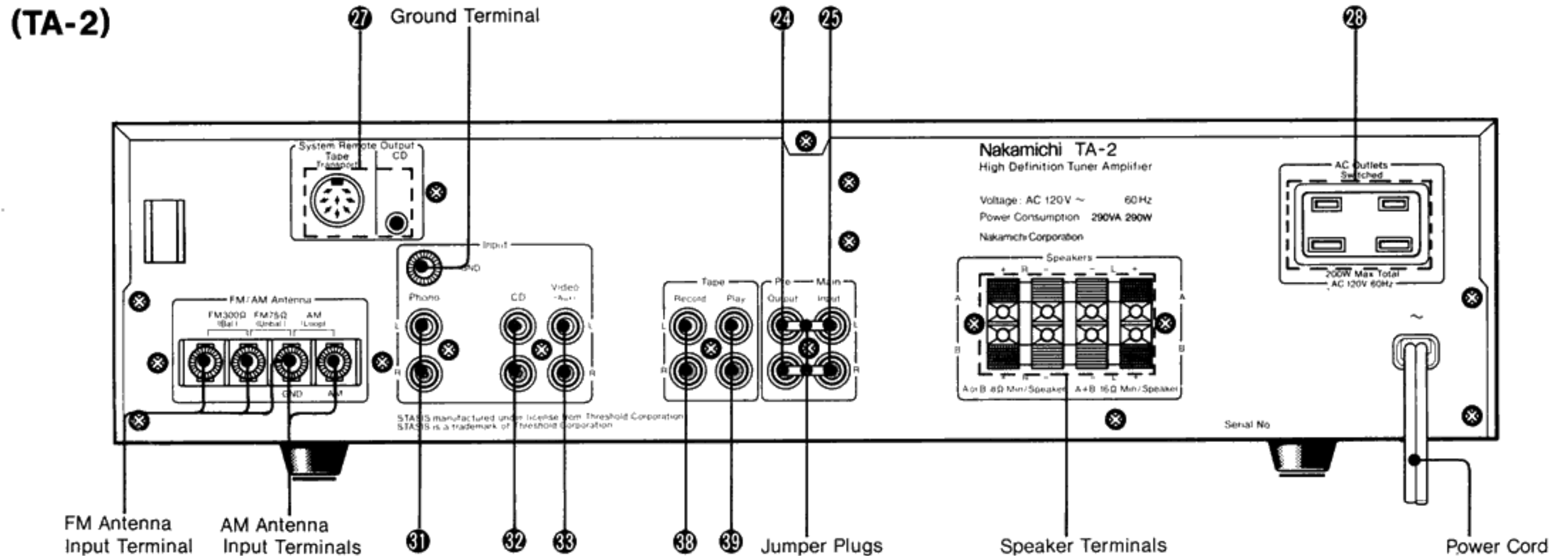
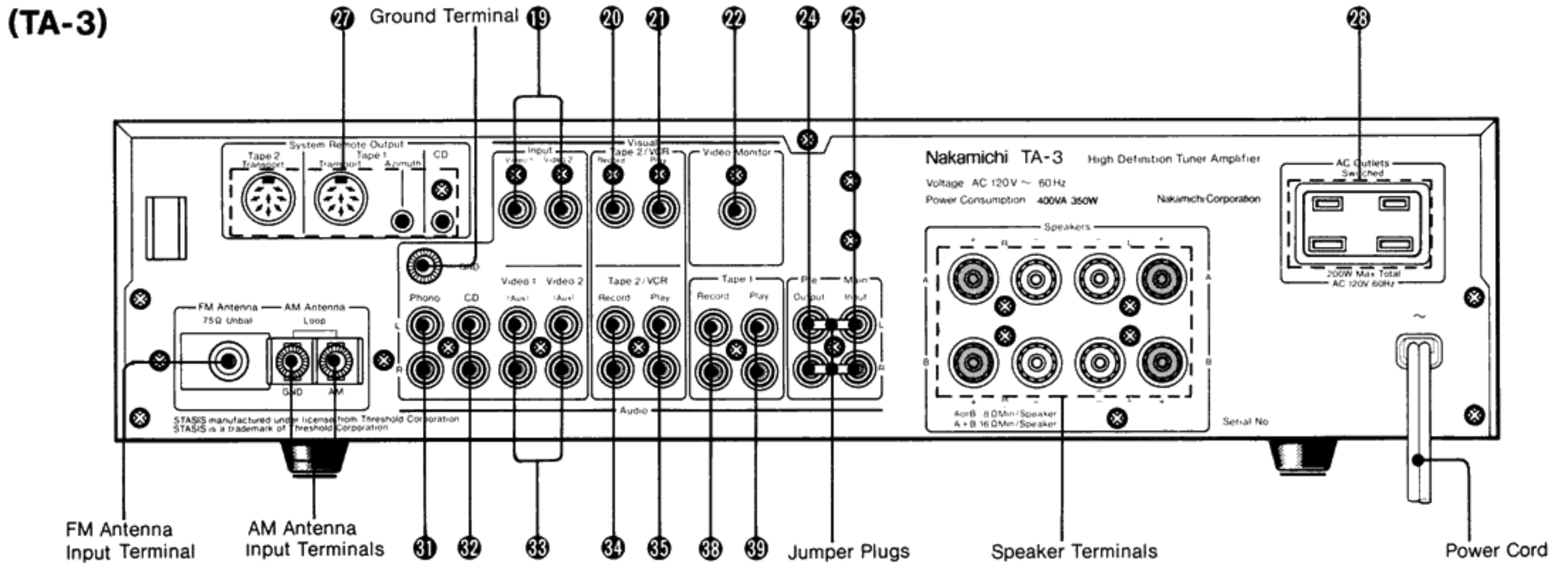
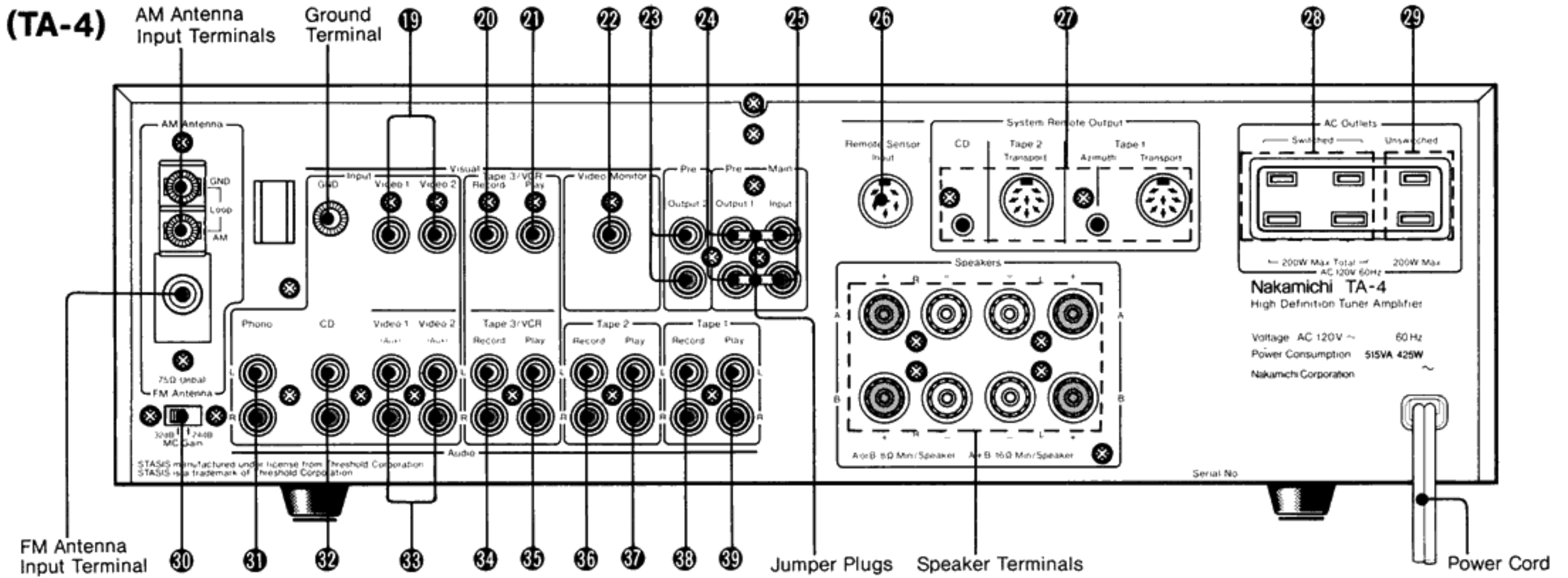

19 Video Input Terminals (TA-4/TA-3)

20 Tape 3/VCR (TA-4), Tape 2/VCR (TA-3) Video Record Terminal (video output)

21 Tape 3/VCR (TA-4), Tape 2/VCR (TA-3) Video Play Terminal (video input)

22 Video Monitor Terminal (video output) (TA-4/TA-3)

When a video monitor or a TV with provisions for video input is connected to this jack, the video signals supplied from the "Video" or "Tape 3/VCR (TA-4), Tape 2/VCR (TA-3)" input terminals can be switched by the tuner amplifier and viewed on the monitor.

23 Pre Output 2 Terminals (TA-4)

These jacks may be used to connect a separate power amplifier. (➔ page 14)

24 Pre Output 1 Terminals (TA-4), Pre Output Terminals (TA-3/TA-2)

25 Main Input Terminals

These jacks may be used to insert a device such as a surround sound processor or graphic equalizer in the signal path. If no equipment is connected, the jumper plugs inserted in the jacks must be left in place (➔ page 14).

26 Remote Sensor Input (TA-4)

The optional Remote Sensor RS-7 can be connected to this terminal, to expand remote tuner capabilities to other areas at a greater distance from the tuner amplifier or in separate rooms. (➔ page 14).

27 System Remote Output Connectors

Other Nakamichi components, such as one or two tape decks and a CD player with suitable inputs can be connected to these terminals, for integrated remote control of the entire system. (➔ page 14)

28 AC Outlets (Switched)

These convenience outlets are controlled by the Power switch on the unit's front panel. The total power consumption of equipment connected to these outlets may not exceed 200 watts.

(On the models TA-4E/TA-3E/TA-2E and the TA-4/TA-3/TA-2 for Oceania, the outlet type is different from that shown in the illustration, and there is only one outlet.)

29 AC Outlet (Unswitched) (TA-4)

This convenience outlet is independent of the Power switch on the unit's front panel. The power consumption of equipment connected to this outlet may not exceed 200 watts.

(The models TA-4E and TA-4 for Oceania do not have this outlet.)

30 MC Gain Selector (TA-4)

This switch controls the gain of the moving-coil phono stage. Select the position that matches the output voltage of your moving-coil cartridge (➔ page 16).

31 Phono Input Terminals

The phono input of the TA-4 accepts either moving-coil or moving-magnet cartridges. The input of the TA-3 and TA-2 is designed for moving-magnet cartridges only.

32 CD Player Input Terminals

33 Video 1. 2 (Aux)(TA-4/TA-3), Video (Aux) (TA-2) Input Terminals (audio input)

The audio signals of A/V equipment or of auxiliary audio equipment can be connected to these jacks.

34 Tape 3/VCR (TA-4), Tape 2/VCR (TA-3) Record Terminals (audio output)

Audio signals can be supplied to a third (or second) tape deck or to a videocassette recorder from these jacks.

35 Tape 3/VCR (TA-4), Tape 2/VCR (TA-3) Play Terminals (audio input)

Audio signals from a third (or second) tape deck or a videocassette recorder can be connected to these jacks.

36 Tape 2 Record Terminals (TA-4) (audio output)

Audio signals can be supplied to a second tape recorder from these jacks.

37 Tape 2 Play Terminals (TA-4) (audio input)

Audio signals from a second tape recorder can be connected to these jacks.

38 Tape 1 (TA-4/TA-3), Tape (TA-2) Record Terminals (audio output)

Audio signals can be supplied to a tape deck from these jacks.

39 Tape 1 (TA-4/TA-3), Tape (TA-2) Play Terminals (audio input)

Audio signals from a tape deck can be connected to these jacks.

Connections

(The chart shows a connection example for the TA-4)

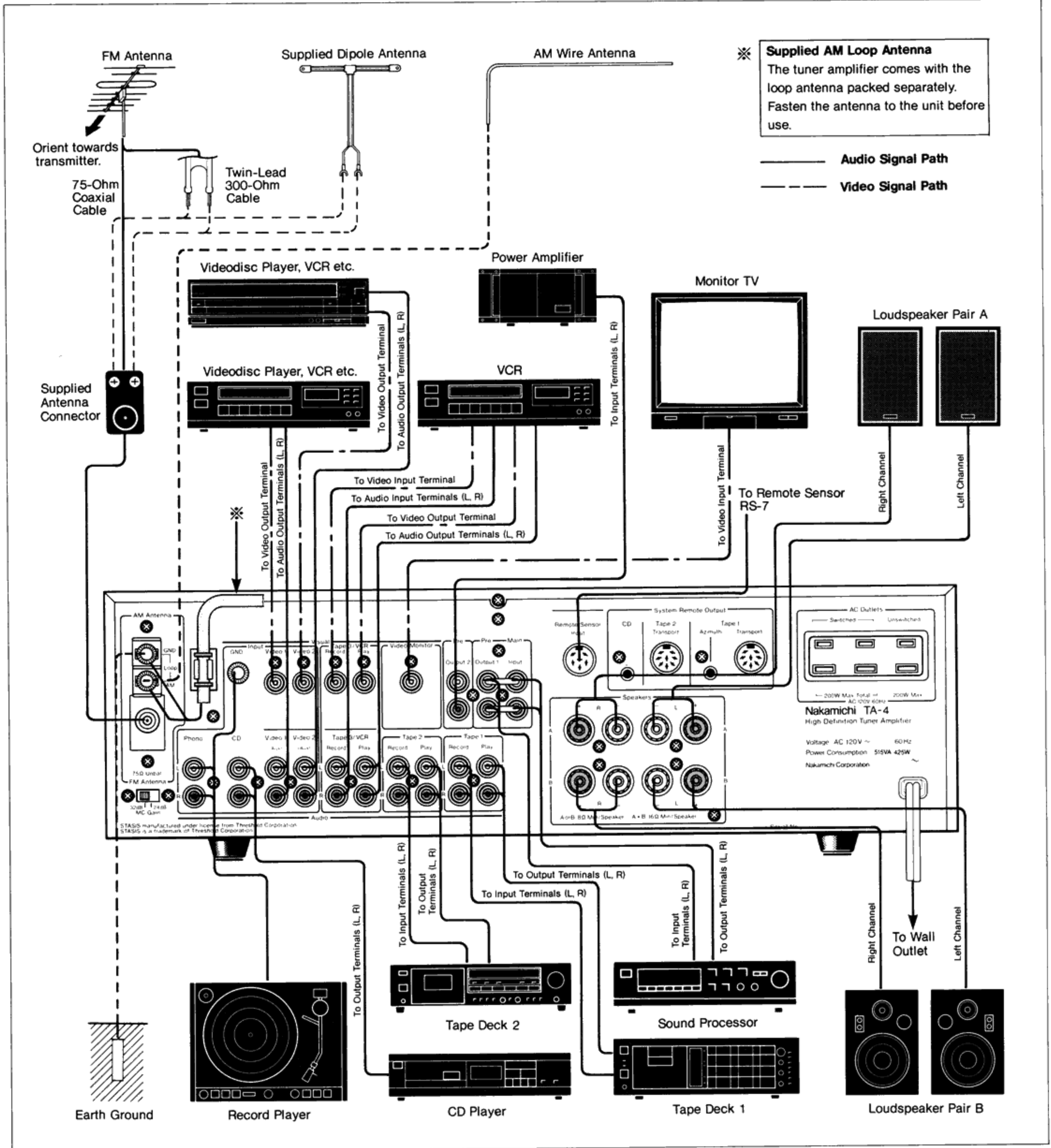

Establish connections to other system components as shown in the example. While making connections, the power switches of all components must be set to "OFF."

- For easy identification, the input and output terminals of this unit are color coded. Video signal input and output jacks are yellow. Audio

Speaker Connections

Connect the left-side loudspeaker to the left-channel speaker terminals and the right-side loudspeaker to the right-channel speaker terminals of this unit, taking care to observe correct (+) and (-) polarity. If the polarity of one speaker is reversed, the speakers will be out of phase, causing a loss in bass response and unstable, irregular stereo imaging. Double-check to make sure that both speakers have the same polarity.

- It is recommended that you use high-quality, heavy-gauge speaker cable with low resistance, designed specially for audio applications. Using thin cable with high resistance may impair sound quality and prevent the unit from delivering its full potential.
- The speaker cables for both channels should be approximately equal in length, as a marked difference can result in improper left/right balance.

input and output jacks are white for the left channel and red for the right channel.

- When connecting A/V equipment to this unit, use only specially designed video cables for the video input and output connections. If other cables are used, impedance mismatching may impair picture quality.

- Except for the jumper plugs in the Pre Output 1/Main Input (TA-4) or Pre Output/Main Input (TA-3/TA-2) terminals, **never** insert any shorting plugs or the like into unused input or output jacks, as this can cut off the sound or cause damage to the unit.

- Pay attention to the power handling capability of connected loudspeakers. Especially if it is lower than the maximum rated output of this unit and the tuner amplifier is driven close to its full capacity, damage to the speakers may result.

- The high-current design of this tuner amplifier permits stable operation over a fairly wide range of speaker load impedances. **However, if two pairs of speakers are driven in parallel, do not turn up the volume to excessive levels.**

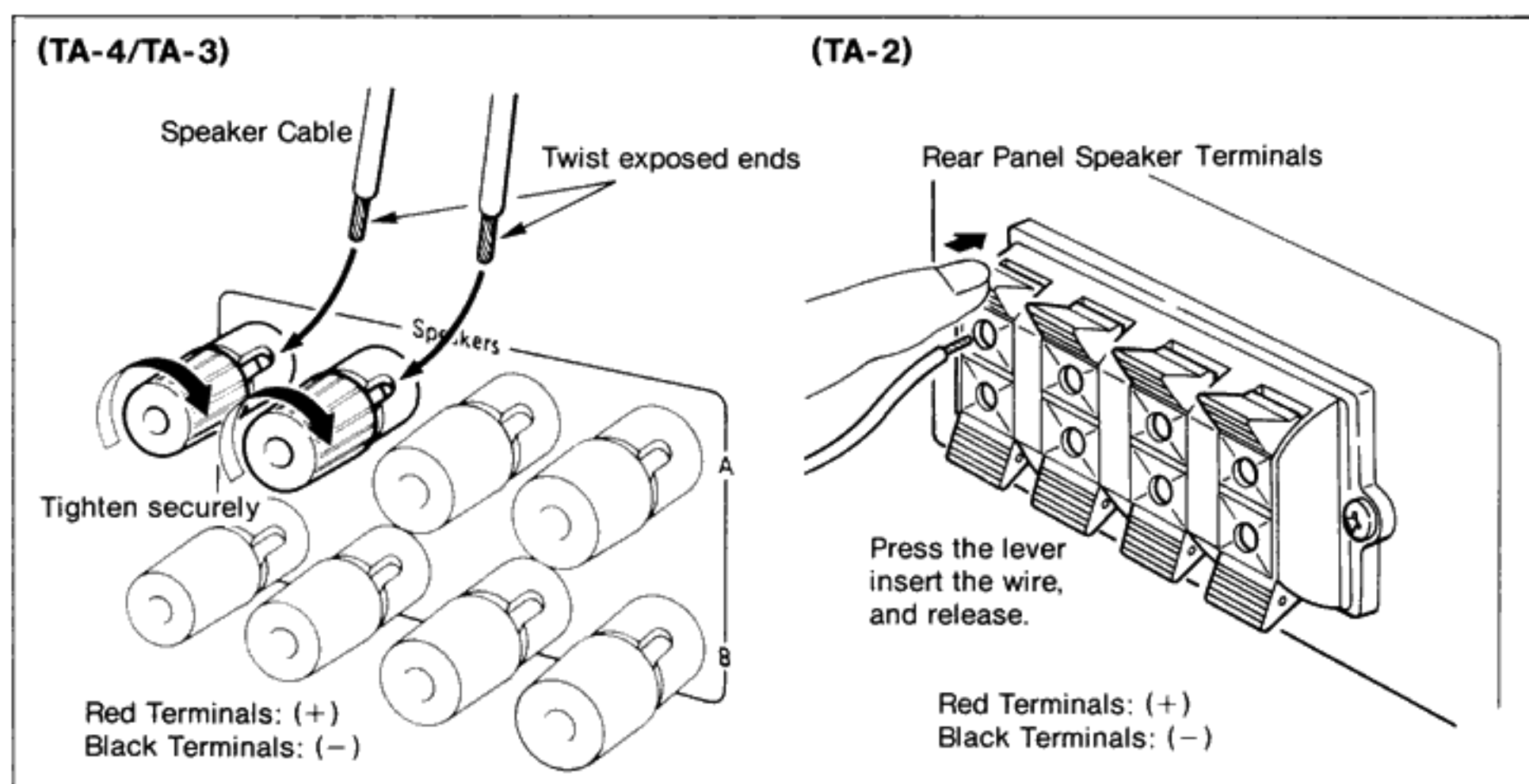

FM Antenna Connection

Using a properly designed high-quality FM antenna is an essential prerequisite for good FM reception. When choosing the type and location of the antenna, take the following points into consideration.

1. Choose the antenna which is best for your location.

< Areas in close proximity to strong stations >

In urban areas, buildings or other reflective objects may cause multipath interference, which notably degrades sound quality. In such cases, the use of a highly directive 2-element phase difference feed antenna is recommended. This type of antenna has relatively low sensitivity, but it can suppress unwanted reflections of the broadcast signal. In particularly problematic locations, such as near many tall buildings, a 5-element or 8-element antenna with even higher directivity may be required. As this type of antenna also has high gain, it may be desirable to use an attenuator in order to prevent overload of the tuner input stage.

- If the supplied 300-ohm twin-lead folded dipole is used, extend the cable leads and orient them for best reception. However, keep in mind that the directivity and sensitivity of this dipole usually is not sufficient for satisfactory FM stereo reception. The dipole is intended mainly as a temporary solution, until a regular FM antenna can be installed.

< Fringe areas at a considerable distance from stations >

In such areas, an outdoor FM antenna with 5 to 8 elements is required. Usually, the antenna should be mounted as high as possible for best results.

2. Install the antenna correctly.

To prevent the possibility of noise interference, the antenna should be kept as far away as possible from noise sources, such as roads with heavy traffic, high-voltage power lines, etc. Adjust the height and direction of the antenna carefully for best reception.

3. Use a good antenna cable and keep cable runs short.

The longer the antenna cable, the higher its internal loss and susceptibility to noise pickup. Using a short run of high-quality coaxial cable (such as RG-6 or RG-59) is the most desirable solution. If long cable runs are necessary, a low-loss coaxial cable should be chosen.

■ Using the Antenna Adapter (TA-4/TA-3 and European model TA-2)

The supplied antenna adapter should be used to establish the connection to an FM antenna. 75-ohm coaxial cable as well as 300-ohm twin-lead cable can be terminated with this adapter plug. In the latter case, the adapter converts the impedance to the 75 ohms required for the unit's input terminal.

1. Connection of 75-Ohm Coaxial Cable

- (1) Prepare the coaxial cable as shown in Fig. 1.
- (2) Release the lock claws on the side of the antenna

connector in the direction of the arrows and pull the cover off. (Fig. 2)

(3) TA-4/TA-3 except for European model

Remove ring A and slide it on the boss on the inside of the cover. Loosen screws B, insert the coaxial cable, and fasten the center conductor firmly with clamp C. Then tighten screws B and replace the cover. (Refer to Fig. 3)

- When 300-ohm twin-lead cable is to be used, replace the ring A in its original position.

European Model

Remove the wire from clamp A and place it to the outside of partition B, using needlenose pliers or the like. Then insert the center conductor of the coaxial cable into clamp A, squeeze claws C and D with the pliers to fasten the shield braid and insulation, and replace the cover. (Refer to Fig. 3)

- When 300-ohm twin-lead cable is to be used, replace the wire removed from clamp A in its original position.

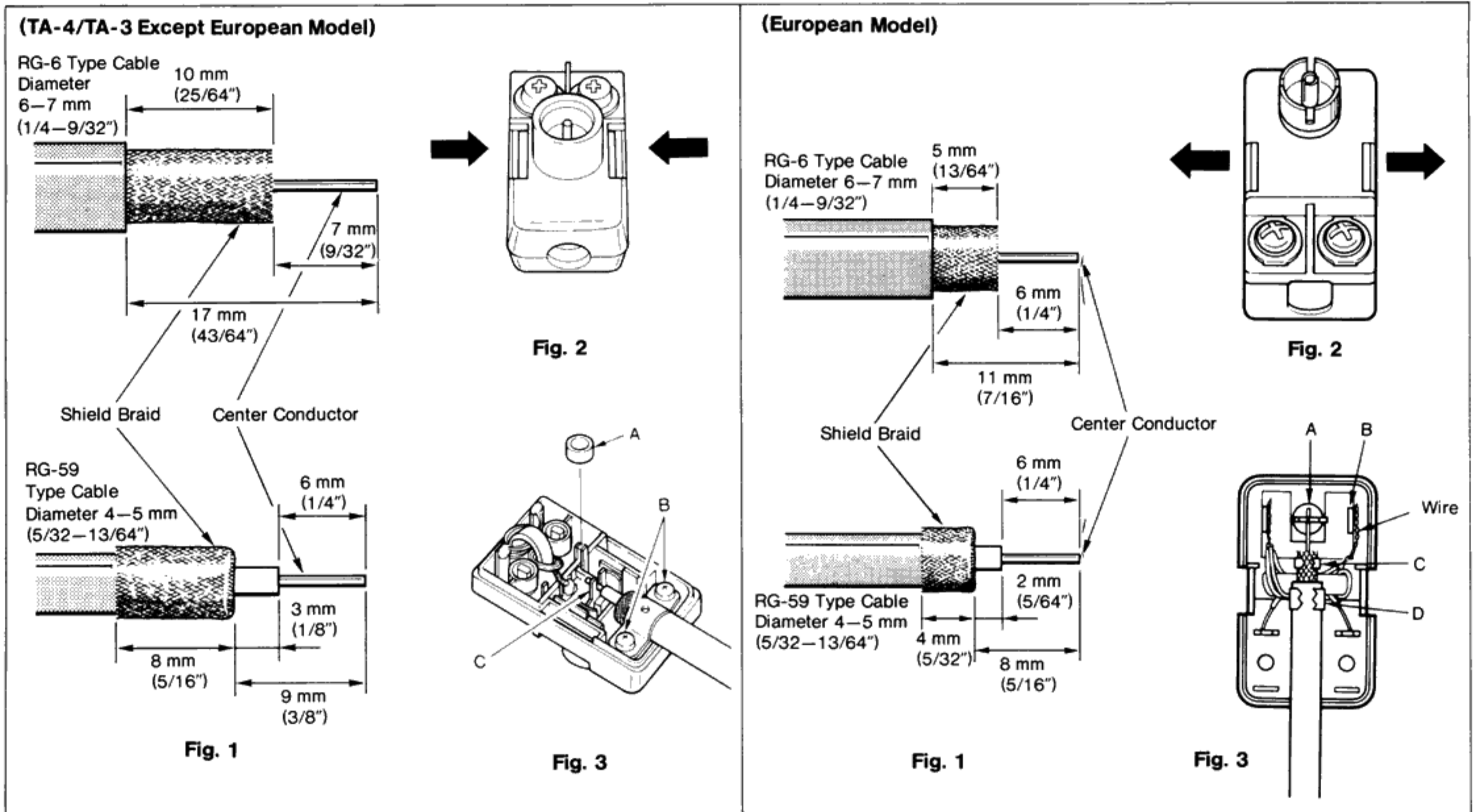

2. Connection of 300-Ohm Twin-Lead Cable

Connect the feeder cable to the screw terminals on the outside of the adapter, as shown in the illustration.

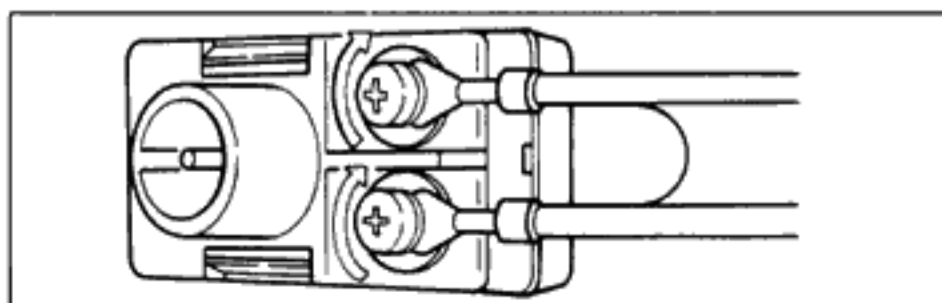

■ Rear-Panel Connections (TA-2)

< 75-Ohm Coaxial Cable >

Prepare the coaxial cable as shown in the illustrations. Connect the center conductor to the terminal marked "FM 75Ω" and the shield braid to the "GND" terminal.

< 300-Ohm Twin-Lead Cable >

Connect one lead of the feeder cable to the terminal marked "FM 300Ω" and the other lead to the terminal marked "FM 75Ω".

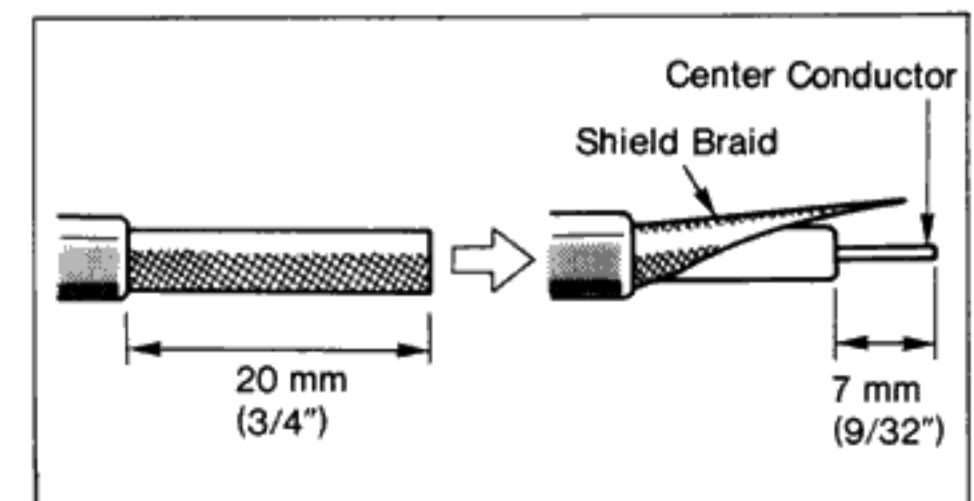

AM Antenna Connection

Connect the cable of the supplied AM loop antenna to the AM antenna terminal of the tuner amplifier and attach the antenna to the bracket on the rear of the unit. Orient the loop antenna for maximum number of signal-strength meter segments lit when receiving a desired station. The loop antenna may also be removed from the bracket and fastened for example to a wall with the supplied wall-mounting bracket (refer to the illustration). If reception conditions with the loop antenna are unsatisfactory, extend an additional antenna wire (ordinary vinyl-coated lead wire) about 4 to 5 meters outdoors and connect one end of the wire to the AM antenna terminal marked "AM." The loop antenna should remain connected also when using an outdoor antenna wire.

- **For TA-4/TA-3 Users:**

If video equipment or a monitor is connected to the unit and AM reception is carried out while the power switches of the video components are set to "On," noise interference may occur.

In such a case, remove the AM loop antenna and feeder cable as far as possible from the receiver, the TV set and the video connecting cables or switch the video equipment off.

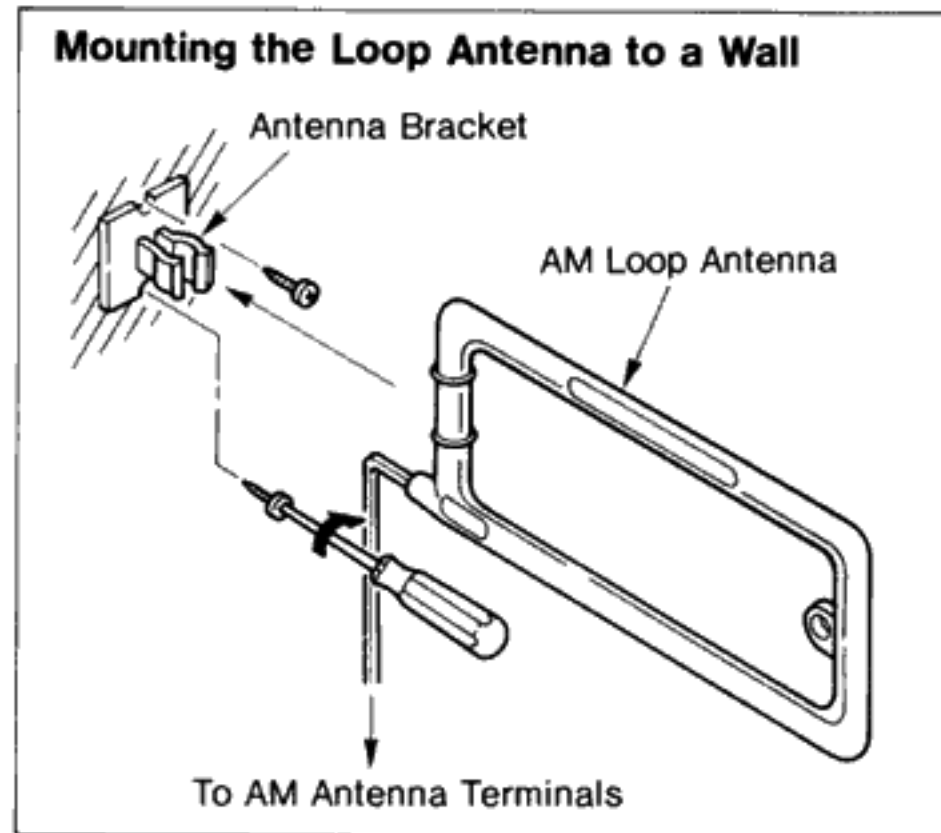

Ground Connection

When reception with the AM loop antenna is satisfactory, there is no need to establish a separate ground connection. If reception suffers from excessive hum or noise, a ground wire may help to reduce such problems. Connect one end of the wire to the AM antenna terminal marked "GND" and the other end to an earth ground, i.e. more than 50 cm length of exposed wire or a copper bar buried in the ground, or a metal water pipe with complete grounding. **To avoid fire hazard; Never connect the ground wire to a gas pipe!**

- If an outdoor AM antenna wire is used, grounding must be provided for protection against lightning.

Power Supply Connections

(TA-4A/TA-3A/TA-2A, TA-4/TA-3/TA-2 except for Oceania model)

The plug and cable of this unit's power cord are polarity coded. The plug should be inserted into a wall outlet so that the prong with the wide lip (connected to the lead marked by a white line) enters the longer slot, which is the grounded side of the outlet.

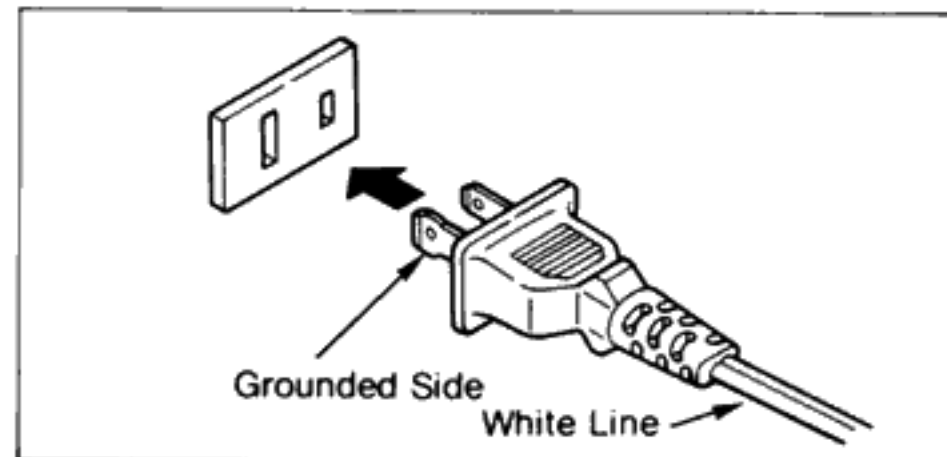

CAUTION:

TO PREVENT ELECTRIC SHOCK DO NOT USE THIS (POLARIZED) PLUG WITH AN EXTENSION CORD, RECEPTACLE OR OTHER OUTLET UNLESS THE BLADES CAN BE FULLY INSERTED TO PREVENT BLADE EXPOSURE.

AC Convenience Outlets

On the rear panel of this unit, convenience outlets are provided which can be used to supply AC power to other components of the system. **Make sure that the total power consumption of equipment connected to the Switched outlets does not exceed 200 watts.** To the Unswitched outlet (TA-4), another piece of equipment can be connected, **which also must have a power consump-**

tion of less than 200 watts.

These outlets are also polarity coded. The long slot is at the same potential as the power cord's grounded side. (TA-4A/TA-3A/TA-2A, TA-4/TA-3/TA-2 except for Oceania model)

- **Never connect any ordinary household appliances to these outlets,** as the power capacity may be exceeded and a fire risk will be incurred.

- **Do not connect TV sets, color monitors etc. to these outlets.** The switch-on current of such devices is considerably higher than their normal rated power consumption, so that the capacity of the outlets may be exceeded, even if the rated consumption seems to be within permissible limits

Protection Circuits

To guard against possible damage to the tuner amplifier and connected equipment, this unit incorporates separate circuits for the left and right channel, which constantly monitor operating conditions. If the temperature of the internal heat sinks exceeds approx. 100°C, if the unit was driven to excessive levels or if DC current has leaked into the output, a relay cuts off the output in both channels. In this condition, the power supply is not deactivat-

ed, i.e. the unit is not completely switched off. When regular conditions are restored, the receiver automatically reverts to normal operation. The above mentioned cases may result from unsuitable connections, improper installation (restricted air flow prevents heat exchange), or abnormal use (such as driving very low-impedance speakers at high levels for an extended period).

If the protection circuits are activated frequently,

first turn down the volume control, then switch off the power and check connections of all components as well as installation conditions. If these checks reveal no particular problem and the protection circuit is activated again after the unit was switched on, contact an authorized service station.

Use of the Pre Output 1/Main Input (TA-4) or Pre Output/Main Input (TA-3/TA-2) Terminals

The Pre Output 1/Main Input (TA-4) or Pre Output/Main Input (TA-3/TA-2) terminals on the rear panel of the unit permit connection of signal-processing equipment such as a sound processor or graphic equalizer. To use the terminals, first remove the jumper plugs joining the Main Input and the Pre Output jacks. Then connect the input terminals of the equipment to the Pre Output jacks and the output terminals of the equipment to the Main Input jacks on the unit.

- When these terminals are not used, the supplied jumper plugs must be inserted in the jacks, as otherwise the sound is cut off.
- If jumper plugs are removed or inserted while the unit is switched on, noise bursts may damage the speakers. Be sure to set the Power switch to "Off" before altering any connections.

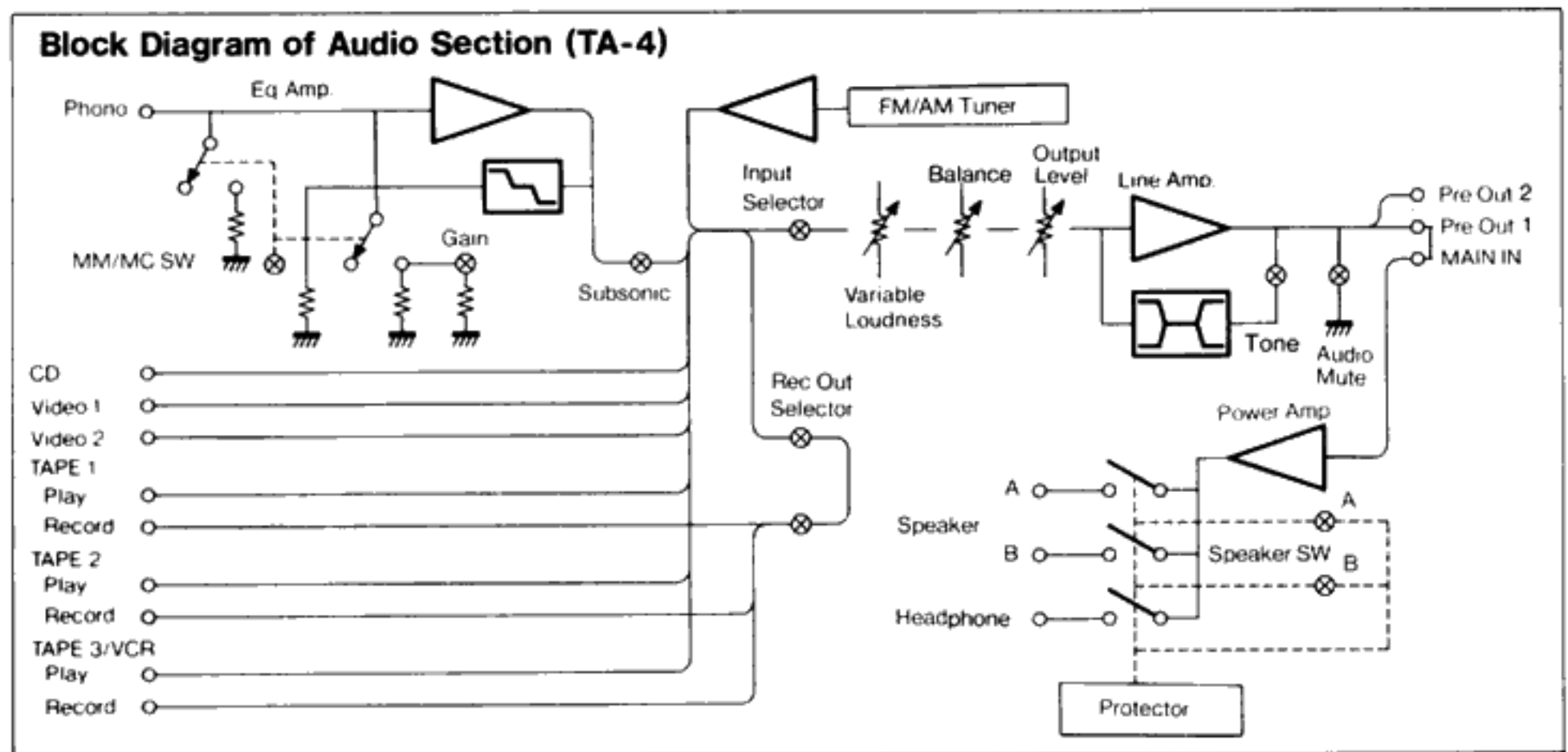

Power Amplifier Connections

The Pre Output 2 jacks on the rear panel of the TA-4 may be used to connect an external power amplifier. This permits simultaneous reproduction of a program source over the built-in power amplifier of the TA-4 and the external power amplifier.

When wishing to use only the external power amplifier, set the Speaker selector of the TA-4 to "Off."

By using the Pre Output jacks of the Pre Output/Main Input jacks on the TA-3/TA-2, it is also possible

to connect an external power amplifier. However, in this case the program source is reproduced over the external power amplifier only.

System Remote Control Connections

By connecting the system Remote outputs on the rear panel of the unit to the remote control input

terminals of other Nakamichi products, the wireless remote control unit supplied with the tuner

amplifier can be used to operate all essential functions of the other components (→ page 18).

Connector Designations and Required Cables

(TA-4)

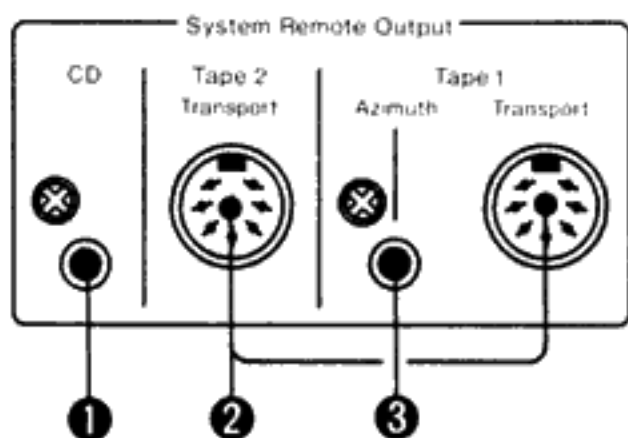

① CD Player Control Terminal

This terminal permits remote control of Nakamichi CD players, using accessory equipment to be introduced in future.

With the models OMS-4/OMS-3/OMS-2/OMS-1/CDP-2/CDC-4/CDC-3, system remote control with the remote control unit of the tuner amplifier is possible also without using this terminal.

When the TA-4 is used in conjunction with an RS-7 unit for system remote control for example from another room, the system remote control terminal of the CD player **must** be connected to the CD Player control terminal of the TA-4, using the optional control cable SRC-2.

(TA-3)

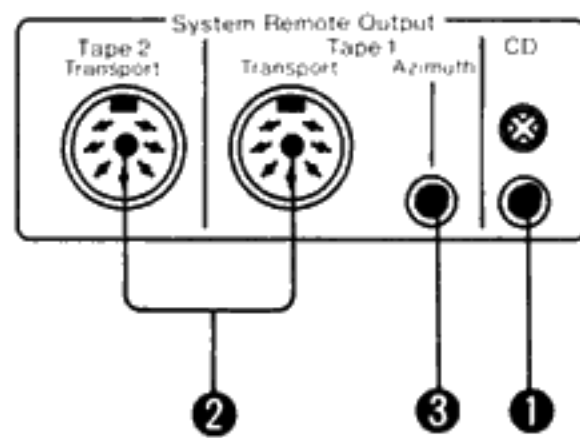

② Tape Deck Transport Connector

This terminal permits control of the basic operation functions of any Nakamichi cassette deck with a remote control input (except for the 480 series).

Use the supplied Tape Deck Control cable to connect the jack to the remote control input of the tape deck (TA-4/TA-3). For the TA-2, the cable SRC-1 must be purchased separately.

③ Tape Deck Azimuth Adjustment Connector (TA-4/TA-3)

The signal supplied at this terminal serves for adjustment of playback head azimuth in the Nakamichi CR-7 cassette deck. Use the optional Tape Deck Control cable SRC-2 to connect the jack to the remote control input on the tape deck.

(TA-2)

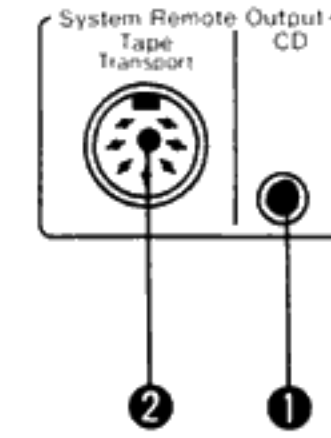

- If two tape decks are to be connected for system remote control, purchase the optional Tape Deck Remote Control Cable SRC-1. For the Nakamichi models 1000/1000II/700/700II, the control cable SRC-3 is required.

Connection of Remote Sensor Unit RS-7 (TA-4)

When wishing to expand the remote control capability of the TA-4 and connected components to other listening areas at a greater distance from the unit or in separate rooms, the optional Remote Sensor RS-7 can be used. (Up to three RS-7 units may be connected in series, provided that the total cable length is not more than 100 meters.) To establish the connection, merely plug the cable supplied with the RS-7 into the Remote Control Link input on the rear panel of the TA-4. See the RS-7 Owner's Manual for details.

Extra remote control units (RM-4TA) may also be purchased separately, so you can keep one in each listening area, for utmost convenience.

Operation

[Before Operation]

Before operating the unit, make sure that the Volume control is fully turned to minimum. For a brief period after power to this unit is switched on, the output remains muted and no sound will be heard, until all internal circuits have stabilized.

- Make sure that all connections are properly established.
 - (1) Turn the Volume control fully to minimum.
 - (2) Set the Power switch to "On."
 - (3) Select the desired program source and loudspeaker pair.
 - (4) Adjust the listening volume and tonal balance as desired.

Power On/Off Switching

When the Power switch on the front panel of the tuner amplifier is pressed, the unit will enter the regular operating condition after a brief muting period (to allow all internal circuits to stabilize). The operating status is shown by the Power indicator.

Power Indicator Condition	Operating Condition of the unit
Out	Power is off
Amber (lit)	Standby mode
Green (flashing)	Power is on (muting interval)
Green (lit)	Power is on (Regular operation)

■ Power On/Off Switching With the Remote Control

When wishing to control power On/Off with the wireless remote control unit, set the Power switch of the tuner amplifier to "On" and then operate the Power On/Off button of the remote control. When the power was switched off with the remote control, the tuner amplifier enters the **standby mode** (waiting for input from the remote control). Pressing the Power On/Off button of the remote control once more will activate the tuner amplifier again. Operating the Listen Monitor selector (either on the unit itself or on the remote control) will also activate the unit.

Leaving the unit in the standby mode and using the remote control for power On/Off switching is convenient for everyday operation. However, in case of a longer absence or if the unit is not to be used for an extended period, set the Power switch on the unit to "Off".

FM/AM Broadcast Reception

Set the Listen Monitor selector to "Tuner" and choose the automatic or manual tuning mode with the Tuning Mode selector.

■ Automatic Tuning

- (1) Select automatic tuning with the Tuning Mode selector (Auto indicator lights up).
- (2) Choose the desired frequency band with the FM/AM Band selector.
- (3) If the desired station broadcasts on a higher frequency than currently shown on the frequency display, press the " ^ " (Up) Tuning button, otherwise the " v " (Down) button.
- (4) The tuner amplifier automatically searches for the next available station and locks onto its frequency. The Lock indicator then comes on. However, with very weak stations, the Lock in-

dicator may not light. If an FM stereo broadcast is being received, the Stereo indicator also lights up.

- (5) If the received station is not the desired one, press the Tuning button again. The frequency lock is released and the seek function resumes.
- When the unit reaches its upper reception limit, the seek direction is reversed and tuning continues towards lower frequencies. In the same way, seek tuning direction is also reversed at the lower limit. In some cases, such as when seek tuning was activated after a station close

to the reception limit was received, the unit may stop at the upper or lower limit. To restart the seek function, press the opposite-direction Tuning button.

- During FM or AM seek tuning, the muting function is always activated to suppress interstation noise.
- If an FM stereo broadcast sounds excessively noisy, pressing the Tuning Mode selector to set the unit to monaural reception (manual tuning mode) may help to make the signal more listenable.

■ Manual Tuning

When wishing to receive weak broadcast stations which are below the threshold of the automatic seek function, perform manual tuning as follows.

- (1) Select manual tuning with the Tuning Mode selector. The Auto indicator goes out, reception is switched to monaural, and FM muting is defeated.

- (2) Choose the desired frequency band with the FM/AM Band selector.

- (3) Use the Tuning buttons to adjust the receiver to the desired frequency. When a station is tuned in exactly, the Lock indicator comes on. However, with very weak stations, the Lock indicator may not light.

- When the upper or lower reception limit is reached, the frequency readout does not change any further even if the Tuning button is kept depressed. In such a case, press the opposite button.

■ Memory Tuning

This tuner amplifier incorporates two kinds of memory functions.

1. Preset Station Memory

A total of 10 FM/AM stations can be programmed at random for instant recall. To store a station into the Preset Station buttons, proceed as follows.

- (1) Tune to the desired broadcast station.
- (2) Press the Memory button. The Memory indicator lights up for about 5 seconds.
- (3) While the indicator is lit, press the desired Preset Station button. The Memory indicator

goes out and the indicator above the selected Preset Station button comes on, showing that the station has been stored. To check whether programming was correct, tune to another station, then press the previous button again and verify that the desired station is received.

- (4) When wishing to store more than 5 stations with the TA-3/TA-2, press the Shift button after the Memory button to switch to the "6-10"

range. Then press the desired Preset Station button to select one of the numbers "6" through "10."

- (5) To call up a memorized station after switching the unit on, just press the respective Preset Station button, or the Shift button and then the Preset Station button with the TA-3/TA-2.

- To change the memory content of a Preset Station button, simply perform the above steps (1)–(4) for the new station.
- If two Preset Station buttons are pressed simultaneously, the button with the lower number is given priority.
- When a Preset Station button is pressed after manual tuning was performed, the unit automatically switches to the Auto tuning mode (Auto indicator lights), to permit stereo reception (Stereo indicator lights if a stereo broadcast is received).
- If a very weak station (which can be received only with manual tuning) has been programmed into a Preset Station button, the output may be

muted when the respective button is pressed. In such a case, switch the unit back to the manual tuning mode with the Tuning Mode selector.

2. Last Station Memory

This unit's last station memory operates in two ways.

- (1) When the frequency band is changed with the AM/FM Band selector, the last station received in each band is memorized. Therefore when switching back to a band, the unit automatically reverts to the previous station.
- (2) The station received immediately before the power was turned off is also memorized. When

power is switched on again, the unit will be tuned to this station. This also applies if power is supplied via an external timer.

This unit possesses a built-in lithium battery for memory backup. The contents of the preset station memory and the last station memory will be preserved for about five years even if the AC cord of the unit is unplugged. For replacement of the lithium battery, contact your dealer. Never perform the replacement yourself, as this may lead to damage of the unit.

Phono Playback

Set the Listen Monitor to "Phono" and the Tape Monitor switch to "Source." Then operate the turntable. After the stylus was lowered onto the record, turn up the Volume control of this unit to obtain the desired listening level. If required, adjust the tonal and left/right balance with the controls of the tuner amplifier.

- To protect the loudspeakers from possible damage, always turn the Volume control fully to minimum when lowering or lifting the stylus.
- For phono playback, the subsonic filter should normally be set to "On" (TA-4/TA-3). The TA-2 incorporates a built-in subsonic filter in the phono circuit, which automatically removes harmful low-frequency noise.

■ Matching the Unit to the Type of Phono Cartridge

The TA-3 and TA-2 are designed for moving-magnet type cartridges only. The TA-4 can accommodate both moving-magnet and moving-coil cartridges. Set the Cartridge selector on the front panel of the TA-4 to the correct position for the cartridge in use ("MM" for moving-magnet types and "MC" for moving-coil types.). For MM cartridges, this is the only adjustment required. For MC cartridges, the gain of the phono stage may be adjusted with the MC Gain selector on the rear panel. (Refer to the chart.) High-output MC cartridges with rated outputs of more than 1.0 mV should be used at the MM position. (The rated output is listed in the specification sheet of the cartridge.)

Rated cartridge output	MC Gain selector
Less than 0.2 mV	32 dB
0.2 ~ 1.0 mV	24 dB
More than 1.0 mV	Set Cartridge selector to "MM."

Always turn the Volume control fully to minimum before operating the Cartridge selector or the MC Gain selector, to protect the loudspeakers from possible damage by switching "thumps."

Listening to a CD Player or Other Audio Program Sources

To listen to a CD player or to other audio components, set the Listen Monitor selector to the required position. Then operate the source equipment and adjust the desired volume level and balance at the tuner amplifier.

Recording and Playback With a Tape Deck

■ Playback

Set the Listen Monitor selector to the required tape position.

Set the tape deck to the playback mode and adjust the desired volume level and balance at the tuner amplifier.

■ Recording

Set the Listen Monitor selector to the program source you wish to record and set the tape deck to the recording mode.

If the connected tape deck possesses three heads and monitoring capability, the quality of the actual recorded signal can be checked by setting the Listen Monitor selector of the tuner amplifier to the respective tape position.

- As the same signal from the program source is supplied at all audio output terminals of the TA-4/TA-3, recording can also be carried out on several tape decks simultaneously.
- The signal supplied to the tape output terminals is completely unaffected by the volume and balance settings of the tuner amplifier.

■ Tape Dubbing

The TA-4 and TA-3 have multiple pairs of tape input and output jacks. By connecting two tape decks (up to three tape decks in case of the TA-4) to these jacks, tape dubbing in all directions can be carried out easily.

For example, to paly back a tape on tape deck 1 and record it on the other tape deck(s), set the Rec Out selector to "1▶2,3 Copy" (TA-4) or to "1▶2 Copy" (TA-3). For dubbing in other directions, choose the appropriate position.

With the TA-2, tape dubbing can be carried out by connecting the source tape deck to the Video (Aux) input terminals. Set the Rec Out selector to "Video" and record on the tape deck connected to the regular tape deck jacks.

- The signal supplied to the tape input terminals of the tape recorder during dubbing is completely unaffected by the volume and balance settings of the tuner amplifier.

Recording and Playback With A/V Equipment (TA-4/TA-3)

The TA-4/TA-3 permit connection and switching of audio-visual components, so that the unit can be used as an A/V control center.

These models have two sets of inputs for connections from stereo A/V sources ("Video 1," "Video 2") and one set of input/output terminals for connections with a stereo video recorder.

Both models provide a separate video output ("Video Monitor") for connection of a color monitor for high-quality viewing.

The possibilities afforded by this system are wide and varied.

■ Playback

Set the Listen Monitor selector to the position for the audio-visual source component. Set the TV or monitor to the video input mode to view the picture. Start playback with the audio-visual component and adjust volume and tonal balance with the controls of the tuner amplifier.

■ Recording (Dubbing)

Set the Rec Out to "Video 1" or "Video 2," depending on the source to be used. Then set the A/V source to the playback mode and the VCR to the recording mode. It is possible to monitor the video signal on a connected TV or color monitor while dubbing is carried out.

- The audio and video signal supplied to the VCR is completely unaffected by the volume and balance settings of the tuner amplifier.

Rec Out and Listen Monitor Selectors

The Rec Out selector and Listen Monitor selector of this unit operate completely independent of each other.

For example, you can listen to a broadcast while recording the sound of a CD player on a tape deck, or you might carry out tape dubbing while listening to a CD. It is also possible to set the Listen Monitor selector to an audio-output position such as CD and the Rec Out selector to a video output position for monitoring a video signal on a connected TV. This lets you for example watch a videodisc while supplying the music from a CD player. Please refer to the signal flow table below to explore the various system possibilities.

■ Signal Flow Table (TA-4/TA-3)

(The chart shows the signal flow for the TA-4. For the TA-3, disregard "Tape 2" and read "Tape 2/VCR" for "Tape 3/VCR.")

Listen Monitor selector	Rec Out selector	Audio Signal				Video Signal	
		Speaker Terminals	Tape 1 Record (Output) Terminals	Tape 2 Record (Output) Terminals	Tape 3/VCR Record (Output) Terminals	Video Monitor Terminals	Tape 3/VCR Record (Output) Terminals
Phono/Tuner/CD/ Tape 1/Tape 2	Phono	*Phono/Tuner/CD/ Tape 1/Tape 2	Phono	Phono	Phono	—	—
	Tuner	"	Tuner	Tuner	Tuner	—	—
	CD	"	CD	CD	CD	—	—
	Video 1	"	Video 1	Video 1	Video 1	Video 1	Video 1
	Video 2	"	Video 2	Video 2	Video 2	Video 2	Video 2
	1 ▶ 2,3 Copy	"	—	Tape 1	Tape 1	—	—
	2 ▶ 1,3 Copy	"	Tape 2	—	Tape 2	—	—
	3 ▶ 1,2 copy	"	Tape 3/VCR	Tape 3/VCR	—	Tape 3/VCR	—
	Off	"	—	—	—	—	—
Video 1/Video 2/ Tape 3 /VCR	Phono	*Video 1/Video 2/ Tape 3 /VCR	Phono	Phono	Phono	*Video 1/Video 2/ Tape 3 /VCR	—
	Tuner	"	Tuner	Tuner	Tuner	"	—
	CD	"	CD	CD	CD	"	—
	Video 1	"	Video 1	Video 1	Video 1	"	Video 1
	Video 2	"	Video 2	Video 2	Video 2	"	Video 2
	1 ▶ 2,3 Copy	"	—	Tape 1	Tape 1	"	—
	2 ▶ 1,3 Copy	"	Tape 2	—	Tape 2	"	—
	3 ▶ 1,2 copy	"	Tape 3/VCR	Tape 3/VCR	—	"	—
	Off	"	—	—	—	"	—

★ : The signal from the program source selected with the Listen Monitor selector is supplied.
 — : No output.

Use of the Wireless Remote Control Unit

The wireless remote control unit supplied with the unit permits power On/Off switching, Listen Monitor selection, volume adjustment and Mute On/Off operation of the tuner amplifier, and it can also be used to control basic functions of other Nakamichi

components equipped for System Remote control. (For a list of cassette decks and functions which can be operated, please refer to page 20.) To use the remote control, leave the Power switches of the tuner amplifier and the other components set to

“On” and point the infrared transmitter window towards the remote control sensor on the unit. When the remote control is operated, the remote control sensor indicator of the tuner amplifier light up.

■ Controls and Functions

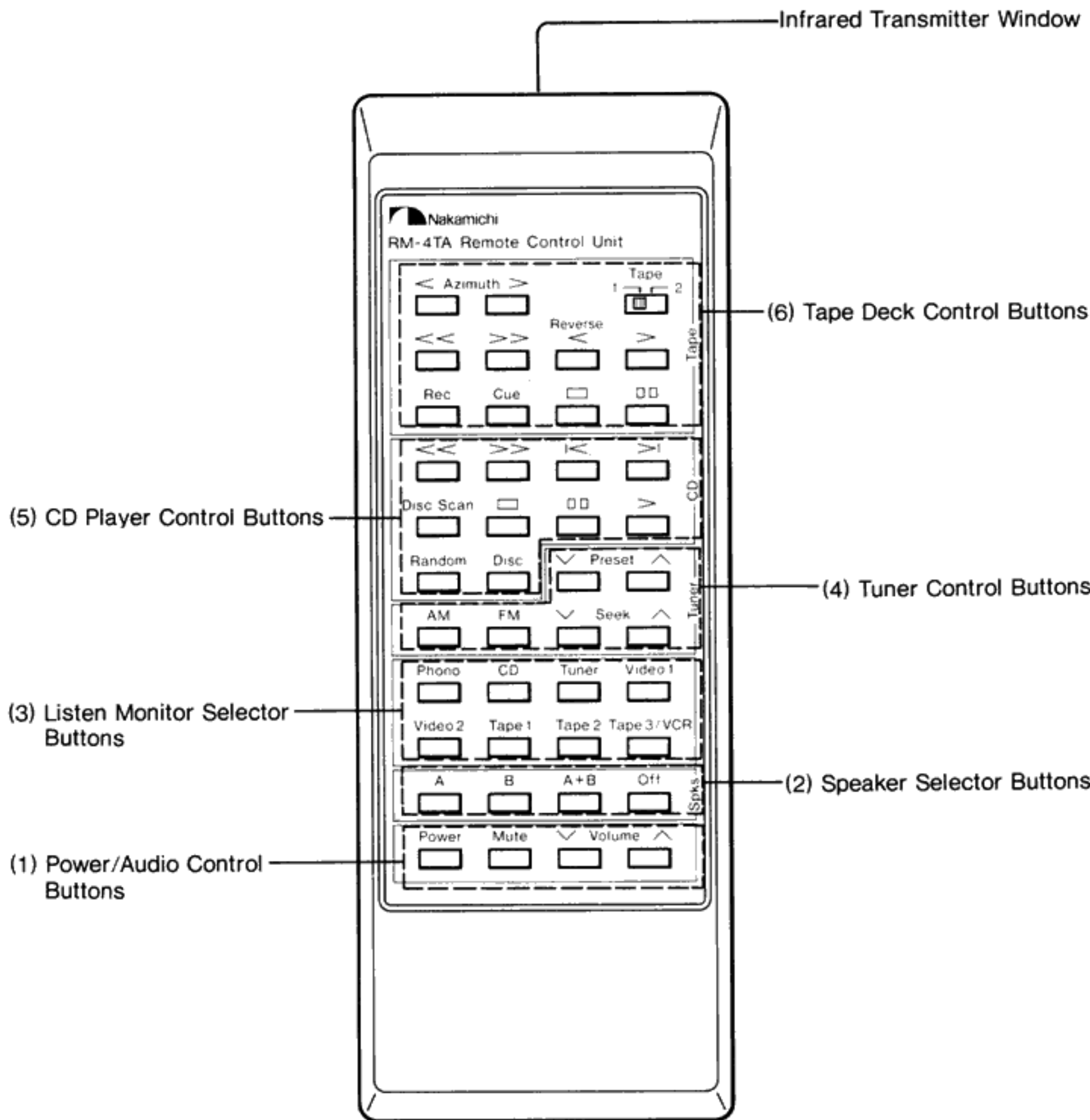

The illustration shows the remote control RM-4TA supplied with the TA-4.

(1) Power/Audio Control Buttons

◆ Power On/Off Button

Pressing this button toggles the unit between “On” and the standby mode.

◆ Mute Button

Pressing the button once activates audio muting, and pressing the button once more restores the normal volume setting.

◆ ∨ Volume ∧ (Up/Down) Buttons

These buttons permit adjustment of the listening level. When the “∧” button is pressed while audio muting is activated, the muting condition is automatically released and the volume is raised.

(2) Speaker Selector Buttons (TA-4)

(To use these buttons, set the Speaker selector on the main unit to “Remote.”)

◆ A, B, A+B, Off

With these buttons, the desired loudspeakers can be selected. When wishing to listen with headphones only, press the “Off” button.

(3) Listen Monitor Selector Buttons

◆ **Phono, CD, Tuner, Video 1, Video 2, (TA-2: Video), Tape 1, Tape 2, (TA-3: Tape 2/VCR, TA-2: Tape), Tape 3/VCR (TA-4 only)** By pressing one of these buttons, the desired program source can be chosen.

When the unit is in the standby mode, operating one of these selectors will activate the unit and the selected source can be heard (direct operation).

(4) Tuner Control Buttons

◆ FM, AM Band Selector Buttons

The desired frequency band can be selected with these buttons.

◆ ∨ Seek ∧ Buttons

These buttons initiate the automatic tuning function.

◆ ∨ Preset ∧ (Preset Station) Buttons

With these buttons, stations stored in the preset station memory can be selected. When station “1” or “10” is reached and a button is kept depressed, the tuning does not change further. Press the opposite button to continue cycling through stored stations.

(5) CD Player Control Buttons

- ◆ **□ (Stop) Button**
Pressing this button during playback or in the pause mode cancels the present operation and returns the CD player to the standby mode.
- ◆ **□ □ (Pause) Button**
Press this button to temporarily interrupt playback.
- ◆ **> (Play) Button**
Press this button to start playback or to resume playback from the pause mode.
- ◆ **<< (Reverse) Button**
Serves to rapidly move the laser pickup in the reverse direction. Pressing the button during playback permits reverse cueing.
- ◆ **>> (Fast Forward) Button**
Serves to rapidly move the laser pickup in the forward direction. Pressing the button during playback permits forward cueing.
- ◆ **⏮ (Reverse Skip) Button**
This button can be used to skip to the start of the present or an earlier track.
- ◆ **⏭ (Forward Skip) Button**
This button can be used to skip to the start of a later track.
- ◆ **Random (for CDC-4/CDC-3 only)**
When this button is pressed while the CDC-4/CDC-3 player is in the standby mode, tracks from all discs are played in random order. If the button is pressed after a disc was selected, tracks from that disc are played in random order.

- ◆ **Disc Scan (for CDC-4/CDC-3 only)**
The beginning of the first track on every disc in the CDC-4/CDC-3 is played for ten seconds when this button is pressed.
- ◆ **Disc (for CDC-4/CDC-3 only)**
This button serves to select a disc inserted in the CDC-4/CDC-3. With each push of the button, the player cycles through discs 1→2→... 6→1→2 etc.
- The operation of the buttons is identical to the controls on the CD player. For detailed instructions, please refer to the Owner's Manual of the CD player.

(6) Tape Deck Control Buttons

- ◆ **< Azimuth > Adjustment Buttons (TA-4/TA-3)**
These buttons are used for fine adjustment of playback head azimuth with the Nakamichi CR-7A cassette deck.
- ◆ **Tape 1/Tape 2 Selector Switch (TA-4/TA-3)**
This switch determines which of the connected cassette decks is to be remote-controlled.
- ◆ **<< (Rewind) Button**
Serves to rewind the tape.
- ◆ **>> (Fast Forward) Button**
Serves to fast-forward the tape.
- ◆ **Reverse**
- ◆ **< Button**
With the DRAGON cassette deck, this button functions as the Reverse Play button. With a cassette deck of the RX series, it functions as Direction Reversal button.

- ◆ **> (Play) Button**
This button initiates tape playback or starts recording from the recording standby mode.
- ◆ **Rec Button**
Serves to set the tape deck to the recording mode. (With some models, pressing this button once more during recording activates the Rec Mute function. Refer to the chart on the next page.)
- ◆ **Cue Button**
This button serves for cueing. (On decks without cueing capability, the button initiates fast-forward or stop. Refer to the chart on the next page.)
- ◆ **□ (Stop) Button**
Pressing this button terminates the present mode and stops the tape.
- ◆ **□ □ (Pause) Button**
This button is used to temporarily interrupt tape travel during recording or playback. To restart the tape, press the Play button once more.
- The operation of the buttons is almost identical to the controls on the tape deck. For detailed instructions, please refer to the Owner's Manual of the tape deck.
For a list of models which can be used with the remote control and functions which can be operated, please refer to the chart on the next page.

■ Batteries

Remove the cover of the battery compartment as shown in the illustration and insert the supplied two IEC R6 batteries (size AA) into the compartment, taking care to observe correct polarity. When the batteries are nearing exhaustion, the effective range of the remote control decreases or the remote control may fail to operate. In this case, **replace both batteries with fresh ones.** (A good indication that the batteries need replacing is when the indicator on the remote control begins to grow dim.)

Note:

- Do not use a mixture of old and new batteries, and make sure that both batteries are of the same type.
- Only batteries specially designed and clearly marked as such are rechargeable. Carefully read and observe the instructions printed on the batteries.

- To prevent damage caused by possible battery leakage, remove the batteries from the remote control unit if it is not to be used for an extended period of time.

- Never dismantle batteries or dispose of them in fire, as they may explode. Dispose of batteries only in an appropriate way as indicated by your community.

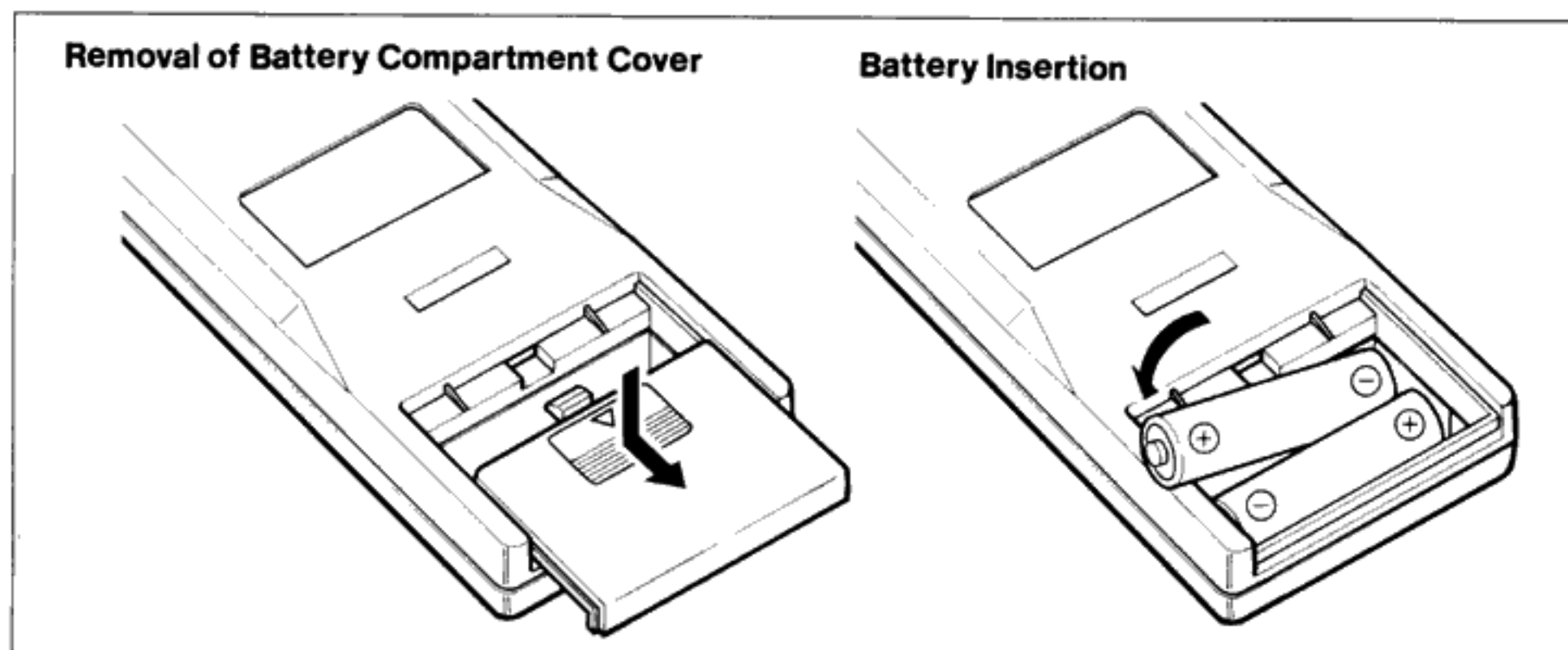

■ Tape Deck Operation Chart

Remote control button Tape deck model	<<	>>	Reverse <	>	Rec	Cue	□	□ □	<Azimuth>
CR-7	Rewind	Fast-Forward	—	Play	Record* Standby	Fast-Forward	Stop	Pause	Azimuth Fine Tuning
CR-5	"	"	—	"	**	"	"	"	—
CR-4/CR-3/CR-2	"	"	—	"	"	"	"	"	—
1000ZXL	"	"	—	"	Record*	Cueing	"	"	—
DRAGON	"	"	Reverse- Direction Play	Forward- Direction Play	**	"	"	"	—
RX-505	Fast-Forward	Rewind	Tape Direction Reversal	Play	**	"	"	"	—
RX-303	"	"	"	"	**	Fast-Forward	"	"	—
ZX-5	Rewind	Fast-Forward	—	"	Record* Standby	Stop	"	"	—
1000/1000II*	"	"	—	"	Record	Fast-Forward	"	"	—
700/700II*	"	"	—	"	"	"	"	"	—
700ZXL/700ZXE	"	"	—	"	**	Cueing	"	"	—
ZX-9/ZX-7	"	"	—	"	"	"	"	"	—
LX-5/LX-3	"	"	—	"	"	Fast-Forward	"	"	—
682ZX/681ZX/680ZX/680	"	"	—	"	**	Cueing	"	"	—
670ZX/660ZX	"	"	—	"	**	"	"	"	—
582Z/581Z	"	"	—	"	**	"	"	"	—
582/581/580M/580	"	"	—	"	"	"	"	"	—

— : Not available.

" : As above.

* : When Rec button is pressed again during recording, Record Mute is activated.

* : Optional Tape Deck Control cable SRC-3 for the models 1000/1000II/700/700II required.

Troubleshooting

	Condition	Probable Cause	Remedy
Audio Section	No power.	1. Power cord not plugged properly into AC wall outlet.	1. Plug in power cord firmly.
	No sound.	2. Faulty connections of RCA-type plugs, shielded cables between components, or speaker cables. 3. Listen Monitor selector not set correctly. 4. Protection circuits are activated. 5. Nothing connected to the Pre Output/Main Input terminals.	2. Check connections. 3. Select correct positions. 4. Refer to the paragraph "Protection Circuits" on page 13. 5. If a sound processor equipment is to be used, the jumper plugs must be inserted in the jacks.
	Left/right channels reversed, no sound from one channel.	6. Faulty connections of RCA-type plugs, shielded cables between components, or speaker cables. 7. Balance control turned fully to one side.	6. Check connections. 7. Adjust Balance control.
	Bass response deficient, unstable stereo imaging.	8. Speaker cable connected with reversed (+) (-) polarity in one channel.	8. Connect speaker cable correctly.
	Hum noise is heard during record playback.	9. Faulty or incomplete connection of RCA-type plugs. 10. Faulty or incomplete connection of ground cable. 11. Output cable from turntable routed too close to AC power cord. 12. Unit is placed too close to turntable and cartridge.	9. Insert plugs firmly. 10. Check ground connection. 11. Route AC power lines as far as possible from output cables and cartridge. 12. Increase distance between unit and cartridge.
	Low volume levels when using moving-coil cartridge.(TA-4)	13. Moving-coil cartridge is used at "MM" position. 14. Gain setting is incorrect.	13. Set Cartridge selector to "MC." 14. Select proper setting of the MC Gain selector for cartridge in use (→page 16).
	Hum noise is heard.	15. Faulty or incomplete connection of RCA-type plugs. 16. Unit is placed too close to a TV set.	15. Insert plugs firmly. 16. Increase distance between unit and TV set.
Tuner Section	General	Desired station not received when Preset Station button is pushed.	17. Station not stored correctly in the memory. 17. Store station as described in "Memory Tuning" on page 15.
		Auto tuning not possible.	18. Insufficient antenna signal. 18. Change antenna height or orientation, or use a multiple-element FM antenna.
	FM Reception	Noise level increases notably when stereo broadcasts are received.	19. Insufficient antenna signal. 19. Change antenna height or orientation, or use a multiple-element FM antenna.
		Intermittent crackling noise.	20. Interference caused by ignition systems of cars etc. 20. Remove antenna as far as possible from roads etc. Use a 75-ohm coaxial cable for antenna connection.
		Broadcast is supposed to be in stereo, but Stereo indicator does not light and sound is monaural.	21. Mode selector set to manual tuning. 21. Set selector to Auto tuning.
	AM Reception	Buzzing noise.	22. Interference caused by fluorescent lights, motors or thermostats of electrical appliances etc. 22. Using an outdoor wire antenna and ground connection may reduce noise (complete removal is sometimes not possible).
Chirping noise.		23. Interference from adjacent stations. 24. Interference from a TV set. 23. Reorient loop antenna. 24. Increase distance between receiver and TV set.	
A/V Section	No picture or sound. (TA-4/TA-3)	25. Faulty connections. 26. Listen Monitor selector or Rec Out selector set to incorrect position.	25. Check connections. 26. Refer to the signal flow table on page 17 to determine the correct position for all switches.
Others	Remote control does not operate.	27. Power switch of the tuner amplifier is set to "Off." 28. Batteries are inserted with wrong polarity. 29. Batteries are exhausted. 30. Remote control unit is outside of effective range. 31. An obstacle is placed between remote control and the tuner amplifier. 32. Another wireless remote control is operated at the same time.	27. Set Power switch to "On." 28. Insert batteries correctly. 29. Replace both batteries with fresh ones. 30. Operate unit within effective range. 31. Remove obstacle. 32. Avoid simultaneous use of several remote control devices.

Specifications

Power Amplifier Section

Note: Unless noted otherwise, specifications are in accordance with IHF-A-202 measured from any high-level input (CD/VIDEO/TAPE) to the speaker output.

	TA-4	TA-3	TA-2
Continuous Average Output Power	100 watts per channel into 8 ohms, both channels driven, 20—20,000 Hz, at no greater than 0.1% THD	75 watts per channel into 8 ohms, both channels driven, 20—20,000 Hz, at no greater than 0.1% THD	50 watts per channel into 8 ohms, both channels driven, 20—20,000 Hz, at no greater than 0.1% THD
Dynamic Output Power	132 watts per channel into 8 ohms 167 watts per channel into 4 ohms	100 watts per channel into 8 ohms 125 watts per channel into 4 ohms	66 watts per channel into 8 ohms 80 watts per channel into 4 ohms
Power Bandwidth	5—60,000 Hz	5—50,000 Hz	5—50,000 Hz
Frequency Response	20—20,000 Hz; +0, -0.5 dB 5—85,000 Hz; +0, -3 dB	20—20,000 Hz; +0, -0.5 dB 5—75,000 Hz; +0, -3 dB	20—20,000 Hz; +0, -0.5 dB 5—75,000 Hz; +0, -3 dB
Signal-to-Noise Ratio (A-WTD, input shorted)	Better than 100 dB re rated power Better than 83 dB (IHF-A-202)	Better than 100 dB re rated power Better than 83 dB (IHF-A-202)	Better than 100 dB re rated power Better than 83 dB (IHF-A-202)
Total Harmonic Distortion (8 ohms, rated power, 20 Hz—20 kHz)	Less than 0.1%	Less than 0.1%	Less than 0.1%
Headphone Rated Output (40 ohms)	234 mW	175 mW	117 mW
Output Current Capability	28 A peak per channel	18 A peak per channel	14 A peak per channel

Preamplifier Section

Note: Unless noted otherwise, specifications are in accordance with IHF-A-202. Except for sensitivity, S/N, tone control and loudness characteristics (which are measured to the speaker outputs), measurements are made from the specified input to Rec Out.

	TA-4	TA-3	TA-2
Sensitivity (for rated output)			
Phono MC (gain: 32/24 dB)	60/160 μ V	—	—
Phono MM	2.5mV	2.5 mV	2.5 mV
CD/Tape/Video	150 mV	150 mV	150 mV
Main in	1.0V	1.0 V	1.0 V
Sensitivity (for 1-watt output, IHF-A-202)			
Phono MC (gain: 32/24 dB)	6.0/16 μ V	—	—
Phono MM	0.25 mV	0.29 mV	0.35 mV
CD/Tape/Video	15 mV	17 mV	21 mV
Main in	100 mV	115 mV	141 mV
Input Impedance			
Phono MC	100 ohms	—	—
Phono MM	47 kohms	47 kohms	47 kohms
CD/Tape/Video	20 kohms	20 kohms	20 kohms
Main in	15 kohms	20 kohms	20 kohms
Maximum Input Level (1 kHz)			
Phono MC (gain: 32/24 dB)	4.0/10 mV	—	—
Phono MM	180 mV	180 mV	180 mV
Pre Output Level/Impedance	1.0V/1 kohms	1.0V/1 kohms	1.0V/1 kohms
Record Output Level/Impedance	150 mV/1.5 kohms	150 mV/1.5 kohms	150 mV/1.5 kohms
Total Harmonic Distortion (1 kHz, to Rec Out, at 1 V)			
Phono MC	Less than 0.007% (either gain)	—	—
Phono MM	Less than 0.005%	Less than 0.008%	Less than 0.01%
RIAA Deviation			
Phono MC	30—20,000 Hz \pm 0.5 dB	—	—
Phono MM	30—20,000 Hz \pm 0.5 dB	30—20,000 Hz \pm 0.5 dB	30—20,000 Hz \pm 0.5 dB
Signal-to-Noise Ratio (to speaker output, IHF-A-202)			
Phono MC	Better than 70 dB (either gain)	—	—
Phono MM	Better than 78 dB	Better than 78 dB	Better than 78 dB
Tone Controls			
Bass	20 Hz, \pm 10 dB	20 Hz, \pm 10 dB	20 Hz, \pm 10 dB
Treble	20 kHz, \pm 10 dB	20 kHz, \pm 10 dB	20 kHz, \pm 10 dB
Variable Loudness (re maximum attenuation: -40 dB at 1 kHz)	20 Hz, +20 dB; 20 kHz, +6 dB	20 Hz, +20 dB; 20 kHz, +6 dB	20 Hz, +20 dB; 20 kHz, +6 dB
Subsonic Filter (Phono only)	Cutoff Frequency 20 Hz, -12 dB/octave	Cutoff Frequency 20 Hz, -12 dB/octave	—

Tuner Section

[FM] **Note:** All RF levels in microvolts given re 300-ohm antenna input.
 Modulation: Mono 100%, Stereo Pilot 9%, Stereo Audio Signal 91%.
 All measurements made at Rec Out jack.

	TA-4	TA-3	TA-2
Frequency Range	87.5—108.0 MHz in 100 kHz steps	87.5—108.0 MHz in 100 kHz steps	87.5—108.0 MHz in 100 kHz steps
IHF Usable Sensitivity (Mono)	11 dBf/1.9 μ V	11 dBf/1.9 μ V	12 dBf/2.2 μ V
50-dB Quieting Sensitivity			
Mono	14.7 dBf/3.0 μ V	14.7 dBf/3.0 μ V	15.7 dBf/3.3 μ V
Stereo	37.5 dBf/41.1 μ V	37.5 dBf/41.1 μ V	38.5 dBf/46.1 μ V
Signal-to-Noise Ratio at 65 dBf			
Mono	Better than 82 dB	Better than 79 dB	Better than 79 dB
Stereo	Better than 75 dB	Better than 74 dB	Better than 74 dB
Muting Threshold	30 dBf/17.3 μ V	30 dBf/17.3 μ V	30 dBf/17.3 μ V
Frequency Response	20—15,000 Hz \pm 1 dB	20—15,000 Hz \pm 1 dB	20—15,000 Hz \pm 1 dB
Total Harmonic Distortion (1 kHz)			
Mono	Less than 0.07%	Less than 0.07%	Less than 0.1%
Stereo	Less than 0.07%	Less than 0.07%	Less than 0.1%
Capture Ratio	2.0 dB	2.0 dB	2.0 dB
Alternate Channel Selectivity	65 dB (\pm 400 kHz)	55 dB (\pm 400 kHz)	55 dB (\pm 400 kHz)
Stereo Separation at 1 kHz	Better than 50 dB	Better than 50 dB	Better than 50 dB
Spurious Response Rejection	Better than 90 dB	Better than 90 dB	Better than 90 dB
Image Rejection	Better than 75 dB	Better than 75 dB	Better than 75 dB
IF Rejection	Better than 80 dB	Better than 80 dB	Better than 80 dB
AM Suppression	Better than 60 dB	Better than 60 dB	Better than 60 dB

[AM] **Note:** Modulation—400 Hz, 30%

	TA-4	TA-3	TA-2
Frequency Range	520 kHz—1,710 kHz in 10 kHz steps	520 kHz—1,710 kHz in 10 kHz steps	520 kHz—1,710 kHz in 10 kHz steps
Sensitivity	53 dB μ /m	53 dB μ /m	53 dB μ /m
Signal-to-Noise Ratio at 90 dB μ /m	Better than 52 dB	Better than 52 dB	Better than 52 dB
Total Harmonic Distortion at 90 dB μ /m	Less than 0.5%	Less than 0.5%	Less than 0.5%
Selectivity	Better than 20 dB (\pm 10 kHz)	Better than 20 dB (\pm 10 kHz)	Better than 20 dB (\pm 10 kHz)

General

	TA-4	TA-3	TA-2
Power Source	120, 220 or 240 V AC, 50/60 Hz (According to country of sale)	120, 220 or 240 V AC, 50/60 Hz (According to country of sale)	120, 220 or 240 V AC, 50/60 Hz (According to country of sale)
Power Consumption	425 W max.	350 W max.	290 W max.
Convenience Outlets	Switched: 2, Unswitched: 1	Switched: 2	Switched: 2
Dimensions*	430(W) \times 125(H) \times 370(D) mm 16-15/16(W) \times 4-15/16(H) \times 14-9/16(D) inches	430(W) \times 100(H) \times 370(D) mm 16-15/16(W) \times 3-15/16(H) \times 14-9/16(D) inches	430(W) \times 100(H) \times 370(D) mm 16-15/16(W) \times 3-15/16(H) \times 14-9/16(D) inches
Approximate Weight	15.0 kg 33 lbs. 1 oz.	11.0 kg 24 lbs. 4 oz.	8.6 kg 18 lbs. 15 oz.

<Remote Control Unit>	TA-4<RM-4TA>	TA-3<RM-3TA>	TA-2<RM-2TA>
Principle	Infrared pulse system	Infrared pulse system	Infrared pulse system
Power Supply	3 V DC (1.5 V \times 2)	3 V DC (1.5 V \times 2)	3 V DC (1.5 V \times 2)
Dimensions*	64(W) \times 18(H) \times 176(D) mm 2-1/2(W) \times 11/16(H) \times 6-15/16(D) inches	64(W) \times 18(H) \times 176(D) mm 2-1/2(W) \times 11/16(H) \times 6-15/16(D) inches	64(W) \times 18(H) \times 176(D) mm 2-1/2(W) \times 11/16(H) \times 6-15/16(D) inches
Approximate Weight	140 g 5 oz. (including batteries)	140 g 5 oz. (including batteries)	140 g 5 oz. (including batteries)

- *: Dimensions do not include protruding parts. Height is the panel height without feet.
- Specifications and design are subject to change for further improvement without notice.
 - STASIS manufactured under license from Threshold Corporation.
 - STASIS is a trademark of Threshold Corporation.

Nakamichi Corporation/Tokyo Office
Nakamichi America Corporation
Nakamichi Canada
Nakamichi GmbH
Nakamichi Australia

Shinjuku Daiichi Seimei Bldg., 2-7-1 Nishishinjuku, Shinjuku-ku, Tokyo 163 Phone: (03) 342-4461 Telex: 2324721 (NAKAM J)
19701 South Vermont Ave., Torrance, CA 90502 Phone: (213) 538-8150
276 South West, Marine Drive, Vancouver, B.C. V5X 2R4 Phone: (604) 324-7535
Stephanienstrasse 6, 4000 Düsseldorf 1 Phone: (0211) 359036
Unit 10, 21-29 Chester Street, Camperdown, N.S.W. 2050 Phone: (02) 519-3977