

# TDS-2010H MOUNTING INSTRUCTIONS

The **TDS-2010H** is designed to be mounted on Trailers with a front wall height or mounting area of at least 48" tall. There must also be at least 20" of width and 14" in depth (at the top of the Trailer) for the unit to fit properly.

**⚠ CAUTION: Installation on Trailers with front wall heights of less than 48" is not recommended because the lower drive portion of the unit WILL NOT have adequate ground clearance during Trailer transportation. The recommended 48" will result in the track portion of the unit extending 5" below the bottom of the Trailer when fully retracted and in the "Travel Position".**

The **TDS-2010H** model is designed to bolt to the 4" wide "C" channel commonly found at the center of the front wall of many "gooseneck" Trailers. This "C" channel is where the conventional jacking devices have been mounted in the past.

There must also be adequate space on the front wall of the Trailer to mount the electrical control box. The preferred location is to the right of the unit near the top of the wall. Select a clear area just to the right of the "C" channel that is at least 24" wide x 14" high. Keep in mind that the handheld control box cable will connect to the right hand side of the main electrical box. It will be connected and disconnected each time the unit is used so be sure that the connector is easily assessable.

**Note:** "Right" or "Left" as used in the following instructions may be determined by standing beside the Trailer and facing the direction of the vehicle used to tow the Trailer.

**Note:** "UP" or "DOWN" as used in the following instructions refers to Raising or Lowering the front of the Trailer (the cylinder extends to Raise the Trailer, and retracts to Lower the Trailer).

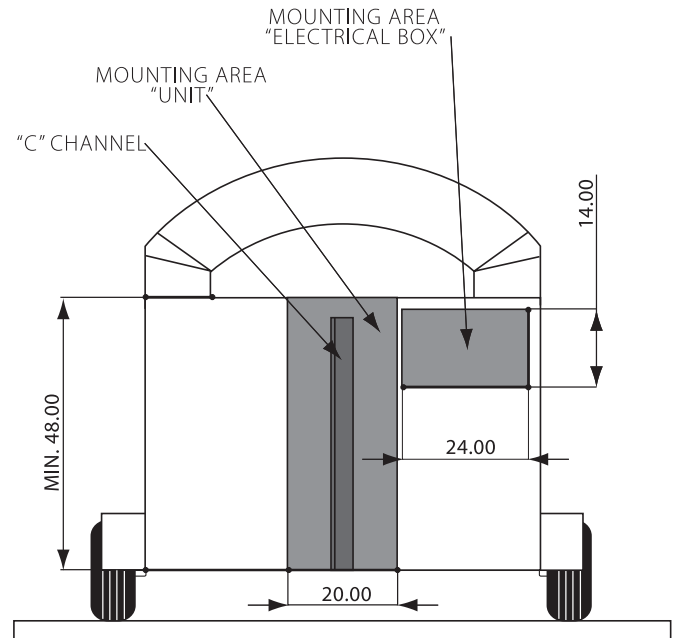

## INSTALLATION PROCEDURES

Locate all parts and necessary tools.

Jack the Trailer up so that its bottom edge at the front wall is approximately 16" above the ground and support the Trailer with suitable jack stands.

Remove the existing jacking device, if any.

Measuring from the front wall's bottom edge (not the ground), mark and drill a 17/32" hole in each side of the "C" channel 43-3/4" from the bottom of the Trailer and 3/4" from the face of the Trailer.

Mount the spring anchor brackets. The ideal location for the brackets is on the backside of horizontal beam that supports the bottom edge of the front wall. Place the brackets 2-4 inches apart, centered between the left and right sides of the Trailer. Use the brackets as a guide and drill two 11/32" holes for each bracket. Secure with the 5/16 x 1 inch bolts, nuts and lock washers provided. Tighten to 15 ft. lbs.

Using a suitable lifting device, carefully stand the unit upright and maneuver it into position over the "C" channel. Raise or lower the unit as necessary to align the top mounting holes in the side plate of the unit with the holes drilled in step # 4. Secure the unit with a 1/2-13 x 5 1/2 inch bolt, two flat washers, lock washer, and nut.

Maneuver the unit if necessary to ensure that the rear edges of the unit's side plates are flush with the wall.

Drill the remaining three (3) holes into each side of the "C" channel. Use the mounting holes at the lower back edge of the unit's side plates as locating guides.

Secure the unit with the remaining mounting hardware. Tighten all four (4) bolts to 60 ft. lbs.

Choose a location for the main electrical control box. The ideal location is on the right hand side of the upper lift assembly near the top of the Trailer wall. If this area is available, place the left hand side of the control box approximately 10 inches to the right of the upper lift assembly's mounting plate. Place the top of the control box approximately 6 inches from the top of the Trailer wall. If the aforementioned location is not available, choose an alternate location.

**Note:** Depending on the distance from the ideal mounting location to the alternate location, some power cables may need to be replaced with longer cables. It is best to keep the cables as short as possible for more efficient power transfer. Regardless of the chosen location, ensure that the connector on the right hand side of the control box has enough clear area around it to allow for easy connection and disconnection of the handheld control box.

Remove the access panel on the front of the main electrical control box and locate the four (4) mounting holes. Secure the main electrical control box to the Trailer wall with the four (4) ¼ x 1 inch self-drilling screws provided.

Using the diagram in this section, connect all cables to their appropriate locations. There is a conduit for each of the hydraulic power units, a conduit for the “extension wiring harness” (extends wires for directional valves), and a conduit for the 12 VDC power source.

Cut the set of directional valve wires approximately 6” long (length extending outside of front cover). Strip the ends of the directional valve wires and connect the two brown wires together with one of the “extension wiring harness” leads using a wire nut. Connect the two blue wires together with the other “extension wiring harness” lead using a wire nut. Secure the wire with a wire tie, strap, or clamp. Feed the loose end of the “extension wiring harness” through the upper conduit until the wires extend into the electrical box. Connect one lead of the “extension wiring harness” to the terminal block [opposite the black wire (+)] and connect the other “extension wiring harness” lead to the terminal block [opposite the yellow wire (-)]. Replace the access panel.

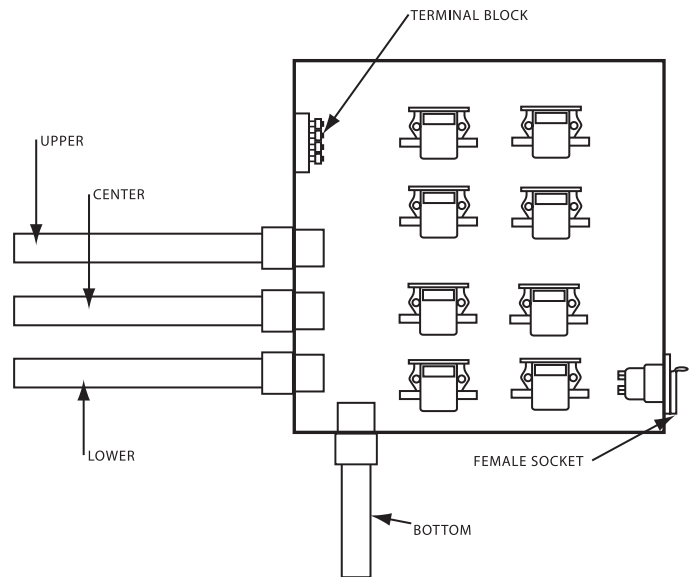

The center conduit on the side of the electrical control box contains the power cables for the Right hand hydraulic power unit. Connect the power cables to the electric motor with Red to (+) and Black to (-).

The lower conduit on the side of the electrical control box contains the power cables for the Left hand hydraulic power unit (large reservoir unit). Connect the emergency wire leads and power cables to the electric motor with Red to (+) and Black to (-). **DO NOT** connect the other end of the emergency wires, but ensure the end cap is on the connector to prevent contact with other parts.

The conduit located on the bottom of the electrical control box contains the cables to be connected to the battery(s). Connect the cables to the battery(s) with Red to (+) and Black to (-).

Fill each hydraulic power unit reservoir with Dexron III ATF. Access the reservoirs by turning the red vent caps counterclockwise. Fill the reservoirs to within ½” of the bottom of the access hole.

**Note:** Always check and fill the reservoirs while the lifting cylinder is fully retracted.

Connect the handheld control box to the main electric control box by inserting the male 6-pin connector on the end of the tether cord into the socket on the right hand side of the main electrical control box.

**Note:** The male connector has a rib that must be aligned with a key in the socket.

Purge the air from each hydraulic system. With the Trailer supported by jack stands, hold down the “PUSH TO LIFT” button with your left thumb and deflect the left toggle switch to the UP position briefly. Continue until the unit has lowered sufficiently for the tracks to unfold and clear the wall of the Trailer. Release the “PUSH TO LIFT” button and toggle switch. Once the tracks are clear of any obstacles, operate each of them for at least 15 –20 seconds in each direction or longer if necessary until they run smoothly.

**Note:** This process may need to be repeated for the left hand power unit once the lifting cylinder has been extended and retracted a couple of times. When satisfied that all the air has been purged from both systems, fully retract the cylinder and check the hydraulic fluid levels in each reservoir. Add fluid if necessary.

Check for free movement of the hydraulic hoses and the unfold springs. Lower the drive unit until it touches the ground. Continue until the cylinder is fully extended. Retract the lower drive unit completely making sure that the jack stands are supporting the Trailer. Check for any binding or kinking of the hoses and springs through the full travel of the cylinder. Adjust as necessary.

Install the unfold springs. Connect one end of one spring to the left anchor bracket that was mounted in step #5 and the other end of the spring bracket located just behind the hydraulic motor on the left hand track assembly. The unfold springs should have enough tension to allow the track assemblies to return to the level position just as they clear the bottom edge of the Trailer. Shorten the springs as necessary to achieve the proper tension. Be careful to leave the springs long enough to survive the full extension of the cylinder.

Check for leaks. Use the unit to lift the front of the Trailer. Temporarily remove the jack stands. Check for clearance around the Trailer and operate the unit in Forward and Reverse and steer it Left and Right. Replace the jack stands. Retract the unit far enough to gain access to the fittings on the lower drive unit.

*iDrive*