

# Service Manual

DV4500 /U1B/U1S

DVD Player

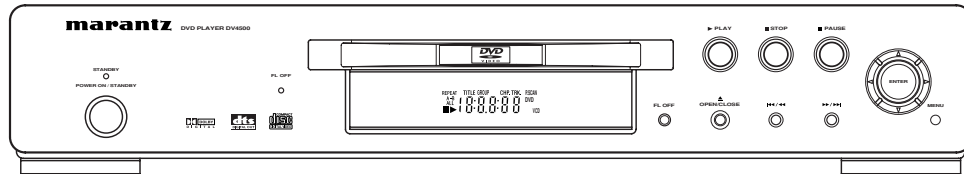

## TABLE OF CONTENTS

SECTION	PAGE
TECHNICAL SPECIFICATIONS .....	1-1-1
SERVICE HINTS AND TOOLS .....	1-2-1
WARNING AND LASER SAFETY INSTRUCTIONS .....	1-2-2
LASER BEAM SAFETY PRECAUTIONS .....	1-2-3
IMPORTANT SAFETY PRECAUTIONS .....	1-3-1
STANDARD NOTES FOR SERVICING .....	1-4-1
CABINET DISASSEMBLY INSTRUCTIONS .....	1-5-1
TROUBLESHOOTING .....	1-6-1
BLOCK DIAGRAMS .....	1-7-1
SCHEMATIC DIAGRAMS / CBA'S AND TEST POINTS .....	1-8-1
WAVEFORMS .....	1-9-1
WIRING DIAGRAMS .....	1-10-1
FIRMWARE RENEWAL MODE .....	1-11-1
IC PIN FUNCTION DESCRIPTIONS .....	1-12-1
LEAD IDENTIFICATIONS .....	1-13-1
EXPLODED VIEWS .....	1-14-1
PARTS LIST .....	1-15-1

Please use this service manual with referring to the user guide (D.F.U) without fail.  
修理の際は、必ず取扱説明書を準備し操作方法を確認の上作業を行ってください。

# marantz®

## DV4500

## MARANTZ DESIGN AND SERVICE

Using superior design and selected high grade components, **MARANTZ** company has created the ultimate in stereo sound. Only original **MARANTZ** parts can insure that your **MARANTZ** product will continue to perform to the specifications for which it is famous.

Parts for your **MARANTZ** equipment are generally available to our National Marantz Subsidiary or Agent.

### ORDERING PARTS :

Parts can be ordered either by mail or by Fax.. In both cases, the correct part number has to be specified.

The following information must be supplied to eliminate delays in processing your order :

1. Complete address
2. Complete part numbers and quantities required
3. Description of parts
4. Model number for which part is required
5. Way of shipment
6. Signature : any order form or Fax. must be signed, otherwise such part order will be considered as null and void.

#### USA

**MARANTZ AMERICA, INC**  
1100 MAPLEWOOD DRIVE  
ITASCA, IL. 60143  
USA  
PHONE : 630 - 741 - 0300  
FAX : 630 - 741 - 0301

#### EUROPE / TRADING

**MARANTZ EUROPE B.V.**  
P. O. BOX 8744, BUILDING SILVERPOINT  
BEEMDSTRAAT 11, 5653 MA EINDHOVEN  
THE NETHERLANDS  
PHONE : +31 - 40 - 2507844  
FAX : +31 - 40 - 2507860

#### CANADA

**MARANTZ CANADA INC.**  
5-505 APPLE CREEK BLVD.  
MARKHAM, ONTARIO L3R 5B1  
CANADA  
PHONE : 905 - 415 - 9292  
FAX : 905 - 475 - 4159

#### PROFESSIONAL AMERICAS

**SUPERSCOPE TECHNOLOGIES, INC.**  
MARANTZ PROFESSIONAL PRODUCTS  
2640 WHITE OAK CIRCLE, SUITE A  
AURORA, ILLINOIS 60504 USA  
PHONE : 630 - 820 - 4800  
FAX : 630 - 820 - 8103

#### PROFESSIONAL AUSTRALIA

**TECHNICAL AUDIO GROUP PTY, LTD**  
43-53 Bridge Rd.,  
STANMORE NSW 2048  
AUSTRALIA  
PHONE : +61 - (0)2 - 9519 - 0900  
FAX : +61 - (0)2 - 9519 - 0600

#### PROFESSIONAL HONG KONG

**Jolly ProAudio Broadcast Engineering Ltd.**  
UNIT 2, 10F, WAH HUNG CENTRE,  
41 HUNG TO ROAD, KWUN TONG, KLN.,  
HONG KONG  
PHONE : 852 - 21913660  
FAX : 852 - 21913990

#### AUSTRALIA

**QualiFi Pty Ltd,**  
24 LIONEL ROAD,  
MT. WAVERLEY VIC 3149  
AUSTRALIA  
PHONE : +61 - (0)3 - 9543 - 1522  
FAX : +61 - (0)3 - 9543 - 3677

#### THAILAND

**MRZ STANDARD CO., LTD**  
746 - 754 MAHACHAI ROAD.,  
WANGBURAPAPIROM, PHRANAKORN,  
BANGKOK, 10200 THAILAND  
PHONE : +66 - 2 - 222 9181  
FAX : +66 - 2 - 224 6795

#### SINGAPORE

**WO KEE HONG DISTRIBUTION PTE LTD**  
No.1 JALAN KILANG TIMOR  
#08-03 PACIFIC TECH CENTRE  
SINGAPORE 159303  
PHONE : +65 6376 0338  
FAX : +65 6376 0166

#### NEW ZEALAND

**WILDASH AUDIO SYSTEMS NZ**  
14 MALVERN ROAD MT ALBERT  
AUCKLAND NEW ZEALAND  
PHONE : +64 - 9 - 8451958  
FAX : +64 - 9 - 8463554

#### TAIWAN

**PAI- YUING CO., LTD.**  
6 TH FL NO, 148 SUNG KIANG ROAD,  
TAIPEI, 10429, TAIWAN R.O.C.  
PHONE : +886 - 2 - 25221304  
FAX : +886 - 2 - 25630415

#### MALAYSIA

**WO KEE HONG ELECTRONICS SDN. BHD.**  
2ND FLOOR BANGUNAN INFINITE CENTRE  
LOT 1, JALAN 13/6, 46200 PETALING JAYA  
SELANGOR DARUL EHSAN, MALAYSIA  
PHONE : +60 - 3 - 7954 8088  
FAX : +60 - 3 - 7954 7088

#### JAPAN *Technical*

**MARANTZ JAPAN, INC.**  
35- 1, 7- CHOME, SAGAMIONO  
SAGAMIHARA - SHI, KANAGAWA  
JAPAN 228-8505  
PHONE : +81 42 748 1013  
FAX : +81 42 741 9190

#### 日本マランツ株式会社

本社 〒228-8505  
神奈川県相模原市相模大野7-35-1

#### KOREA

**MK ENTERPRISES LTD.**  
ROOM 604/605, ELECTRO-OFFICETEL, 16-58,  
3GA, HANGANG-RO, YONGSAN-KU, SEOUL  
KOREA  
PHONE : +822 - 3232 - 155  
FAX : +822 - 3232 - 154

### SHOCK, FIRE HAZARD SERVICE TEST :

**CAUTION :** After servicing this appliance and prior to returning to customer, measure the resistance between either primary AC cord connector pins ( with unit NOT connected to AC mains and its Power switch ON ), and the face or Front Panel of product and controls and chassis bottom.

Any resistance measurement less than 1 Megohms should cause unit to be repaired or corrected before AC power is applied, and verified before it is return to the user/customer.

Ref. UL Standard No. 1492.

In case of difficulties, do not hesitate to contact the Technical Department at above mentioned address.

# TECHNICAL SPECIFICATIONS

## SIGNAL SYSTEM

---

NTSC color

## APPLICABLE DISCS

---

- (1) DVD-Video Discs  
1-layer 12cm single-sided discs, 2-layer 12cm single-sided discs, 2-layer 12cm double-sided discs (1 layer per side)  
1-layer 8cm single-sided discs, 2-layer 8cm single-sided discs, 2-layer 8cm double-sided discs (1 layer per side)
- (2) DVD-R/DVD-RW
- (3) Compact discs (CD-DA, Video CD)  
12cm discs, 8cm discs
- (4) CD-R/CD-RW

## S-VIDEO OUTPUT

---

Y output level: 1Vp-p (75  $\Omega$ )

C output level: 0.286Vp-p

Output connectors: S connectors, 1 set

## VIDEO OUTPUT

---

Output level: 1Vp-p (75  $\Omega$ )

Output connector: Pin jacks, 1 set

## COMPONENT OUTPUT

---

Y output level: 1Vp-p (75  $\Omega$ )

Cb/Pb output level: 0.7Vp-p (75  $\Omega$ )

Cr/Pr output level: 0.7Vp-p (75  $\Omega$ )

Output connector: Pin jacks, 1 set

## AUDIO OUTPUT

---

Output level: 2Vrms

2 channel (L, R) output connector: Pin jack, 1 set

## AUDIO OUTPUT PROPERTIES

---

- (1) Frequency response
  - 1 DVDs (linear PCM) : 4Hz to 22kHz (48 kHz sampling)
  - : 4Hz to 44kHz (96 kHz sampling)
  - 2 CDs : 4Hz to 20kHz
- (2) S/N ratio : 115dB
- (3) Total harmonic distortion : 1kHz CD: 0.0045%
- (4) Dynamic range : DVD: 100dB  
CD: 98dB

## DIGITAL AUDIO OUTPUT

---

Optical digital output: Optical connector, 1 set

Coaxial digital output: Pin jack, 1 set

## POWER SUPPLY

---

AC 120V, 60Hz

## POWER CONSUMPTION

---

10 W

## MAXIMUM EXTERNAL DIMENSIONS

---

W: 17-5/16" (440mm)

H: 2-61/64" (75mm)

D: 8-5/16" (211mm)

## MASS

---

4.6 lbs (2.1 kg)

## REMOTE CONTROL UNIT

---

RC6500DV

Infrared pulse type

Supply: DC 3V, 2 R6P/AA batteries

## Playable Discs

The following discs can be played back on this DVD player.

Usable discs	Mark (logo)	Recorded signals	Disc Size
DVD-Video (NOTE 1)		Digital video (MPEG2)	12 cm
DVD-R DVD-RW (NOTE 2, 3)	 		8 cm
CD CD-R CD-RW (NOTE 4)	  	Digital audio MP3 WMA (NOTE 5) Digital picture (JPEG)	12 cm 8 cm
Video CD	 	Sound and Pictures	12 cm
			8 cm (Singles)
Picture CD		JPEG	12 cm

NOTE 1: Some DVD-Video discs do not operate as described in this manual due to the intentions of the discs' producers.

NOTE 2: This unit can play DVD-RW discs recorded in DVD video format or DVD video recording format.  
\* The disc may not be played back due to recording quality or properties of the disc, dirt on the disc or the pickup lens, or condensation on the pickup lens.

NOTE 3: Discs that have not been finalized cannot be played. Depending on the disc's recording status, the disc may not be accepted or may not be played normally (the picture or sound may be not be smooth, etc.).

NOTE 4: Some of CD-R/CD-RW discs may be incompatible because of "scratch and stain of disc", "Recording condition", and "Characteristic of Recorder".

NOTE 5: Windows Media and the Windows logo are trademarks or registered trademarks of Microsoft Corporation in the United States and/or other countries.

This player conforms to the NTSC color system. You cannot play discs recorded in other color systems such as PAL.

Some discs include region codes as shown below.



The number inside the symbol refers to a region of the world, and a disc encoded in a specific region format can only be played back on DVD players with the same region code.

**RW** . This label indicates playback compatibility with DVD-RW discs recorded in VR mode (Video Recording Format).

On the following discs, only the sound can be heard (picture cannot be viewed).

CDV

CD-G

NEVER play back the following discs. Otherwise, malfunction may result!

DVD-RAM

CD-I

Photo CD

DVD with region codes other than 1 or ALL

DVD-ROM for personal computers

CD-ROM for personal computers

On the following disc, the sound MAY NOT be heard.  
Super Audio CD

## NOTE:

Only the sound recorded on the normal CD layer can be delivered.

The sound recorded on the high density Super Audio CD layer cannot be delivered.

Any other discs without compatibility indications.

## Disc Types

### [DVD-Video]

Data on a DVD is divided into sections called "titles" and then into subsections called "chapters" each of which is given a title or chapter number. Playback conditions are preset on some DVD-Video discs, and these playback conditions take priority over user operations on this player. If a function you selected does not run as desired, refer to the manual accompanying the disc.

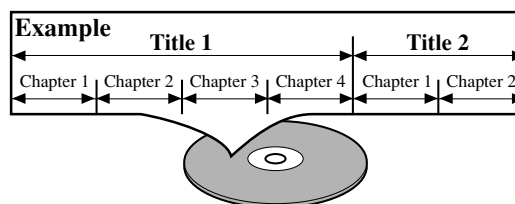

### [Audio CD, Video CD]

Data on an Audio CD, or a Video CD is divided into sections called "tracks" each of which is given a track number.

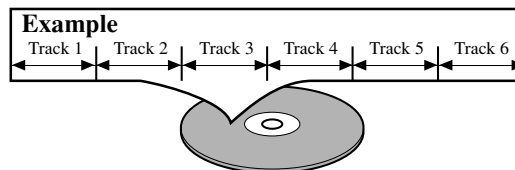

### ABOUT THE PBC FUNCTION OF VIDEO CD

This unit conforms to ver.1.1 and ver.2.0 of Video CD standard, with PBC function.

*Ver.1.1 (without PBC function):* You can enjoy playback picture as well as music CD.

*Ver.2.0 (with PBC function):* While using a Video CD with PBC function, "PBC" appears on the screen and the display.

**What is PBC?** "PBC" stands for the Playback Control. You can play interactive software using menu screens. Refer to instructions in the Video CD.

## NOTE:

When playing Video CDs with PBC function, some operations (e.g., track search and repeat tracks) cannot be performed unless the function is cancelled temporarily (Refer to page 15).

### [MP3, JPEG, WMA]

Data on an MP3, JPEG or WMA are divided into sections called "groups" and then into subsections called "tracks" each of which is given a group or track number.

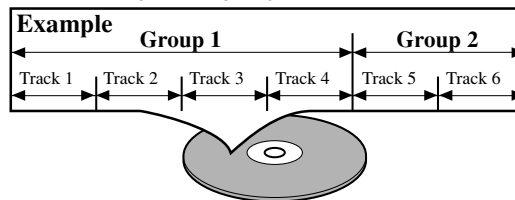

## CAUTION:

- Use caution not to pinch your finger in the disc slot.
- Be sure to remove a disc and unplug the AC power cord from the outlet before carrying the DVD player.

# SERVICE HINTS AND TOOLS

## SERVICE HINTS

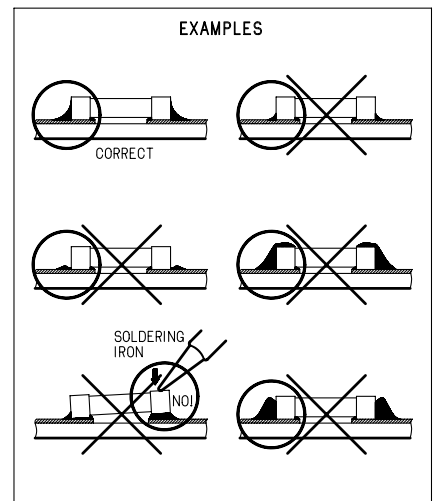
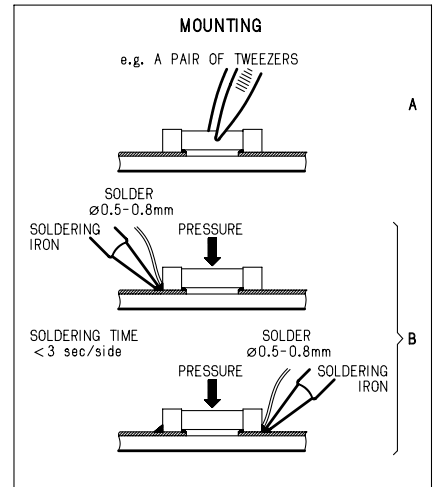
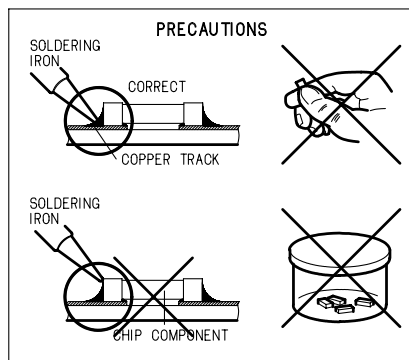
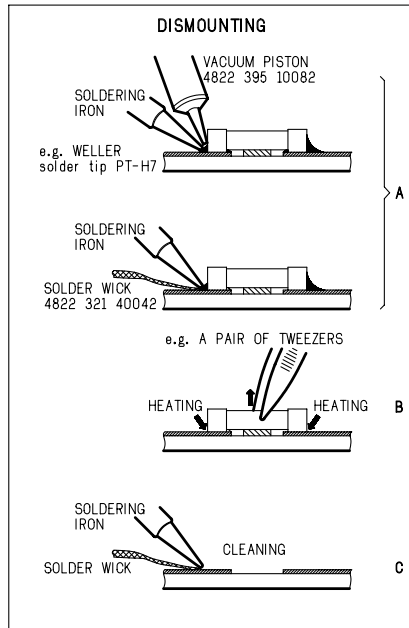
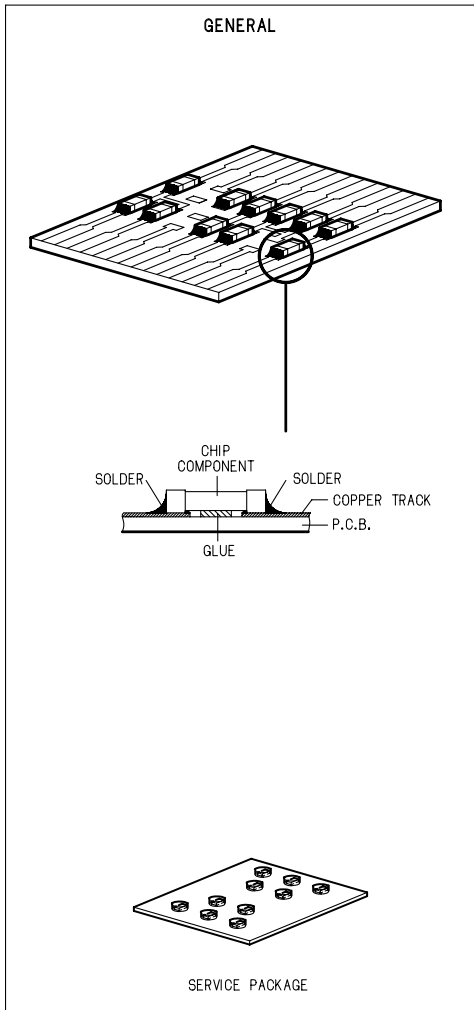

## SERVICE TOOLS

Audio signals disc	4822 397 30184
Disc without errors (SBC444)+	
Disc with DO errors, black spots and fingerprints (SBC444A)	4822 397 30245
Disc (65 min 1kHz) without no pause	4822 397 30155
Max. diameter disc (58.0 mm)	4822 397 60141
Torx screwdrivers	
Set (straight)	4822 395 50145
Set (square)	4822 395 50132
13th order filter	4822 395 30204
DVD test disc (PAL)	4822 397 10131
DVD test disc (NTSC) ALMEDIO	TDV-540

# WARNING AND LASER SAFETY INSTRUCTIONS

## **(GB)** WARNING

All ICs and many other semi-conductors are susceptible to electrostatic discharges (ESD). Careless handling during repair can reduce life drastically.  
When repairing, make sure that you are connected with the same potential as the mass of the set via a wrist wrap with resistance.  
Keep components and tools also at this potential.



## **(NL)** WAARSCHUWING

Alle IC's en vele andere halfgeleiders zijn gevoelig voor elektrostatische ontladingen (ESD).  
Onzorgvuldig behandelen tijdens reparatie kan de levensduur drastisch doen verminderen.  
Zorg ervoor dat u tijdens reparatie via een polsband met weerstand verbonden bent met hetzelfde potentiaal als de massa van het apparaat.  
Houd componenten en hulpmiddelen ook op ditzelfde potentiaal.

## **(F)** ATTENTION

Tous les IC et beaucoup d'autres semi-conducteurs sont sensibles aux décharges statiques (ESD).  
Leur longévité pourrait être considérablement écourtée par le fait qu'aucune précaution n'est prise à leur manipulation.  
Lors de réparations, s'assurer de bien être relié au même potentiel que la masse de l'appareil et enfiler le bracelet serti d'une résistance de sécurité.  
Veiller à ce que les composants ainsi que les outils que l'on utilise soient également à ce potentiel.

## **(D)** WARNUNG

Alle IC und viele andere Halbleiter sind empfindlich gegen elektrostatische Entladungen (ESD).  
Unvorsichtige Behandlung bei der Reparatur kann die Lebensdauer drastisch vermindern.  
Sorgen sie dafür, das Sie im Reparaturfall über ein Pulsarmband mit Widerstand mit dem Massepotential des Gerätes verbunden sind.  
Halten Sie Bauteile und Hilfsmittel ebenfalls auf diesem Potential.

## **(I)** AVVERTIMENTO

Tutti IC e parecchi semi-conduttori sono sensibili alle scariche statiche (ESD).  
La loro longevità potrebbe essere fortemente ridotta in caso di non osservazione della più grande cauzione alla loro manipolazione.  
Durante le riparazioni occorre quindi essere collegato allo stesso potenziale che quello della massa dell'apparecchio tramite un braccialetto a resistenza.  
Assicurarsi che i componenti e anche gli utensili con quali si lavora siano anche a questo potenziale.

## **(GB)**

Safety regulations require that the set be restored to its original condition and that parts which are identical with those specified be used.

## **(NL)**

Veiligheidsbepalingen vereisen, dat het apparaat in zijn oorspronkelijke toestand wordt terug gebracht en dat onderdelen, identiek aan de gespecificeerde worden toegepast.

"Pour votre sécurité, ces documents doivent être utilisés par des spécialistes agréés, seuls habilités à réparer votre appareil en panne."

## **(F)**

Les normes de sécurité exigent que l'appareil soit remis à l'état d'origine et que soient utilisées les pièces de rechange identiques à celles spécifiées.

## **(D)**

Bei jeder Reparatur sind die geltenden Sicherheitsvorschriften zu beachten.  
Der Originalzustand des Gerats darf nicht verändert werden.  
Für Reparaturen sind Original-Ersatzteile zu verwenden.

## **(I)**

Le norme di sicurezza esigono che l'apparecchio venga rimesso nelle condizioni originali e che siano utilizzati pezzi di ricambio identici a quelli specificati.

## LASER SAFETY

This unit employs a laser. Only a qualified service person should remove the cover or attempt to service this device, due to possible eye injury.



**USE OF CONTROLS OR ADJUSTMENTS OR PERFORMANCE OF PROCEDURE OTHER THAN THOSE SPECIFIED HEREIN MAY RESULT IN HAZARDOUS RADIATION EXPOSURE.**

**AVOID DIRECT EXPOSURE TO BEAM**

## WARNING

**The use of optical instruments with this product will increase eye hazard.  
Repair handling should take place as much as possible with a disc loaded inside the player**

## WARNING LOCATION: INSIDE ON LASER COVERSIELD

**CAUTION** VISIBLE AND INVISIBLE LASER RADIATION WHEN OPEN AVOID EXPOSURE TO BEAM  
**ADVARSEL** SYNLIG OG USYNLIG LASERSTRÅLING VED ÅBNING UNDGÅ UDSÆTTELSE FOR STRÅLING  
**ADVARSEL** SYNLIG OG USYNLIG LASERSTRÅLING NÅR DEKSEL Å PNES UNNGÅ EKSPONERING FOR STRÅLEN  
**WARNING** SYNLIG OCH OSYNLIG LASERSTRÅLNING NÅR DENNA DEL ÅR ÖPPNAD BETRakta EJ STRÅLEN  
**VARO!** AVATT AESSA OLET ALTTIINA NÄKYVÄLLE JA NÄKYMÄTTÖMÄLLE LASER SÄTEILYLLE. ÄLÄ KATSO SÄTEESEEN  
**VORSICHT** SICHTBARE UND UNSICHTBARE LASERSTRAHLUNG WENN ABDECKUNG GEÖFFNET NICHT DEM STRAHL AUSSETZEN  
**DANGER** VISIBLE AND INVISIBLE LASER RADIATION WHEN OPEN AVOID DIRECT EXPOSURE TO BEAM  
**ATTENTION** RAYONNEMENT LASER VISIBLE ET INVISIBLE EN CAS D'OUVERTURE EXPOSITION DANGEREUSE AU FAISCEAU

# LASER BEAM SAFETY PRECAUTIONS

This DVD player uses a pickup that emits a laser beam.

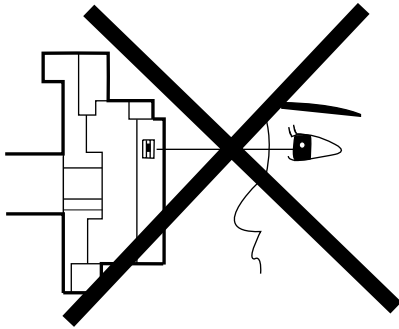

Do not look directly at the laser beam coming from the pickup or allow it to strike against your skin.

The laser beam is emitted from the location shown in the figure. When checking the laser diode, be sure to keep your eyes at least 30cm away from the pickup lens when the diode is turned on. Do not look directly at the laser beam.

**Caution:** Use of controls and adjustments, or doing procedures other than those specified herein, may result in hazardous radiation exposure.

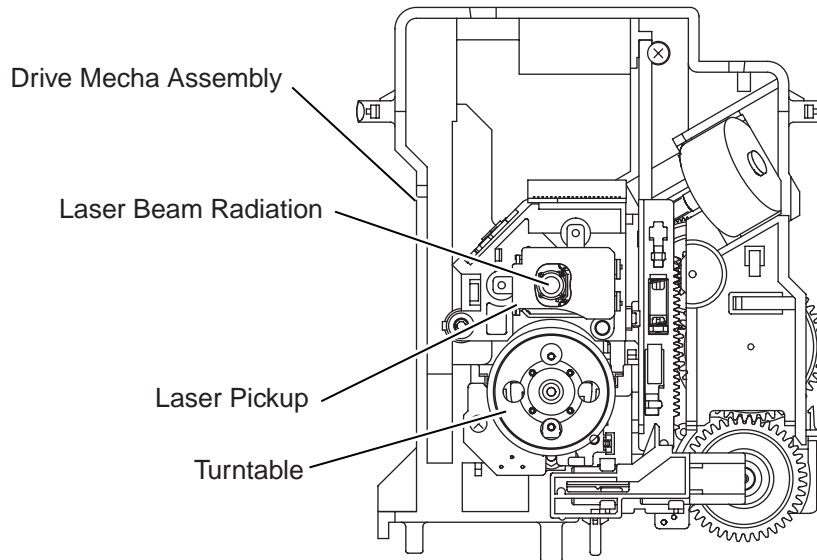

**CAUTION**  
LASER RADIATION  
WHEN OPEN. DO NOT  
STARE INTO BEAM.

**Location: Top of DVD mechanism.**

# IMPORTANT SAFETY PRECAUTIONS

## Product Safety Notice

Some electrical and mechanical parts have special safety-related characteristics which are often not evident from visual inspection, nor can the protection they give necessarily be obtained by replacing them with components rated for higher voltage, wattage, etc. Parts that have special safety characteristics are identified by a **▲** on schematics and in parts lists. Use of a substitute replacement that does not have the same safety characteristics as the recommended replacement part might create shock, fire, and/or other hazards. The Product's Safety is under review continuously and new instructions are issued whenever appropriate. Prior to shipment from the factory, our products are carefully inspected to confirm with the recognized product safety and electrical codes of the countries in which they are to be sold. However, in order to maintain such compliance, it is equally important to implement the following precautions when a set is being serviced.

## Precautions during Servicing

- A.** Parts identified by the **▲** symbol are critical for safety. Replace only with part number specified.
- B.** In addition to safety, other parts and assemblies are specified for conformance with regulations applying to spurious radiation. These must also be replaced only with specified replacements.  
Examples: RF converters, RF cables, noise blocking capacitors, and noise blocking filters, etc.
- C.** Use specified internal wiring. Note especially:
  - 1) Wires covered with PVC tubing
  - 2) Double insulated wires
  - 3) High voltage leads
- D.** Use specified insulating materials for hazardous live parts. Note especially:
  - 1) Insulation tape
  - 2) PVC tubing
  - 3) Spacers
  - 4) Insulators for transistors
- E.** When replacing AC primary side components (transformers, power cord, etc.), wrap ends of wires securely about the terminals before soldering.
- F.** Observe that the wires do not contact heat producing parts (heatsinks, oxide metal film resistors, fusible resistors, etc.).
- G.** Check that replaced wires do not contact sharp edges or pointed parts.
- H.** When a power cord has been replaced, check that 5 - 6 kg of force in any direction will not loosen it.

- I.** Also check areas surrounding repaired locations.
- J.** Be careful that foreign objects (screws, solder droplets, etc.) do not remain inside the set.
- K.** Crimp type wire connector  
The power transformer uses crimp type connectors which connect the power cord and the primary side of the transformer. When replacing the transformer, follow these steps carefully and precisely to prevent shock hazards.  
Replacement procedure
  - 1) Remove the old connector by cutting the wires at a point close to the connector.  
**Important:** Do not re-use a connector. (Discard it.)
  - 2) Strip about 15 mm of the insulation from the ends of the wires. If the wires are stranded, twist the strands to avoid frayed conductors.
  - 3) Align the lengths of the wires to be connected. Insert the wires fully into the connector.
  - 4) Use a crimping tool to crimp the metal sleeve at its center. Be sure to crimp fully to the complete closure of the tool.
- L.** When connecting or disconnecting the internal connectors, first, disconnect the AC plug from the AC outlet.



## Safety Check after Servicing

Examine the area surrounding the repaired location for damage or deterioration. Observe that screws, parts, and wires have been returned to their original positions. Afterwards, do the following tests and confirm the specified values to verify compliance with safety standards.

### 1. Clearance Distance

When replacing primary circuit components, confirm specified clearance distance ( $d$ ) and ( $d'$ ) between soldered terminals, and between terminals and surrounding metallic parts. (See Fig. 1)

**Table 1: Ratings for selected area**

AC Line Voltage	Clearance Distance ( $d$ ), ( $d'$ )
120 V	$\geq 3.2\text{mm}$ (0.126 inches)

**Note:** This table is unofficial and for reference only. Be sure to confirm the precise values.

### 2. Leakage Current Test

Confirm the specified (or lower) leakage current between B (earth ground, power cord plug prongs) and externally exposed accessible parts (RF terminals, antenna terminals, video and audio input and output terminals, microphone jacks, earphone jacks, etc.) is lower than or equal to the specified value in the table below.

#### Measuring Method (Power ON) :

Insert load  $Z$  between B (earth ground, power cord plug prongs) and exposed accessible parts. Use an AC voltmeter to measure across the terminals of load  $Z$ . See Fig. 2 and the following table.

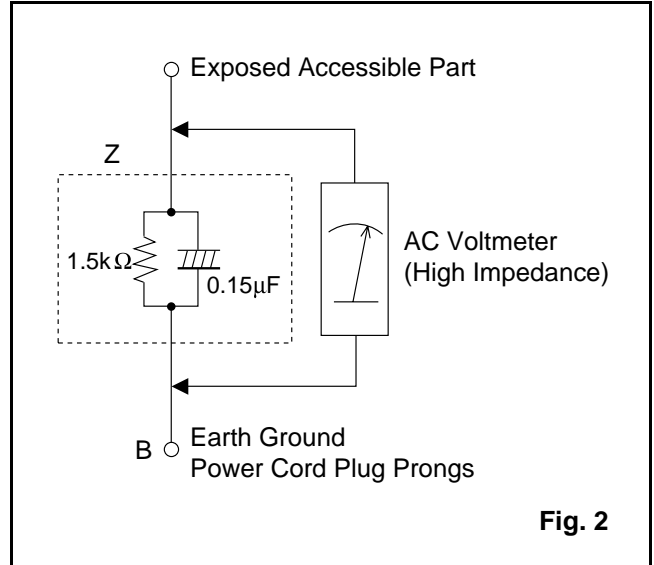
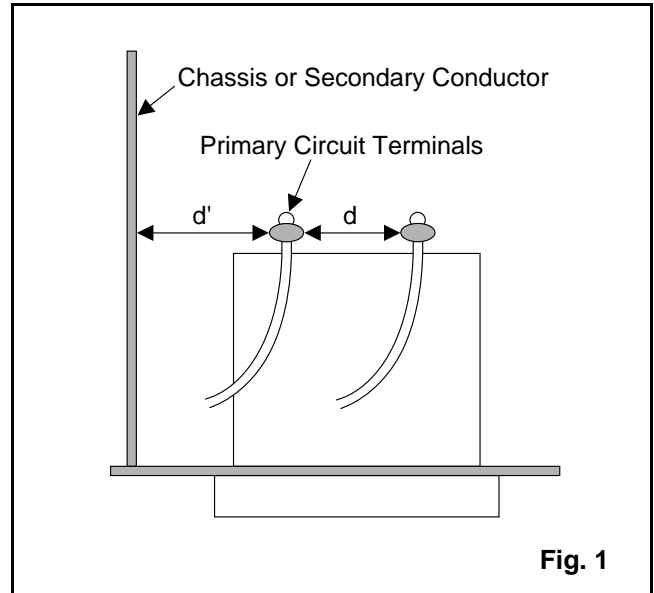

**Table 2: Leakage current ratings for selected areas**

AC Line Voltage	Load Z	Leakage Current ( $i$ )	Earth Ground (B) to:
120 V	$0.15\mu\text{F}$ CAP. & $1.5\text{k}\Omega$ RES. Connected in parallel	$i \leq 0.5\text{mA}$ Peak	Exposed accessible parts

**Note:** This table is unofficial and for reference only. Be sure to confirm the precise values.

# STANDARD NOTES FOR SERVICING

## Circuit Board Indications

1. The output pin of the 3 pin Regulator ICs is indicated as shown.

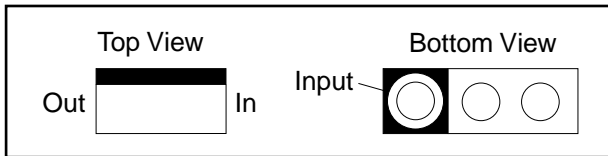

2. For other ICs, pin 1 and every fifth pin are indicated as shown.

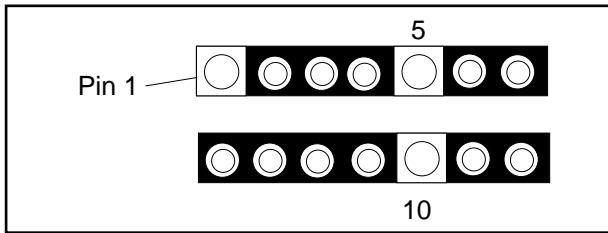

3. The 1st pin of every male connector is indicated as shown.

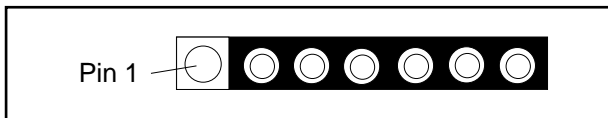

## Instructions for Connectors

1. When you connect or disconnect the FFC (Flexible Foil Connector) cable, be sure to first disconnect the AC cord.
2. FFC (Flexible Foil Connector) cable should be inserted parallel into the connector, not at an angle.

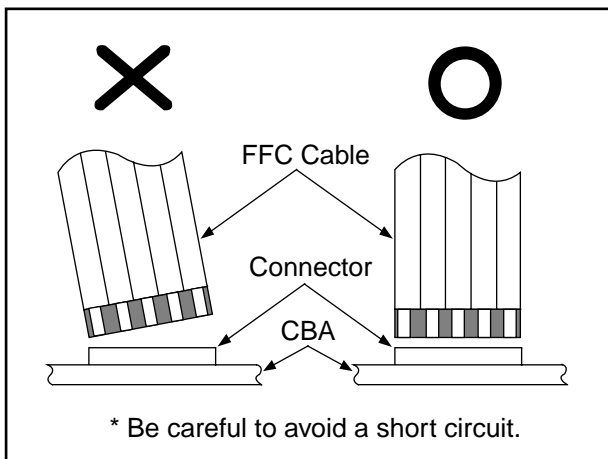

## Pb (Lead) Free Solder

When soldering, be sure to use the Pb free solder.

## How to Remove / Install Flat Pack-IC

### 1. Removal

With Hot-Air Flat Pack-IC Desoldering Machine:

- (1) Prepare the hot-air flat pack-IC desoldering machine, then apply hot air to the Flat Pack-IC (about 5 to 6 seconds). (Fig. S-1-1)

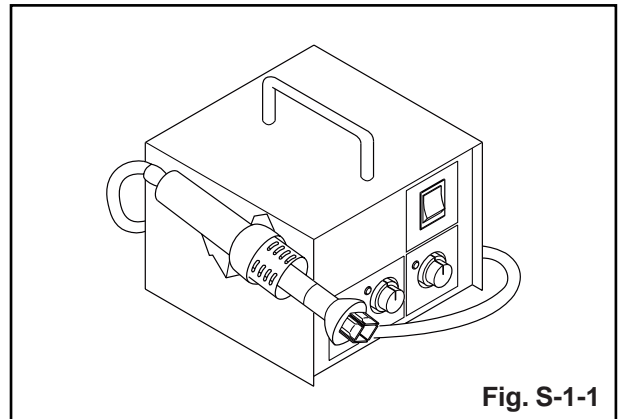

- (2) Remove the flat pack-IC with tweezers while applying the hot air.
- (3) Bottom of the flat pack-IC is fixed with glue to the CBA; when removing entire flat pack-IC, first apply soldering iron to center of the flat pack-IC and heat up. Then remove (glue will be melted). (Fig. S-1-6)
- (4) Release the flat pack-IC from the CBA using tweezers. (Fig. S-1-6)

### Caution:

1. The Flat Pack-IC shape may differ by models. Use an appropriate hot-air flat pack-IC desoldering machine, whose shape matches that of the Flat Pack-IC.
2. Do not supply hot air to the chip parts around the flat pack-IC for over 6 seconds because damage to the chip parts may occur. Put masking tape around the flat pack-IC to protect other parts from damage. (Fig. S-1-2)

3. The flat pack-IC on the CBA is affixed with glue, so be careful not to break or damage the foil of each pin or the solder lands under the IC when removing it.

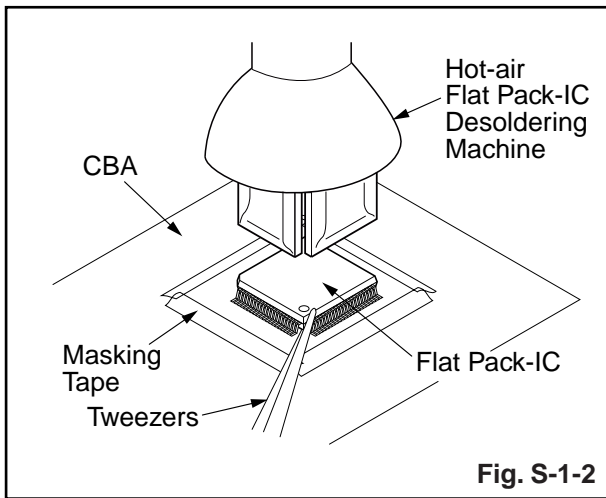

#### With Soldering Iron:

- (1) Using desoldering braid, remove the solder from all pins of the flat pack-IC. When you use solder flux which is applied to all pins of the flat pack-IC, you can remove it easily. (Fig. S-1-3)

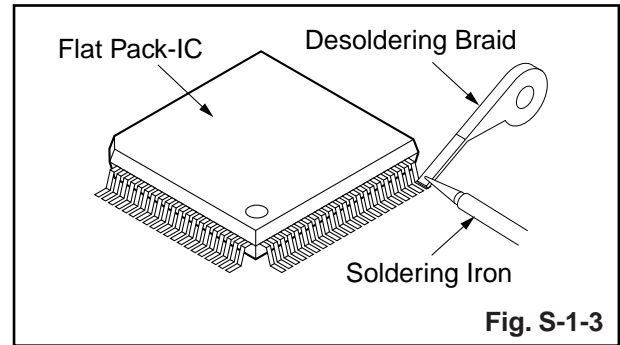

- (2) Lift each lead of the flat pack-IC upward one by one, using a sharp pin or wire to which solder will not adhere (iron wire). When heating the pins, use a fine tip soldering iron or a hot air desoldering machine. (Fig. S-1-4)

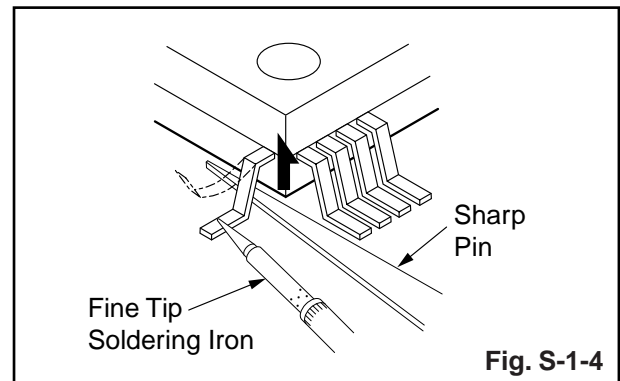

- (3) Bottom of the flat pack-IC is fixed with glue to the CBA; when removing entire flat pack-IC, first apply soldering iron to center of the flat pack-IC and heat up. Then remove (glue will be melted). (Fig. S-1-6)
- (4) Release the flat pack-IC from the CBA using tweezers. (Fig. S-1-6)

### With Iron Wire:

- (1) Using desoldering braid, remove the solder from all pins of the flat pack-IC. When you use solder flux which is applied to all pins of the flat pack-IC, you can remove it easily. (Fig. S-1-3)
- (2) Affix the wire to a workbench or solid mounting point, as shown in Fig. S-1-5.
- (3) While heating the pins using a fine tip soldering iron or hot air blower, pull up the wire as the solder melts so as to lift the IC leads from the CBA contact pads as shown in Fig. S-1-5.
- (4) Bottom of the flat pack-IC is fixed with glue to the CBA; when removing entire flat pack-IC, first apply soldering iron to center of the flat pack-IC and heat up. Then remove (glue will be melted). (Fig. S-1-6)
- (5) Release the flat pack-IC from the CBA using tweezers. (Fig. S-1-6)

### Note:

When using a soldering iron, care must be taken to ensure that the flat pack-IC is not being held by glue. When the flat pack-IC is removed from the CBA, handle it gently because it may be damaged if force is applied.

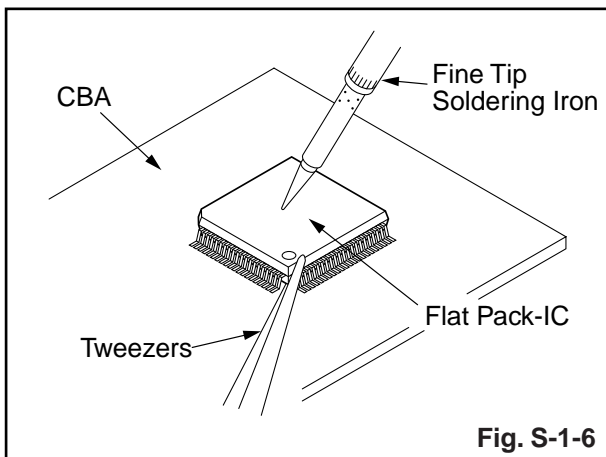
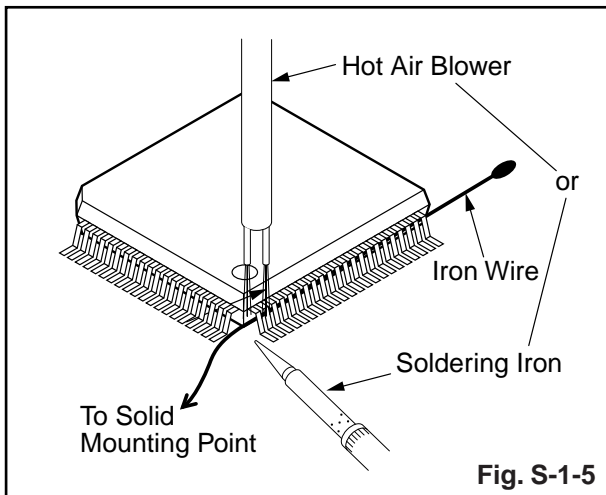

## 2. Installation

- (1) Using desoldering braid, remove the solder from the foil of each pin of the flat pack-IC on the CBA so you can install a replacement flat pack-IC more easily.
- (2) The "●" mark on the flat pack-IC indicates pin 1. (See Fig. S-1-7.) Be sure this mark matches the 1 on the PCB when positioning for installation. Then presolder the four corners of the flat pack-IC. (See Fig. S-1-8.)
- (3) Solder all pins of the flat pack-IC. Be sure that none of the pins have solder bridges.

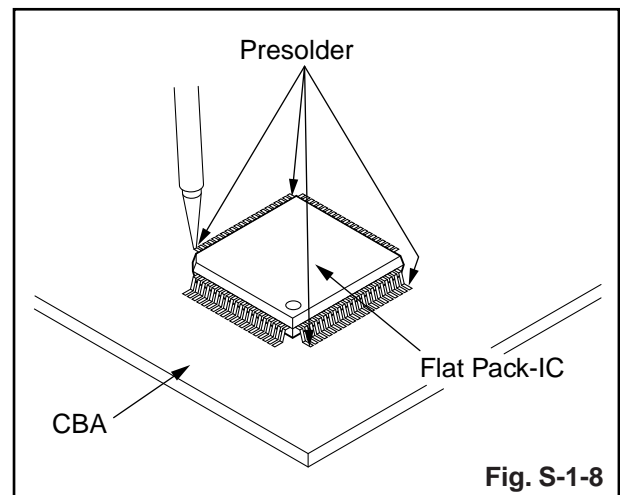
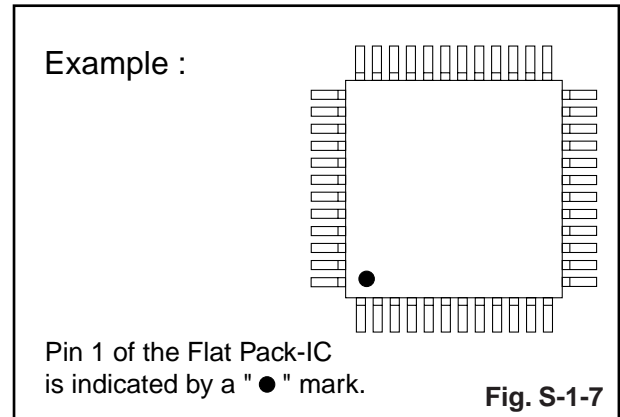

# Instructions for Handling Semi-conductors

Electrostatic breakdown of the semi-conductors may occur due to a potential difference caused by electrostatic charge during unpacking or repair work.

## 1. Ground for Human Body

Be sure to wear a grounding band ( $1M\Omega$ ) that is properly grounded to remove any static electricity that may be charged on the body.

## 2. Ground for Workbench

(1) Be sure to place a conductive sheet or copper plate with proper grounding ( $1M\Omega$ ) on the workbench or other surface, where the semi-conductors are to be placed. Because the static electricity charge on clothing will not escape through the body grounding band, be careful to avoid contacting semi-conductors with your clothing.

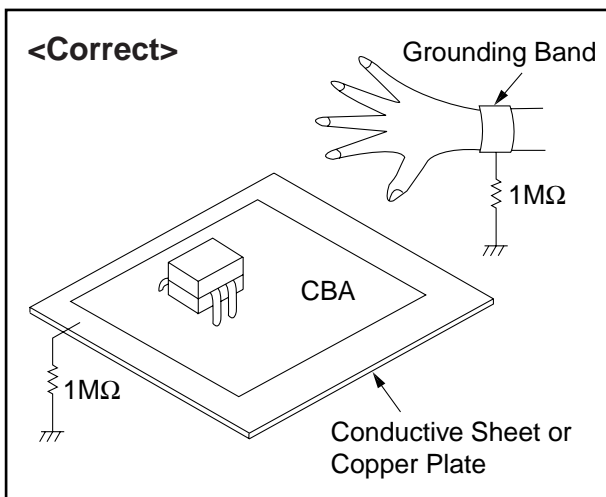
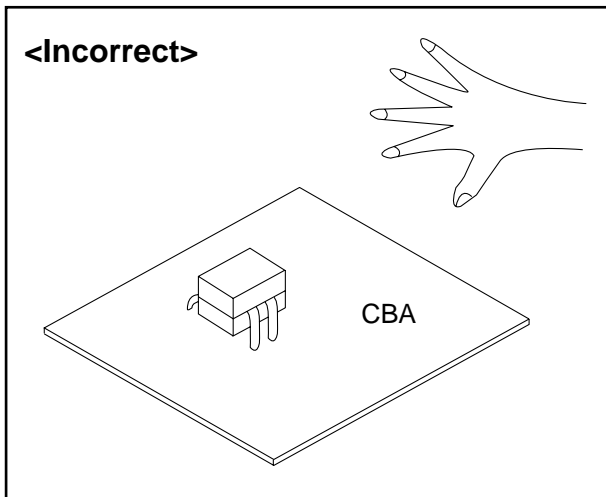

# CABINET DISASSEMBLY INSTRUCTIONS

## 1. Disassembly Flowchart

This flowchart indicates the disassembly steps to gain access to item(s) to be serviced. When reassembling, follow the steps in reverse order. Bend, route, and dress the cables as they were originally.

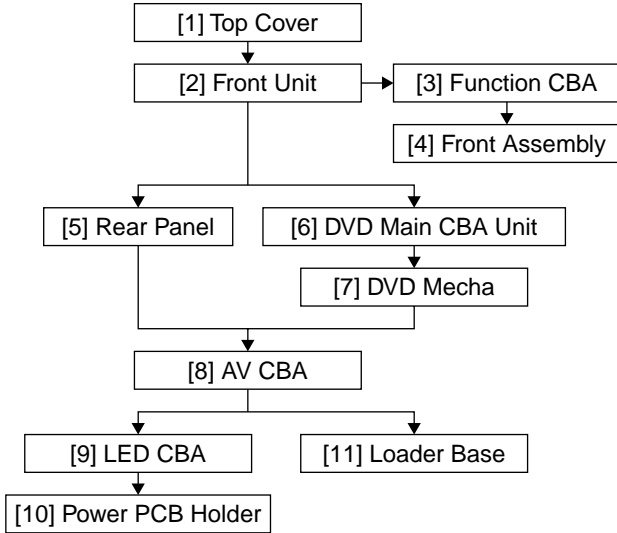

## 2. Disassembly Method

ID/ LOC. No.	PART	REMOVAL		
		Fig. No.	REMOVE/*UNHOOK/ UNLOCK/RELEASE/ UNPLUG/DESOLDER	Note
[1]	Top Cover	D1	5(S-1)	-
[2]	Front Unit	D2	*2(L-1), Tray Panel, *2(L-2), *3(L-3), *CN2081	1 1-1 1-2 1-3 1-4 1-5 1-6 1-7
[3]	Function CBA	D3	6(S-2)	-
[4]	Front Assembly	D3	-----	-
[5]	Rear Panel	D4	6(S-3), 3(S-4)	-
[6]	DVD Main CBA Unit	D5	(S-5A), (S-5B), *CN201, *CN301, *CN401, *CN601	2 2-1 2-2
[7]	DVD Mecha	D5 D6	4(S-6)	2 3
[8]	AV CBA	D7	3(S-7), (S-8), *CN2082	-
[9]	LED CBA	D7	2(S-9)	-

ID/ LOC. No.	PART	REMOVAL		
		Fig. No.	REMOVE/*UNHOOK/ UNLOCK/RELEASE/ UNPLUG/DESOLDER	Note
[10]	Power PCB Holder	D7	-----	-
[11]	Loader Base	D8	4(S-10)	-

↓                      ↓                      ↓                      ↓                      ↓  
 (1)                      (2)                      (3)                      (4)                      (5)

- (1): Identification (location) No. of parts in the figures  
 (2): Name of the part  
 (3): Figure Number for reference  
 (4): Identification of parts to be removed, unhooked, unlocked, released, unplugged, unclamped, or desoldered.  
 P=Spring, L=Locking Tab, S=Screw,  
 CN=Connector  
 \*=Unhook, Unlock, Release, Unplug, or Desolder  
 e.g. 2(S-2) = two Screws (S-2),  
 2(L-2) = two Locking Tabs (L-2)  
 (5): Refer to "Reference Notes."

### About tightening screws

When tightening screws, tighten them with the following torque.

Screws	Torque
(S-1), (S-2), (S-3), (S-4), (S-5A), (S-6), (S-7), (S-8), (S-9), (S-10)	0.45 ± 0.05 N·m
(S-5B)	0.38 ± 0.04 N·m

### Reference Notes

CAUTION 1: Locking Tabs (L-1), (L-2) and (L-3) are fragile. Be careful not to break them.

- 1-1. Connect the wall plug to an AC outlet and press the [OPEN/CLOSE] button to open the tray.
- 1-2. Remove the Tray Panel by releasing two locking tabs (L-1).
- 1-3. Press the [OPEN/CLOSE] button again to close the tray.
- 1-4. Press the [POWER] button to turn the power off.
- 1-5. Unplug an AC cord.
- 1-6. Disconnect connector CN2081.
- 1-7. Release two Locking Tabs (L-2). Then release three Locking Tabs (L-3), and remove the Front Unit.

**CAUTION 2:** Electrostatic breakdown of the laser diode in the optical system block may occur as a potential difference caused by electrostatic charge accumulated on cloth, human body etc, during unpacking or repair work.

To avoid damage of pickup follow next procedures.

2-1. Short the three short lands of FPC cable with solder before removing the FFC cable (CN201) from it. If you disconnect the FFC cable (CN201), the laser diode of pickup will be destroyed. (Fig. D4)

2-2. Disconnect Connectors (CN301), (CN401) and (CN601). Remove two Screws (S-5A) and (S-5B) and lift the DVD Main CBA Unit. (Fig. D4)

**CAUTION 3:** When reassembling, confirm the FFC cable (CN201) is connected completely. Then remove the solder from the three short lands of FPC cable. (Fig. D4)

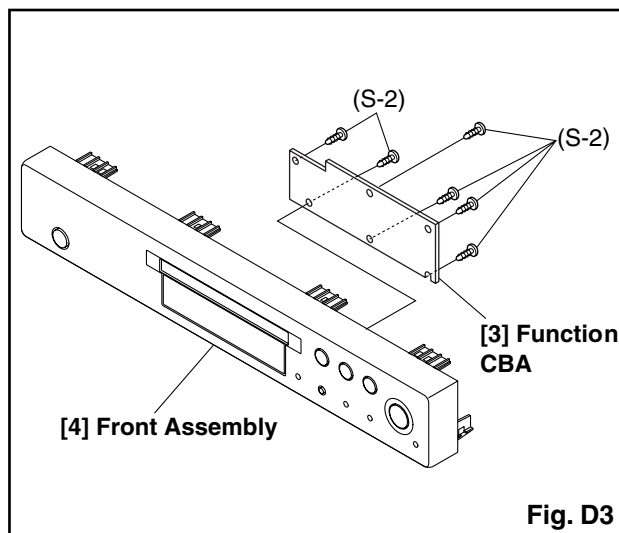

**Fig. D3**

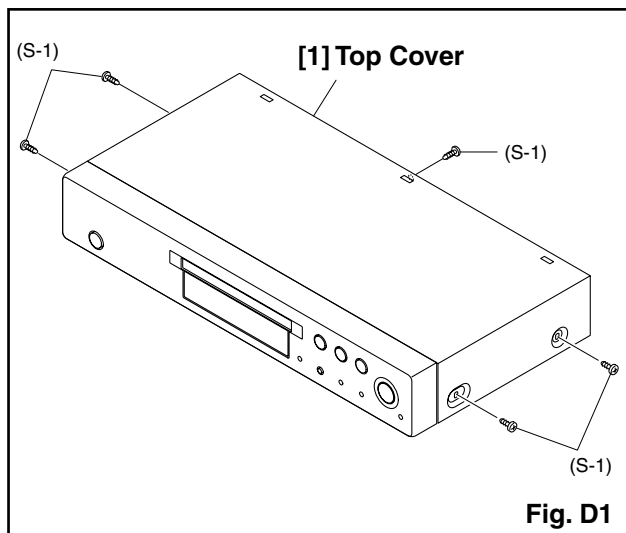

**Fig. D1**

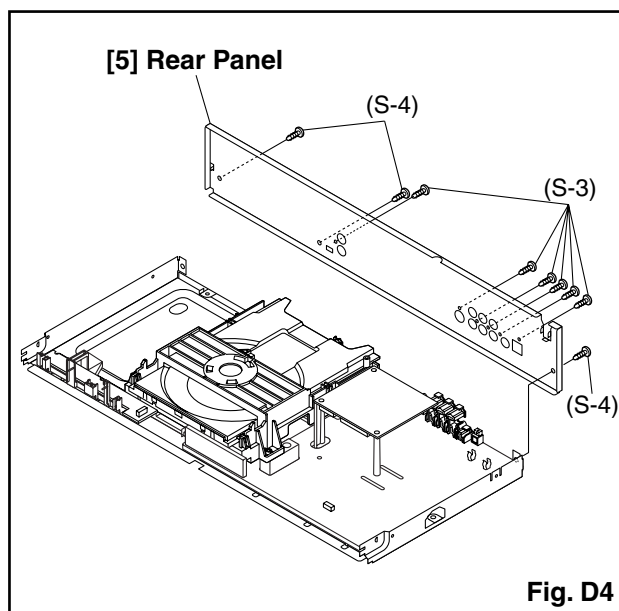

**Fig. D4**

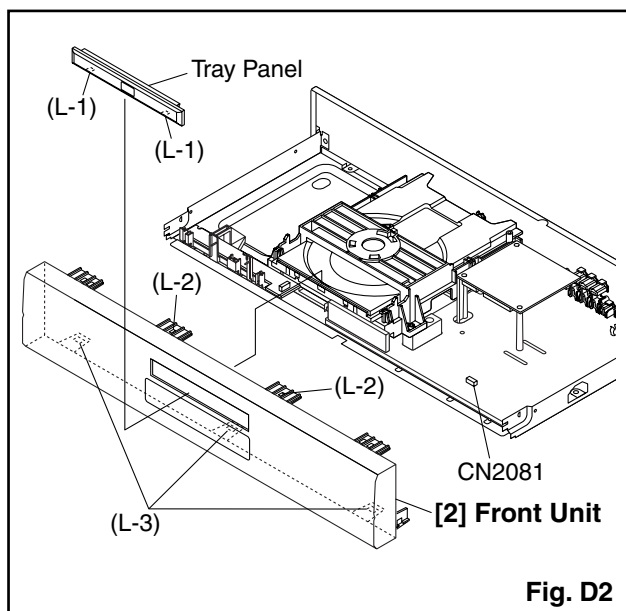

**Fig. D2**

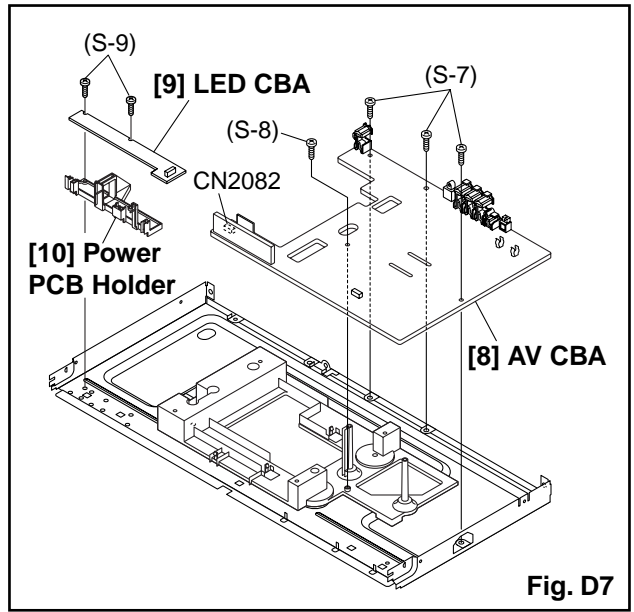
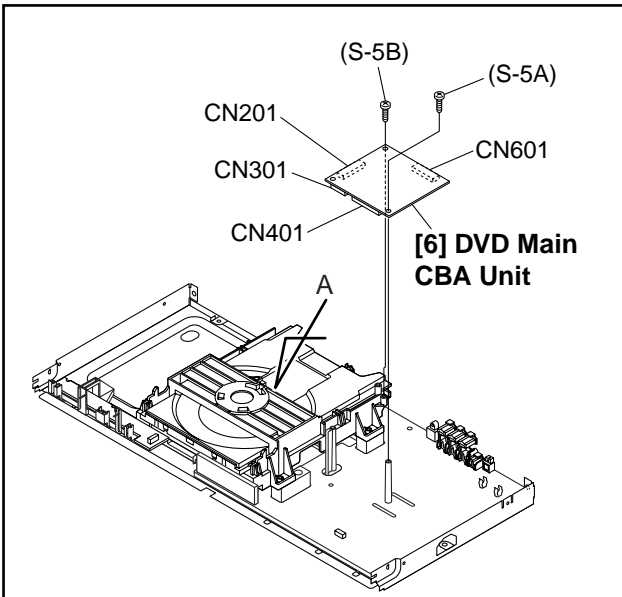

Fig. D7

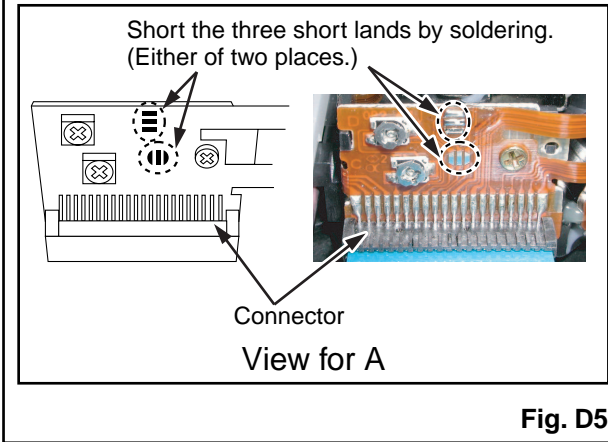

Fig. D5

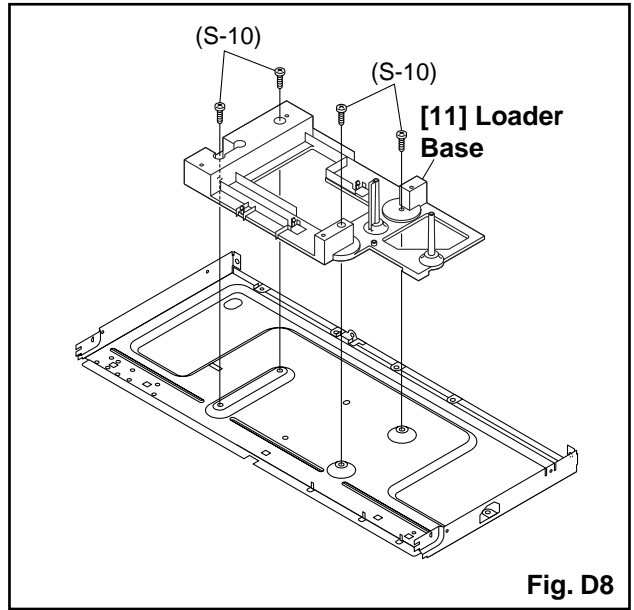

Fig. D8

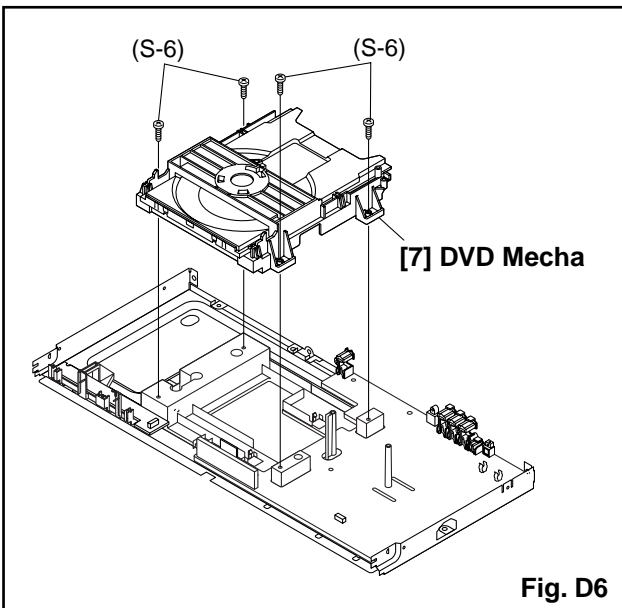
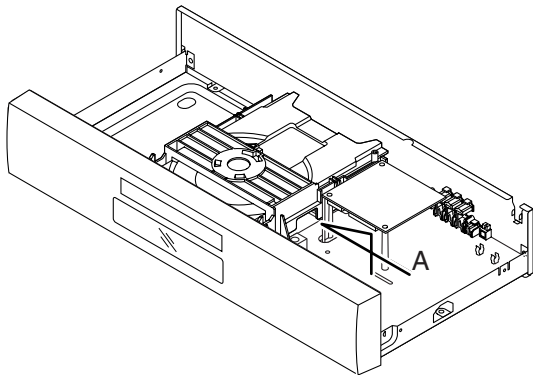

Fig. D6



## HOW TO EJECT MANUALLY

1. Remove the Top Cover.
2. Rotate the roulette in the direction of the arrow as shown below.



View for A

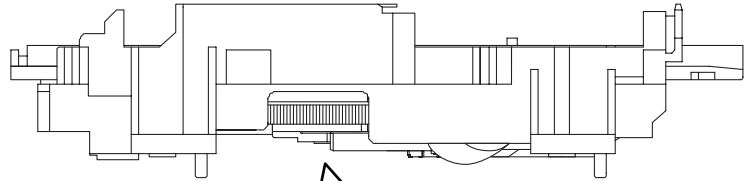

Rotate this roulette in  
the direction of the arrow

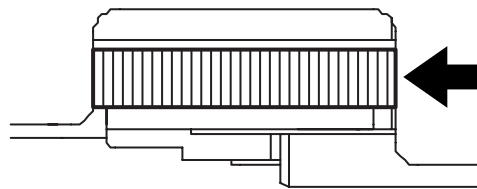

# TROUBLESHOOTING

## FLOW CHART NO.1

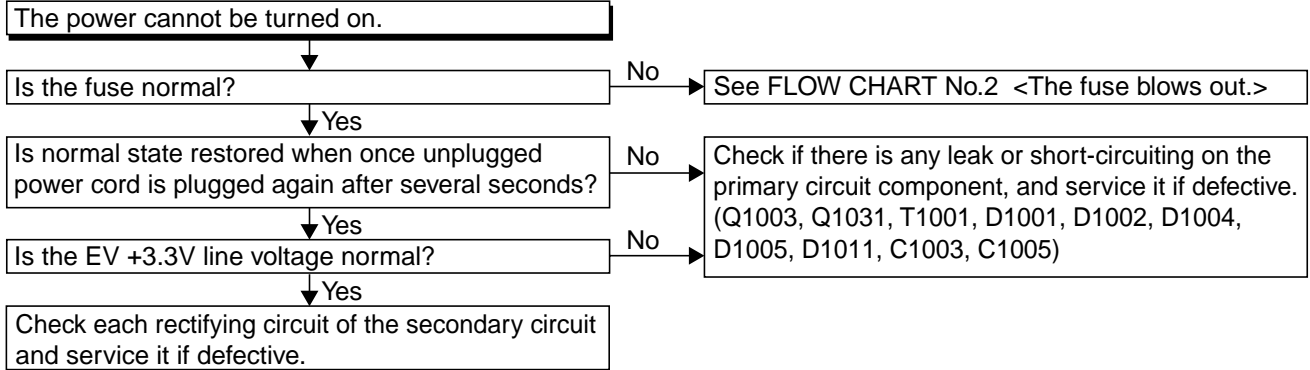

## FLOW CHART NO.2

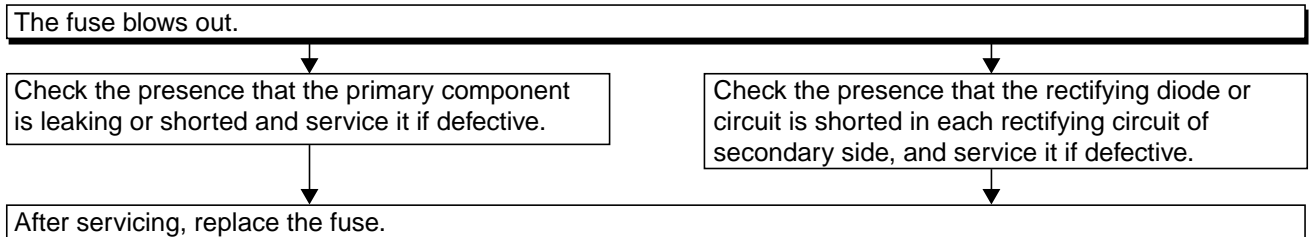

## FLOW CHART NO.3

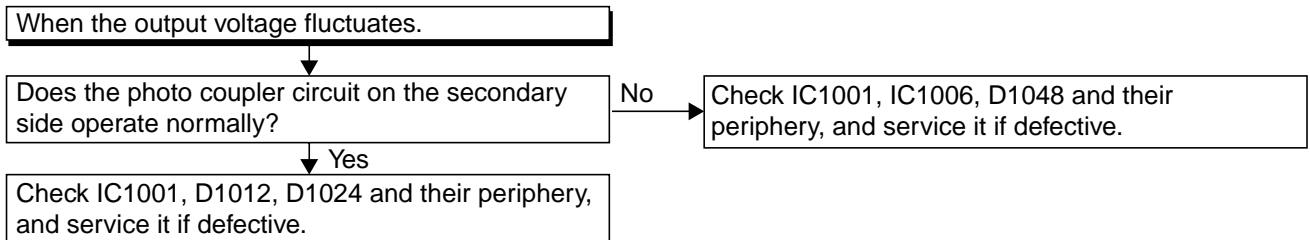

## FLOW CHART NO.4

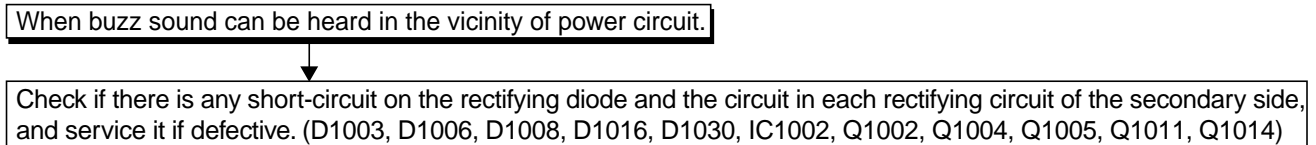

## FLOW CHART NO.5

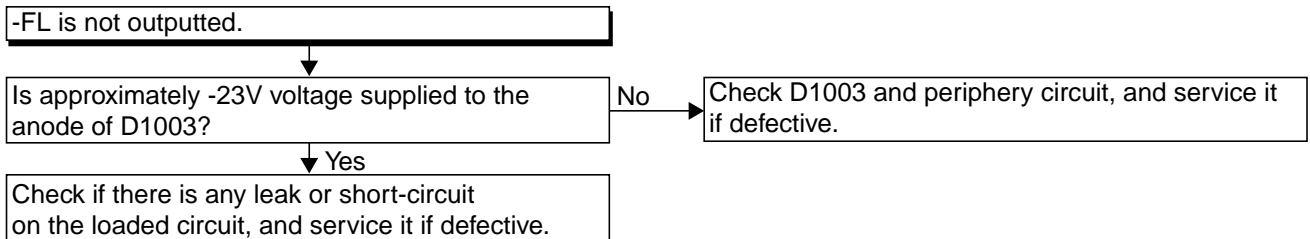

### FLOW CHART NO.6

P-ON+11V (EV+11V) is not outputted.

Is 11V voltage supplied to the emitter of Q1002?

No

Check D1030, D1048, C1035, C1048, L1009 and the periphery circuit, and service it if defective.

Yes

Is the voltage of base on Q1002 lower than the voltage of emitter on Q1002 when turning the power on?

No

Check Q1016 and PWRCON line and service it if defective.

Yes

Replace Q1002.

### FLOW CHART NO.7

P-ON+5V is not outputted. (EV+11V is outputted normally.)

Is the "H" signal inputted into the base of Q1004?

No

Check R1068 and D1046, and service it if defective.

Yes

Replace Q1004.

### FLOW CHART NO.8

P-ON+3.3V is not outputted. (P-ON+11V is outputted normally.)

Is 3.3V voltage supplied to the collector of Q1011?

No

Check D1008, C1007, C1038, L1007 and the periphery circuit, and service it if defective.

Yes

Replace Q1011 or R1067.

### FLOW CHART NO.9

EV+5V is not outputted.

Is EV+11V outputted normally?

No

Refer to "FLOW CHART NO.6"  
<P-ON+11V (EV+11V) is not outputted.>

Yes

Is the "H" signal inputted into the base of Q1014?

No

Check D1047, R1069, R1098 and the periphery circuit, and service it if defective.

Yes

Replace Q1014.

### FLOW CHART NO.10

EV+1.2V is not outputted.

Is 2.5V voltage supplied to Pin(1) of IC1002?

No

Check D1006, C1014, C1050, L1008 and the periphery circuit, and service it if defective.

Yes

Replace IC1002.

### FLOW CHART NO.11

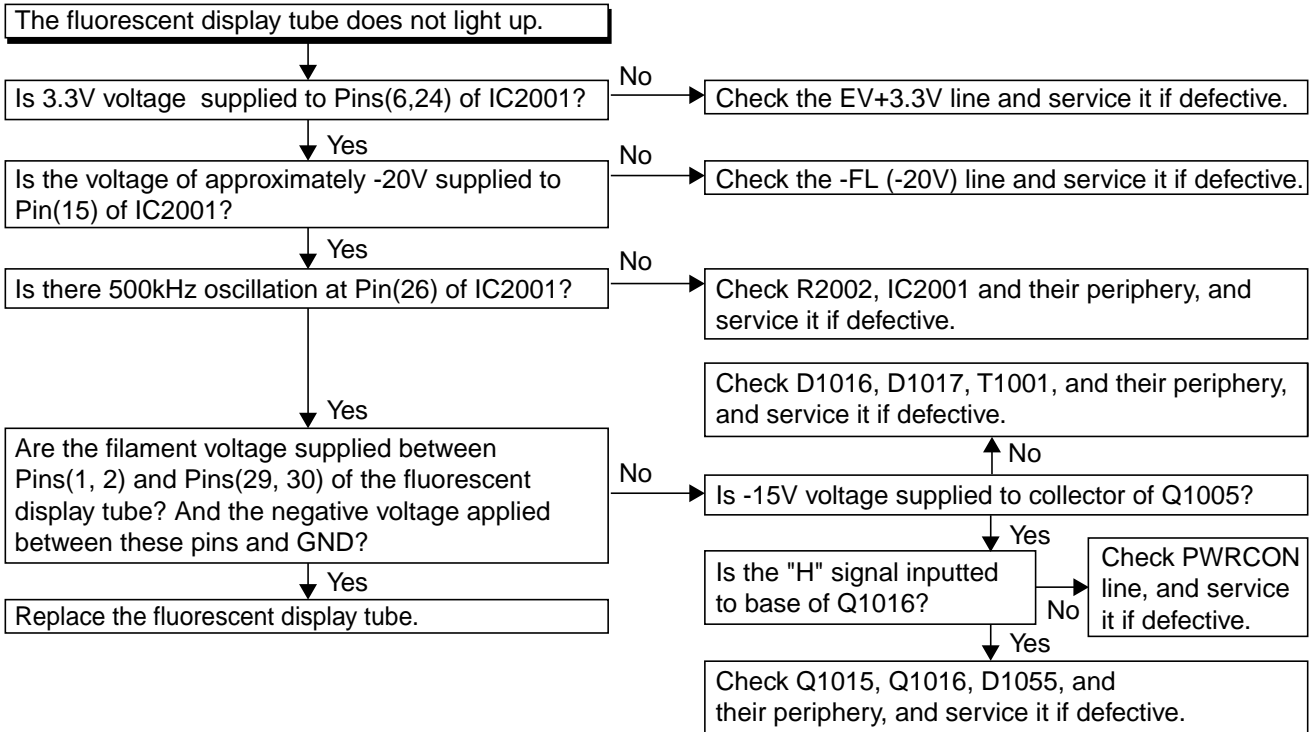

### FLOW CHART NO.12

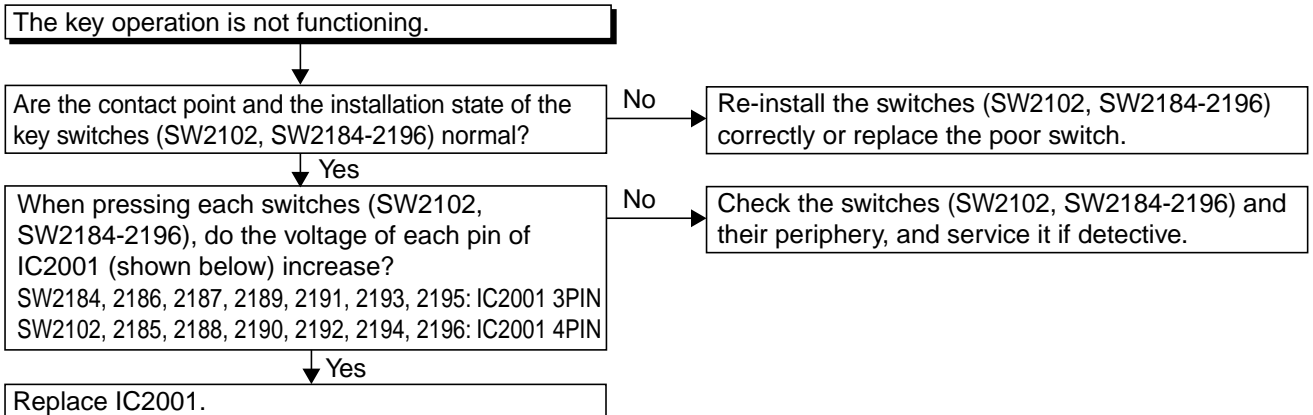

### FLOW CHART NO.13

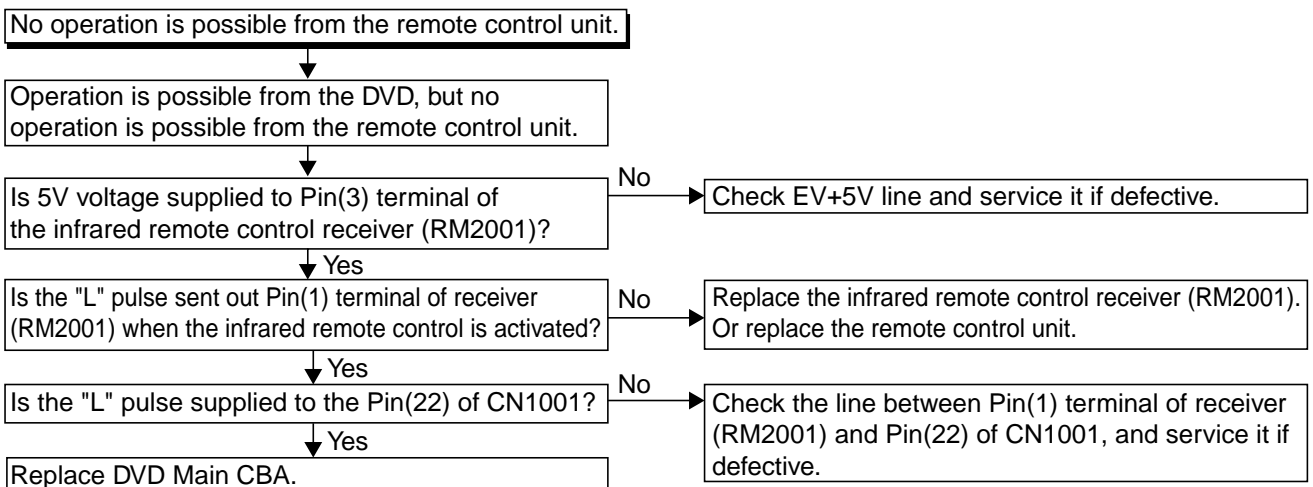

**FLOW CHART NO.14**

The disc tray cannot be opened and closed. (It can be done using the remote control unit.)

Is the normal control voltage inputted to Pin(4) of IC2001? Refer to "FLOW CHART NO.12" <The key operation is not functioning.>

No → Replace the "OPEN/CLOSE" button (SW2188).

Yes  
Refer to "FLOW CHART NO.15" <The disc tray cannot be opened and closed.>

**FLOW CHART NO.15**

The disc tray cannot be opened and closed.

Replace the DVD Main CBA.

No improvement can be found.

No → Original DVD Main CBA is poor.

Yes  
Replace the DVD Mecha.

**FLOW CHART NO.16**

[No Disc] indicated. (When the focus error occurs.)

Replace the DVD Main CBA.

No improvement can be found.

No → Original DVD Main CBA is poor.

Yes  
Replace the DVD Mecha.

**FLOW CHART NO.17**

[No Disc] indicated. (When the focus servo is not functioning.)

Replace the DVD Main CBA.

No improvement can be found.

No → Original DVD Main CBA is poor.

Yes  
Replace the DVD Mecha.

**FLOW CHART NO.18**

[No Disc] indicated. (When the laser beam does not light up.)

Replace the DVD Main CBA.

No improvement can be found.

No → Original DVD Main CBA is poor.

Yes  
Replace the DVD Mecha.

**FLOW CHART NO.19**

Both functions of picture and sound do not operate normally.

Replace the DVD Main CBA.

No improvement can be found.

No → Original DVD Main CBA is poor.

Yes

Replace the DVD Mecha.

**FLOW CHART NO.20**

Picture does not appear normally.

Set the disc on the disc tray, and playback.

Are the video signals outputted to each pin of CN1601 on the AV CBA?

No → Replace the DVD Main CBA or DVD Mecha.

CN1601	3PIN	S-Y
CN1601	4PIN	Cr/Pr
CN1601	6PIN	Cb/Pb
CN1601	8PIN	Y
CN1601	10PIN	S-C

Yes

Are the video signals shown above inputted into each pin of IC1402, IC1403?

No → Check the line between each pin of CN1601 and each pin of IC1402, IC1403 on the AV CBA, and service it if defective.

IC1402	3PIN	Y
IC1402	6PIN	Cb/Pb
IC1402	8PIN	Cr/Pr
IC1403	3PIN	S-Y
IC1403	1PIN	S-C

CN1601	8PIN → IC1402	3PIN	Y
CN1601	6PIN → IC1402	6PIN	Cb/Pb
CN1601	4PIN → IC1402	8PIN	Cr/Pr
CN1601	3PIN → IC1403	3PIN	S-Y
CN1601	10PIN → IC1403	1PIN	S-C

Yes

Are the video signals outputted to each pin of IC1402, IC1403?

No → Is 5V voltage applied to the pin(4, 12) of IC1402, pin(4) of IC1403?

IC1402	13PIN	Y
IC1402	11PIN	Cb/Pb
IC1402	10PIN	Cr/Pr
IC1403	6PIN	CVBS
IC1403	5PIN	S-Y
IC1403	7PIN	S-C

Yes → Replace IC1402, IC1403.

No → Check P-ON+5V line and service it if defective.

Yes

Are the video signals outputted to the specific output terminal?

Are the luminance signals outputted to the S-VIDEO OUT terminal (JK1401)?

No → Check the periphery of JK1401 from Pin (5) of IC1403 and service it if defective.

Are the chroma signals outputted to the S-VIDEO OUT terminal (JK1401)?

No → Check the periphery of JK1401 from Pin (7) of IC1403 and service it if defective.

Are the Y, Cb/Pb, Cr/Pr signals outputted to the COMPONENT OUT terminal (JK1404)?

No → Check the periphery of JK1404 from Pins (10, 11, 13) of IC1402 and service it if defective.

Are the composite video signals outputted to the VIDEO OUT terminal (JK1404)?

No → Check the periphery of JK1404 from Pin(6) of IC1403 and service it if defective.

**FLOW CHART NO.21**

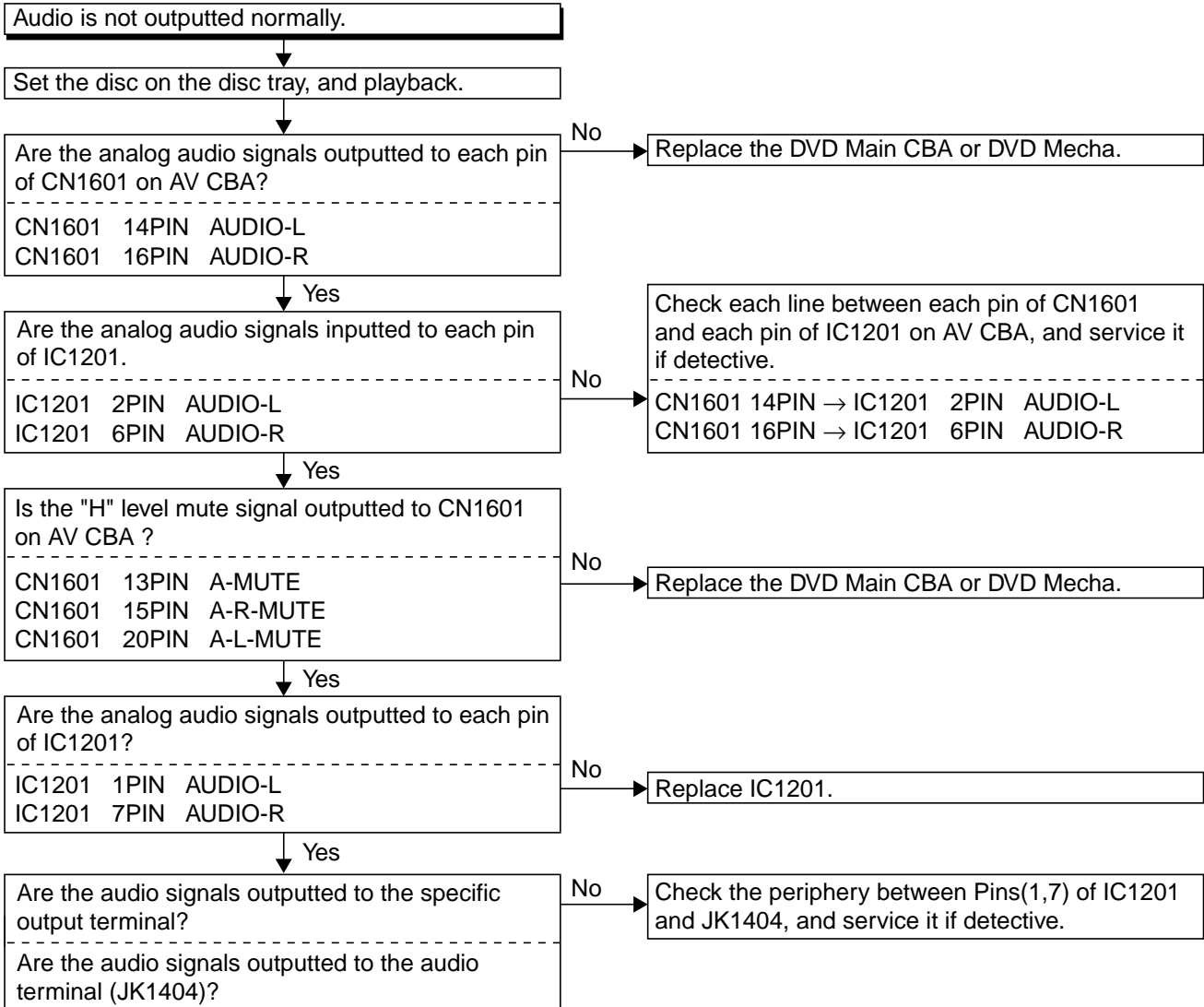

# BLOCK DIAGRAMS

## System Control / Servo Block Diagram

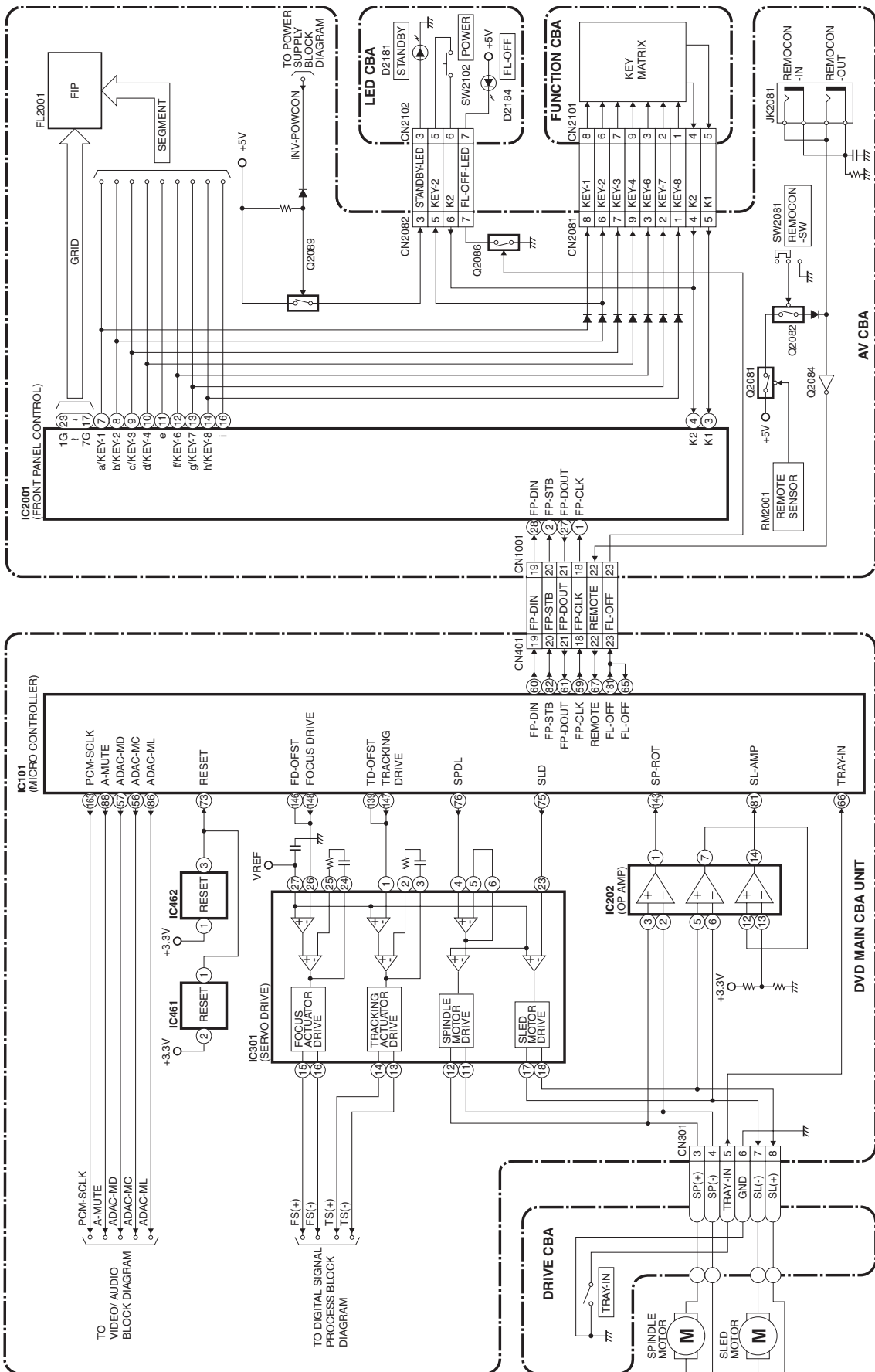



# Digital Signal Process Block Diagram

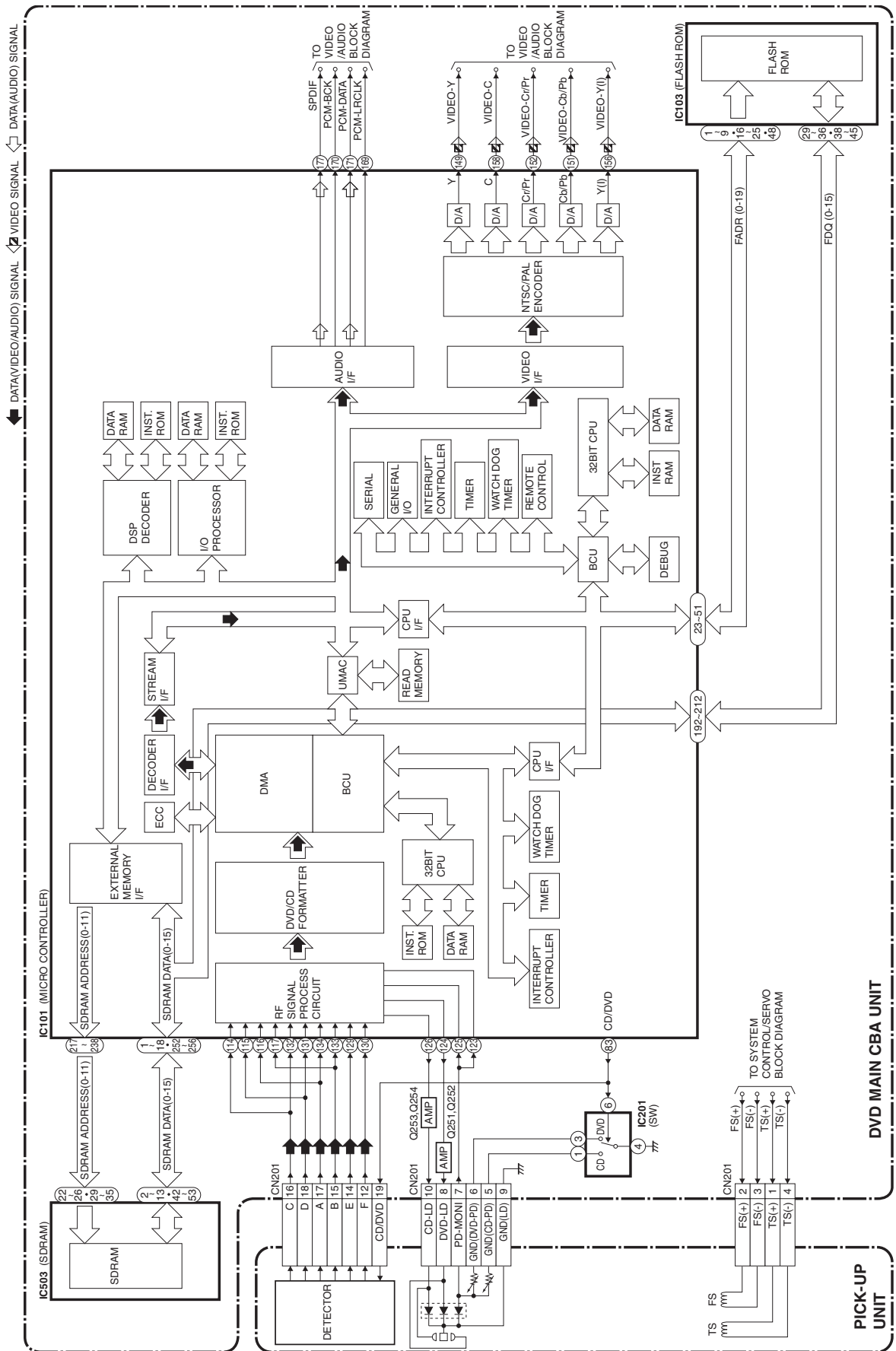

# Video / Audio Block Diagram

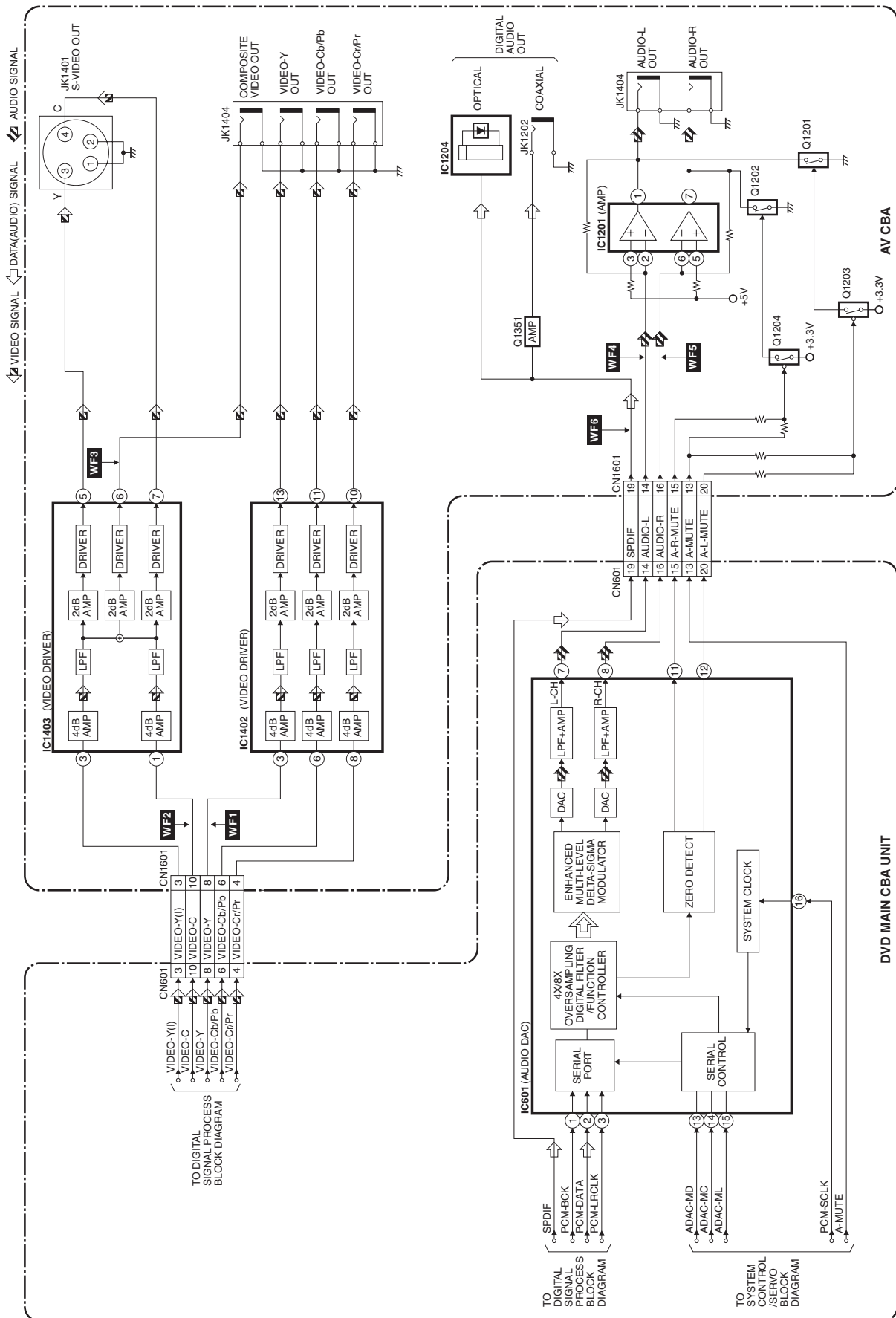

# Power Supply Block Diagram

**CAUTION !**  
Fixed voltage ( or Auto voltage selectable ) power supply circuit is used in this unit.  
If Main Fuse (F1001) is blown, check to see that all components in the power supply circuit are not defective before you connect the AC plug to the AC power supply.  
Otherwise it may cause some components in the power supply circuit to fail.

**CAUTION**  
FOR CONTINUED PROTECTION AGAINST FIRE HAZARD,  
REPLACE ONLY WITH THE SAME TYPE FUSE.  
ATTENTION : POUR UNE PROTECTION CONTINUE LES RISQUES  
D'INCENDIE UTILISER QUE DES FUSIBLES DE MÊME TYPE.  
**RISK OF FIRE -REPLACE FUSE AS MARKED.**  
This symbol means fast operating fuse.  
Ce symbole représente un fusible à fusion rapide.

**NOTE :**  
The voltage for parts in hot circuit is measured using hot GND as a common terminal.

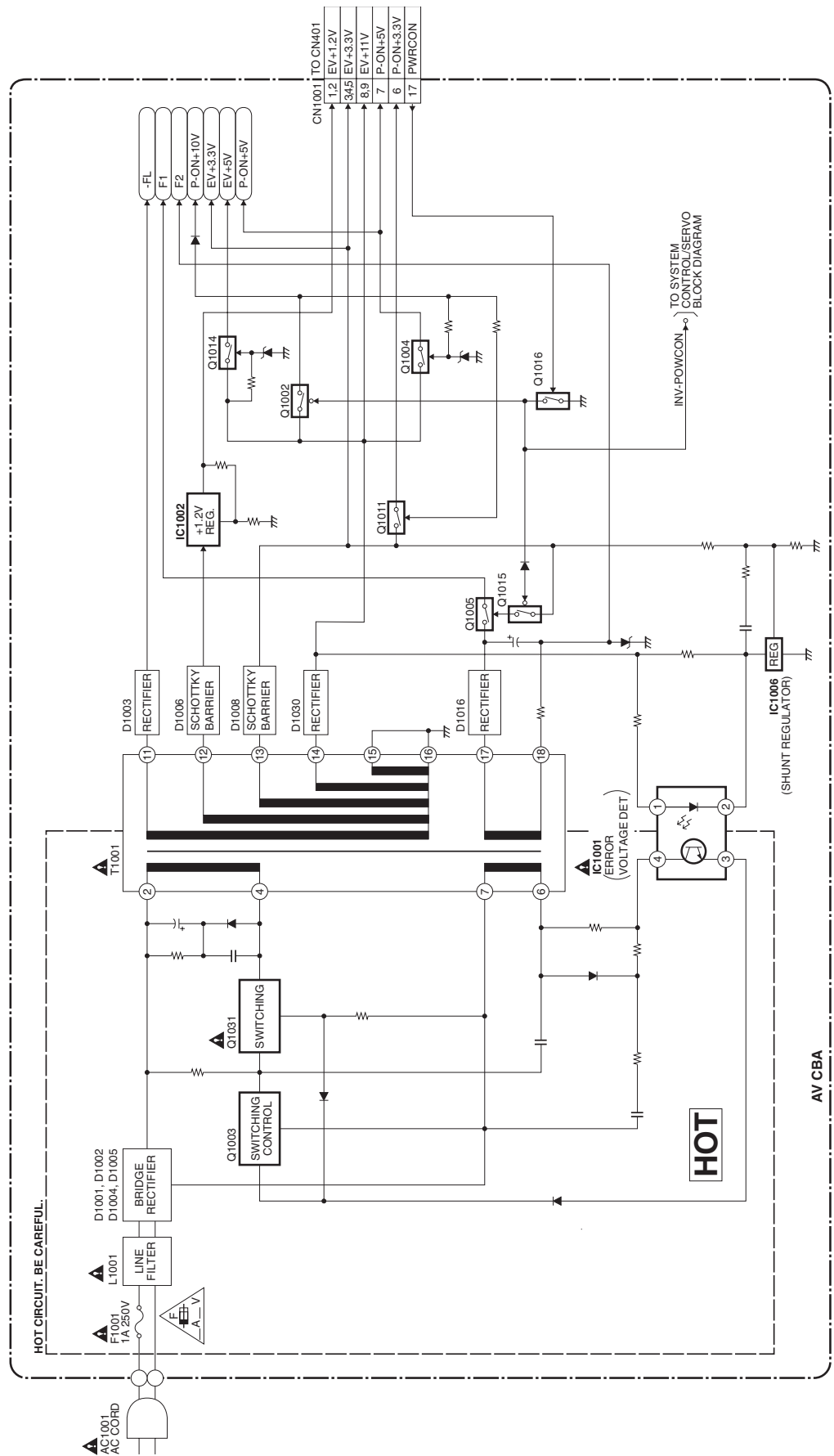

# SCHEMATIC DIAGRAMS / CBA'S AND TEST POINTS

## Standard Notes

### WARNING

Many electrical and mechanical parts in this chassis have special characteristics. These characteristics often pass unnoticed and the protection afforded by them cannot necessarily be obtained by using replacement components rated for higher voltage, wattage, etc. Replacement parts that have these special safety characteristics are identified in this manual and its supplements; electrical components having such features are identified by the mark "▲" in the schematic diagram and the parts list. Before replacing any of these components, read the parts list in this manual carefully. The use of substitute replacement parts that do not have the same safety characteristics as specified in the parts list may create shock, fire, or other hazards.

### Notes:

1. Do not use the part number shown on these drawings for ordering. The correct part number is shown in the parts list, and may be slightly different or amended since these drawings were prepared.
2. All resistance values are indicated in ohms (K=10<sup>3</sup>, M=10<sup>6</sup>).
3. Resistor wattages are 1/4W or 1/6W unless otherwise specified.
4. All capacitance values are indicated in μF (P=10<sup>-6</sup> μF).
5. All voltages are DC voltages unless otherwise specified.

**LIST OF CAUTION, NOTES, AND SYMBOLS USED IN THE SCHEMATIC DIAGRAMS ON THE FOLLOWING PAGES:**

**1. CAUTION:**

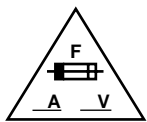

FOR CONTINUED PROTECTION AGAINST FIRE HAZARD, REPLACE ONLY WITH THE SAME TYPE FUSE.  
 ATTENTION: POUR UNE PROTECTION CONTINUE LES RISQUES D'INCELE N'UTILISER QUE DES FUSIBLE DE MÊME TYPE.  
 RISK OF FIRE-REPLACE FUSE AS MARKED.



This symbol means fast operating fuse.  
 Ce symbole représente un fusible à fusion rapide.

**2. CAUTION:**

Fixed Voltage (or Auto voltage selectable) power supply circuit is used in this unit.  
 If Main Fuse (F1001) is blown, first check to see that all components in the power supply circuit are not defective before you connect the AC plug to the AC power supply. Otherwise it may cause some components in the power supply circuit to fail.

**3. Note:**

- (1) Do not use the part number shown on the drawings for ordering. The correct part number is shown in the parts list, and may be slightly different or amended since the drawings were prepared.
- (2) To maintain original function and reliability of repaired units, use only original replacement parts which are listed with their part numbers in the parts list section of the service manual.

**4. Voltage indications for PLAY and STOP mode on the schematics are as shown below:**

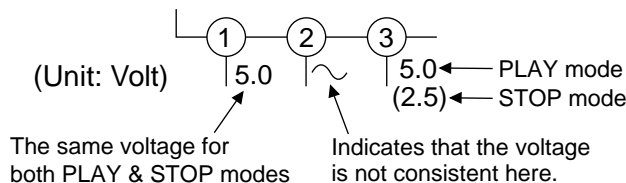

**5. How to read converged lines**

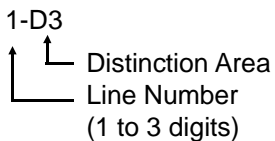

Examples:

1. "1-D3" means that line number "1" goes to area "D3".
2. "1-B1" means that line number "1" goes to area "B1".

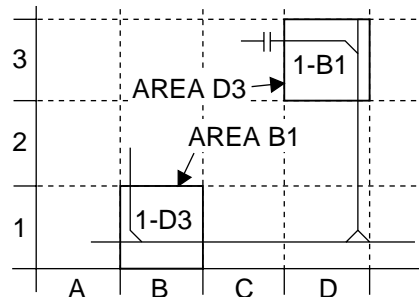

**6. Test Point Information**

- : Indicates a test point with a jumper wire across a hole in the PCB.
- : Used to indicate a test point with a component lead on foil side.
- : Used to indicate a test point with no test pin.
- : Used to indicate a test point with a test pin.

# DVD Main 1/3 Schematic Diagram

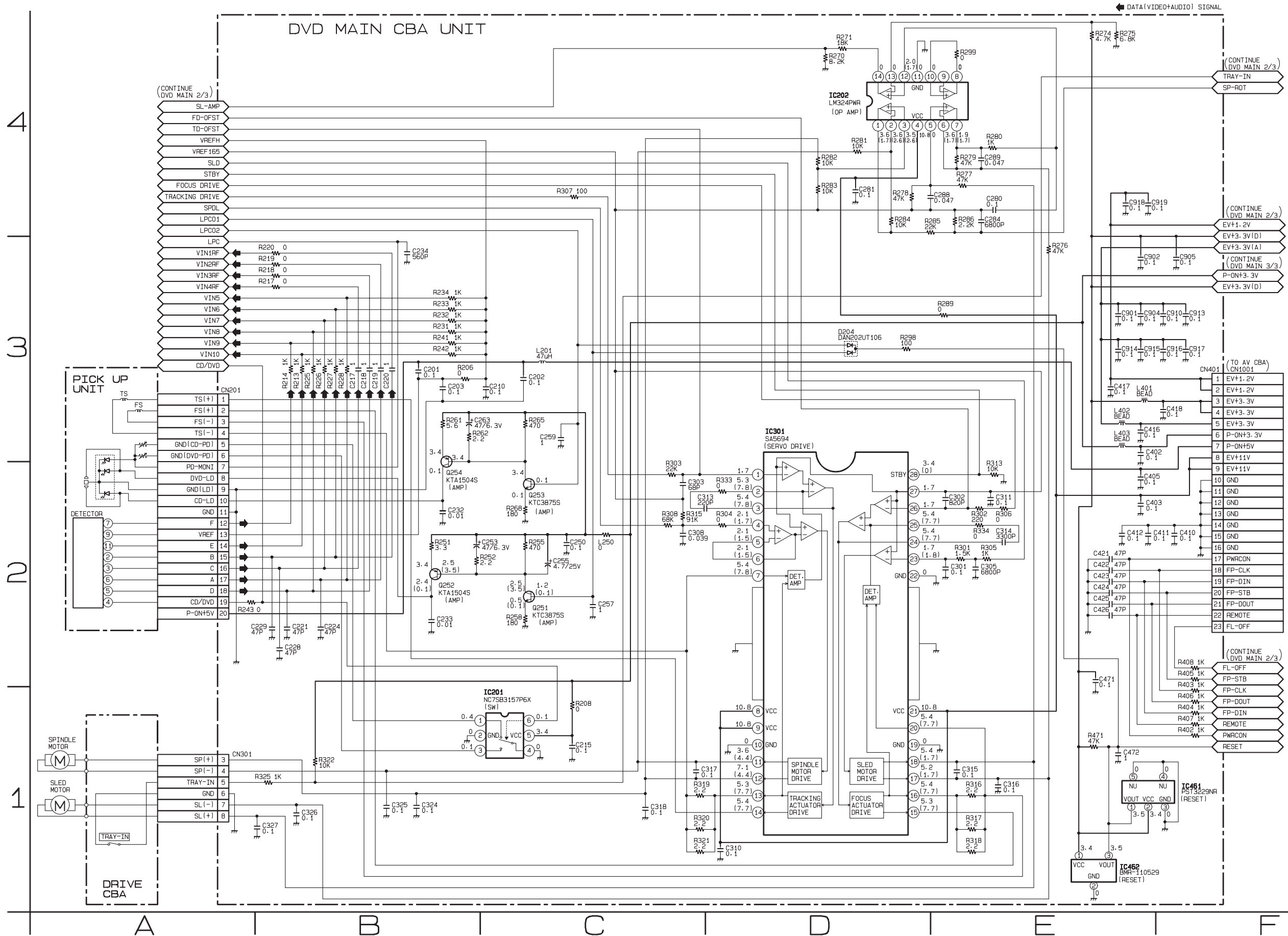

# DVD Main 2/3 Schematic Diagram

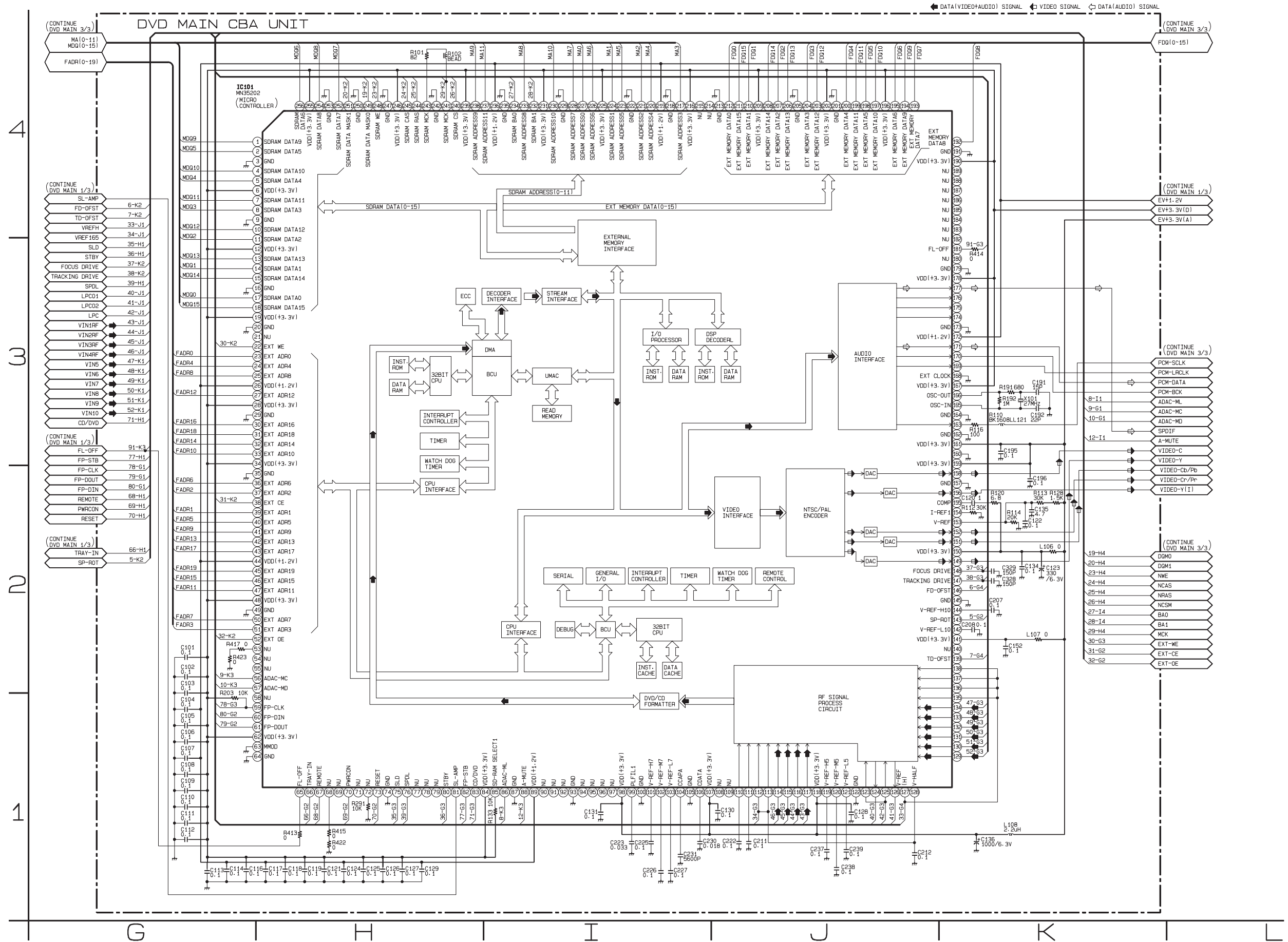

## IC101 VOLTAGE CHART

PIN.NO	PLAY	STOP	PIN.NO	PLAY	STOP	PIN.NO	PLAY	STOP	PIN.NO	PLAY	STOP	PIN.NO	PLAY	STOP	PIN.NO	PLAY	STOP	PIN.NO	PLAY	STOP	PIN.NO	PLAY	STOP
1	~	~	33	~	~	65	0	0	97	----	----	129	2.3	2.3	161	3.4	3.4	193	~	~	225	3.4	3.4
2	~	~	34	3.4	3.4	66	3.4	3.5	98	3.4	3.4	130	2.3	2.3	162	0	0	194	~	~	226	~	~
3	0	0	35	0	0	67	3.2	3.2	99	0.9	0.8	131	2.3	2.3	163	1.8	1.8	195	~	~	227	~	~
4	~	~	36	~	~	68	0	0	100	0	0	132	2.4	2.3	164	0	0	196	3.4	3.4	228	~	~
5	~	~	37	~	~	69	----	----	101	2.4	2.4	133	2.4	2.4	165	1.7	1.8	197	~	~	229	0	0
6	3.4	3.4	38	0.4	0.3	70	3.4	3.4	102	2.2	2.2	134	2.4	2.4	166	1.7	1.7	198	~	~	230	~	~
7	~	~	39	~	~	71	----	----	103	1.9	1.9	135	2.3	2.3	167	3.4	3.4	199	~	~	231	3.4	3.4
8	~	~	40	~	~	72	1.4	2.7	104	0.4	0.3	136	2.3	2.3	168	0	0	200	~	~	232	1.3	1.6
9	0	0	41	~	~	73	3.4	3.4	105	0	0	137	2.3	2.3	169	1.8	1.8	201	0	0	233	~	~
10	~	~	42	~	~	74	0	0	106	1.7	1.7	138	2.3	2.3	170	1.7	1.7	202	3.4	3.4	234	1.9	2.3
11	~	~	43	~	~	75	1.7	1.8	107	3.4	3.4	139	1.7	1.7	171	1.3	0.1	203	~	~	235	0	0
12	3.4	3.4	44	1.3	1.3	76	2.3	1.8	108	----	----	140	----	----	172	1.3	1.3	204	~	~	236	1.3	1.3
13	~	~	45	~	~	77	----	----	109	----	----	141	3.4	3.4	173	0	0	205	0	0	237	~	~
14	~	~	46	~	~	78	----	----	110	1.9	1.9	142	1.3	1.3	174	----	----	206	~	~	238	~	~
15	~	~	47	~	~	79	----	----	111	1.9	1.9	143	2.1	1.7	175	----	----	207	~	~	239	3.4	3.4
16	0	0	48	3.4	3.4	80	3.4	0.1	112	1.7	1.7	144	2.2	2.2	176	----	----	208	~	~	240	3.4	3.3
17	~	~	49	0	0	81	0.1	0.1	113	1.7	1.7	145	0	0	177	1.8	1.7	209	3.4	3.4	241	1.9	1.9
18	~	~	50	~	~	82	2.8	2.8	114	1.7	1.7	146	1.7	1.7	178	3.4	3.5	210	~	~	242	0	0
19	3.4	3.4	51	~	~	83	0.1	0.1	115	1.7	1.7	147	1.8	1.7	179	0	0	211	~	~	243	1.9	1.9
20	0	0	52	0.8	0.8	84	3.4	3.4	116	1.7	1.7	148	1.7	1.7	180	----	----	212	~	~	244	3.4	3.3
21	----	----	53	0	0	85	0.1	0.1	117	1.7	1.7	149	0.6	0.5	181	0	0	213	0	0	245	3.4	3.4
22	3.5	3.5	54	----	----	86	3.6	3.4	118	3.4	3.4	150	3.4	3.4	182	----	----	214	----	----	246	3.4	3.4
23	~	~	55	----	----	87	0	0	119	2.0	2.0	151	0.5	0.6	183	----	----	215	----	----	247	0	0
24	~	~	56	3.4	3.4	88	3.5	0.1	120	1.7	1.7	152	0.5	0.4	184	----	----	216	3.4	3.4	248	3.3	3.4
25	~	~	57	3.5	3.5	89	1.3	1.3	121	1.5	1.5	153	1.4	1.3	185	----	----	217	~	~	249	3.2	3
26	1.3	1.3	58	----	----	90	----	----	122	0	0	154	1.4	1.3	186	----	----	218	0	0	250	0	0
27	~	~	59	3.4	3.4	91	----	----	123	0.3	0.1	155	2.4	2.4	187	----	----	219	1.3	1.3	251	3.2	3.0
28	3.4	3.4	60	3.4	3.4	92	----	----	124	1.2	0.1	156	3.4	3.4	188	----	----	220	~	~	252	~	~
29	0	0	61	3.5	3.5	93	0	0	125	0.3	0.1	157	0	0	189	----	----	221	~	~	253	0	0
30	~	~	62	3.4	3.4	94	----	----	126	0.1	0.1	158	0.9	0.9	190	3.4	3.5	222	0	0	254	~	~
31	~	~	63	0	0	95	----	----	127	2.3	2.3	159	3.4	3.4	191	0	0	223	~	~	255	3.4	3.4
32	~	~	64	0	0	96	----	----	128	1.7	1.7	160	0	0	192	~	~	224	~	~	256	~	~



# DVD Main 3/3 Schematic Diagram

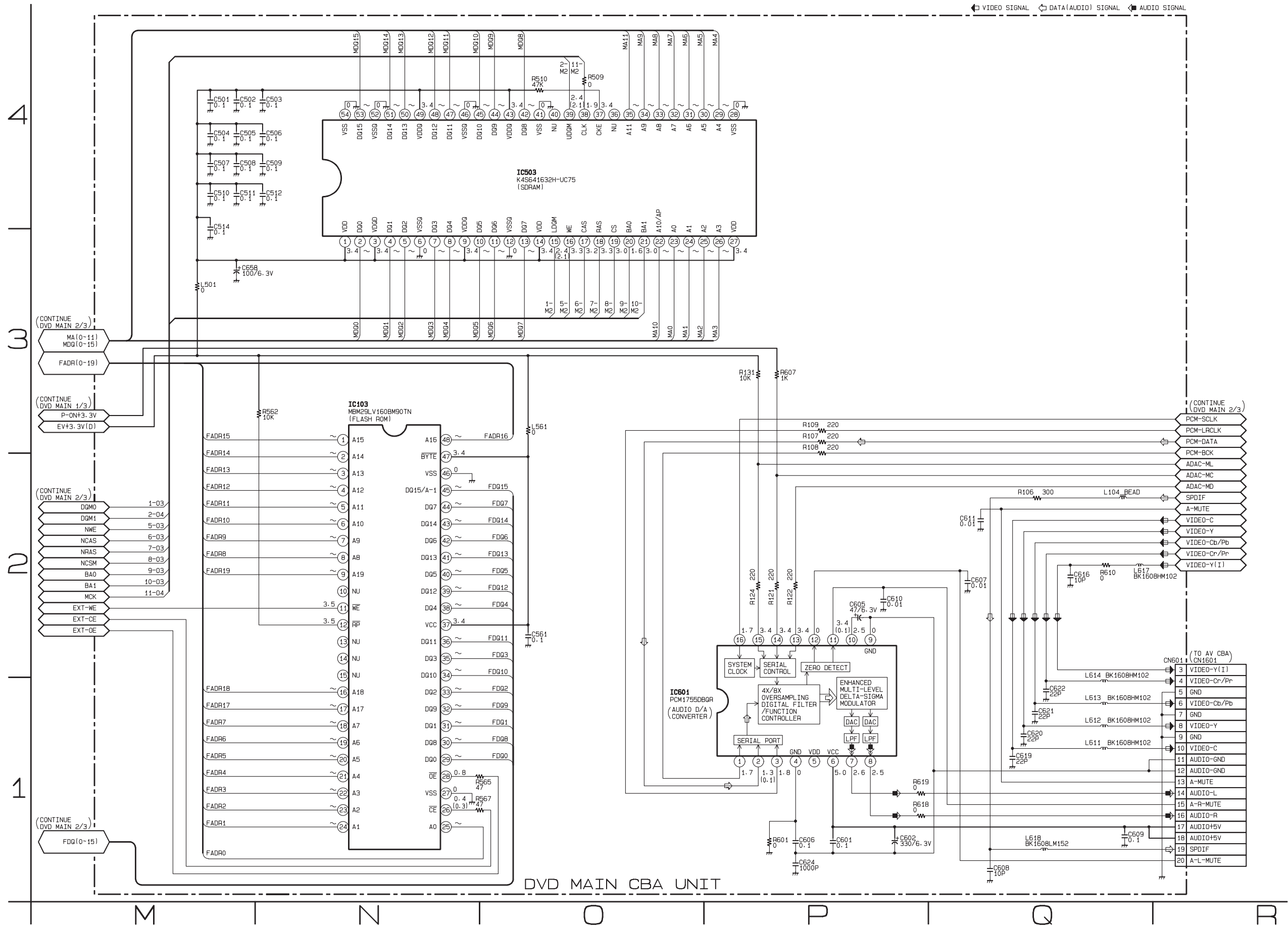

# AV 1/3 Schematic Diagram

## CAUTION !

Fixed voltage ( or Auto voltage selectable ) power supply circuit is used in this unit.  
If Main Fuse (F1001) is blown, check to see that all components in the power supply circuit are not defective before you connect the AC plug to the AC power supply.  
Otherwise it may cause some components in the power supply circuit to fail.

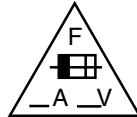

## CAUTION

FOR CONTINUED PROTECTION AGAINST FIRE HAZARD,  
REPLACE ONLY WITH THE SAME TYPE FUSE.  
ATTENTION : POUR UNE PROTECTION CONTINUE LES RISQUES  
D'INCELE N'UTILISER QUE DES FUSIBLE DE MÊME TYPE.

## RISK OF FIRE-REPLACE FUSE AS MARKED.



"This symbol means fast operating fuse."

"Ce symbole représente un fusible à fusion rapide."

## NOTE :

The voltage for parts in hot circuit is measured using hot GND as a common terminal.

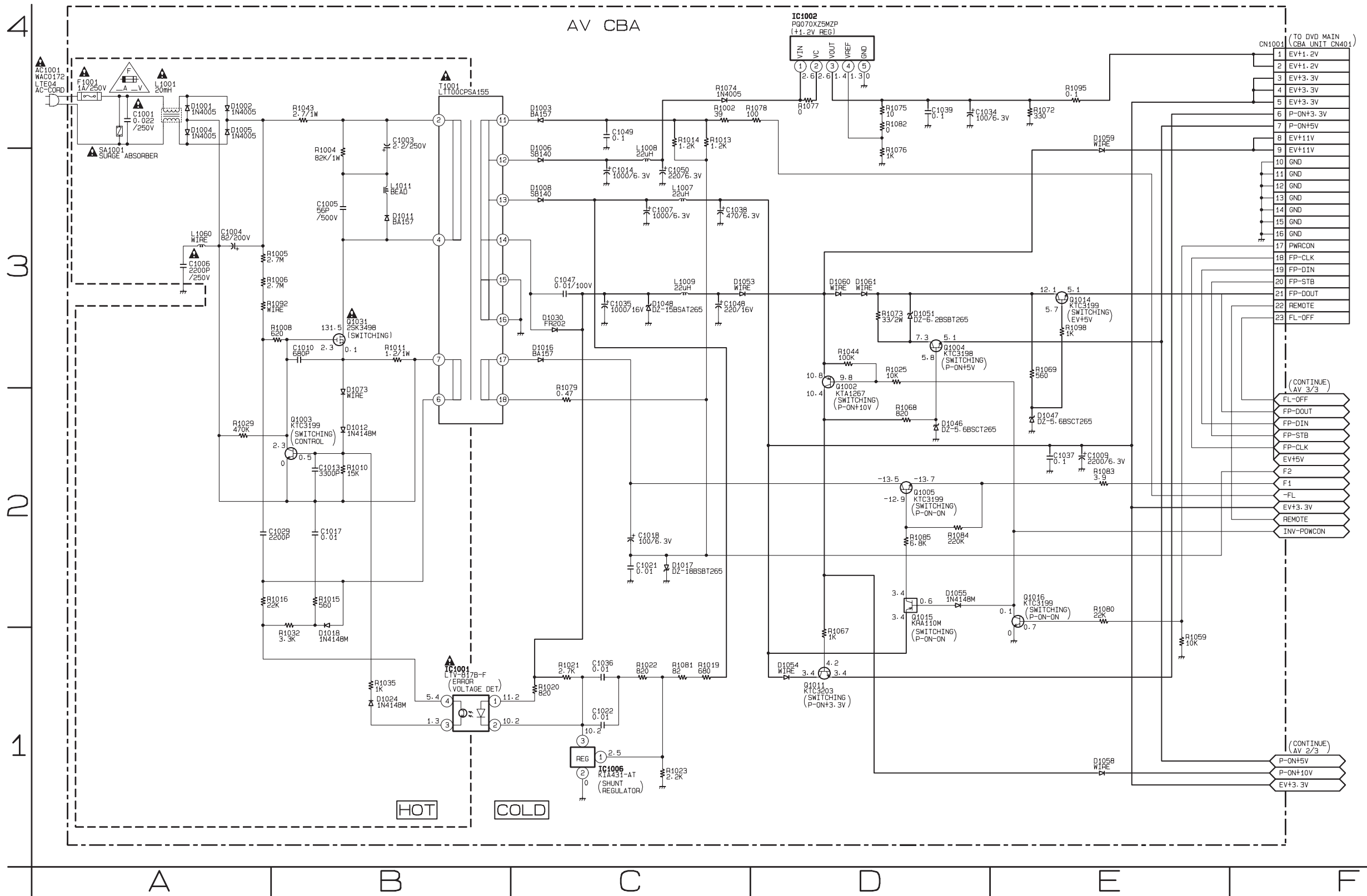

# AV 2/3 Schematic Diagram

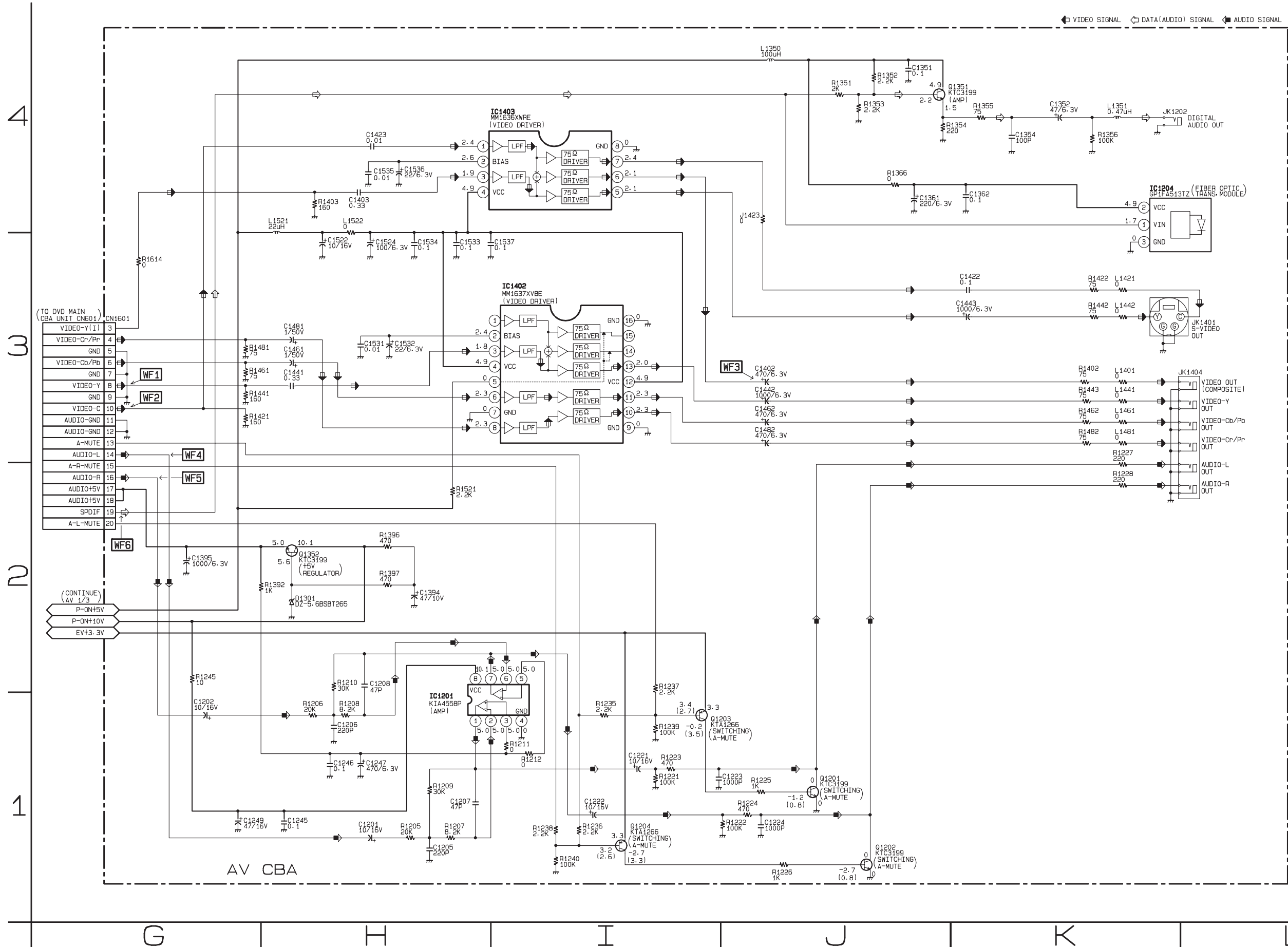

# AV 3/3 & Function Schematic Diagram

FL2001 MATRIX CHART

	7G	6G	5G	4G	3G	2G	1G
a		a	a	a	a	a	SACD
b	REPEAT	b	b	b	b	b	PSCAN
c	A-	c	c	c	c	c	DVD
d	B	d	d	d	d	d	A
e	ALL	e	e	e	e	e	P
f		f	f	f	f	f	M
g		g	g	g	g	g	HD
h		GROUP		CHP	TRK.	V	
i	i	TITLE	VCR		REC	CD	

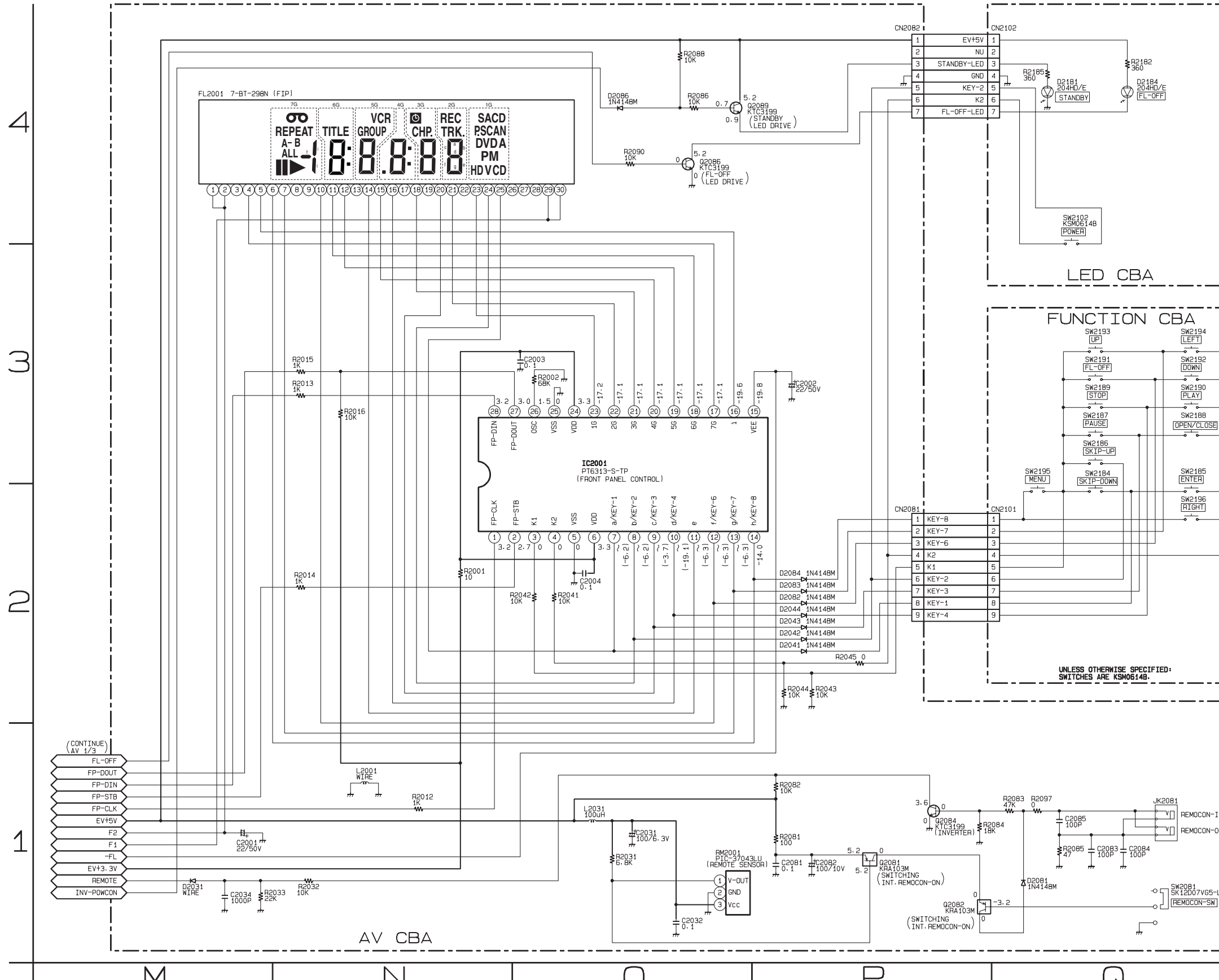

# AV CBA Top View

## CAUTION !

Fixed voltage ( or Auto voltage selectable ) power supply circuit is used in this unit.  
 If Main Fuse (F1001) is blown, check to see that all components in the power supply circuit are not defective before you connect the AC plug to the AC power supply.  
 Otherwise it may cause some components in the power supply circuit to fail.

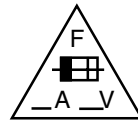

## CAUTION

FOR CONTINUED PROTECTION AGAINST FIRE HAZARD,  
 REPLACE ONLY WITH THE SAME TYPE FUSE.  
 ATTENTION : POUR UNE PROTECTION CONTINUE LES RISQUES  
 D'INCELE N'UTILISER QUE DES FUSIBLE DE MÊME TYPE.  
**RISK OF FIRE-REPLACE FUSE AS MARKED.**



"This symbol means fast operating fuse."

"Ce symbole représente un fusible à fusion rapide."

## NOTE :

The voltage for parts in hot circuit is measured using hot GND as a common terminal.

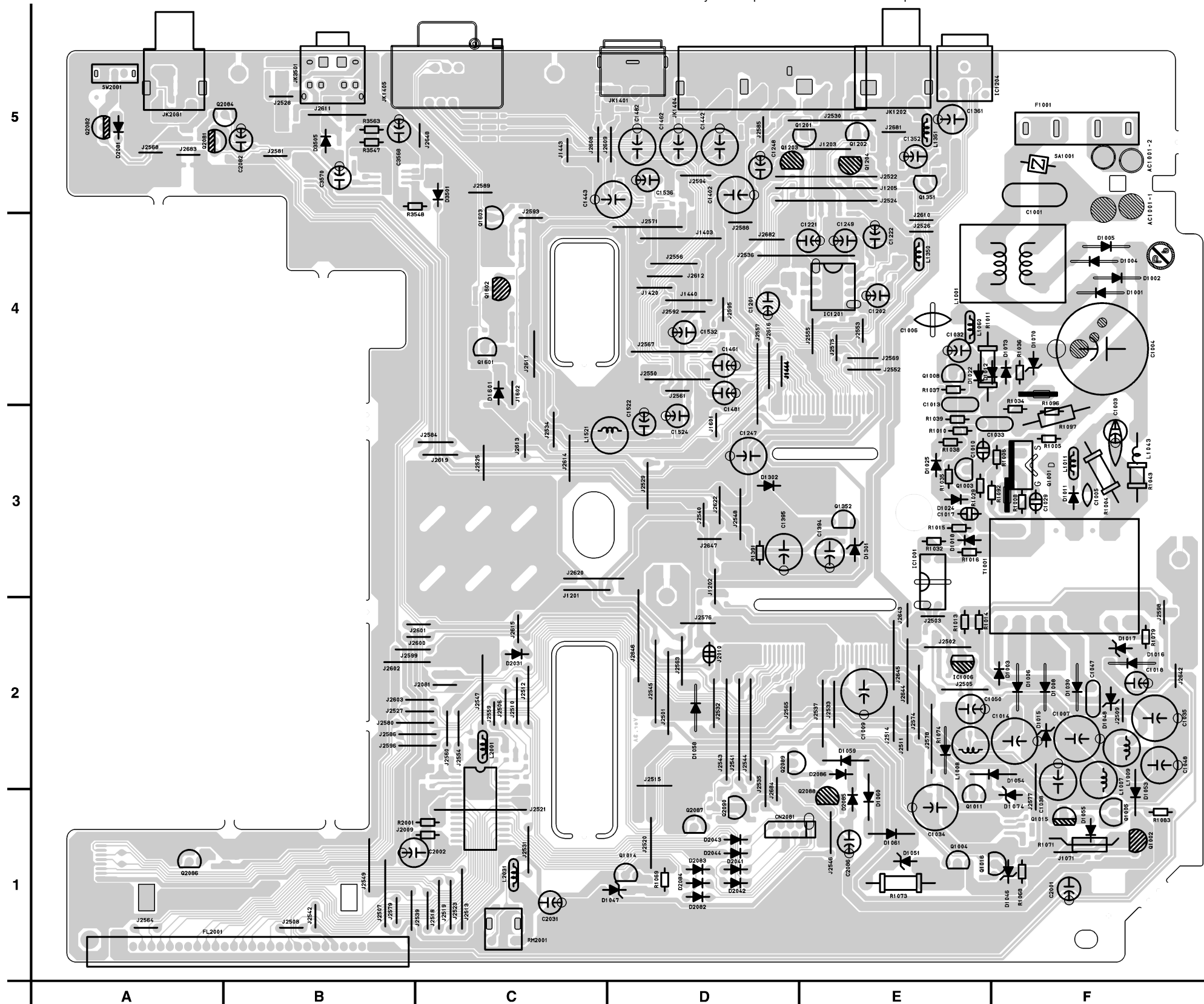

# AV CBA Bottom View

## CAUTION !

Fixed voltage ( or Auto voltage selectable ) power supply circuit is used in this unit.  
If Main Fuse (F1001) is blown, check to see that all components in the power supply circuit are not defective before you connect the AC plug to the AC power supply.  
Otherwise it may cause some components in the power supply circuit to fail.

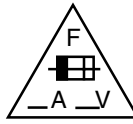

## CAUTION

FOR CONTINUED PROTECTION AGAINST FIRE HAZARD,  
REPLACE ONLY WITH THE SAME TYPE FUSE.

ATTENTION : POUR UNE PROTECTION CONTINUE LES RISQUES  
D'INCELE N'UTILISER QUE DES FUSIBLE DE MÊME TYPE.

**RISK OF FIRE-REPLACE FUSE AS MARKED.**



"This symbol means fast operating fuse."

"Ce symbole représente un fusible à fusion rapide."

## NOTE :

The voltage for parts in hot circuit is measured  
using hot GND as a common terminal.

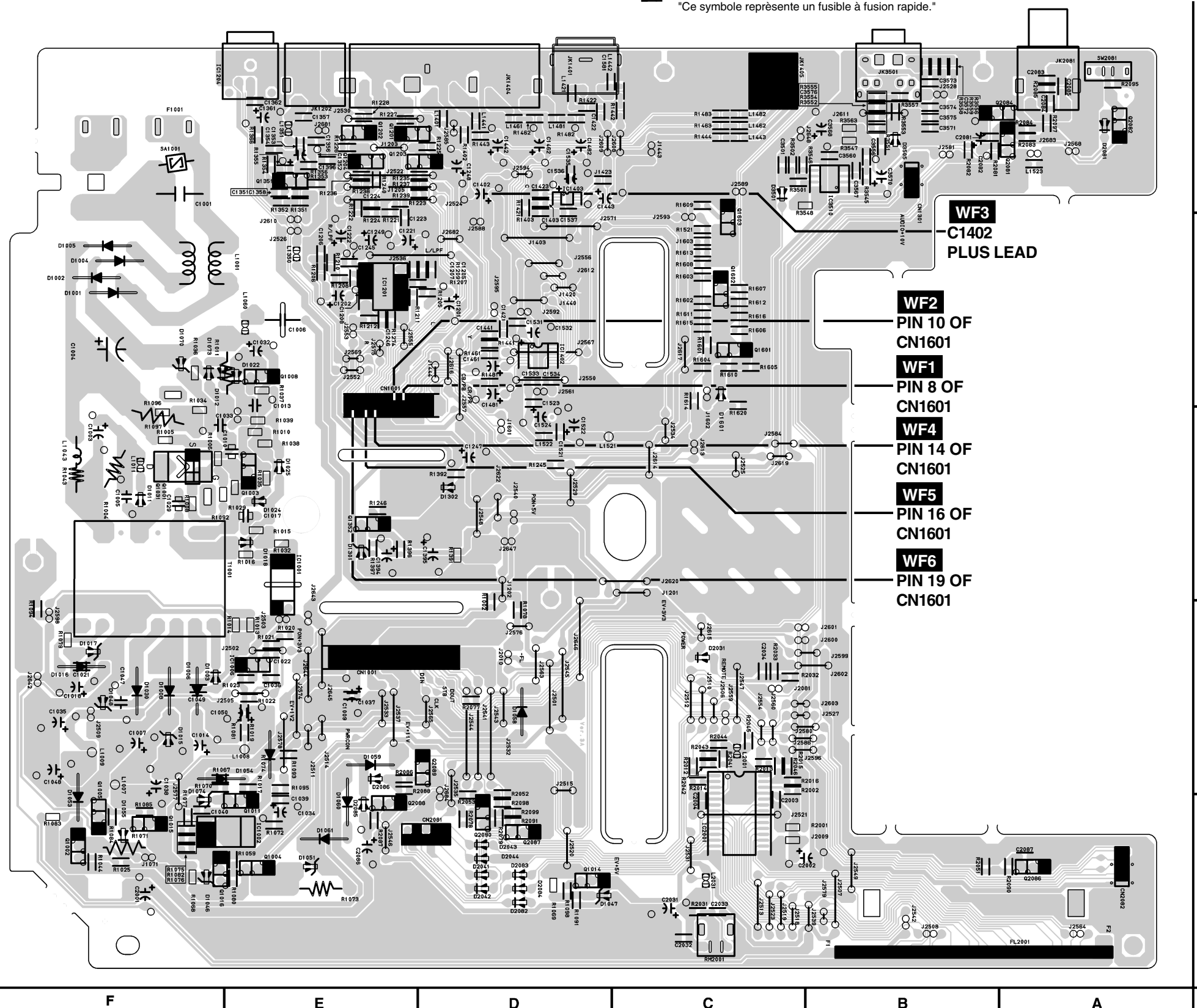

**WF3**  
C1402  
PLUS LEAD

**WF2**  
PIN 10 OF  
CN1601

**WF1**  
PIN 8 OF  
CN1601

**WF4**  
PIN 14 OF  
CN1601

**WF5**  
PIN 16 OF  
CN1601

**WF6**  
PIN 19 OF  
CN1601

### FUNCTION CBA Top View

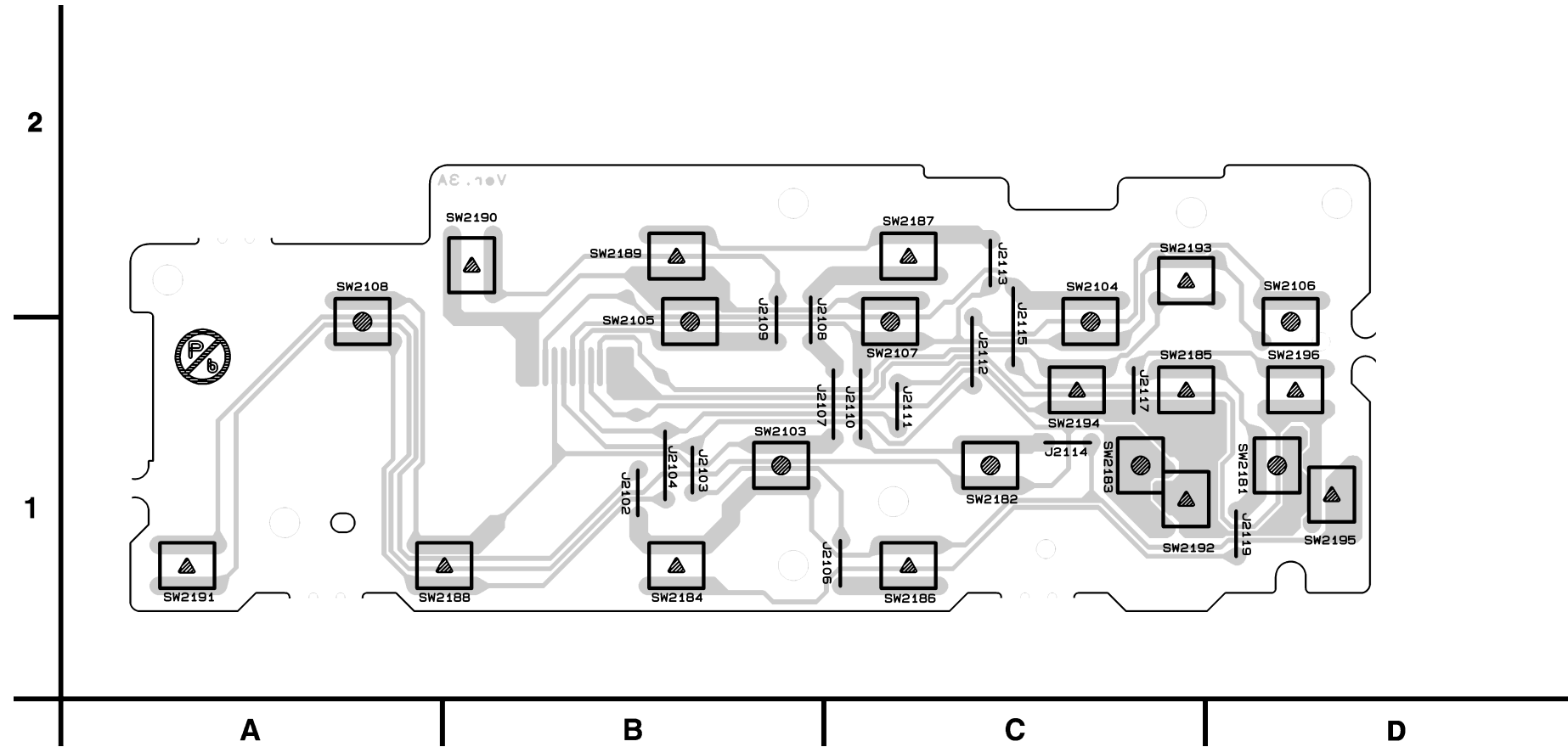

### FUNCTION CBA Bottom View

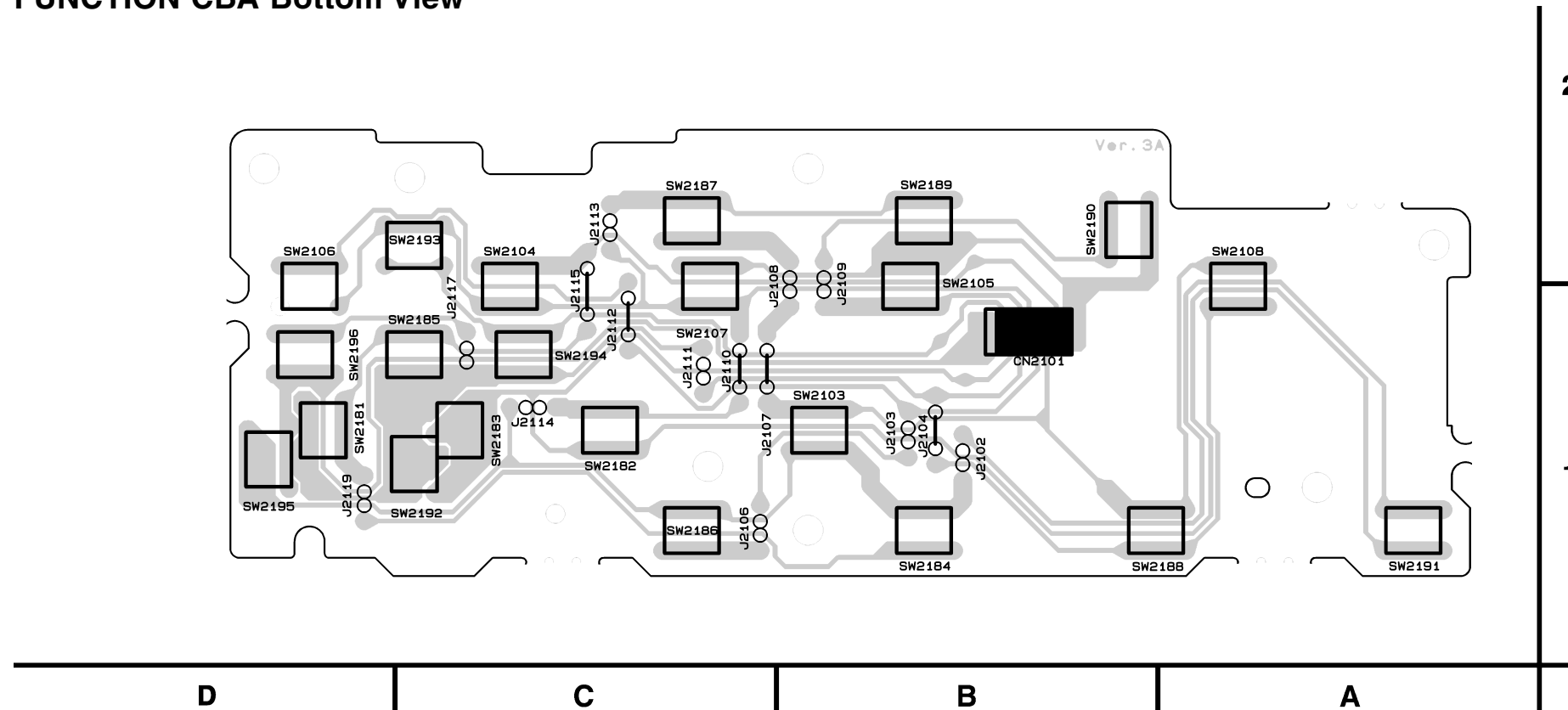

### LED CBA Top View

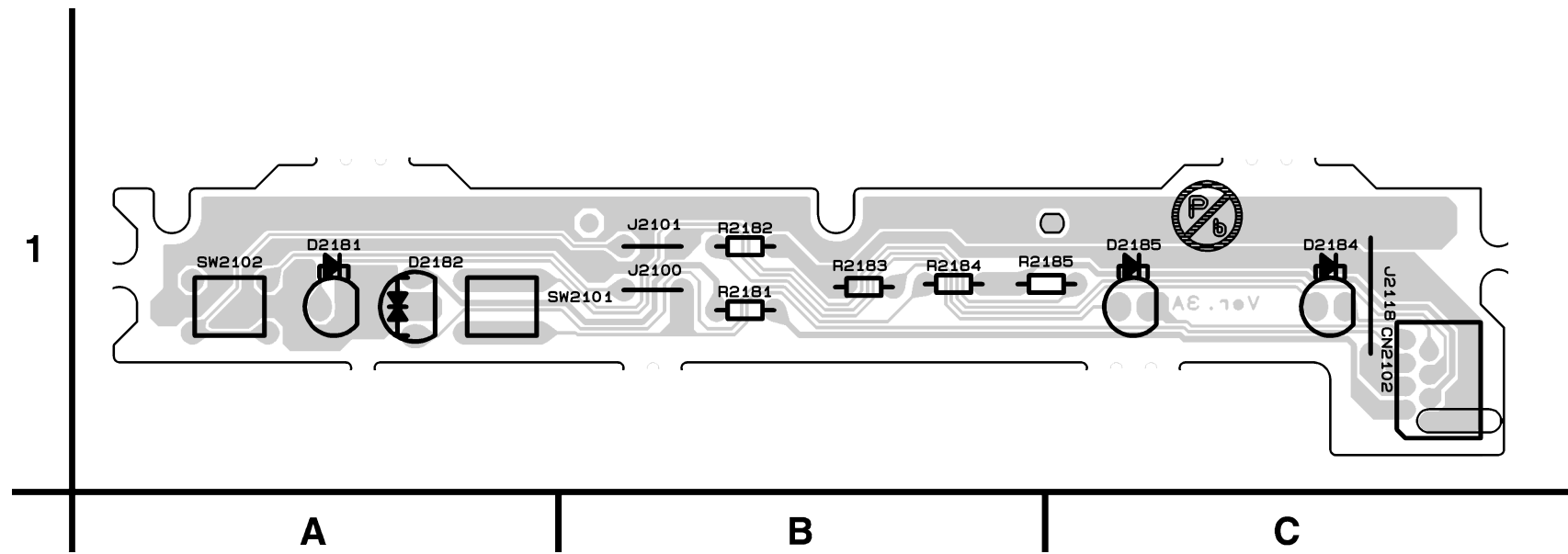

### LED CBA Bottom View

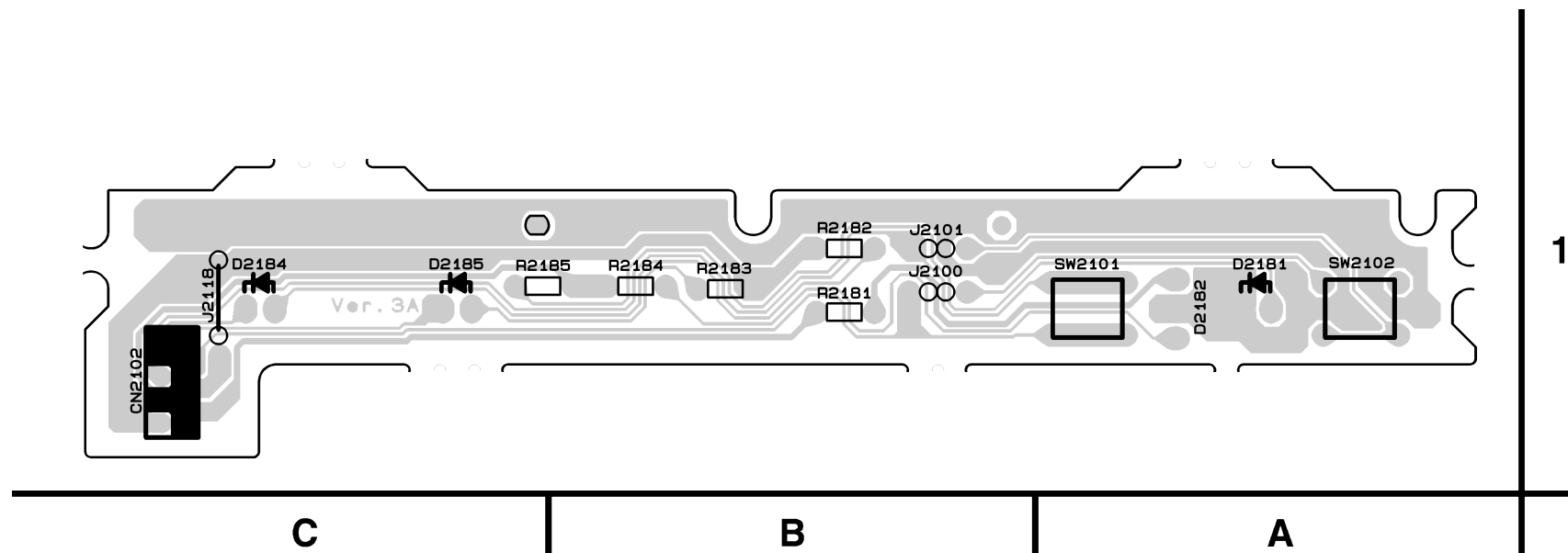



# WAVEFORMS

**WF1** Pin 8 of CN1601

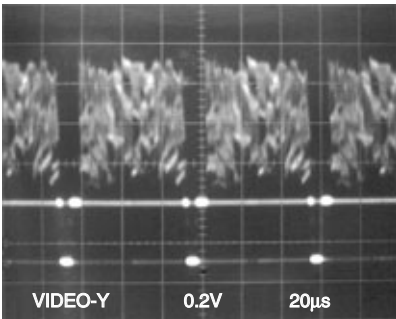

**WF5** Pin 16 of CN1601

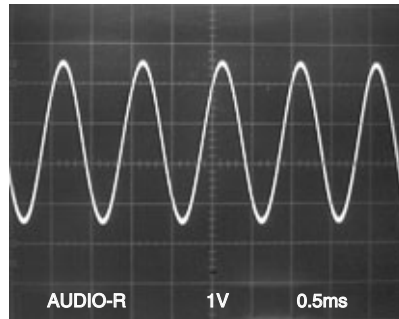

**WF2** Pin 10 of CN1601

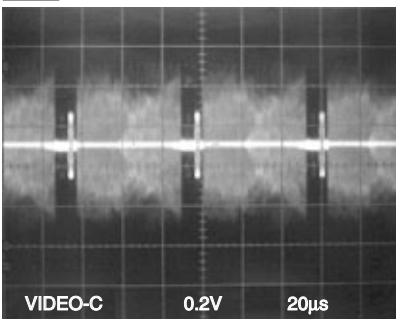

**WF6** Pin 19 of CN1601

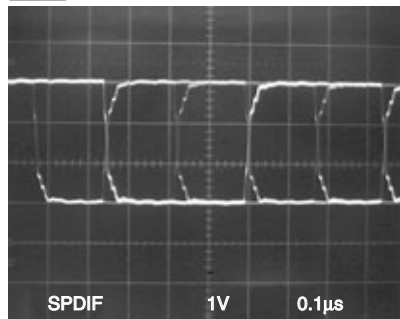

**WF3** C1402 PLUS LEAD

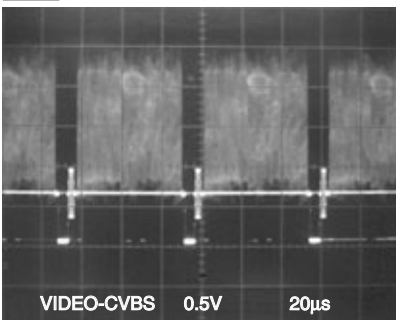

## NOTE:

Input

CD: 1kHz PLAY  
(WF4~WF6)

DVD: POWER ON (STOP) MODE  
(WF1~WF3)

**WF4** Pin 14 of CN1601

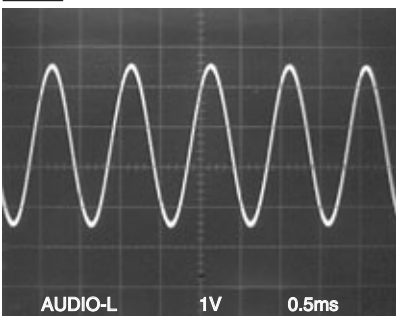

# WIRING DIAGRAM

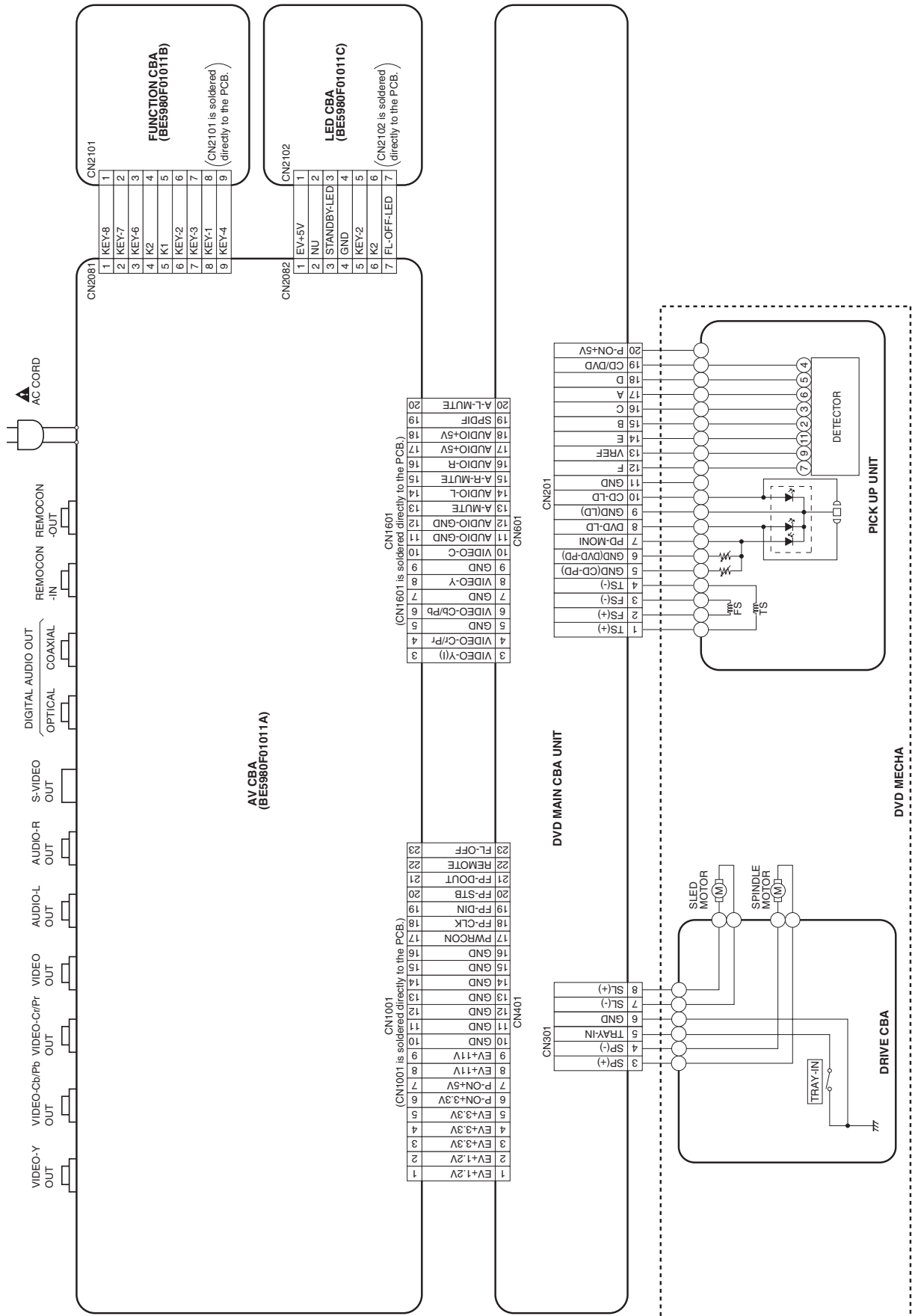

# FIRMWARE RENEWAL MODE

1. Turn the power on and remove the disc on the tray.
2. To put the DVD player into version up mode, press [9], [8], [7], [6], and [SEARCH MODE] buttons on the remote control unit in that order. The tray will open automatically.

Fig. a appears on the screen and Fig. b appears on the VFD.

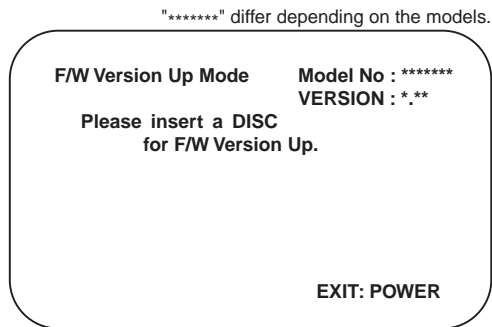

Fig. a Version Up Mode Screen

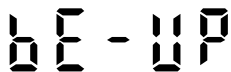

Fig. b VFD in Version Up Mode

The DVD player can also enter the version up mode with the tray open. In this case, Fig. a will be shown on the screen while the tray is open.

3. Load the disc for version up.
4. The DVD player enters the F/W version up mode automatically. Fig. c appears on the screen and Fig. d appears on the VFD. If you enter the F/W for different models, "Disc Error" will appear on the screen, then the tray will open automatically.

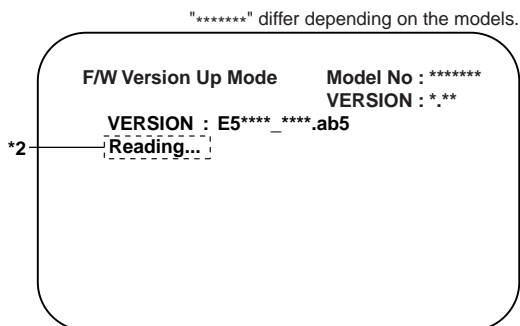

Fig. c Programming Mode Screen



Fig. d VFD in Programming Mode (Example)

The appearance shown in (\*2) of Fig. c is described as follows:

No.	Appearance	State
1	Reading...	Sending files into the memory
2	Erasing...	Erasing previous version data
3	Programming...	Writing new version data

5. After programming is finished, the tray opens automatically. Fig. e appears on the screen and the

checksum in (\*3) of Fig. e appears on the VFD. (Fig. f)

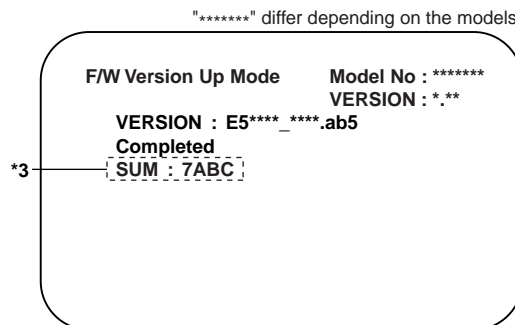

Fig. e Completed Program Mode Screen



Fig. f VFD upon Finishing the Programming Mode (Example)

At this time, no buttons are available.

6. Remove the disc on the tray.
7. Unplug the AC cord from the AC outlet. Then plug it again.
8. Turn the power on by pressing the power button and the tray will close.
9. Press [1], [2], [3], [4], and [DISPLAY] buttons on the remote control unit in that order. Fig. g appears on the screen.

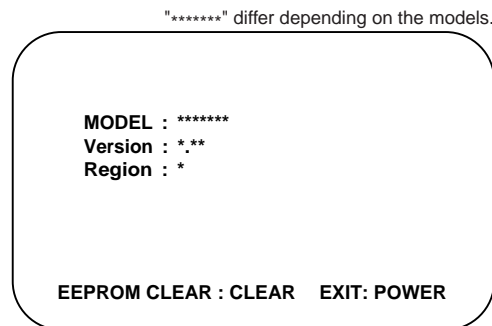

Fig. g

10. Press [CLEAR] button on the remote control unit. Fig. h appears on the screen.

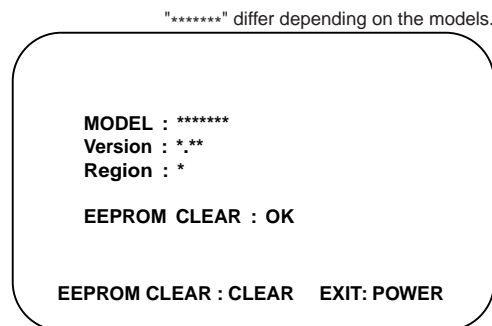

Fig. h

When "OK" appears on the screen, the factory default will be set. Then the firmware renewal mode is complete.

11. To exit this mode, press [POWER] button.

# IC PIN FUNCTION DESCRIPTIONS

## IC2001 [ PT6313-S-TP ]

Pin No.	IN/ OUT	Signal Name	Name Function
1	IN	FP-CLK	Clock Input
2	IN	FP-STB	Serial Interface Strobe
3	IN	K1	Key Data 1 Input
4	IN	K2	Key Data 2 Input
5	-	VSS	GND
6	-	VDD	Power Supply
7	OUT	a / KEY-1	Segment Output / Key Source-1
8	OUT	b / KEY-2	Segment Output / Key Source-2
9	OUT	c / KEY-3	Segment Output / Key Source-3
10	OUT	d / KEY-4	Segment Output/ Key Source-4
11	OUT	e	Segment Output
12	IN	f / KEY-6	Segment Output/ Key Source-6
13	IN	g / KEY-7	Segment Output/ Key Source-7
14	OUT	h / KEY-8	Segment Output/ Key Source-8
15	-	VEE	Pull Down Level
16	OUT	i	Segment Output
17	OUT	7G	Grid Output
18		6G	
19		5G	
20		4G	
21		3G	
22		2G	
23		1G	
24	-	VDD	Power Supply
25	-	VSS	GND
26	IN	OSC	Oscillator Input
27	OUT	FP-DOUT	Serial Data Output
28	IN	FP-DIN	Serial Data Input

# LEAD IDENTIFICATIONS

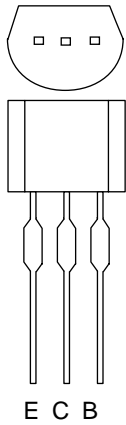

2SA1015-Y(TPE2)  
 2SC2120-Y(TPE2)  
 KTA1266(Y)  
 KTC3203(Y)  
 KTC3198(Y)  
 2SC2236-Y-TPE6,C

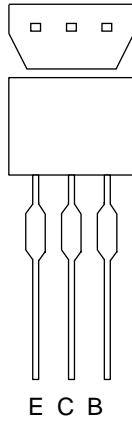

2SC2785(H)  
 BN1L3Z(P)  
 KRA110M  
 KTA1267(Y)  
 KTC3199(GR)  
 BN1F4M-T  
 KRA103M  
 KTA1266(GR)

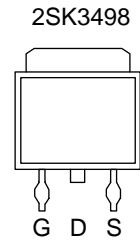

2SK3498

KIA4558P  
 MM1636XWRE

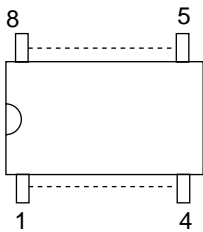

NJM4558D

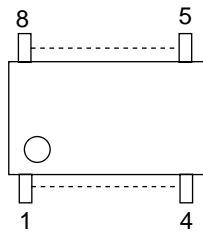

PT6313-S-TP  
 SC16313

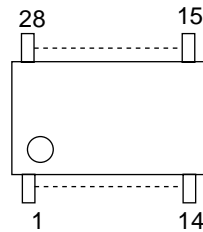

FAN431AZXA  
 KIA431-AT

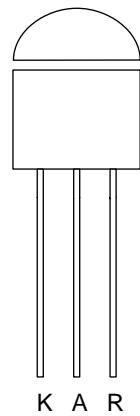

MM1637XVBE

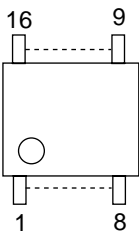

PQ070XZ5MZP

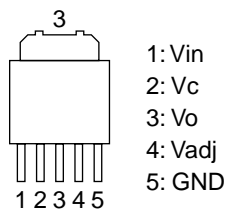

1: Vin  
 2: Vc  
 3: Vo  
 4: Vadj  
 5: GND

LTV-817B-F  
 LTV-817C-F  
 PS2561A-1(Q,W)



GP1FA513TZ  
 0C-0805T\*002

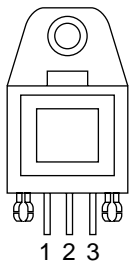

**Note:**  
 A: Anode  
 K: Cathode  
 E: Emitter  
 C: Collector  
 B: Base  
 R: Reference  
 G: Gate  
 D: Drain  
 S: Source

# EXPLODED VIEWS

## Cabinet

See Electrical Parts List for parts with this mark.

Some Ref. Numbers are not in sequence.

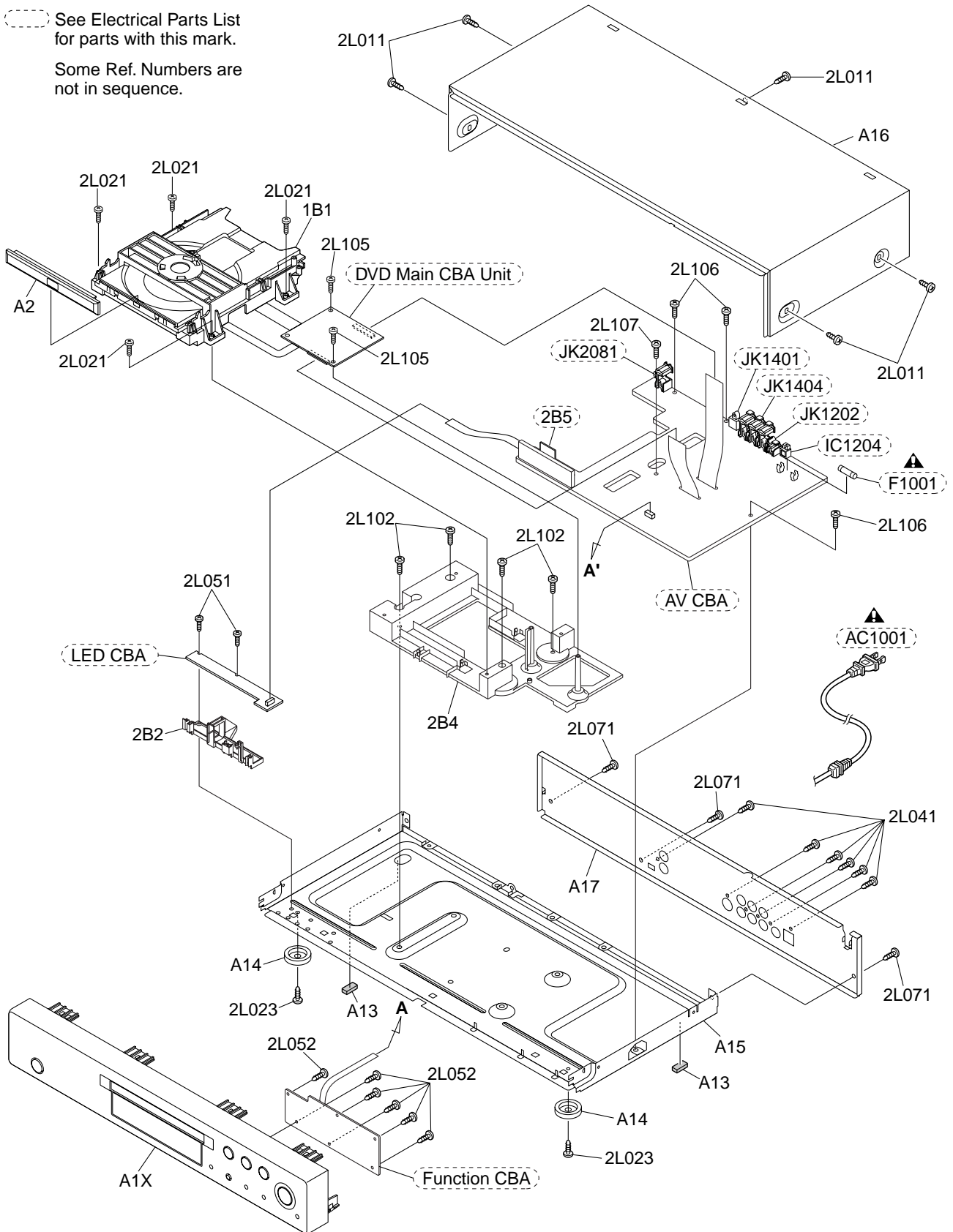

# Packing

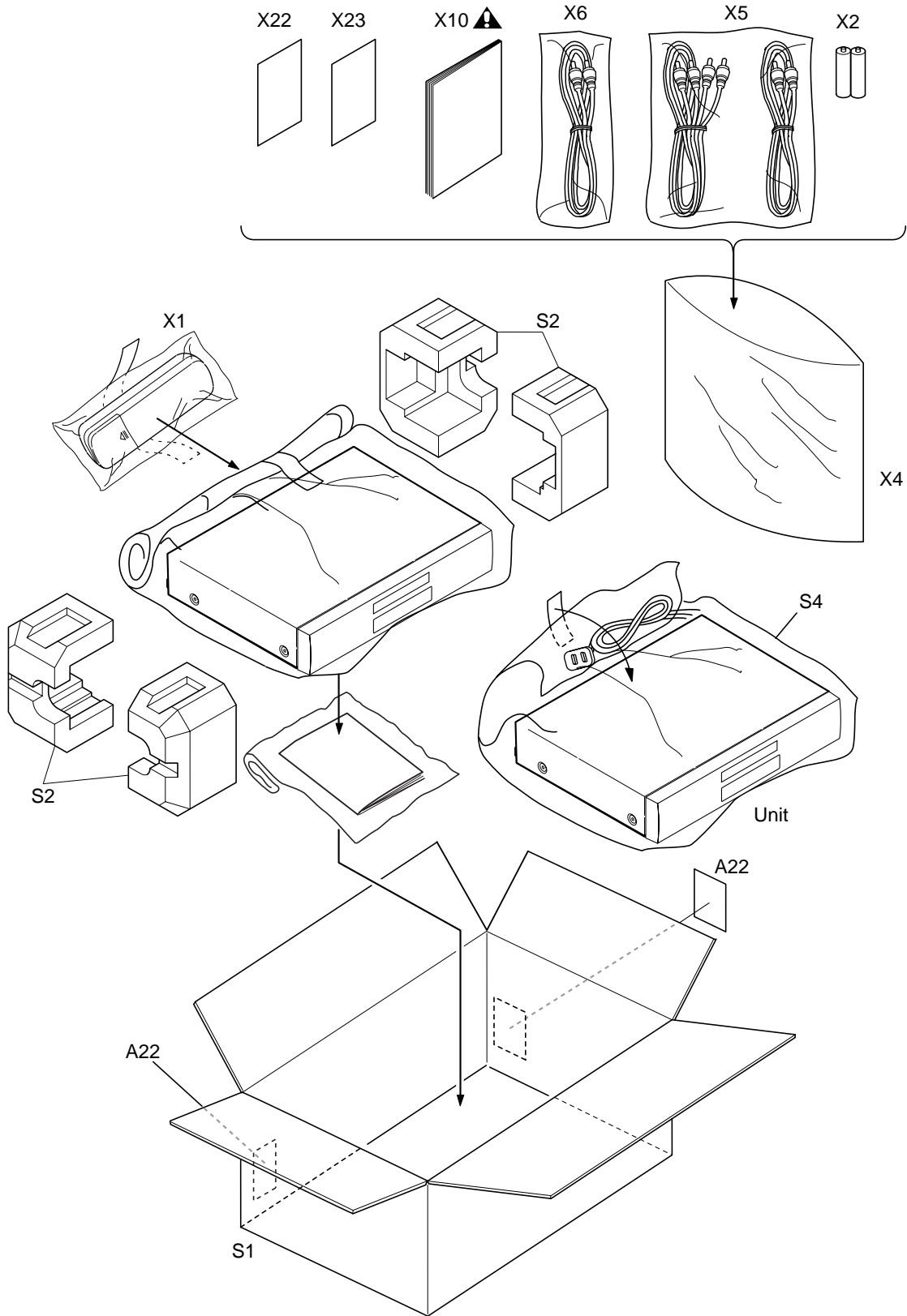

# PARTS LIST

POS. NO.	VERS. COLOR	PART NO. (FOR EUR)	PART NO. (MJI)	PART NAME	DISCRIPTION
<b>EXPLODED VIEW PARTS</b>					
A1X	/U1B		00M12BW248510	PANEL	FRONT ASSEMBLY BLACK 1VM220042
A1X	/U1S		00M12BW248530	PANEL	FRONT ASSEMBLY SILVER 1VM220044
A2	/U1B		00M44AW063010	ESCUTCHEON	TRAY PANEL BLACK 0VM204372
A2	/U1S		00M44AW063210	ESCUTCHEON	TRAY PANEL SILVER 0VM416014
A13			00M44AW057020	LEG	FOOT(REAR) DV4500 0VM415007
A14	/U1B		00M44AW057010	LEG	LEG ASSY BLACK GOLD 0VM415913
A14	/U1S		00M44AW057210	LEG	LEG ASSY SILVER 0VM416056
A15			nsp	CHASSIS	MAIN CHASSIS DV4500 0VM101362
A17			nsp	PANEL	REAR PANEL DV4500 FOR U 1VM220061
1B1			00M12BW304010	MECHANISM	DVD MECHA(FG LESS) 0838 VCZL0500 N79F0HVM
			90M-ZZ002540R	PCB ASSY	DVD MAIN CBA UNIT N79B1HUP
			90M-ZZ002550R	PCB ASSY	AV CBA ASSY / FUNCTION CBA ASSY / LED CBA ASSY 1VSA10394
▲ AC1001	/U		90M-YC000840R	MAINS CORD	! MAINS CORD A0A0280-007 WAC0172LTE04 OR PB8K9F9110A-057 OR WAC0172LW008
<b>PACKING</b>					
X1			00MZK12BW0010	UNIT KIT	REMOTE CONTROLLER RC6500DV NA819ED
X10			00M12BW851250	USER GUIDE	USER GUIDE DV4500 FOR U 1VMN20139
<b>NOT STANDARD SPARE PARTS</b>					
A16	/U1B		00M44AW257010	LID	TOP COVER BLACK 0VM101038B
A16	/U1S		00M44AW257210	LID	TOP COVER SILVER 0VM305312C
S1			00M12BW801010	CARTON BOX	GIFT BOX CARTON DV4500 1VM320178
S2			00M44AW809010	CUSHION	CUSHION DV4500 0VM101316
<b>ELECTRICAL PARTS</b>					
<b>AV CBA</b>					
C1001			90M-DF100400R	FILM CAP.	0.022UF/250V M CT2E223MS037 OR 0.022UF/250V K OR CT2E223DC011 OR 0.022UF/275V K OR CT2E223HJE13
▲ C1006			90M-DK100850R	CERAMIC CAP.	! SAFETY CAP. 2200PF/250V CCN2EMA0E222 OR CA2E222MR049
CN1001			90M-YU001620R	FPC	23P FFC AV PCB TO MAIN WX1E59M2-003
CN1601			90M-YU001660R	FPC	18P FFC AV PCB TO MAIN WX1E5925-002
CN2082			90M-YU001640R	FPC	7P FFC AV PCB TO IND PCB WX1E59M2-001
▲ F1001			90M-FS001140R	FUSE	! FUSE 1A/250V PAGA20CW3102 OR
IC1204			90M-YJ002710R	OPT. CONNECTOR	OPTIC TRANS.MODULE GP1FA513TZ JWHHA00SH005
JK1202			90M-YT003370R	TERMINAL	CINCH (BLACK) MSP-251V-01 NI JXRL010LY070
JK1401			90M-YT003380R	TERMINAL	S TYPE JACK MDC-050V-2.4 JXEL040LY001
JK1404			90M-YT003850R	TERMINAL	CINCH MSP-246V34-65NI-FELF JXRL060LY082 OR MSD-246V-65NI/PBSN OR JXRL060LY069
JK2081			90M-YT003860R	TERMINAL	CINCH 2PIN (ORANGE) MSD-242V-24 NI JXRL020LY105
▲ L1001			90M-FN000200R	FILTER	! LINE FILTER 20MH SA-00911 LLBG00ZSA003 OR 03905 OR LLBG00ZKT008 OR MUV105-1126/M0021A OR LLBG00ZMMT01
▲ SA1001			90M-HV000050R	VARISTOR	! PVR-10D471KB NVQZ10D471KB OR CNR-10D471K OR NVQZR10D471K
SW2081			90M-SS000760R	SWITCH	SLIDE SWITCH SK12D07VG5-L A SSS0102LY003
▲ T1001			90M-TP000080R	TRANSF.	! PULSE TRANS CGS-SW0005A LTT00CPSA155 OR 04715 OR LTT00CPKT128
<b>FUNCTION CBA</b>					
CN2101			90M-YU001650R	FPC	9P FFC AV PCB TO FNT PCB WX1E59M2-002

NOTE : "nsp" PARTS IS LISTED FOR REFERENCE ONLY, MARANTZ WILL NOT SUPPLY THESE PARTS.

## NOTE ON SAFETY :

Symbol ▲ Fire or electrical shock hazard. Only original parts should be used to replaced any part marked with symbol ▲. Any other component substitution (other than original type), may increase risk of fire or electrical shock hazard.

## 安全上の注意 :

▲がついている部品は、安全上重要な部品です。必ず指定されている部品番号の部品を使用して下さい。