



4300



marantz

model 4300

Stereo 2 + Quadradial 4 Receiver

TABLE OF CONTENTS

SECTION	PAGE
Introduction	1
Service Notes	1
AM Tuner	1
FM Tuner	2
Phono and Pre-Amplifier	5
Dolby Unit	6
400Hz Tone	7
Dolby Switch	7
Record Level (L) (R)	7
Play Cal. (L) (R)	7
Dolby FM Preset Level Controls	8
400Hz Tone Switch	8
FM De-Emphasis Switch	8
Power Amplifier	8
BTL (Balanced Transformer-less) Connection	8
Power Supply Unit	8
Audio Trouble Analysis	8
Test Equipment Required for Servicing	9
AM Alignment Procedure	10
FM Alignment Procedure	10
Audio Adjustment	11
Automatic Voltage Regulator Adjustment	12
Dolby Alignment Procedures	12
Alignment Procedures of Dolby FM Preset Level Controls	13
Explanation of the Dolby Processing Chart	13
Parts List	28 ~ 45
Technical Specifications	46, 47

LIST OF ILLUSTRATIONS

FIGURE	PAGE
1. Block Diagram of the HA1156	4
2. Dial Stringing	11
3. Dolby Alignment Implement Simplified Schematic	12
4. Front Panel Adjustment and Component Locations	15
5. Main Chassis Component Locations (Bottom View)	15
6. Rear Panel Adjustment and Component Locations	16
7. Main Chassis Component Locations (Top View)	16
8. FM Front End Assembly P100 Component Locations	17
9. AM Tuner Assembly P150 Component Locations	17
10. FM IF Amplifier Assembly P200 Component Locations	17
11. MPX Stereo Decoder, Noise and DC Amplifier Assembly P300 Component Locations	18
12. Phono Amplifier Assembly P400 Component Locations	18
13. Vari-Matrix Assembly P500 Component Locations	19
14. Dolby Unit Assembly P600 Component Locations	19
15. Power Amplifier Assembly P700 Component Locations	20
16. Power Supply Assembly P800 Component Locations	21
17. FM Cal. Assembly PC01 Component Locations	21

18.	Tone Amplifier Assembly PD01 Component Locations	21
19.	Buffer and Pre-Amplifier Assembly PE01 Component Locations	22
20.	Tone Control Unit Assembly PF01 Component Locations	22
21.	Balance Control Unit Assembly PG01 Component Locations	22
22.	400Hz Oscillator and Meter Driver Assembly PL01 Component Locations	23
23.	Phase Convertor Assembly PM01 Component Locations	23
24.	Speaker Protector Assembly PN01 Component Locations	23
25.	Switch Unit Assembly PS01 Component Locations	23
26.	FM De-emphasis Assembly PU01 Component Locations	24
27.	Dolby Terminal Assembly PV01 Component Locations	24
28.	Headphone Assembly PW01 Component Locations	24
29.	Selector Lamps Assembly PY01 Component Locations	24
30.	Dial Lamps Assembly PZ01 Component Locations	24
31.	Exploded Mechanical Diagram	26, 27
32.	Schematic Diagram	48

TABLE

PAGE

1.	Test Equipment Required for Servicing	9
2.	Dolby Processing Chart	14

INTRODUCTION

This service manual was prepared for use by Authorized Warranty Stations and contains service information for Marantz Model 4300 Stereo 2+Quadradial 4 Receiver.

Servicing information and voltage data included in this manual are intended for use by the knowledgeable and experienced technician only. All instruction should be read carefully. No attempt should be made to proceed without a good understanding of the operation in the receiver.

The parts list furnish information by which replacement part may be ordered from the Marantz Company. A simple description is included for parts which can be usually be obtained through local suppliers.

1. SERVICE NOTES

As can be seen from the circuit diagram, the chassis of Model 4300 consists of following units. Each unit mounted on a printed circuit board is described within the square enclosed by a bold dotted line on the circuit diagram.

1. FM Front End	mounted on P.W. Board, P100
2. AM Tuner	mounted on P.W. Board, P150
3. FM IF Amplifier	mounted on P.W. Board, P200
4. MPX Stereo Decoder, Noise and DC Amplifier	mounted on P.W. Board, P300
5. Phono Amplifier	mounted on P.W. Board, P400
6. Vari-Matrix	mounted on P.W. Board, P500
7. Dolby Unit	mounted on P.W. Board, P600
8. Power Amplifier	mounted on P.W. Board, P700
9. Power Supply	mounted on P.W. Board, P800
10. FM CAL.	mounted on P.W. Board, PC01
11. Tone Amplifier	mounted on P.W. Board, PD01
12. Buffer and Pre-Amplifier	mounted on P.W. Board, PE01
13. Tone Control Unit	mounted on P.W. Board, PF01
14. Balance Control Unit	mounted on P.W. Board, PG01
15. 400Hz Oscillator and Meter Driver	mounted on P.W. Board, PL01
16. Phase Convertor	mounted on P.W. Board, PM01
17. Speaker Protector	mounted on P.W. Board, PN01
18. Switch Unit	mounted on P.W. Board, PS01
19. FM De-emphasis	mounted on P.W. Board, PU01
20. Dolby Terminal	mounted on P.W. Board, PV01
21. Head Phones	mounted on P.W. Board, PW01
22. Selector Lamps	mounted on P.W. Board, PY01
23. Dial Lamps	mounted on P.W. Board, PZ01

2. AM TUNER

The AM TUNER portion of the 4300 is composed of one IC circuit (including RF amplifier, local oscillator, mixer, IF amplifier, detector, and a signal strength indicator amplifier) and one transistor amplifier to amplify the detected audio signals.

All components except Tuning capacitor and ferrite bar antenna are mounted on a printed circuit board P150.

The AM signals induced in a ferrite bar antenna are applied to the input of RF amplifier (pin ①) through a capacitor of C151 and amplified to the level required for overcoming the conversion noises, thus giving good S/N performance. The tuned circuits inserted in both output and input circuit of RF amplifier assure very high image and spurious rejection performance.

Thus amplified and selected AM signals are then applied to one input of Mixer section (pin ⑥) through a coupling capacitor C158. While the local oscillator voltage is injected to the other input of the section (pin ⑤) through a capacitor C157. Then both AM signals and oscillating

voltage are mixed and converted into 455KHz intermediate frequency. The resulting IF signal is applied to the first IF transformer L153 consisting of one ceramic filter and two tuned circuits.

The output of L153 is led to the IF amplifier's input (pin ⑦) through a coupling capacitor C169 and amplified to the sufficient level to drive the detector. The output of IF amplifier (pin ⑧) is led to the detector's input (pin ⑫) through IF filter L154. The detected audio signal derived from pin ⑪ is filtered and amplified and final audio output is obtained from the collector of H152 and applied to the TAPE MONITOR OUT jacks through the function switch.

The DC component of the detected IF signal is used as a AGC voltage to control emitter current of RF and IF amplifier through the resistor R154 and R155. A part of the DC component is also applied to the signal strength indication amplifier incorporated in the IC. The output appears at pin ⑭ and is level adjusted by R152, indicated on the signal strength meter M004.

2.1 Suggestions for AM Tuner trouble shooting

Check for broken AM bar antenna, next try to tune station by rotating fly-wheel tuning knob slowly and observe the AM signal strength meter whether it deflects or not. If the signal strength meter gives a deflection at several frequencies received, no failure may exist in the stages at least preceding final IF transformer L154. Next connect a oscilloscope to the test point ⑥ or J157 and check for audio signals with the tuning meter deflected. If the signal strength meter does not deflect, check the local oscillator circuit. Normal oscillating voltage at the hot end of the oscillator tuning capacitor is about 1.5 or 3 volts, varying with tuning capacitor position. When measuring oscillating voltage use a RF VTVM, no circuit tester gives correct indication. If the local oscillator voltage is normal, check all voltage distribution in the AM circuits by using a DC VTVM and compare the measured values with those given in the schematic diagram.

3. FM TUNER

3.1 RF and IF Circuit

The FM Tuner section of the Model 4300 is divided into five functional blocks: FM Front End, IF Amplifier, Detector, Muting Control and MPX Stereo Decoding Circuit.

FM signals induced by a FM antenna are led to FM antenna coil L101 through a Balun coil. These signals are then applied to the FET RF amplifier which in turn applies its output to the next FET Mixer H102 through the triple tuned high selective circuits. The FET Mixer converts its input signal into 10.7 MHz intermediate frequency and amplifies it at the same time. The H103 is a local oscillator and its output is injected into the source of the FET Mixer, the injection voltage is about 700mV. The 10.7 MHz front end output is led to the next IF amplifier unit through a coaxial cable.

The IF amplifier unit consists of seven stages of IF amplifier and one stage of AGC amplifier. Eight pieces of ceramic filters are also used to obtain high selectivity, four stages of symmetrical diode limiters are also employed for the best limiting characteristics, improved capture ratio and AM good suppression.

A part of FM Front End output is applied to the AGC amplifier H209 and rectified its output is fed back to the gate of FET RF amplifier to decrease the gain with increased signal strength.

The signals required for signal strength indication are obtained from the five stages of IF amplifiers through coupling capacitors C252, C211, C214, C223 and C228 respectively and rectified by three pair of full wave diode circuits. Thus obtained these DC components are appropriately mixed and applied to the signal strength meter through the Meter Amplifier H316.

The IF signal sufficiently amplified through each stage of IF amplifier is finally applied to the Detector Amplifier H208. The detected audio output is led to the buffer amplifier H210 and its buffered output is led to; (a) noise amplifier H310 through resistor R378 and capacitor C333, (b) QUADRADIAL OUTPUT Jack on the rear panel through resistor R379, (c) MPX stereo decoding IC (H321) through R301 and H301.

3.1 Audio Muting and Stereo Mode Auto-Selecting Circuit

The muting circuit consisting of all solid-state electrical switching has been incorporated in the Model 4300. Three inputs control the muting function. The first is related to signal strength, the second to the noise condition at the detector and the third is derived from the DC component of the detector output. These inputs are properly matrixed and gated to provide muting free from noise and transients.

The first input of DC voltage obtained by rectifying a part of IF output signal from the H205 and H206 is applied to the base of H308 and turns on it, if the IF output is greater than predetermined level (muting threshold level). When the H308 is turned on the H309 is turned off, allowing the emitter-collector resistance increasing and the collector voltage rises about 9V. The increased collector voltage increases the gate bias voltage and turns on the switching FET H301, decreasing the source-drain resistance to near zero ohm and allowing the audio signal applied to the source to flow to the pin ② of decoding IC through the source-drain path.

When the input signal is lower than predetermined level, the DC output obtained is small and can not turn on the H308, thus the H308 keeps its turn-off stage and this makes H309 turn on, decreasing the collector voltage and turning off H301. Thus no audio signals can pass through the FET. This is the fundamental principle of the muting operation but for more elaborate muting operation the second and the third inputs are necessary.

The second input is used to protect the muting operation and MPX stereo beacon lamps from misoperation due to undesirable noises. The high frequency noises included in the detected audio signals are separated by a small capacitor C333 and amplified by the noise amplifier transistor H310 and its output is rectified by the two diodes. The rectified DC output is proportional to the noise components in the audio signals.

When there are excessive noises in the audio signals such as obtained with a station incorrectly tuned in, the rectified DC output turns on the transistor H311, decreasing the emitter-collector resistance to zero. This means the collector of H309 is short-circuited to the ground, therefore the H301 is turned off and any audio signals having excessive high frequency noises can not go through the FET's source-drain path.

The transistor H317, also, turns off when transistor H309 or H311 turns on, and turns on the transistor H303 connected to pin ⑧ on the MPX decoding IC. Pin ⑧ is therefore grounded equivalently to set the IC in the monaural mode of operation. This prevent misoperation due to undesirable noises when the FM tuner is out of tuning.

The third input is obtained from the FM discriminator circuit. The DC output so called "S" curve is applied to the gate of H312 through a resistor R281 and dividing network (R361 & R362). The DC output is zero with a station correctly tuned in, but will vary from negative to positive values or vice versa when the tuning point is deviated toward either plus or minus frequency from the correct tuning frequency.

When the DC output is increased to a greater level than that of predetermined, the increased source potential of H312 makes the transistor H315 turn on (this means the collector of H309 is short-circuited to the ground), ... H301 turn off, ... H317 turn off, ... H303 turn on. This grounds pin ⑧ of the MPX stereo decoding IC, therefore the decoder is set in the monaural mode of operation and the stereo indicator lamp turns off. When the DC output is increased to the negative predetermined level, the decreased source potential turns off the H313 which in turn makes the H314 turn on (this means the collector of H309 is short-circuited to the ground). The subsequent changes are exactly the same as that just described above.

Thus when the tuning is shifted or deviated to the certain frequencies in which undesirable noisy side-audio signals are produced, both muting and monaural/stereo Switching Transistor H303 are operated automatically and open the circuits.

With the station correctly tuned in, the bias current of the FET H312 is adjusted so that both transistor H314 and H315 are not turned on, giving no effect on the transistor H309.

3.2 MPX Stereo Decoding Circuit

The stereo composite signal from the buffer amplifier undergoes a phase compensation by R301 and C301, is applied through the muting switching FET H301 to the input terminal pin ②, of the MPX stereo decoding IC H321 on a PLL (Phase Locked Loop) basis, and decoded into the left and right stereo signals, which become available at pins ④ and ⑤ respectively. These decoded left and right stereo audio signals are introduced through a low pass filter composed of L301 to L304 and C311 to C320 for elimination of undesirable residual switching signal and through a de-emphasis network consisting of R325, R326, C321 and C322, into the npn-pnp direct coupled audio amplifier, where the signals are amplified to a required level for the output from J311 and J313. From these jacks, the audio signals are led to the TAPE MONITOR OUT jacks through the function switch. Figure 1 presents an internal block diagram showing the functions of the PLL basis MPX stereo decoding IC HA1156. The input stereo composite signal, amplified by the audio amplifier, is delivered to the phase detectors PD-1 and PD-2. A part of the stereo composite signal is also applied to the stereo decoder section. The VCO (Voltage Control Oscillator) produces a free run oscillation in the neighborhood of 76KHz with the time constant determined by a capacitor C305 and resistors R311 and R312 set on the outside of pin ⑭. The VCO output has its frequency divided into 19KHz through the two stages of the frequency divider (DIV-1 & DIV-2), and is reverted to the phase detector PD-1, which contains two input terminals designed to produce an output in proportion to the product of the two input signals. The signal applied to one of the inputs of PD-1 is the 19KHz square wave formed through frequency division of the 76KHz VCO output signal by the two stages of the frequency divider DIV-1 and DIV-2, and the 19KHz pilot signal included in the stereo composite signal as a reference signal is applied to the other input. Therefore, the output of PD-1 which has passed through the low pass filter LPF-1 provides DC output voltage in proportion to the phase variance between the two inputs. This DC output voltage is amplified by the DC amplifier, and supplied to the 76KHz VCO as a control voltage. This means that the output frequency and phase of the VCO have been phase-locked to the input pilot signal. The 38KHz sub-carrier reproduced by PLL as stated above is delivered through the stereo switch to the stereo decoder section as a switching signal, thus driving the decoder section. One of the inputs of PD-2 is given the 19KHz resulting from the frequency division completed by DIV-1 and DIV-3, whereas the other input gets the 19KHz output contained in the composite signal, and the output is provided with a DC output in proportion to the amplitude of the pilot signal.

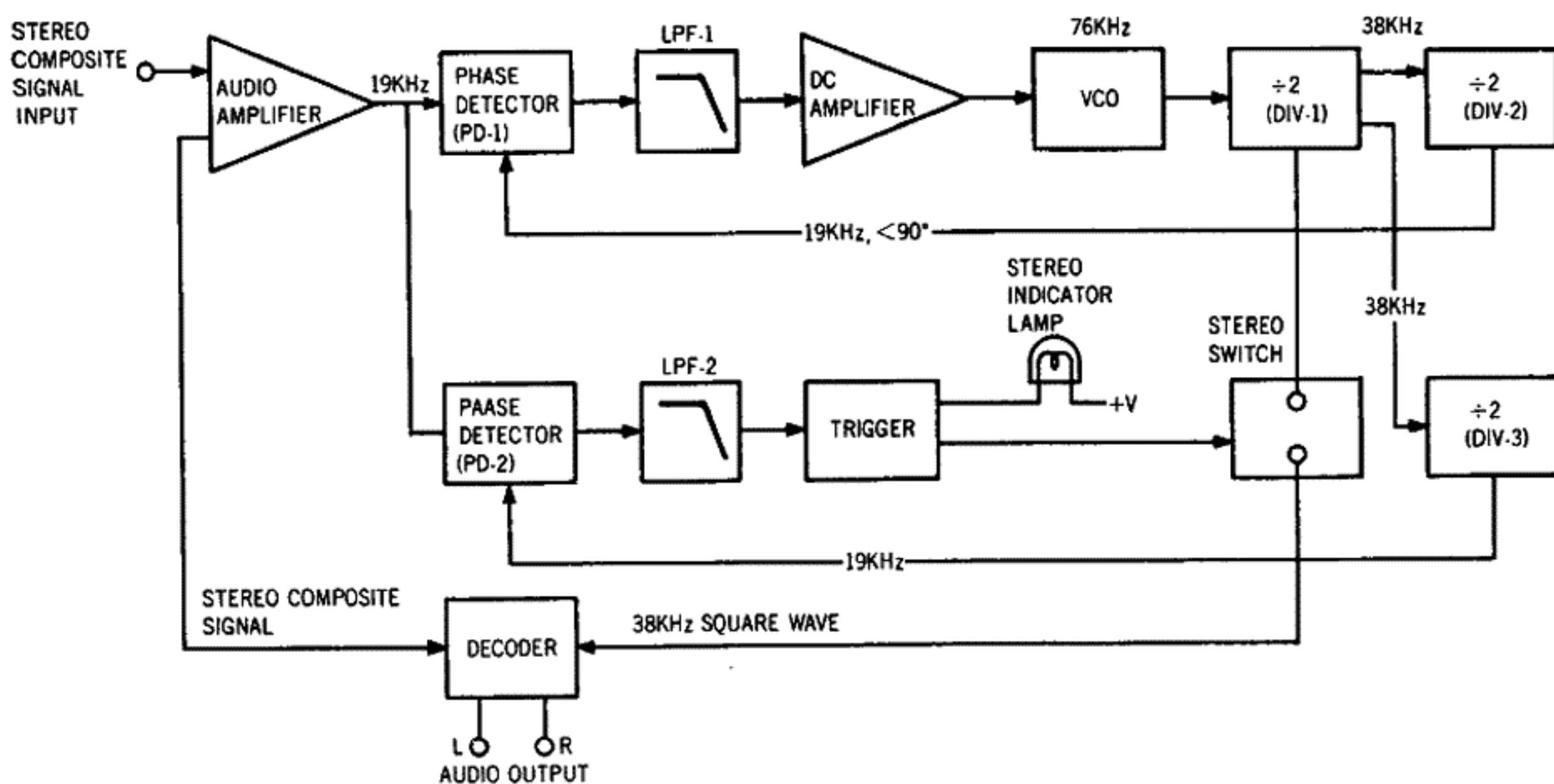

Figure 1. Block Diagram of the HA1156

This DC output is furnished through LPF-2 to the trigger amplifier which drives the stereo indicator lamp and stereo switch. Therefore, insufficient supply of the pilot signal results in failure to light the stereo indicator and to turn on the stereo switch located in the path of the 38KHz switching signal, thereby avoiding a wrong stereo operation. H303 attached on the outside of pin ⑧ is a switching transistor for automatic monaural-stereo switchover. When the intensity of an incoming signal from an FM station is weaker than a predetermined level, this H303 is turned on and pin ⑧ is grounded, thereby developing a condition for monaural reception. For a forced monaural operation, switch the MODE switch to "MONO," and H303 comes into an "On" condition with the positive bias voltage applied to the base, and pin ⑧ is grounded, thereby establishing monaural operation. The transistor H302 connected externally to pin ⑭ is intended to stop the 76KHz oscillation of the VCO which interferes an AM signal during the reception of an AM station. When the function switch is set to "AM" position, a positive bias is charged on the base of H302, H302 is turned on, and pin ⑭ is grounded. Thus, the oscillation of the VCO is stopped, ending the interference with AM reception.

3.3 Suggestion for Trouble Shooting of FM Tuner

3.3.1 Symptom: No FM Reception

First turn on the Power switch and try to tune FM stations. Rotate the fly-wheel tuning knob slowly and observe the FM signal strength meter. If the signal strength meter deflect at several frequencies received, the tuner circuits preceding the discriminator circuit may have no failure. When no reading is obtained in the meter, check FM local oscillator circuit, using a RF VTVM. The normal local oscillator voltage is one or two volts (rms) at the tuning capacitor, depending on the tuning capacitor position. If the local oscillator voltage is normal, next check all voltage distribution in the FM Front End and IF amplifier unit and compare them with those shown in the circuit diagram. When signal strength meter deflects but no sound is obtained, check audio circuit, using high sensitive oscilloscope.

3.3.2 Symptom: No Stereo Separation

First check the "MODE" switch is in normal 2 CH position. Connect a FM RF signal generator output modulated by a stereo modulator to the rear FM antenna terminals, and check the stereo beacon is turned on or not. If not turned on, check for 19KHz VCO output signal (J310), using an oscilloscope and a frequency counter.

4. PHONO AND PRE-AMPLIFIER

Signals from the PHONO jacks are applied to the phono-amplifier mounted on P400. The amplified and RIAA equalized phono signals and signals from the tuner section, CD-4/AUX and TAPE MONITOR IN jacks are applied to the SELECTOR switch which, in turn, leads the selected signals to the TAPE MON. switch and TAPE MONITOR OUT jacks. Applied to the other section of the TAPE MON. switch are signals from the TAPE MONITOR IN jacks. The TAPE MON. switch selects the signals from the SELECTOR switch or those from the TAPE MONITOR IN jacks and the selected signals go to the DOLBY and MODE switches. Signals are then mode processed by the MODE switch and its associated circuit and applied to the tone control amplifier through the buffer amplifier and BALANCE and VOLUME controls. The bass and treble controlled signals from the tone control amplifier pass through the hi filter before they reach the main amplifier.

4.1 Mode Switch

MODE switch S002 has positions of MONO, 2 CH, DISCRETE, VARI-MATRIX, and SQ DECODER.

In the MONO position, all input signals are mixed together and delivered to all four channels. In the 2 CH position, each pair of input signals right-front (RF) and right-rear (RR), and left-front (LF) and left-rear (LR) are mixed together. The resultant signals (RF + RR) and (LF + LR) are delivered to the pairs of RF and RR, and LF and LR channels, respectively.

In the DISCRETE position, each channel signal is separately routed to the corresponding channel.

In the VARI-MATRIX position, 2-channel stereo input signals are converted into quadraphonic signals through the vari-matrix circuit; the input right and left channel signals are fed directly to the LF and RF channels, while the signals to the LR and RR channels are synthesized from the 2-channel input signals under the control of the DIMENSION control. The LR and RR channel signal components are controlled by the DIMENSION control as shown below.

DIMENSION Control Setting	LR Output	RR Output
Minimum (FCCW)	LF + RF	RF + LF
Center	LF	RF
Maximum (FCW)	LF - RF	RF - LF

When the DIMENSION control is set to the minimum position the LR and RR channel signals become monophonic, to the center are stereophonic, and to the maximum are out of phase, thus providing vanished sound image positioning.

In the SQ DECODER position, signal sources encoded by the CBS SQ system are ideally decoded into 4-channel signals. Required for this operation is incorporation of the SQ Adaptor, Model SQA-1, into the Model 4300.

4.2 Balance Control

Signals from the buffer amplifiers are fed into the balance control circuit, in which the signals are controlled by three balancers: FRONT L-R, REAR L-R, and FRONT-REAR. By setting the FRONT-REAR balancer to the "FRONT" side and the FRONT L-R balancer to the "L" side, for example, only the front left channel is driven.

The balance control circuit is provided with the REMOTE CONTROL switch which makes the Model RC-4 Remote Control Box operative when set to the "REMOTE" position. In the "REMOTE" position the BALANCE and VOLUME controls on the Model 4300 become ineffective since signals are led to the Model RC-4. Balance and volume can be adjusted by the Model RC-4. Balance and Volume controlled signals are led to the tone control amplifier.

5. DOLBY UNIT

The Dolby units built in the Model 4300, which are two processors, allows you to monitor the Dolbyized recording sound with flat response from the loudspeakers during the Dolbyized recording on the tape recorder. The Dolby unit is inserted in front channels only.

An input signal coming to J601 (J602) is amplified by H601 (H602) and in the playback mode of operation, its output signal is led to the high-cut filter and is further amplified by H603 and H605. In the record mode of operation, the signal magnified by the H602 is directly amplified by H604 and H606. The signal magnified by H603 and H605 (H604 and H606) comes to the resistance mixing circuit of R623 and R625 (R624 and R626) and to the phase inverting circuit of H607 and H609 (H608 and H610). The output signal is fed out from J607 (J608) to the TAPE MONITOR OUT Jack or amplifiers.

Encoding and decoding in the Dolby circuit are accomplished as follows. In the record mode of operation, the signal from J606 is led to J612 and is discriminated in the frequency and level by the dynamic filter consisting of H612, resistor, and capacitor. The discriminated signal is then led to the amplifier of H614 and H616, and its output signal is fed back to the mixing circuit with in phase, thus increasing the output level at J608, i.e., "encoded". In the playback mode of operation, a part of the output signal (J607) is led to J611 and is discriminated in the frequency and level by the dynamic filter consisting of H611, resistor, and capacitor.

The discriminated signal is then led to the amplifier of H613 and H615, and its output signal is fed back to the mixing circuit with out of phase, thus decreasing the output level at J607, i.e., "decoded".

The diodes H626 to H629 function as a limiter. The attached "DOLBY PROCESSING CHART" will facilitate you to well understand the operation of the Dolby circuit.

6. 400Hz TONE

The 400Hz tone signal is a 580mV, 400Hz sine wave led to the FRONT and REAR TAPE MONITOR OUT jacks at any position of the DOLBY switch (with exception of the RECORD II position) and the SELECTOR switch.

The output signal of the 400Hz oscillator consisting of HL01 and HL02 is fed to JL02 and JL03, respectively, through the emitter follower HL03. The output levels at JL02 and JL03 are adjusted to 580mV and approximately 50mV, respectively.

The signal fed from the Dolby P.W. Board comes to JL04 and is rectified through HL06. The rectified output at JL06 is led to the meter M004.

7. DOLBY SWITCH

This switch sets the Dolby noise-reduction circuit for record or playback and also switches the Meter Mode from AM or FM SIGNAL STRENGTH to DOLBY CAL LEVEL, or vice-versa. With the DOLBY switch placed in "OFF" position, the Meter will be used as a SIGNAL-STRENGTH meter; in all other positions as a DOLBY CAL LEVEL meter.

7.1 Dolby FM

This position is used for listening to Dolbyized FM broadcasts. The Dolby FM level has been pre-adjusted by RC05 and RC06.

7.2 Play

This position is used to play back a Dolbyized source (except FM).

7.3 Off

With this position, the Dolby circuit is by-passed and the input signals are directly applied to both TAPE MONITOR OUT jacks and amplifiers.

7.4 Record I

For making a Dolbyized recording from an in-coming "flat" (non-Dolbyized) signal. When the MONITOR switch is in the SOURCE (out) position, the "flat" signal will be heard. When the MONITOR switch is in the TAPE (in) position, the "flat" signal will be heard after the Dolbyized signal from the tape has been decoded.

7.5 Record II

For making a "flat" (non-Dolbyized) recording from an in-coming Dolbyized signal. Regardless of the position of the MONITOR switch, a "flat" signal will be heard.

8. RECORD LEVEL (L) (R)

These knobs control the record level of the signals to be recorded through the Dolby unit. Adjust the knobs so that the Level Meter pointers of the tape recorder do not exceed the OVU level.

9. PLAY CAL. (L) (R)

These knobs adjust the playback outputs from a tape deck to the proper Dolby level.

10. DOLBY FM PRESET LEVEL CONTROLS

These factory-adjusted controls govern FM output level to the Dolby circuit. These controls are for the use of a qualified technician only.

11. 400Hz TONE SWITCH

This is used for calibration of the record input level of the tape deck. When the switch is depressed, the built-in oscillator operates and a sine wave signal output of 580mV will be applied to the four TAPE MONITOR OUT jacks.

12. FM DE-EMPHASIS SWITCH

At present both normal and Dolbyized FM broadcast programs are being transmitted with pre-emphasis time constant of 75 microsecond.

However if the Dolbyized FM broadcasting is approved by F.C.C., this pre-emphasis time constant for Dolbyized FM broadcast will be changed to 25 microsecond. The FM DE-EMPHASIS switch provided on the rear of Model 4300 is used for switching the time constants. After the permission of Dolbyized FM broadcasting, set the switch to 25 μ S position. This automatically change the time constant to 75 μ S while the DOLBY switch is placed in other than DOLBY FM positions (namely normal FM broadcast position), thus, the de-emphasis time constant for each normal and Dolbyized FM reception will be correctly set.

13. POWER AMPLIFIER

This power amplifier is a completely direct-coupled amplifying circuit. The transistor H701 and H702, which form the first stage of the differential amplifier, improve the DC stability. The transistor H705 is a current regulating circuit which further improves the DC stability. The transistor H707 and H708, which form the second stage of the differential amplifier, function as driver. The transistor H737 is a current regulating circuit as the load circuit H707. The transistors H713 and H714 drive the transistors H003 and H004 which form the power output stage. The transistor H711 is a transistor biasing circuit.

Excessive current flow in the power output stage is detected by the resistor R761 and the resultant variation is applied to the transistors H717, H719 and H721 and make them turned on. This decreases the base biasing current for H713 and H714. In this way the current flow in the power output stage (H003 and H004) is restricted within a safe predetermined value.

14. BTL (Balanced Transformer-less) CONNECTION

This power amplifier is designed to operate in either 2-channel or 4-channel modes, depending on the setting of the POWER MODE switch that incorporates phase-conversion and power switch for BTL connection.

With this switch placed in the 40Wx4 position, this unit operates as a 40W 4 channel amplifier. With the switch placed in the 100Wx2 position, the unit operate as a 100W 2 channel amplifier, in this case, the power output is obtained only from FRONT SPK terminals.

15. POWER SUPPLY UNIT

The power supply unit consisting of transistors H801, H802 and H803, which operates as an automatic voltage regulator provides +35V DC to all of the amplifiers except main amplifiers and +14V DC to the tuner section.

16. AUDIO TROUBLE ANALYSIS

1. Excessive line consumption
 - a. Check for shorted rectifiers H001 through H008.
 - b. Check for shorted transistors H713 through H716.
 - c. Check L003 for short.
2. No line consumption or zero bias
 - a. Check line cord, fuse, shorted H711 & H712, H727 & H728.

- 3. Excessive hum and noise level
 - b. Check for open rectifiers H810 & H811 or open L003.
 - a. Check filter capacitors C005, C006, C709, C710, C713, C714, C715 & C716.
- 4. Parastic oscillation
 - b. Check for shorted transistor H801 and H802.
 - a. Check for defective capacitors, C005, C006, C705, C706, C707, C708, C717, C718, C719, C720, C721, C722, C723 & C724.
- 5. Improper clipping
 - a. Check for proper adjustment of R721 and R722.

17. TEST EQUIPMENT REQUIRED FOR SERVICING

Table 1 lists the test equipment required for servicing the Model 4300 Receiver.

Item	Manufacturer and Model No.	Use
AM Signal Generator		Signal source for AM alignment.
Test Loop		Used with AM Signal generator.
FM Signal Generator	Less than 0.3% distortion	Signal source for FM alignment.
Stereo Modulator	Less than 0.3% distortion	Stereo separation alignment and trouble shooting.
Frequency Counter		MPX Oscillator adjustment (VCO).
Audio Oscillator	Weston Model CVO-100P, less than 0.02% residual distortion is required.	Sinewave and squarewave signal source.
Oscilloscope	High sensitivity with DC horizontal and vertical amplifiers.	Waveform analysis and trouble shooting and ASO alignment.
VTVM	With AC, DC, RF range	Voltage measurements.
Circuit Tester		Trouble shooting.
AC Wattmeter	Simpson, Model 380	Monitors primary power to Amplifier.
AC Ammeter	Commercial Grade (1-10A)	Monitors amplifier output under short circuit condition.
Line Voltmeter	Commercial Grade (0-150V AC)	Monitors potential of primary power to amplifier.
Variable Autotransformer (0-140V AC, 10 amps)	Powerstat, Model 116B	Adjusts level of primary power to amplifier.
Shorting Plug	Use phono plug with 600 ohm across center pin and shell.	Shorts amplifier input to eliminate noise pickup.
Output Load (8 ohms, $\pm 1\%$ 100W)	Commercial Grade	Provides 8-ohm load for amplifier output termination.
Output Load (4 ohms, $\pm 1\%$ 100W)	Commercial Grade	Provides 4-ohm load for amplifier output termination.

Table 1. Test Equipment Required for Servicing

18. AM ALIGNMENT PROCEDURE

18.1 AM IF Alignment

1. Connect a sweep generator to the J153 and an alignment scope to the test point ⑥.
2. Rotate each core of IF transformer L153 and L154 for maximum height and flat top symmetrical response.

18.2 AM Frequency Range and Tracking Alignment

1. Set AM signal generator to 525KHz. Turn the tuning capacitor fully closed (place the tuning pointer at the low end.) and adjust the oscillator coil L152 for maximum audio output.
2. Set the signal generator to 1650KHz. Place the tuning pointer in the high frequency end and adjust the oscillator trimmer on the oscillator tuning capacitor for maximum audio output.
3. Repeat the step 1 and 2 until no further adjustment is necessary.
4. Set the generator to 600KHz and tune the receiver to the same frequency and adjust a slug core of AM ferrite rod antenna and RF coil L151 for maximum output.
5. Set the generator to 1400KHz and tune the receiver to the same frequency and adjust both trimming capacitors of antenna and RF tuned circuit for maximum output.
6. Repeat the step 4 and 5 until no further adjustment is necessary.

Note: During tracking alignment reduce the signal generator output as necessary to avoid AGC action.

18.3 AM Signal Strength Meter Adjustment

Set the AM Signal generator to 1000KHz with 74dB/m, and adjust R152 so that the signal strength meter may read 80%.

19. FM ALIGNMENT PROCEDURE

1. Connect an FM signal generator to the FM ANTENNA terminals and an oscilloscope and an audio distortion analyzer to the TAPE MONITOR OUT jacks on the rear panel.
2. Set the FM SG to 87.5MHz and provide about 3 to 5 μ V. Place the tuning pointer at the low frequency end by rotating the tuning knob and adjust the core of oscillator coil L105 to obtain maximum audio output.
3. Set the FM SG to 108.5MHz and provide about 3 to 5 μ V output. Rotate the tuning knob and place the tuning pointer at the high frequency end and adjust the trimming capacitor C106 for maximum output.
4. Repeat the step 2 and 3 until no further adjustment is necessary.
5. Set the FM SG to 90MHz and tune the receiver to the same frequency. Decrease signal generator output until the audio output level decreases with the decreasing generator output. Adjust the antenna coil L101, RF coil L102, L103 and L104 and IF transformer L106 for minimum audio distortion.
6. Set the FM SG to 106 MHz and tune the receiver to the same frequency. Adjust the trimming capacitors of antenna and RF tuning circuits for minimum distortion (C102, C103, C104, C105).
7. Repeat the step 5 and 6 until no further adjustment is necessary.
8. Adjust the secondary core (upper) of discriminator transformer L201 so that the center tuning meter pointer indicates its center at no signal applied. Set the FM SG to 98MHz and increase its output level to 1K μ V and tune the receiver to the same frequency so that the center tuning meter pointer indicates its center. Adjust the primary core (lower) of L201 for minimum distortion.
9. Set the FM SG to 98MHz with 100K μ V, and adjust R374 so that signal strength meter may read 90%.

19.1 Stereo Separation Alignment

1. Set the FM SG to provide 1K μ V at 98MHz. Tune the receiver to the same frequency so that

the center tuning meter pointer indicates its center. Then turn off the modulation of the FM SG, connect a frequency counter to test point J310 (point ©) and adjust R311 so that the frequency counter may a precisely read 19KHz.

2. Modulate the FM SG with stereo composite signal consisting of only L or R channel (of course a pilot signal must be included).
3. Adjust the trimming resistor R301 for maximum and same separation in both channels.

19.2 Muting Circuit Alignment

1. Connect a VTVM to the tap of the resistor R363 and adjust the resistor R363 until the meter reads 0.75V DC at no signal.
2. Set the FM SG to provide $1\text{K}\mu\text{V}$ at 98MHz and tune the receiver to the same frequency correctly.
3. Turn on MUTING push-switch. Shift the FM signal generator frequency to plus and minus and note both plus and minus shifted frequencies at which undesirable audio side responses are muted out. Adjust the R363 so that the same shifted frequencies mute the undesirable side response.
4. Adjust R362 for preferred frequency shift at which the muting circuit operates.

20. AUDIO ADJUSTMENT

1. Connect a VTVM to No. 11 of J036(+) and No. 9 of J036(-) and adjust the trimming resistor R739 until the VTVM reads 12mV DC. For the other channel connect the VTVM to No. 33 of J036(+) and No. 35 of J036(-) and adjust the R740 for the same reading.
2. Connect a VTVM to No. 13 of J036(+) and No. 15 of J036(-) and adjust the trimming

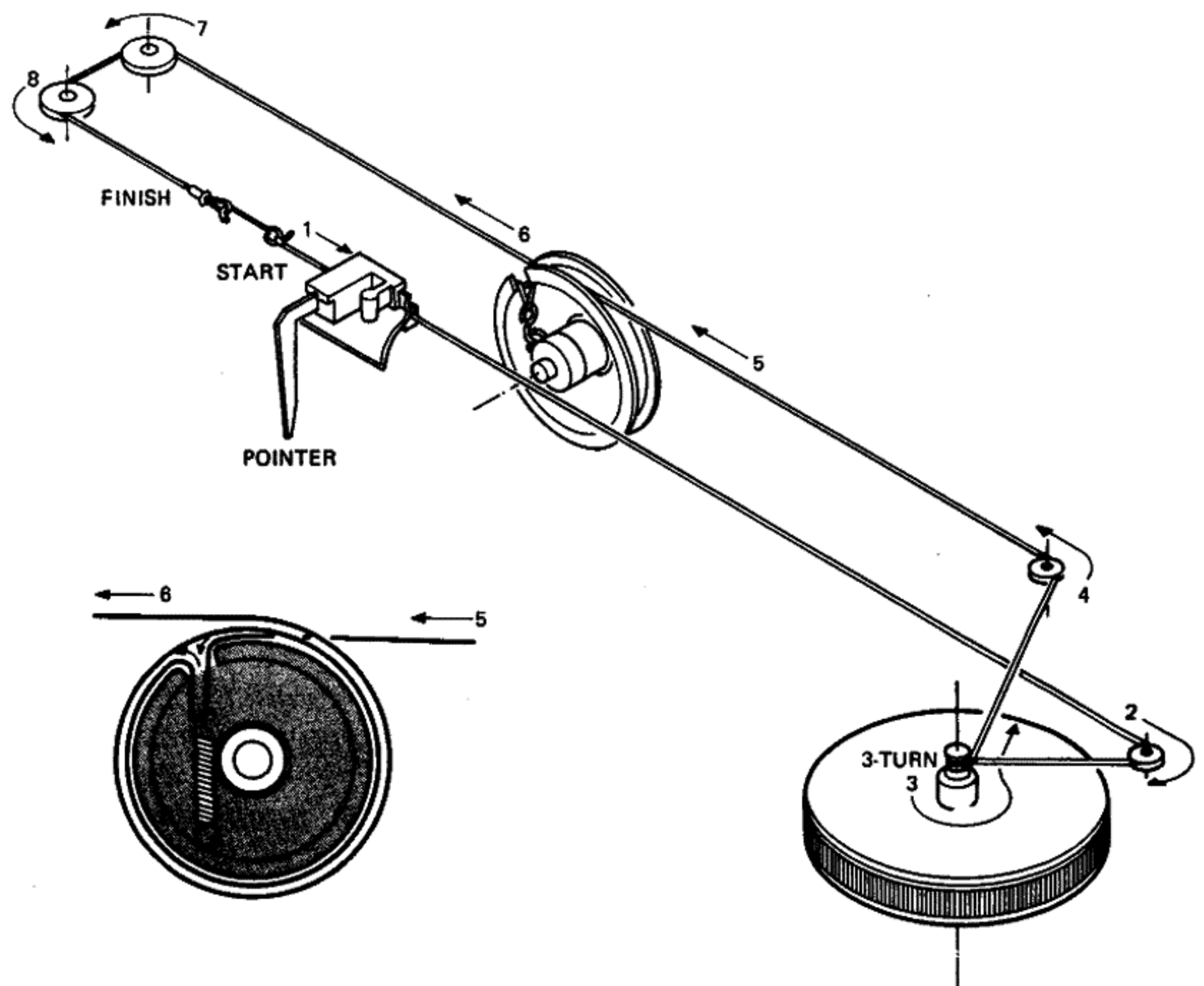

Figure 2. Dial Stringing

resistor R721 until the VTVM reads 0V DC. For the other channel connect the VTVM to No. 31 of J036(+) and No. 29 of J036(-) and adjust the R722 until the VTVM reads 0V DC.

21. AUTOMATIC VOLTAGE REGULATOR ADJUSTMENT

Connect a VTVM to JM03(+) and JM04(-) and adjust R806 until the VTVM reads 35V under no signal condition.

22. DOLBY ALIGNMENT PROCEDURES

For adjustment of the Dolby unit, an adjusting implement should be built up base on the attached circuit diagram. Then, using the adjusting implement proceed as follows.

1. A) Set the REC/PB switch to REC, the DOLBY ON/OFF switch to OFF (close), and the FET GATE switch to OFF (close).
 - B) Adjust the semi-fixed resistor R654 until the source voltage for the FET (H612) becomes maximum (positive).
 - C) Feed in 5KHz at a level to give 17.5mV at J606.
 - D) Note signal level obtained at the OUTPUT terminal.
 - E) Set the DOLBY ON/OFF switch to ON (OPEN) and adjust gain control (R660) for a 10 ± 0.25 dB rise at the OUTPUT terminal.
 - F) Note level at OUTPUT terminal with DOLBY ON/OFF switch ON.
 - G) Set the FET GATE to ON and adjust low control (R654) for a 2 ± 0.25 dB drop at OUTPUT terminal.
 - H) Check the level setting at Step C) to G)
2. A) Set the REC/PB switch to PB, the DOLBY ON/OFF switch to OFF (close), and the FET GATE switch to OFF (close).
 - B) Adjust the semi-fixed resistor R653 until the source voltage for the FET (H611) becomes maximum (positive).
 - C) Feed in 5KHz at a level to give 44mV at J603.

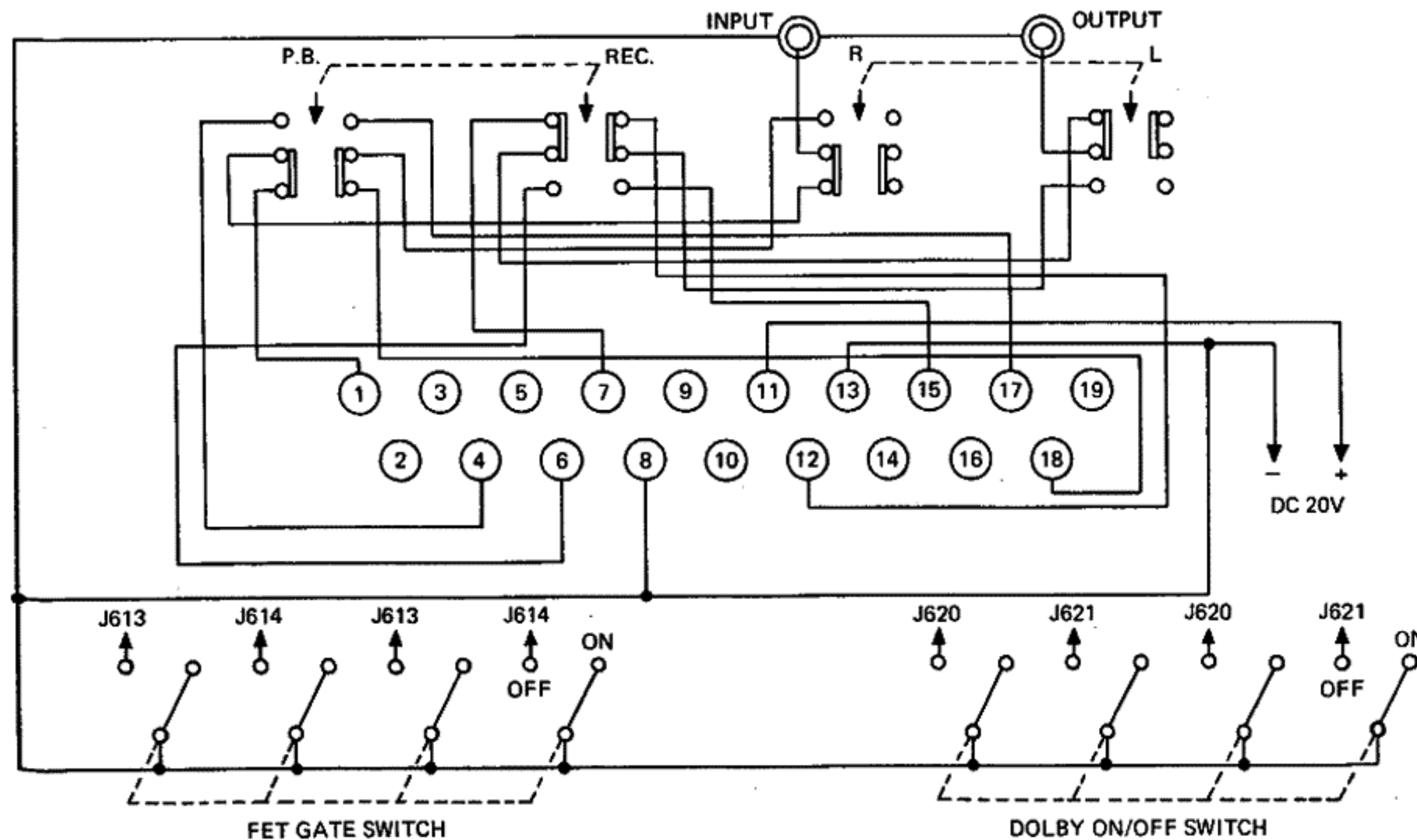

Figure 3. Dolby Alignment Implement Simplified Schematic

- D) Note signal level obtained at the OUTPUT terminal.
 E) Set the DOLBY ON/OFF switch to ON and adjust gain control (R659) for a 10 ± 0.25 dB fall at the OUTPUT terminal.
 F) Note level at OUTPUT terminal with DOLBY ON/OFF switch ON.
 G) Set the FET GATE to ON and adjust low control (R653) to give a rise of 2 ± 0.25 dB at the OUTPUT terminal.
 H) Check the level setting at Step C) to G).
3. For the level adjustment, set the DOLBY switch and SELECTOR switch to the RECORD I and CD-4/AUX positions, respectively, and use the TAPE MONITOR OUT jack for the output signal. By setting the 400Hz TONE pushswitch "in", the 400Hz sine wave is fed out. Adjust the semi-fixed resistor RL11 for 580mV of the sine wave output voltage in both R and L channels. Then, set the DOLBY switch to the RECORD II position, and apply the 400Hz signal for 580mV of the output voltage. Adjust the semi-fixed resistors RL28 and RL29 so that the DOLBY LEVEL meter may point the Dolby level. Change over the METER switch, and perform this adjustment for both R and L channels. Next adjust the semi-fixed resistor RL12 for 580mV output level when the DOLBY switch is set to the OFF position. Check this output level after the adjustment of the level setting semi-fixed resistors RL11 and RL12. The output level must be precisely 580mV since it is a reference voltage level in the Dolby circuit.

23. ALIGNMENT PROCEDURES OF DOLBY FM RESET LEVEL CONTROLS

Connect an FM signal generator to the FM antenna. Set the modulation frequency and degree of modulation of the FM signal generator to 400Hz and 50%.

Set the FM signal generator to 98MHz and the DOLBY switch to the OFF position. Turn the Tuning knob on Model 4300 until it tunes to the 98MHz signal from the FM signal generator.

Then, set the DOLBY switch to the DOLBY FM position, and adjust the FM preset level controls RC05 and RC06 so that the DOLBY LEVEL meter may point the Dolby FM level. Change over the METER switch, and perform this adjustment for both R and L channels.

24. EXPLANATION OF THE DOLBY PROCESSING CHART

This chart shows the condition of the signals available at the speakers (SPKRS) and at the TAPE MONITOR OUT terminals as a function of different control settings.

To understand the chart refer to the symbols below:

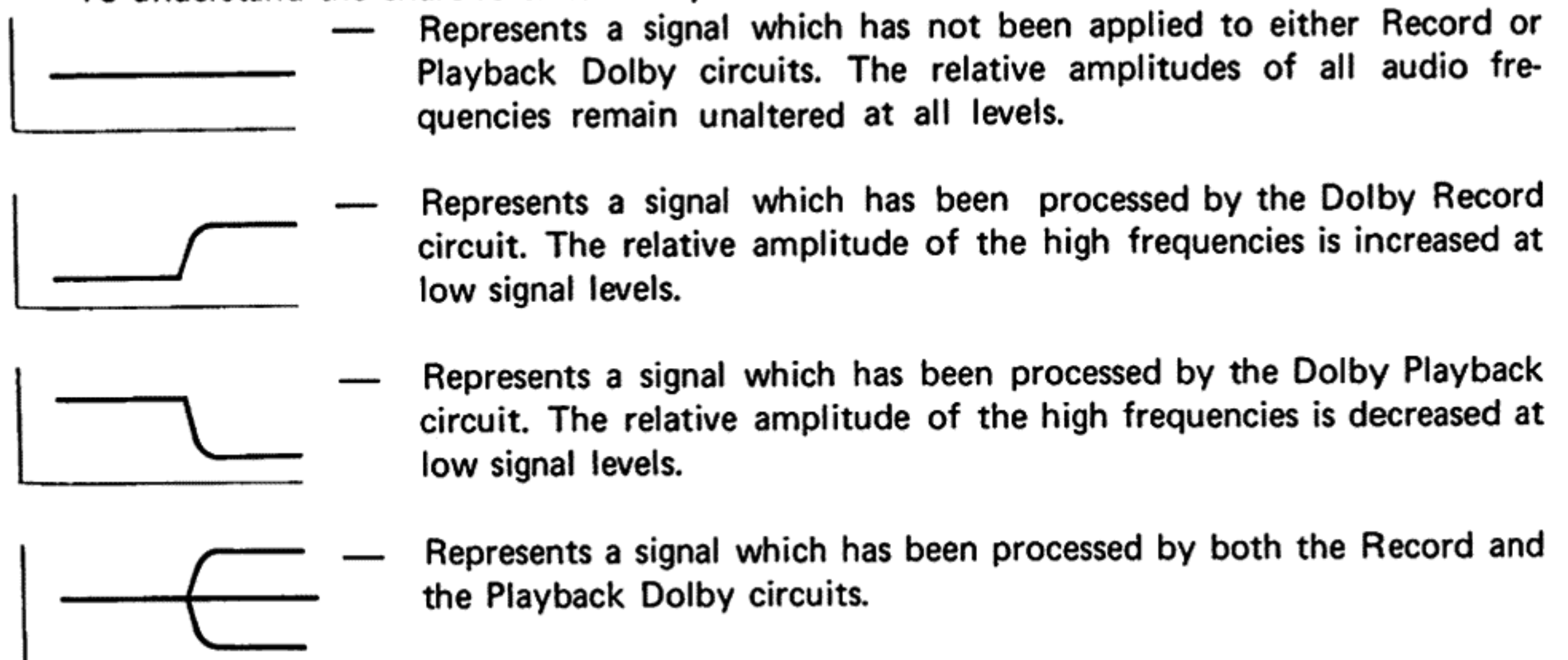

These circuits are complementary. Therefore, relative amplitudes of all audio frequencies are restored to their original values.

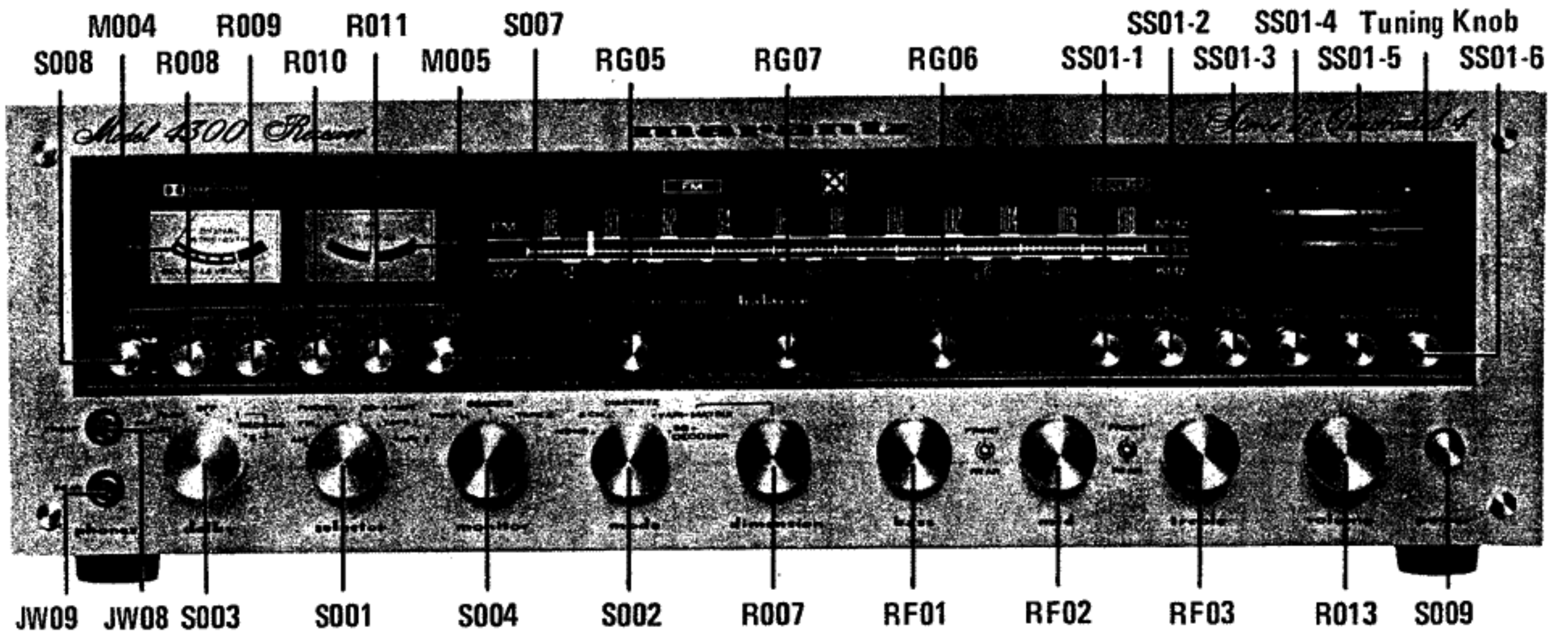

Figure 4. Front Panel Adjustment and Component Locations

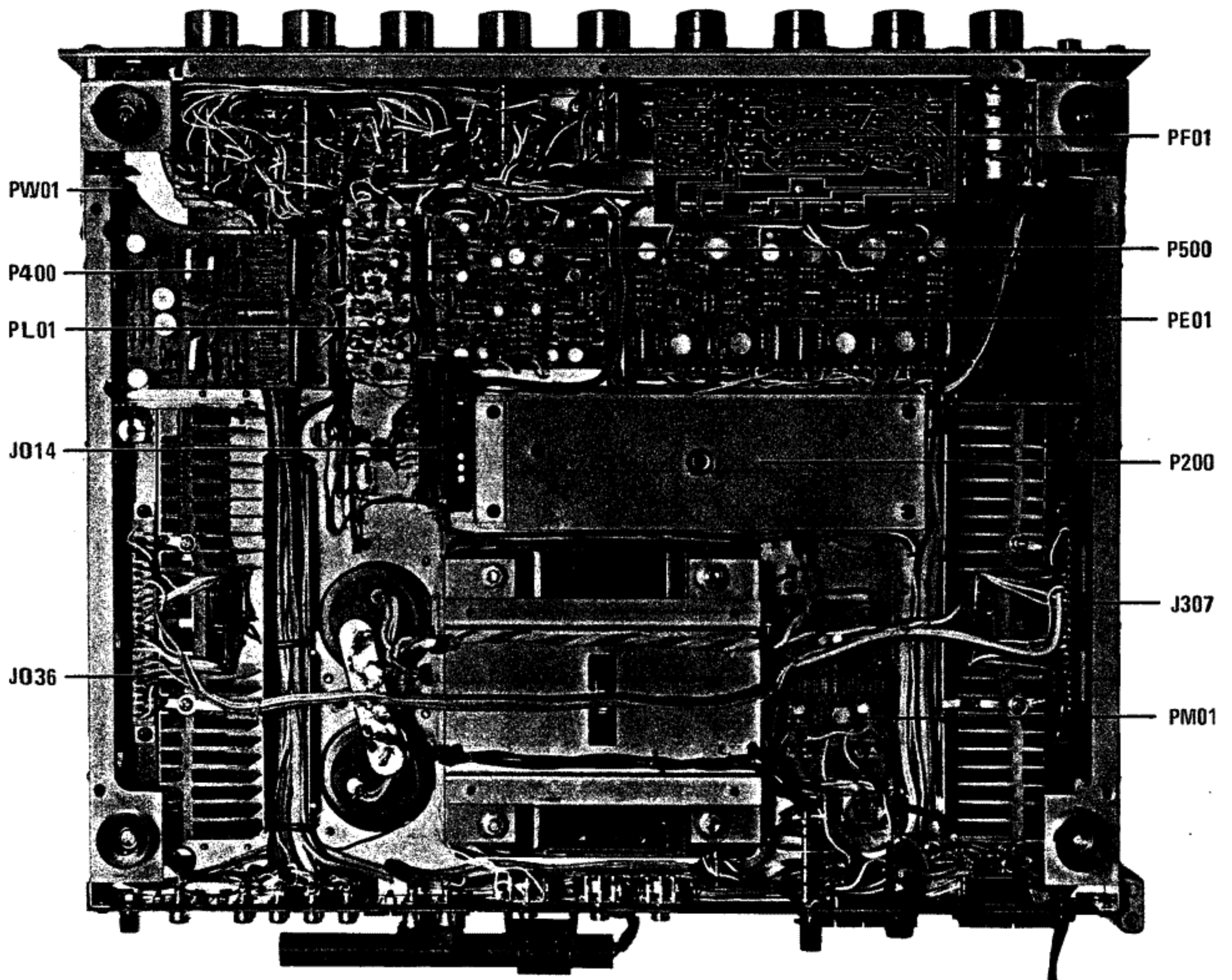

Figure 5. Main Chassis Component Locations (Bottom View)

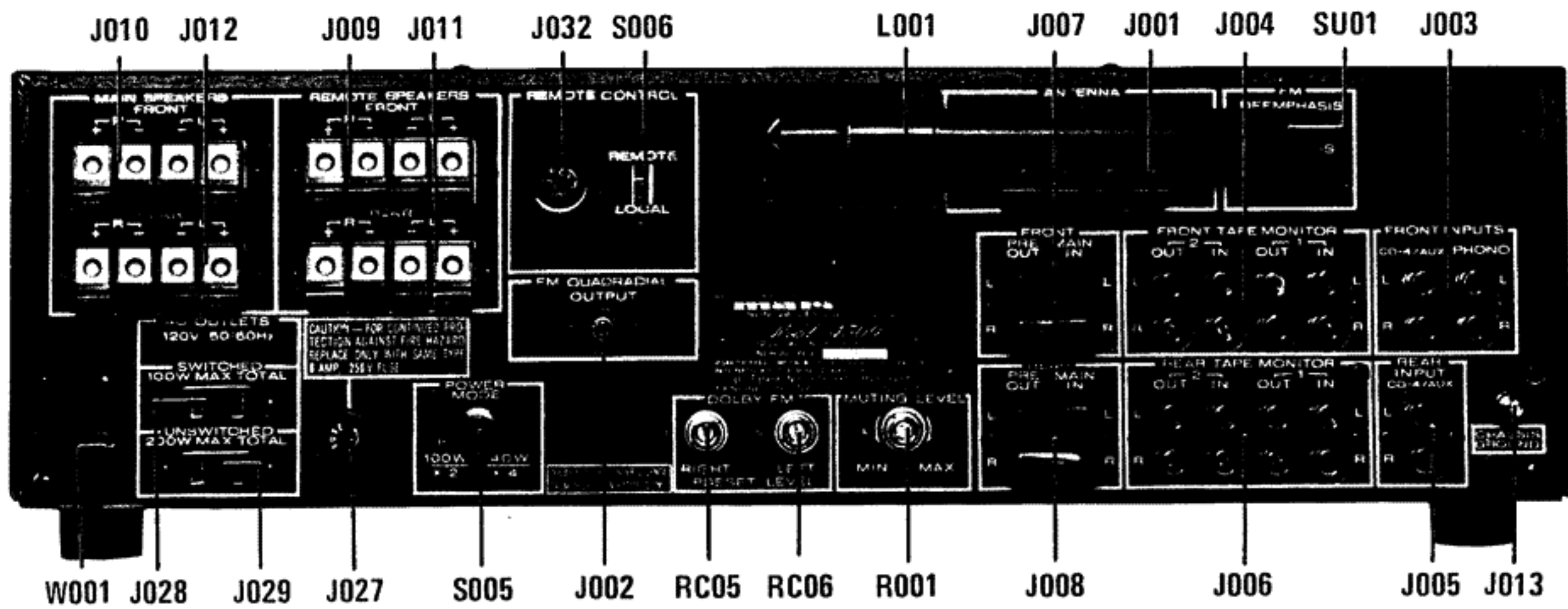

Figure 6. Rear Panel Adjustment and Component Locations

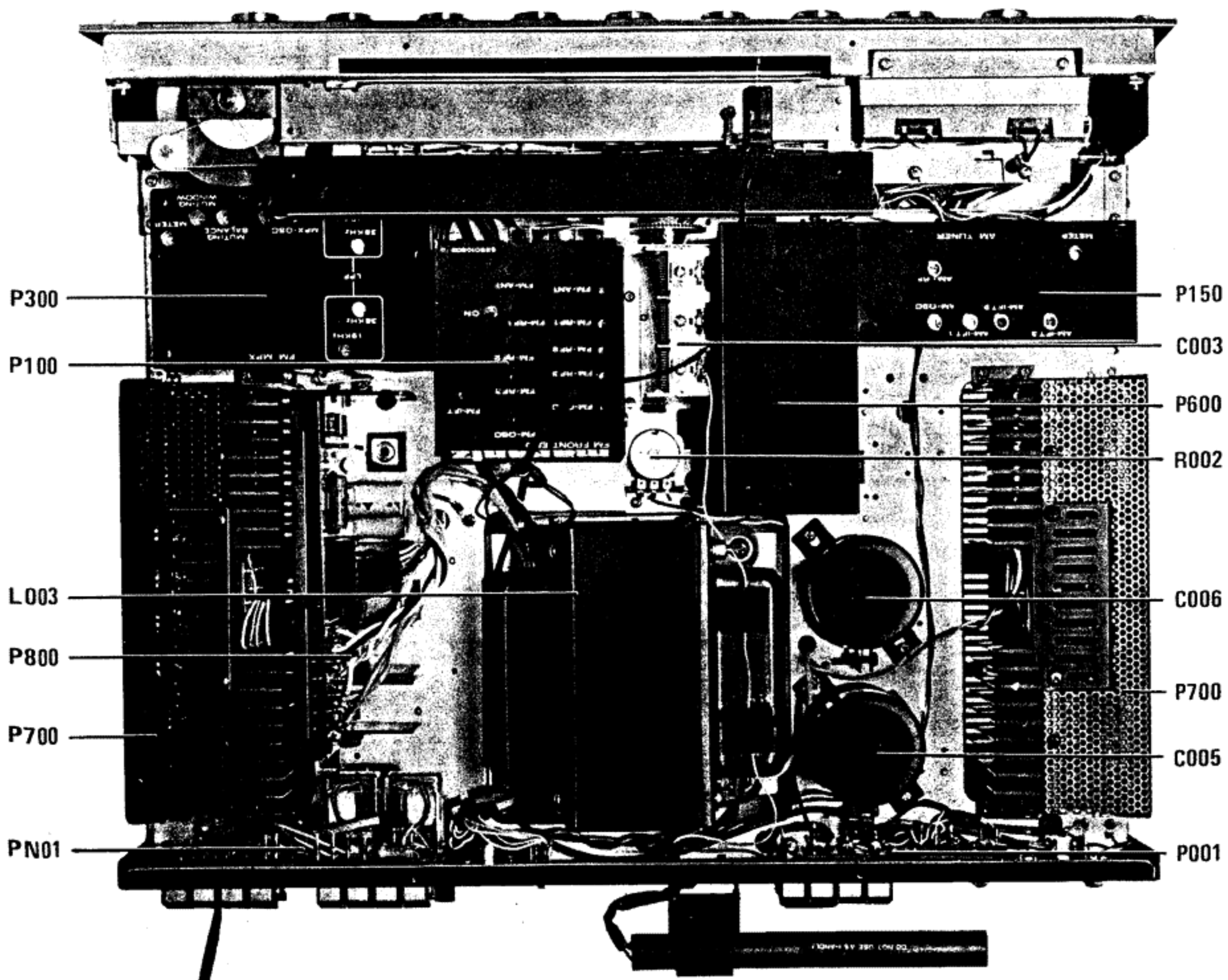

Figure 7. Main Chassis Component Locations (Top View)

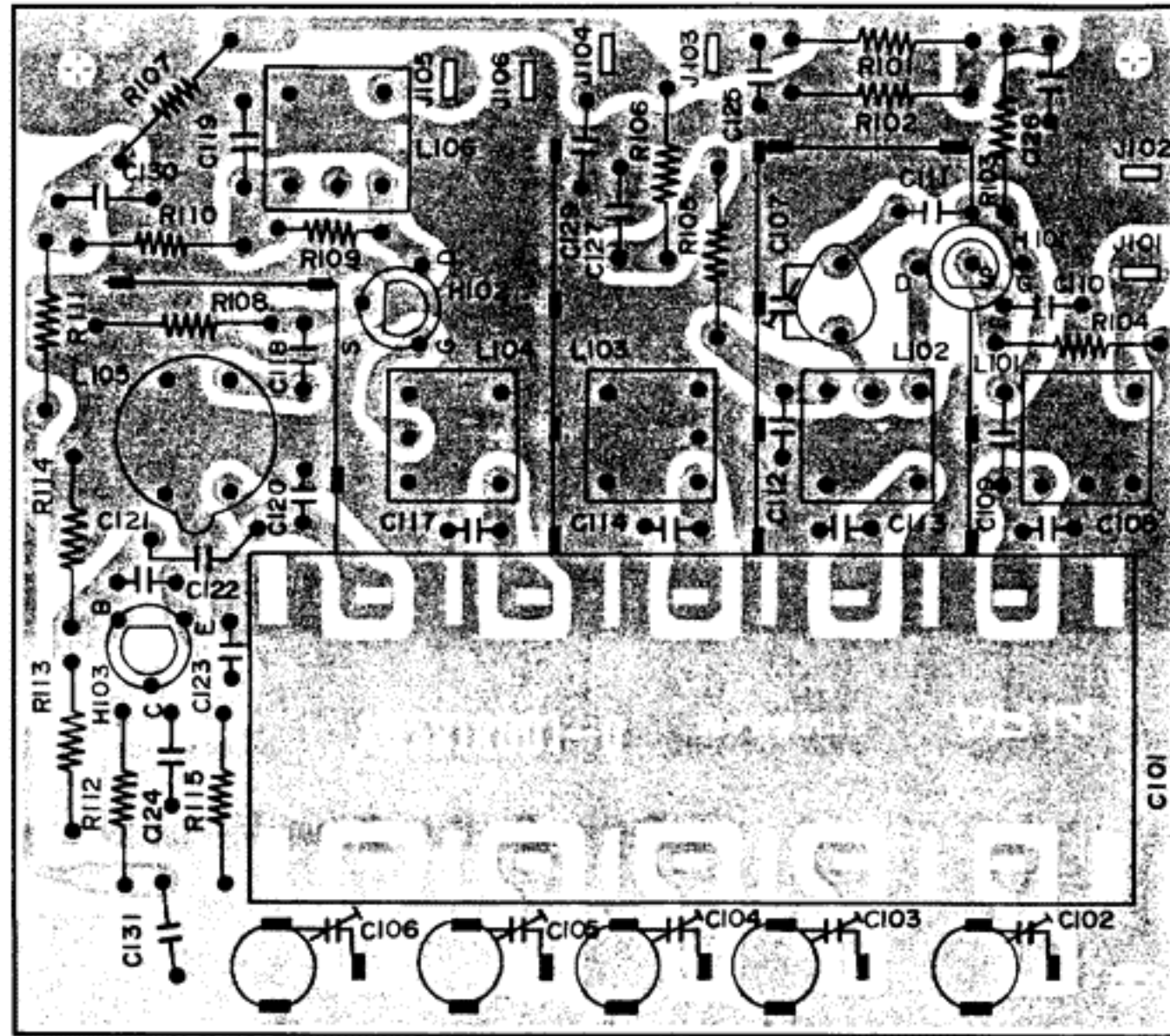

Figure 8. FM Front End Assembly P100 Component Locations

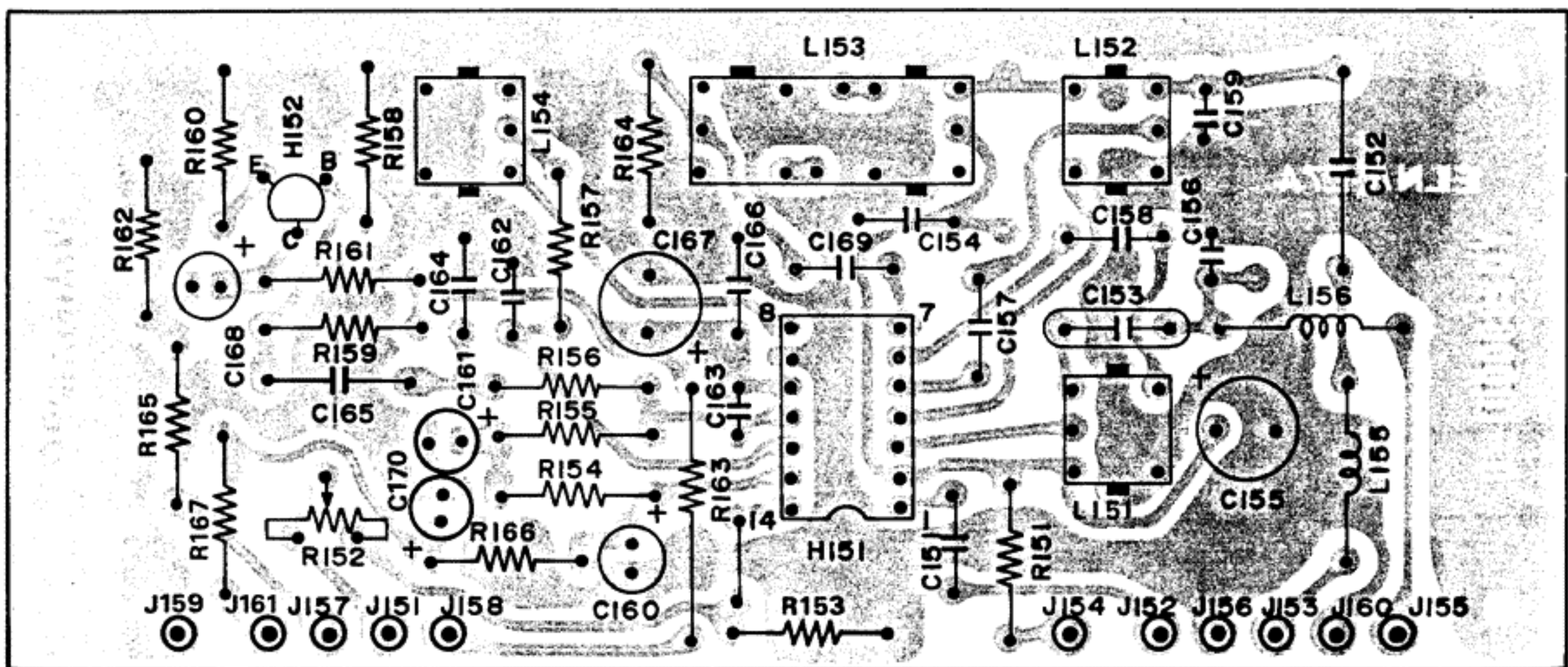

Figure 9. AM Tuner Assembly P150 Component Locations

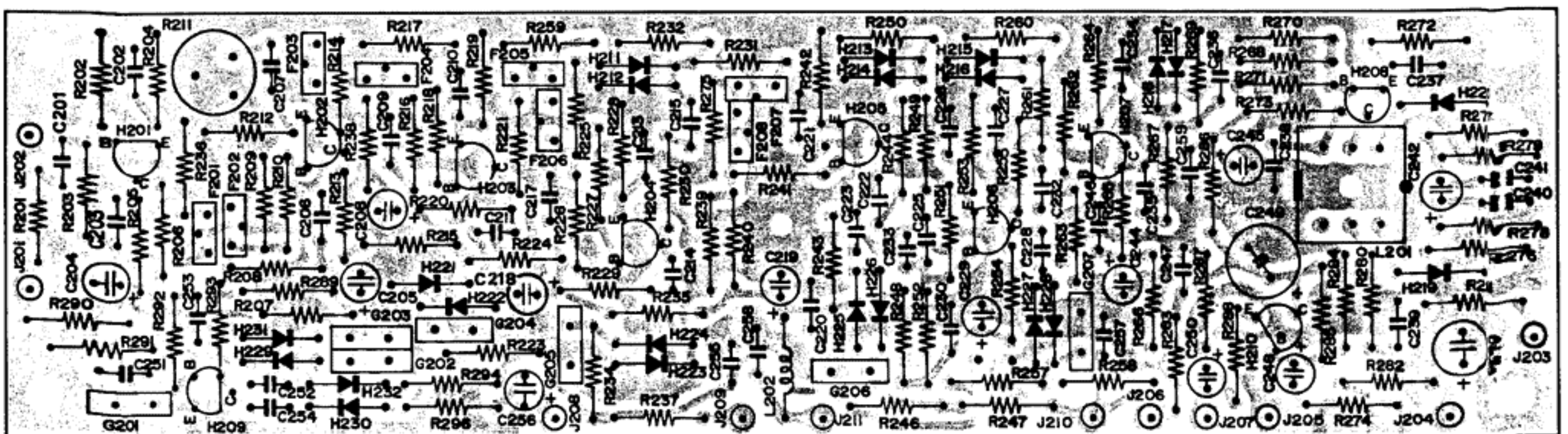

Figure 10. FM IF Amplifier Assembly P200 Component Locations

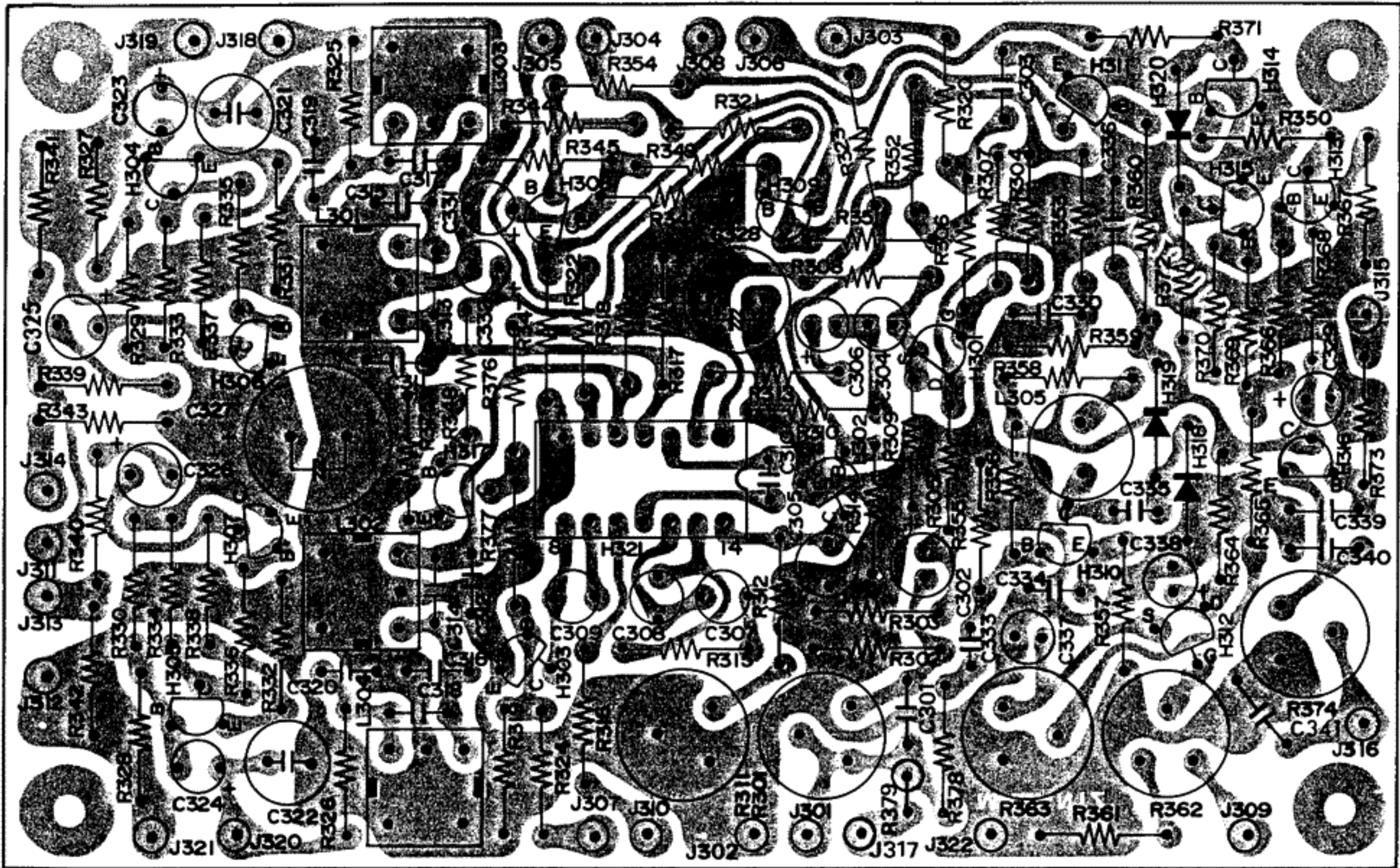

Figure 11. MPX Stereo Decoder, Noise and DC Amplifier Assembly P300 Component Locations

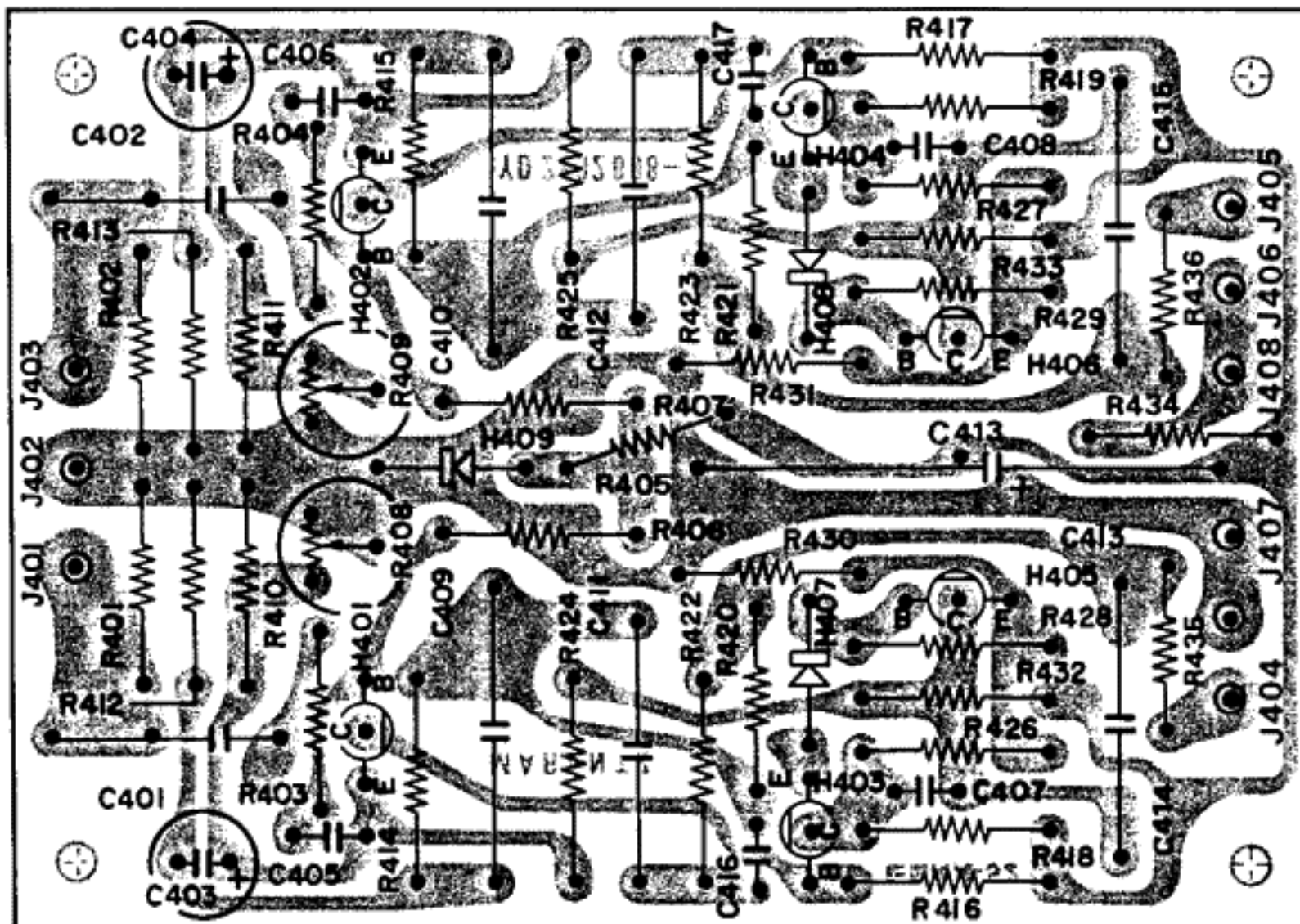

Figure 12. Phono Amplifier Assembly P400 Component Locations

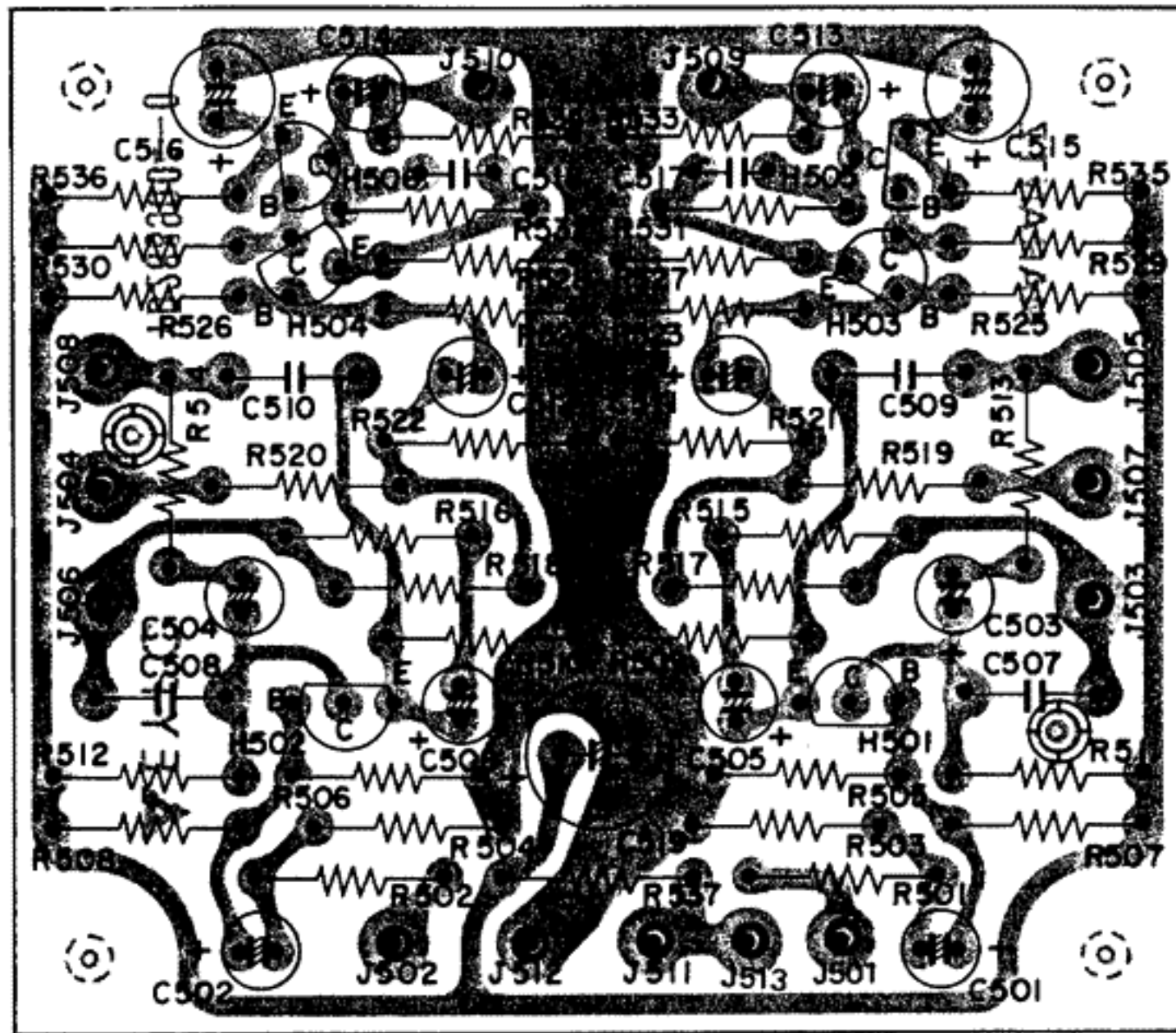

Figure 13. Vari-Matrix Assembly P500 Component Locations

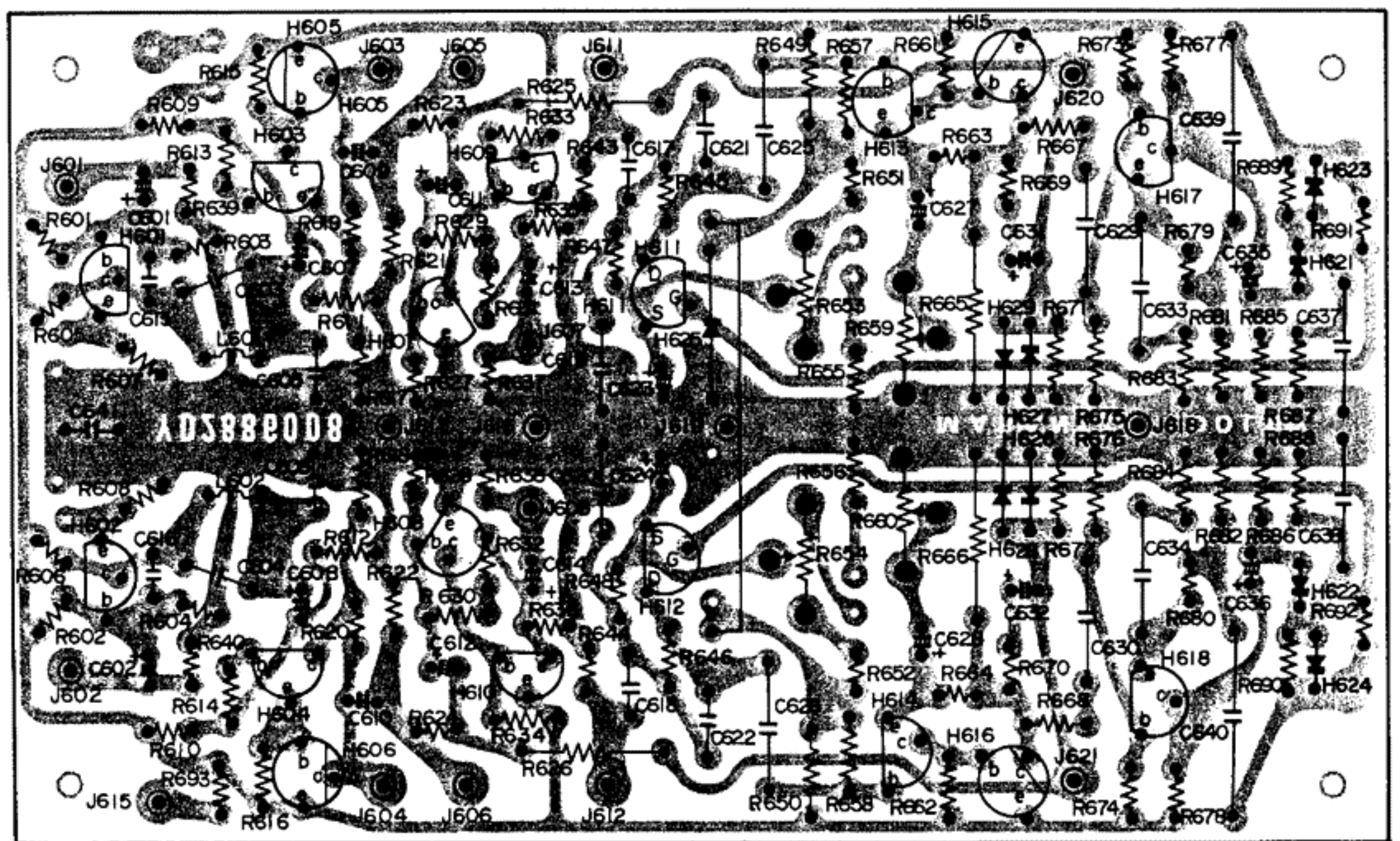

Figure 14. Dolby Unit Assembly P600 Component Locations

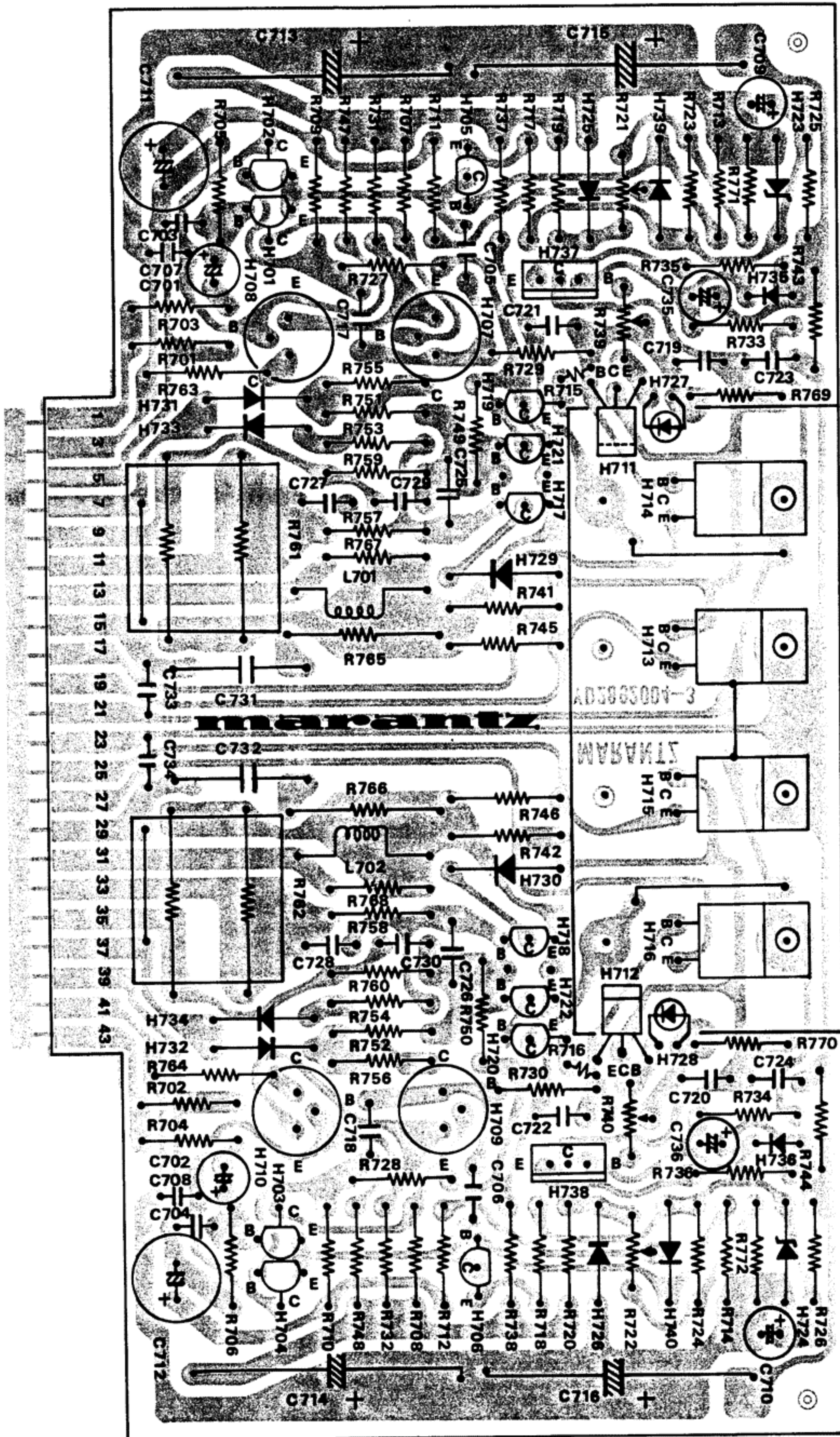

Figure 15. Power Amplifier Assembly P700 Component Locations

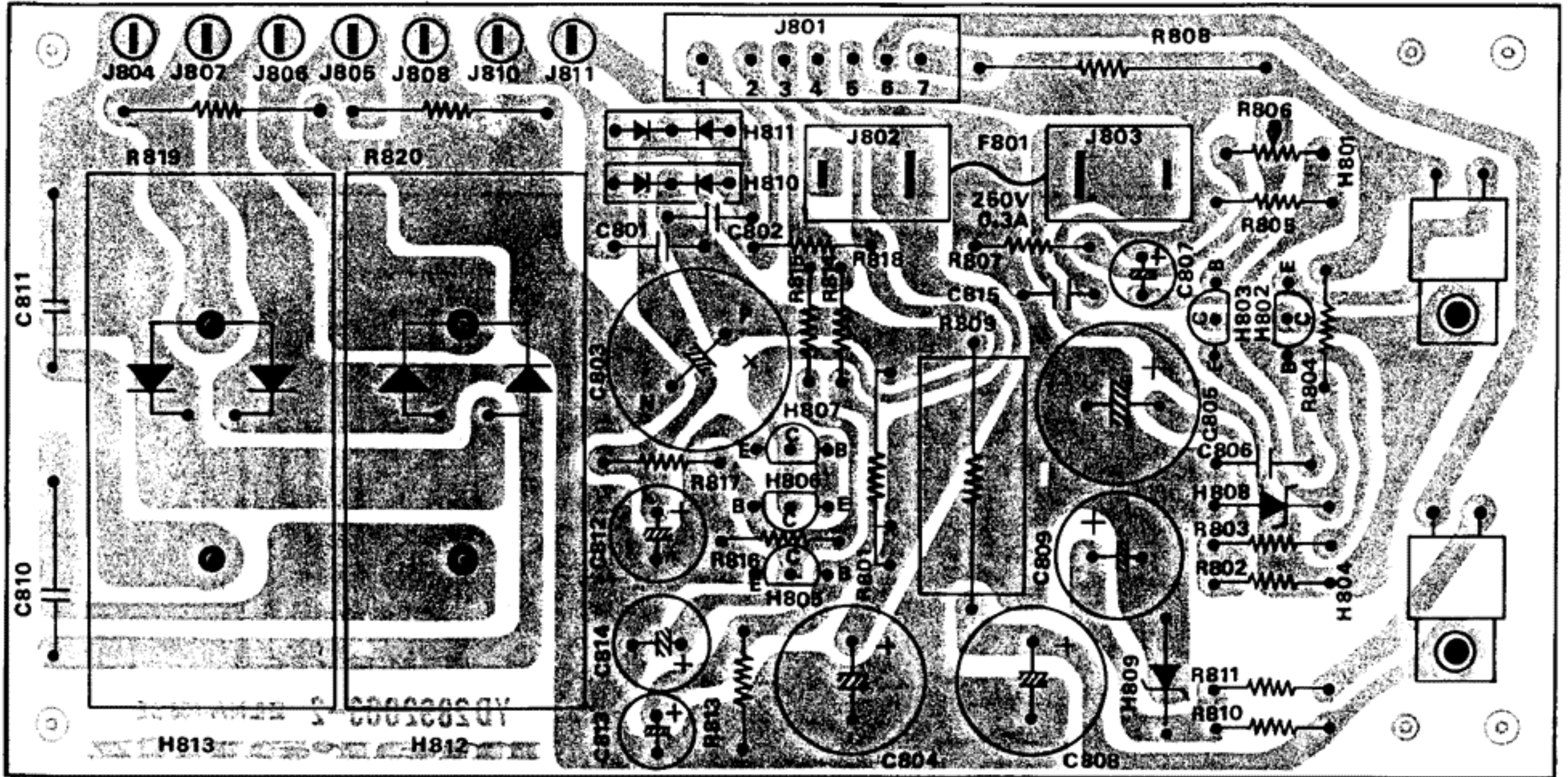

Figure 16. Power Supply Assembly P800 Component Locations

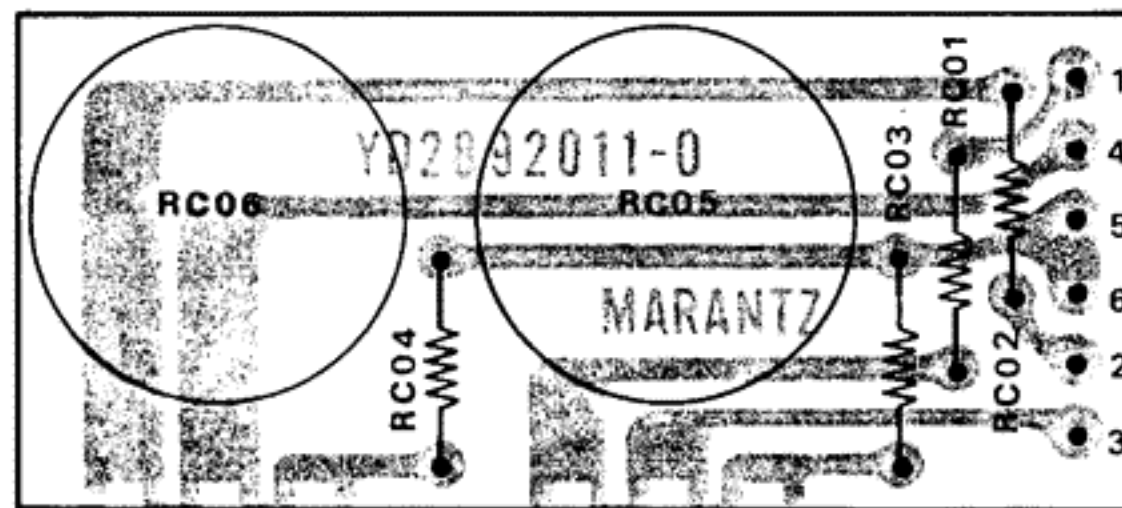

Figure 17. FM Cal. Assembly PC01 Component Locations

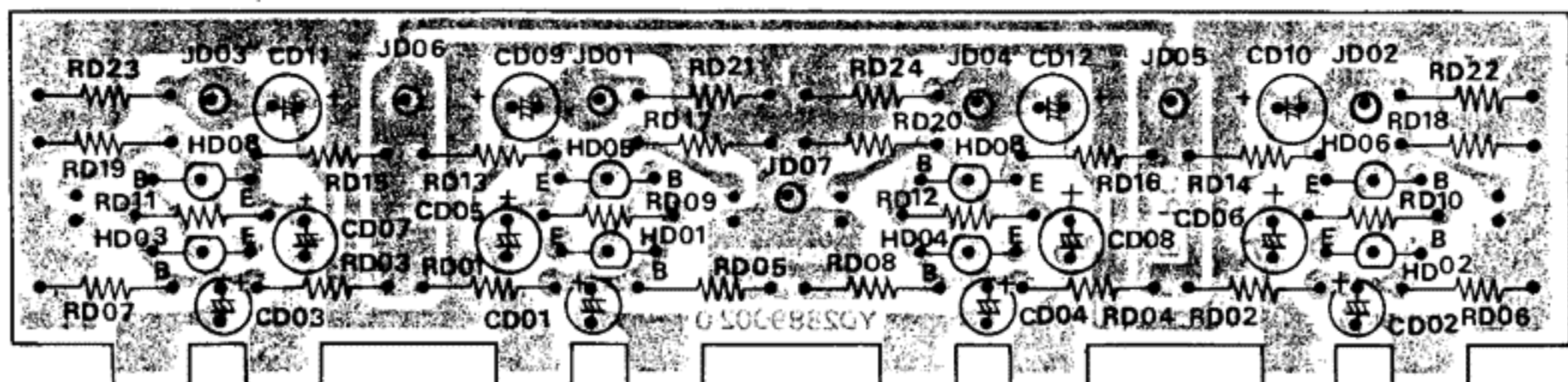

Figure 18. Tone Amplifier Assembly PD01 Component Locations

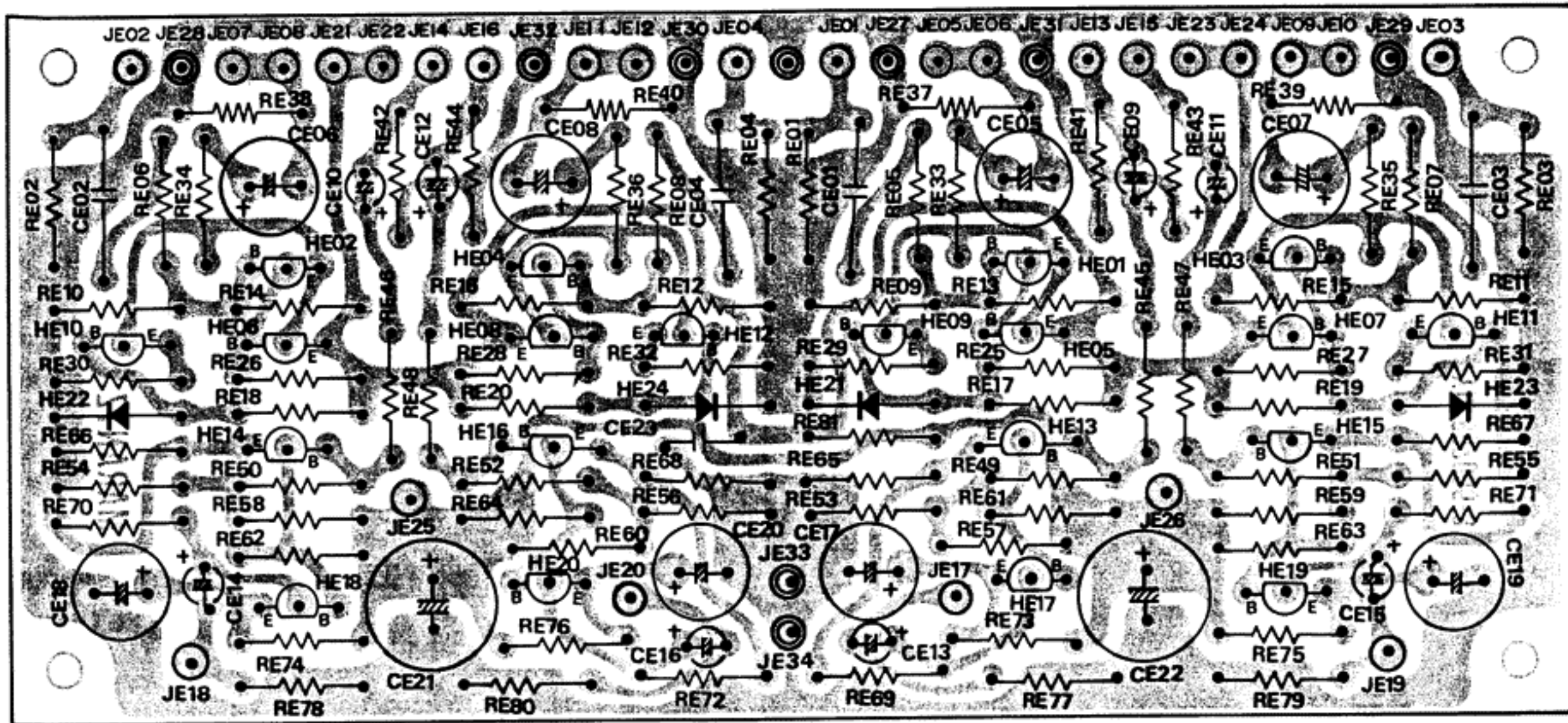

Figure 19. Buffer and Pre-Amplifier Assembly PE01 Component Locations

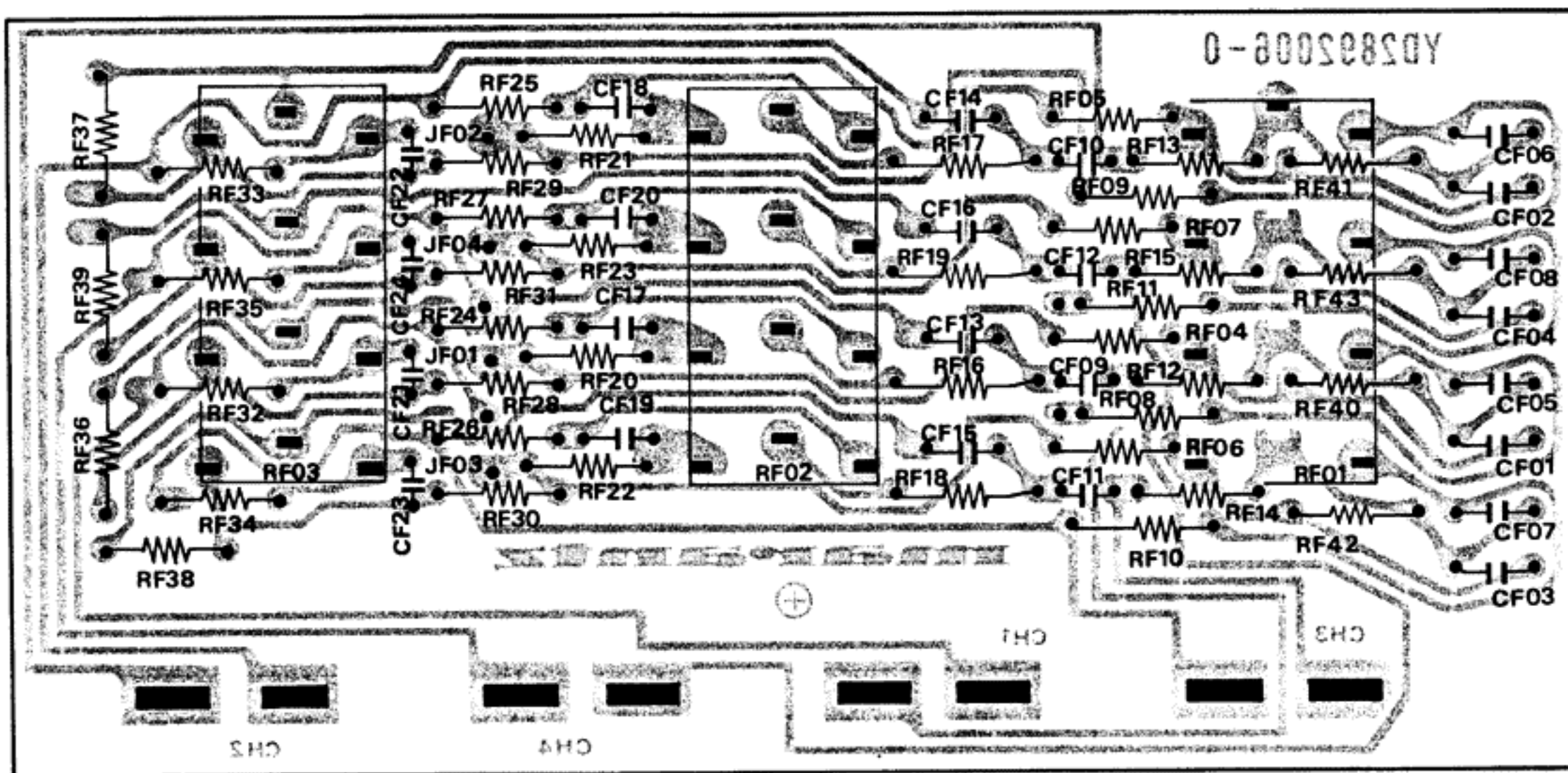

Figure 20. Tone Control Unit Assembly PF01 Component Locations

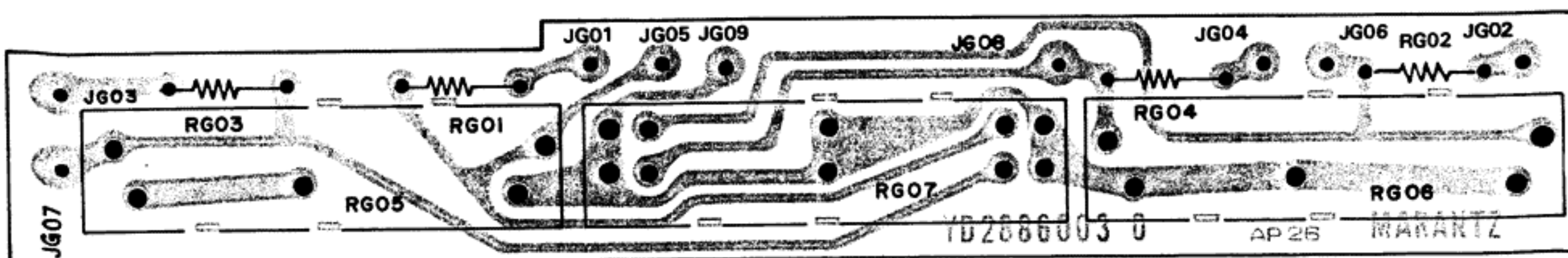

Figure 21. Balance Control Unit Assembly PG01 Component Locations

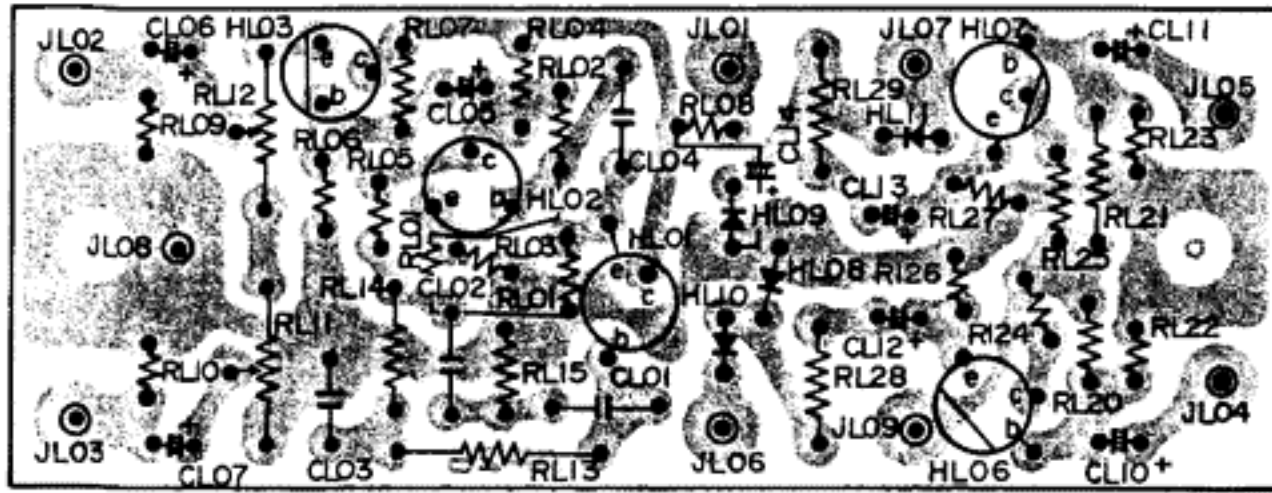

Figure 22. 400Hz Oscillator and Meter Driver Assembly
PL01 Component Locations

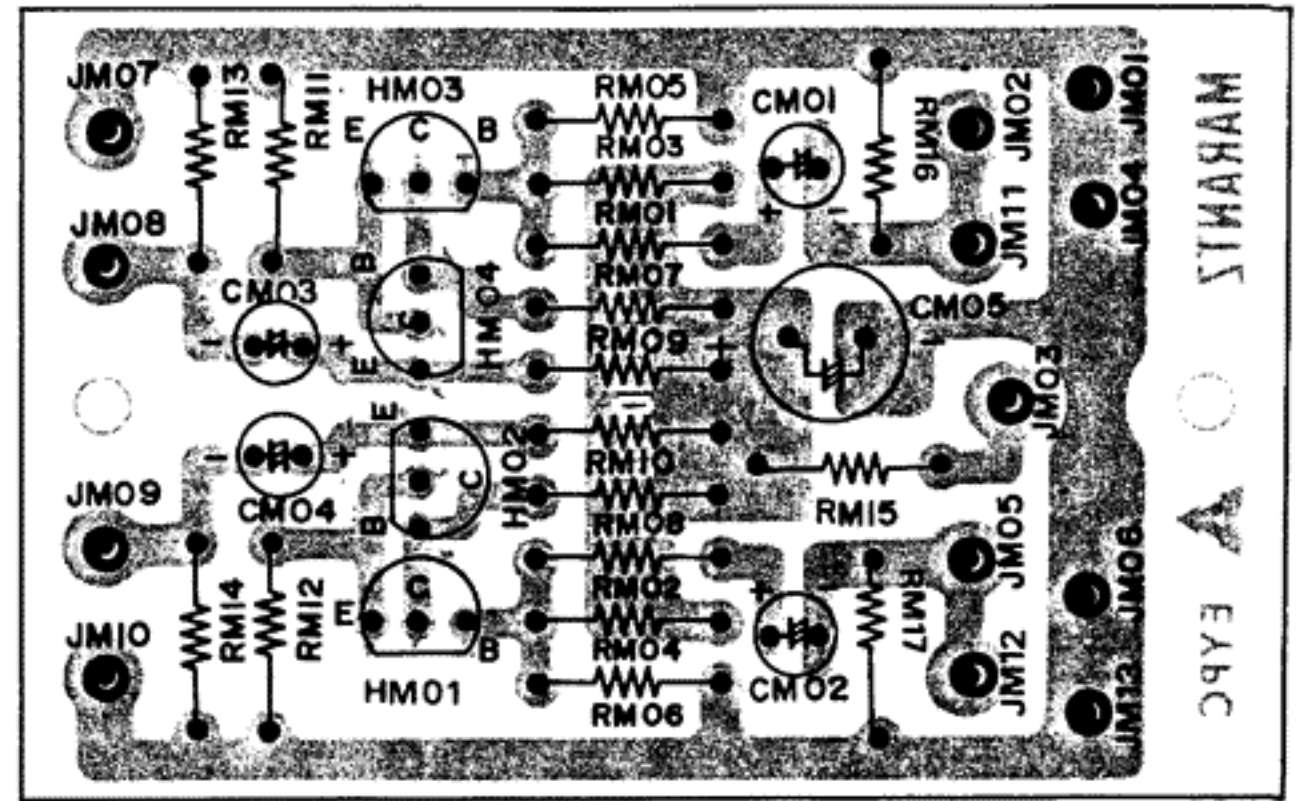

Figure 23. Phase Converter Assembly
PM01 Component Locations

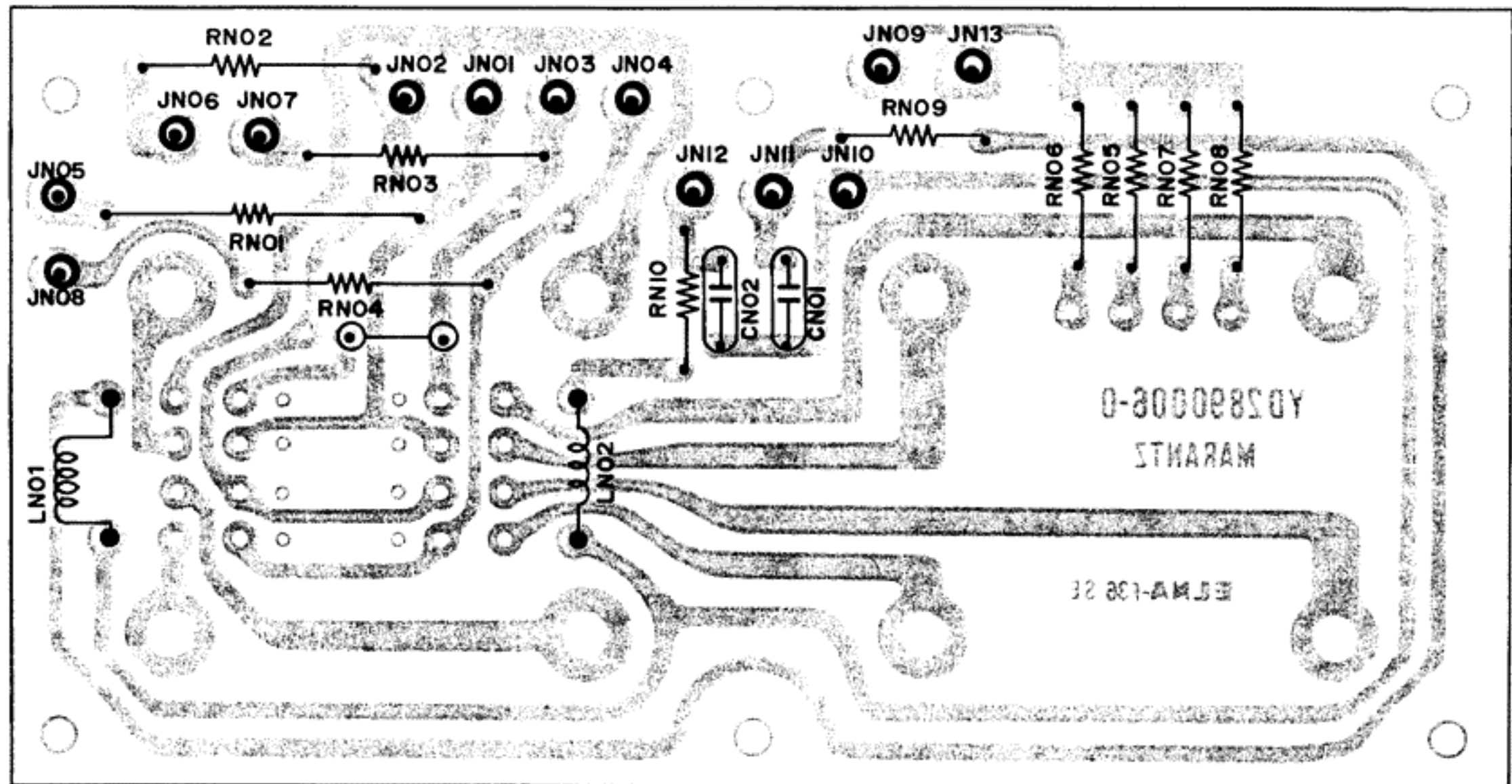

Figure 24. Speaker Protector Assembly PN01 Component Locations

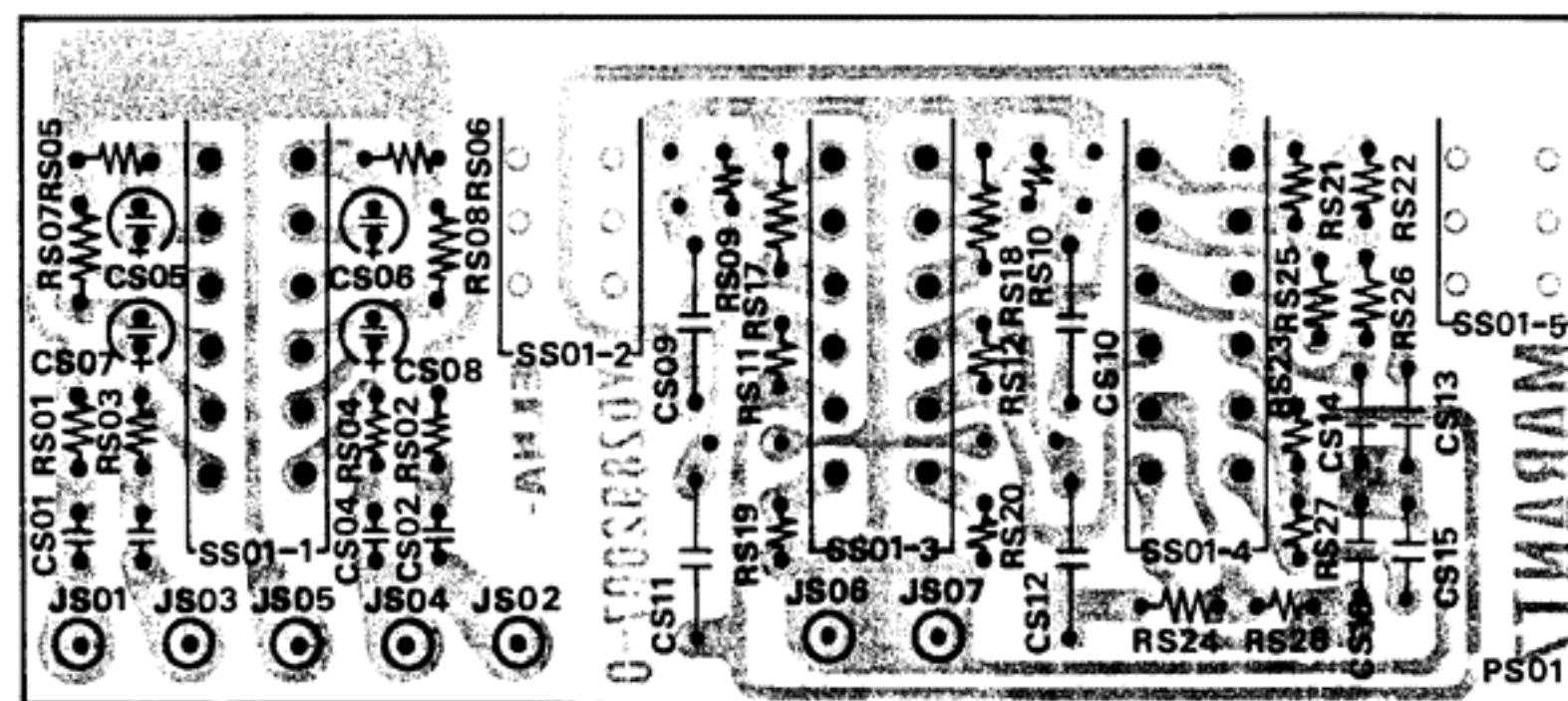

Figure 25. Switch Unit Assembly PS01 Component Locations

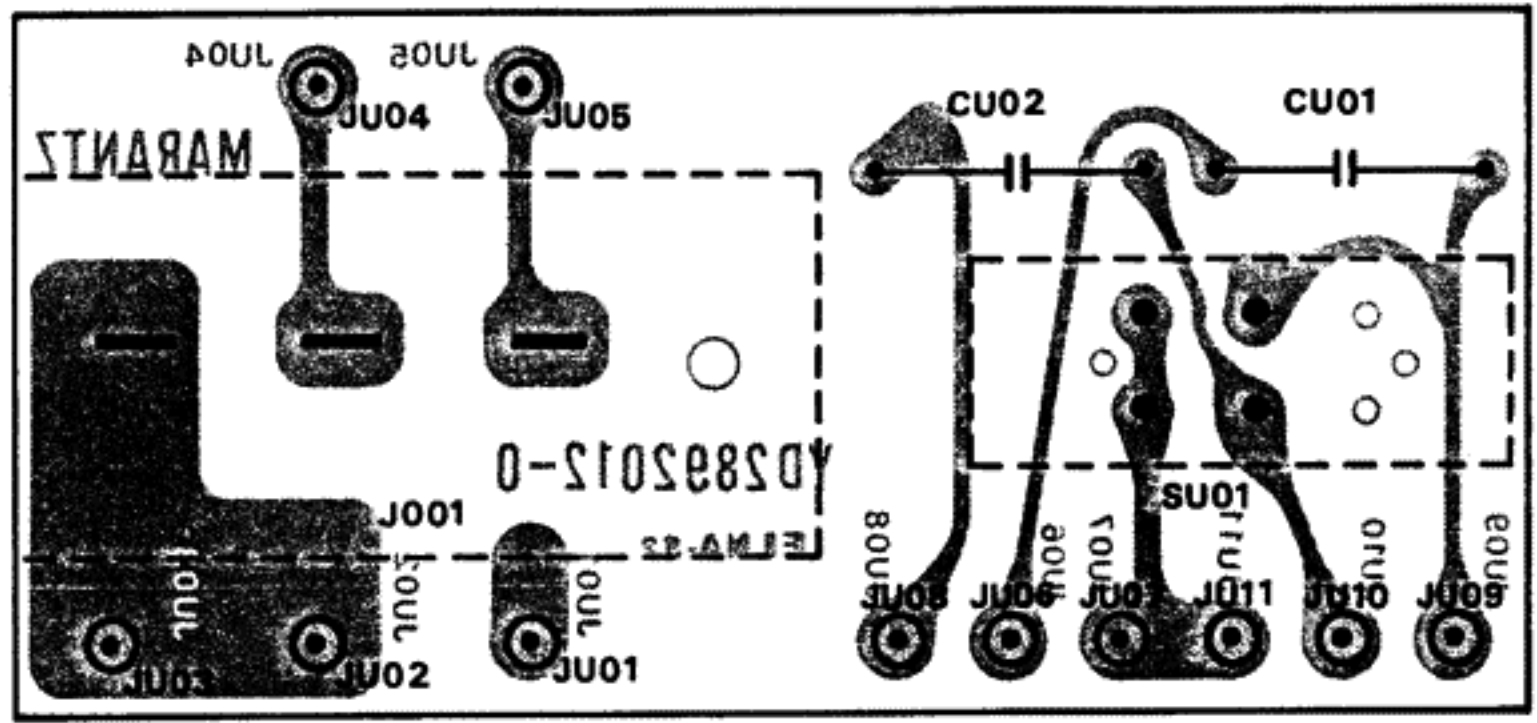

Figure 26. FM De-emphasis Assembly PU01 Component Locations

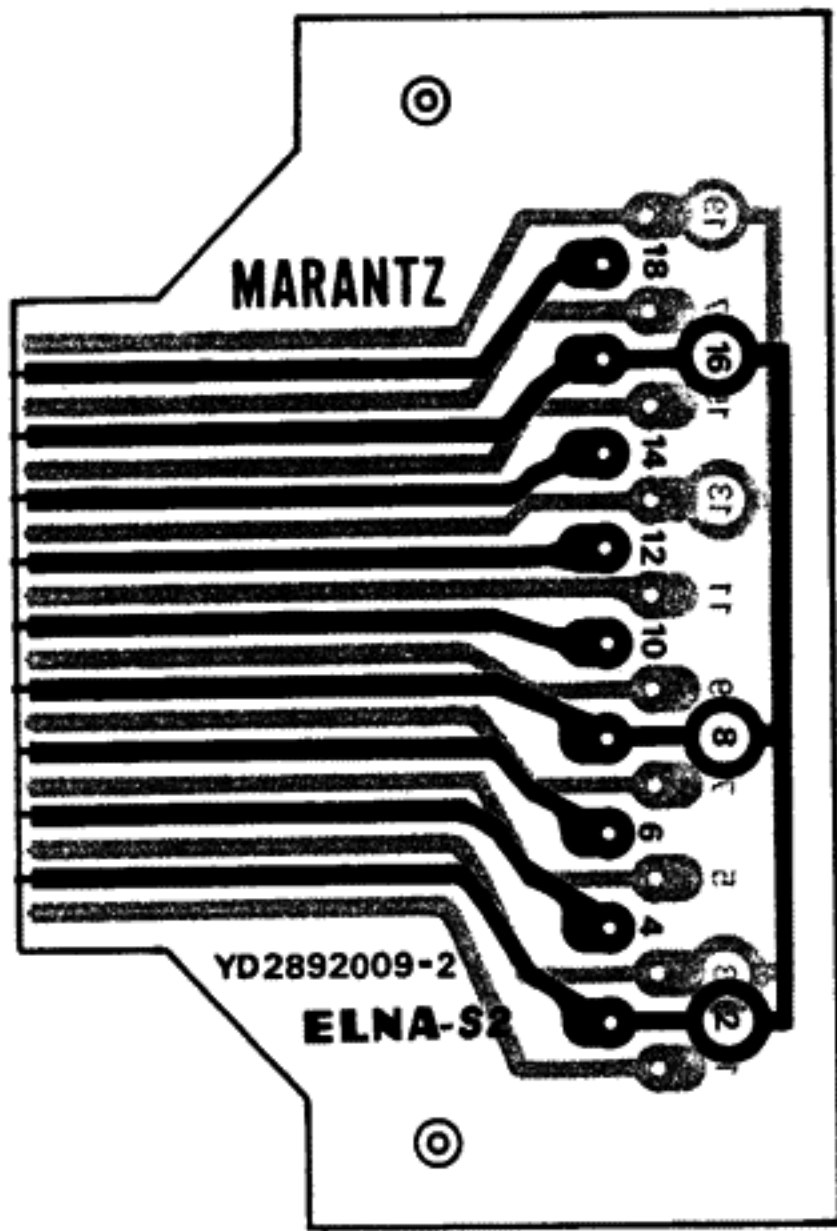

Figure 27. Dolby Terminal Assembly PV01 Component Locations

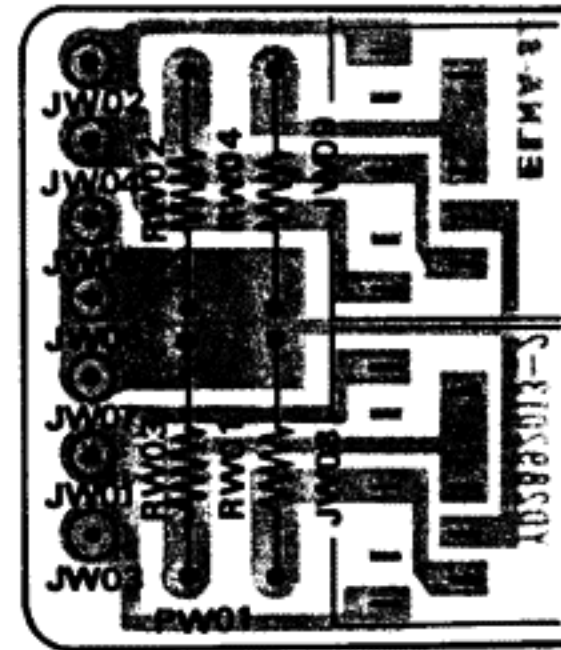

Figure 28. Headphone Assembly PW01 Component Locations

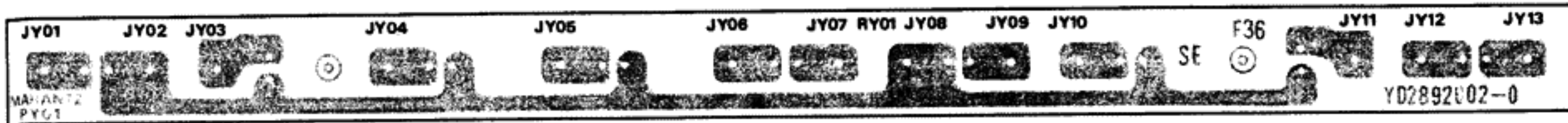

Figure 29. Selector Lamps Assembly PY01 Component Locations

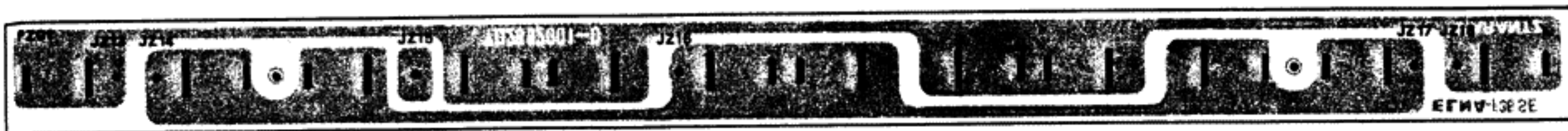

Figure 30. Dial Lamps Assembly PZ01 Component Locations

NOTE

REF. DESIG.	MARANTZ PART NO.	DESCRIPTION	REF. DESIG.	MARANTZ PART NO.	DESCRIPTION
		SEMICONDUCTORS			
H101	HF200191A	FET, 2SK19 (Y)	R162	RT0510414	100K Ω
H102	HF200191A	FET, 2SK19 (Y)	R163	RT0510114	100 Ω
H103	HT305351B	Transistor, 2SC535 (B)	R164	RT0556214	5.6K Ω
		MISCELLANEOUS	R165	RT0510114	100 Ω
J101	YP1000094	Plug	R166	RT0510414	100K Ω
J106					
			R167	RT0512414	120K Ω
			R168	RT0515214	1.5K Ω
					CAPACITORS
2011	281810903	Shield	C151	DK1710301	Ceramic, 0.01 μ F \pm 20%
2012	281810904	Shield x 2	C152	DF6545101	Film, 450PF \pm 5%
2013	281810905	Shield	C153	DF1747305	Film, 0.047 μ F \pm 20%
			C154	DK1840302	Ceramic, 0.04 μ F +80%, -20%
2002	281810950	Shield K	C155	EA1070169	Electroly, 100 μ F, 16V
			C157	DK1710301	Ceramic, 0.01 μ F \pm 20%
2016	281810908	Shield	C158	DK1710301	Ceramic, 0.01 μ F \pm 20%
2017	114325901	Bush x 2	C159	DD1620001	Ceramic, 20PF \pm 10%
2018	114325902	Bush x 2	C160	EA4750359	Electroly, 47 μ F, 35V
			C161	EA3350509	Electroly, 3.3 μ F, 50V
2021	281805102	Guide	C162	DK1710201	Ceramic, 1000PF \pm 20%
			C163	DF1710301	Film, 0.01 μ F \pm 20%
2106	51570306B	P.H. Tapt Screw x 4	C164	DK1710301	Ceramic, 0.01 μ F \pm 20%
2111	51100304A	B.H.M. Screw x 2	C165	DF1610401	Film, 0.1 μ F \pm 10%
			C166	DK1840302	Ceramic, 0.04 μ F +80%, -20%
2112	51040308A	F.H.M. Screw x 2	C167	EA1070169	Electroly, 100 μ F, 16V
2113	51100304E	B.H.M. Screw x 3	C168	EA1050509	Electroly, 1 μ F, 50V
2114	51060305E	P.H.M. Screw x 3	C169	DK1710301	Ceramic, 0.01 μ F \pm 20%
			C170	EA1050509	Electroly, 1 μ F, 50V
					SEMICONDUCTORS
2121	54040402N	Spring Washer	H151	HC1000301	IC, HA1151
2122	53110403E	Hexagon Nut	H152	HT306441C	Transistor, 2SC644 (T)
					COILS & TRANSFORMERS
2007	289016006	Bracket	L151	LA1001017	RF Coil
2008	281816008	Bracket	L152	LO1001048	OSC Coil
2009	281811201	Shaft	L153	LI1028002	I.F.T.
			L154	LI1001064	I.F.T.
C003	CA0330002	Variable Cap., AM 3 Gang	L155	LC1332002	Choke Coil, 3.3 μ H
			L156	LC1332002	Choke Coil, 3.3 μ H
					MISCELLANEOUS
2032	289215901	Drum	J151	YP1000113	Plug
2034	71101569M	Spring	J161		
2026	281805850	Gear K x 2			
2117	51064019A	Screw x 4			
			P200	YD2892014 ZZ2892014	P.W. Board, FM IF P.W. Board Assembly
P150	YD2890001 ZZ2892101	P.W. Board, AM P.W. Board Assembly			RESISTORS
		RESISTORS			All resistors are \pm5% and $\frac{1}{4}$W, unless otherwise indicated.
		All resistors are \pm 5% and $\frac{1}{4}$ W, unless otherwise indicated.	R201	RT0515114	150 Ω
R151	RT0515114	150 Ω	R202	RT0582214	8.2K Ω
R152	RA0103025	Trimming, 10K Ω (B)	R203	RT0518314	18K Ω
R153	RT0556214	5.6K Ω	R204	RT0510214	1K Ω
R154	RT0510314	10K Ω	R205	RT0533114	330 Ω
R155	RT0510314	10K Ω	R207	RT0547014	47 Ω
R156	RT0510214	1K Ω	R208	RT0533214	3.3K Ω
R157	RT0530114	300 Ω	R209	RT0515214	1.5K Ω
R158	RT0533314	33K Ω	R210	RT0515114	150 Ω
R159	RT0510414	100K Ω	R211	RA0101001	Trimming, 100 Ω (B)
R160	RT0520214	2.0K Ω			
R161	RT0515214	1.5K Ω	R212	RT0510214	1K Ω
			R213	RT0533114	330 Ω

REF. DESIG.	MARANTZ PART NO.	DESCRIPTION
R215	RT0547014	47Ω
R216	RT0533214	3.3KΩ
R217	RT0515214	1.5KΩ
R218	RT0515114	150Ω
R219	RT0510214	1KΩ
R220	RT0533114	330Ω
R223	RT0547314	47KΩ
R224	RT0547014	47Ω
R225	RT0515214	1.5KΩ
R226	RT0533214	3.3KΩ
R227	RT0515114	150Ω
R228	RT0556114	560Ω
R229	RT0533114	330Ω
R231	RT0575014	75Ω
R232	RT0510414	100KΩ
R234	RT0568314	68KΩ
R235	RT0547014	47Ω
R236	RT0582114	820Ω
R237	RT0556314	56KΩ
R238	RT0582114	820Ω
R239	RT0515214	1.5KΩ
R240	RT0533214	3.3KΩ
R241	RT0515114	150Ω
R242	RT0510214	1KΩ
R243	RT0510214	1KΩ
R244	RT0515114	150Ω
R246	RT0568314	68KΩ
R248	RT0547014	47Ω
R249	RT0515114	150Ω
R250	RT0510414	100KΩ
R251	RT0582214	8.2KΩ
R252	RT0515314	15KΩ
R253	RT0510214	1KΩ
R254	RT0510214	1KΩ
R255	RT0515114	150Ω
R257	RT0539314	39KΩ
R258	RT0522314	22KΩ
R259	RT0582114	820Ω
R260	RT0510414	100KΩ
R261	RT0515114	150Ω
R262	RT0582214	8.2KΩ
R263	RT0515314	15KΩ
R264	RT0510214	1KΩ
R265	RT0510214	1KΩ
R266	RT0510114	100Ω
R267	RT0515114	150Ω
R268	RT0515114	150Ω
R269	RT0510414	100KΩ
R270	RT0582214	8.2KΩ
R271	RT0515314	15KΩ
R272	RT0510214	1KΩ
R273	RT0510114	100Ω
R274	RT0527214	2.7KΩ
R275	RT0582114	820Ω
R276	RT0582114	820Ω
R277	RT0582114	820Ω
R278	RT0568214	6.8KΩ
R279	RT0568214	6.8KΩ
R280	RT0510114	100Ω
R281	RT0556314	56KΩ
R282	RT0522314	22KΩ
R283	RT0510114	100Ω

REF. DESIG.	MARANTZ PART NO.	DESCRIPTION
R284	RT0510414	100KΩ
R285	RT0518414	180KΩ
R286	RT0510114	100Ω
R287	RT0522214	2.2KΩ
R288	RT0510114	100Ω
R289	RT0510114	100Ω
R290	RT0512114	120Ω
R291	RT0582214	8.2KΩ
R292	RT0518314	18KΩ
R293	RT0522214	2.2KΩ
R294	RT0527314	27KΩ
R296	RT0533314	33KΩ
CAPACITORS		
C201	DK1810301	Ceramic, 0.01μF +80%, -20%
C202	DK1810301	Ceramic, 0.01μF +80%, -20%
C203	DK1840302	Ceramic, 0.04μF +80%, -20%
C204	EA1060169	Electroly, 10μF, 16V
C205	EA1060169	Electroly, 10μF, 16V
C206	DK1840302	Ceramic, 0.04μF +80%, -20%
C207	DK1810301	Ceramic, 0.01μF +80%, -20%
C208	EA1060169	Electroly, 10μF, 16V
C209	DK1840302	Ceramic, 0.04μF +80%, -20%
C210	DK1810301	Ceramic, 0.01μF +80%, -20%
C211	DD1540001	Ceramic, 40PF ± 5%
C213	DK1810301	Ceramic, 0.01μF +80%, -20%
C214	DD1540001	Ceramic, 40PF ± 5%
C215	DK1810301	Ceramic, 0.01μF +80%, -20%
C217	DK1840302	Ceramic, 0.04μF +80%, -20%
C218	EA1060169	Electroly, 10μF, 16V
C219	EA1060169	Electroly, 10μF, 16V
C220	DK1840302	Ceramic, 0.04μF +80%, -20%
C221	DK1810301	Ceramic, 0.01μF +80%, -20%
C222	DK1810301	Ceramic, 0.01μF +80%, -20%
C223	DD1540001	Ceramic, 40PF ± 5%
C225	DK1810301	Ceramic, 0.01μF +80%, -20%
C226	DK1810301	Ceramic, 0.01μF +80%, -20%
C227	DK1810301	Ceramic, 0.01μF +80%, -20%
C228	DD1540001	Ceramic, 40PF ± 5%
C229	EA1060169	Electroly, 10μF, 16V
C230	DK1840302	Ceramic, 0.04μF +80%, -20%
C232	DK1810301	Ceramic, 0.01μF +80%, -20%
C233	DD1540001	Ceramic, 40PF ± 5%
C234	DK1810301	Ceramic, 0.01μF +80%, -20%
C235	DK1810301	Ceramic, 0.01μF +80%, -20%
C236	DK1810301	Ceramic, 0.01μF +80%, -20%
C237	DK1810301	Ceramic, 0.01μF +80%, -20%
C238	DK1840302	Ceramic, 0.04μF +80%, -20%
C239	DD1620101	Ceramic, 200PF ± 10%
C240	DD1620101	Ceramic, 200PF ± 10%
C241	DD1620101	Ceramic, 200PF ± 10%
C242	EA1060169	Electroly, 10μF, 16V
C243	EA1070109	Electroly, 100μF, 10V
C244	EA1060169	Electroly, 10μF, 16V
C245	EA1060169	Electroly, 10μF, 16V
C246	DK1840302	Ceramic, 0.04μF +80%, -20%
C247	DK1840302	Ceramic, 0.04μF +80%, -20%
C248	EA1060169	Electroly, 10μF, 16V
C249	EA1070169	Electroly, 100μF, 16V
C250	EA1060169	Electroly, 10μF, 16V
C251	DK1810301	Ceramic, 0.01μF +80%, -20%
C252	DD1540001	Ceramic, 40PF ± 5%
C253	DK1840302	Ceramic, 0.04μF +80%, -20%

REF. DESIG.	MARANTZ PART NO.	DESCRIPTION
C254	DD1540001	Ceramic, 40PF ± 5%
C255	DD1620101	Ceramic, 200PF ± 10%
C256	EV1050352	Electroly, 1μF ± 20%, 35V
C257	DD1620101	Ceramic, 200PF ± 10%
C258	DK1810301	Ceramic, 0.01μF +80%, -20%
C259	DK1840302	Ceramic, 0.04μF +80%, -20%
CERAMIC FILTERS		
F201	FF1107003	SFA 10.7MC
F202	FF1107003	SFA 10.7MC
F203	FF1107003	SFA 10.7MC
F204	FF1107003	SFA 10.7MC
F205	FF1107003	SFA 10.7MC
F206	FF1107003	SFA 10.7MC
F207	FF1107003	SFA 10.7MC
F208	FF1107003	SFA 10.7MC
COILS & TRANSFORMERS		
L201	LI1401623	I.F.T., FM DET.
L202	LC1332002	Choke Coil, 3.3μH
SEMICONDUCTORS		
H201	HT308291C	Transistor, 2SC829 (C)
H202	HT308291C	Transistor, 2SC829 (C)
H203	HT308291C	Transistor, 2SC829 (C)
H204	HT308291C	Transistor, 2SC829 (C)
H205	HT308291C	Transistor, 2SC829 (C)
H206	HT308291C	Transistor, 2SC829 (C)
H207	HT308291C	Transistor, 2SC829 (C)
H208	HT308291C	Transistor, 2SC829 (C)
H209	HT308291C	Transistor, 2SC829 (C)
H210	HT306441B	Transistor, 2SC644 (S)
H211	HD2001105	Diode, 1S1555
H212	HD2001105	Diode, 1S1555
H213	HD2001105	Diode, 1S1555
H214	HD2001105	Diode, 1S1555
H215	HD2001105	Diode, 1S1555
H216	HD2001105	Diode, 1S1555
H217	HD2001105	Diode, 1S1555
H218	HD2001105	Diode, 1S1555
H219	HD1000302	Diode, 20A90M
H220	HD1000302	Diode, 20A90M
H221	HD1000105	Diode, 1N60
H222	HD1000105	Diode, 1N60
H223	HD1000105	Diode, 1N60
H224	HD1000105	Diode, 1N60
H225	HD1000105	Diode, 1N60
H226	HD1000105	Diode, 1N60
H227	HD1000105	Diode, 1N60
H228	HD1000105	Diode, 1N60
H229	HD1000105	Diode, 1N60
H230	HD1000105	Diode, 1N60
H231	HD1000105	Diode, 1N60
H232	HD1000105	Diode, 1N60
H233	HD1000302	Diode, 20A90M
MISCELLANEOUS		
J201	YP1000113	Plug
J211		
G201	BF2230006	Printed Comp., 1KΩ + 0.022μF
G202	BF1020002	Printed Comp., 100KΩ + 1000PF
G203	BF1020001	Printed Comp., 27KΩ + 1000PF

REF. DESIG.	MARANTZ PART NO.	DESCRIPTION
G204	BF2010004	Printed Comp., 27KΩ + 200PF
G205	BF2010004	Printed Comp., 27KΩ + 200PF
G206	BF2010004	Printed Comp., 27KΩ + 200PF
G207	BF2010004	Printed Comp., 27KΩ + 200PF
P300	YD2890003 ZZ2892103	P.W. Board, MPX P.W. Board Assembly
RESISTORS		
All resistors are ±5% and ¼W, unless otherwise indicated.		
R301	RA0202011	Trimming, 2KΩ (B)
R302	RT0522414	220KΩ
R303	RT0556314	56KΩ
R304	RT0568314	68KΩ
R305	RT0510114	100Ω
R306	RT0518414	180KΩ
R307	RT0522414	220KΩ
R308	RT0512414	120KΩ
R309	RT0510414	100KΩ
R310	RT0568214	6.8KΩ
R311	RA0502020	Trimming, 5KΩ (B)
R312	RT0516314	16KΩ
R313	RT0510214	1KΩ
R314	RT0522414	220KΩ
R315	RT0510214	1KΩ
R316	RT0510214	1KΩ
R317	RT0539214	3.9KΩ
R318	RT0539214	3.9KΩ
R319	RT0522414	220KΩ
R320	RT0522314	22KΩ
R321	RT0510114	100Ω
R322	RT0510014	10Ω
R323	RT0522414	220KΩ
R324	RT0522414	220KΩ
R325	RT0530314	30KΩ
R326	RT0530314	30KΩ
R327	RT0510414	100KΩ
R328	RT0510414	100KΩ
R329	RT0510514	1MΩ
R330	RT0510514	1MΩ
R331	RT0510214	1KΩ
R332	RT0510214	1KΩ
R333	RT0522314	22KΩ
R334	RT0522314	22KΩ
R335	RT0510114	100Ω
R336	RT0510114	100Ω
R337	RT0582214	8.2KΩ
R338	RT0582214	8.2KΩ
R339	RT0547114	470Ω
R340	RT0547114	470Ω
R341	RT0522414	220KΩ
R342	RT0522414	220KΩ
R343	RT0539214	3.9KΩ
R344	RT0556414	560KΩ
R345	RT0515314	15KΩ
R346	RT0512414	120KΩ
R347	RT0510114	100Ω
R348	RT0522414	220KΩ
R349	RT0556214	5.6KΩ
R350	RT0510314	10KΩ

REF. DESIG.	MARANTZ PART NO.	DESCRIPTION	
R351	RT0510114	100Ω	
R352	RT0533314	33KΩ	
R353	RT0510114	100Ω	
R354	RT0510414	100KΩ	
R355	RT0527314	27KΩ	
R356	RT0510414	100KΩ	
R357	RT0510214	1KΩ	
R358	RT0510114	100Ω	
R359	RT0527314	27KΩ	
R360	RT0533314	33KΩ	
R361	RT0522414	220KΩ	
R362	RA0104018	Trimming,	100KΩ (B)
R363	RA0103025	Trimming,	10KΩ (B)
R364	RT0522214	2.2KΩ	
R365	RT0510114	100Ω	
R366	RT0510314	10KΩ	
R367	RT0510114	100Ω	
R368	RT0527414	270KΩ	
R369	RT0515314	15KΩ	
R370	RT0512314	12KΩ	
R371	RT0522114	220Ω	
R372	RT0527414	270KΩ	
R373	RT0533314	33KΩ	
R374	RA0103025	Trimming,	10KΩ (B)
R375	RT0510114	100Ω	
R376	RT0510414	100KΩ	
R377	RT0510414	100KΩ	
R378	RT0556214	5.6KΩ	
R379	RT0533214	3.3KΩ	
CAPACITORS			
C301	DF1622205	Film,	2200PF ± 10%
C302	EA3360109	Electroly,	33μF, 10V
C303	DF1722305	Film,	0.022μF ± 20%
C304	EA1060169	Electroly,	10μF, 16V
C305	DF5547101	Film,	470PF ± 5%
C306	EA1060169	Electroly,	10μF, 16V
C307	EQ4740501	Electroly,	0.47μF ± 20%, 50V
C308	EQ2240501	Electroly,	0.22μF ± 20%, 50V
C309	EQ2240501	Electroly,	0.22μF ± 20%, 50V
C310	DF1747301	Film,	0.047μF ± 20%
C311	DF1515205	Film,	1500PF ± 5%
C312	DF1515205	Film,	1500PF ± 5%
C313	DD1536101	Ceramic,	360PF ± 5%
C314	DD1536101	Ceramic,	360PF ± 5%
C315	DF1533205	Film,	3300PF ± 5%
C316	DF1533205	Film,	3300PF ± 5%
C317	DF1515205	Film,	1500PF ± 5%
C318	DF1515205	Film,	1500PF ± 5%
C319	DF1522205	Film,	2200PF ± 5%
C320	DF1522205	Film,	2200PF ± 5%
C321	DF1510205	Film,	1000PF ± 5%
C322	DF1510205	Film,	1000PF ± 5%
C323	EV2240351	Electroly,	0.22μF ± 20%, 35V
C324	EV2240351	Electroly,	0.22μF ± 20%, 35V
C325	EV1050352	Electroly,	1μF ± 20%, 35V
C326	EV1050352	Electroly,	1μF ± 20%, 35V
C327	EA2270259	Electroly,	220μF, 25V
C328	EA2270169	Electroly,	220μF, 16V
C329	EA1060169	Electroly,	10μF, 16V
C330	DK1840302	Ceramic,	0.04μF +80%, -20%
C331	EA1050509	Electroly,	1μF, 50V
C332	EA1060169	Electroly,	10μF, 16V

REF. DESIG.	MARANTZ PART NO.	DESCRIPTION	
C333	DD1210001	Ceramic,	10P ± 1PF
C334	DF1668301	Film,	0.068μF ± 10%
C335	DF1740301	Film,	0.04μF ± 20%
C336	DK1810402	Ceramic,	0.1μF +80%, -20%
C337	EA4750359	Electroly,	4.7μF, 35V
C338	EA1050509	Electroly,	1μF, 50V
C339	DK1840302	Ceramic,	0.04μF +80%, -20%
C340	DK1840302	Ceramic,	0.04μF +80%, -20%
C341	DK1840302	Ceramic,	0.04μF +80%, -20%
SEMICONDUCTORS			
H301	HF200301C	FET,	2SK30 (Y)
H302	HT308281D	Transistor,	2SC828 (S)
H303	HT308281D	Transistor,	2SC828 (S)
H304	HT307322A	Transistor,	2SC732 (B or G)
H305	HT307322A	Transistor,	2SC732 (B or G)
H306	HT104942A	Transistor,	2SA494 (G or Y)
H307	HT104942A	Transistor,	2SA494 (G or Y)
H308	HT308281D	Transistor,	2SC828 (S)
H309	HT308281D	Transistor,	2SC828 (S)
H310	HT308281D	Transistor,	2SC828 (S)
H311	HT308281D	Transistor,	2SC828 (S)
H312	HF200300A	FET,	2SK30 A
H313	HT308281D	Transistor,	2SC828 (S)
H314	HT308281D	Transistor,	2SC828 (S)
H315	HT308281D	Transistor,	2SC828 (S)
H316	HT308281D	Transistor,	2SC828 (S)
H317	HT308281D	Transistor,	2SC828 (S)
H318	HD1000105	Diode,	1N60
H319	HD1000105	Diode,	1N60
H320	HD2001105	Diode,	1S1555
H321	HC1000401	I.C.,	HA1156
COILS			
L301	LS1029004	MPX Coil,	56mH
L302	LS1029004	MPX Coil,	56mH
L303	LS1029005	MPX Coil,	43mH
L304	LS1029005	MPX Coil,	43mH
L305	LC2105001	Choke Coil,	1mH
MISCELLANEOUS			
J301			
J322	YP1000113	Plug	
P400	YD2892008 ZZ2892008	P.W. Board, Phono Amp P.W. Board Assembly	
RESISTORS			
All resistors are ±5% and ¼W, unless otherwise indicated.			
R401	RT0556314	56KΩ	
R402	RT0556314	56KΩ	
R403	RT0547114	470Ω	
R404	RT0547114	470Ω	
R405	RN0533314	33KΩ	
R406	RN0510514	1MΩ	
R407	RN0510514	1MΩ	
R408	RA0104015	Trimming,	100KΩ (B)
R409	RA0104015	Trimming,	100KΩ (B)
R410	RN0527314	27KΩ	
R411	RN0527314	27KΩ	

REF. DESIG.	MARANTZ PART NO.	DESCRIPTION
R412	RT0562114	620Ω
R413	RT0562114	620Ω
R414	RT0522514	2.2MΩ
R415	RT0522514	2.2MΩ
R416	RN0522514	2.2MΩ
R417	RN0522514	2.2MΩ
R418	RN0527414	270KΩ
R419	RN0527414	270KΩ
R420	RT0547314	47KΩ
R421	RT0547314	47KΩ
R422	RT0522214	2.2KΩ
R423	RT0522214	2.2KΩ
R424	RN0568414	680KΩ
R425	RN0568414	680KΩ
R426	RN0510414	100KΩ
R427	RN0510414	100KΩ
R428	RN0547314	47KΩ
R429	RN0547314	47KΩ
R430	RT0547014	47Ω
R431	RT0547014	47Ω
R432	RN0533214	3.3KΩ
R433	RN0533214	3.3KΩ
R434	RT0510114	100Ω
R435	RT0547014	47Ω
R436	RT0547014	47Ω
CAPACITORS		
C401	EV1050256	Electroly, 1μF ± 20%, 25V
C402	EV1050256	Electroly, 1μF ± 20%, 25V
C403	EE4760163	Electroly, 47μF ± 20%, 16V
C404	EE4760163	Electroly, 47μF ± 20%, 16V
C405	DD1540004	Ceramic, 40PF ± 5%, NPO
C406	DD1540004	Ceramic, 40PF ± 5%, NPO
C407	DD1104001	Ceramic, 4PF ± 0.5PF
C408	DD1104001	Ceramic, 4PF ± 0.5PF
C409	DF6556201	Film, 5600PF ± 5%
C410	DF6556201	Film, 5600PF ± 5%
C411	DF6516201	Film, 1600PF ± 5%
C412	DF6516201	Film, 1600PF ± 5%
C413	ED1070351	Electroly, 100μF, 35V
C414	DF1710550	Film, 1μF ± 20%, 250V
C415	DF1710550	Film, 1μF ± 20%, 250V
C416	DD1650001	Ceramic, 50PF ± 10%
C417	DD1650001	Ceramic, 50PF ± 10%
SEMICONDUCTORS		
H401	HT313441E	Transistor, 2SC1344 (E)
H402	HT313441E	Transistor, 2SC1344 (E)
H403	HT313442A	Transistor, 2SC1344 (D or E)
H404	HT313442A	Transistor, 2SC1344 (D or E)
H405	HT304580R	Transistor, 2SC458L (B)
H406	HT304580R	Transistor, 2SC458L (B)
H407	HD2000121	Diode, 1S-2473C (Ye)
H408	HD2000121	Diode, 1S-2473C (Ye)
H409	HV0000206	Varistor, VD1212
MISCELLANEOUS		
J401	YP1000113	Plug
J408		
P500	YD2889004 ZZ2889004	P.W. Board, Vari-Matrix P.W. Board Assembly

REF. DESIG.	MARANTZ PART NO.	DESCRIPTION
RESISTORS		
All resistors are ±5% and ¼W.		
R501	RT0515414	150KΩ
R502	RT0515414	150KΩ
R503	RT0556314	56KΩ
R504	RT0556314	56KΩ
R505	RT0522414	220KΩ
R506	RT0522414	220KΩ
R507	RT0533414	330KΩ
R508	RT0533414	330KΩ
R509	RT0556214	5.6KΩ
R510	RT0556214	5.6KΩ
R511	RT0556214	5.6KΩ
R512	RT0556214	5.6KΩ
R513	RT0568214	6.8KΩ
R514	RT0568214	6.8KΩ
R515	RT0568214	6.8KΩ
R516	RT0568214	6.8KΩ
R517	RT0547314	47KΩ
R518	RT0547314	47KΩ
R519	RT0547314	47KΩ
R520	RT0547314	47KΩ
R521	RT0547414	470KΩ
R522	RT0547414	470KΩ
R523	RT0568314	68KΩ
R524	RT0568314	68KΩ
R525	RT0512514	1.2MΩ
R526	RT0512514	1.2MΩ
R527	RT0510214	1KΩ
R528	RT0510214	1KΩ
R529	RT0522314	22KΩ
R530	RT0522314	22KΩ
R531	RT0515314	15KΩ
R532	RT0515314	15KΩ
R533	RT0510414	100KΩ
R534	RT0510414	100KΩ
R535	RT0500214	1KΩ
R536	RT0510214	1KΩ
R537	RT0522114	220Ω
MISCELLANEOUS		
J501	YP1000113	Plug
J513		
CAPACITORS		
C501	EE4740501	Electroly, 0.47μF ± 20%, 50V
C502	EE4740501	Electroly, 0.47μF ± 20%, 50V
C503	EE3350501	Electroly, 3.3μF ± 20%, 50V
C504	EE3350501	Electroly, 3.3μF ± 20%, 50V
C505	EE3350501	Electroly, 3.3μF ± 20%, 50V
C506	EE3350501	Electroly, 3.3μF ± 20%, 50V
C507	DF1647305	Film, 0.047μF ± 10%, 50V
C508	DF1647305	Film, 0.047μF ± 10%, 50V
C509	DF1647305	Film, 0.047μF ± 10%, 50V
C510	DF1647305	Film, 0.047μF ± 10%, 50V
C511	EE3350501	Electroly, 3.3μF ± 20%, 50V
C512	EE3350501	Electroly, 3.3μF ± 20%, 50V
C513	EE3350501	Electroly, 3.3μF ± 20%, 50V
C514	EE3350501	Electroly, 3.3μF ± 20%, 50V
C515	EA2260359	Electroly, 22μF, 35V
C516	EA2260359	Electroly, 22μF, 35V
C517	DD1650101	Ceramic, 500PF ± 10%
C518	DD1650101	Ceramic, 500PF ± 10%

REF. DESIG.	MARANTZ PART NO.	DESCRIPTION
C519	EA1070359	Electroly, 100 μ F, 35V
		TRANSISTORS
H501	HT313272A	2SC1327 (S or T)
H502	HT313272A	2SC1327 (S or T)
H503	HT313272A	2SC1327 (S or T)
H504	HT313272A	2SC1327 (S or T)
H505	HT106401L	2SA640 (L)
H506	HT106401L	2SA640 (L)
1910	51100304S	B.H.M. Screw x 8
PV01	YD2892009	P.W. Board, Dolby Terminal
1903	289216007	Bracket
1904	289212001	Insulator
1906	289210106	Insulator x 4
1907	289210107	Insulator x 4
1912	51100305A	B.H.M. Screw x 2
P600	YD2886008 ZZ2892108	P.W. Board, Dolby x 2 P.W. Board Assembly x 2
		RESISTORS
		All resistors are $\pm 5\%$ and $\frac{1}{4}W$, unless otherwise indicated.
R601	RT0547414	470K Ω x 2
R602	RT0547414	470K Ω x 2
R603	RT0510414	100K Ω x 2
R604	RT0510414	100K Ω x 2
R605	RT0533214	3.3K Ω x 2
R606	RT0533214	3.3K Ω x 2
R607	RT0562114	620 Ω x 2
R608	RT0562114	620 Ω x 2
R609	RT0539314	39K Ω x 2
R610	RT0539314	39K Ω x 2
R611	RT0568214	6.8K Ω x 2
R612	RT0568214	6.8K Ω x 2
R613	RT0510114	100 Ω x 2
R614	RT0510114	100 Ω x 2
R615	RT0522214	2.2K Ω x 2
R616	RT0522214	2.2K Ω x 2
R617	RT0512114	120 Ω x 2
R618	RT0512114	120 Ω x 2
R619	RT0556114	560 Ω x 2
R620	RT0556114	560 Ω x 2
R621	RT0533314	33K Ω x 2
R622	RT0533314	33K Ω x 2
R623	RT0515414	150K Ω x 2
R624	RT0515414	150K Ω x 2
R625	RT0518414	180K Ω x 2
R626	RT0518414	180K Ω x 2
R627	RT0527314	27K Ω x 2
R628	RT0527314	27K Ω x 2
R629	RT0582214	8.2K Ω x 2
R630	RT0582214	8.2K Ω x 2
R631	RT0515414	150K Ω x 2
R632	RT0515414	150K Ω x 2
R633	RT0522314	22K Ω x 2

REF. DESIG.	MARANTZ PART NO.	DESCRIPTION
R634	RT0522314	22K Ω x 2
R635	RT0527214	2.7K Ω x 2
R636	RT0527214	2.7K Ω x 2
R637	RT0533314	33K Ω x 2
R638	RT0533314	33K Ω x 2
R639	RT0547314	47K Ω x 2
R640	RT0547314	47K Ω x 2
R643	RT0527414	270K Ω x 2
R644	RT0527414	270K Ω x 2
R645	RT0547314	47K Ω x 2
R646	RT0547314	47K Ω x 2
R647	RT0533214	3.3K Ω x 2
R648	RT0533814	3.3K Ω x 2
R649	RT0515214	1.5K Ω x 2
R650	RT0515214	1.5K Ω x 2
R651	RT0522314	22K Ω x 2
R652	RT0522314	22K Ω x 2
R653	RA0103022	Variable, 10K Ω (B) x 2
R654	RA0103022	Variable, 10K Ω (B) x 2
R655	RT0527214	2.7K Ω x 2
R656	RT0527214	2.7K Ω x 2
R657	RT0568414	680K Ω x 2
R658	RT0568414	680K Ω x 2
R659	RA0102020	Variable, 1K Ω (B) x 2
R660	RA0102020	Variable, 1K Ω (B) x 2
R661	RT0515314	15K Ω x 2
R662	RT0515314	15K Ω x 2
R663	RT0582214	8.2K Ω x 2
R664	RT0582214	8.2K Ω x 2
R665	RT0510314	10K Ω x 2
R666	RT0510314	10K Ω x 2
R667	RT0582214	8.2K Ω x 2
R668	RT0582214	8.2K Ω x 2
R669	RT0582214	8.2K Ω x 2
R670	RT0582214	8.2K Ω x 2
R671	RT0533314	33K Ω x 2
R672	RT0533314	33K Ω x 2
R673	RT0512414	120K Ω x 2
R674	RT0512414	120K Ω x 2
R675	RT0547314	47K Ω x 2
R676	RT0547314	47K Ω x 2
R677	RT0527214	2.7K Ω x 2
R678	RT0527214	2.7K Ω x 2
R679	RT0510214	1K Ω x 2
R680	RT0510214	1K Ω x 2
R681	RT0533014	33 Ω x 2
R682	RT0533014	33 Ω x 2
R683	RT0547014	47 Ω x 2
R684	RT0547014	47 Ω x 2
R685	RT0515314	15K Ω x 2
R686	RT0515314	15K Ω x 2
R687	RT0527414	270K Ω x 2
R688	RT0527414	270K Ω x 2
R689	RT0527414	270K Ω x 2
R690	RT0527414	270K Ω x 2
R691	RT0522414	220K Ω x 2
R692	RT0522414	220K Ω x 2
R693	RC1010112	100 Ω \pm 10%, $\frac{1}{2}W$ x 2
		CAPACITORS
C601	EE3350251	Electroly, 3.3 μ F, 25V x 2
C602	EE3350251	Electroly, 3.3 μ F, 25V x 2

REF. DESIG.	MARANTZ PART NO.	DESCRIPTION	REF. DESIG.	MARANTZ PART NO.	DESCRIPTION
C603	DF6610101	Film, 100PF ± 10% x 2	H616	HT104941C	Transistor, 2SA494 (Y) x 2
C605	DF1510205	Film, 1000PF ± 5% x 2	H617	HT306441B	Transistor, 2SC644 (S) x 2
C607	EA1060169	Electroly, 10μF, 16V x 2	H618	HT306441B	Transistor, 2SC644 (S) x 2
C608	EA1060169	Electroly, 10μF, 16V x 2	H621	HD1000105	Diode, 1N60 x 2
C609	EA1060169	Electroly, 10μF, 16V x 2	H622	HD1000105	Diode, 1N60 x 2
C610	EA1060169	Electroly, 10μF, 16V x 2	H623	HD2000121	Diode, 1S2473 x 2
C611	EA1060169	Electroly, 10μF, 16V x 2	H624	HD2000121	Diode, 1S2473 x 2
C612	EA1060169	Electroly, 10μF, 16V x 2	H625	HD3003109	Diode, WZ-081 x 2
C613	EA1060169	Electroly, 10μF, 16V x 2	H626	HD2000121	Diode, 1S2473 x 2
C614	EA1060169	Electroly, 10μF, 16V x 2	H627	HD2000121	Diode, 1S2473 x 2
C615	DD1582001	Ceramic, 82PF ± 5% x 2	H628	HD2000121	Diode, 1S2473 x 2
C616	DD1530102	Ceramic, 300PF ± 5% x 2	H629	HD2000121	Diode, 1S2473 x 2
C617	DF1556205	Film, 5600PF ± 5% x 2	1820	51100406S	B.H.M. Screw x 4
C618	DF1556205	Film, 5600PF ± 5% x 2	1821	51100306S	B.H.M. Screw x 4
C619	DF1527305	Film, 0.027μF ± 5% x 2	H001	HT107451B	Transistor, 2SA745 (O)
C620	DF1527305	Film, 0.027μF ± 5% x 2	H002	HT314031B	Transistor, 2SC1403 (O)
C621	DF1547205	Film, 4700PF ± 5% x 2	H003	HT107451B	Transistor, 2SA745 (O)
C622	DF1547205	Film, 4700PF ± 5% x 2	H004	HT314031B	Transistor, 2SC1403 (O)
C623	EA1060169	Electroly, 10μF, 16V x 2	H005	HT107451B	Transistor, 2SA745 (O)
C624	EA1060169	Electroly, 10μF, 16V x 2	H006	HT314031B	Transistor, 2SC1403 (O)
C625	DF1610405	Film, 0.1μF ± 10% x 2	H007	HT107451B	Transistor, 2SA745 (O)
C626	DF1610405	Film, 0.1μF ± 10% x 2	H008	HT314031B	Transistor, 2SC1403 (O)
C627	EA4760109	Electroly, 47μF, 10V x 2	J019	YJ0500019	Socket, Power TR
C628	EA4760109	Electroly, 47μF, 10V x 2	J026		
C629	DF1610405	Film, 0.1μF ± 10% x 2	1803	289226701	Heat Sink x 2
C630	DF1610405	Film, 0.1μF ± 10% x 2	1805	289016003	Bracket x 4
C631	EA1060169	Electroly, 10μF, 16V x 2	1807	281810104	Support x 4
C632	EA1060169	Electroly, 10μF, 16V x 2	1817	282100501	Clamper x 2
C633	DF1610405	Film, 0.1μF ± 10% x 2	1813	289216004	Bracket x 2
C634	DF1610405	Film, 0.1μF ± 10% x 2	1822	51100306S	B.H.M. Screw x 4
C635	EA1060169	Electroly, 10μF, 16V x 2	1823	51100314E	B.H.M. Screw x 16
C636	EA1060169	Electroly, 10μF, 16V x 2	1825	51380306T	R.H. Tap Screw x 8
C637	DF1610405	Film, 0.1μF ± 10% x 2	1826	51380306T	R.H. Tap Screw x 4
C638	DF1610405	Film, 0.1μF ± 10% x 2	1827	51570406B	P.H. Tapt Screw x 4
C639	DF1633405	Film, 0.33μF ± 10% x 2	1828	62041760W	Lug x 4
C640	DF1633405	Film, 0.33μF ± 10% x 2	1829	54050400R	T.L. Washer OR x 4
C641	EA2270259	Electroly, 220μF, 25V x 2	J036	YJ0700007	Socket
L601	LC2226004	COIL Choke Coil, 22mH x 2	J037	YJ0700007	Socket
J613	YP1000109	Plug x 2	1804	289212004	Insulator x 2
J614	YP1000109	Plug x 2	1824	51102604E	B.H.M. Screw x 2
J618	YP1000109	Plug x 2	1809	289226702	Heat Sink x 2
J620	YP1000109	Plug x 2	1810	289226703	Heat Sink x 8
J621	YP1000109	Plug x 2	1811	281811806	Spacer x 8
H601	HT306441B	Transistor, 2SC644 (S) x 2	1814	289205601	Buffer x 4
H602	HT306441B	Transistor, 2SC644 (S) x 2	1816	289205501	Collar x 8
H603	HT306441B	Transistor, 2SC644 (S) x 2	1830	53110301E	Heagon Nut x 24
H604	HT306441B	Transistor, 2SC644 (S) x 2	1831	54050300R	T.L. Washer OR x 8
H605	HT104941C	Transistor, 2SA494 (Y) x 2	1832	51100316E	B.H.M. Screw x 12
H606	HT104941C	Transistor, 2SA494 (Y) x 2	1833	54040302N	Spring Washer x 12
H607	HT306441B	Transistor, 2SC644 (S) x 2			
H608	HT306441B	Transistor, 2SC644 (S) x 2			
H609	HT306441B	Transistor, 2SC644 (S) x 2			
H610	HT306441B	Transistor, 2SC644 (S) x 2			
H611	HF200301E	FET, 2SK30 (D) x 2			
H612	HF200301E	FET, 2SK30 (D) x 2			
H613	HT306441B	Transistor, 2SC644 (S) x 2			
H614	HT306441B	Transistor, 2SC644 (S) x 2			
H615	HT1049491C	Transistor, 2SA494 (Y) x 2			

REF. DESIG.	MARANTZ PART NO.	DESCRIPTION
1834	54020301E	Flat Washer P x 4
P700	YD2892004 ZZ2892004	P.W. Board, Power Amp x 2 P.W. Board Assembly x 2
RESISTORS		
All resistors are $\pm 5\%$ and $\frac{1}{4}W$, unless otherwise indicated.		
R701	RT0547414	470K Ω x 2
R702	RT0547414	470K Ω x 2
R703	RT0510214	1K Ω x 2
R704	RT0510214	1K Ω x 2
R705	RT0547314	47K Ω x 2
R706	RT0547314	47K Ω x 2
R707	RT0510214	1K Ω x 2
R708	RT0510214	1K Ω x 2
R709	RT0527214	2.7K Ω x 2
R710	RT0527214	2.7K Ω x 2
R711	RT0527414	270K Ω x 2
R712	RT0527414	270K Ω x 2
R713	RT0512314	12K Ω x 2
R714	RT0512314	12K Ω x 2
R717	RT0520114	200 Ω x 2
R718	RT0520114	200 Ω x 2
R719	RT0515314	15K Ω x 2
R720	RT0515314	15K Ω x 2
R721	RA0502017	Trimming, 5K Ω (B) x 2
R722	RA0502017	Trimming, 5K Ω (B) x 2
R723	RT0515314	15K Ω x 2
R724	RT0515314	15K Ω x 2
R725	GF0527212	2.7K Ω $\pm 5\%$, $\frac{1}{2}W$ x 2
R726	GF0527212	2.7K Ω $\pm 5\%$, $\frac{1}{2}W$ x 2
R727	RT0547314	47K Ω x 2
R728	RT0547314	47K Ω x 2
R729	RT0547014	47 Ω x 2
R730	RT0547014	47 Ω x 2
R731	RT0582014	82 Ω x 2
R732	RT0582014	82 Ω x 2
R733	RT0556314	56K Ω x 2
R734	RT0556314	56K Ω x 2
R735	RT0510114	100 Ω x 2
R736	RT0510114	100 Ω x 2
R737	GF0547012	47 Ω $\pm 5\%$, $\frac{1}{2}W$ x 2
R738	GF0547012	47 Ω $\pm 5\%$, $\frac{1}{2}W$ x 2
R739	RA0102020	Trimming, 1K Ω (B) x 2
R740	RA0102020	Trimming, 1K Ω (B) x 2
R741	GF0510112	100 Ω $\pm 5\%$, $\frac{1}{2}W$ x 2
R742	GF0510112	100 Ω $\pm 5\%$, $\frac{1}{2}W$ x 2
R743	GF0582012	82 Ω $\pm 5\%$, $\frac{1}{2}W$ x 2
R744	GF0582012	82 Ω $\pm 5\%$, $\frac{1}{2}W$ x 2
R745	GF0510112	100 Ω $\pm 5\%$, $\frac{1}{2}W$ x 2
R746	GF0510112	100 Ω $\pm 5\%$, $\frac{1}{2}W$ x 2
R747	RT0510214	1K Ω x 2
R748	RT0510214	1K Ω x 2
R749	GF0568114	680 Ω x 2
R750	GF0568114	680 Ω x 2
R751	GF0518214	1.8K Ω x 2
R752	GF0518214	1.8K Ω x 2
R753	GF0518214	1.8K Ω x 2
R754	GF0518214	1.8K Ω x 2
R755	RT0551214	5.1K Ω x 2

REF. DESIG.	MARANTZ PART NO.	DESCRIPTION
R756	RT0551214	5.1K Ω x 2
R757	GF0510114	100 Ω x 2
R758	GF0510114	100 Ω x 2
R759	GF0510114	100 Ω x 2
R760	GF0510114	100 Ω x 2
R761	BW1000205	0.2 Ω +0.2 Ω $\pm 10\%$, 5W x 2
R762	BW1000205	0.2 Ω +0.2 Ω $\pm 10\%$, 5W x 2
R763	RT0510014	10 Ω x 2
R764	RT0510014	10 Ω x 2
R765	GJ0510002	10 Ω $\pm 5\%$, 2W x 2
R766	GJ0510002	10 Ω $\pm 5\%$, 2W x 2
R767	GJ0502201	2.2 Ω $\pm 5\%$, 1W x 2
R768	GJ0502201	2.2 Ω $\pm 5\%$, 1W x 2
R769	RT0539014	39 Ω x 2
R770	RT0539014	39 Ω x 2
R771	RT0515214	1.5K Ω x 2
R772	RT0515214	1.5K Ω x 2
R773	RT0533014	33 Ω x 2
R774	RT0533014	33 Ω x 2
CAPACITORS		
C701	EV2250256	Electroly, 2.2 μ F $\pm 20\%$, 25V x 2
C702	EV2250256	Electroly, 2.2 μ F $\pm 20\%$, 25V x 2
C703	DD1620101	Ceramic, 200PF $\pm 10\%$ x 2
C704	DD1620101	Ceramic, 200PF $\pm 10\%$ x 2
C705	DK1610150	Ceramic, 100PF $\pm 10\%$, 500V x 2
C706	DK1610150	Ceramic, 100PF $\pm 10\%$, 500V x 2
C707	DD1620101	Ceramic, 200PF $\pm 10\%$ x 2
C708	DD1620101	Ceramic, 200PF $\pm 10\%$ x 2
C709	EA4740501	Electroly, 0.47 μ F, 50V x 2
C710	EA4740501	Electroly, 0.47 μ F, 50V x 2
C711	EE4760163	Electroly, 47 μ F, 16V x 2
C712	EE4760163	Electroly, 47 μ F, 16V x 2
C713	ED2270509	Electroly, 220 μ F, 50V x 2
C714	ED2270509	Electroly, 220 μ F, 50V x 2
C715	ED2270509	Electroly, 220 μ F, 50V x 2
C716	ED2270509	Electroly, 220 μ F, 50V x 2
C717	DD1003050	Ceramic, 3PF ± 0.25 PF, 500V x 2
C718	DD1003050	Ceramic, 3PF ± 0.25 PF, 500V x 2
C719	DF1722305	Film, 0.022 μ F $\pm 20\%$ x 2
C720	DF1722305	Film, 0.022 μ F $\pm 20\%$ x 2
C721	DK1610150	Ceramic, 100PF $\pm 10\%$, 500V x 2
C722	DK1610150	Ceramic, 100PF $\pm 10\%$, 500V x 2
C723	DK1610150	Ceramic, 100PF $\pm 10\%$, 500V x 2
C724	DK1610150	Ceramic, 100PF $\pm 10\%$, 500V x 2
C725	DF1733305	Film, 0.033 μ F $\pm 20\%$, 50V x 2
C726	DF1733305	Film, 0.033 μ F $\pm 20\%$, 50V x 2
C727	DF1710305	Film, 0.01 μ F $\pm 20\%$ x 2
C728	DF1710305	Film, 0.01 μ F $\pm 20\%$ x 2
C729	DF1710305	Film, 0.01 μ F $\pm 20\%$ x 2
C730	DF1710305	Film, 0.01 μ F $\pm 20\%$ x 2
C731	DF1710452	Film, 0.1 μ F $\pm 20\%$, 200V x 2
C732	DF1710452	Film, 0.1 μ F $\pm 20\%$, 200V x 2
C733	DF1710301	Film, 0.01 μ F $\pm 20\%$ x 2
C734	DF1710301	Film, 0.01 μ F $\pm 20\%$ x 2
C735	EV1060036	Electroly, 10 μ F $\pm 20\%$, 3.15V x 2
C736	EV1060036	Electroly, 10 μ F $\pm 20\%$, 3.15V x 2
SEMICONDUCTORS		
H701	HT107221S	Transistor, 2SA722 (S) x 2
H702	HT107221S	Transistor, 2SA722 (S) x 2
H703	HT107221S	Transistor, 2SA722 (S) x 2
H704	HT107221S	Transistor, 2SA722 (S) x 2

REF. DESIG.	MARANTZ PART NO.	DESCRIPTION	REF. DESIG.	MARANTZ PART NO.	DESCRIPTION
H705	HT107221S	Transistor, 2SA722 (S) x 2	R810	GF0533212	3.3K Ω \pm 5%, $\frac{1}{2}$ W
H706	HT107221S	Transistor, 2SA722 (S) x 2	R811	GF0510012	10 Ω \pm 5%, $\frac{1}{2}$ W
H707	HT306271B	Transistor, 2SC627 (1) x 2	R813	RT0568214	6.8K Ω
H708	HT306271B	Transistor, 2SC627 (1) x 2	R814	RT0533314	33K Ω
H709	HT306271B	Transistor, 2SC627 (1) x 2	R815	RT0522314	22K Ω
H710	HT306271B	Transistor, 2SC627 (1) x 2	R816	RT0539314	39K Ω
H711	HT304581B	Transistor, 2SC458 (B) x 2	R817	RT0527414	270K Ω
H712	HT304581B	Transistor, 2SC458 (B) x 2	R818	GU1010312	10K Ω \pm 10%, $\frac{1}{2}$ W
H713	HT403571C	Transistor, 2SD357 (C) x 2	R819	GJ0522202	2.2K Ω \pm 5%, 2W
H714	HT205271C	Transistor, 2SB527 (C) x 2	R820	GJ0522202	2.2K Ω \pm 5%, 2W
H715	HT403571C	Transistor, 2SD357 (C) x 2			CAPACITORS
H716	HT205271C	Transistor, 2SB527 (C) x 2	C801	DK1810351	Ceramic, 0.01 μ F +100%, -0%, 500V
H717	HT309452A	Transistor, 2SC945 (Q or R) x 2	C802	DK1810351	Ceramic, 0.01 μ F +100%, -0%, 500V
H718	HT309452A	Transistor, 2SC945 (Q or R) x 2	C804	EA4770631	Electroly, 470 μ F, 63V
H719	HT309452A	Transistor, 2SC945 (Q or R) x 2	C805	EA2270509	Electroly, 220 μ F, 50V
H720	HT309452A	Transistor, 2SC945 (Q or R) x 2	C806	DF1747305	Film, 0.047 μ F, 30V
H721	HT107332B	Transistor, 2SA733 (Q or R) x 2	C807	EA1060509	Electroly, 10 μ F, 50V
H722	HT107332B	Transistor, 2SA733 (Q or R) x 2	C808	EA2270509	Electroly, 220 μ F, 50V
H723	HD3002709	Diode, WZ-140 x 2	C809	EA4770169	Electroly, 470 μ F, 16V
H724	HD3002709	Diode, WZ-140 x 2	C810	DF1710452	Film, 0.1 μ F \pm 20%, 200V
H725	HD2000121	Diode, 1S2473C (Ye) x 2	C811	DF1710452	Film, 0.1 μ F \pm 20%, 200V
H726	HD2000121	Diode, 1S2473C (Ye) x 2			
H727	HV0000508	Varistor, STV-3H (Y) x 2	C812	EA2260631	Electroly, 22 μ F, 63V
H728	HV0000508	Varistor, STV-3H (Y) x 2	C813	EA4760169	Electroly, 47 μ F, 16V
H729	HD2000121	Diode, 1S2473C (Ye) x 2	C814	EA2270109	Electroly, 220 μ F, 10V
H730	HD2000121	Diode, 1S2473C (Ye) x 2	C815	DF1710305	Film, 0.01 μ F \pm 20%, 50V
H731	HD2000221	Diode, 1S2472 (Gr) x 2			SEMICONDUCTORS
H732	HD2000221	Diode, 1S2472 (Gr) x 2	H801	HT403314A	Transistor, 2SD331 (C, D, E, F)
H733	HD2000221	Diode, 1S2472 (Gr) x 2	H802	HT307343A	Transistor, 2SC734 (O, R, Y)
H734	HD2000221	Diode, 1S2472 (Gr) x 2	H803	HT309452A	Transistor, 2SC945 (Q or R)
H735	HV0000206	Varistor, VD1212 x 2	H804	HT403314A	Transistor, 2SD331 (C, D, E, F)
H736	HV0000206	Varistor, VD1212 x 2	H805	HT309452A	Transistor, 2SC945 (Q or R)
H737	HT205272A	Transistor, 2SB527 (C or D) x 2	H806	HT313183A	Transistor, 2SC1318 (P, Q, R)
H738	HT205272A	Transistor, 2SB527 (C or D) x 2	H807	HT313183A	Transistor, 2SC1318 (P, Q, R)
H739	HV0000206	Varistor, VD1212 x 2	H808	HD3002309	Diode, WZ-071
H740	HV0000206	Varistor, VD1212 x 2	H809	HD3002709	Diode, WZ-140
			H810	HD2001103	Rectifier, DS-131B
		COILS			
L701	LJ2701515	x 2	H811	HD2001103	Rectifier, DS-131B
L702	LJ2701515	x 2	H812	HD2001008	Rectifier, 1S-2725 (S)
			H813	HD2001108	Rectifier, 1S-2725 (R)
					MISCELLANEOUS
1922	289216005	Bracket	J801	YP0600020	Plug, 7P
1929	51100305S	B.H.M. Screw x 2	J802	YJ0800017	Socket
1930	51100305S	B.H.M. Screw x 2	J803	YJ0800017	Socket
			J804		
			J811	YP1000099	Plug
P800	YD2892003 ZZ2892003	P.W. Board, Power Supply P.W. Board Assembly			
		RESISTORS	F801	FS1003002	Fuse, 0.3A
		All resistor are \pm 5% and $\frac{1}{4}$ W, unless otherwise indicated.	1917	51040312E	F.H.M. Screw x 4
R801	GJ0510001	10 Ω \pm 5%, 1W	1919	54050300R	T.L. Washer OR x 4
R802	RT0547214	4.7K Ω	1920	53110303E	Hexagon Nut x 8
R803	RT0547214	4.7K Ω	1921	289226704	Heat Sink x 2
R804	GF0539212	3.9K Ω \pm 5%, $\frac{1}{2}$ W			
R805	RT0522314	22K Ω	1923	289226706	Heat Sink
R806	RA0502017	Trimming, 5K Ω	1927	50062604B	B.H.M. Screw
R807	RT0556214	5.6K Ω			
R808	GJ0512103	120 Ω \pm 5%, 3W			
R809	GS1015105	150 Ω \pm 10%, 5W			

REF. DESIG.	MARANTZ PART NO.	DESCRIPTION
1931	51100305S	B.H.M. Screw x 2
1932	51100310E	B.H.M. Screw x 2
1933	54050300R	T.L. Washer OR x 2
1934	53110301E	Hexagon Nut x 2
PE01	YD2892005 ZZ2892005	P.W. Board, Buffer Pre. Amp. P.W. Board Assembly
RESISTORS		
All resistors are $\pm 5\%$ and $\frac{1}{4}W$.		
RE01	RT0515414	150K Ω
RE02	RT0515414	150K Ω
RE03	RT0515414	150K Ω
RE04	RT0515414	150K Ω
RE05	RT0510214	1K Ω
RE06	RT0510214	1K Ω
RE07	RT0510214	1K Ω
RE08	RT0510214	1K Ω
RE09	RN0510514	1M Ω
RE10	RN0510514	1M Ω
RE11	RN0510514	1M Ω
RE12	RN0510514	1M Ω
RE13	RN0591414	910K Ω
RE14	RN0591414	910K Ω
RE15	RN0591414	910K Ω
RE16	RN0591414	910K Ω
RE17	RT0536314	36K Ω
RE18	RT0536314	36K Ω
RE19	RT0536314	36K Ω
RE20	RT0536314	36K Ω
RE25	RT0522314	22K Ω
RE26	RT0522314	22K Ω
RE27	RT0522314	22K Ω
RE28	RT0522314	22K Ω
RE29	RT0575014	75 Ω
RE30	RT0575014	75 Ω
RE31	RT0575014	75 Ω
RE32	RT0575014	75 Ω
RE33	RT0522114	220 Ω
RE34	RT0522114	220 Ω
RE35	RT0522114	220 Ω
RE36	RT0522114	220 Ω
RE37	RT0510414	100K Ω
RE38	RT0510414	100K Ω
RE39	RT0510414	100K Ω
RE40	RT0510414	100K Ω
RE41	RT0547414	470K Ω
RE42	RT0547414	470K Ω
RE43	RT0547414	470K Ω
RE44	RT0510214	470K Ω
RE45	RT0510214	1K Ω
RE46	RT0510214	1K Ω
RE47	RT0510214	1K Ω
RE48	RT0510214	1K Ω
RE49	RT0547314	47K Ω
RE50	RT0547314	47K Ω
RE51	RT0547314	47K Ω
RE52	RT0547314	47K Ω
RE53	RT0510314	10K Ω
RE54	RT0510314	10K Ω
RE55	RT0510314	10K Ω

REF. DESIG.	MARANTZ PART NO.	DESCRIPTION
RE56	RT0510314	10K Ω
RE57	RT0510414	100K Ω
RE58	RT0510414	100K Ω
RE59	RT0510414	100K Ω
RE60	RT0510414	100K Ω
RE61	RT0527314	27K Ω
RE62	RT0527314	27K Ω
RE63	RT0527314	27K Ω
RE64	RT0527314	27K Ω
RE65	RT0510214	1K Ω
RE66	RT0510214	1K Ω
RE67	RT0510214	1K Ω
RE68	RT0510214	1K Ω
RE69	RT0591214	9.1K Ω
RE70	RT0591214	9.1K Ω
RE71	RT0591214	9.1K Ω
RE72	RT0591214	9.1K Ω
RE73	RT0510214	1K Ω
RE74	RT0510214	1K Ω
RE75	RT0510214	1K Ω
RE76	RT0510214	1K Ω
RE77	RT0522414	220K Ω
RE78	RT0522414	220K Ω
RE79	RT0522414	220K Ω
RE80	RT0522414	220K Ω
RE81	RT0547114	470 Ω
CAPACITORS		
CE01	DF1722405	Film, 0.22 μ F \pm 20%
CE02	DF1722405	Film, 0.22 μ F \pm 20%
CE03	DF1722405	Film, 0.22 μ F \pm 20%
CE04	DF1722405	Film, 0.22 μ F \pm 20%
CE05	EE2260251	Electroly, 22 μ F \pm 20%, 25V
CE06	EE2260251	Electroly, 22 μ F \pm 20%, 25V
CE07	EE2260251	Electroly, 22 μ F \pm 20%, 25V
CE08	EE2260251	Electroly, 22 μ F \pm 20%, 25V
CE09	EV2250256	Electroly, 2.2 μ F \pm 20%, 25V
CE10	EV2250256	Electroly, 2.2 μ F \pm 20%, 25V
CE11	EV2250256	Electroly, 2.2 μ F \pm 20%, 25V
CE12	EV2250256	Electroly, 2.2 μ F \pm 20%, 25V
CE13	EV4750356	Electroly, 4.7 μ F \pm 20%, 35V
CE14	EV4750356	Electroly, 4.7 μ F \pm 20%, 35V
CE15	EV3750356	Electroly, 4.7 μ F \pm 20%, 35V
CE16	EV4750356	Electroly, 4.7 μ F \pm 20%, 35V
CE17	EA4760359	Electroly, 47 μ F, 35V
CE18	EA4760359	Electroly, 47 μ F, 35V
CE19	EA4760359	Electroly, 47 μ F, 35V
CE20	EA4760359	Electroly, 47 μ F, 35V
CE21	EA2270359	Electroly, 220 μ F, 35V
CE22	EA2270359	Electroly, 220 μ F, 35V
CE23	DF1747305	Film, 0.047 μ F \pm 20%
SEMICONDUCTORS		
HE01	HT313452A	Transistor, 2SC1345 (D or E)
HE02	HT313452A	Transistor, 2SC1345 (D or E)
HE03	HT313452A	Transistor, 2SC1345 (D or E)
HE04	HT313452A	Transistor, 2SC1345 (D or E)
HE05	HT107202A	Transistor, 2SA720 (R or S)
HE06	HT107202A	Transistor, 2SA720 (R or S)
HE07	HT107202A	Transistor, 2SA720 (R or S)
HE08	HT107202A	Transistor, 2SA720 (R or S)
HE09	HT313182Q	Transistor, 2SC1318 (Q or R)
HE10	HT313182Q	Transistor, 2SC1318 (Q or R)

REF. DESIG.	MARANTZ PART NO.	DESCRIPTION	REF. DESIG.	MARANTZ PART NO.	DESCRIPTION
HE11	HT313182Q	Transistor, 2SC1318 (Q or R)	CL12	EA1060169	Electroly, 10 μ F, 16V
HE12	HT313182Q	Transistor, 2SC1318 (Q or R)	CL13	EA1060169	Electroly, 10 μ F, 16V
HE13	HT313452A	Transistor, 2SC1345 (D or E)	CL14	EA3360359	Electroly, 33 μ F, 35V
HE14	HT313452A	Transistor, 2SC1345 (D or E)			SEMICONDUCTORS
HE15	HT313452A	Transistor, 2SC1345 (D or E)	HL01	HT307331C	Transistor, 2SC733 (Gr)
HE16	HT313452A	Transistor, 2SC1345 (D or E)	HL02	HT307331C	Transistor, 2SC733 (Gr)
HE17	HT107632A	Transistor, 2SA763W (4 or 5)	HL03	HT307331C	Transistor, 2SC733 (Gr)
HE18	HT107632A	Transistor, 2SA763W (4 or 5)	HL06	HT307331C	Transistor, 2SC733 (Gr)
HE19	HT107632A	Transistor, 2SA763W (4 or 5)	HL07	HT307331C	Transistor, 2SC733 (Gr)
HE20	HT107632A	Transistor, 2SA763W (4 or 5)	HL08	HD1000105	Diode, 1N60
HE21	HV0000206	Varistor, VD1212	HL09	HD1000105	Diode, 1N60
HE22	HV0000206	Varistor, VD1212	HL10	HD1000105	Diode, 1N60
HE23	HV0000206	Varistor, VD1212	HL11	HD1000105	Diode, 1N60
HE24	HV0000206	Varistor, VD1212			MISCELLANEOUS
		MISCELLANEOUS	JL01		Plug
JE01		Plug	JL09	YP1000113	Plug
JE34	YP1000120	Plug			
			PM01	YD2890008	P.W. Board
PL01	YD2886009	P.W. Board, Dolby Tone & Meter		ZZ2892208	P.W. Board Assembly
	ZZ2886009	P.W. Board Assembly			RESISTORS
		RESISTORS			All resistors are $\pm 5\%$ and $\frac{1}{4}W$.
		All resistors are $\pm 5\%$ and $\frac{1}{4}W$, unless otherwise indicated.	RM01	RT0533114	330 Ω
RL01	RT0533214	3.3K Ω	RM02	RT0533114	330 Ω
RL02	RT0547314	47K Ω	RM03	RN0533414	330K Ω
RL03	RT0510114	100 Ω	RM04	RN0533414	330K Ω
RL04	RT0533214	3.3K Ω	RM05	RN0515414	150K Ω
RL05	RT0510214	1K Ω	RM06	RN0515414	150K Ω
RL06	RT0512314	12K Ω	RM07	RT0582314	82K Ω
RL07	RT0547314	47K Ω	RM08	RT0582314	82K Ω
RL08	RC1010212	1K Ω $\pm 10\%$, $\frac{1}{4}W$	RM09	RT0575214	7.5K Ω
RL09	RT0547214	4.7K Ω	RM10	RT0575214	7.5K Ω
RL10	RT0510214	1K Ω			
RL11	RA0501012	Trimming, 500 Ω (B)	RM11	RT0556214	5.6K Ω
RL12	RA0502019	Trimming, 5K Ω (B)	RM12	RT0556214	5.6K Ω
RL13	RT0556314	56K Ω	RM13	RT0547414	470K Ω
RL14	RT0556314	56K Ω	RM14	RT0547414	470K Ω
RL15	RT0547214	4.7K Ω	RM15	RT0533114	330 Ω
RL16	RT0533314	33K Ω	RM16	RT0547414	470K Ω
RL20	RT0568414	680K Ω	RM17	RT0547414	470K Ω
RL21	RT0568414	680K Ω			CAPACITORS
RL22	RT0533414	330K Ω	CM01	EE3350501	Electroly, 3.3 μ F, 50V
RL23	RT0533414	330K Ω	CM02	EE3350501	Electroly, 3.3 μ F, 50V
RL24	RT0533214	3.3K Ω	CM03	EE3350501	Electroly, 3.3 μ F, 50V
RL25	RT0533214	3.3K Ω	CM04	EE3350501	Electroly, 3.3 μ F, 50V
RL26	RT0515214	1.5K Ω	CM05	EA1070359	Electroly, 100 μ F, 35V
RL27	RT0515214	1.5K Ω			TRANSISTORS
RL28	RA0152004	Trimming, 1.5K Ω (B)	HM01	HT313452A	2SC1345 (D or E)
RL29	RA0152004	Trimming, 1.5K Ω (B)	HM02	HT107632A	2SA763 (4 or 5)
		CAPACITORS	HM03	HT313452A	2SC1345 (D or E)
CLO1	DF1515305	Film, 0.015 μ F $\pm 5\%$	HM04	HT107632A	2SA763 (4 or 5)
CLO2	DF1515305	Film, 0.015 μ F $\pm 5\%$			MISCELLANEOUS
CLO3	DF1668301	Film, 0.068 μ F $\pm 10\%$	JM01		Plug
CLO4	DF1710402	Film, 0.1 μ F $\pm 20\%$	JM13	YP1000113	Plug
CLO5	EA1060169	Electroly, 10 μ F, 16V			
CLO6	EA1060169	Electroly, 10 μ F, 16V			
CLO7	EA1060169	Electroly, 10 μ F, 16V			
CL10	EA1060169	Electroly, 10 μ F, 16V			
CL11	EA1060169	Electroly, 10 μ F, 16V			

REF. DESIG.	MARANTZ PART NO.	DESCRIPTION
0903	289216050	Bracket K
0909	289212201	Sticker
0913	257710602	Bearing
0914	141511801	Spacer
0915	51040306A	F.H.M. Screw x 2
0927	51100305A	B.H.M. Screw x 2
0933	51102604A	B.H.M. Screw x 2
1003	281816003	Bracket
1004	289216009	Bracket
1005	51100406A	B.H.M. Screw x 4
1011	51102605A	B.H.M. Screw x 6
1012	51060305A	P.H.M. Screw x 2
1013	51060305A	P.H.M. Screw x 6
1016	261105501	Collar x 2
1133	51042608A	F.H.M. Screw x 2
1616	51470306A	B.H.M. Screw S x 2
R007	RM0503057	Variable Resistor, 50K Ω
PG01	YD2886003 ZZ2886003	P.W. Board, Balance P.W. Board Assembly
RG01	RT0533214	3.3K Ω \pm 5%, 1/4W
RG02	RT0533214	3.3K Ω \pm 5%, 1/4W
RG03	RT0533214	3.3K Ω \pm 5%, 1/4W
RG04	RT0533214	3.3K Ω \pm 5%, 1/4W
RG05	RX0503006	Variable, 50K Ω (G)
RG06	RX0503006	Variable, 50K Ω (G)
RG07	RS0503017	Variable, 50K Ω (G)
MISCELLANEOUS		
JG01 } JG09	YP1000113	Plug
0926	289216003	Bracket
R008	RK0504010	Variable Resistor, 500K Ω (B)
R009	RK0504010	Variable Resistor, 500K Ω (B)
R010	RK0504010	Variable Resistor, 500K Ω (B)
R011	RK0504010	Variable Resistor, 500K Ω (B)
S008	SP0201009	Push Switch, Meter L/R
0931	285310901	Shield
0932	282112001	Insulator
S007	SP0801001	Push Switch, 400Hz Tone
1116	289205101	Guide
1118	289226252	Pulley K
1125	289226253	Pulley K

REF. DESIG.	MARANTZ PART NO.	DESCRIPTION
1132	51570305B	P.H. Tapt Screw x 4
PY01	YD2892002 ZZ2892002	P.W. Board, Function Lamp P.W. Board Assembly
MY01	IN1006301	Lamp, Dolby
MY02	IN1006301	Lamp, FM
MY03	IN1006301	Lamp, AM
MY04	IN1012011	Lamp, Stereo
MY05	IN1006302	Lamp, 4CH
MY06	IN1006301	Lamp, Tape-1
MY07	IN1006301	Lamp, Phono
MY08	IN1006301	Lamp, Aux
MY09	IN1006301	Lamp, Tape-2
RY01	RC1004712	Resistor, 4.7 Ω \pm 10%, 1/2W
JY01 } JY15	YP1000113	Plug
PZ01	YD2892001 ZZ2892001	P.W. Board, Dial Lamp P.W. Board Assembly
MZ01 } MZ06	IN1008007	Lamp, Dial Lamp
JZ01 } JZ10	YJ0800017	Socket
JZ11 } JZ16	YP1000113	Plug
1103	289227401	Reflector
1105	289227101	Holder
1106	51570305B	P.H. Tapt Screw x 2
1108	289227102	Holder
1109	51570305B	P.H. Tapt Screw x 2
1111	51100305A	B.H.M. Screw x 2
1113	51480306A	B.H.M. Screw F x 2
PS01	YD2892007 ZZ2892007	P.W. Board, Loudness Hi & Low Filter, Muting P.W. Board Assembly
RS01	RT0522314	22K Ω
RS02	RT0522314	22K Ω
RS03	RT0522314	22K Ω
RS04	RT0522314	22K Ω
RS05	RT0539214	3.9K Ω
RS06	RT0539214	3.9K Ω

REF. DESIG.	MARANTZ PART NO.	DESCRIPTION	REF. DESIG.	MARANTZ PART NO.	DESCRIPTION
RS07	RT0539214	3.9K Ω	0522	54050400R	T.L. Washer OR
RS08	RT0539214	3.9K Ω	0532	145525903	Bush
RS09	RT0510514	1M Ω	0533	145525903	Bush
RS10	RT0510514	1M Ω			
RS11	RT0510514	1M Ω	0616	51470306A	B.H.M. Screw S x 3
RS12	RT0510514	1M Ω	0619	53228059E	Nut
RS17	RT0547314	47K Ω	0620	51100304S	B.H.M. Screw x 2
RS18	RT0547314	47K Ω	0622	51100304S	B.H.M. Screw x 2
RS19	RT0547314	47K Ω	0631	51100314S	B.H.M. Screw x 2
RS20	RT0547314	47K Ω	0632	53110303E	Hexagon Nut x 2
RS21	RT0510514	1M Ω	J001	YT0304003	Terminal, AM FM Ant
RS22	RT0510514	1M Ω	J002	YT0201006	Terminal, Quad Radial
RS23	RT0510514	1M Ω	J003	YT0204003	Terminal, Front Phono TU Aux
RS24	RT0510514	1M Ω	J004	YT0208002	Terminal, Front Tape 1, 2
			J005	YT0202007	Terminal, Rear Aux
RS25	RT0547214	4.7K Ω	J006	YT0208002	Terminal, Rear Tape 1, 2
RS26	RT0547214	4.7K Ω	J007	YT0204003	Terminal, Pre Out Main In
RS27	RT0547214	4.7K Ω	J008	YT0204003	Terminal, Pre Out Main In
RS28	RT0547214	4.7K Ω			
		CAPACITORS	J015		
CS01	DK1668101	Ceramic, 680PF \pm 10%	} YP1000097	Plug	Pre Out \leftrightarrow Main In
CS02	DK1668101	Ceramic, 680PF \pm 10%	J018		
CS03	DK1668101	Ceramic, 680PF \pm 10%	J027	YJ0800012	Socket, Fuse Holder
CS04	DK1668101	Ceramic, 680PF \pm 10%			
CS05	EM1040251	Electroly, 0.1 μ F \pm 20%, 25V	F001	FS1080004	Fuse, 250V 8A (UL), For U.S.A.
CS06	EM1040251	Electroly, 0.1 μ F \pm 20%, 25V	F001	FS1080002	Fuse, 250V 8A, For CANADA
CS07	EM1040251	Electroly, 0.1 μ F \pm 20%, 25V	F002	FS2080091	Fuse, 250V 8A, For CANADA
CS08	EM1040251	Electroly, 0.1 μ F \pm 20%, 25V	G001	BF1040001	Printed Compo., 120 Ω +0.1 μ F
CS09	DF1668305	Film, 0.068 μ F \pm 10%	S006	SS0402022	Slide Switch, Remote Control
CS10	DF1668305	Film, 0.068 μ F \pm 10%	R001	RA0203007	Variable Resist, 20K Ω B Muting
CS11	DF1668305	Film, 0.068 μ F \pm 10%	LU01	LB3007526	Balun Coil, 300 Ω \leftrightarrow 75 Ω
CS12	DF1668305	Film, 0.068 μ F \pm 10%	R015	RT0568314	Resistor, 68K Ω \pm 5%, 1/4W
CS13	DF1668205	Film, 0.0068 μ F \pm 10%	R016	RT0568314	Resistor, 68K Ω \pm 5%, 1/4W
CS14	DF1668205	Film, 0.0068 μ F \pm 10%	W001	YC0240010	AC Cord
CS15	DF1668205	Film, 0.0068 μ F \pm 10%	J009		
CS16	DF1668205	Film, 0.0068 μ F \pm 10%	} YT0304005	Terminal, SPK	
		MISCELLANEOUS	J012		
JS01			0517	51100305S	B.H.M. Screw x 6
} YP1000113	YP1000113	Plug	0518	289016004	Bracket
JS10			0519	289016005	Bracket x 2
SS01	SP0406003	Push Switch	0520	289012002	Insulator
R013	RG0503002	Variable Resistor, 50K Ω	PN01	YD2890006	P.W. Board
1606	285310650	Bearing K	ZZ2892106	P.W. Board Assembly	
1611	51640412D	Set Screw C.P.			RESISTORS
1612	54040402N	Spring Washer	RN01	RJ1010102	100 Ω \pm 10%, 2W
1613	53110403E	Hexagon Nut	RN02	RJ1010102	100 Ω \pm 10%, 2W
S009	SP0202010	Push Switch, Power Supply	RN03	RJ1010102	100 Ω \pm 10%, 2W
1032	51100305A	B.H.M. Screw x 2	RN04	RJ1010102	100 Ω \pm 10%, 2W
1031	290416006	Bracket	RN05	GU1056212	5.6K Ω \pm 10%, 1/2W
0513	51100308S	B.H.M. Screw x 16	RN06	GU1056212	5.6K Ω \pm 10%, 1/2W
0514	53110303E	Hexagon Nut x 16	RN07	GU1056212	5.6K Ω \pm 10%, 1/2W
0516	51100306S	B.H.M. Screw x 8	RN08	GU1056212	5.6K Ω \pm 10%, 1/2W
J013	YT0101003	Terminal, Ground	RN09	GU1010012	10 Ω \pm 10%, 1/2W

REF. DESIG.	MARANTZ PART NO.	DESCRIPTION
RN10	GU1010012	10Ω ± 10%, ½W
HN01	HD2000321	DIODES
HN02	HD2000321	1S2471
		1S2471
		MISCELLANEOUS
LN01	LY4048001	Relay
LN02	LY4048001	Relay
JN01		
JN12	YP1000113	Plug
J032	YJ1100012	Jack, Remote Control
0626	289227103	Holder
0628	51380306P	R.H. Tap Screw x 2
9536	138200503	Clamper
PU01	YD2892012 ZZ2892012	P.W. Board, FM De-Emphasis P.W. Board Assembly
CU01	DF6520201	Film Cap., 2000PF ± 5%
CU02	DF6520201	Film Cap., 2000PF ± 5%
SU01	SS0202017	Slide Switch
JU01		
JU10	YP1000113	Plug
L001	LF1120023	Ant Coil, AM
0602	257816052	Bracket K
0607	281927103	Holder
0609	51100310S	B.H.M. Screw x 2
0610	53110301E	Hexagon Nut x 2
0612	51100308S	B.H.M. Screw x 2
0613	53110301E	Hexagon Nut x 2
C001	DK1710301	Ceramic Cap., 0.01μF ± 20%
9836	62031650W	Lug
R014	RC1022512	Resistor, 2.2MΩ ± 10%, ½W
9837	62031650W	Lug
1504	62041760W	Lug
0911	289210701	Sheet
1710	289230201	Dial
S005	SR0602010	Rotary Switch, Amp Mode

REF. DESIG.	MARANTZ PART NO.	DESCRIPTION
L002	LC1332002	Choke Coil, 3.3μH
J039	YL0105004	Plug
J040	YL0105011	Plug, 5P (UL)
C002	DK1710301	Ceramic Cap., 0.01μF ± 20%
C008	ED1080631	Electroly Cap., 1000μF, 63V
J034	YJ0600019	Socket
R002	RA0503014	Variable Resistor, 20KΩ (B)
1425	289216012	Bracket
J035	YJ0700009	Socket, PC Connector 19P
J014	YJ0700006	Jack, SQ Decoder
1405	289210404	Retainer
1406	285110450	Retainer K
1410	51100310S	B.H.M. Screw x 2
1411	59030805P	Fiber Washer x 2
1412	51100305S	B.H.M. Screw x 2
1924	289216051	Bracket K, For CANADA
1928	51100305S	B.H.M. Screw, For CANADA x 2
PW01	YD2892013 ZZ2892013	P.W. Board, Head Phone P.W. Board Assembly
		RESISTORS
RW01	GJ0547001	47Ω ± 5%, 1W
RW02	GJ0547001	47Ω ± 5%, 1W
RW03	GJ0547001	47Ω ± 5%, 1W
RW04	GJ0547001	47Ω ± 5%, 1W
		MISCELLANEOUS
JW01	YJ0100086	Jack, Head Phone
JW02	YJ0100086	Jack, Head Phone
JW03		
JW09	YP1000120	Plug
0918	289212002	Insulator
1203	288627401	Reflector
1214	288627102	Holder
1215	51570305B	P.H. Tap Screw x 2
1217	51480306A	B.H.M. Screw F x 2
J030	YJ0800019	Jack, Meter Lamp
J031	YJ0800019	Jack, Meter Lamp
M002	IN1008007	Lamp, Meter
M003	IN1008007	Lamp, Meter

REF. DESIG.	MARANTZ PART NO.	DESCRIPTION	REF. DESIG.	MARANTZ PART NO.	DESCRIPTION
PF01	YD2892006 ZZ2892006	P.W. Board, Tone Component P.W. Board Assembly	CF13	DF1615205	Film, 1500PF ± 10%, 50V
		RESISTORS All resistors are ±5% and ¼W, unless otherwise indicated.	CF14	DF1615205	Film, 1500PF ± 10%, 50V
RF01	RU0104001	Variable, 100KΩ (B)	CF15	DF1615205	Film, 1500PF ± 10%, 50V
RF02	RU0204001	Variable, 200KΩ (B)	CF16	DF1615205	Film, 1500PF ± 10%, 50V
RF03	RU0204001	Variable, 200KΩ (B)	CF17	DF1633205	Film, 3300PF ± 10%, 50V
RF04	RT0515314	15KΩ	CF18	DF1633205	Film, 3300PF ± 10%, 50V
RF05	RT0515314	15KΩ	CF19	DF1633205	Film, 3300PF ± 10%, 50V
RF06	RT0515314	15KΩ	CF20	DF1633205	Film, 3300PF ± 10%, 50V
RF07	RT0515314	15KΩ	CF21	DD1650001	Ceramic, 50PF ± 10%, 50V
RF08	RT0515314	15KΩ	CF22	DD1650001	Ceramic, 50PF ± 10%, 50V
RF09	RT0515314	15KΩ	CF23	DD1650001	Ceramic, 50PF ± 10%, 50V
RF10	RT0515314	15KΩ	CF24	DD1650001	Ceramic, 50PF ± 10%, 50V
RF11	RT0515314	15KΩ	1026	288310401	Retainer
RF12	RT0527314	27KΩ	1027	51102605A	B.H.M. Screw
RF13	RT0527314	27KΩ			
RF14	RT0527314	27KΩ	PD01	YD2889002 ZZ2892102	P.W. Board, Tone Amp. P.W. Board Assembly
RF15	RT0527314	27KΩ			RESISTORS All resistors are ±5% and ¼W, unless otherwise indicated.
RF16	RT0520314	20KΩ	RD01	RN1022514	2.2MΩ ± 10%, ¼W
RF17	RT0520314	20KΩ	RD02	RN1022514	2.2MΩ ± 10%, ¼W
RF18	RT0520314	20KΩ	RD03	RN1022514	2.2MΩ ± 10%, ¼W
RF19	RT0520314	20KΩ	RD04	RN1022514	2.2MΩ ± 10%, ¼W
RF20	RT0510314	10KΩ	RD05	RT0568314	68KΩ
RF21	RT0510314	10KΩ	RD06	RT0568314	68KΩ
RF22	RT0510314	10KΩ	RD07	RT0568314	68KΩ
RF23	RT0510314	10KΩ	RD08	RT0568314	68KΩ
RF24	RT0510314	10KΩ	RD09	RT0547314	47KΩ
RF25	RT0510314	10KΩ	RD10	RT0547314	47KΩ
RF26	RT0510314	10KΩ	RD11	RT0547314	47KΩ
RF27	RT0510314	10KΩ	RD12	RT0547314	47KΩ
RF28	RT0510314	10KΩ	RD13	RT0510314	10KΩ
RF29	RT0510314	10KΩ	RD14	RT0510314	10KΩ
RF30	RT0510314	10KΩ	RD15	RT0510314	10KΩ
RF31	RT0510314	10KΩ	RD16	RT0510314	10KΩ
RF32	RT0510314	10KΩ	RD17	RT0539114	390Ω
RF33	RT0510314	10KΩ	RD18	RT0539114	390Ω
RF34	RT0510314	10KΩ	RD19	RT0539114	390Ω
RF35	RT0510314	10KΩ	RD20	RT0539114	390Ω
RF36	RT0533414	330KΩ	RD21	RT0510414	100KΩ
RF37	RT0533414	330KΩ	RD22	RT0510414	100KΩ
RF38	RT0533414	330KΩ	RD23	RT0510414	100KΩ
RF39	RT0533414	330KΩ	RD24	RT0510414	100KΩ
RF40	RT0543414	430KΩ			CAPACITORS
RF41	RT0543414	430KΩ	CD01	EV1050256	Electroly, 1μF ± 20%, 25V
RF42	RT0543414	430KΩ	CD02	EV1050256	Electroly, 1μF ± 20%, 25V
RF43	RT0543414	430KΩ	CD03	EV1050256	Electroly, 1μF ± 20%, 25V
CF01	DF1622305	Film, 0.022μF ± 10%, 50V	CD04	EV1050256	Electroly, 1μF ± 20%, 25V
CF02	DF1622305	Film, 0.022μF ± 10%, 50V	CD05	EV3350356	Electroly, 3.3μF ± 20%, 35V
CF03	DF1622305	Film, 0.022μF ± 10%, 50V	CD06	EV3350356	Electroly, 3.3μF ± 20%, 35V
CF04	DF1622305	Film, 0.022μF ± 10%, 50V	CD07	EV3350356	Electroly, 3.3μF ± 20%, 35V
CF05	DF1622305	Film, 0.022μF ± 10%, 50V	CD08	EV3350356	Electroly, 3.3μF ± 20%, 35V
CF06	DF1622305	Film, 0.022μF ± 10%, 50V	CD09	EQ4750161	Electroly, 4.7μF ± 30%, 16V
CF07	DF1622305	Film, 0.022μF ± 10%, 50V	CD10	EQ4750161	Electroly, 4.7μF ± 30%, 16V
CF08	DF1622305	Film, 0.022μF ± 10%, 50V	CD11	EQ4750161	Electroly, 4.7μF ± 30%, 16V
CF09	DF1668205	Film, 6800PF ± 10%, 50V	CD12	EQ4750161	Electroly, 4.7μF ± 30%, 16V
CF10	DF1668205	Film, 6800PF ± 10%, 50V			
CF11	DF1668205	Film, 6800PF ± 10%, 50V			
CF12	DF1668205	Film, 6800PF ± 10%, 50V			

REF. DESIG.	MARANTZ PART NO.	DESCRIPTION
		TRANSISTORS
HD01	HT313452A	2SC1345 (D or E)
HD02	HT313452A	2SC1345 (D or E)
HD03	HT313452A	2SC1345 (D or E)
HD04	HT313452A	2SC1345 (D or E)
HD05	HT107632A	2SA763 (4 or 5)
HD06	HT107632A	2SA763 (4 or 5)
HD07	HT107632A	2SA763 (4 or 5)
HD08	HT107632A	2SA763 (4 or 5)
S001	SR1506004	Rotary Switch, Selector
S002	SR1205005	Rotary Switch, Mode
R012	RT0547014	Resistor, 47Ω ± 5%, ¼W
S003	SR2405001	Rotary Switch, Dolby
R005	RT0510214	Resistor, 1KΩ ± 5%, ¼W
R006	RT0510214	Resistor, 1KΩ ± 5%, ¼W
S004	SR1403001	Rotary Switch, Tape Monitor
R003	RT0510214	Resistor, 1KΩ ± 5%, ¼W
R004	RT0510214	Resistor, 1KΩ ± 5%, ¼W
PC01	YD2892011 ZZ2892011	P.W. Board, FM Cal P.W. Board Assembly
		RESISTORS
RC01	RT0515414	150KΩ ± 5%, ¼W
RC02	RT0515414	150KΩ ± 5%, ¼W
RC03	RT0510314	10KΩ ± 5%, ¼W
RC04	RT0510314	10KΩ ± 5%, ¼W
RC05	RK0203030	Variable, 20KΩ (B)
RC06	RK0203030	Variable, 20KΩ (B)
		MISCELLANEOUS
JC01 ? JC06	YP1000120	Plug
0634	289210907	Shield
0635	281912004	Insulator
3551	62031650W	Lug
3552	62031650W	Lug
1503	138200503	Clamper x 4
2023	138200503	Clamper
W002	YW2892001	Wire Material, For U.S.A.
W003	YX2892001	Wire Material, For U.S.A.
W004	YW2892100	Wire Material, For U.S.A.
W005	YX2892100	Wire Material, For U.S.A.
W010	YW2892003	Wire Material, For CANADA
0411	275905701	Leg, x 4 For U.S.A.
0412	51490410S	P.H.M. Screw F.S. x 4 For U.S.A.

REF. DESIG.	MARANTZ PART NO.	DESCRIPTION
0920	51100306S	B.H.M. Screw x 3
1018	289226251	Pulley K
1023	51100305A	B.H.M. Screw x 2
1221	51570306B	P.H. Tapt Screw x 2
1222	54050300R	T.L. Washer OR x 2
1226	289216011	Bracket
1227	51570406B	P.H. Tape Screw x 2
1229	288610701	Sheet x 2
1231	289210903	Shield
1232	51570305B	P.H. Tape Screw x 2
1233	51570305B	P.H. Tape Screw x 2
1234	289210906	Shield
1235	54020301E	Flat Washer P x 4
1303	289210550	Chassis K
1312	289225901	Bush x 2
1319	51100306S	B.H.M. Screw x 2
1320	51100306S	B.H.M. Screw x 4
1321	51100306S	B.H.M. Screw x 4
1322	51100306S	B.H.M. Screw x 2
1323	51100306S	B.H.M. Screw x 4
1324	51100306S	B.H.M. Screw x 8
1326	51570406B	P.H. Tapt Screw x 4
1328	51570306B	P.H. Tapt Screw x 3
1329	51570306B	P.H. Tapt Screw x 10
1330	51570306B	P.H. Tapt Screw x 4
1332	51570306B	P.H. Tapt Screw x 8
1333	51570306B	P.H. Tapt Screw x 3
1334	51570305B	P.H. Tapt Screw x 2
1335	51570305B	P.H. Tapt Screw x 2
1402	289210901	Shield
1403	285610102	Support x 2
1404	281810107	Support x 3
1409	51100304S	B.H.M. Screw x 5
1419	59030805P	Fiber Washer x 2
1424	289210902	Shield
1433	288810102	Support x 4
1506	281805601	Buffer x 2
1507	54050300R	T.L. Washer OR x 7
1508	288700501	Clamper x 8
1509	62031650W	Lug
1510	54050400R	T.L. Washer x 3
1511	51570305B	P.H. Tapt Screw x 7
1519	51570308B	P.H. Tapt Screw x 2
1528	51100614A	B.H.M. Screw x 4
1529	53110601A	Hexagon Nut x 4
1530	54020801A	Flat Washer P x 4
1531	54040602A	Spring Washer x 4
1532	54020601A	Flat Washer P x 4
1534	282110103	Support x 2
1535	51102605A	B.H.M. Screw x 2
1721	287105302	Cover x 2
1916	289216013	Bracket, For U.S.A.
1935	51570305B	P.H. Tapt Screw x 2
1512	51570305B	P.H. Tapt Screw x 8
1513	51570305B	P.H. Tapt Screw x 4
1514	53110301E	Hexagon Nut
4251	53228059E	Nut x 2
L003	TS6330201	Power Transformer
C004	EA3360109	Electroly Cap., 33μF, 10V
C005	EC2090501	Electroly Cap., 20000μF, 50V
C006	EC2090501	Electroly Cap., 20000μF, 50V

REF. DESIG.	MARANTZ PART NO.	DESCRIPTION	REF. DESIG.	MARANTZ PART NO.	DESCRIPTION
M004	IM1104209	DC Meter, Dolby Signal Meter	2202	289285101	Instructions
M005	IM1104202	DC Meter, FM Tuning Meter	2209	289285601	Schematic Diagram, For U.S.A.
0121	289206451	Case K, For CANADA	2211	289285603	Schematic Diagram, For CANADA
0202	289225701	Lid, For U.S.A.	2216	281885104	Instructions
0203	257711803	Spacer, x 4 For U.S.A.	2217	281885108	Instructions
0204	289205602	Buffer, x 3 For U.S.A.	2221	257785450	Guarantee Card K
0211	289212003	Insulator	2302	289280101	Packing Case, For CANADA
0217	285015401	Knob x 3	2303	289280102	Packing Case, For CANADA
0218	288615403	Knob x 8	2304	289280103	Packing Case, For U.S.A.
0219	290415404	Knob	2305	289280104	Packing Case, For U.S.A.
0220	288615401	Knob x 4	2307	289280301	Partitioner, For U.S.A.
0221	281815403	Knob x 6	2308	289280302	Partitioner, For U.S.A.
0232	288615402	Knob, B.T.L.	2309	289280303	Partitioner, For CANADA x 2
0302	289226501	Indicator, For U.S.A.	2312	901534543	Polyethylen Bag, For U.S.A.
0303	289226502	Indicator, For CANADA	2313	901555045	Polyethylen Bag, For CANADA
0309	51100305S	B.H.M. Screw x 2	2314	901302501	Polyethylen Bag x 2
0311	257886101	Label, For U.S.A., UL Caution	2317	102980401	Sleeve
		For CANADA x 2	2319	273182101	Silicagel x 2
0312	257886102	Label, Do Not Remove, For U.S.A.	2320	281905601	Buffer
0313	257886103	Label, See Marking, For U.S.A.	2322	285125703	Lid
0314	250626506	Indicator, Do not Use as	2323	285386101	Label
0319	282186101	Label, For CANADA	2324	51216059E	Screw x 4
0320	282186102	Label, For CANADA	2331	ZA0200007	EXT Antenna, FM, For U.S.A.
0323	951110102	Label	2402	952281501	Serial NO Card, For U.S.A.
0324	245786104	Label, For CANADA	2403	952301512	Serial NO Card, For CANADA
0334	288686101	Label			
0335	288686102	Label			
0402	52017039J	Bolt x 4			
0404	51100406S	B.H.M. Screw, For U.S.A. x 11			
		For CANADA x 7			
0406	51480406S	B.H.M. Screw F, For U.S.A. x 4			
0416	52010420A	H. Head Bolt, For CANADA x 8			
0417	54080400R	T.L. Washer RR, for CANADA x 8			
0418	51122605S	T.H.M. Screw, For U.S.A. x 4			
0420	289205502	Collar x 2			
0421	54114019I	Washer x 2			
0425	51340306P	F.H. Tap Screw			
0816	56382540G	Eyelet			
1316	51100305S	B.H.M. Screw x 4			
1317	51100304S	B.H.M. Screw x 4			
1413	203912001	Insulator			
1420	289212005	Insulator			
1431	288910904	Shield			
1432	289210905	Shield			
1421	51100305S	B.H.M. Screw			
1515	289200301	Punched Plate x 2			
1516	51100304S	B.H.M. Screw x 4			
1517	51570305B	P.H. Tapt Screw x 4			
1602	285011202	Shaft			
1603	54040402N	Spring Washer			
1702	289226901	Protector			
1704	289226902	Protector			
1708	281912004	Insulator			
1714	51570305B	P.H. Tapt Screw x 2			
1719	51100304S	B.H.M. Screw x 2			
1723	287311801	Spacer			
1725	289226903	Protector			
1911	51100304S	B.H.M. Screw x 4			
1914	289205302	Cover			
2006	289010903	Shield			
2010	289205601	Buffer x 4			
2108	51100305S	B.H.M. Screw x 2			

TECHNICAL SPECIFICATIONS

PREAMPLIFIER SECTION

Dynamic Range	Phono input: 96dB above 1.7 μ V equivalent noise input
Note: Dynamic Range is the ratio in dB of phono overload (110mV) to equivalent input noise (1.7 μ V).	
Input Sensitivity and Impedance	Phono: 1.8mV, 47 Kohms High Level: 180mV, 100 Kohms
Output Level and Impedance	Tape Recorder: 1V into 47 Kohms
Pre-Out Output Impedance	900 ohms
Phono Frequency Response	30Hz to 15KHz \pm 1dB (RIAA)
Noise-Aux	-80dB
Tone Controls	Treble: \pm 10dB at 15KHz Bass: \pm 10dB at 50Hz Mid-Range: \pm 5dB at 700Hz
Filters	Hi Filter: 10KHz, 6dB per octave Low Filter: 100Hz, 6dB per octave
Loudness Compensation	7dB at 100Hz 4dB at 10KHz

AMPLIFIER SECTION

Headphones Output	1V into 8 ohms at rated distortion
Input Sensitivity for MAIN in Front/Rear	1V
Power Output	160 Watts into 8 ohms (40W/channel x 4) 200 Watts into 8 ohms (100W/channel x 2)
Total Harmonic Distortion	At or below rated power, 20Hz to 20KHz Less than 0.15%, typically 0.1% including preamplifier (AUX)
IHF Power Bandwidth	8Hz-70KHz
Frequency Response	\pm 2dB, 5Hz to 70KHz \pm 1dB, 10Hz to 30KHz
Damping Factor	2-channel Mode: 40 at 20Hz 4-channel Mode: 50 at 20Hz

FM SECTION

Quieting Slope	1.9 μ V for 30dB, 5 μ V for 55dB 10 μ V for 60dB, 50 μ V for 70dB
Ultimate Quieting	50 μ V for 70dB
Selectivity	Alternate channel, better than 75dB
Capture Ratio	1.5dB
Muting Threshold	Muting threshold variable from 8 μ V to 35 μ V
Stereo Separation	40dB at 1KHz, 27dB at 15KHz
Total Harmonic Distortion	Stereo: Less than 0.3% Mono: Less than 0.2%
Frequency Response	\pm 1dB, 30Hz to 15KHz
Total Spurious Rejection	Better than 90dB
Image Rejection	Better than 90dB
AM Suppression	Better than 60dB
IF Rejection	Better than 100dB
Antenna Impedance	300 ohm Balanced, 75 ohm unbalanced
Quadrantal Output	300mV, 15 Kohms for \pm 75KHz Dev.

AM SECTION

AM Sensitivity	Better than 40 μ V
----------------	------------------------

Selectivity Adjacent channel, 1000KHz, better than 30dB
 AM Bandwidth (-6dB) 7KHz
 Image Rejection 1400KHz, better than 70dB

GENERAL

Power Requirements 120V AC, 50 to 60Hz
 Power Consumption – at rated power output, all channels 400 Watts
 – idling (no signal) 45 Watts
 Dimensions – Panel Width 19-19/64" – 490mm
 – Panel Height 5-3/4" – 146mm
 – Depth 15-13/64" – 386mm
 Weight – Unit alone 51.6 lbs – 23.5Kg
 – Packed for Shipment 62.7 lbs – 28.5Kg

* These specifications and exterior designs may be changed for improvement without advance notice.