



TABLE OF CONTENTS

Section	Title	Page
1.	P.W. BOARDS	1
2.	TEST EQUIPMENT REQUIRED FOR SERVICING	2
3.	AM ALIGNMENT PROCEDURES	2
3.1	AM IF Alignment	2
3.2	AM Frequency Range and Tracking Alignment	2
3.3	AM Signal Strength Display Adjustment	2
4.	FM ALIGNMENT PROCEDURES	2
4.1	IF Frequency Range and Tracking Alignment	2
4.2	Stereo Separation Alignment	3
4.3	Muting Circuit Alignment	3
4.4	Dolby FM Tape Output Setting	3
5.	AUDIO ADJUSTMENT	3
6.	SCOPE DISPLAY ADJUSTMENT	4
6.1	AM Tuning Display Adjustment	4
6.2	FM Tuning Display Adjustment	4
6.3	FM Multipath Display Adjustment	4
7.	VOLTAGE CONVERSION FOR EUROPEAN MODEL	4
8.	DIAGRAMS	6
8.1	Block Diagram	6
8.2	Connection Diagram - U.S.A. & Canada	8
8.3	Connection Diagram - Europe	10
9.	SCHEMATIC DIAGRAMS AND COMPONENTS LOCATIONS	12
9.1	FM Front End Circuit Board - P100	12
9.2	AM Tuner, FM IF & MPX Stereo Decoder Circuit Board - P200	13
9.3	FM Noise Amp Circuit Board - PB00	16
9.4	FM Buffer Amp Circuit Board - PC01	16
9.5	Phono Amp & Selector Switch Circuit Board - P400	17
9.6	Power Supply Circuit Board - P800 - U.S.A. & Canada	18
9.7	Power Supply Circuit Board - P800 - Europe	19
9.8	Main Amp Circuit Board - P700	20
9.9	Pre & Tone Amp Circuit Board - PE01	22
9.10	Dolby NR Socket Circuit Board - PK01	24
9.11	Audio Muting Circuit Board - PN01	24
9.12	Buffer Amp for Scope Input - Circuit Board - PD01	24
9.13	Tape Copy, Tape Monitor & Scope Display Switches Circuit Board - PS01	25
9.14	Dubbing In & Out Jacks Circuit Board - PU01	25
9.15	Filter Amp Circuit Board - PT01	26
9.16	Speaker System Switches & Attenuator Circuit Board - PW01	27
9.17	Function Indicator Circuit Board - PY01	27
9.18	Dial Lamp Circuit Board - PZ01	27
9.19	Tape Monitor Switches Connection Circuit Board - PR01	28
9.20	Scope Amp Circuit Board - P900	28
9.21	Power Transistor Connection Circuit Board - PM01	28
9.22	Peak Indicator & Soft Start Circuit Board - PX01	29
10.	MAJOR COMPONENT LOCATIONS	30
10.1	Cabinet - Front View - U.S.A. & Canada	30
10.2	Chassis - Top View - U.S.A. & Canada	30
10.3	Cabinet - Rear View - U.S.A. & Canada	31
10.4	Chassis - Bottom View - U.S.A. & Canada	31

11. EXPLODED VIEWS	
11.1 Front Panel Exploded View	32
11.2 Chassis Exploded View	32
11.3 Rear Panel Exploded View - U.S.A. & Canada	34
11.4 Rear Panel Exploded View - Europe	36
11.5 Packing Material Exploded View	37
12. PARTS LIST	38
13. TECHNICAL SPECIFICATIONS	54
14. SCHEMATIC DIAGRAMS	56

INTRODUCTION

This service manual was prepared for use by Authorized Warranty Stations and contains service information for Marantz Model 2500 Stereophonic Receiver.

Servicing information and voltage data included in this manual are intended for use by the knowledgeable and experienced technician only. All instructions should be read carefully. No attempt should be made to proceed without a good understanding of the operation of the receiver.

The parts list furnishes information by which replacement parts may be ordered from the Marantz Company. A simple description is included for parts which can usually be obtained through local suppliers.

1. P.W. BOARDS

As can be seen from the circuit diagram the chassis of Model 2500 consists of the following units. Each unit mounted on a printed circuit board is described within the square enclosed by a bold dotted line on the circuit diagram.

- 1. FM Front End mounted on P.W. Board P100
- 2. AM Tuner, FM IF & MPX Stereo Decoder mounted on P.W. Board P200

- 3. FM Noise Amp mounted on P.W. Board PB00
- 4. FM Buffer Amp mounted on P.W. Board PC01
- 5. Phono Amp & Selector Switch mounted on P.W. Board P400
- 6. Main Amp mounted on P.W. Board P700
- 7. Power Supply mounted on P.W. Board P800
- 8. Pre & Tone Amp mounted on P.W. Board PE01
- 9. Dolby NR Socket mounted on P.W. Board PK01
- 10. Audio Muting mounted on P.W. Board PN01
- 11. Buffer Amp for Scope Input mounted on P.W. Board PD01
- 12. Tape Copy, Tape Monitor & Scope Display Switches mounted on P.W. Board PS01
- 13. Filter Amp mounted on P.W. Board PT01
- 14. Dubbing In & Out Jacks mounted on P.W. Board PU01
- 15. Speaker System Switches & Attenuator mounted on P.W. Board PW01
- 16. Function Indicator mounted on P.W. Board PY01
- 17. Dial Lamp mounted on P.W. Board PZ01
- 18. Tape Monitor Switches Connection mounted on P.W. Board PR01
- 19. Scope Amp mounted on P.W. Board P900
- 20. Peak Indicator & Soft Start mounted on P.W. Board PX01
- 21. Power Transistor Connection mounted on P.W. Board PM01

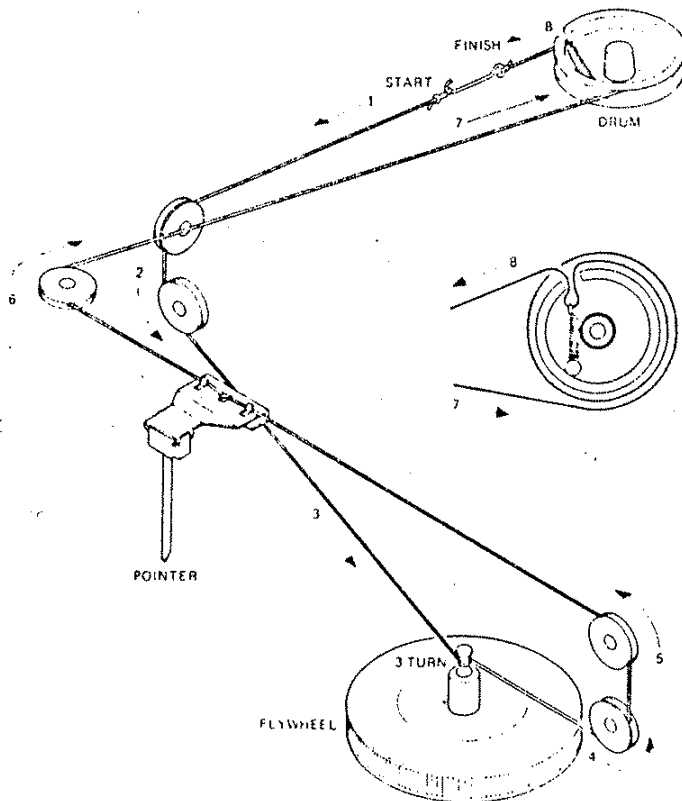

Figure 1. Dial Stringing

2. TEST EQUIPMENT REQUIRED FOR SERVICING

This table lists the test equipment required for servicing the Model 2500 Receiver.

Item	Manufacturer and Model No.	Use
AM Signal Generator		Signal source for AM alignment
Test Loop		Use with AM Signal Generator
FM Signal Generator MPX Signal Generator	Sound Technology Model 1000A	Signal source for FM alignment Stereo separation alignment and trouble shooting
Distortion Analyzer Audio Oscillator AC VTVM	Sound Technology Model 1700A	Distortion measurements Sinewave and squarewave signal source Voltage measurements (AC)
Oscilloscope	Tektronix Model T932 Philips Model 3232	Waveform analysis and trouble shooting and ASO alignment
Frequency Counter	Fluke Model 1900A	MPX Oscillator adjustment (VCO)
Circuit Tester		Trouble shooting
DC VTVM	Fluke Model 8000 "Digital" Simpson Model 313, Triplet Model 801	Voltage measurements (DC)
AC Wattmeter	Simpson Model 1379	Monitors primary power to amplifier
AC Ammeter	Commercial Grade (1-30A)	Monitors amplifier output under short circuit condition
Line Voltmeter	Simpson Model 1359	Monitors potential of primary power to amplifier
Variable Autotransformer	Superior Electronic Co., Powerstat Model 116B-10A	Adjusts level of primary power to amplifier
Shorting Plug	Use phono plug with 600-ohm across center pin and shell	Shorts amplifier input to eliminate noise pickup
Output Load (8 ohms, 0.5%, 300 W)	Commercial Grade	Provides 8-ohm load for amplifier output termination
Output Load (4 ohms, 0.5%, 500 W)	Commercial Grade	Provides 4-ohm load for amplifier output termination

3. AM ALIGNMENT PROCEDURES

3.1 AM IF ALIGNMENT

1. Connect a sweep generator to the J229 and an alignment scope to the test point B.
2. Rotate each core of IF transformers L153 and L154 for maximum height and flat top symmetrical response.

3.2 AM FREQUENCY RANGE AND TRACKING ALIGNMENT

1. Set AM signal generator to 515 kHz. Turn the tuning capacitor fully closed (place the tuning pointer at the low end) and adjust the oscillator coil L152 for maximum audio output.
2. Set the signal generator to 1650 kHz. Place the tuning pointer in the high frequency end and adjust the oscillator trimmer on the oscillator tuning capacitor for maximum audio output.
3. Repeat steps 1 and 2 until no further adjustment is necessary.
4. Set the generator to 600 kHz and tune the receiver to the same frequency and adjust a slug core of AM ferrite-rod antenna L002 and RF coil L151 for maximum output.

5. Set the generator to 1400 kHz and tune the receiver to the same frequency and adjust both trimming capacitors of antenna and RF tuned circuit for maximum output.
6. Repeat steps 4 and 5 until no further adjustment is necessary.

NOTE: During tracking alignment reduce the signal generator output as necessary to avoid AGC action.

3.3 AM SIGNAL STRENGTH DISPLAY ADJUSTMENT

Set an AM signal generator to 1000 kHz at 100 dB/m, and adjust R163 so that the spot may meet upper mark.

4. FM ALIGNMENT PROCEDURES

4.1 FM FREQUENCY RANGE AND TRACKING ALIGNMENT

1. Connect an FM signal generator to the FM ANTENNA terminals and an oscilloscope and an audio distortion analyzer to the TAPE MONITOR OUT jacks on the rear panel.
2. Set the signal generator to 87.4 MHz and provide about 3 to 5 μ V. Place the tuning pointer at the low frequency end by rotating the tuning knob and adjust the core of

oscillator coil L106 to obtain maximum audio output.

3. Set the signal generator to 109 MHz and provide about 3 to 5 μ V output. Rotate the tuning knob and place the tuning pointer at the high frequency end and adjust the trimming capacitor C123 for maximum output.
4. Repeat steps 2 and 3 until no further adjustment is necessary.
5. Set the signal generator to 90 MHz and tune the receiver to the same frequency. Decrease signal generator output until the audio output level decreases with the decreasing generator output. Adjust the antenna coil L101, RF coils L102, L103 and L104 and IF transformer L105 for minimum audio distortion.
6. Set the signal generator to 106 MHz and tune the receiver to the same frequency. Adjust the trimming capacitors CF01, CF02, CF03 and CF04 for minimum distortion.
7. Repeat steps 5 and 6 until no further adjustment is necessary.
8. Connect a VTVM (at DC 1 V range) across the J204 and J205. Adjust the secondary core (upper) of discriminator transformer L201 so that the VTVM indicates null reading (zero reading) at no signal. Set the FM signal generator to 98 MHz and increase its output level 1 μ V and tune the receiver to the same frequency so that the VTVM gives null reading. Adjust the primary core (lower) of L201 for minimum distortion. (Scope display can, of course, be used as tuning indicator instead of the VTVM, if the scope unit has been correctly adjusted as instructed in the "Scope Display Adjustment".)
9. Set the signal generator to 98 MHz at 100 μ V, and adjust R278 so that the signal strength indicator spot just reaches upper mark.

4.2 STEREO SEPARATION ALIGNMENT

1. Set the FM signal generator to provide 1 μ V at 98 MHz. Tune the receiver to the same frequency so that the center tuning indicator spot indicates its center.
2. Turn the signal generator modulation off (with the pilot signal turned off), connect a frequency counter to test point J238, and adjust R310 so that the frequency counter may precisely read 19 kHz.
3. Modulate the signal generator with stereo composite signal consisting only of subchannel signal (of course a pilot signal must be included).
4. Adjust the trimming resistor R319 for maximum and same separation in both channels.

4.3 MUTING CIRCUIT ALIGNMENT

1. Set the FM signal generator to provide 6 μ V at 98 MHz and tune the receiver to the same frequency correctly.
2. Depress the FM MUTING pushswitch. Set R001 to MIN position (counterclockwise). Adjust R330 until the muting circuit is activated to produce output for exactly 6 μ V input.
3. In turn increase the FM signal generator output up to 50 μ V.
4. Set R001 to MAX position (clockwise). Adjust R347 until the muting circuit is activated to produce output for exactly 50 μ V input.
5. Turn R001 from MIN to MAX to assure the muting threshold level can change in the range of 6 to 50 μ V.

6. Adjust R001 until the muting threshold level is 12.5 V. Then, increase the FM signal generator output up to 1 μ V and shift its frequency up and down. Note both up- and down-shifted frequencies at which undesirable audio side responses are muted out. Adjust R280 until the muting circuit is activated when the oscilloscope trace deflects 10 to 20 mm.

4.4 DOLBY FM TAPE OUTPUT SETTING

1. Set the modulation of FM signal generator to 400 Hz, 50% (± 37.5 kHz Dev.).
2. Set the signal generator to provide 1 μ V at 98 MHz. Tune the receiver to the same frequency so that the center tuning meter pointer indicates its center.
3. Set the SELECTOR switch to the FM 25 μ S position. Set the trimming resistors RC01 and RC02 so that the output of the TAPE MONITOR OUT jacks R and L become 580 mV at VTVM.

5. AUDIO ADJUSTMENT

1. Voltage adjustment
Connect a DC voltmeter across the pins 4 and 3 on J805. Adjust the trimming resistor R819 until the DC voltmeter reads 32 V.
2. Main Amplifier DC off-set alignment
Connect a DC voltmeter with 0.5 or 1 V range between the speaker terminals and adjust the trimming resistor R760 for "zero" DC output on the meter. Repeat the same procedure for the other channel.

NOTE: During this alignment no load should be connected to the speaker terminals.

3. Idle current adjustment
Connect a DC voltmeter (in 50 mV range) across TP1 and TP2 on JX01. Adjust R716 on the P.W. board on the left side of the tunnel heatsink until the voltmeter reads 25 mV (32 mA). In turn, connect the voltmeter across TP3 and TP4 on JX02 and similarly, adjust R716 on the P.W. board on the right side of the tunnel heatsink until the voltmeter reads 25 mV (32 mA).
4. Check DC off-set voltage aligned in the procedure 3 and if any DC output is observed on the DC voltmeter, adjust the R760 again for "zero" output.

CAUTION: CONTINUOUS POWER OUTPUT TESTS.

Continuous sine wave tests at high audio power levels impose a maximum loading condition for the power supply, particularly when testing with 4 ohm output loads, and far exceeds power supply loading encountered with program materials. A primary line fuse has been selected for the Model 2500 which will open if the following 4 ohm testing periods are exceeded:

- A. At rated power of 330 watts per channel.
Testing period- 45 minutes max.
- B. At power levels above 330 watts per channel.
Individual tests- 1 minute max.

6. SCOPE DISPLAY ADJUSTMENT

1. Set the SELECTOR switch to the AUX position.
2. Set the SCOPE LEVEL and VOLUME controls to the FCCW position.
3. Depress the SCOPE DISPLAY ON and AUDIO push-switches in.
4. Adjust the CENTERING controls until the spot comes in the center of the small circle.
5. Adjust the BRIGHT control (R002) on the rear panel until the brightness becomes dark a little.
6. Adjust the FOCUS control so that the spot may become smaller and circular.
7. Turn the SCOPE LEVEL control to the FCW.
8. Connect a 150 mV, 1 kHz signal to the AUX INPUTS R jack and adjust R928 (H. GAIN) until the horizontal deflection is around 3 cm.
9. In turn, connect the same signal to the L jack and similarly, adjust R927 (V. GAIN) until the vertical deflection is around 3 cm.
10. Set the CENTERING control to the 12-o'clock position and adjust R925 (H. CENTER) until the spot comes in the horizontal deflection center.
11. Similarly, adjust R926 (V. CENTER) until the spot comes in the vertical deflection center.

6.1 AM TUNING DISPLAY ADJUSTMENT

1. Depress the SCOPE DISPLAY ON and TUNING push switches. Set the SELECTOR switch to the AM position.
2. Adjust R931 until the spot comes in the center below the base line without tuning into a station.

6.2 FM TUNING DISPLAY ADJUSTMENT

1. Depress the scope DISPLAY ON and TUNING push switches. Set the SELECTOR switch to the FM position.
2. Connect FM signal input of 100 μ V (98 MHz, 400 Hz 30% mod.) to the FM ANTENNA terminals and adjust R278 so that the spot does not frame out.

6.3 FM MULTIPATH DISPLAY ADJUSTMENT

1. Adjust R280 to obtain full deflection of the trace within both side marks, applying FM signal (1 μ V, 400 Hz, 100% mod.) to the FM ANTENNA terminals.

7. VOLTAGE CONVERSION FOR EUROPEAN MODEL

The European version of the Model 2500 is equipped with a universal power transformer that may be adjusted to operate at 110 V, 120 V, 220 V, or 240 V AC at 50 to 60 Hz. To convert the unit to a different power source voltage, reposition conversion plug as shown in Figure 1.

CAUTION: DISCONNECT POWER SUPPLY CORD FROM AC OUTLET BEFORE CONVERTING VOLTAGE.

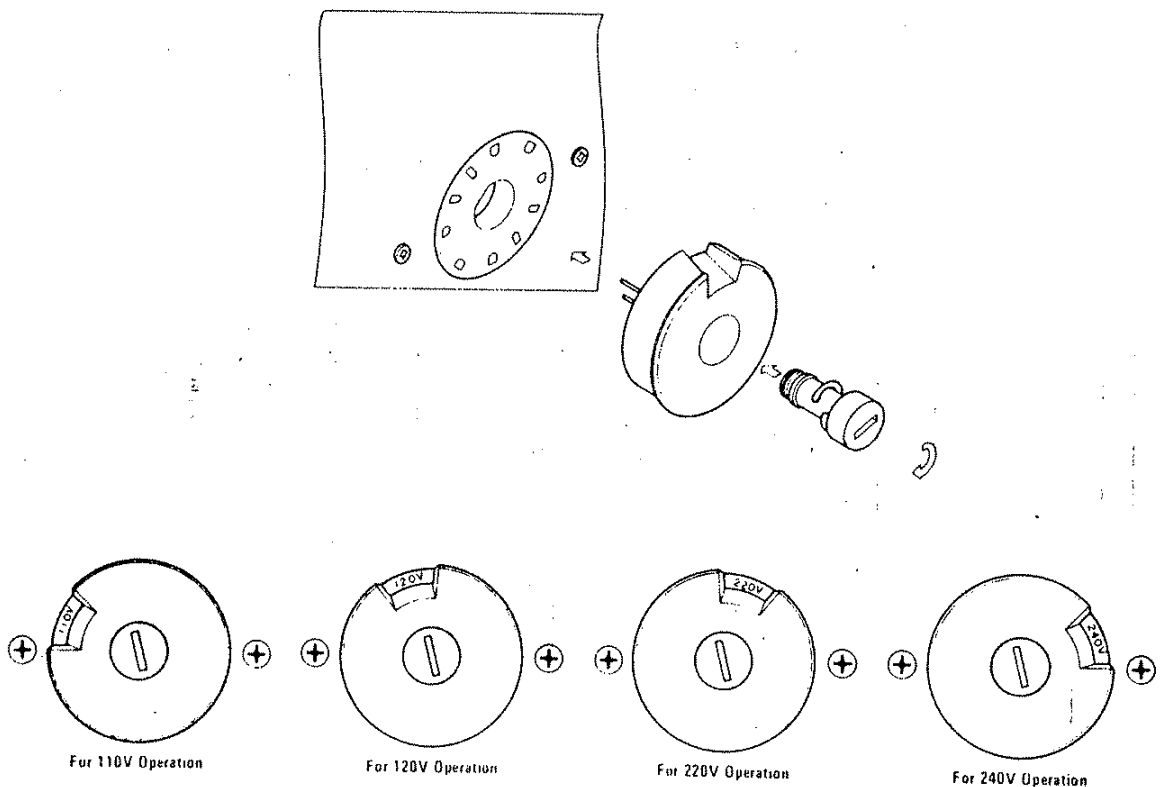

Figure 2. Voltage Conversion Chart

FTZ REGULATION

Instruction for the use in the range other than specified in FTZ codes.

Achtung für die Leute, die in dem Gebiet wohnen, wo die FTZ-Bestimmungen vorherrschend sind.

Sollte das Gerät auch für Frequenzen ausserhalb des in den FTZ-Bestimmungen angegebenen Bereiches empfangbereit sein, bitten wir, den Bereich durch Nachstellen des Kernes in der Oszillatortspule (in der Abbildung mit "FTZ" gekennzeichnet) so zu korrigieren, dass er den Bestimmungen entspricht.



8. DIAGRAM

8.1 BLOCK DI

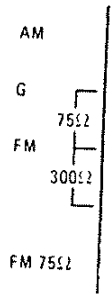

PHONO 1
PHONO 2
AUX

IN
TAPE MONITOR
OUT

IN
TAPE MONITOR
OUT

*The other audio

9. SCHEMATIC DIAGRAMS AND COMPONENTS LOCATIONS

9.1 FM FRONT END CIRCUIT BOARD - P100

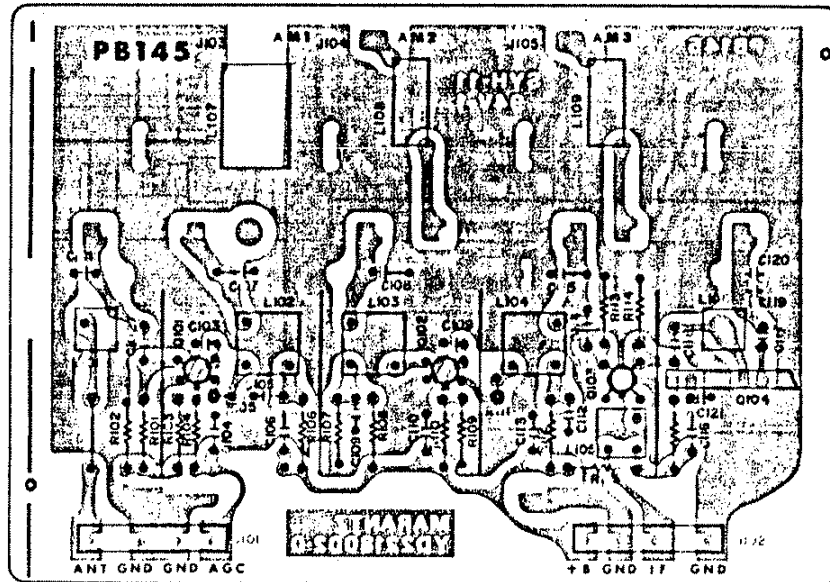
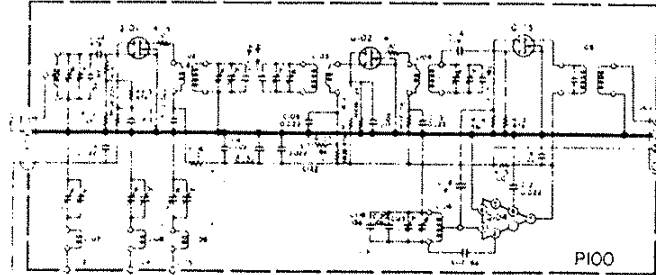

9.5 PHONO AMP & SELECTOR SWITCH CIRCUIT BOARD - P400

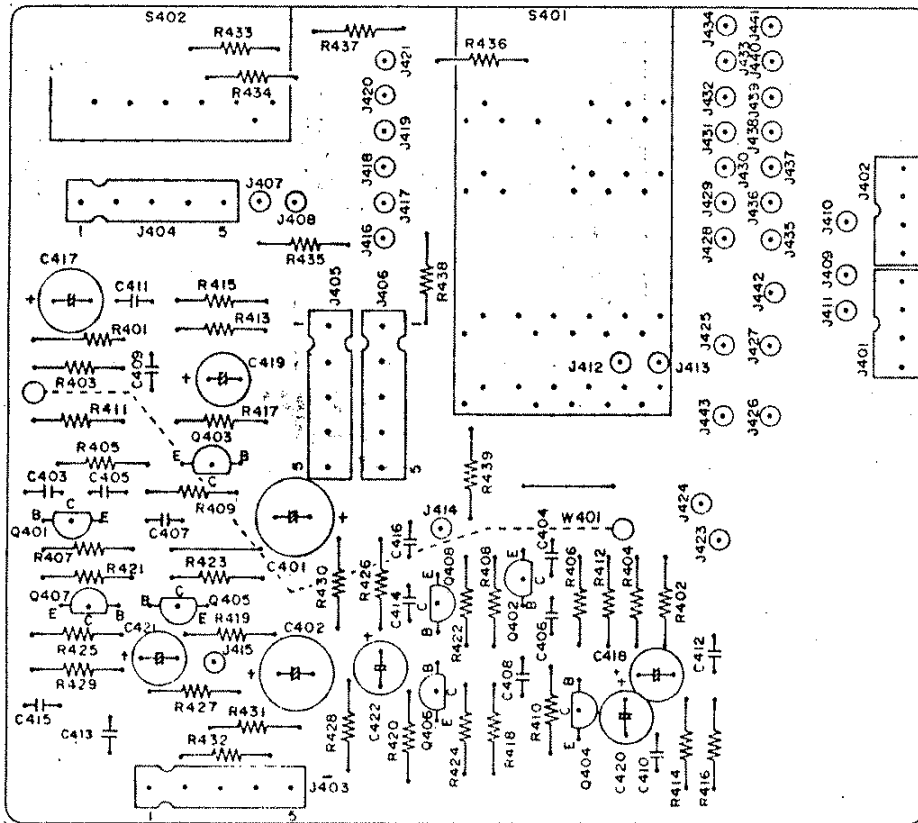
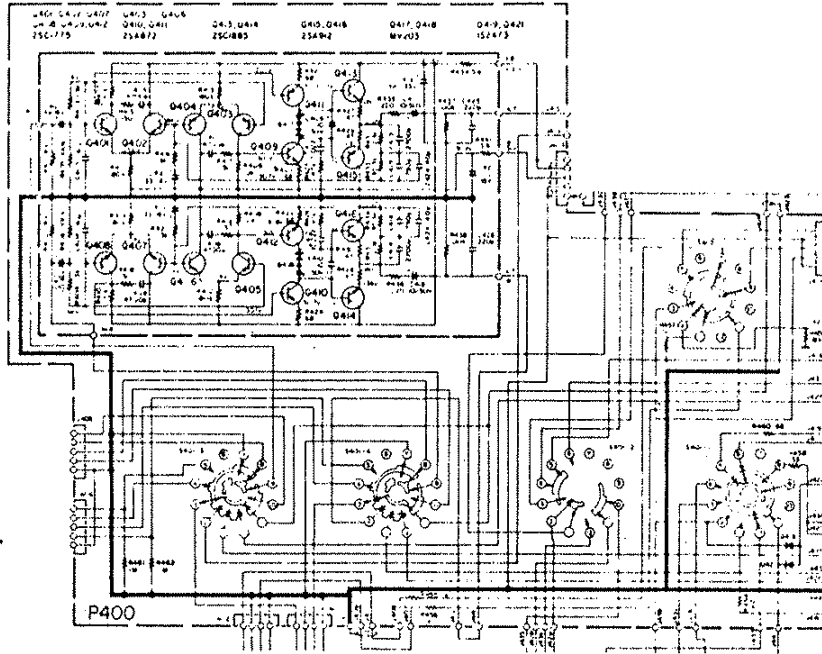

9.6 POWER SUPPLY CIRCUIT BOARD - P800 - U.S.A. & CANADA

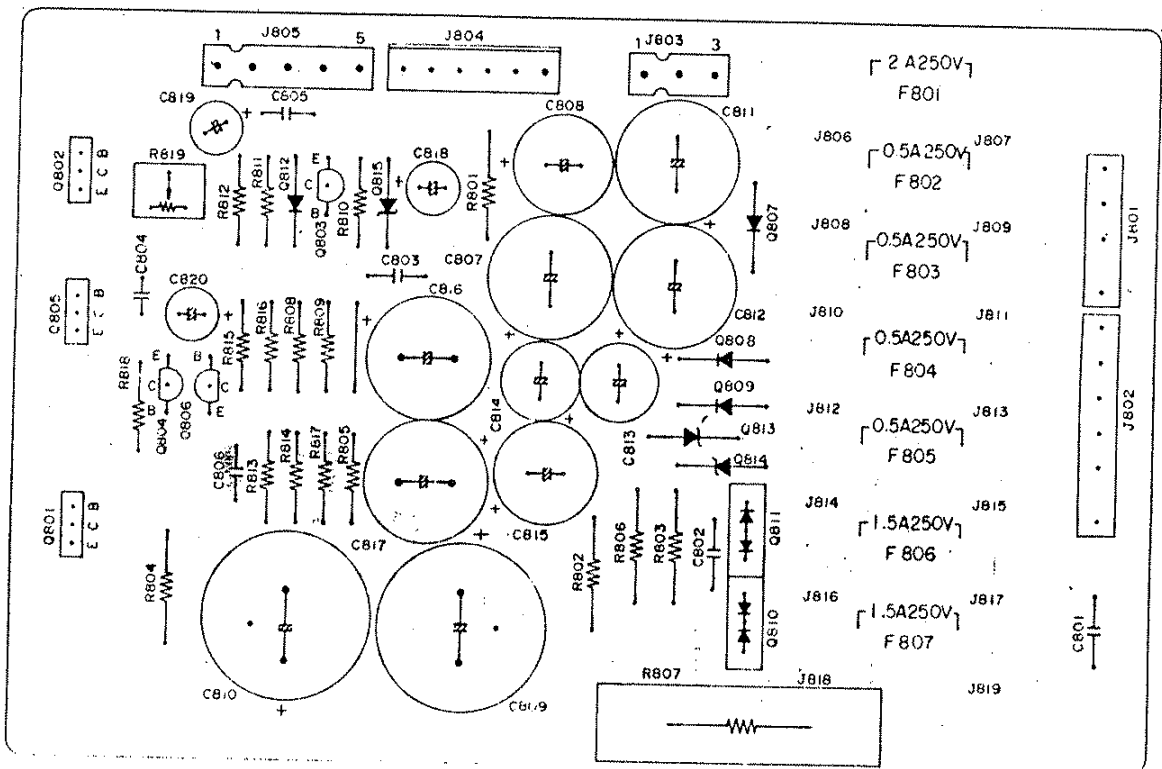
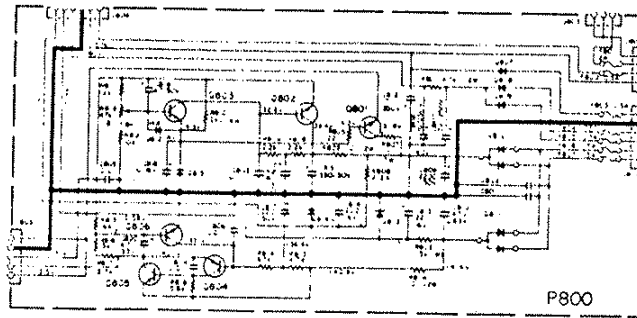

9.7 POWER SUPPLY CIRCUIT BOARD - P800 - EUROPE

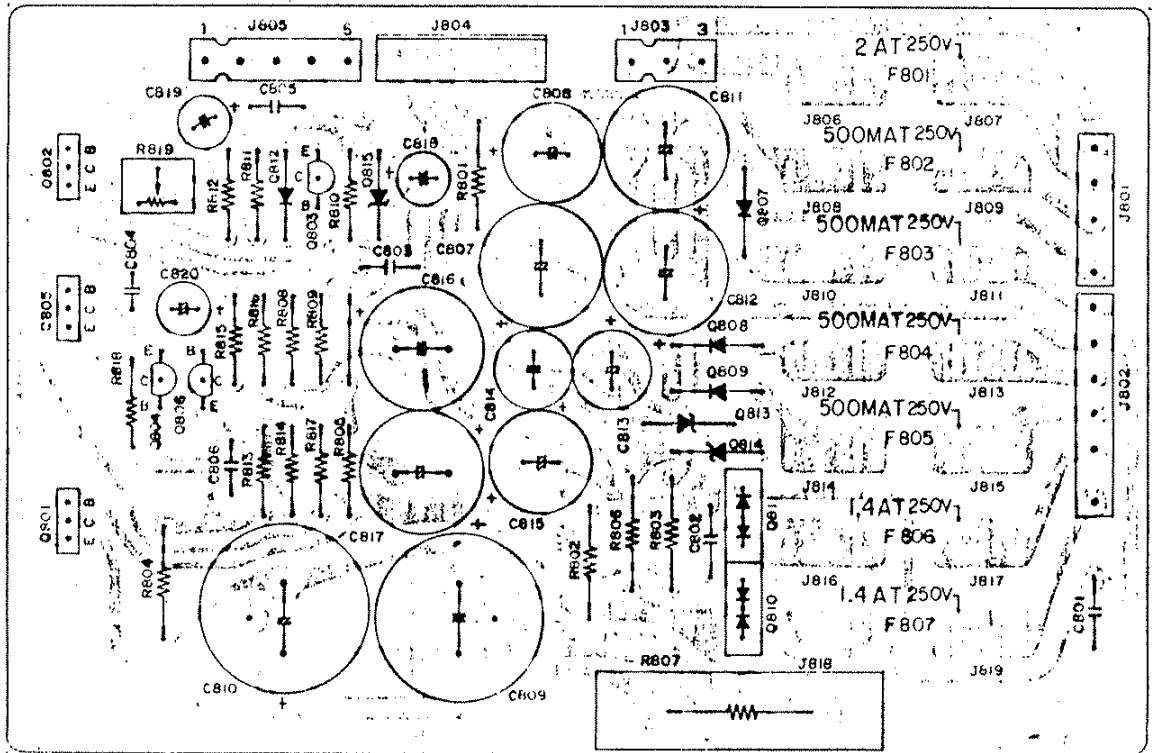

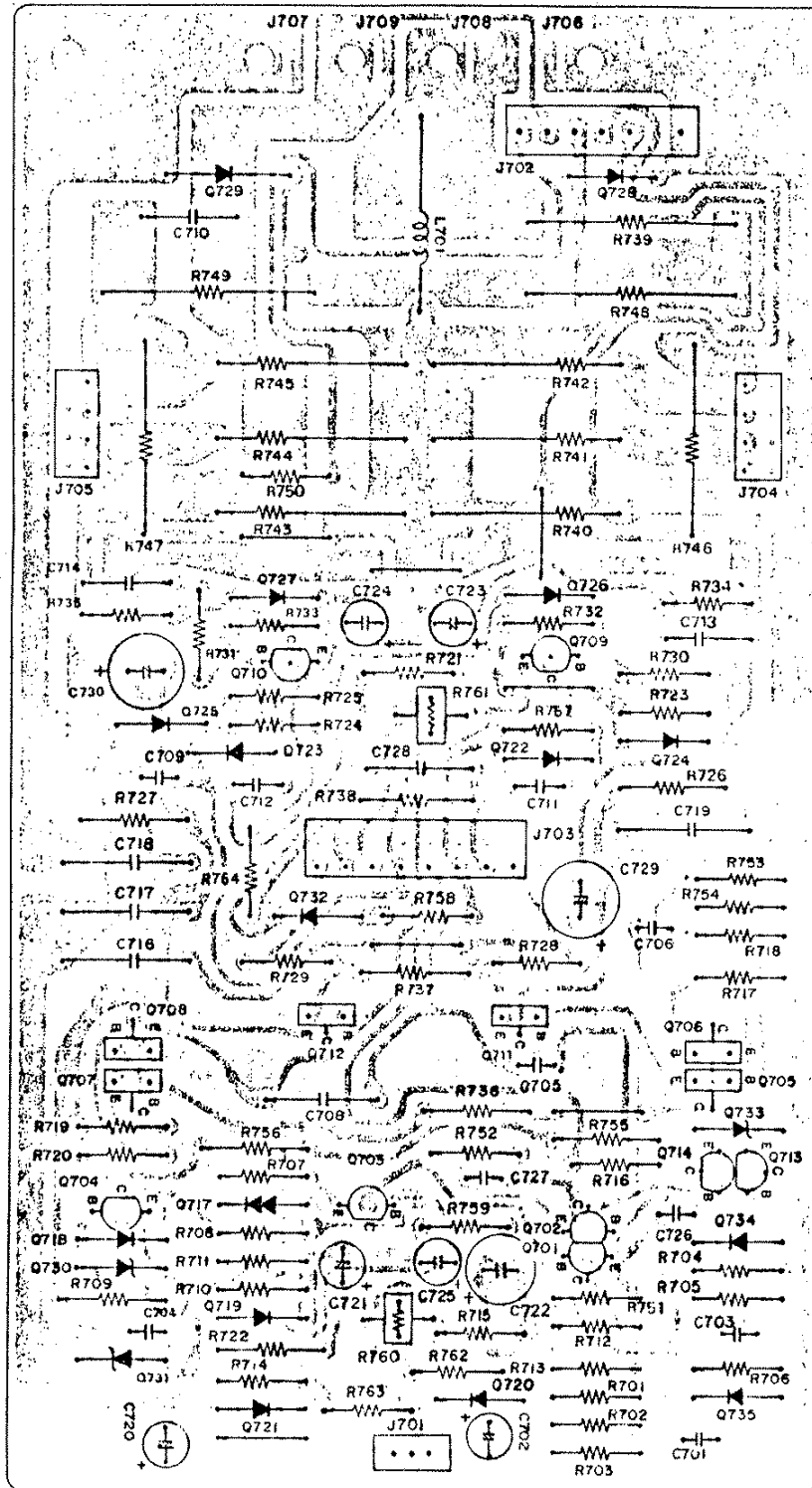

9.10 DOLBY NR SOCKET CIRCUIT BOARD - PK01

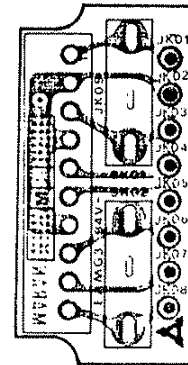
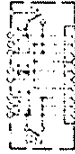

9.11 AUDIO MUTING CIRCUIT BOARD - PNO1

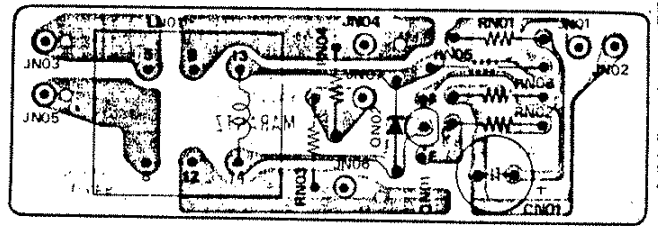
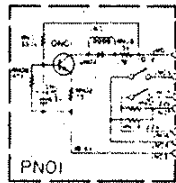

9.12 BUFFER AMP FOR SCOPE INPUT - CIRCUIT BOARD - PD01

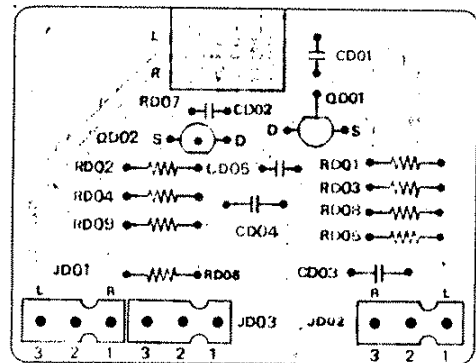
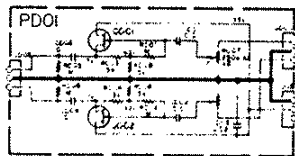

9.16 SPEAKER SYSTEM SWITCHES & ATTENUATOR CIRCUIT BOARD - PW01

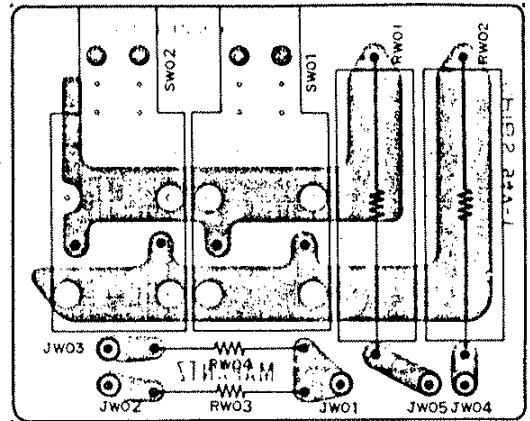

9.17 FUNCTION INDICATOR CIRCUIT BOARD - PY01

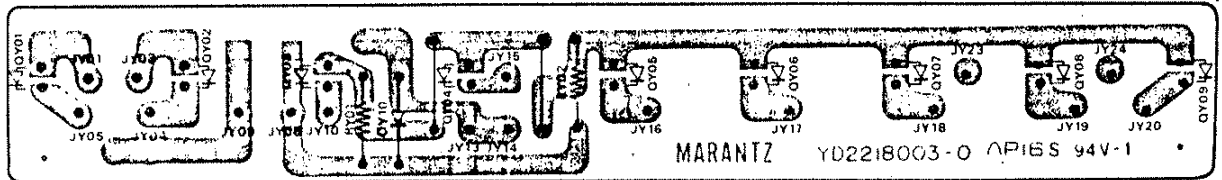

9.18 DIAL LAMP CIRCUIT BOARD - PZ01

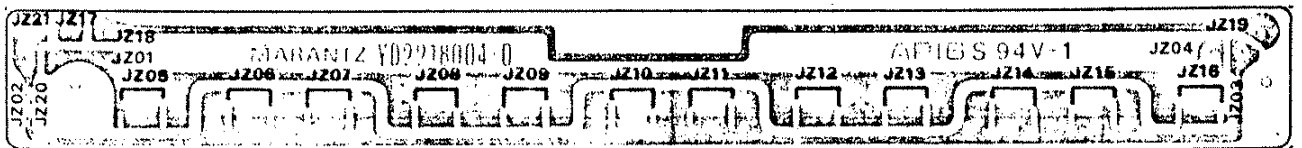
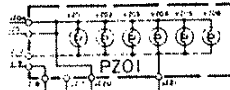

9.19 TAPE MONITOR SWITCHES CONNECTION CIRCUIT BOARD - PR01

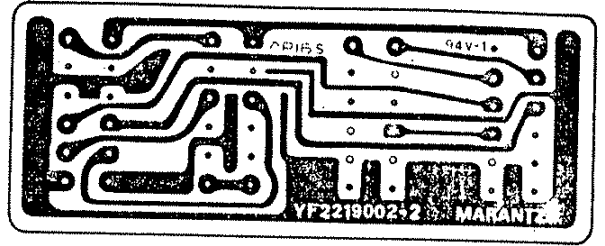
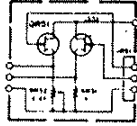

9.20 SCOPE AMP CIRCUIT BOARD - P900

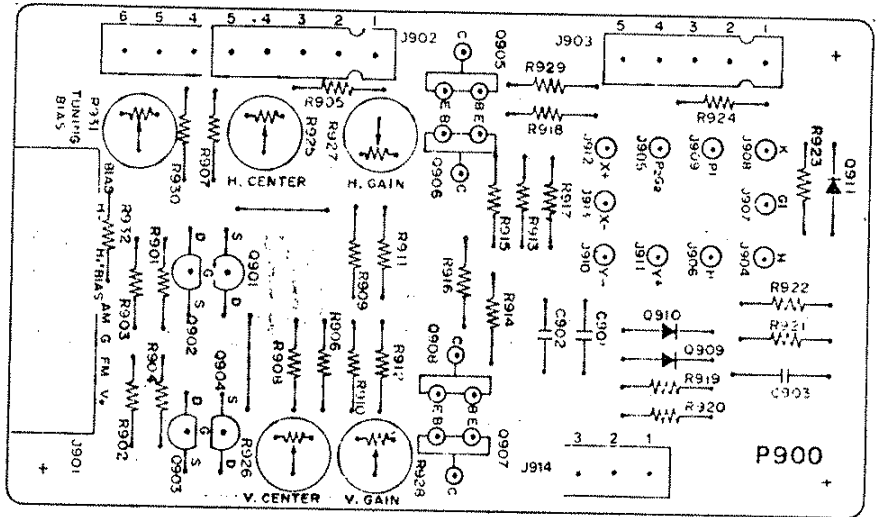
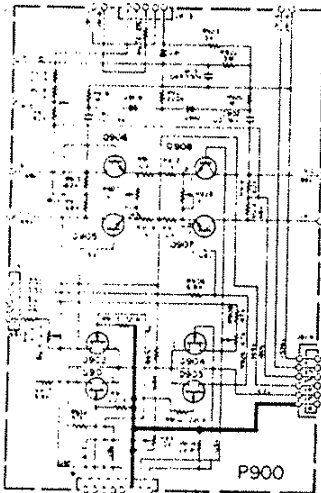

9.21 POWER TRANSISTOR CONNECTION CIRCUIT BOARD - PM01

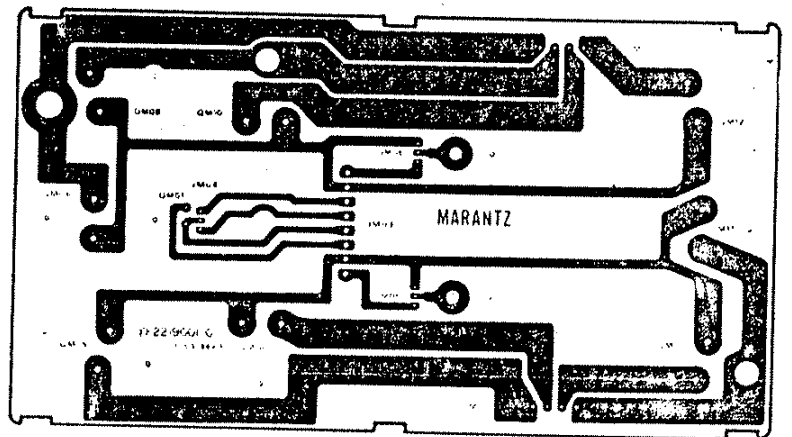
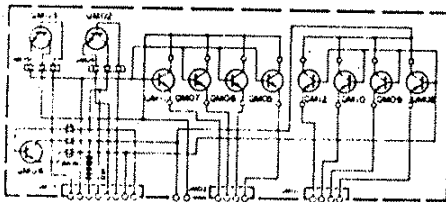

9.22 PEAK INDICATOR & SOFT START CIRCUIT BOARD - PX01

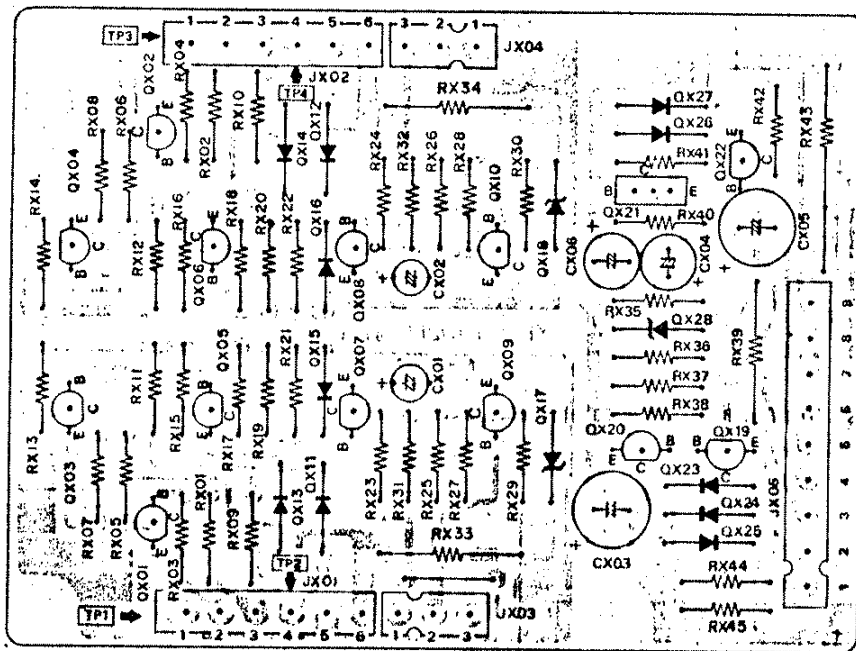
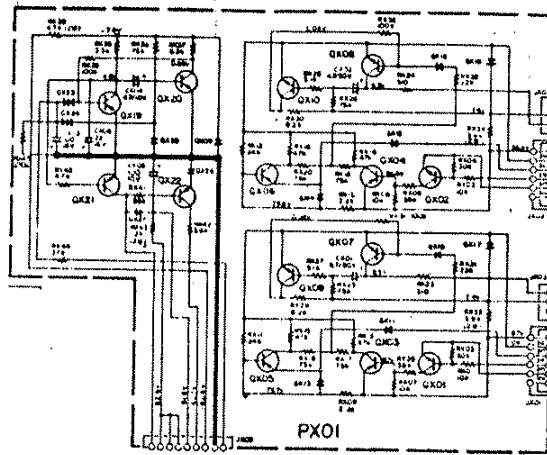

10. MAJOR COMPONENT LOCATIONS

10.1 CABINET - FRONT VIEW - U.S.A. & CANADA

COMMAD 2-A 50 5-17-1964 1001 4-201

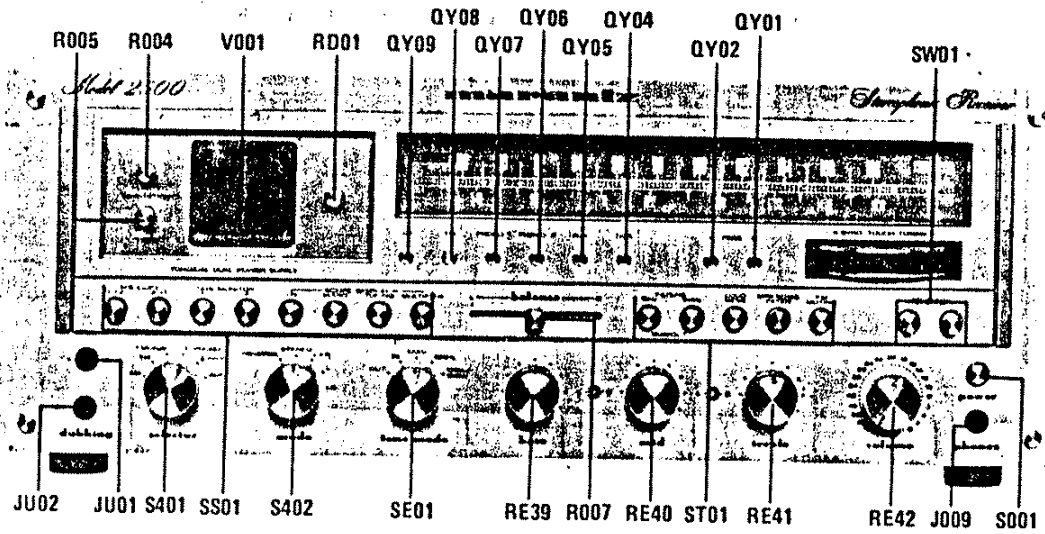

10.2 CHASSIS - TOP VIEW - U.S.A. & CANADA

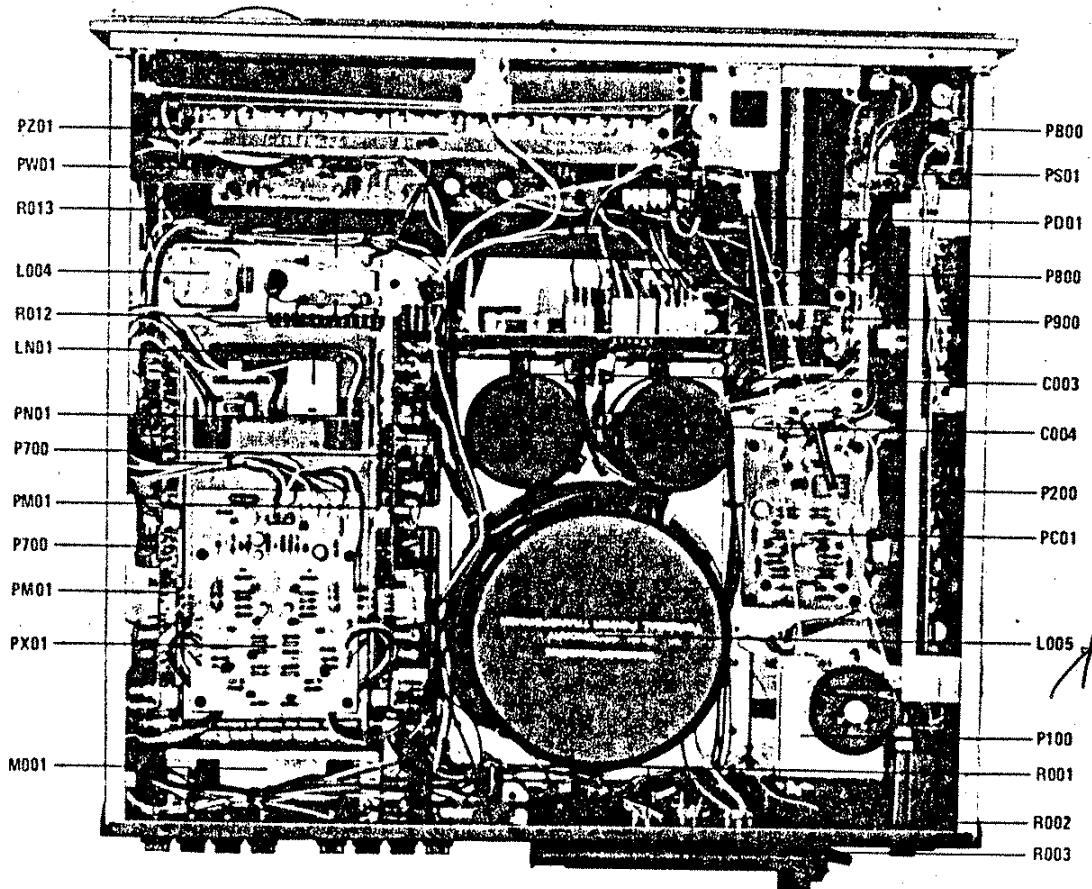

10.3 CABINET - REAR VIEW - U.S.A. & CANADA

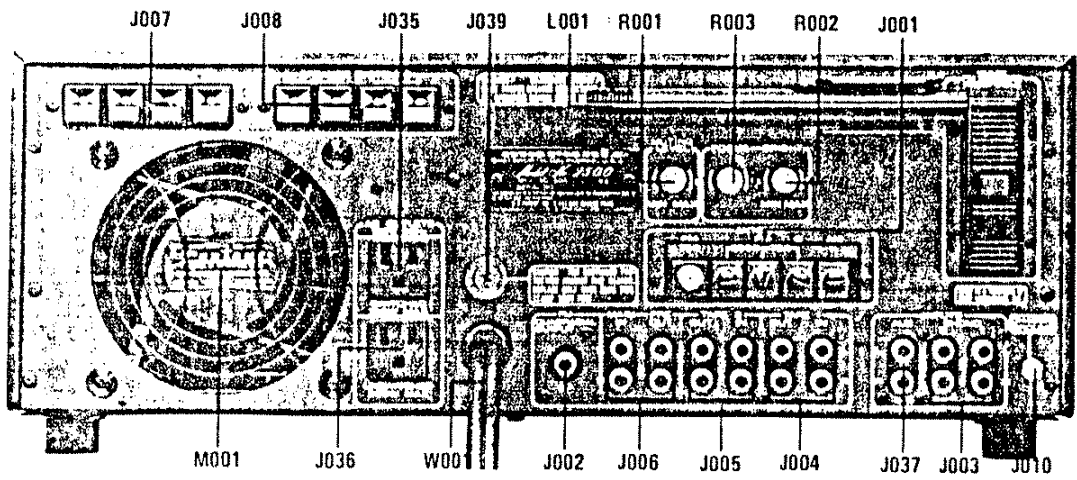

10.4 CHASSIS - BOTTOM VIEW - U.S.A. & CANADA

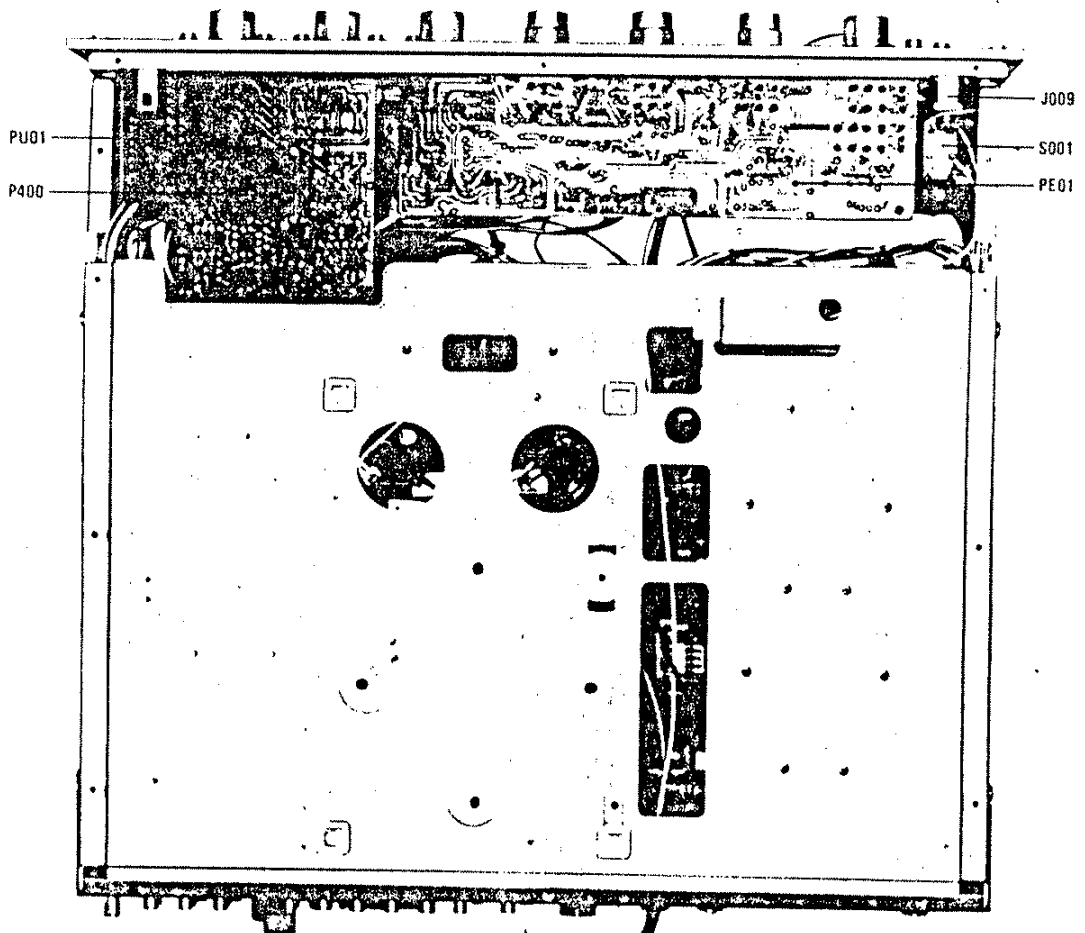

11

11

11.5 PACKING MATERIAL EXPLODED VIEW

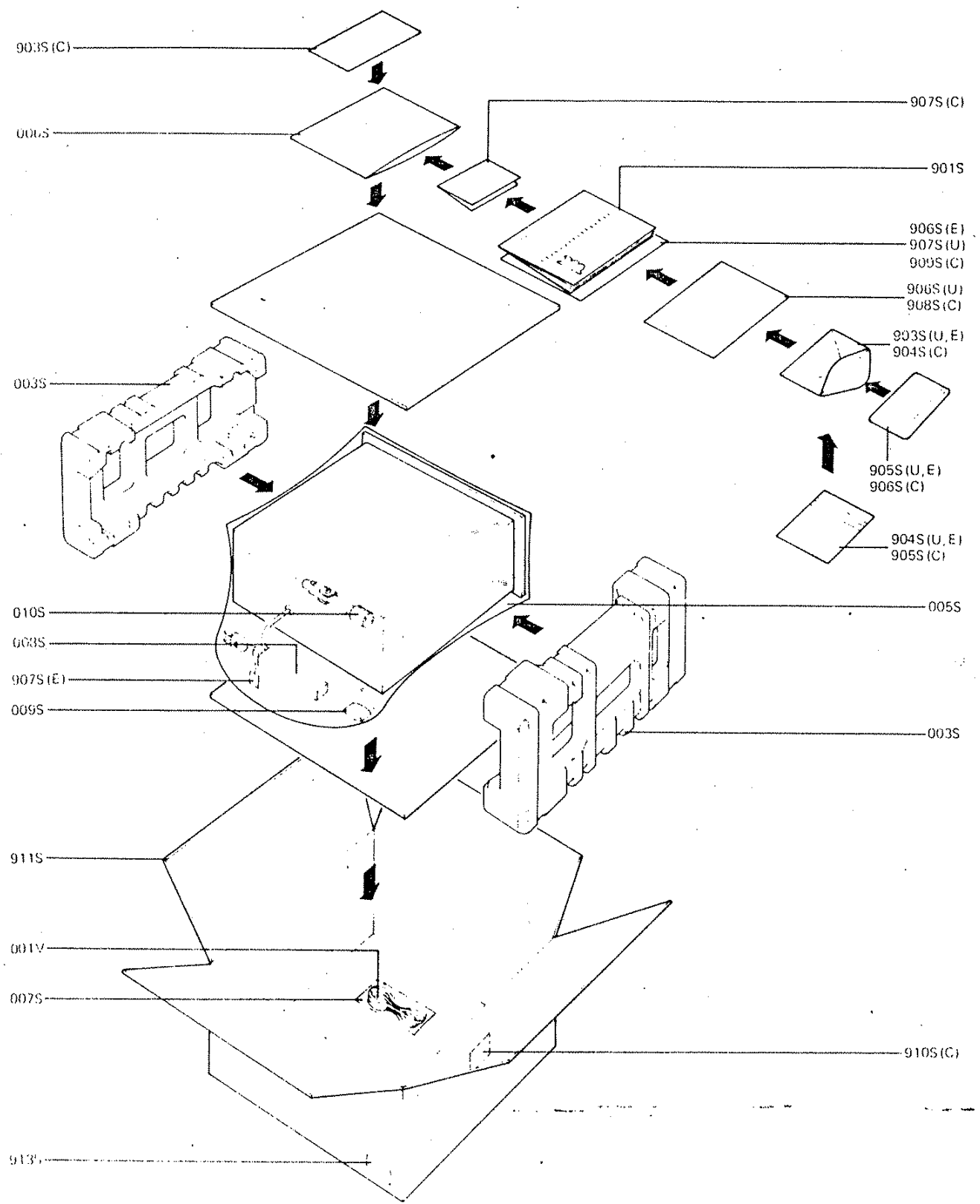

12. PARTS LIST

U: For U.S.A.
C: For Canada
E: For Europe

REF. DESIG.	Q'TY			PART NO.	DESCRIPTION
	U	C	E		
A	1	1		2219063400	Front Panel Assembly
A1			1	2219063410	Front Panel Assembly
002B	1	1	1	2218063040	Escutcheon
003B	1	1	1	2218063030	Escutcheon
004B	10	10	10	51280308B0	B.H. Tapped Screw, B3x8ST
007B	1	1	1	2219158210	Window
008B	1	1	1	2219158220	Window
011B	1	1	1	2218053010	Cover
016B	16	16	16	2978259010	Bushing
018B	1	1	1	2854259110	Bushing
901B	1	1		2219063024	Escutcheon
901B			1	2219063120	Escutcheon
902B	1	1		2219063014	Escutcheon
902B			1	2219063110	Escutcheon
B	1	1	1	2218257400	Lid Assembly, Upper
048B	1	1	1	2218257010	Lid
049B	4	4	4	2577118070	Spacer
C	1	1	1	2219159400	Drum Assembly
199G	1	1	1	2219159010	Drum
201G	1	1	1	71101569M0	Spring
202G	2	2	2	51064019A9	P.H.M. Screw, P4x19
D	1	1	1	1202006430	Hook Assembly
203G	1	1	1	1202258010	Hook
204G	1	1	1	72071605A0	String
E	1	1	1	2219273400	Flywheel Assembly
0011	1	1	1	2219273010	Flywheel
0071	2	2	2	2219063030	Escutcheon
0101	1	1	1	2219353010	Ring
0121	1	1	1	51820206B0	P.H.M. Screw, P2x6
PC08	1	1	1	2933118020	MECHANICAL PARTS Spacer
PC11	1	1	1	75061251P0	Jumper Wire
PE07	4	4	4	3444118050	Spacer
PE11	15	15	15	75061251P0	Jumper Wire
PN08	2	2	2	3444118050	Spacer
PS11	8	8	8	75061501P0	Jumper Wire
PT11	14	14	14	75061001P0	Jumper Wire
PX07	8	8	8	3444118050	Spacer
PX11	2	2	2	75061251P0	Jumper Wire
PY11	1	1	1	75061251P0	Jumper Wire
P208	12	12	12	2933118020	Spacer
P211	12	12	12	75061251P0	Jumper Wire
P407	4	4	4	3444118050	Spacer
P411	3	3	3	75061251P0	Jumper Wire
P707	20	20	20	3444118050	Spacer
P711	10	10	10	75061251P0	Jumper Wire
P807	12	12	12	3444118050	Spacer

REF. DESIG.	Q'TY			PART NO.	DESCRIPTION
	U	C	E		
P811	1	1	1	75061251P0	Jumper Wire
P916	1	1	1	75061251P0	Jumper Wire
001G	1	1	1	2219160013	Bracket
001V	1	1	1	ZA02000070	Ext. Antenna, FM
002G	1	1	1	2218160022	Bracket
002I	1	1	1	2219104500	Retainer
003G	1	1	1	2218160032	Bracket
003I	1	1	1	2219104010	Retainer
003S	2	2	2	2219809010	Cushion
004G	6	6	6	51280408B0	B.H. Tapped Screw, B4x8ST
004I	2	2	2	2219106010	Sustainer
005G	4	4	4	51280406B0	B.H. Tapped Screw, B4x6ST
005I	1	1	1	2219106020	Sustainer
005S	1	1	1	9015555500	Polyethylene Bag, Set
006S	1	1	1	9013025010	Polyethylene Bag, Printed Matter
007S	1	1	1	9013025010	Polyethylene Bag, Accessory
008I	1	1	1	2219112010	Shaft
008S	1	1	1	2864804010	Sleeve, AC Cord
009G	1	1	1	2218271012	Holder
009S	1	1	1	2731821010	Silicagei
010G	3	3	3	51280306B0	B.H. Tapped Screw, B3x6ST
010S	1	1	1	2819056010	Buffer, Ferrite-rod Antenna
011G	1	1	1	2219053020	Cover
012G	1	1	1	2218274012	Reflector
013G	2	2	2	53110303E9	Hexagon Nut
013I	1	1	1	59031405G9	Washer
014B	4	4	4	52017059J0	H. Head Bolt
014G	2	2	2	51100308S9	B.H.M. Screw, B3x8
015G	1	1	1	2219107010	Sheet
017G	1	1	1	2219401012	Frame
017I	4	4	4	51470306A9	L. Washer Screw
018G	2	2	2	51280306U0	B.H. Tapped Screw, P3x6ST
019B	1	1	1	2219107020	Sheet
019G	1	1	1	2904302020	Dial
020B	1	1	1	2219101010	Support
020G	1	1	1	2904303013	Mask
021B	2	2	2	53118129G0	Hexagon Nut
022B	1	1	1	2219101020	Support
022G	1	1	1	2854160030	Bracket
023G	2	2	2	51280306B0	B.H. Tapped Screw, B3x6ST
024G	2	2	2	51100306S9	B.H.M. Screw, B3x6
031B	3	3	3	2221154230	Knob
031G	3	3	3	2219055020	Collar
032B	1	1	1	2221154140	Knob
032G	1	1	1	2219109012	Shield
033B	3	3	3	2210154220	Knob
033G	1	1	1	2219357012	Rod
034B	3	3	3	2210154210	Knob
034G	3	3	3	51100314A9	B.H.M. Screw, B3x14
035G	1	1	1	2207005010	Clamper
036B	10	10	10	2218154010	Knob
036G	1	1	1	2904056012	Buffer
037B	5	5	5	2218154020	Knob
037G	1	1	1	2904056022	Buffer
038G	1	1	1	2904005030	Clamper
039B	1	1	1	2970154013	Knob
039G	1	1	1	5402030150	Flat Washer P.
040G	1	1	1	51100308S9	B.H.M. Screw, B3x8
041B	1	1	1	2970154032	Knob

REF. DESIG.	Q'TY			PART NO.	DESCRIPTION
	U	C	E		
041G	2	2	2	51100304S9	B.H.M. Screw, B3x4
042G	1	1	1	2219053010	Cover
043B	3	3	3	2219154010	Knob
044B	2	2	2	51690306Q9	Socket Screw, HP
044G	1	1	1	2218051010	Guide
045B	4	4	4	2759057012	Leg
045G	2	2	2	51100306A9	B.H.M. Screw, B3x6
046B	4	4	4	51570410S9	P. Tapped Screw, P4x10
048G	6	6	6	51100306A9	B.H.M. Screw, B3x6
049G	2	2	2	51100306A9	B.H.M. Screw, B3x6
050B	6	6	6	51280306U0	B.H. Tapped Screw, B3x6ST
050G	2	2	2	51100306A9	B.H.M. Screw, B3x6
051B	6	6	6	51480406S9	F. Washer Screw
051G	1	1	1	2219120010	Insulator
052G	2	2	2	51280306B0	B.H. Tapped Screw, B3x6ST
053B	1	1	1	2218257020	Lid
053G	1	1	1	2207109020	Shield
054B	13	13	13	51280410U0	B.H. Tapped Screw, B4x10ST
054G	2	2	2	51100306A9	B.H.M. Screw, B3x6
061B	8	8	8	51280306U0	B.H. Tapped Screw, B3x6
061G	1	1	1	2218262500	Pulley
062B	4	4	4	51280308U0	B.H. Tapped Screw, B3x8ST
062G	1	1	1	2218160150	Bracket
063B	2	2	2	51280308U0	B.H. Tapped Screw, B3x8ST
063G	2	2	2	51103029A0	B.H.M. Screw, B3x29
064B	12	12	12	51280308U0	B.H. Tapped Screw, B3x8ST
064G	2	2	2	2991262010	Pulley
065B	1	1	1	2218271060	Holder
066B	1	1	1	2218271070	Holder
066G	2	2	2	51280306B0	B.H. Tapped Screw, B3x6ST
068B	1	1	1	2219202010	Net
069B	4	4	4	2219055010	Collar
070B	1	1	1	2219118012	Spacer
070G	1	1	1	2218262510	Pulley
071B	4	4	4	2219259020	Bushing
071G	1	1	1	2218160160	Bracket
072B	4	4	4	2219160042	Bracket
072G	3	3	3	51103029A0	B.H.M. Screw, B3x29
073B	4	4	4	51100318S9	B.H.M. Screw, B3x18
073G	3	3	3	2991262010	Pulley
074B	4	4	4	51100308S9	B.H.M. Screw, B3x8
074G	2	2	2	51280306B0	B.H. Tapped Screw, B3x6ST
076B	2	2	2	51280306U0	B.H. Tapped Screw, B3x6ST
076G	1	1	1	2218103500	Pointer
077G	1	1	1	2218103010	Pointer
078B	1	1	1	2219202022	Net
078G	1	1	1	2218103020	Pointer
079B	2	2	2	2219202032	Net
079G	1	1	1	2218152010	Tube
080B	2	2	2	2219202042	Net
080G	1	1	1	2218280010	Housing
081G	1	1	1	2218118010	Spacer
082G	1	1	1	1N10080410	Lamp, 8V 50mA
091G	1	1	1	2219015013	Chassis
092G	1	1	1	2218105022	Chassis
093G	1	1	1	2218267022	Heatsink
094G	3	3	3	51280306B0	B.H. Tapped Screw, B3x6ST
095G	3	3	3	51280306U0	B.H. Tapped Screw, B3x6ST
096G	2	2	2	2218271020	Holder
097G	2	2	2	51280312B0	B.H. Tapped Screw, B3x12ST

REF. DESIG.	Q'TY			PART NO.	DESCRIPTION
	U	C	E		
099G	4	4	4	53250501A0	Special Nut
100G	6	6	6	51280408B0	B.H. Tapped Screw, B4x8ST
101G	6	6	6	51280408B0	B.H. Tapped Screw, B4x8ST
102G	1	1	1	2207861020	Label
105G	1	1	1	2917267022	Heatsink
106G	1	1	1	53110303E9	Hexagon Nut
107G	1	1	1	51100308S9	B.H.M. Screw, B3x8
110G	1	1	1	2219267020	Heatsink
111G	2	2	2	51280306U0	B.H. Tapped Screw, B3x6
112G	3	3	3	51280306U0	B.H. Tapped Screw, B3x6
113G	3	3	3	2219259030	Bushing
121G	1	1	1	2218123010	Contact
122G	1	1	1	51280306B0	B.H. Tapped Screw, B3x6ST
124G	1	1	1	2886005050	Clamper
125G	1	1	1	2886005060	Clamper
126G	1	1	1	2218259020	Bushing
131G	2	2	2	2219267013	Heatsink
132G	16	16	16	2219267030	Heatsink
133G	2	2	2	2219160102	Bracket
134G	2	2	2	2219160113	Bracket
135G	32	32	32	2219259010	Bushing
136G	32	32	32	51100316A9	B.H.M. Screw, B3x16
138G	2	2	2	51280312U0	B.H. Tapped Screw, B3x12ST
139G	4	4	4	51280306U0	B.H. Tapped Screw, B3x6ST
140G	2	2	2	51100304S9	B.H.M. Screw, B3x4
141G	4	4	4	51280306U0	B.H. Tapped Screw, B3x6ST
151G	12	12	12	51100306S9	B.H.M. Screw, B3x6
153G	8	8	8	2917267022	Heatsink
154G	4	4	4	51100310S9	B.H.M. Screw, B3x10
155G	4	4	4	51100308S9	B.H.M. Screw, B3x8
156G	8	8	8	53110303E9	Hexagon Nut
158G	1	1	1	2219160082	Bracket
159G	6	6	6	51280306U0	B.H. Tapped Screw, B3x6ST
160G	4	4	4	51280306U0	B.H. Tapped Screw, B3x6ST
161G	2	2	2	51280306U0	B.H. Tapped Screw, B3x6ST
162G	1	1	1	2207269010	Protector
163G	10	10	10	51280308B0	B.H. Tapped Screw, B3x8ST
164G	1	1	1	2207861010	Label
166G	1	1	1	2219160050	Bracket
167G	2	2	2	51280408B0	B.H. Tapped Screw, B4x8ST
168G	2	2	2	51280306B0	B.H. Tapped Screw, B3x6ST
169G	2	2	2	51280306B0	B.H. Tapped Screw, B3x6ST
171G	4	4	4	2887005110	Clamper
172G	3	3	3	51280306B0	B.H. Tapped Screw, B3x6ST
181G	1	1	1	2218160050	Bracket
182G	6	6	6	51280306U0	B.H. Tapped Screw, B3x6ST
183G	2	2	2	2218160060	Bracket
184G	4	4	4	51280306B0	B.H. Tapped Screw, B3x6ST
185G	2	2	2	51280306B0	B.H. Tapped Screw, B3x6ST
186G	2	2	2	2218160092	Bracket
187G	4	4	4	51280306B0	B.H. Tapped Screw, B3x6ST
188G	2	2	2	51280306B0	B.H. Tapped Screw, B3x6ST
189G	1	1	1	2908109022	Shield
191G	4	4	4	51100306S9	B.H.M. Screw, B3x6
193G	1	1	1	2218160080	Bracket
194G	4	4	4	51280306B0	B.H. Tapped Screw, B3x6ST
195G	1	1	1	2218160040	Bracket
196G	2	2	2	51100306A0	B.H.M. Screw, B3x6
197G	5	5	5	51280306B0	B.H. Tapped Screw, B3x6ST
198G	2	2	2	2891056010	Buffer

U : For U.S.A.
C : For Canada
E : For Europe

REF. DESIG.	Q'TY			PARTS NO.	DESCRIPTION
	U	C	E		
200G	1	1	1	56382540G0	Eyelet
203G	1	1	1	1202258010	Hook
211G	1	1	1	2219160020	Bracket
212G	2	2	2	51280306B0	B.H. Tapped Screw, B3x6ST
213G	2	2	2	51280306U0	B.H. Tapped Screw, B3x6ST
214G	2	2	2	2219267040	Heatsink
215G	4	4	4	54040302N0	Spring Washer
216G	4	4	4	50020305B9	Screw
217G	1	1	1	2207005022	Clamper
219G	1	1	1	51280306B0	B.H. Tapped Screw, B3x6ST
220G	1	1	1	54050300A0	T.L. Washer OR
221G	4	4	4	62030039W0	Lug
222G	4	4	4	51280306B0	B.H. Tapped Screw, B3x6ST
224G	2	2	2	2891056010	Buffer
226G	1	1	1	2908259010	Bushing
227G	1	1	1	2991005010	Clamper
228G	1	1	1	51280306B0	B.H. Tapped Screw, B3x6ST
801B	1	1	1	2218271050	Holder
802B	1	1	1	2218258010	Hook
803B	1	1	1	2218257030	Lid
804B	2	2	2	51280308U0	B.H. Tapped Screw, B3x8ST
805B	2	2	2	51280308U0	B.H. Tapped Screw, B3x8ST
901G	2	2	1	2218274032	Reflector
901S	1	1	1	2219851010	Instructions
901S	1	1	1	2219851310	Instructions
902G	1	1	1	2218302010	Dial
902G	1	1	1	2218302020	Dial
903B	8	8	9	2979259022	Bushing
903S	1	1	1	2577813010	Envelope
903S	1	1	1	2818813010	Envelope
903S	1	1	1	2886851100	Instructions
904S	1	1	1	2577851020	Instructions
904S	1	1	1	2818851120	Instructions
904S	1	1	1	2918813012	Envelope
905B	1	1	1	2219160214	Bracket
905B	1	1	1	2219160220	Bracket
905S	1	1	1	2577854012	Guarantee Card
905S	1	1	1	2818851120	Instructions
905S	1	1	1	9630000180	Guarantee Card
906S	1	1	1	2818851140	Instructions
906S	1	1	1	2818854023	Guarantee Card
906S	1	1	1	9630000180	Guarantee Card
907S	1	1	1	2818851040	Instructions
907S	1	1	1	9560000042	Hang Tag
907S	1	1	1	9650000050	Service Station Card
908B	1	1	1	1455259040	Bushing
908B	1	1	1	1455259100	Bushing
908S	1	1	1	2818811010	Polyethylene Bag
908S	1	1	1	2818854042	Guarantee Card
909B	1	1	2	62040029W0	Lug
909S	1	1	1	2818851140	Instructions
909S	1	1	1	9660000010	QC Card
910S	2	2	2	9510901020	Label
911B	1	1	1	2219265010	Indicator
911B	1	1	1	2219265022	Indicator
911B	1	1	1	2219265040	Indicator
911S	1	1	1	2219801010	Packing Case
912B	1	1	1	2506265060	Indicator
912B	1	1	1	2911861170	Label
913B	1	1	1	2578861010	Label

REF. DESIG.	Q'TY			PARTS NO.	DESCRIPTION
	U	C	E		
913B	4	4	4	2911861110	Label
913S	7	7	7	9522815010	Serial No. Card
913S	7	7	7	9523015110	Serial No. Card
913S	4	4	4	9523015120	Serial No. Card
914B	1	1	1	2911861140	Label
914B	1	1	1	2932861010	Label
915B	2	2	2	51100308S9	B.H.M. Screw, B3x8
915B	1	1	1	9510911010	Label
915B	1	1	1	9510911020	Label
916B	1	1	1	2457861040	Label
916B	1	1	1	9511101020	Label
917B	1	1	1	2911861190	Label
917B	1	1	1	9510221010	Label
918B	1	1	1	2911861160	Label
919B	1	1	1	2911861300	Label
ELECTRICAL PARTS					
CB01	1	1	1	DD12100010	Cap., Ceramic, 10pF
CB02	1	1	1	DF16683010	Cap., Film, 0.068μF
CB03	1	1	1	DF17403010	Cap., Film, 0.04μF
CB04	1	1	1	DK18104020	Cap., Ceramic, 0.1μF
CB05	1	1	1	DK18403020	Cap., Ceramic, 0.04μF
CB06	1	1	1	EA10601690	Cap., Elect., 10μF, 16V
JB01	1	1	1	YP10001130	Plug
JB02	1	1	1	YP10001130	Plug
JB03	1	1	1	YP10001130	Plug
JB04	1	1	1	YP10001130	Plug
LB01	1	1	1	LC21050010	Choke Coil, 1mH
PB00	1	1	1	YA22180610	P.W. Board, FM Noise Amp
PB00	1	1	1	Z222180610	P.W. Board Assembly
QB01	1	1	1	HT308281D0	Transistor, 2SC828S
QB02	1	1	1	HT308281D0	Transistor, 2SC828S
QB03	1	1	1	HD10001050	Diode, 1N60
QB04	1	1	1	HD10001050	Diode, 1N60
RB01	1	1	1	RT05562140	Res., Fixed, 5.6kΩ ±5%, ¼W
RB02	1	1	1	RT05104140	Res., Fixed, 100kΩ ±5%, ¼W
RB03	1	1	1	RT05273140	Res., Fixed, 27kΩ ±5%, ¼W
RB04	1	1	1	RT05102140	Res., Fixed, 1kΩ ±5%, ¼W
RB05	1	1	1	RT05273140	Res., Fixed, 27kΩ ±5%, ¼W
RB06	1	1	1	RT05333140	Res., Fixed, 33kΩ ±5%, ¼W
RB07	1	1	1	RT05221140	Res., Fixed, 220Ω ±5%, ¼W
RB08	1	1	1	RT05101140	Res., Fixed, 100Ω ±5%, ¼W
RB09	1	1	1	RT05101140	Res., Fixed, 100Ω ±5%, ¼W
CC01	1	1	1	EV47403560	Cap., Elect., 0.47μF, 35V
CC02	1	1	1	EV47403560	Cap., Elect., 0.47μF, 35V
CC03	1	1	1	EV10503560	Cap., Elect., 1μF, 35V
CC04	1	1	1	EV10503560	Cap., Elect., 1μF, 35V
CC05	1	1	1	EV10503560	Cap., Elect., 1μF, 35V
CC06	1	1	1	EV10503560	Cap., Elect., 1μF, 35V
CC07	1	1	1	EA22702590	Cap., Elect., 220μF, 25V
CC08	1	1	1	EA47503590	Cap., Elect., 4.7μF, 35V
JC01	1	1	1	YP10001130	Plug
JC02	1	1	1	YP10001130	Plug
JC03	1	1	1	YP10001130	Plug
JC04	1	1	1	YP10001130	Plug
JC05	1	1	1	YP10001130	Plug

U : For U.S.A.
C : For Canada
E : For Europe

REF. DESIG.	Q'TY			PART NO.	DESCRIPTION
	U	C	E		
JC06	1	1	1	YP10001130	Plug
JC07	1	1	1	YP10001130	Plug
JC08	1	1	1	YP10001130	Plug
JC09	1	1	1	YP10001130	Plug
JC10	1	1	1	YP10001130	Plug
JC11	1	1	1	YP10001130	Plug
JC12	1	1	1	YP10001130	Plug
LC01	1	1	1	LY20240120	Relay
PC01	1	1	1	YA22180220	P.W. Board, FM Buffer Amp
	1	1	1	ZZ22192070	P.W. Board Assembly
RC01	1	1	1	RA05020130	Res., Semifixed, 4.7kΩ
RC02	1	1	1	RA05020130	Res., Semifixed, 4.7kΩ
RC03	1	1	1	RT05101140	Res., Fixed, 100Ω ±5%, ¼W
RC04	1	1	1	RT05101140	Res., Fixed, 100Ω ±5%, ¼W
RC05	1	1	1	RT05155140	Res., Fixed, 1.5MΩ ±5%, ¼W
RC06	1	1	1	RT05155140	Res., Fixed, 1.5MΩ ±5%, ¼W
RC07	1	1	1	RT05913140	Res., Fixed, 91kΩ ±5%, ¼W
RC08	1	1	1	RT05913140	Res., Fixed, 91kΩ ±5%, ¼W
RC09	1	1	1	RT05223140	Res., Fixed, 22kΩ ±5%, ¼W
RC10	1	1	1	RT05223140	Res., Fixed, 22kΩ ±5%, ¼W
RC11	1	1	1	RT05431140	Res., Fixed, 430Ω ±5%, ¼W
RC12	1	1	1	RT05431140	Res., Fixed, 430Ω ±5%, ¼W
RC13	1	1	1	RT05101140	Res., Fixed, 100Ω ±5%, ¼W
RC14	1	1	1	RT05101140	Res., Fixed, 100Ω ±5%, ¼W
RC15	1	1	1	RT05272140	Res., Fixed, 2.7kΩ ±5%, ¼W
RC16	1	1	1	RT05272140	Res., Fixed, 2.7kΩ ±5%, ¼W
RC17	1	1	1	RT05562140	Res., Fixed, 5.6kΩ ±5%, ¼W
RC18	1	1	1	RT05562140	Res., Fixed, 5.6kΩ ±5%, ¼W
RC19	1	1	1	RT05561140	Res., Fixed, 560Ω ±5%, ¼W
RC20	1	1	1	RT05561140	Res., Fixed, 560Ω ±5%, ¼W
RC21	1	1	1	RT05224140	Res., Fixed, 220kΩ ±5%, ¼W
RC22	1	1	1	RT05224140	Res., Fixed, 220kΩ ±5%, ¼W
RC23	1	1	1	RT05224140	Res., Fixed, 220kΩ ±5%, ¼W
RC24	1	1	1	RT05224140	Res., Fixed, 220kΩ ±5%, ¼W
RC25	1	1	1	RT05101140	Res., Fixed, 100Ω ±5%, ¼W
RC26	1	1	1	RT05152140	Res., Fixed, 1.5kΩ ±5%, ¼W
RC27	1	1	1	RT05102140	Res., Fixed, 1kΩ ±5%, ¼W
RC28	1	1	1	RT05102140	Res., Fixed, 1kΩ ±5%, ¼W
CD01	1	1	1	DF17103010	Cap., Film, 0.01μF, 50V
CD02	1	1	1	DF17103010	Cap., Film, 0.01μF, 50V
CD03	1	1	1	DF17104010	Cap., Film, 0.1μF, 50V
CD04	1	1	1	DF17104010	Cap., Film, 0.1μF, 50V
CD05	1	1	1	DK17203010	Cap., Ceramic, 0.02μF, 50V
JD01	1	1	1	YP06000580	Plug, 5P, Basepost
JD02	1	1	1	YP06000570	Plug, 3P, Basepost
PD01	1	1	1	YK22190610	P.W. Board, Buffer Amp for Scope Input
	1	1	1	ZZ22190610	P.W. Board Assembly
QD01	1	1	1	HF20030100	F.E.T., 2SK30A Y
QD02	1	1	1	HF20030100	F.E.T., 2SK30A Y
RD01	1	1	1	GD05105140	Res., Fixed, 1MΩ ±5%, ¼W
RD02	1	1	1	GD05105140	Res., Fixed, 1MΩ ±5%, ¼W
RD03	1	1	1	GD05152140	Res., Fixed, 1.5kΩ ±5%, ¼W
RD04	1	1	1	GD05152140	Res., Fixed, 1.5kΩ ±5%, ¼W
RD05	1	1	1	GD05105140	Res., Fixed, 1MΩ ±5%, ¼W
RD06	1	1	1	GD05105140	Res., Fixed, 1MΩ ±5%, ¼W

REF. DESIG.	Q'TY			PART NO.	DESCRIPTION
	U	C	E		
RD07	1	1	1	RM02540390	Res., Variable, 250kΩ (A), Scope Level
RD08	1	1	1	GD05153140	Res., Fixed, 15kΩ ±5%, ¼W
RD09	1	1	1	GD05153140	Res., Fixed, 15kΩ ±5%, ¼W
CE01	1	1	1	EE22503510	Cap., Elect., 2.2μF, 35V
CE02	1	1	1	EE22503510	Cap., Elect., 2.2μF, 35V
CE03	1	1	1	EE22601640	Cap., Elect., 22μF, 16V
CE04	1	1	1	EE22601640	Cap., Elect., 22μF, 16V
CE05	1	1	1	EA10601690	Cap., Elect., 10μF, 16V
CE06	1	1	1	EA10601690	Cap., Elect., 10μF, 16V
CE07	1	1	1	DD15500050	Cap., Ceramic, 50pF, 50V
CE08	1	1	1	DD15500050	Cap., Ceramic, 50pF, 50V
CE09	1	1	1	DD12100010	Cap., Ceramic, 10pF, 50V
CE10	1	1	1	DD12100010	Cap., Ceramic, 10pF, 50V
CE11	1	1	1	EE10505040	Cap., Elect., 1μF, 50V
CE12	1	1	1	EE10505040	Cap., Elect., 1μF, 50V
CE13	1	1	1	EE47502540	Cap., Elect., 4.7μF, 35V
CE14	1	1	1	EE47502540	Cap., Elect., 4.7μF, 35V
CE15	1	1	1	DD15500050	Cap., Ceramic, 50pF, 50V
CE16	1	1	1	DD15500050	Cap., Ceramic, 50pF, 50V
CE17	1	1	1	DD16200010	Cap., Ceramic, 20pF, 50V
CE18	1	1	1	DD16200010	Cap., Ceramic, 20pF, 50V
CE19	1	1	1	DF16123010	Cap., Film, 0.012μF, 50V
CE20	1	1	1	DF16123010	Cap., Film, 0.012μF, 50V
CE21	1	1	1	DF16123010	Cap., Film, 0.012μF, 50V
CE22	1	1	1	DF16123010	Cap., Film, 0.012μF, 50V
CE23	1	1	1	DF17224020	Cap., Film, 0.22μF, 50V
CE24	1	1	1	DF17224020	Cap., Film, 0.22μF, 50V
CE25	1	1	1	DF16682010	Cap., Film, 6800pF, 50V
CE26	1	1	1	DF16682010	Cap., Film, 6800pF, 50V
CE27	1	1	1	DD16501010	Cap., Ceramic, 500pF, 50V
CE28	1	1	1	DD16501010	Cap., Ceramic, 500pF, 50V
CE29	1	1	1	DF16222010	Cap., Film, 2200pF, 50V
CE30	1	1	1	DF16222010	Cap., Film, 2200pF, 50V
CE31	1	1	1	DF16332010	Cap., Film, 3300pF, 50V
CE32	1	1	1	DF16332010	Cap., Film, 3300pF, 50V
CE33	1	1	1	DD15201010	Cap., Ceramic, 200pF, 50V
CE34	1	1	1	DD15201010	Cap., Ceramic, 200pF, 50V
CE35	1	1	1	EA10701690	Cap., Elect., 100μF, 16V
CE36	1	1	1	EA10701690	Cap., Elect., 100μF, 16V
CE37	1	1	1	DD12100010	Cap., Ceramic, 10pF, 50V
CE38	1	1	1	DD12100010	Cap., Ceramic, 10pF, 50V
CE41	1	1	1	DK18103010	Cap., Ceramic, 0.01μF, 50V
CE42	1	1	1	DK18103010	Cap., Ceramic, 0.01μF, 50V
CE43	1	1	1	DF16392010	Cap., Film, 3900pF, 50V
CE44	1	1	1	DF16392010	Cap., Film, 3900pF, 50V
CE45	1	1	1	DF16392010	Cap., Film, 3900pF, 50V
CE46	1	1	1	DF16392010	Cap., Film, 3900pF, 50V
CE47	1	1	1	DD12030010	Cap., Ceramic, 3pF, 50V
CE48	1	1	1	DD12030010	Cap., Ceramic, 3pF, 50V
JE01	1	1	1	YP06001040	Plug, 3P, Basepost
JE02	1	1	1	YP06001040	Plug, 3P, Basepost
JE04	1	1	1	YP06001040	Plug, 3P, Basepost
JE05	1	1	1	YP06000490	Plug, 9P, Amp
JE06	1	1	1	YP06000740	Plug, 3P, Amp
JE07	1	1	1	YP06000740	Plug, 3P, Amp
PE01	1	1	1	YA22180210	P.W. Board, Pre and Tone Amp
	1	1	1	ZZ22192130	P.W. Board Assembly

U: For U.S.A.
C: For Canada
E: For Europe

REF. DESIG.	Q'TY			PART NO.	DESCRIPTION
	U	C	E		
QE01	1	1	1	HC10022050	I.C., TA7136P
QE02	1	1	1	HC10022050	I.C., TA7136P
QE03	1	1	1	HC10022050	I.C., TA7136P
QE04	1	1	1	HC10022050	I.C., TA7136P
RE03	1	1	1	RN05105140	Res., Fixed, 1M Ω \pm 5%, 1/4W
RE04	1	1	1	RN05105140	Res., Fixed, 1M Ω \pm 5%, 1/4W
RE05	1	1	1	RT05104140	Res., Fixed, 100k Ω \pm 5%, 1/4W
RE06	1	1	1	RT05104140	Res., Fixed, 100k Ω \pm 5%, 1/4W
RE07	1	1	1	RT05154140	Res., Fixed, 150k Ω \pm 5%, 1/4W
RE08	1	1	1	RT05154140	Res., Fixed, 150k Ω \pm 5%, 1/4W
RE09	1	1	1	RT05203140	Res., Fixed, 20k Ω \pm 5%, 1/4W
RE10	1	1	1	RT05203140	Res., Fixed, 20k Ω \pm 5%, 1/4W
RE11	1	1	1	RT05105140	Res., Fixed, 1M Ω \pm 5%, 1/4W
RE12	1	1	1	RT05105140	Res., Fixed, 1M Ω \pm 5%, 1/4W
RE13	1	1	1	RT05103140	Res., Fixed, 10k Ω \pm 5%, 1/4W
RE14	1	1	1	RT05103140	Res., Fixed, 10k Ω \pm 5%, 1/4W
RE15	1	1	1	RT05105140	Res., Fixed, 1M Ω \pm 5%, 1/4W
RE16	1	1	1	RT05105140	Res., Fixed, 1M Ω \pm 5%, 1/4W
RE17	1	1	1	RN05104140	Res., Fixed, 100k Ω \pm 5%, 1/4W
RE18	1	1	1	RN05104140	Res., Fixed, 100k Ω \pm 5%, 1/4W
RE19	1	1	1	RT05224140	Res., Fixed, 220k Ω \pm 5%, 1/4W
RE20	1	1	1	RT05224140	Res., Fixed, 220k Ω \pm 5%, 1/4W
RE21	1	1	1	RT05113140	Res., Fixed, 11k Ω \pm 5%, 1/4W
RE22	1	1	1	RT05113140	Res., Fixed, 11k Ω \pm 5%, 1/4W
RE23	1	1	1	RT05113140	Res., Fixed, 11k Ω \pm 5%, 1/4W
RE24	1	1	1	RT05113140	Res., Fixed, 11k Ω \pm 5%, 1/4W
RE25	1	1	1	RT05183140	Res., Fixed, 18k Ω \pm 5%, 1/4W
RE26	1	1	1	RT05183140	Res., Fixed, 18k Ω \pm 5%, 1/4W
RE27	1	1	1	RT05183140	Res., Fixed, 18k Ω \pm 5%, 1/4W
RE28	1	1	1	RT05183140	Res., Fixed, 18k Ω \pm 5%, 1/4W
RE29	1	1	1	RT05273140	Res., Fixed, 27k Ω \pm 5%, 1/4W
RE30	1	1	1	RT05273140	Res., Fixed, 27k Ω \pm 5%, 1/4W
RE31	1	1	1	RT05562140	Res., Fixed, 5.6k Ω \pm 5%, 1/4W
RE32	1	1	1	RT05562140	Res., Fixed, 5.6k Ω \pm 5%, 1/4W
RE33	1	1	1	RT05183140	Res., Fixed, 18k Ω \pm 5%, 1/4W
RE34	1	1	1	RT05183140	Res., Fixed, 18k Ω \pm 5%, 1/4W
RE35	1	1	1	RT05183140	Res., Fixed, 18k Ω \pm 5%, 1/4W
RE36	1	1	1	RT05183140	Res., Fixed, 18k Ω \pm 5%, 1/4W
RE39	1	1	1	RD01040070	Res., Variable, 100k Ω (B), Bass
RE40	1	1	1	RD01040070	Res., Variable, 100k Ω (B), Mid
RE41	1	1	1	RD01040070	Res., Variable, 100k Ω (B), Treble
RE42	1	1	1	RG02030010	Res., Variable, 20k Ω (B)/250k Ω (V), Volume
RE43	1	1	1	RT05562140	Res., Fixed, 5.6k Ω \pm 5%, 1/4W
RE44	1	1	1	RT05562140	Res., Fixed, 5.6k Ω \pm 5%, 1/4W
RE45	1	1	1	RT05562140	Res., Fixed, 5.6k Ω \pm 5%, 1/4W
RE46	1	1	1	RT05562140	Res., Fixed, 5.6k Ω \pm 5%, 1/4W
RE47	1	1	1	GU05122120	Res., Fixed, 1.2k Ω \pm 5%, 1/4W
RE48	1	1	1	GU05122120	Res., Fixed, 1.2k Ω \pm 5%, 1/4W
SE01	1	1	1	SR04050130	Rotary Switch, Tone Mode
JK01	1	1	1	YP10001130	Plug
JK02	1	1	1	YP10001130	Plug
JK03	1	1	1	YP10001130	Plug
JK04	1	1	1	YP10001130	Plug
JK05	1	1	1	YP10001130	Plug
JK06	1	1	1	YP10001130	Plug
JK07	1	1	1	YP10001130	Plug
JK08	1	1	1	YP10001130	Plug
JK09	1	1	1	YJ07000120	Jack, 10P, PC Connector

REF. DESIG.	Q'TY			PART NO.	DESCRIPTION
	U	C	E		
PK01	1	1	1	YA22180310	P.W. Board, Dolby Socket
	1	1	1	ZZ22180310	P.W. Board Assembly
SK01	1	1	1	SC01020240	Micro Switch
SK02	1	1	1	SC01020240	Micro Switch
JM01	2	2	2	YP06001340	Plug, 4P
JM02	2	2	2	YP06001340	Plug, 4P
JM03	2	2	2	YP06001330	Plug, 8P
JM04	2	2	2	YJ06001380	Jack, 3P
JM05	2	2	2	YJ06001380	Jack, 3P
JM06	2	2	2	YJ06001380	Jack, 3P
PM01	2	2	2	YF22190010	P.W. Board, Power Transistor Assembly
QM01	2	2	2	HV00007080	Varistor, STV-4H
QM02	2	2	2	HT315682B0	Transistor, 2SC1568 R or S
QM03	2	2	2	HT406103A0	Transistor, 2SD610 S, R or Q
QM04	2	2	2	HT206303A0	Transistor, 2SB630 S, R or Q
QM05	2	2	2	HT405553A0	Transistor, 2SD555 S, Q or R
QM06	2	2	2	HT405553A0	Transistor, 2SD555 S, Q or R
QM07	2	2	2	HT405553A0	Transistor, 2SD555 S, Q or R
QM08	2	2	2	HT206003A0	Transistor, 2SB600 S, Q or R
QM09	2	2	2	HT206003A0	Transistor, 2SB600 S, Q or R
QM10	2	2	2	HT206003A0	Transistor, 2SB600 S, Q or R
QM11	2	2	2	HT405553A0	Transistor, 2SD555 S, Q or R
QM12	2	2	2	HT206003A0	Transistor, 2SB600 S, Q or R
CN01	1	1	1	EA22700690	Cap., Elect., 220 μ F, 6.3V
JN01	1	1	1	YP10001130	Plug
JN02	1	1	1	YP10001130	Plug
JN05	1	1	1	YP10001200	Plug
JN06	1	1	1	YP10001200	Plug
JN07	1	1	1	YP10001200	Plug
LN01	1	1	1	LY20480020	Relay, MSJ2, 48V
PN01	1	1	1	YA22180510	P.W. Board, Audio Muting
	1	1	1	ZZ22191080	P.W. Board Assembly
QN01	1	1	1	HT406673A0	Transistor, 2SD667A B, C or D
QN02	1	1	1	HD20005010	Diode, W06B
RN01	1	1	1	RT05474140	Res., Fixed, 470k Ω \pm 5%, 1/4W
RN02	1	1	1	RT05101140	Res., Fixed, 100 Ω \pm 5%, 1/4W
RN03	1	1	1	RT05223140	Res., Fixed, 22k Ω \pm 5%, 1/4W
RN04	1	1	1	RT05223140	Res., Fixed, 22k Ω \pm 5%, 1/4W
RN05	1	1	1	GJ05182010	Res., Fixed, 1.8k Ω \pm 5%, 1W
RN06	1	1	1	RT05473140	Res., Fixed, 47k Ω \pm 5%, 1/4W
PR01	1	1	1	YF22190020	P.W. Board, Wiring for Tape Copy & Monitor
CS01	1	1	1	DF17473050	Cap., Film, 0.047 μ F, 50V
CS02	1	1	1	EA10601690	Cap., Elect., 10 μ F, 16V
CS03	1	1	1	EV33403560	Cap., Elect., 0.33 μ F, 35V
CS04	1	1	1	EV22403560	Cap., Elect., 0.22 μ F, 35V
CS05	1	1	1	DF16333050	Cap., Film, 0.033 μ F, 50V
JS01	1	1	1	YP06001350	Plug, 10P
JS02	1	1	1	YP06001290	Plug, 8P
JS03	1	1	1	YP06001050	Plug, 5P
JS04	1	1	1	YP06001050	Plug, 5P, Basepost
JS05	1	1	1	YP06001040	Plug, 3P, Basepost
JS06	1	1	1	YP06000570	Plug, 3P, Basepost
JS07	1	1	1	YP06000580	Plug, 5P, Basepost
KS01	1	1	1	YK22191400	P.W. Board, Scope & Tape Moni. Switches & Dubbing Jacks

U : For U.S.A.
C : For Canada
E : For Europe

REF. DESIG.	Q'TY			PART NO.	DESCRIPTION
	U	C	E		
PS01	1	1	1	YK22191410	P.W. Board, Tape Copy, Tape Moni., & Scope Display Switches
	1	1	1	ZZ22191210	P.W. Board Assembly
RS01	1	1	1	RT05103140	Res., Fixed, 10kΩ ±5%, ¼W
RS02	1	1	1	RT05100140	Res., Fixed, 10Ω ±5%, ¼W
RS03	1	1	1	RT05221140	Res., Fixed, 220Ω ±5%, ¼W
RS04	1	1	1	RT05224140	Res., Fixed, 200kΩ ±5%, ¼W
RS05	1	1	1	RT05473140	Res., Fixed, 47kΩ ±5%, ¼W
RS06	1	1	1	RT05473140	Res., Fixed, 47kΩ ±5%, ¼W
RS07	1	1	1	RT05224140	Res., Fixed, 220kΩ ±5%, ¼W
RS08	1	1	1	RT05304140	Res., Fixed, 300kΩ ±5%, ¼W
RS09	1	1	1	RT05304140	Res., Fixed, 300kΩ ±5%, ¼W
SS01	1	1	1	SP04080020	Pushswitch, Tape Copy, Tape Moni., & Scope Display
CT01	1	1	1	DF15104010	Cap., Film, 0.1μF, 50V
CT02	1	1	1	DF15104010	Cap., Film, 0.1μF, 50V
CT03	1	1	1	DF15104010	Cap., Film, 0.1μF, 50V
CT04	1	1	1	DF15104010	Cap., Film, 0.1μF, 50V
CT05	1	1	1	DF15104010	Cap., Film, 0.1μF, 50V
CT06	1	1	1	DF15104010	Cap., Film, 0.1μF, 50V
CT07	1	1	1	DF15152010	Cap., Film, 0.0015μF, 50V
CT08	1	1	1	DF15152010	Cap., Film, 0.0015μF, 50V
CT09	1	1	1	DF15222010	Cap., Film, 0.0022μF, 50V
CT10	1	1	1	DF15222010	Cap., Film, 0.0022μF, 50V
CT11	1	1	1	DF17224010	Cap., Film, 0.22μF, 50V
CT12	1	1	1	DF17224010	Cap., Film, 0.22μF, 50V
CT13	1	1	1	DD15391010	Cap., Ceramic, 390pF, 50V
CT14	1	1	1	DD15391010	Cap., Ceramic, 390pF, 50V
CT15	1	1	1	DD11050010	Cap., Ceramic, 5pF, 50V
CT16	1	1	1	DD11050010	Cap., Ceramic, 5pF, 50V
CT17	1	1	1	DD16151010	Cap., Ceramic, 150pF, 50V
CT18	1	1	1	DD16151010	Cap., Ceramic, 150pF, 50V
CT19	1	1	1	DF16333010	Cap., Film, 0.033μF, 50V
CT20	1	1	1	DF16333010	Cap., Film, 0.033μF, 50V
CT21	1	1	1	EE10602540	Cap., Elect., 10μF, 25V
CT22	1	1	1	EE10602540	Cap., Elect., 10μF, 25V
CT23	1	1	1	EA10701690	Cap., Elect., 100μF, 16V
CT24	1	1	1	EA10701690	Cap., Elect., 100μF, 16V
CT25	1	1	1	DF16153010	Cap., Film, 0.015μF, 50V
JT01	1	1	1	YP06000340	Plug, 3P, Amp
JT02	1	1	1	YP06000340	Plug, 3P, Amp
JT03	1	1	1	YP06000700	Plug, 9P, Amp
JT04	1	1	1	YP06000580	Plug, 5P, Basepost
JT05	1	1	1	YP06001050	Plug, 5P, Basepost
PT01	1	1	1	YK22190220	P.W. Board, Filter Amp
	1	1	1	ZZ22192020	P.W. Board Assembly
QT01	1	1	1	HT316812A0	Transistor, 2SC1681 GR or BL
QT02	1	1	1	HT316812A0	Transistor, 2SC1681 GR or BL
QT03	1	1	1	HT316812A0	Transistor, 2SC1681 GR or BL
QT04	1	1	1	HT316812A0	Transistor, 2SC1681 GR or BL
QT05	1	1	1	HT108412A0	Transistor, 2SA841 GR or BL
QT06	1	1	1	HT108412A0	Transistor, 2SA841 GR or BL
RT01	1	1	1	GD05114140	Res., Fixed, 110kΩ ±5%, ¼W
RT02	1	1	1	GD05114140	Res., Fixed, 110kΩ ±5%, ¼W
RT03	1	1	1	GD05244140	Res., Fixed, 240kΩ ±5%, ¼W
RT04	1	1	1	GD05244140	Res., Fixed, 240kΩ ±5%, ¼W
RT05	1	1	1	GD05113140	Res., Fixed, 11kΩ ±5%, ¼W

REF. DESIG.	Q'TY			PART NO.	DESCRIPTION
	U	C	E		
RT06	1	1	1	GD05113140	Res., Fixed, 11kΩ ±5%, ¼W
RT07	1	1	1	GD05225140	Res., Fixed, 2.2MΩ ±5%, ¼W
RT08	1	1	1	GD05225140	Res., Fixed, 2.2MΩ ±5%, ¼W
RT09	1	1	1	GD05113140	Res., Fixed, 11kΩ ±5%, ¼W
RT10	1	1	1	GD05113140	Res., Fixed, 11kΩ ±5%, ¼W
RT11	1	1	1	GD05113140	Res., Fixed, 11kΩ ±5%, ¼W
RT12	1	1	1	GD05113140	Res., Fixed, 11kΩ ±5%, ¼W
RT13	1	1	1	GD05513140	Res., Fixed, 51kΩ ±5%, ¼W
RT14	1	1	1	GD05513140	Res., Fixed, 51kΩ ±5%, ¼W
RT15	1	1	1	GD05225140	Res., Fixed, 2.2MΩ ±5%, ¼W
RT16	1	1	1	GD05225140	Res., Fixed, 2.2MΩ ±5%, ¼W
RT17	1	1	1	GD05225140	Res., Fixed, 2.2MΩ ±5%, ¼W
RT18	1	1	1	GD05222140	Res., Fixed, 2.2kΩ ±5%, ¼W
RT19	1	1	1	GD05113140	Res., Fixed, 11kΩ ±5%, ¼W
RT20	1	1	1	GD05113140	Res., Fixed, 11kΩ ±5%, ¼W
RT21	1	1	1	GD05562140	Res., Fixed, 5.6kΩ ±5%, ¼W
RT22	1	1	1	GD05562140	Res., Fixed, 5.6kΩ ±5%, ¼W
RT23	1	1	1	GD05103140	Res., Fixed, 10kΩ ±5%, ¼W
RT24	1	1	1	GD05103140	Res., Fixed, 10kΩ ±5%, ¼W
RT25	1	1	1	GD05274140	Res., Fixed, 270kΩ ±5%, ¼W
RT26	1	1	1	GD05274140	Res., Fixed, 270kΩ ±5%, ¼W
RT27	1	1	1	GD05301140	Res., Fixed, 300Ω ±5%, ¼W
RT28	1	1	1	GD05301140	Res., Fixed, 300Ω ±5%, ¼W
RT29	1	1	1	GD05104140	Res., Fixed, 100kΩ ±5%, ¼W
RT30	1	1	1	GD05104140	Res., Fixed, 100kΩ ±5%, ¼W
RT31	1	1	1	GD05153140	Res., Fixed, 15kΩ ±5%, ¼W
RT32	1	1	1	GD05153140	Res., Fixed, 15kΩ ±5%, ¼W
RT33	1	1	1	GD05102140	Res., Fixed, 1kΩ ±5%, ¼W
RT34	1	1	1	GD05102140	Res., Fixed, 1kΩ ±5%, ¼W
RT35	1	1	1	GD05334140	Res., Fixed, 330kΩ ±5%, ¼W
RT36	1	1	1	GD05334140	Res., Fixed, 330kΩ ±5%, ¼W
RT37	1	1	1	GD05225140	Res., Fixed, 2.2MΩ ±5%, ¼W
RT38	1	1	1	GD05225140	Res., Fixed, 2.2MΩ ±5%, ¼W
RT39	1	1	1	GD05124140	Res., Fixed, 120kΩ ±5%, ¼W
RT40	1	1	1	GD05124140	Res., Fixed, 120kΩ ±5%, ¼W
ST01	1	1	1	SP02050030	Pushswitch
JU01	1	1	1	YJ01001040	Jack, Dubbing In
JU02	1	1	1	YJ01001050	Jack, Dubbing Out
JU03	1	1	1	YJ06001350	Jack, 10P
JU04	1	1	1	YJ06001370	Jack, 4P
JU05	1	1	1	YJ06001370	Jack, 4P
JU06	1	1	1	YP06000570	Plug, 3P, Basepost
JU07	1	1	1	YP06000570	Plug, 3P, Basepost
PU01	1	1	1	YK22191420	P.W. Board, Dubbing Jacks
	1	1	1	ZZ22191220	P.W. Board Assembly
JW01	1	1	1	YP10001200	Plug
JW02	1	1	1	YP10001200	Plug
JW03	1	1	1	YP10001200	Plug
JW04	1	1	1	YP10001200	Plug
JW05	1	1	1	YP10001200	Plug
PW01	1	1	1	YD22180050	P.W. Board, Speaker Switches
	1	1	1	ZZ22180050	P.W. Board Assembly
RW01	1	1	1	GS10331070	Res., Fixed, 330Ω ±10%, 7W
RW02	1	1	1	GS10331070	Res., Fixed, 330Ω ±10%, 7W
RW03	1	1	1	GJ05151020	Res., Fixed, 150Ω ±5%, 2W
RW04	1	1	1	GJ05151020	Res., Fixed, 150Ω ±5%, 2W

U : For U.S.A.
C : For Canada
E : For Europe

REF. DESIG.	QTY			PART NO.	DESCRIPTION
	U	C	E		
SW01	1	1	1	SP04020180	Pushswitch, Speakers
WW01	1	1	1	YB00630010	Connective Cord
WW02	1	1	1	YB00630020	Connective Cord
CX01	1	1	1	EA47505090	Cap., Elect., 4.7 μ F, 50V
CX02	1	1	1	EA47505090	Cap., Elect., 4.7 μ F, 50V
CX03	1	1	1	EA10700690	Cap., Elect., 100 μ F, 6.3V
CX04	1	1	1	EA10701090	Cap., Elect., 100 μ F, 10V
CX05	1	1	1	EA10610010	Cap., Elect., 10 μ F, 100V
CX06	1	1	1	EA22601090	Cap., Elect., 22 μ F, 10V
JX01	1	1	1	YJ06001300	Jack, 6P
JX02	1	1	1	YJ06001300	Jack, 6P
JX03	1	1	1	YP06000570	Plug, 3P
JX04	1	1	1	YP06000570	Plug, 3P
JX05	1	1	1	YP06000600	Plug, 5P
PX01	1	1	1	YK22190210	P.W. Board, Peak Ind. & Soft Start
	1	1	1	ZZ22190210	P.W. Board Assembly
QX01	1	1	1	HT315733A0	Transistor, 2SC1573 P, Q or R
QX02	1	1	1	HT315733A0	Transistor, 2SC1573 P, Q or R
QX03	1	1	1	HT109412A0	Transistor, 2SA941 GR or BL
QX04	1	1	1	HT109412A0	Transistor, 2SA941 GR or BL
QX05	1	1	1	HT109412A0	Transistor, 2SA941 GR or BL
QX06	1	1	1	HT109412A0	Transistor, 2SA941 GR or BL
QX07	1	1	1	HT309452A0	Transistor, 2SC945 Q or R
QX08	1	1	1	HT309452A0	Transistor, 2SC945 Q or R
QX09	1	1	1	HT309452A0	Transistor, 2SC945 Q or R
QX10	1	1	1	HT309452A0	Transistor, 2SC945 Q or R
QX11	1	1	1	HD20011010	Diode, W06C, 200V 0.75A
QX12	1	1	1	HD20011010	Diode, W06C, 200V 0.75A
QX13	1	1	1	HD20001210	Diode, 1S2473, 35V
QX14	1	1	1	HD20001210	Diode, 1S2473, 35V
QX15	1	1	1	HD20001210	Diode, 1S2473, 35V
QX16	1	1	1	HD20001210	Diode, 1S2473, 35V
QX17	1	1	1	HD30023090	Zener, WZ-071, 7.1V
QX18	1	1	1	HD30023090	Zener, WZ-071, 7.1V
QX19	1	1	1	HT107332A0	Transistor, 2SA733 R or Q
QX20	1	1	1	HT107332A0	Transistor, 2SA733 R or Q
QX21	1	1	1	HT206472B0	Transistor, 2SB647A C or D
QX22	1	1	1	HT107332A0	Transistor, 2SA733 R or Q
QX23	1	1	1	HV00003120	Varistor, MV13
QX24	1	1	1	HV00003120	Varistor, MV13
QX25	1	1	1	HD20001210	Diode, 1S2473
QX26	1	1	1	HD20001210	Diode, 1S2473
QX27	1	1	1	HD20005010	Diode, W06B
QX28	1	1	1	HD30023090	Zener, WZ-071
RX01	1	1	1	RT05103140	Res., Fixed, 10k Ω \pm 5%, $\frac{1}{4}$ W
RX02	1	1	1	RT05103140	Res., Fixed, 10k Ω \pm 5%, $\frac{1}{4}$ W
RX03	1	1	1	RT05303140	Res., Fixed, 30k Ω \pm 5%, $\frac{1}{4}$ W
RX04	1	1	1	RT05303140	Res., Fixed, 30k Ω \pm 5%, $\frac{1}{4}$ W
RX05	1	1	1	RT05393140	Res., Fixed, 39k Ω \pm 5%, $\frac{1}{4}$ W
RX06	1	1	1	RT05393140	Res., Fixed, 39k Ω \pm 5%, $\frac{1}{4}$ W
RX07	1	1	1	RT05103140	Res., Fixed, 10k Ω \pm 5%, $\frac{1}{4}$ W
RX08	1	1	1	RT05103140	Res., Fixed, 10k Ω \pm 5%, $\frac{1}{4}$ W
RX09	1	1	1	RT05222140	Res., Fixed, 2.2k Ω \pm 5%, $\frac{1}{4}$ W
RX10	1	1	1	RT05222140	Res., Fixed, 2.2k Ω \pm 5%, $\frac{1}{4}$ W
RX11	1	1	1	RT05243140	Res., Fixed, 24k Ω \pm 5%, $\frac{1}{4}$ W
RX12	1	1	1	RT05243140	Res., Fixed, 24k Ω \pm 5%, $\frac{1}{4}$ W
RX13	1	1	1	RT05473140	Res., Fixed, 47k Ω \pm 5%, $\frac{1}{4}$ W

REF. DESIG.	QTY			PART NO.	DESCRIPTION
	U	C	E		
RX14	1	1	1	RT05473140	Res., Fixed, 47k Ω \pm 5%, $\frac{1}{4}$ W
RX15	1	1	1	RT05473140	Res., Fixed, 47k Ω \pm 5%, $\frac{1}{4}$ W
RX16	1	1	1	RT05473140	Res., Fixed, 47k Ω \pm 5%, $\frac{1}{4}$ W
RX17	1	1	1	RT05753140	Res., Fixed, 75k Ω \pm 5%, $\frac{1}{4}$ W
RX18	1	1	1	RT05753140	Res., Fixed, 75k Ω \pm 5%, $\frac{1}{4}$ W
RX19	1	1	1	RT05753140	Res., Fixed, 75k Ω \pm 5%, $\frac{1}{4}$ W
RX20	1	1	1	RT05753140	Res., Fixed, 75k Ω \pm 5%, $\frac{1}{4}$ W
RX21	1	1	1	RT05223140	Res., Fixed, 22k Ω \pm 5%, $\frac{1}{4}$ W
RX22	1	1	1	RT05223140	Res., Fixed, 22k Ω \pm 5%, $\frac{1}{4}$ W
RX23	1	1	1	RT05511140	Res., Fixed, 510 Ω \pm 5%, $\frac{1}{4}$ W
RX24	1	1	1	RT05511140	Res., Fixed, 510 Ω \pm 5%, $\frac{1}{4}$ W
RX25	1	1	1	RT05753140	Res., Fixed, 75k Ω \pm 5%, $\frac{1}{4}$ W
RX26	1	1	1	RT05753140	Res., Fixed, 75k Ω \pm 5%, $\frac{1}{4}$ W
RX27	1	1	1	RT05512140	Res., Fixed, 5.1k Ω \pm 5%, $\frac{1}{4}$ W
RX28	1	1	1	RT05512140	Res., Fixed, 5.1k Ω \pm 5%, $\frac{1}{4}$ W
RX29	1	1	1	RT05822140	Res., Fixed, 8.2k Ω \pm 5%, $\frac{1}{4}$ W
RX30	1	1	1	RT05822140	Res., Fixed, 8.2k Ω \pm 5%, $\frac{1}{4}$ W
RX31	1	1	1	RT05104140	Res., Fixed, 100k Ω \pm 5%, $\frac{1}{4}$ W
RX32	1	1	1	RT05104140	Res., Fixed, 100k Ω \pm 5%, $\frac{1}{4}$ W
RX33	1	1	1	GJ05392020	Res., Fixed, 3.9k Ω \pm 5%, 2W
RX34	1	1	1	GJ05392020	Res., Fixed, 3.9k Ω \pm 5%, 2W
RX35	1	1	1	RT05332140	Res., Fixed, 3.3k Ω \pm 5%, $\frac{1}{4}$ W
RX36	1	1	1	RT05753140	Res., Fixed, 75k Ω \pm 5%, $\frac{1}{4}$ W
RX37	1	1	1	RT05822140	Res., Fixed, 8.2k Ω \pm 5%, $\frac{1}{4}$ W
RX38	1	1	1	RT05104140	Res., Fixed, 1M Ω \pm 5%, $\frac{1}{4}$ W
RX39	1	1	1	GJ05472020	Res., Fixed, 4.7k Ω \pm 5%, 2W
RX40	1	1	1	RT05472140	Res., Fixed, 4.7k Ω \pm 5%, $\frac{1}{4}$ W
RX41	1	1	1	RT05154140	Res., Fixed, 150k Ω \pm 5%, $\frac{1}{4}$ W
RX42	1	1	1	RT05562140	Res., Fixed, 5.6k Ω \pm 5%, $\frac{1}{4}$ W
RX43	1	1	1	GJ05152020	Res., Fixed, 1.5k Ω \pm 5%, 2W
RX44	1	1	1	RT05273140	Res., Fixed, 27k Ω \pm 5%, $\frac{1}{4}$ W
RX45	1	1	1	RT05274140	Res., Fixed, 270k Ω \pm 5%, $\frac{1}{4}$ W
CY01	1	1	1	EA47601690	Cap., Elect., 47 μ F, 16V
JY01	1	1	1	YP10001200	Plug
JY03	1	1	1	YP10001200	Plug
JY04	1	1	1	YP10001200	Plug
JY05	1	1	1	YP10001200	Plug
JY08	1	1	1	YP10001200	Plug
JY09	1	1	1	YP10001200	Plug
JY10	1	1	1	YP10001200	Plug
JY13	1	1	1	YP10001200	Plug
JY14	1	1	1	YP10001200	Plug
JY15	1	1	1	YP10001200	Plug
JY16	1	1	1	YP10001200	Plug
JY17	1	1	1	YP10001200	Plug
JY18	1	1	1	YP10001200	Plug
JY19	1	1	1	YP10001200	Plug
JY20	1	1	1	YP10001200	Plug
JY23	1	1	1	YP10001200	Plug
JY24	1	1	1	YP10001200	Plug
PY01	1	1	1	YD22180030	P.W. Board, Function Indicator
	1	1	1	ZZ22191030	P.W. Board Assembly
	1	1	1	ZZ22198030	P.W. Board Assembly
QY01	1	1	1	HI10004030	L.E.D., Peak Ind. (R)
QY02	1	1	1	HI10004030	L.E.D., Peak Ind. (L)
QY03	1	1	1	HI10004030	L.E.D., Tape
QY04	1	1	1	HI10004030	L.E.D., Tape

U : For U.S.A.
C : For Canada
E : For Europe

REF. DESIG.	Q'TY			PART NO.	DESCRIPTION
	U	C	E		
QY05	1	1	1	HI10004030	L.E.D., Aux 1
QY06	1	1	1	HI10004030	L.E.D., Phono 2
QY07	1	1	1	HI10004030	L.E.D., Phono 1
QY08	1	1	1	HI10004030	L.E.D., FM
QY09	1	1	1	HI10004030	L.E.D., AM
QY10	1	1	1	HD20001210	Diode, 1S2473
QY10	1	1	1	HD20005010	Diode, W06B
RY01	1	1	1	RT05751140	Res., Fixed, 750Ω ±5%, ¼W
RY02	1	1	1	RT05751140	Res., Fixed, 750Ω ±5%, ¼W
JZ01	1	1	1	YP10001130	Plug
JZ02	1	1	1	YP10001130	Plug
JZ03	1	1	1	YP10001130	Plug
JZ04	1	1	1	YP10001130	Plug
JZ05	1	1	1	YJ08000170	Jack
JZ06	1	1	1	YJ08000170	Jack
JZ07	1	1	1	YJ08000170	Jack
JZ08	1	1	1	YJ08000170	Jack
JZ09	1	1	1	YJ08000170	Jack
JZ10	1	1	1	YJ08000170	Jack
JZ11	1	1	1	YJ08000170	Jack
JZ12	1	1	1	YJ08000170	Jack
JZ13	1	1	1	YJ08000170	Jack
JZ14	1	1	1	YJ08000170	Jack
JZ15	1	1	1	YJ08000170	Jack
JZ16	1	1	1	YJ08000170	Jack
JZ17	1	1	1	YJ08000170	Jack
JZ18	1	1	1	YP10001130	Plug
JZ19	1	1	1	YP10001130	Plug
JZ20	1	1	1	YP10001130	Plug
JZ21	1	1	1	YP10001130	Plug
PZ01	1	1	1	YD22180040	P.W. Board, Dial Lamp
	1	1	1	ZZ22191040	P.W. Board Assembly
VZ01	1	1	1	IN10080070	Lamp, 8V 0.2A
VZ02	1	1	1	IN10080070	Lamp, 8V 0.2A
VZ03	1	1	1	IN10080070	Lamp, 8V 0.2A
VZ04	1	1	1	IN10080070	Lamp, 8V 0.2A
VZ05	1	1	1	IN10080070	Lamp, 8V 0.2A
VZ06	1	1	1	IN10080070	Lamp, 8V 0.2A
C001	1	1	1	DK17103010	Cap., Ceramic, 0.01μF, 50V
C002	1	1	1	DK17103010	Cap., Ceramic, 0.01μF, 50V
C003	1	1	1	ES72810010	Cap., Elect., 7200μF, 100V
C004	1	1	1	ES72810010	Cap., Elect., 7200μF, 100V
C005	1	1	1	DO07473540	Cap., Oil-paper, 0.047μF, 450V
C006	1	1	1	DF17223520	Cap., Film, 0.022μF, 400V
C007	1	1	1	DF17223520	Cap., Film, 0.022μF, 400V
F001	2	2	2	FR30800010	Circuit Breaker
F002	2	2	2	FR30800010	Circuit Breaker
F003	2	2	2	FR30600010	Circuit Breaker
F004	2	2	2	FR30600010	Circuit Breaker
F005	1	1	1	FS10800810	Fuse
F005	1	1	1	FS11500010	Fuse
F005	1	1	1	FS11500020	Fuse
F006	1	1	1	FS21500970	Fuse
G001	1	1	1	BF10400030	Cap. Comp., Spark Killer
G001	1	1	1	BF33300020	Cap. Comp., Spark Killer
J001	1	1	1	BY04050010	Terminal
J002	1	1	1	YT02010130	Terminal, FM Quad. Output
J003	1	1	1	YT02040190	Terminal, Phono

REF. DESIG.	Q'TY			PART NO.	DESCRIPTION
	U	C	E		
J004	1	1	1	YT02040140	Terminal, Tape Moni, 1 In & Out
J005	1	1	1	YT02040140	Terminal, Tape Moni, 2 In & Out
J006	1	1	1	YT02040170	Terminal, Pre Out & Main In
J007	1	1	1	YT03040160	Terminal, Spk. System 1
J008	1	1	1	YT03040160	Terminal, Spk. System 2
J009	1	1	1	YJ01001060	Jack, Phones
J010	1	1	1	YT01010050	Terminal, Chassis Ground
J011	1	1	1	YJ05000182	Jack, C.R.T. Socket
J012	1	1	1	YJ06001390	Jack, Main In (L)
J013	1	1	1	YJ06001400	Jack, Main In (R)
J014	1	1	1	YJ06001050	Jack, 5P
J015	1	1	1	YJ06001050	Jack, 5P
J016	1	1	1	YJ06001360	Jack, 5P
J017	1	1	1	YJ06000320	Jack, 5P
J018	1	1	1	YJ06001050	Jack, 5P
J019	1	1	1	YJ06001250	Jack, 5P
J020	1	1	1	YJ06001050	Jack, 5P
J021	1	1	1	YJ06001050	Jack, 5P
J022	1	1	1	YJ06001050	Jack, 5P
J023	1	1	1	YJ06001050	Jack, 5P
J024	1	1	1	YJ06001050	Jack, 5P
J025	1	1	1	YJ06001240	Jack, 3P
J026	1	1	1	YJ06001240	Jack, 3P
J027	1	1	1	YJ06001240	Jack, 3P
J028	1	1	1	YJ06001040	Jack, 3P
J029	1	1	1	YJ06001040	Jack, 3P
J030	1	1	1	YJ06001040	Jack, 3P
J031	1	1	1	YJ06001040	Jack, 3P
J032	1	1	1	YJ06001040	Jack, 3P
J033	1	1	1	YJ06001240	Jack, 3P
J034	1	1	1	YL01030010	Terminal, 3P
J035	1	1	1	YJ04000560	Jack, AC Outlet
J035	1	1	1	YJ04000590	Jack, 3P
J036	1	1	1	YJ04000560	Jack, AC Outlet
J036	1	1	1	YJ04000590	Jack, 3P
J037	1	1	1	YT02020140	Terminal, 2P, Aux
J037	1	1	1	YT02040140	Terminal, 4P, Aux 1 & 2
J038	1	1	1	YJ06001410	Jack, 11P, Relay Socket
J038	1	1	1	YJ06001420	Jack, 11P, Relay Socket
J039	1	1	1	YJ08000220	Jack, Fuse Holder
J039	1	1	1	YJ08000240	Jack, Fuse Holder
J040	1	1	1	BY03110010	Plug, Voltage Selector
J041	1	1	1	YJ06001040	Jack, 3P
J042	1	1	1	YJ06001050	Jack, 5P
L001	1	1	1	LF11200520	Coil, AM Antenna
L002	1	1	1	LC11540020	Choke Coil, AM
L003	1	1	1	LB30075260	Balun Coil
L004	1	1	1	LY30480010	Relay, Soft Start
L005	1	1	1	TS44502010	Power Transformer
L005	1	1	1	TS44502020	Power Transformer
M001	1	1	1	MI01150010	AC Motor
M001	1	1	1	MI01150020	AC Motor
Q001	1	1	1	HE20001290	Diode, S5VB40
Q002	1	1	1	HE20001290	Diode, S5VB40
R001	1	1	1	RK02030160	Res., Variable, 20kΩ(B), Muting Level
R002	1	1	1	RA05030180	Res., Semifixed, 50kΩ(B), Bright

U: For U.S.A.
C: For Canada
E: For Europe

REF. DESIG.	Q'TY			PART NO.	DESCRIPTION
	U	C	E		
R003	1	1	1	RK02040060	Res., Variable, 200kΩ(B), Focus
R004	1	1	1	RB01030240	Res., Variable, 10kΩ(B), Vertical
R005	1	1	1	RB01030240	Res., Variable, 10kΩ(B), Horizontal
R006	1	1	1	RT05100140	Res., Fixed, 10Ω±5%, ¼W
R007	1	1	1	RS02030110	Res., Variable, 20kΩ(MN), Balance
R008	1	1	1	RT05472140	Res., Fixed, 4.7kΩ ±5%, ¼W
R009	1	1	1	GS05472020	Res., Fixed, 4.7kΩ ±5%, 2.5W
R010	1	1	1	GS05472020	Res., Fixed, 4.7kΩ ±5%, 2.5W
R012	1	1	1	GQ10821100	Res., Fixed, 820Ω ±5%, 10W
R013	1	1	1	GQ10100100	Res., Fixed, 10Ω ±10%, 10W
R013	1	1	1	GS10220200	Res., Fixed, 22Ω ±10%, 20W
S001	1	1	1	SP04010230	Pushswitch, Power
S001	1	1	1	SP04010250	Pushswitch, Power
V001	1	1	1	VB00235012	Cathod Bay Tube
V002	2	2	2	IN10080410	Lamp, 8V 50mA
V003	1	1	1	IN10080340	Lamp, 8V 60mA, Stereo
V004	1	1	1	IN10080340	Lamp, 8V 60mA
V005	1	1	1	IN10080340	Lamp, Dolby
W001	1	1	1	YC01900030	AC Power Cord
W001	1	1	1	YC02400270	AC Power Cord
W010	1	1	1	YB00600060	Connective Cord
W011	1	1	1	YB00600070	Connective Cord
W012	1	1	1	YB00600080	Connective Cord
W013	1	1	1	YB00600090	Connective Cord
W014	1	1	1	YB00450010	Connective Cord
W015	1	1	1	YB00160030	Connective Cord
W016	1	1	1	YB00660010	Connective Cord
W017	1	1	1	YB00510010	Connective Cord
W018	1	1	1	YB00160020	Connective Cord
W019	1	1	1	YB00140020	Connective Cord
C101	1	1	1	DD16150010	Cap., Ceramic, 15pF ±10%
C102	1	1	1	DD16101010	Cap., Ceramic, 47pF ±5%
C103	1	1	1	DD16101010	Cap., Ceramic, 100pF ±10%
C104	1	1	1	DK18203030	Cap., Ceramic, 0.02μF+80%, -20%
C105	1	1	1	DK18203030	Cap., Ceramic, 0.02μF+80%, -20%
C106	1	1	1	DK18203030	Cap., Ceramic, 0.02μF+80%, -20%
C107	1	1	1	DD16180020	Cap., Ceramic, 18pF ±10%
C108	1	1	1	DD16180020	Cap., Ceramic, 18pF ±10%
C109	1	1	1	DK18203030	Cap., Ceramic, 0.02μF+80%, -20%
C110	1	1	1	DK18203030	Cap., Ceramic, 0.02μF+80%, -20%
C111	1	1	1	DD16101010	Cap., Ceramic, 100pF ±10%
C112	1	1	1	DK18203030	Cap., Ceramic, 0.02μF+80%, -20%
C113	1	1	1	DK18203030	Cap., Ceramic, 0.02μF+80%, -20%
C114	1	1	1	DD12100010	Cap., Ceramic, 10pF ±10%
C115	1	1	1	DD16180020	Cap., Ceramic, 18pF ±10%
C116	1	1	1	DK18203030	Cap., Ceramic, 0.02μF+80%, -20%
C117	1	1	1	DD11080010	Cap., Ceramic, 8pF ±0.5pF
C118	1	1	1	DD10010020	Cap., Ceramic, 1pF ±0.5pF
C119	1	1	1	DD16150090	Cap., Ceramic, 15pF ±10%
C120	1	1	1	DD12100090	Cap., Ceramic, 10pF ±10%

REF. DESIG.	Q'TY			PART NO.	DESCRIPTION
	U	C	E		
C121	1	1	1	DK18203030	Cap., Ceramic, 0.02μF+80%, -20%
C122	1	1	1	CA53700010	Cap., Variable, FM-5, AM-3
C123	1	1	1	CT10500030	Cap., Trimmer, 3pF~8pF
C151	1	1	1	DF17103010	Cap., Film, 0.01μF
C152	1	1	1	DF17102010	Cap., Film, 0.001μF
C153	1	1	1	DF17103010	Cap., Film, 0.01μF
C155	1	1	1	DF17103010	Cap., Film, 0.01μF
C156	1	1	1	DF65391010	Cap., Film, 390pF
C157	1	1	1	DF17403010	Cap., Film, 0.04μF
C158	1	1	1	DD16101010	Cap., Ceramic, 100pF
C159	1	1	1	DF17403010	Cap., Film, 0.04μF
C160	1	1	1	DF17102010	Cap., Film, 0.001μF
C161	1	1	1	EA47503590	Cap., Elect., 4.7μF, 35V
C162	1	1	1	EA33505090	Cap., Elect., 3.3μF, 50V
C163	1	1	1	DF17473010	Cap., Film, 0.047μF
C164	1	1	1	DF17103010	Cap., Film, 0.01μF
C165	1	1	1	DK17103010	Cap., Ceramic, 0.01μF
C166	1	1	1	EV10403560	Cap., Elect., 0.1μF, 35V
C167	1	1	1	EV10503560	Cap., Elect., 1μF, 35V
C168	1	1	1	DK17502010	Cap., Ceramic, 0.005μF
C169	1	1	1	EA10701690	Cap., Elect., 100μF, 16V
C170	1	1	1	DK18403020	Cap., Ceramic, 0.04μF
C171	1	1	1	DK18403020	Cap., Ceramic, 0.04μF
C172	1	1	1	EA10701690	Cap., Elect., 100μF, 16V
F151	1	1	1	FF10045160	Ceramic Filter
J101	1	1	1	YJ06001150	Jack
J102	1	1	1	YJ06001150	Jack
J103	1	1	1	YJ06001150	Jack
J104	1	1	1	YJ06001150	Jack
J105	1	1	1	YJ06001150	Jack
L105	1	1	1	LI71016060	I.F.T., FM
L151	1	1	1	LA10010190	Coil, RF
L152	1	1	1	LO10010480	Coil, OSC
L153	1	1	1	LI10015010	I.F.T., AM
L154	1	1	1	LI10015060	I.F.T., AM
L155	1	1	1	LC13320020	Choke Coil
P100	1	1	1	YD22180020	P.W. Board, FM Front End
	1	1	1	AV01202080	Front End Assembly
Q101	1	1	1	HF400591A0	F.E.T., 3SK59
Q102	1	1	1	HF400591A0	F.E.T., 3SK59
Q103	1	1	1	HF400591A0	F.E.T., 3SK59
Q104	1	1	1	HC10029050	I.C., TA7301P
Q151	1	1	1	HC10019010	I.C., HA1197
Q152	1	1	1	HT313272A0	Transistor, 2SC1327 S or T
R101	1	1	1	GD05473140	Res., Fixed, 47kΩ ±5%, ¼W
R102	1	1	1	GD05123140	Res., Fixed, 12kΩ ±5%, ¼W
R103	1	1	1	GD05473140	Res., Fixed, 47kΩ ±5%, ¼W
R104	1	1	1	GD05223140	Res., Fixed, 22kΩ ±5%, ¼W
R105	1	1	1	GD05101140	Res., Fixed, 100Ω ±5%, ¼W
R106	1	1	1	GD05101140	Res., Fixed, 100Ω ±5%, ¼W
R107	1	1	1	GD05182140	Res., Fixed, 1.8kΩ ±5%, ¼W
R108	1	1	1	GD05473140	Res., Fixed, 47kΩ ±5%, ¼W
R109	1	1	1	GD05123140	Res., Fixed, 12kΩ ±5%, ¼W
R110	1	1	1	GD05473140	Res., Fixed, 47kΩ ±5%, ¼W
R111	1	1	1	GD05101140	Res., Fixed, 100Ω ±5%, ¼W
R112	1	1	1	GD05101140	Res., Fixed, 100Ω ±5%, ¼W
R113	1	1	1	GD05473140	Res., Fixed, 47kΩ ±5%, ¼W
R114	1	1	1	GD05561140	Res., Fixed, 560Ω ±5%, ¼W

U : For U.S.A.
C : For Canada
E : For Europe

REF. DESIG.	Q'TY			PART NO.	DESCRIPTION
	U	C	E		
R115	1	1	1	GD05101140	Res., Fixed, 100Ω ±5%, ¼W
R116	1	1	1	GD05331140	Res., Fixed, 330Ω ±5%, ¼W
R151	1	1	1	RT05201140	Res., Fixed, 220Ω ±5%, ¼W
R152	1	1	1	RT05302140	Res., Fixed, 3kΩ ±5%, ¼W
R153	1	1	1	RT05103140	Res., Fixed, 10kΩ ±5%, ¼W
R154	1	1	1	RT05103140	Res., Fixed, 10kΩ ±5%, ¼W
R155	1	1	1	RT05301140	Res., Fixed, 300Ω ±5%, ¼W
R156	1	1	1	RT05102140	Res., Fixed, 1kΩ ±5%, ¼W
R157	1	1	1	RT05204140	Res., Fixed, 200kΩ ±5%, ¼W
R158	1	1	1	RT05473140	Res., Fixed, 47kΩ ±5%, ¼W
R159	1	1	1	RT05102140	Res., Fixed, 1kΩ ±5%, ¼W
R160	1	1	1	RT05332140	Res., Fixed, 3.3kΩ ±5%, ¼W
R161	1	1	1	RT05104140	Res., Fixed, 100kΩ ±5%, ¼W
R162	1	1	1	RT05101140	Res., Fixed, 100Ω ±5%, ¼W
R163	1	1	1	RA01030250	Res., Semifixed, 10kΩ
R164	1	1	1	RT05152140	Res., Fixed, 1.5kΩ ±5%, ¼W
R165	1	1	1	RT05101140	Res., Fixed, 100Ω ±5%, ¼W
R166	1	1	1	RT05101140	Res., Fixed, 100Ω ±5%, ¼W
C201	1	1	1	DK17103010	Cap., Ceramic, 0.01μF
C202	1	1	1	DK17103010	Cap., Ceramic, 0.01μF
C203	1	1	1	DK17103010	Cap., Ceramic, 0.01μF
C204	1	1	1	DK17103010	Cap., Ceramic, 0.01μF
C205	1	1	1	DK18403010	Cap., Ceramic, 0.04μF
C206	1	1	1	DK18403010	Cap., Ceramic, 0.04μF
C207	1	1	1	DK17103010	Cap., Ceramic, 0.01μF
C208	1	1	1	DK18403010	Cap., Ceramic, 0.04μF
C209	1	1	1	DK18403010	Cap., Ceramic, 0.04μF
C210	1	1	1	DK17103010	Cap., Ceramic, 0.01μF
C211	1	1	1	DK17103010	Cap., Ceramic, 0.01μF
C212	1	1	1	DK17103010	Cap., Ceramic, 0.01μF
C213	1	1	1	DK18403020	Cap., Ceramic, 0.04μF
C214	1	1	1	DK18403020	Cap., Ceramic, 0.04μF
C215	1	1	1	DK17103010	Cap., Ceramic, 0.01μF
C216	1	1	1	DK17103010	Cap., Ceramic, 0.01μF
C217	1	1	1	DK17103010	Cap., Ceramic, 0.01μF
C218	1	1	1	DD16201010	Cap., Ceramic, 200pF
C219	1	1	1	DD16201010	Cap., Ceramic, 200pF
C220	1	1	1	DK17103010	Cap., Ceramic, 0.01μF
C221	1	1	1	DK18403020	Cap., Ceramic, 0.04μF
C222	1	1	1	DK18403020	Cap., Ceramic, 0.04μF
C223	1	1	1	EV22403560	Cap., Elect., 0.22μF, 35V
C224	1	1	1	DD16201010	Cap., Ceramic, 200pF
C225	1	1	1	DD16201010	Cap., Ceramic, 200pF
C226	1	1	1	DK16472010	Cap., Ceramic, 0.0047μF
C227	1	1	1	DK18403020	Cap., Ceramic, 0.04μF
C228	1	1	1	DD16201010	Cap., Ceramic, 200pF
C229	1	1	1	DK16152010	Cap., Ceramic, 0.0015μF
C230	1	1	1	DD16201010	Cap., Ceramic, 200pF
C231	1	1	1	DK16472010	Cap., Ceramic, 0.0047μF
C232	1	1	1	DD16201010	Cap., Ceramic, 200pF
C233	1	1	1	DD16201010	Cap., Ceramic, 200pF
C234	1	1	1	DK17103010	Cap., Ceramic, 0.01μF
C235	1	1	1	DK17103010	Cap., Ceramic, 0.01μF
C236	1	1	1	DK18403020	Cap., Ceramic, 0.04μF
C237	1	1	1	DK18403020	Cap., Ceramic, 0.04μF
C238	1	1	1	DK18403020	Cap., Ceramic, 0.04μF
C239	1	1	1	DK17103010	Cap., Ceramic, 0.01μF
C240	1	1	1	DK17103010	Cap., Ceramic, 0.01μF
C241	1	1	1	DK18403020	Cap., Ceramic, 0.04μF
C242	1	1	1	DK18403020	Cap., Ceramic, 0.04μF

REF. DESIG.	Q'TY			PART NO.	DESCRIPTION
	U	C	E		
C243	1	1	1	DD16201010	Cap., Ceramic, 200pF
C244	1	1	1	DD16201010	Cap., Ceramic, 200pF
C247	1	1	1	DD16201010	Cap., Ceramic, 200pF
C248	1	1	1	EA22601690	Cap., Elect., 22μF, 16V
C249	1	1	1	EA47601690	Cap., Elect., 47μF, 16V
C250	1	1	1	EA10701690	Cap., Elect., 100μF, 16V
C251	1	1	1	DK18403010	Cap., Ceramic, 0.04μF
C252	1	1	1	EQ22405010	Cap., Elect., 0.22μF, 50V
C253	1	1	1	EA10601690	Cap., Elect., 10μF, 16V
C254	1	1	1	EA10601690	Cap., Elect., 10μF, 16V
C255	1	1	1	EA10601690	Cap., Elect., 10μF, 16V
C256	1	1	1	CT15000010	Cap., Trimmer, 50pF
C257	1	1	1	CT15000010	Cap., Trimmer, 50pF
C258	1	1	1	CT15000010	Cap., Trimmer, 50pF
C259	1	1	1	CT15000010	Cap., Trimmer, 50pF
C260	1	1	1	CT15000010	Cap., Trimmer, 50pF
C261	1	1	1	DK18403020	Cap., Ceramic, 0.04μF
C262	1	1	1	DK18403020	Cap., Ceramic, 0.04μF
F201	1	1	1	FF11070050	Ceramic Filter, 10.7MHz
F202	1	1	1	FF11070050	Ceramic Filter, 10.7MHz
F203	1	1	1	FF11070050	Ceramic Filter, 10.7MHz
F204	1	1	1	FF11070050	Ceramic Filter, 10.7MHz
F205	1	1	1	FF11070050	Ceramic Filter, 10.7MHz
J201	1	1	1	YP10001130	Plug
J202	1	1	1	YP10001130	Plug
J203	1	1	1	YP10001130	Plug
J204	1	1	1	YP10001130	Plug
J205	1	1	1	YP10001130	Plug
J206	1	1	1	YP06000570	Plug, 3P
J207	1	1	1	YP06000570	Plug, 3P
J209	1	1	1	YP10001130	Plug
J210	1	1	1	YP10001130	Plug
J211	1	1	1	YP10001130	Plug
J212	1	1	1	YP10001130	Plug
J213	1	1	1	YP10001130	Plug
J216	1	1	1	YP10001130	Plug
J217	1	1	1	YP10001130	Plug
J218	1	1	1	YP06000570	Plug, 3P
J221	1	1	1	YP10001130	Plug
J223	1	1	1	YP10001130	Plug
J224	1	1	1	YP10001130	Plug
J225	1	1	1	YP10001130	Plug
J226	1	1	1	YP10001130	Plug
J227	1	1	1	YP10001130	Plug
J228	1	1	1	YP10001130	Plug
J229	1	1	1	YP10001130	Plug
J231	1	1	1	YP10001130	Plug
J232	1	1	1	YP10001130	Plug
J233	1	1	1	YP10001130	Plug
J234	1	1	1	YP10001130	Plug
J235	1	1	1	YP06000570	Plug, 3P
J236	1	1	1	YP10001130	Plug
J238	1	1	1	YP10001130	Plug
J239	1	1	1	YP10001130	Plug
J240	1	1	1	YP10001130	Plug
L201	1	1	1	L114016230	I.F.T., FM
L202	1	1	1	LC12230020	Choke Coil
L203	1	1	1	LC12230020	Choke Coil
L204	1	1	1	LC13320020	Choke Coil
L205	1	1	1	LC13320020	Choke Coil

U : For U.S.A.
 C : For Canada
 E : For Europe

REF. DESIG.	Q'TY			PART NO.	DESCRIPTION
	U	C	E		
L206	1	1	1	LC13320020	Choke Coil
P200	1	1	1	YD22182060	P.W. Board, AM Tuner, FM IF & MPX Stereo Decoder
			1	ZZ22192060	P.W. Board Assembly
			1	ZZ22199060	P.W. Board Assembly
			1	ZZ22198060	P.W. Board Assembly
Q201	1	1	1	HT310471C0	Transistor, 2SC1047 C
Q202	1	1	1	HC10011060	I.C., NPC555H
Q203	1	1	1	HC10019030	I.C., LA1222
Q204	1	1	1	HT308291C0	Transistor, 2SC829 C
Q205	1	1	1	HC10019030	I.C., LA1222
Q206	1	1	1	HT308291C0	Transistor, 2SC829 C
Q207	1	1	1	HD20011050	Diode, 1S1555
Q208	1	1	1	HD20011050	Diode, 1S1555
Q209	1	1	1	HT313272A0	Transistor, 2SC1327 S or T
Q210	1	1	1	HT108422A0	Transistor, 2SA842 GR or BL
Q211	1	1	1	HT308291C0	Transistor, 2SC829 C
Q212	1	1	1	HD10003020	Diode, 20A90
Q213	1	1	1	HD10003020	Diode, 20A90
Q214	1	1	1	HD10003020	Diode, 20A90
Q215	1	1	1	HD10003020	Diode, 20A90
Q216	1	1	1	HT308291C0	Transistor, 2SC829 C
Q217	1	1	1	HD10003020	Diode, 20A90
Q218	1	1	1	HD10003020	Diode, 20A90
Q219	1	1	1	HT308291C0	Transistor, 2SC829 C
Q220	1	1	1	HD10003020	Diode, 20A90
Q221	1	1	1	HD10003020	Diode, 20A90
Q222	1	1	1	HT309452B0	Transistor, 2SC945 Q or P
Q223	1	1	1	HD10003020	Diode, 20A90
R201	1	1	1	RT05331141	Res., Fixed, 330Ω ±5%, ¼W
R202	1	1	1	RT05331140	Res., Fixed, 330Ω ±5%, ¼W
R203	1	1	1	RT05153140	Res., Fixed, 15kΩ ±5%, ¼W
R204	1	1	1	RT05202140	Res., Fixed, 2kΩ ±5%, ¼W
R205	1	1	1	RT05331140	Res., Fixed, 330Ω ±5%, ¼W
R206	1	1	1	RT05201140	Res., Fixed, 200Ω ±5%, ¼W
R207	1	1	1	RT05101140	Res., Fixed, 100Ω ±5%, ¼W
R208	1	1	1	RT05331140	Res., Fixed, 330Ω ±5%, ¼W
R209	1	1	1	RT05331140	Res., Fixed, 330Ω ±5%, ¼W
R210	1	1	1	RT05101140	Res., Fixed, 100Ω ±5%, ¼W
R211	1	1	1	RT05100140	Res., Fixed, 10Ω ±5%, ¼W
R212	1	1	1	RT05151140	Res., Fixed, 150Ω ±5%, ¼W
R213	1	1	1	RT05153140	Res., Fixed, 15kΩ ±5%, ¼W
R214	1	1	1	RT05472140	Res., Fixed, 4.7kΩ ±5%, ¼W
R215	1	1	1	RT05202140	Res., Fixed, 2kΩ ±5%, ¼W
R216	1	1	1	RT05102140	Res., Fixed, 1kΩ ±5%, ¼W
R217	1	1	1	RT05302140	Res., Fixed, 3kΩ ±5%, ¼W
R218	1	1	1	RT05102140	Res., Fixed, 1kΩ ±5%, ¼W
R219	1	1	1	RT05223140	Res., Fixed, 22kΩ ±5%, ¼W
R220	1	1	1	RT05102140	Res., Fixed, 1kΩ ±5%, ¼W
R221	1	1	1	RT05273140	Res., Fixed, 27kΩ ±5%, ¼W
R222	1	1	1	RT05274140	Res., Fixed, 270kΩ ±5%, ¼W
R223	1	1	1	RT05471140	Res., Fixed, 470Ω ±5%, ¼W
R224	1	1	1	RT05102140	Res., Fixed, 1kΩ ±5%, ¼W
R225	1	1	1	RT05202140	Res., Fixed, 2kΩ ±5%, ¼W
R226	1	1	1	RT05152140	Res., Fixed, 1.5kΩ ±5%, ¼W
R227	1	1	1	RT05101140	Res., Fixed, 100Ω ±5%, ¼W
R228	1	1	1	RT05151140	Res., Fixed, 150Ω ±5%, ¼W
R229	1	1	1	RT05271140	Res., Fixed, 270Ω ±5%, ¼W

REF. DESIG.	Q'TY			PART NO.	DESCRIPTION
	U	C	E		
R230	1	1	1	RT05102140	Res., Fixed, 1kΩ ±5%, ¼W
R231	1	1	1	RT05471140	Res., Fixed, 470Ω ±5%, ¼W
R232	1	1	1	RT05153140	Res., Fixed, 15kΩ ±5%, ¼W
R233	1	1	1	RT05242140	Res., Fixed, 2.4kΩ ±5%, ¼W
R234	1	1	1	RT05152140	Res., Fixed, 1.5kΩ ±5%, ¼W
R235	1	1	1	RT05102140	Res., Fixed, 1kΩ ±5%, ¼W
R236	1	1	1	RT05273140	Res., Fixed, 27kΩ ±5%, ¼W
R237	1	1	1	RT05154140	Res., Fixed, 150kΩ ±5%, ¼W
R238	1	1	1	RT05151140	Res., Fixed, 150Ω ±5%, ¼W
R239	1	1	1	RT05331140	Res., Fixed, 330Ω ±5%, ¼W
R240	1	1	1	RT05102140	Res., Fixed, 1kΩ ±5%, ¼W
R241	1	1	1	RT05181140	Res., Fixed, 180Ω ±5%, ¼W
R242	1	1	1	RT05101140	Res., Fixed, 100Ω ±5%, ¼W
R243	1	1	1	RT05101140	Res., Fixed, 100Ω ±5%, ¼W
R244	1	1	1	RT05561140	Res., Fixed, 560Ω ±5%, ¼W
R245	1	1	1	RT05153140	Res., Fixed, 15kΩ ±5%, ¼W
R246	1	1	1	RT05472140	Res., Fixed, 4.7kΩ ±5%, ¼W
R247	1	1	1	RT05102140	Res., Fixed, 1kΩ ±5%, ¼W
R248	1	1	1	RT05102140	Res., Fixed, 1kΩ ±5%, ¼W
R249	1	1	1	RT05273140	Res., Fixed, 27kΩ ±5%, ¼W
R250	1	1	1	RT05151140	Res., Fixed, 150Ω ±5%, ¼W
R251	1	1	1	RT05153140	Res., Fixed, 15kΩ ±5%, ¼W
R252	1	1	1	RT05822140	Res., Fixed, 8.2kΩ ±5%, ¼W
R253	1	1	1	RT05102140	Res., Fixed, 1kΩ ±5%, ¼W
R254	1	1	1	RT05821140	Res., Fixed, 820Ω ±5%, ¼W
R255	1	1	1	RT05821140	Res., Fixed, 820Ω ±5%, ¼W
R256	1	1	1	RT05682140	Res., Fixed, 6.8kΩ ±5%, ¼W
R257	1	1	1	RT05682140	Res., Fixed, 6.8kΩ ±5%, ¼W
R258	1	1	1	RT05101140	Res., Fixed, 100Ω ±5%, ¼W
R259	1	1	1	RT05562140	Res., Fixed, 5.6kΩ ±5%, ¼W
R260	1	1	1	RT05105140	Res., Fixed, 1MΩ ±5%, ¼W
R261	1	1	1	RT05224140	Res., Fixed, 220kΩ ±5%, ¼W
R262	1	1	1	RT05223140	Res., Fixed, 22kΩ ±5%, ¼W
R263	1	1	1	RT05122140	Res., Fixed, 1.2kΩ ±5%, ¼W
R264	1	1	1	RT05222140	Res., Fixed, 2.2kΩ ±5%, ¼W
R265	1	1	1	RT05561140	Res., Fixed, 560Ω ±5%, ¼W
R266	1	1	1	RT05334140	Res., Fixed, 330kΩ ±5%, ¼W
R267	1	1	1	RT05334140	Res., Fixed, 330kΩ ±5%, ¼W
R268	1	1	1	RT05564140	Res., Fixed, 560kΩ ±5%, ¼W
R269	1	1	1	RT05223140	Res., Fixed, 22kΩ ±5%, ¼W
R270	1	1	1	RT05564140	Res., Fixed, 560kΩ ±5%, ¼W
R271	1	1	1	RT05223140	Res., Fixed, 22kΩ ±5%, ¼W
R272	1	1	1	RT05221140	Res., Fixed, 220Ω ±5%, ¼W
R273	1	1	1	RT05101140	Res., Fixed, 100Ω ±5%, ¼W
R274	1	1	1	RT05101140	Res., Fixed, 100Ω ±5%, ¼W
R275	1	1	1	RT05683140	Res., Fixed, 68kΩ ±5%, ¼W
R276	1	1	1	RT05473140	Res., Fixed, 4.7kΩ ±5%, ¼W
R277	1	1	1	RT05153140	Res., Fixed, 15kΩ ±5%, ¼W
R278	1	1	1	RA01030250	Res., Semifixed, 10kΩ
R279	1	1	1	RT05102140	Res., Fixed, 1kΩ ±5%, ¼W
R280	1	1	1	RA02540010	Res., Semifixed, 250kΩ
R281	1	1	1	RT05103140	Res., Fixed, 10kΩ ±5%, ¼W
R281	1	1	1	RT05104140	Res., Fixed, 100kΩ ±5%, ¼W
R282	1	1	1	RT05153140	Res., Fixed, 15kΩ ±5%, ¼W
R283	1	1	1	RT05561140	Res., Fixed, 560Ω ±5%, ¼W
C301	1	1	1	DF55471010	Cap., Film, 470pF
C302	1	1	1	DF55911010	Cap., Film, 910pF
C303	1	1	1	DF55681010	Cap., Film, 680pF
C304	1	1	1	DF55152030	Cap., Film, 1500pF
C305	1	1	1	EA22601690	Cap., Elect., 22μF, 16V

U: For U.S.A.
C: For Canada
E: For Europe

REF. DESIG.	Q'TY			PART NO.	DESCRIPTION
	U	C	E		
C306	1	1	1	DF17473010	Cap., Film, 0.047μF
C307	1	1	1	EQ22405010	Elect., 0.22μF, 35V
C308	1	1	1	EQ47405010	Cap., Elect., 0.47μF, 35V
C309	1	1	1	EQ22405010	Cap., Elect., 0.22μF, 35V
C310	1	1	1	DF55471010	Cap., Film, 470pF
C311	1	1	1	DF15272050	Cap., Film, 2700pF
C312	1	1	1	DF15272050	Cap., Film, 2700pF
C313	1	1	1	DF15272050	Cap., Film, 2700pF
C313	1	1	1	DF15562050	Cap., Film, 5600pF
C314	1	1	1	DF15272050	Cap., Film, 2700pF
C314	1	1	1	DF15562050	Cap., Film, 5600pF
C315	1	1	1	EA10601690	Cap., Elect., 10μF, 16V
C316	1	1	1	EA10601690	Cap., Elect., 10μF, 16V
C317	1	1	1	EA10701690	Cap., Elect., 100μF, 16V
C318	1	1	1	EA10701690	Cap., Elect., 100μF, 16V
C319	1	1	1	EV10403560	Cap., Elect., 0.1μF, 35V
C320	1	1	1	EV10503560	Cap., Elect., 1μF, 35V
C321	1	1	1	EV10503560	Cap., Elect., 1μF, 35V
C322	1	1	1	EV10503560	Cap., Elect., 1μF, 35V
L301	1	1	1	LS10290160	M.P.X. Coil, Antirbirde
L302	1	1	1	LS10290170	M.P.X. Coil, Antirbirde
L303	1	1	1	LS10290180	M.P.X. Coil, Antirbirde
L304	1	1	1	LS35035010	M.P.X. Coil
Q301	1	1	1	HC10004010	I.C., HA1156 W
Q302	1	1	1	HT108422A0	Transistor, 2SA842 GR or BL
Q303	1	1	1	HT108422A0	Transistor, 2SA842 GR or BL
Q304	1	1	1	HT309452B0	Transistor, 2SC545 Q or P
Q305	1	1	1	HT107331Q0	Transistor, 2SA733 Q
Q306	1	1	1	HF200300A0	F.E.T., 2SK30
Q307	1	1	1	HT309452B0	Transistor, 2SC945 Q or P
Q308	1	1	1	HT309452B0	Transistor, 2SC945 Q or P
Q309	1	1	1	HT309452B0	Transistor, 2SC945 Q or P
Q310	1	1	1	HT309452B0	Transistor, 2SC945 Q or P
Q311	1	1	1	HT309452B0	Transistor, 2SC945 Q or P
Q312	1	1	1	HT309452B0	Transistor, 2SC945 Q or P
Q313	1	1	1	HD20011050	Diode, 1S1555
R301	1	1	1	RT05272140	Res., Fixed, 2.7kΩ ±5%, ¼W
R302	1	1	1	RT05272140	Res., Fixed, 2.7kΩ ±5%, ¼W
R303	1	1	1	RT05102140	Res., Fixed, 1kΩ ±5%, ¼W
R304	1	1	1	RT05392140	Res., Fixed, 3.9kΩ ±5%, ¼W
R305	1	1	1	RT05392140	Res., Fixed, 3.9kΩ ±5%, ¼W
R306	1	1	1	RT05102140	Res., Fixed, 1kΩ ±5%, ¼W
R307	1	1	1	RT05102140	Res., Fixed, 1kΩ ±5%, ¼W
R308	1	1	1	RT05200140	Res., Fixed, 20Ω ±5%, ¼W
R309	1	1	1	RT05163140	Res., Fixed, 16kΩ ±5%, ¼W
R310	1	1	1	RA04720050	Res., Semifixed, 4.7kΩ
R311	1	1	1	RT05272140	Res., Fixed, 2.7kΩ ±5%, ¼W
R312	1	1	1	RT05512140	Res., Fixed, 5.1kΩ ±5%, ¼W
R313	1	1	1	RT05512140	Res., Fixed, 5.1kΩ ±5%, ¼W
R314	1	1	1	RT05202140	Res., Fixed, 2kΩ ±5%, ¼W
R315	1	1	1	RT05202140	Res., Fixed, 2kΩ ±5%, ¼W
R316	1	1	1	RT05332140	Res., Fixed, 3.3kΩ ±5%, ¼W
R317	1	1	1	RT05332140	Res., Fixed, 3.3kΩ ±5%, ¼W
R318	1	1	1	RT05103140	Res., Fixed, 10kΩ ±5%, ¼W
R319	1	1	1	RA01040180	Res., Semifixed, 100kΩ
R320	1	1	1	RT05204140	Res., Fixed, 200kΩ ±5%, ¼W
R321	1	1	1	RT05303140	Res., Fixed, 30kΩ ±5%, ¼W
R322	1	1	1	RT05332140	Res., Fixed, 3.3kΩ ±5%, ¼W
R323	1	1	1	RT05332140	Res., Fixed, 3.3kΩ ±5%, ¼W
R324	1	1	1	RT05101140	Res., Fixed, 100Ω ±5%, ¼W

REF. DESIG.	Q'TY			PART NO.	DESCRIPTION
	U	C	E		
R325	1	1	1	RT05100140	Res., Fixed, 10Ω ±5%, ¼W
R325	1	1	1	RT05273140	Res., Fixed, 27kΩ ±5%, ¼W
R326	1	1	1	RT05273140	Res., Fixed, 27kΩ ±5%, ¼W
R327	1	1	1	RT05104140	Res., Fixed, 100kΩ ±5%, ¼W
R328	1	1	1	RT05104140	Res., Fixed, 100kΩ ±5%, ¼W
R329	1	1	1	RT05222140	Res., Fixed, 2.2kΩ ±5%, ¼W
R330	1	1	1	RA01030250	Res., Semifixed, 10kΩ
R331	1	1	1	RT05104140	Res., Fixed, 100kΩ ±5%, ¼W
R332	1	1	1	RT05104140	Res., Fixed, 100kΩ ±5%, ¼W
R333	1	1	1	RT05102140	Res., Fixed, 1kΩ ±5%, ¼W
R334	1	1	1	RA01040180	Res., Semifixed, 100kΩ
R335	1	1	1	RT05104140	Res., Fixed, 100kΩ ±5%, ¼W
R336	1	1	1	RT05103140	Res., Fixed, 10kΩ ±5%, ¼W
R337	1	1	1	RT05332140	Res., Fixed, 3.3kΩ ±5%, ¼W
R338	1	1	1	RT05564140	Res., Fixed, 560kΩ ±5%, ¼W
R339	1	1	1	RT05333140	Res., Fixed, 33kΩ ±5%, ¼W
R340	1	1	1	RT05101140	Res., Fixed, 100Ω ±5%, ¼W
R341	1	1	1	RT05154140	Res., Fixed, 150kΩ ±5%, ¼W
R342	1	1	1	RT05473140	Res., Fixed, 47kΩ ±5%, ¼W
R343	1	1	1	RT05224140	Res., Fixed, 220kΩ ±5%, ¼W
R344	1	1	1	RT05104140	Res., Fixed, 100kΩ ±5%, ¼W
R345	1	1	1	RT05103140	Res., Fixed, 10kΩ ±5%, ¼W
R346	1	1	1	RT05101140	Res., Fixed, 100Ω ±5%, ¼W
R347	1	1	1	RA01040180	Res., Semifixed, 100kΩ
R348	1	1	1	RT05183140	Res., Fixed, 18kΩ ±5%, ¼W
C401	1	1	1	EA10703590	Cap., Elect., 100μF, 35V
C402	1	1	1	EA10703590	Cap., Elect., 100μF, 35V
C403	1	1	1	DD15390010	Cap., Ceramic, 39pF, 50V
C404	1	1	1	DD15390010	Cap., Ceramic, 39pF, 50V
C405	1	1	1	DD15331010	Cap., Ceramic, 330pF, 50V
C406	1	1	1	DD15331010	Cap., Ceramic, 330pF, 50V
C407	1	1	1	DD15331010	Cap., Ceramic, 330pF, 50V
C408	1	1	1	DD15331010	Cap., Ceramic, 330pF, 50V
C409	1	1	1	DF14362020	Cap., Film, 3600pF, 50V
C410	1	1	1	DF14362020	Cap., Film, 3600pF, 50V
C411	1	1	1	DF14122010	Cap., Film, 1200pF, 50V
C412	1	1	1	DF14122010	Cap., Film, 1200pF, 50V
C413	1	1	1	DD11040010	Cap., Ceramic, 4pF, 50V
C414	1	1	1	DD11040010	Cap., Ceramic, 4pF, 50V
C415	1	1	1	DF16102010	Cap., Film, 1000pF, 50V
C416	1	1	1	DF16102010	Cap., Film, 1000pF, 50V
C417	1	1	1	EE47502540	Cap., Elect., 4.7μF, 25V
C418	1	1	1	EE47502540	Cap., Elect., 4.7μF, 25V
C419	1	1	1	EE47601040	Cap., Elect., 47μF, 10V
C420	1	1	1	EE47601040	Cap., Elect., 47μF, 10V
C421	1	1	1	EE47502540	Cap., Elect., 4.7μF, 25V
C422	1	1	1	EE47502540	Cap., Elect., 4.7μF, 25V
J401	1	1	1	YP06001370	Plug, 4P, Basepost
J402	1	1	1	YP06001370	Plug, 4P, Basepost
J403	1	1	1	YP06001050	Plug, 5P, Basepost
J404	1	1	1	YP06001050	Plug, 5P, Basepost
J405	1	1	1	YP06001050	Plug, 5P, Basepost
J406	1	1	1	YP06001050	Plug, 5P, Basepost
J407	1	1	1	YP10001130	Plug
J408	1	1	1	YP10001130	Plug
J409	1	1	1	YP10001130	Plug
J410	1	1	1	YP10001130	Plug
J411	1	1	1	YP10001130	Plug
J412	1	1	1	YP10001130	Plug

U: For U.S.A.
C: For Canada
E: For Europe

REF. DESIG.	Q'TY			PART NO.	DESCRIPTION
	U	C	E		
J413	1	1	1	YP10001130	Plug
J414	1	1	1	YP10001130	Plug
J415	1	1	1	YP10001130	Plug
J416	1	1	1	YP10001130	Plug
J417	1	1	1	YP10001130	Plug
J418	1	1	1	YP10001130	Plug
J419	1	1	1	YP10001130	Plug
J420	1	1	1	YP10001130	Plug
J421	1	1	1	YP10001130	Plug
J422	1	1	1	YP10001130	Plug
J423	1	1	1	YP10001130	Plug
J424	1	1	1	YP10001130	Plug
J425	1	1	1	YP10001130	Plug
J426	1	1	1	YP10001130	Plug
J427	1	1	1	YP10001130	Plug
J428	1	1	1	YP10001130	Plug
J429	1	1	1	YP10001130	Plug
J430	1	1	1	YP10001130	Plug
J431	1	1	1	YP10001130	Plug
J432	1	1	1	YP10001130	Plug
J433	1	1	1	YP10001130	Plug
J434	1	1	1	YP10001130	Plug
J435	1	1	1	YP10001130	Plug
J436	1	1	1	YP10001130	Plug
J437	1	1	1	YP10001130	Plug
J438	1	1	1	YP10001130	Plug
J439	1	1	1	YP10001130	Plug
J440	1	1	1	YP10001130	Plug
J441	1	1	1	YP10001130	Plug
J442	1	1	1	YP10001130	Plug
P400	1	1	1	YK22190230	P.W. Board, Phono Amp & Selector Switch
	1	1	1	ZZ22192040	P.W. Board Assembly
			1	ZZ22198040	P.W. Board Assembly
Q401	1	1	1	HT108412A0	Transistor, 2SA841 GR or BL
Q402	1	1	1	HT108412A0	Transistor, 2SA841 GR or BL
Q403	1	1	1	HT108412A0	Transistor, 2SA841 GR or BL
Q404	1	1	1	HT108412A0	Transistor, 2SA841 GR or BL
Q405	1	1	1	HT109122D0	Transistor, 2SA912 S or T
Q406	1	1	1	HT109122D0	Transistor, 2SA912 S or T
Q407	1	1	1	HT318852D0	Transistor, 2SC1885 S or T
Q408	1	1	1	HT318852D0	Transistor, 2SC1885 S or T
R401	1	1	1	RT05823140	Res., Fixed, 82kΩ ±5%, ¼W
R402	1	1	1	RT05823140	Res., Fixed, 82kΩ ±5%, ¼W
R403	1	1	1	RN05153140	Res., Fixed, 15kΩ ±5%, ¼W
R404	1	1	1	RN05153140	Res., Fixed, 15kΩ ±5%, ¼W
R405	1	1	1	RT05911140	Res., Fixed, 910Ω ±5%, ¼W
R406	1	1	1	RT05911140	Res., Fixed, 910Ω ±5%, ¼W
R407	1	1	1	RT05123140	Res., Fixed, 12kΩ ±5%, ¼W
R408	1	1	1	RT05123140	Res., Fixed, 12kΩ ±5%, ¼W
R409	1	1	1	RN05623140	Res., Fixed, 62kΩ ±5%, ¼W
R410	1	1	1	RN05623140	Res., Fixed, 62kΩ ±5%, ¼W
R411	1	1	1	RT02911140	Res., Fixed, 910Ω ±5%, ¼W
R412	1	1	1	RT02911140	Res., Fixed, 910Ω ±5%, ¼W
R413	1	1	1	RT02683140	Res., Fixed, 68kΩ ±5%, ¼W
R414	1	1	1	RT02683140	Res., Fixed, 68kΩ ±5%, ¼W
R415	1	1	1	RT05431140	Res., Fixed, 430Ω ±5%, ¼W
R416	1	1	1	RT05431140	Res., Fixed, 430Ω ±5%, ¼W

REF. DESIG.	Q'TY			PART NO.	DESCRIPTION
	U	C	E		
R417	1	1	1	RT02105140	Res., Fixed, 1MΩ ±2%, ¼W
R418	1	1	1	RT02105140	Res., Fixed, 1MΩ ±2%, ¼W
R419	1	1	1	RT05331140	Res., Fixed, 330Ω ±5%, ¼W
R420	1	1	1	RT05331140	Res., Fixed, 330Ω ±5%, ¼W
R421	1	1	1	RT05330140	Res., Fixed, 33Ω ±5%, ¼W
R422	1	1	1	RT05330140	Res., Fixed, 33Ω ±5%, ¼W
R423	1	1	1	RT05202140	Res., Fixed, 2kΩ ±5%, ¼W
R424	1	1	1	RT05202140	Res., Fixed, 2kΩ ±5%, ¼W
R425	1	1	1	RT05203140	Res., Fixed, 20kΩ ±5%, ¼W
R426	1	1	1	RT05203140	Res., Fixed, 20kΩ ±5%, ¼W
R427	1	1	1	RT05331140	Res., Fixed, 330Ω ±5%, ¼W
R428	1	1	1	RT05331140	Res., Fixed, 330Ω ±5%, ¼W
R429	1	1	1	RT05105140	Res., Fixed, 1MΩ ±5%, ¼W
R430	1	1	1	RT05105140	Res., Fixed, 1MΩ ±5%, ¼W
R431	1	1	1	GF05100140	Res., Fixed, 10Ω ±5%, ¼W
R432	1	1	1	GF05100140	Res., Fixed, 10Ω ±5%, ¼W
R433	1	1	1	RT05102140	Res., Fixed, 1kΩ ±5%, ¼W
R434	1	1	1	RT05102140	Res., Fixed, 1kΩ ±5%, ¼W
R435	1	1	1	RT05101140	Res., Fixed, 100Ω ±5%, ¼W
R436	1	1	1	RT05240140	Res., Fixed, 24Ω ±5%, ¼W
R437	1	1	1	RT05273140	Res., Fixed, 27kΩ ±5%, ¼W
R438	1	1	1	RT05105140	Res., Fixed, 1MΩ ±5%, ¼W
R439	1	1	1	RT05105140	Res., Fixed, 1MΩ ±5%, ¼W
S401	1	1	1	SR09060020	Rotary Switch, Selector
S401	1	1	1	SR10060140	Rotary Switch, Selector
S402	1	1	1	SR04050110	Rotary Switch, Mode
W401	1	1	1	YB00120020	Connective Cord
C701	2	2	2	DD15101010	Cap., Ceramic, 100pF, 50V
C702	2	2	2	EE47502540	Cap., Elect., 4.7μF, 25V
C703	2	2	2	DK16221510	Cap., Ceramic, 220pF, 500V
C704	2	2	2	DF17223050	Cap., Film, 0.022μF, 50V
C705	2	2	2	DD11050500	Cap., Ceramic, 5pF, 500V
C706	2	2	2	DK16101500	Cap., Ceramic, 100pF, 500V
C708	2	2	2	DF17224050	Cap., Film, 0.22μF, 50V
C710	2	2	2	DF17104520	Cap., Film, 0.1μF, 200V
C711	2	2	2	DF16103050	Cap., Film, 0.01μF, 50V
C712	2	2	2	DF16103050	Cap., Film, 0.01μF, 50V
C713	2	2	2	DF16104050	Cap., Film, 0.1μF, 50V
C714	2	2	2	DF16104050	Cap., Film, 0.1μF, 50V
C716	2	2	2	DF17104520	Cap., Film, 0.1μF, 200V
C717	2	2	2	DF17104520	Cap., Film, 0.1μF, 200V
C718	2	2	2	DF17104520	Cap., Film, 0.1μF, 200V
C719	2	2	2	DF17104520	Cap., Film, 0.1μF, 200V
C720	2	2	2	EA47505090	Cap., Elect., 4.7μF, 50V
C721	2	2	2	EA10605090	Cap., Elect., 10μF, 50V
C722	2	2	2	EE10701640	Cap., Elect., 100μF, 16V
C723	2	2	2	EA10601690	Cap., Elect., 10μF, 16V
C724	2	2	2	EA10601690	Cap., Elect., 10μF, 16V
C725	2	2	2	EA22601090	Cap., Elect., 22μF, 10V
J701	2	2	2	YP10001430	Plug, 3P
J702	2	2	2	YP06001300	Plug, 6P
J703	2	2	2	YJ06001330	Jack, 8P
J704	2	2	2	YJ06001340	Jack, 4P
J705	2	2	2	YJ06001340	Jack, 4P
J706	2	2	2	YL09010130	Terminal, 1P
J707	2	2	2	YL09010130	Terminal, 1P
J708	2	2	2	YL09010140	Terminal, 1P
J709	2	2	2	YL09010140	Terminal, 1P
L701	2	2	2	LC22220010	Choke Coil
L702	2	2	2	LC22220010	Choke Coil

U: For U.S.A.
C: For Canada
E: For Europe

REF. DESIG.	Q'TY			PART NO.	DESCRIPTION
	U	C	E		
P700	2	2	2	YG22190010 ZZ22192010	P.W. Board, Main Amp P.W. Board Assembly
Q701	2	2	2	HT320882A0	Transistor, 2SC2088 BL or V
Q702	2	2	2	HT320882A0	Transistor, 2SC2088 BL or V
Q703	2	2	2	HT320882A0	Transistor, 2SC2088 BL or V
Q704	2	2	2	HT107332B0	Transistor, 2SA733 Q or R
Q705	2	2	2	HT109392B0	Transistor, 2SA939 B or V
Q706	2	2	2	HT109392B0	Transistor, 2SA939 B or V
Q707	2	2	2	HT320712B0	Transistor, 2SC2071 B or V
Q708	2	2	2	HT320712B0	Transistor, 2SC2071 B or V
Q709	2	2	2	HT309452A0	Transistor, 2SC945 Q or R
Q710	2	2	2	HT107332B0	Transistor, 2SA733 Q or R
Q711	2	2	2	HT320713A0	Transistor, 2SC2071 G, B or V
Q712	2	2	2	HT109393A0	Transistor, 2SA939 G, B or V
Q713	2	2	2	HT107502B0	Transistor, 2SA750 E or U
Q714	2	2	2	HT107502B0	Transistor, 2SA750 E or U
Q715	2	2	2	HD20001210	Diode, 1S2473
Q716	2	2	2	HD20001210	Diode, 1S2473
Q717	2	2	2	HV00003120	Varistor, MV-13
Q718	2	2	2	HD20003210	Diode, 1S2471
Q719	2	2	2	HD20001210	Diode, 1S2473
Q720	2	2	2	HD20001210	Diode, 1S2473
Q721	2	2	2	HD20001210	Diode, 1S2473
Q722	2	2	2	HD20001210	Diode, 1S2473
Q723	2	2	2	HD20001210	Diode, 1S2473
Q724	2	2	2	HD20003210	Diode, 1S2471
Q725	2	2	2	HD20003210	Diode, 1S2471
Q726	2	2	2	HD20001210	Diode, 1S2473
Q727	2	2	2	HD20001210	Diode, 1S2473
Q728	2	2	2	HD20011010	Diode, W06C
Q729	2	2	2	HD20011010	Diode, W06C
Q730	2	2	2	HD30023090	Zener, WZ-071, 7.1V 0.5W
Q731	2	2	2	HD30002130	Zener, EQA01-35R, 35V 0.5W
Q732	2	2	2	HD20001210	Diode, 1S2473
Q733	2	2	2	HD30027090	Zener, WZ-140, 14V 0.5W
Q734	2	2	2	HD20001210	Diode, 1S2473
Q735	2	2	2	HD20001210	Diode, 1S2473
R701	2	2	2	RT05513140	Res., Fixed, 51kΩ ±5%, ¼W
R702	2	2	2	RT05182140	Res., Fixed, 1.8kΩ ±5%, ¼W
R703	2	2	2	RT05514140	Res., Fixed, 510kΩ ±5%, ¼W
R704	2	2	2	RT05432140	Res., Fixed, 4.3kΩ ±5%, ¼W
R705	2	2	2	RT05432140	Res., Fixed, 4.3kΩ ±5%, ¼W
R706	2	2	2	RT05681140	Res., Fixed, 680Ω ±5%, ¼W
R707	2	2	2	RT05511140	Res., Fixed, 510Ω ±5%, ¼W
R708	2	2	2	RT05822140	Res., Fixed, 8.2kΩ ±5%, ¼W
R709	2	2	2	GF05472120	Res., Fixed, 4.7kΩ ±5%, ¼W
R710	2	2	2	RT05184140	Res., Fixed, 180kΩ ±5%, ¼W
R711	2	2	2	RT05184140	Res., Fixed, 180kΩ ±5%, ¼W
R712	2	2	2	RT05182140	Res., Fixed, 1.8kΩ ±5%, ¼W
R713	2	2	2	RT05393140	Res., Fixed, 39kΩ ±5%, ¼W
R714	2	2	2	RT05183140	Res., Fixed, 18kΩ ±5%, ¼W
R715	2	2	2	RT05154140	Res., Fixed, 150kΩ ±5%, ¼W
R716	2	2	2	RT05513140	Res., Fixed, 51kΩ ±5%, ¼W
R717	2	2	2	RT05511140	Res., Fixed, 510Ω ±5%, ¼W
R718	2	2	2	RT05511140	Res., Fixed, 510Ω ±5%, ¼W
R719	2	2	2	RT05511140	Res., Fixed, 510Ω ±5%, ¼W
R720	2	2	2	RT05511140	Res., Fixed, 510Ω ±5%, ¼W
R721	2	2	2	RT05181140	Res., Fixed, 180Ω ±5%, ¼W
R722	2	2	2	GJ05030010	Res., Fixed, 3Ω ±5%, 1W
R723	2	2	2	RT05153140	Res., Fixed, 15kΩ ±5%, ¼W

REF. DESIG.	Q'TY			PART NO.	DESCRIPTION
	U	C	E		
R724	2	2	2	RT05153140	Res., Fixed, 15kΩ ±5%, ¼W
R725	2	2	2	RT05393140	Res., Fixed, 39kΩ ±5%, ¼W
R726	2	2	2	GF05100120	Res., Fixed, 10Ω ±5%, ¼W
R727	2	2	2	GF05100120	Res., Fixed, 10Ω ±5%, ¼W
R728	2	2	2	GF05100140	Res., Fixed, 10Ω ±5%, ¼W
R729	2	2	2	GF05100140	Res., Fixed, 10Ω ±5%, ¼W
R730	2	2	2	RT05301140	Res., Fixed, 300Ω ±5%, ¼W
R731	2	2	2	RT05301140	Res., Fixed, 300Ω ±5%, ¼W
R732	2	2	2	GF05161140	Res., Fixed, 160Ω ±5%, ¼W
R733	2	2	2	GF05161140	Res., Fixed, 160Ω ±5%, ¼W
R734	2	2	2	GF05201140	Res., Fixed, 200Ω ±5%, ¼W
R735	2	2	2	GF05201140	Res., Fixed, 200Ω ±5%, ¼W
R736	2	2	2	GF05273120	Res., Fixed, 27kΩ ±5%, ¼W
R737	2	2	2	GF05561120	Res., Fixed, 560Ω ±5%, ¼W
R738	2	2	2	GJ05151010	Res., Fixed, 150Ω ±5%, 1W
R739	2	2	2	GJ05022030	Res., Fixed, 2.2Ω ±5%, 3W
R740	2	2	2	GW10392050	Res., Fixed, 0.39Ω ±10%, 5W
R741	2	2	2	GW10392050	Res., Fixed, 0.39Ω ±10%, 5W
R742	2	2	2	GW10392050	Res., Fixed, 0.39Ω ±10%, 5W
R743	2	2	2	GW10392050	Res., Fixed, 0.39Ω ±10%, 5W
R744	2	2	2	GW10392050	Res., Fixed, 0.39Ω ±10%, 5W
R745	2	2	2	GW10392050	Res., Fixed, 0.39Ω ±10%, 5W
R746	2	2	2	GW10392050	Res., Fixed, 0.39Ω ±10%, 5W
R747	2	2	2	GW10392050	Res., Fixed, 0.39Ω ±10%, 5W
R748	2	2	2	GJ05047030	Res., Fixed, 4.7Ω ±5%, 3W
R749	2	2	2	GJ05047030	Res., Fixed, 4.7Ω ±5%, 3W
R750	2	2	2	RT05220140	Res., Fixed, 22Ω ±5%, ¼W
R751	2	2	2	RT05470140	Res., Fixed, 47Ω ±5%, ¼W
R752	2	2	2	RT05470140	Res., Fixed, 47Ω ±5%, ¼W
R753	2	2	2	RT05102140	Res., Fixed, 1kΩ ±5%, ¼W
R754	2	2	2	RT05102140	Res., Fixed, 1kΩ ±5%, ¼W
R755	2	2	2	GJ05822010	Res., Fixed, 8.2kΩ ±5%, 1W
R756	2	2	2	GJ05123010	Res., Fixed, 12kΩ ±5%, 1W
R757	2	2	2	RT05033140	Res., Fixed, 3.3Ω ±5%, ¼W
R758	2	2	2	RT05151140	Res., Fixed, 150Ω ±5%, ¼W
R759	2	2	2	RT05154140	Res., Fixed, 150kΩ ±5%, ¼W
R760	2	2	2	RA02220090	Res., Semifixed, 2.2kΩ
R761	2	2	2	RA01020270	Res., Semifixed, 1kΩ
W701	2	2	2	YB00090010	Connective Cord
C801	1	1	1	DF17103510	Cap., Film, 200V DC
C802	1	1	1	DF17103510	Cap., Film, 200V DC
C803	1	1	1	DF17103050	Cap., Film, 0.01μF, 50V
C804	1	1	1	DF17103050	Cap., Film, 0.01μF, 50V
C805	1	1	1	DF17103050	Cap., Film, 0.01μF, 50V
C806	1	1	1	DF17103050	Cap., Film, 0.01μF, 50V
C807	1	1	1	EA22625010	Cap., Elect., 22μF, 250V
C808	1	1	1	EA10625010	Cap., Elect., 10μF, 250V
C809	1	1	1	EB10806310	Cap., Elect., 1000μF, 63V
C810	1	1	1	EB47706320	Cap., Elect., 470μF, 63V
C811	1	1	1	EA10635010	Cap., Elect., 10μF, 350V
C812	1	1	1	EA10635010	Cap., Elect., 10μF, 350V
C813	1	1	1	EA22701690	Cap., Elect., 220μF, 16V
C814	1	1	1	EA22701690	Cap., Elect., 220μF, 16V
C815	1	1	1	EA10705090	Cap., Elect., 10μF, 50V
C816	1	1	1	EA22705090	Cap., Elect., 220μF, 50V
C817	1	1	1	EA22705090	Cap., Elect., 220μF, 50V
C818	1	1	1	EA10601690	Cap., Elect., 10μF, 16V
C819	1	1	1	EE47505040	Cap., Elect., 4.7μF, 50V
C820	1	1	1	EE47505040	Cap., Elect., 4.7μF, 50V
F801	1	1	1	FS10200060	Fuse, 30mm(UL)

U: For U.S./
C: For Canada
E: For Europe

REF. DESIG.	Q'TY			PART NO.	DESCRIPTION
	U	C	E		
F801			1	FS10200800	Fuse, 20mm (SEMKO)
F802	1	1		FS10050090	Fuse, 30mm (UL)
F802			1	FS10200800	Fuse, 20mm (SEMKO)
F803	1	1		FS10050090	Fuse, 30mm (UL)
F803			1	FS10200800	Fuse, 20mm (SEMKO)
F804	1	1		FS10050090	Fuse, 30mm (UL)
F804			1	FS10200800	Fuse, 20mm (SEMKO)
F805	1	1		FS10050090	Fuse, 30mm (UL)
F805			1	FS10200800	Fuse, 20mm (SEMKO)
F806	1	1		FS10150050	Fuse, 30mm (UL)
F806			1	FS10200800	Fuse, 20mm (SEMKO)
F807	1	1		FS10150050	Fuse, 30mm (UL)
F807			1	FS10200800	Fuse, 20mm (SEMKO)
J801	1	1		YP06000830	Plug, 4P, Basepost
J802	1	1		YP06000840	Plug, 6P, Basepost
J803	1	1		YP06001040	Plug, 3P, Basepost
J804	1	1		YP06001310	Plug, 6P, Basepost
J805	1	1		YP06001050	Plug, 5P, Basepost
J806	1	1		YJ08000200	Jack, Fuse Holder
J806			1	YJ08000210	Jack, Fuse Holder
J807	1	1		YJ08000200	Jack, Fuse Holder
J807			1	YJ08000210	Jack, Fuse Holder
J808	1	1		YJ08000200	Jack, Fuse Holder
J808			1	YJ08000210	Jack, Fuse Holder
J809	1	1		YJ08000200	Jack, Fuse Holder
J809			1	YJ08000210	Jack, Fuse Holder
J810	1	1		YJ08000200	Jack, Fuse Holder
J810			1	YJ08000210	Jack, Fuse Holder
J811	1	1		YJ08000200	Jack, Fuse Holder
J811			1	YJ08000210	Jack, Fuse Holder
J812	1	1		YJ08000200	Jack, Fuse Holder
J812			1	YJ08000210	Jack, Fuse Holder
J813	1	1		YJ08000200	Jack, Fuse Holder
J813			1	YJ08000210	Jack, Fuse Holder
J814	1	1		YJ08000200	Jack, Fuse Holder
J814			1	YJ08000210	Jack, Fuse Holder
J815	1	1		YJ08000200	Jack, Fuse Holder
J815			1	YJ08000210	Jack, Fuse Holder
J816	1	1		YJ08000200	Jack, Fuse Holder
J816			1	YJ08000210	Jack, Fuse Holder
J817	1	1		YJ08000200	Jack, Fuse Holder
J817			1	YJ08000210	Jack, Fuse Holder
J818	1	1		YJ08000200	Jack, Fuse Holder
J818			1	YJ08000210	Jack, Fuse Holder
J819	1	1		YJ08000200	Jack, Fuse Holder
J819			1	YJ08000210	Jack, Fuse Holder
P800	1	1		YG22190020	P.W. Board, Power Supply
P800			1	ZZ22192030	P.W. Board Assembly
P800	1	1		YG22190030	P.W. Board, Power Supply
P800			1	ZZ22192050	P.W. Board Assembly
Q801	1	1		HT403132A0	Transistor, 2SD313 D or E
Q802	1	1		HT403132A0	Transistor, 2SD313 D or E
Q803	1	1		HT309452A0	Transistor, 2SC945 Q or R
Q804	1	1		HT108412A0	Transistor, 2SA841 GR or BL
Q805	1	1		HT403132A0	Transistor, 2SC313 D or E
Q806	1	1		HT107332A0	Transistor, 2SA733 Q or R
Q807	1	1		HD20021100	Diode, 2DL15, 1500V 0.2A
Q808	1	1		HD20014030	Diode, DS130YA, 800V 1A

REF. DESIG.	Q'TY			PART NO.	DESCRIPTION
	U	C	E		
Q809	1	1		HD20014030	Diode, DS130YA, 800V 1A
Q810	1	1		HD20011030	Diode, DS131B, 200V
Q811	1	1		HD20012030	Diode, DS132B, 200V
Q812	1	1		HD20001210	Diode, 1S2473, 35V
Q813	1	1		HD30027090	Zener, WZ-140, 14V
Q814	1	1		HD30027090	Zener, WZ-140, 14V
Q815	1	1		HD30027090	Zener, WZ-140, 14V
R801	1	1		GF05472120	Res., Fixed, 4.7kΩ ±5%, ¼W
R802	1	1		GF05100120	Res., Fixed, 10Ω ±5%, ¼W
R803	1	1		GJ05152010	Res., Fixed, 1.5kΩ ±5%, 1W
R804	1	1		GF05100120	Res., Fixed, 10Ω ±5%, ¼W
R805	1	1		GF05220140	Res., Fixed, 22Ω ±5%, ¼W
R806	1	1		GJ05222010	Res., Fixed, 2.2kΩ ±5%, 1W
R807	1	1		GQ10101070	Res., Fixed, 100Ω ±10%, 7W
R808	1	1		RT05472140	Res., Fixed, 4.7kΩ ±5%, ¼W
R809	1	1		RT05472140	Res., Fixed, 4.7kΩ ±5%, ¼W
R810	1	1		GF05202140	Res., Fixed, 2kΩ ±5%, ¼W
R811	1	1		RT05123140	Res., Fixed, 12kΩ ±5%, ¼W
R812	1	1		RT05103140	Res., Fixed, 10kΩ ±5%, ¼W
R813	1	1		RT05472140	Res., Fixed, 4.7kΩ ±5%, ¼W
R814	1	1		RT05472140	Res., Fixed, 4.7kΩ ±5%, ¼W
R815	1	1		RT05163140	Res., Fixed, 16kΩ ±5%, ¼W
R816	1	1		RT05133140	Res., Fixed, 13kΩ ±5%, ¼W
R817	1	1		RT05272140	Res., Fixed, 2.7kΩ ±5%, ¼W
R818	1	1		RT05562140	Res., Fixed, 5.6kΩ ±5%, ¼W
R819	1	1		RA04720060	Res., Semifixed, 4.7kΩ (B)
C901	1	1		DK18103820	Cap., Ceramic, 0.01μF, 1kV
C902	1	1		OK18103820	Cap., Ceramic, 0.01μF, 1kV
C903	1	1		DF17473520	Cap., Film, 0.047μF, 200V
J901	1	1		YJ06001290	Jack, 8P
J902	1	1		YP06001050	Plug, 5P, Basepost
J903	1	1		YP06001050	Plug, 5P
J904	1	1		YB00140030	Connective Cord
J905	1	1		YB00180010	Connective Cord
J906	1	1		YB00140030	Connective Cord
J907	1	1		YB00120010	Connective Cord
J908	1	1		YB00140040	Connective Cord
J909	1	1		YB00150010	Connective Cord
J910	1	1		YB00180020	Connective Cord
J911	1	1		YB00200290	Connective Cord
J912	1	1		YB00180030	Connective Cord
J913	1	1		YB00210010	Connective Cord
J914	1	1		YJ06001310	Jack, 6P
K901	1	1		HM003019A0	Transistor, 2SK30A
P900	1	1		YK22190310	P.W. Board, Scope Amp
P900			1	ZZ22190310	P.W. Board Assembly
Q901	1	1		HF200304A0	F.E.T., 2SK30A OB, OC, OD or OE
Q902	1	1		HF200304A0	F.E.T., 2SK30A OB, OC, OD or OE
Q903	1	1		HF200304A0	F.E.T., 2SK30A OB, OC, OD or OE
Q904	1	1		HF200304A0	F.E.T., 2SK30A OB, OC, OD or OE
Q905	1	1		HT31756280	Transistor, 2SC1756 D or E
Q906	1	1		HT31756280	Transistor, 2SC1756 D or E
Q907	1	1		HT31756280	Transistor, 2SC1756 D or E
Q908	1	1		HT31756280	Transistor, 2SC1756 D or E

A.
ada
pe

U: For U.S.A
C: For Canad
E: For Europ

REF. DESIG.	QTY			PART NO.	DESCRIPTION
	U	C	E		
Q909	1	1	1	HD20003210	Diode, 1S2471 70V
Q910	1	1	1	HD20003210	Diode, 1S2471 70V
Q911	1	1	1	HD20001210	Diode, 1S2473 35V
R901	1	1	1	RT05224140	Res., Fixed, 220kΩ±5%, ¼W
R902	1	1	1	RT05224140	Res., Fixed, 220kΩ±5%, ¼W
R903	1	1	1	RT05224140	Res., Fixed, 220kΩ±5%, ¼W
R904	1	1	1	RT05224140	Res., Fixed, 220kΩ±5%, ¼W
R905	1	1	1	RT05682140	Res., Fixed, 6.8kΩ±5%, ¼W
R906	1	1	1	RT05682140	Res., Fixed, 6.8kΩ±5%, ¼W
R907	1	1	1	RT05472140	Res., Fixed, 4.7kΩ±5%, ¼W
R908	1	1	1	RT05472140	Res., Fixed, 4.7kΩ±5%, ¼W
R909	1	1	1	RT05103140	Res., Fixed, 10kΩ±5%, ¼W
R910	1	1	1	RT05103140	Res., Fixed, 10kΩ±5%, ¼W
R911	1	1	1	RT05103140	Res., Fixed, 10kΩ±5%, ¼W
R912	1	1	1	RT05103140	Res., Fixed, 10kΩ±5%, ¼W
R913	1	1	1	RT05683140	Res., Fixed, 68kΩ±5%, ¼W
R914	1	1	1	RT05683140	Res., Fixed, 68kΩ±5%, ¼W
R915	1	1	1	RT05623140	Res., Fixed, 62kΩ±5%, ¼W
R916	1	1	1	RT05623140	Res., Fixed, 62kΩ±5%, ¼W
R917	1	1	1	RT05823140	Res., Fixed, 82kΩ±5%, ¼W
R918	1	1	1	RT05204140	Res., Fixed, 200kΩ±5%, ¼W
R919	1	1	1	RT05105140	Res., Fixed, 1MΩ±5%, ¼W
R920	1	1	1	RT05105140	Res., Fixed, 1MΩ±5%, ¼W
R921	1	1	1	RT05224140	Res., Fixed, 220kΩ±5%, ¼W
R922	1	1	1	RT05154140	Res., Fixed, 1.5MΩ±5%, ¼W
R923	1	1	1	RT05153140	Res., Fixed, 15kΩ±5%, ¼W
R924	1	1	1	RT05473140	Res., Fixed, 47kΩ±5%, ¼W
R925	1	1	1	RA05020130	Res., Semifixed, 4.7kΩ
R926	1	1	1	RA05020130	Res., Semifixed, 4.7kΩ
R927	1	1	1	RA01020150	Res., Semifixed, 1kΩ
R928	1	1	1	RA01020150	Res., Semifixed, 1kΩ
R929	1	1	1	RT05204140	Res., Fixed, 200kΩ±5%, ¼W
R930	1	1	1	RT05152140	Res., Fixed, 1.5kΩ±5%, ¼W
R931	1	1	1	RA01030070	Res., Semifixed, 10kΩ
R932	1	1	1	RT05473140	Res., Fixed, 47kΩ±5%, ¼W

13. TECHNICAL SPECIFICATIONS

AMPLIFIER SECTION:

Rated Power Output, Minimum Continuous Average Power per Channel, both Channels Driven	250 W
Power Band	20 Hz to 20 kHz
Total Harmonic Distortion	0.05%
Load Impedance	8 ohms
Rated Power Output, Minimum Continuous Average Power per Channel, both Channels Driven	330 W
Power Band	20 Hz to 20 kHz
Total Harmonic Distortion	0.08%
Load Impedance	4 ohms
I.M. Distortion	
(i.H.F. method, 60 Hz and 7 kHz mixed 4:1 at rated power output)	
at 8 ohm load impedance	0.05%
at 4 ohm load impedance	0.08%
Damping Factor (at 20 Hz)	60
Sensitivity (at MAIN IN)	1.5 V
Impedance (at MAIN IN)	40 kohms
Frequency Response for Power Amp Only	
(at 1 Watt output, 20 Hz to 20 kHz)	±0.2 dB

PREAMPLIFIER SECTION:

Phono	
Input Overload at 1 kHz	200 mV
Equivalent Input Noise	1.0 μV
Dynamic Range	
(Dynamic Range is the ratio of input overload to equivalent input noise.)	106 dB
Input Sensitivity	1.8 mV
Input Impedance	47 kohms
Input Capacitance	100 pF
Frequency Response, RIAA 20 Hz to 20 kHz	±0.2 dB
Signal-to-Noise Ratio	
(at rated output and 7.75 mV input)	80 dB
High Level (Aux and Tape)	
Input Sensitivity	180 mV
Input Impedance	40 kohms
Frequency Response	
(includes power amp)	10 Hz to 60 kHz, ±1.0 dB
Signal-to-Noise Ratio	
(ref. to rated output and 775 mV input)	98 dB
Output Levels	
Tape Out (ref. 7.75 mV at Phono inputs)	775 mV
Pre-Out (ref. 180 mV at Aux inputs)	1.5 V
(ref. 500 mV at Aux inputs, main amp disconnected)	4.2 V
Output Impedance	
Tape Out	500 ohms
Pre Out	450 ohms

FM TUNER SECTION:

Sensitivity	
IHF Usable	8.75 dBf (1.5 μV)
IHF 50 dB Quieting (Mono)	12.1 dBf (2.2 μV)
(Stereo)	33.2 dBf (25 μV)
Quieting Slope (Mono)	
RF Input for 30 dB Quieting	6.8 dBf (1.2 μV)
Quieting at:	
20 dBf (5.5 μV)	60 dB
25 dBf (10 μV)	66 dB
40 dBf (55 μV)	78 dB
65 dBf (1000 μV)	82 dB

Quieting Slope (Stereo)	
Quieting at:	
30 dBf (17 μ V)	49 dB
40 dBf (55 μ V)	62 dB
50 dBf (173 μ V)	70 dB
65 dBf (1000 μ V)	75 dB
Distortion (Mono) at 65 dBf (1000 μ V)	
100 Hz	0.15%
1000 Hz	0.1%
6000 Hz	0.15%
Distortion (Stereo) at 65 dBf (1000 μ V)	
100 Hz	0.35%
1000 Hz	0.2%
6000 Hz	0.3%
Distortion (Mono and Stereo)	
at 50 dB Quieting, 1000 Hz	0.4%
Hum and Noise	
at 65 dBf (1000 μ V)	
Mono	80 dB
Frequency Response	
30 Hz to 15 kHz	
Mono	+0.2 dB, -1.0 dB
Stereo	+0.2 dB, -1.0 dB
Capture Ratio at 65 dBf (1000 μ V)	1.0 dB
Alternate Channel Selectivity	85 dB
Spurious Response Rejection	120 dB
Image Response Rejection	120 dB
I.F. Rejection (Balanced)	120 dB
A.M. Suppression	60 dB
Stereo Separation	
100 Hz	45 dB
1000 Hz	50 dB
10 kHz	42 dB
Subcarrier Rejection	75 dB
AM TUNER SECTION:	
IHF Usable Sensitivity	10 μ V
Distortion (THD), 30% Modulation	0.4%
Signal-to-Noise Ratio	55 dB
Alternate Channel Selectivity	50 dB
Image Rejection	80 dB
Spurious Response Rejection	80 dB
I.F. Rejection	80 dB
GENERAL:	
Power Requirements	120 V AC, 60 Hz (for U.S.A. and Canada)
Power Consumption at rated output, both channels operating	110/120/220/240 V AC, 50 Hz (for Europe)
Idling Power (Volume Control at zero)	920 W
Dimensions:	115 W
Panel Width	490 mm (19-1/4")
Panel Height	177 mm (7")
Depth	438 mm (17-1/4")
Weight:	
Unit alone	27 kg (59.4 lbs)
Packed for Shipment	29 kg (63.8 lbs)

