

# marantz.

**SERVICE  
MANUAL**

# MODEL 240

*Stereo Power Amplifier*

# TABLE OF CONTENTS

SECTION	PAGE
Introduction	1
Circuit Description	1
General	1
Amplifier	1
Rectifier-Relay	4
Technical Specifications	5
Performance Verification	8
Alignment Procedure	11
Trouble Analysis	16
Parts List	17
Schematic	20
100, 220-Volt Conversion	22

# LIST OF ILLUSTRATIONS

FIGURE	PAGE
1. Amplifier Simplified Schematic	2
2. Rectifier/Relay Board Simplified Schematic	4
3. AC Power Control Box Schematic	7
4. Amplifier Output Load Box Schematic	7
5. Test Equipment Set-Up	8
6. Power Amplifier Heatsink Assembly	12
7. Amplifier Board, Component Side	12
8. Amplifier Board, Circuit Side	13
9. Rectifier-Relay Board, Component Side	14
10. Rectifier-Relay Board, Circuit Side	15
11. Model 240 Schematic	20

TABLE	PAGE
1. Recommended Test Equipment	6

## INTRODUCTION

This service manual is intended for use by authorized warranty stations. The manual contains service information for the Marantz Model 240 Stereo Power Amplifier, manufactured by the Marantz Company, a subsidiary of Superscope Incorporated, Chatsworth, California 91311

Adjustment, maintenance, and troubleshooting information listed herein should be attempted only by the experienced technician, one knowledgeable in solid state amplifier operation and the use of test equipment. All instructions should be read carefully and understood fully before proceeding with any service.

Symptoms (and their remedies) listed in the troubleshooting section, are those which might occur in some units. As the Marantz Company becomes aware of other field problems, supplementary service bulletins will be issued to all stations. To improve this service, all problems (and their solutions) not covered in this service manual should be brought to the attention of the National Service Manager at our Sun Valley location.

## CIRCUIT DESCRIPTION

### GENERAL

This section is included to assist the service technician in understanding the operation of the Model 240 Stereo Power Amplifier. It is intended to describe, on a technical level, the basic operating principles of the Model 240. The following circuit description will be based on the left channel only. The right channel operates in an identical manner.

### AMPLIFIER

The input stage of the power amplifier, fig. 1, is comprised of an emitter-follower, Q519, and its current source, Q518. The output of this stage is coupled through C502 and R506 to the differential amplifier (Q501, Q502), which drives an inverter (Q503) whose collector current is developed through current source Q504. The inverter is coupled to complementary pre-drivers (Q507, Q508). The output of the pre-drivers is applied to their respective drivers (Q510, Q511) which are coupled to their respective power transistors (Q802, Q804 – Q803, Q805).

Output current regulation is accomplished through a current-sensing network. Excessive current levels are detected by resistors R531 and R532. Voltages developed across these resistors are applied to current sensors Q516 and Q517.

When excessive current levels are detected, Q516 and Q517 develop peak-limiting signals, which are applied to Q505 and Q506. These transistors disable the pre-drivers on excessive output current peaks, thus limiting peak output current to a safe level.

Feedback for the amplifier is developed at the junction of R531 and R532. The feedback is applied across two loops. Feedback applied across R520 and C509 completes the driver-power output loop. Feedback applied across R519 and C508 completes the loop for the entire power amplifier.



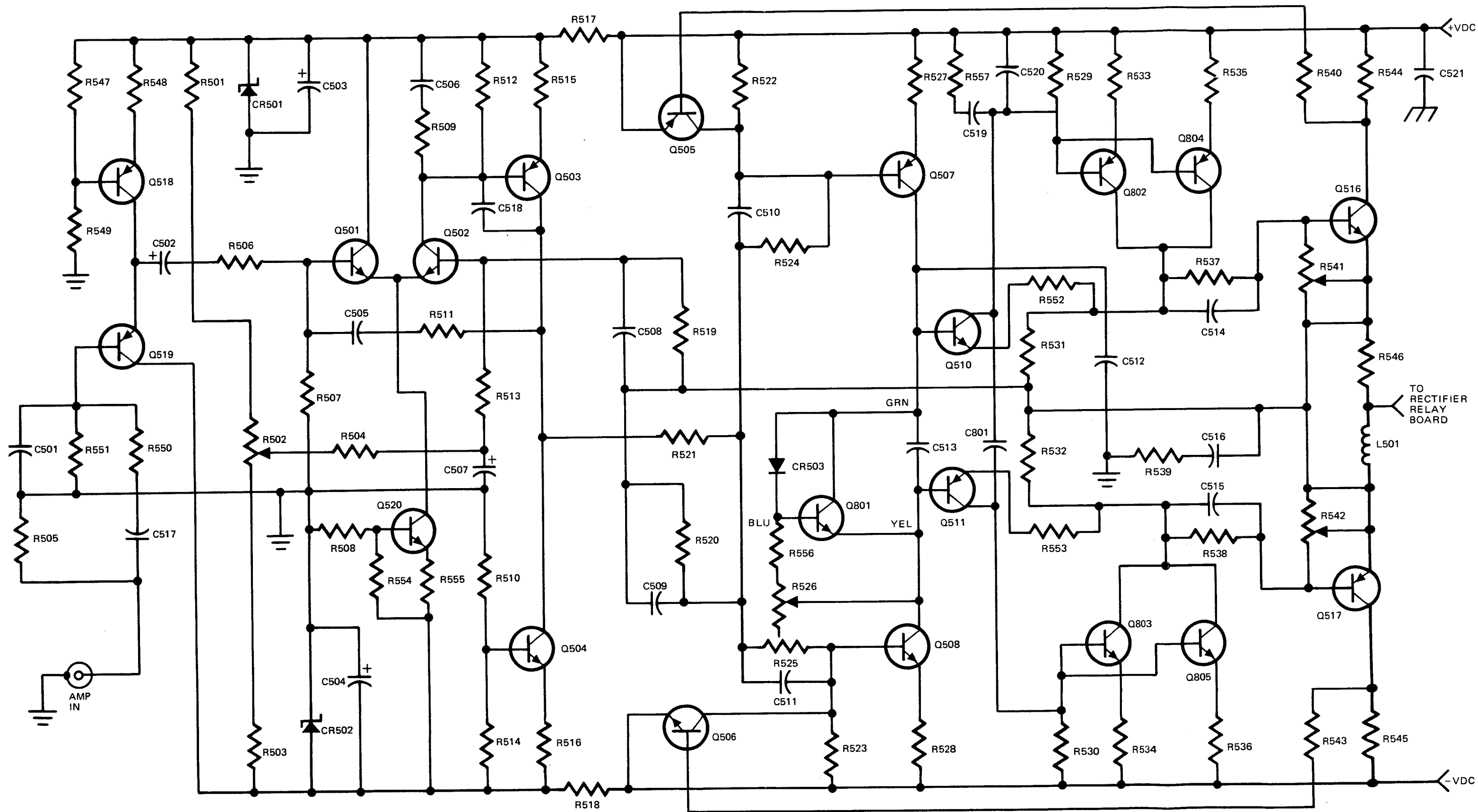

FIGURE 1. AMPLIFIER SIMPLIFIED SCHEMATIC

## RECTIFIER RELAY BOARD

The output of the power amplifier is applied to the wipers of relay K301 on the rectifier relay board, Figure 2. Relay K301 energizes after a minimum delay of two seconds after turn on. The length of the delay is a factor of the time constant of R306, R309, and C302. This delay at turn-on is to prevent any transient surges from reaching the output terminals. Additionally, resistors R302 and R305 sample the audio output signals. Should a constant DC level over +4.5 volts, or a high amplitude signal below 10 Hz be present, Q301 will turn on, shorting the base of Q303 to ground. C302 begins to discharge and K301 de-energizes. If a constant DC level over -4.5 volts is present, the voltage drop across R304 bucks the voltage present at the base of Q303 and K301 de-energizes. The output from K301 is applied to the SPEAKER TERMINALS.

86-1/2 volts AC is applied to CR301 through CR304 which develop the +58 and -58 volts for the power amplifier board. CR305 and CR306 develop the positive voltage to energize K301.

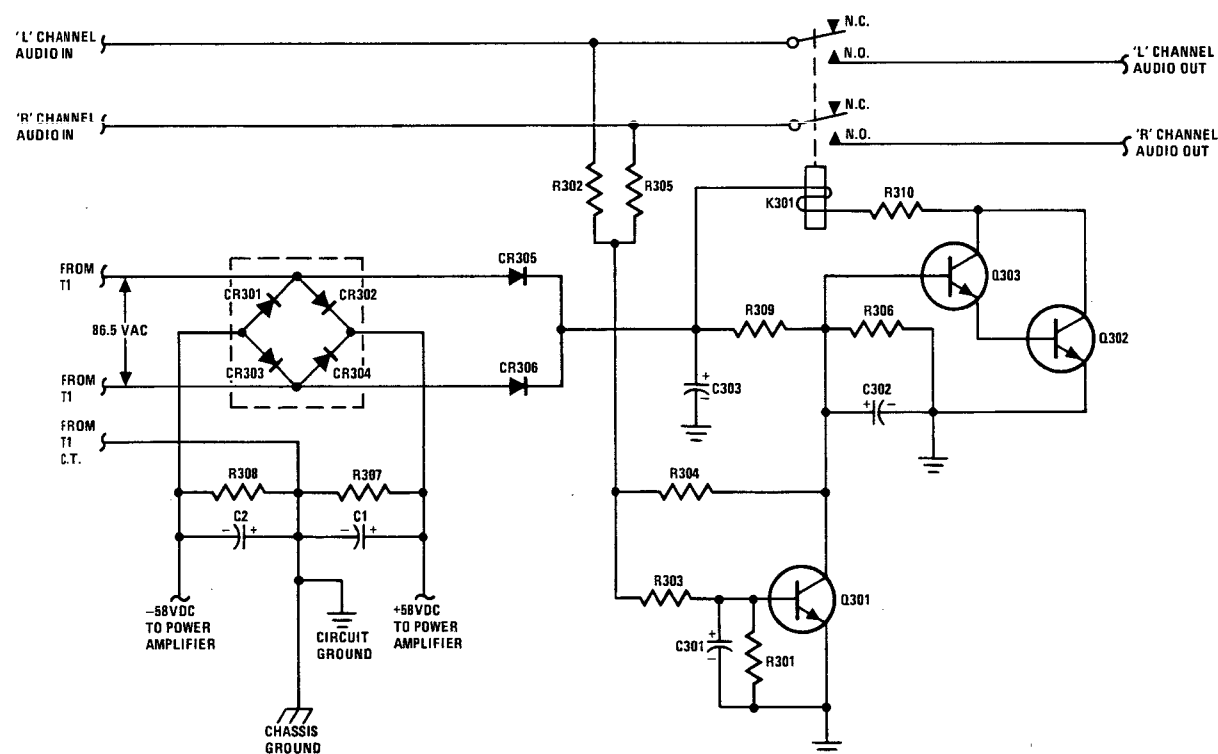

FIGURE 2. RECTIFIER/RELAY BOARD SIMPLIFIED SCHEMATIC

## TECHNICAL SPECIFICATIONS

Power Output (each channel, both channels driven, at rated distortion, 20 Hz to 20 KHz)

Load	RMS
4 ohms	150W
8 ohms	120W
16 ohms	60W

Total Harmonic Distortion (at or below rated power, 20 Hz to 20 KHz) . . . . . Less than 0.1%

Intermodulation Distortion (at or below rated power, SMPTE, any combination of two frequencies, 20 Hz to 20 KHz). . . . . Less than 0.1%

Frequency Response

2 Hz to 100 KHz . . . . .	+0, -1.5 dB
20 Hz to 20 KHz . . . . .	+0, -0.5 dB

Input Sensitivity (for rated power) . . . . . 1.5 volts

Input Impedance . . . . . 100K ohms

Damping Factor (at 8 ohms) . . . . . Greater than 100

### GENERAL

Total Noise (into 8 ohms) . . . . . Better than 106 dB below rated power

Power Requirements\* . . . . . 120 vac, 480W, 50/60 Hz

Dimensions . . . . . 15-3/8" wide x 6-1/8" high x 9-1/2" deep

Unit Weight . . . . . 26 pounds

Shipping Weight . . . . . 32 pounds

\*Split primary windings permit easy conversion from 120 volt to 220 or 100 volt operation

# RECOMMENDED TEST EQUIPMENT

The test equipment listed below is recommended for servicing the Model 240 Stereo Power Amplifier. The Performance Verification and Alignment Procedure sections of this manual are based on the use of these items or their equivalent.

TABLE 1		
Item	Manufacturer and Model Number	Use
AC Wattmeter	Simpson Model 390	Monitors primary power consumption of amplifier
Line Voltmeter (0-150 vac)	Commercial Grade	Monitors potential of primary power to amplifier
Variable Autotransformer (0-140 vac, 10 amps)	Powerstat Model 116B	Controls level of primary power to amplifier
Above items to be assembled per Figure 3 as AC Power Control Box		
AC Ammeter (0-10 amps)	Commercial Grade	Monitors amplifier output under short circuit conditions
Output Load Resistor (8 $\Omega$ $\pm$ 0.5%, 250W) 2 Required	Commercial Grade	Provides 8-ohm load for amplifier output termination
Output Load Resistor (4 $\Omega$ $\pm$ 5%, 250W) 2 Required	Commercial Grade	Provides 4-ohm load for amplifier output termination
Output Load Capacitor (0.5 mfd, 300V) 2 Required	Mylar	Provides capacitive load for instability checks
Above items to be assembled per Figure 4 as Amplifier Output Load Box		
Distortion Analyzer	Hewlett Packard Model 331A or 333A	Measures distortion and voltage of amplifier output
Audio Oscillator	Weston Model CVO-100P (Note: Less than 0.02% residual distortion is required)	Sinewave signal source
Oscilloscope	Tektronix Model 503 or Data Model 555	Waveform analysis
VTVM	RCA Senior Volt-Ohmyst Model WV-98C	Voltage and resistance measurements
Shorting Plug	Use phono plug with 600 ohms across center pin and shell	Shorts amplifier input to eliminate noise pickup
Above items are assembled per Figure 5 or as directed in Test or Alignment Procedures		
Power Supply Bleeder Resistor (10 $\Omega$ , 1W)	Commercial Grade	Discharges power supply filter capacitors prior to disassembly or resistance measurements

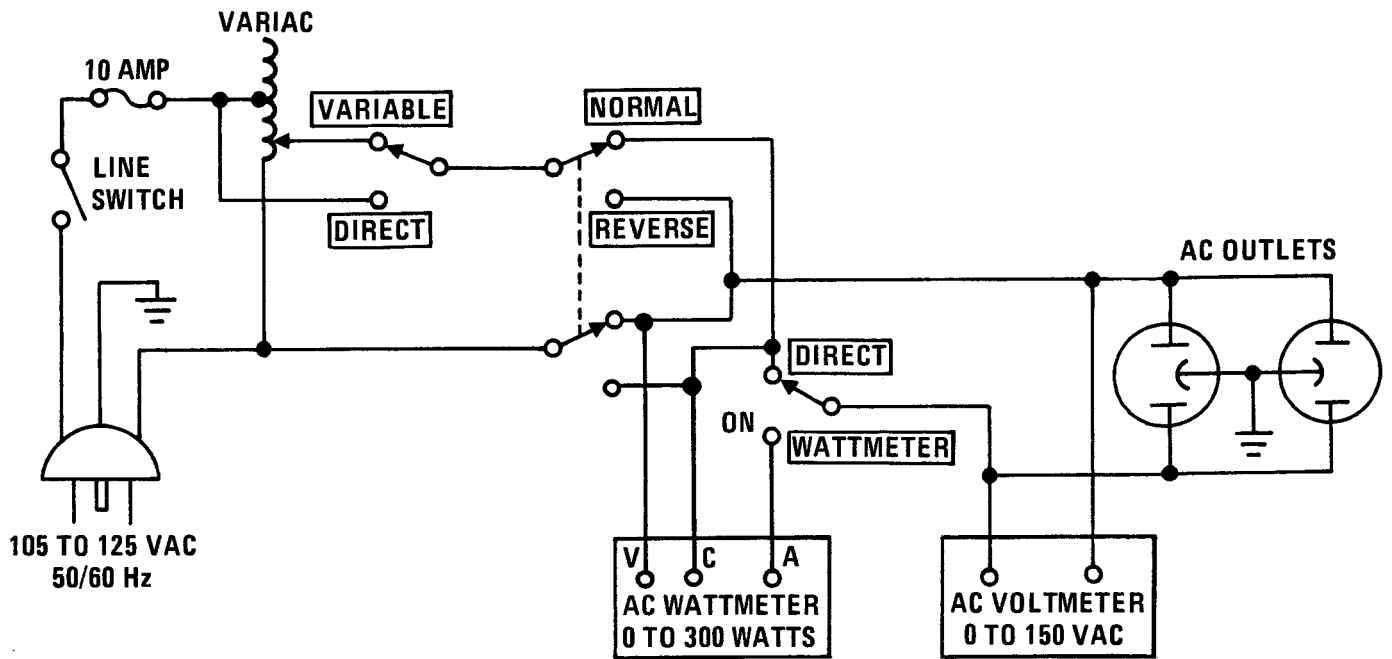

FIGURE 3. AC POWER CONTROL BOX SCHEMATIC

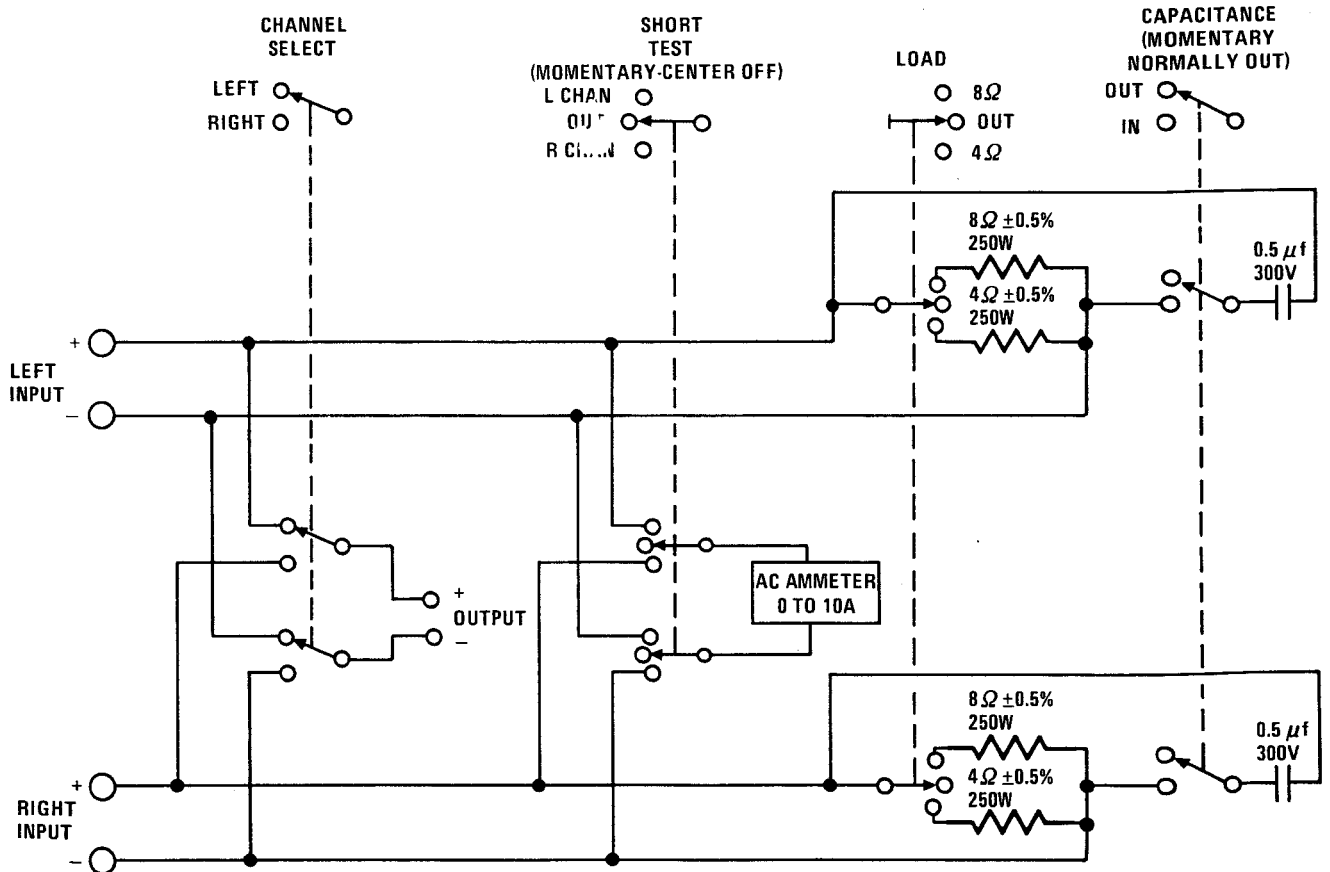

FIGURE 4. AMPLIFIER OUTPUT LOAD BOX SCHEMATIC

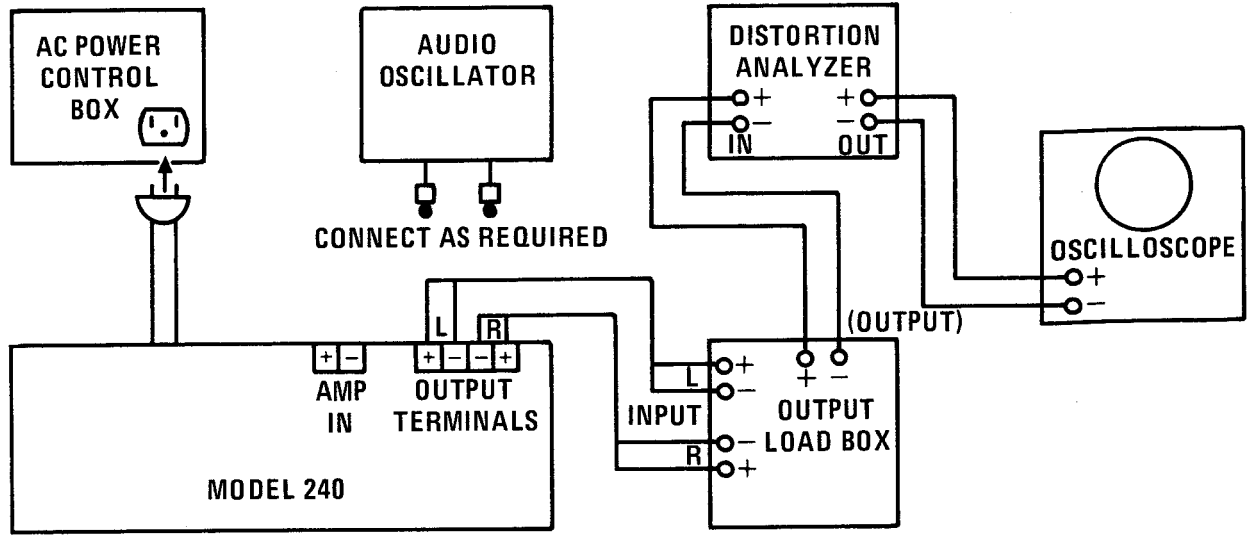

FIGURE 5. TEST EQUIPMENT SET-UP

# PERFORMANCE VERIFICATION

## TEST PROCEDURE

All tests outlined below should be performed after any repair or adjustment. The tests described in paragraphs C through H may also be used as a method of isolating the defect prior to service. Should the results of the tests be other than as specified, refer to the Alignment Procedure and/or the Trouble Analysis section of this manual. Unless otherwise specified, all tests are to be performed on both audio channels, with the results specified applying equally to each channel.

### A. Test Equipment

Refer to Table 1 for list of recommended test equipment.

### B. Preliminary Procedures

1. All tests are performed with the unit under test and the test equipment connected as shown in Figure 5. Except for the IDLING POWER test, all tests are conducted with 120 vac line voltage applied to unit. Unless otherwise speci-

fied in the procedure, the test equipment controls will be set in the following position:

#### AC Power Control Box:

- Line Switch . . . . . ON
- Wattmeter Switch . . . . . DIRECT
- Variac . . . . . 120 VAC LINE

#### Amplifier Output Load Box:

- Channel Select . SET FOR CHANNEL UNDER TEST
- Short Switch (momentary) . . . . . CENTER (OFF)
- Load Switch . . . . . AS REQUIRED BY TEST
- Capacitance Switch . . . . . OUT

2. Connections, between the output terminals of the Model 240 and the Output Load Box, must have negligible resistance with respect to the resistance of the load itself. Appreciable resistance adds to the total load, resulting in inaccurate measurement of output power.



**C. Idling Power**

1. With the Line Switch OFF, the Variac set to 0 (fully CCW) and the Wattmeter Switch to WATTMETER, plug the unit line cord into the AC Power Control Box.
2. On the Amplifier Output Load Box, set the Load Switch to OUT.
3. Turn the Line Switch ON and slowly advance the Variac while observing the Voltmeter and Wattmeter on the Power Control Box. When the line voltage reaches 120 vac, the Wattmeter should indicate between 35 and 55 watts.
4. If the Wattmeter reading is greater than 55 watts for any static Variac position, do not further increase the AC voltage. Turn off the unit and refer to the Trouble Analysis section of this manual.

**D. Relay Operation**

1. Set Line Switch to OFF. Wait approximately 30 seconds.
2. Switch line ON. Time the delay between power turn-on and the moment that the relay energizes (signaled by an audible click within the amplifier). The elapsed time should be between 2 and 10 seconds.
3. Connect the Audio Oscillator to the input jacks of both channels. Adjust frequency to 5 Hz and set level to minimum. Switch in the 8 ohm load.
4. Slowly increase the Oscillator level until the relay de-energizes, carefully observing the highest voltage reached prior to relay cut-off. The output voltage should be between 25.5 and 33.5 volts.

**E. DC Balance**

1. With the Load Switch on the Amplifier Output Load Box set to OUT, connect a VTVM (set in the DC MODE) to the output terminals of the Load Box.
2. Allow the unit to reach operating temperature (approximately 2 minute warm-up).
3. Check each channel for a DC voltage of  $0V \pm 50$  mV

**CAUTION:** THE OUTPUT VOLTAGE MAY BE AS HIGH AS  $\pm 60V$  IN A UNIT WITH MULTIPLE OPERATING DEFECTS.

**F. Total Hum and Noise Test**

1. Set the Load Switch on the Amplifier Output Load Box to OUT. With a shorting plug in each input jack of the amplifier, the output voltage should be 0.25 mV or less for each channel.
2. If output voltage is greater than 0.25 mV on either channel, reverse the AC line polarity (NORMAL-REVERSE switch on AC Power Control Box). If meter reading still exceeds 0.25 mV on either, or both channels, refer to the Trouble Analysis section.

**G. Maximum Power Output**

1. Connect the Audio Oscillator to the input jacks of both channels, with frequency set to 2 KHz and the level set to minimum. Switch in the 4 ohm load.
2. Advance the Oscillator level until the positive and negative waveforms just begin to clip. The output voltage should be  $25.5V \pm 1V$ .
3. Change the load to 8 OHMS.
4. Set the Audio Oscillator level for 31.0 volts output. Verify that neither channel is clipping.
5. Change Audio Oscillator frequency to 20 Hz and re-adjust level (if necessary) for 31.0V output. Verify lack of clipping on both channels.
6. Adjust Oscillator frequency to 20 KHz and re-set level (if required) for 31.0V output. Neither channel should be clipping.

**H. Harmonic Distortion Test**

1. Connect the Audio Oscillator to both channels and set the frequency to 20 Hz. Switch in the 8 ohm load.
2. Set the Oscillator level for 31.0 volts output. The distortion should measure less than 0.1%.
3. Change the Oscillator frequency to 20 KHz and re-adjust the level (if necessary) for 31.0V output. The measured distortion should be less than 0.1%.
4. Switch the Output Load Capacitance to IN. Verify the lack of parasitic oscillation. The distortion should be less than 0.15%.

**J. Short Circuit Test**

**CAUTION:** DO NOT PERFORM THIS TEST IF THE AMPLIFIER SHOWS ANY SIGN OF PARASITIC OSCILLATION (SEE HARMONIC DISTORTION TEST).

1. With the Audio Oscillator connected to the input jacks of both channels, set the Oscillator frequency to 200 Hz. Adjust the level for 31.6V output into an 8 ohm load.
2. Short the output of each channel with an ammeter ("SHORT TEST" switch on Load Box).  

NOTE: The output terminals should not remain shorted for more than 3 seconds.
3. The ammeter reading should be 8 Amps  $\pm 1$  Amp.

**K. Frequency Response Test**

1. Connect the Audio Oscillator to both channel input jacks. Switch in the 8 ohm load. Adjust Oscillator frequency to 2 KHz and set level for 30V output.
2. Sweep Oscillator frequency from 20 Hz to 20 KHz. The output voltage of each channel should remain within the range of 29.7 and 30.0 volts.

**L. Gain Test**

1. Apply a 1 KHz signal to the input jack of the left channel. With an 8 ohm load,

adjust the oscillator level for any convenient output voltage (between 20 and 30V).

2. Measure the input voltage level. The difference between the input and output signal levels should be 26.3 dB  $\pm 0.5$  dB.
3. Repeat for right channel.

**M. Gain Differential Test**

1. Apply an identical 1 KHz signal to the inputs of each channel. Set the oscillator level for any convenient output voltage (between 20 and 30V) into the 8 ohm load.
2. Verify that both channels have the same output voltage within 0.5 dB.

**N. Channel Separation Test**

1. Apply the output of the Audio Oscillator to the left channel input jack. Insert a shorting plug in the right channel input jack.
2. With the Load Box set for an 8 ohm load, set the Oscillator frequency to 20 KHz and the Oscillator level for a convenient output voltage (between 20 and 30 volts).
3. Measure the output voltage of the right channel and verify that it is 55 dB or more below the level of the driven channel.
4. Repeat test for left channel output with right channel driven.

# ALIGNMENT PROCEDURE

## A. Test Equipment

Refer to Table 1 for recommended test equipment.

## B. Preliminary Procedures

The preliminary procedures outlined in the Performance Verification section of this manual are applicable in their entirety. Refer to Figure 7 for component location.

## C. Unit Disassembly

1. Remove the top cover of the Model 240. The top cover is secured by 12 #6-32 x ¼" long screws.
2. Remove the left and right channel power amplifier heatsinks from the chassis, leaving all wires connected. Each heatsink is held in place by 2 screws from the rear apron, 3 screws from the chassis bottom and 2 screws into the front apron.

## D. Bias Adjust

1. Turn Line Switch to OFF. With the component side of the amplifier board face up, rotate the bias adjust potentiometer, R526, on each amplifier board fully CCW.
2. Switch the Wattmeter IN and set the Variac to 0.
3. Turn the Line Switch ON and slowly advance the Variac to 120 vac while observing the Wattmeter. The Wattmeter should indicate less than 35W. (If the Wattmeter indicates either 0 or greater than 35W, a defect exists. Turn the Line Switch OFF and refer to the Trouble Analysis section of this manual.)
4. With a shorting plug in the right channel input jack, apply a 20 KHz signal to the left channel input. With 120V line voltage, set the oscillator level for 3.1V output into the 8-ohm load.

5. Adjust R526 on the left channel amplifier board until the cross-over spikes just disappear into the base line on the scope. Verify that the power consumption of the unit did not increase more than 10 watts from previous reading.

6. Change input to right channel. Repeat steps 4 and 5 for R526 on right channel amplifier board.

## E. DC Balance Adjust

1. Monitor the output of the left channel with a VTVM (DC mode).
2. Adjust the DC Balance potentiometer, R502, on the left channel amplifier board, for an indication of "line zero" (i.e., 0V  $\pm$ 25 mV) as indicated on the oscilloscope.
3. Repeat for right channel.

**NOTE:** If this adjustment is made before the unit has reached operating temperature, the DC balance should be verified after the unit is warm, and readjusted if necessary.

## F. Maximum Power Output Adjust

1. Set the Audio Oscillator frequency to 2 KHz and adjust the level to minimum. Apply the output of the oscillator to the input jacks of both channels. Set the Load Box for a 4-ohm load.
2. Set potentiometers R541 and R542 fully CCW.
3. Increase the level of the oscillator until the output voltage reaches 25.5 volts.
4. Monitoring the output of the left channel on the oscilloscope, adjust R541, on the left channel amplifier board, until the positive peak of the waveform just begins to clip.
5. Adjust R542, on the same board, until the negative peak just begins to clip.
6. Repeat for right channel.

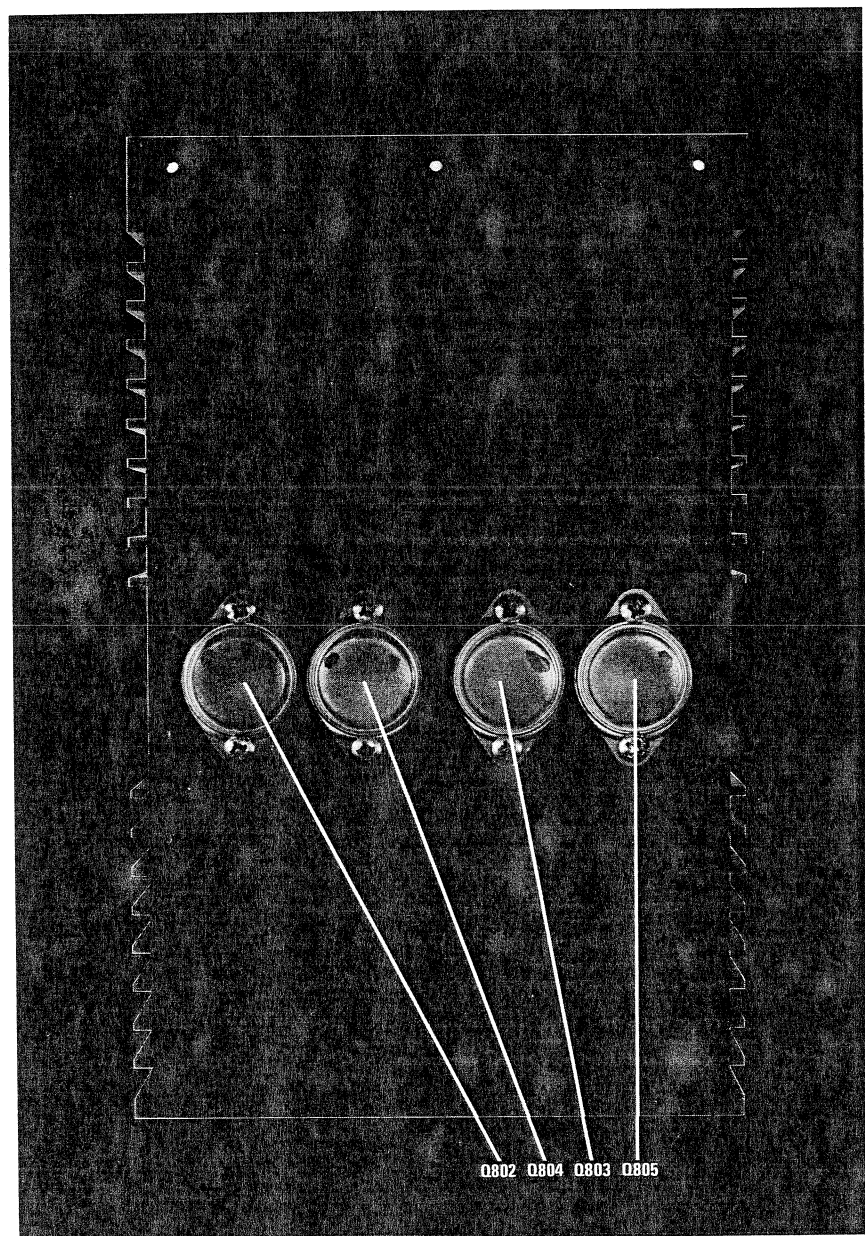

FIGURE 6. POWER AMPLIFIER HEATSINK ASSEMBLY

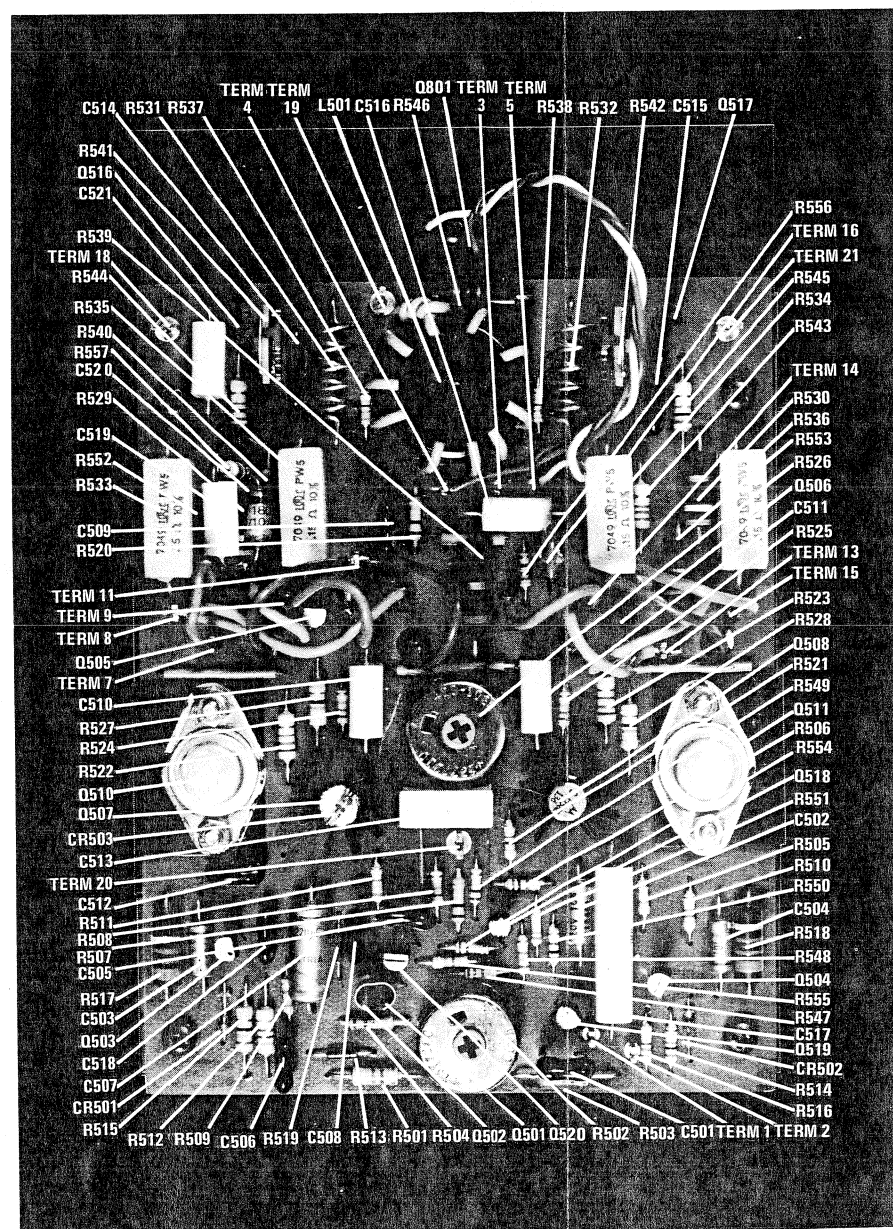

FIGURE 7. AMPLIFIER BOARD, COMPONENT SIDE

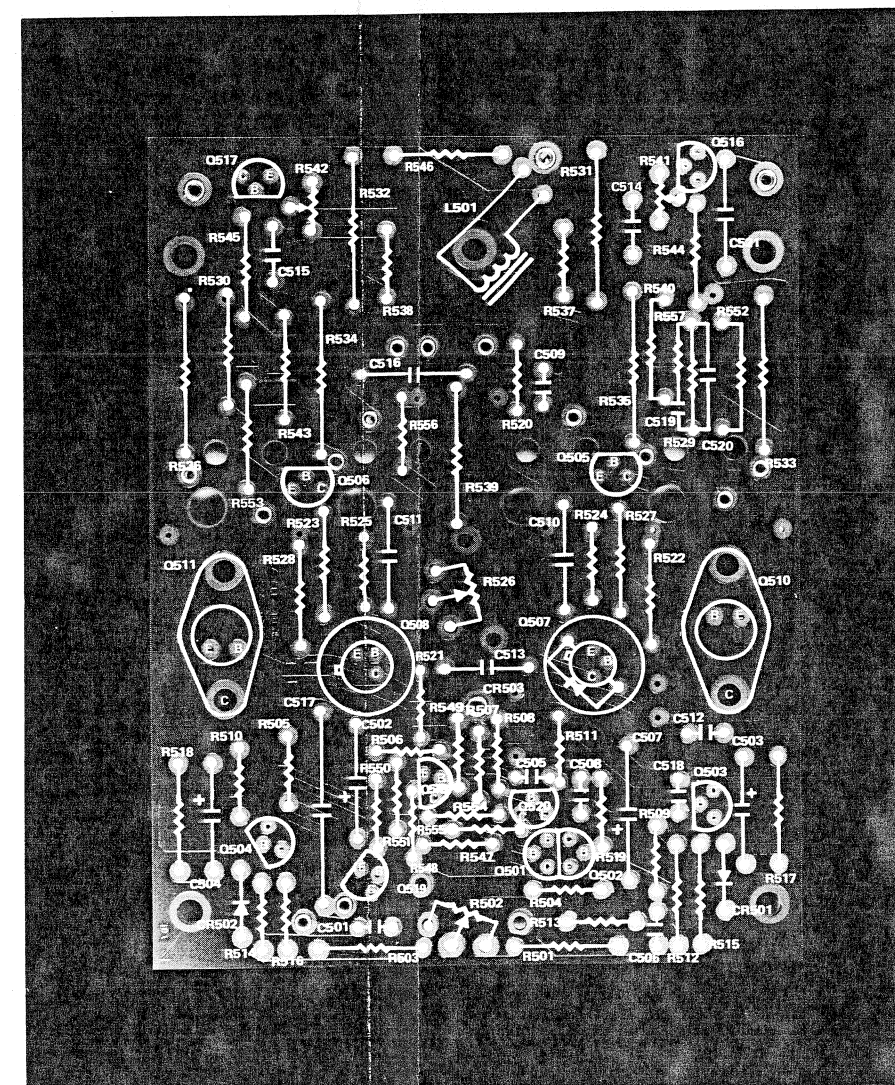

FIGURE 8. AMPLIFIER BOARD, CIRCUIT SIDE



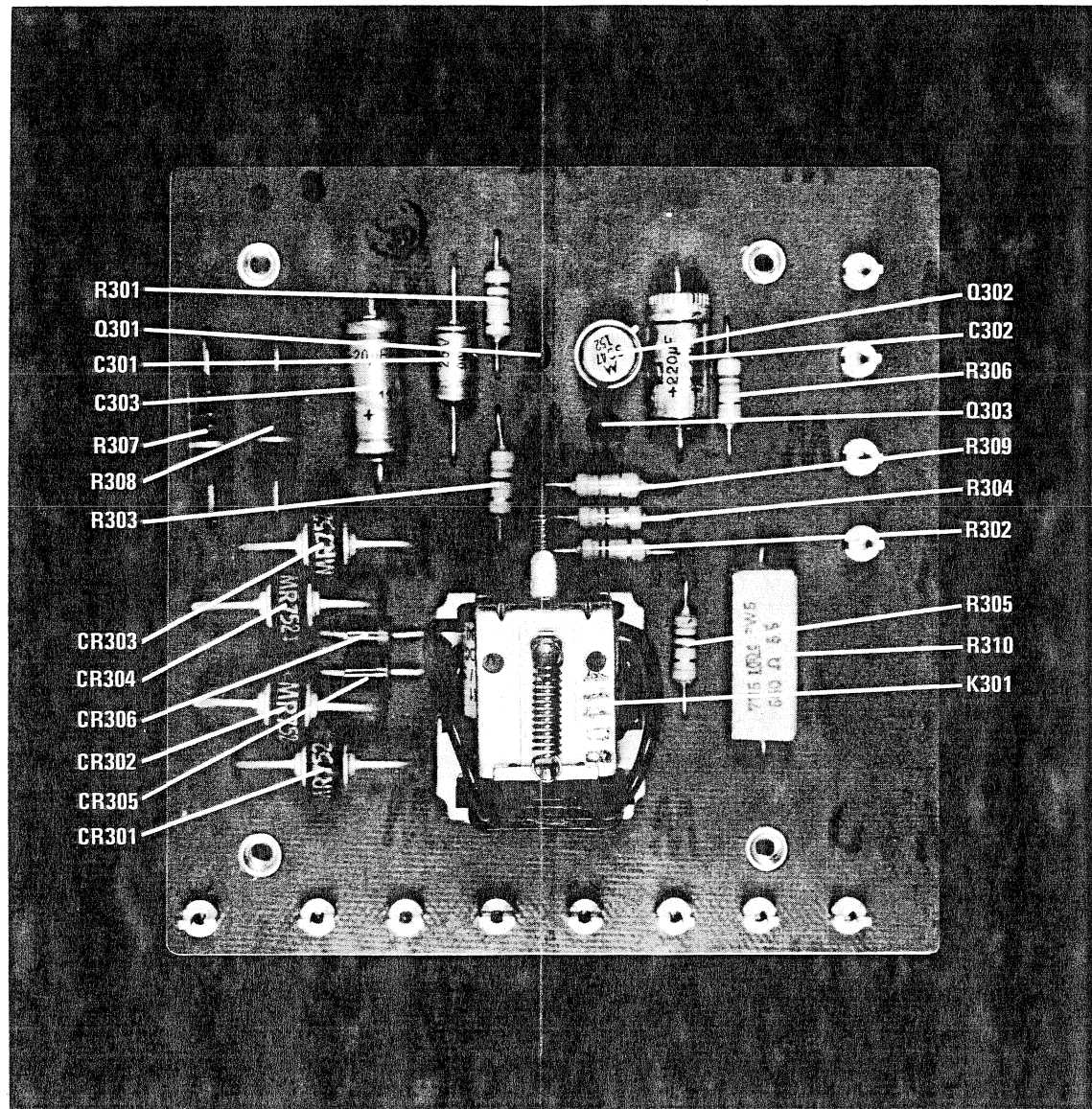

FIGURE 9. RECTIFIER-RELAY BOARD, COMPONENT SIDE

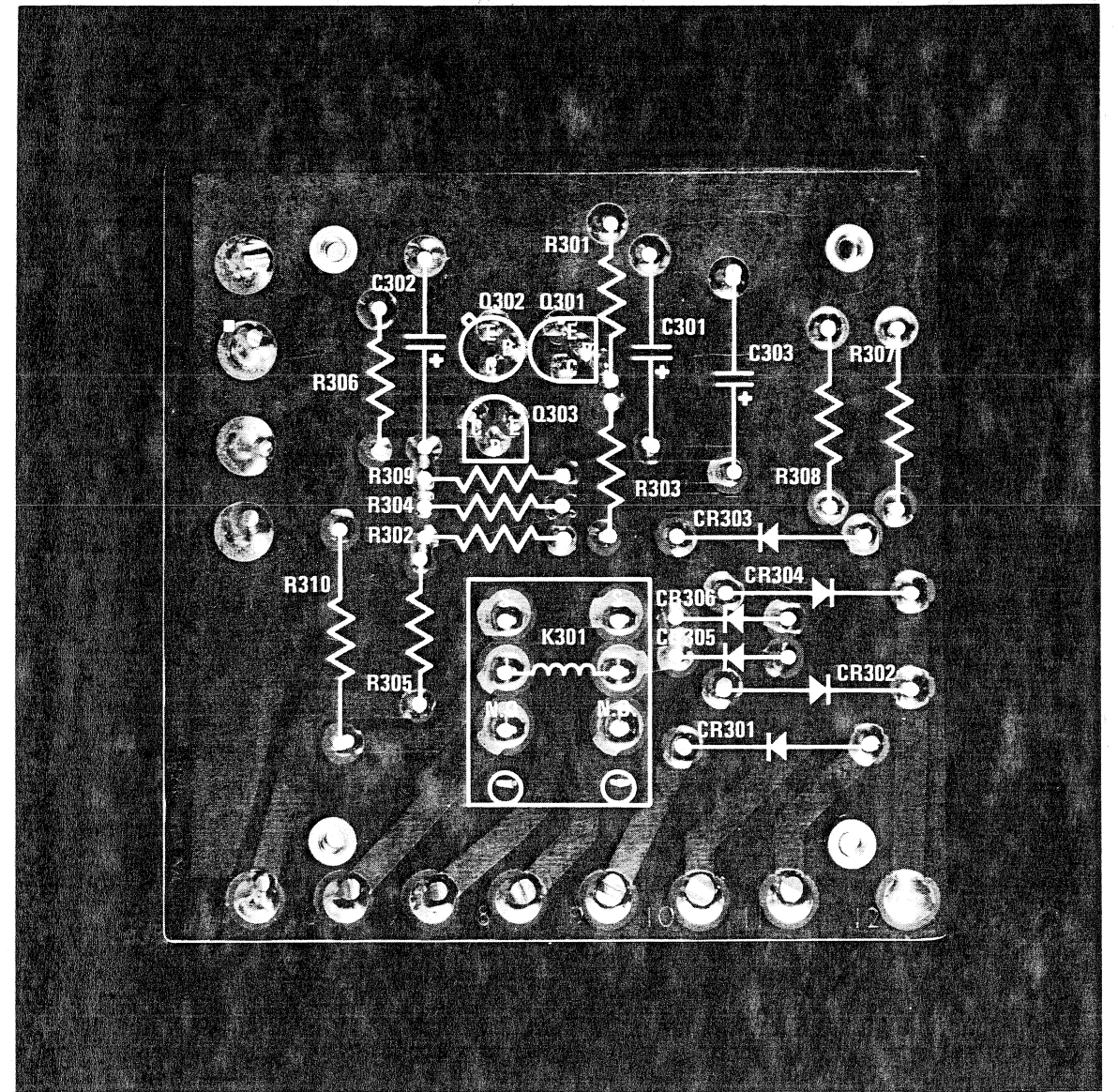

FIGURE 10. RECTIFIER-RELAY BOARD, CIRCUIT SIDE



# TROUBLE ANALYSIS

This section is a partial list of possible problems and causes that may be found in a defective Model 240. It is not the intent of this section to indicate all potential problems and their remedies since the service technician will be quite capable of recognizing most. The intent is to provide information covering those situations where problems may be difficult to isolate. It is assumed that normal troubleshooting techniques (i.e., point-to-point signal tracing, oscilloscope analysis, etc.) will be employed before referring to this section.

Any field problems that arise will be covered through service bulletins (supplementary to this manual) that will be issued to all service stations.

All references in this section will be made to Figure 11, Model 240 Schematic.

## SYMPTOM

## PROBABLE CAUSE

- |                                                                                                                                                                                                                                                                                                                                                                                                                                                                                                  |                                                                                                                                                                                                                                                                                                                                             |
|--------------------------------------------------------------------------------------------------------------------------------------------------------------------------------------------------------------------------------------------------------------------------------------------------------------------------------------------------------------------------------------------------------------------------------------------------------------------------------------------------|---------------------------------------------------------------------------------------------------------------------------------------------------------------------------------------------------------------------------------------------------------------------------------------------------------------------------------------------|
| 1. No Primary Power Consumptom                                                                                                                                                                                                                                                                                                                                                                                                                                                                   | <ul style="list-style-type: none"> <li>a. Open AC Input circuit; Line cord, fuse, etc.</li> <li>b. Open transistors Q507, Q508, Q510, Q511, Q802 through Q805.</li> <li>c. Open Bias Control, R526.</li> <li>d. Open rectifiers, CR301 through CR306, or open transformer, T1.</li> <li>e. Shorted Bias Assembly P/N 215-1006-1.</li> </ul> |
| 2. Excessive Primary Power Consumption                                                                                                                                                                                                                                                                                                                                                                                                                                                           | <ul style="list-style-type: none"> <li>a. Short in AC input circuit; transformer, line cord, etc.</li> <li>b. Short in AC secondary circuit; rectifiers CR301 through CR306, filter capacitors C1 or C2, etc.</li> <li>c. Shorted transistors Q802 through Q805, Q507, Q508, Q510 or Q511.</li> </ul>                                       |
| <p><b>CAUTION:</b> Because the driver and output stages are direct coupled, components may fail as a direct result of an initial component failure. If a shorted semiconductor is found, be sure to check the remaining driver and output components for short or open circuits before re-energizing the amplifier. After replacement of any of these components, increase the Variac voltage slowly while monitoring the wattmeter as described in paragraph C of Performance Verification.</p> |                                                                                                                                                                                                                                                                                                                                             |
| 3. High DC voltage at loudspeaker terminals before time delay circuit is deactivated.                                                                                                                                                                                                                                                                                                                                                                                                            | <ul style="list-style-type: none"> <li>a. Defective (open, shorted or leaky) transistors Q301, Q302 or Q303.</li> </ul>                                                                                                                                                                                                                     |
| 4. High DC voltage at amplifier board output terminals.                                                                                                                                                                                                                                                                                                                                                                                                                                          | <ul style="list-style-type: none"> <li>a. Open transistors Q507, Q508, Q510 or Q511.</li> <li>b. Defective (leaky or shorted) transistors Q516 or Q517.</li> </ul>                                                                                                                                                                          |
| 5. No DC Balance.                                                                                                                                                                                                                                                                                                                                                                                                                                                                                | <ul style="list-style-type: none"> <li>a. Defective (open, shorted or leaky) transistors Q501 or Q502, or Zener diodes CR501 or CR502.</li> <li>b. Leaky capacitor C502.</li> <li>c. Open resistors R501, R502 or R503.</li> </ul>                                                                                                          |
| 7. Parasitic Oscillation.                                                                                                                                                                                                                                                                                                                                                                                                                                                                        | <ul style="list-style-type: none"> <li>a. Open capacitors C505, C506, C516, C518, C519, C520 or C801.</li> <li>b. Defective (open, shorted or leaky) capacitors C508, C509 or C510.</li> </ul>                                                                                                                                              |
| 8. Improper Clipping                                                                                                                                                                                                                                                                                                                                                                                                                                                                             | <ul style="list-style-type: none"> <li>a. Improper adjustment of R541 or R542.</li> <li>b. Open transistors Q802 through Q805.</li> </ul>                                                                                                                                                                                                   |
| 9. Relay Latching                                                                                                                                                                                                                                                                                                                                                                                                                                                                                | <ul style="list-style-type: none"> <li>a. Improper adjustment of R541 or R542.</li> <li>b. High level DC offset at junction of R302 and R305.</li> </ul>                                                                                                                                                                                    |
| 10. No Output                                                                                                                                                                                                                                                                                                                                                                                                                                                                                    | <ul style="list-style-type: none"> <li>a. Open resistors R529 or R530.</li> <li>b. Open transistors Q510, Q511, Q802, Q803, Q804 or Q805.</li> </ul>                                                                                                                                                                                        |

# PARTS LIST

Reference Designation	Description and/or Remarks	Marantz Part Number
A1, A2	<b>HEATSINK ASSEMBLY</b>	215-1011-100
	Transistor Socket	368-1000-000
	Transistor Insulator (TO-3)	371-1006-000
	<b>POWER AMPLIFIER BOARD ASSEMBLY</b>	200-1053-100
C501	Cap., 150pf, $\pm 10\%$ , 100V	385-1038-000
C502	Cap., Elect., 10 $\mu$ f, 20V	381-1068-000
C503	Cap., Elect., 10 $\mu$ f, 25V	381-1034-000
C504	Cap., Elect., 10 $\mu$ f, 25V	381-1034-000
C505	Cap., 36pf, $\pm 5\%$ , 100V	385-1064-000
C506	Cap., 680pf, $\pm 5\%$ , 100V	385-1042-000
C507	Cap., Elect., 220 $\mu$ f, 6.3V	381-1044-000
C508	Cap., 47pf, $\pm 10\%$ , 100V	385-1040-000
C509	Cap., 36pf, $\pm 5\%$ , 300V	385-1018-000
C510	Cap., 0.1 $\mu$ f, $\pm 10\%$ , 250V	386-1000-000
C511	Cap., 0.1 $\mu$ f, $\pm 10\%$ , 250V	386-1000-000
C512	Cap., 1000pf, $\pm 10\%$ , 100V	385-1068-000
C513	Cap., 0.22 $\mu$ f, $\pm 10\%$ , 250V	386-1017-000
C514	Cap., 1600pf, $\pm 10\%$ , 300V	385-1020-000
C515	Cap., 1600pf, $\pm 10\%$ , 300V	385-1020-000
C516	Cap., 0.1 $\mu$ f, $\pm 10\%$ , 250V	386-1000-000
C517	Cap., 1.0 $\mu$ f, $\pm 20\%$ , 100V	388-1001-000
C518	Cap., 5pf, $\pm 10\%$ , 100V	385-1049-000
C519	Cap., 0.1 $\mu$ f, $\pm 10\%$ , 250V	386-1000-000
C520	Cap., 6800pf, $\pm 10\%$ , 400V	386-1026-000
C521	Cap., 0.1 $\mu$ f, $\pm 10\%$ , 250V	386-1000-000
CR501	Diode, Zener	459-1006-000
CR502	Diode, Zener	459-1006-000
CR503	Diode, Signal	460-1011-000
L501	Toroid	147-1007-000
R501	Res., C/F, 4.7K, $\pm 5\%$ , 1/2W	433-4772-000
R502	Res., Variable, 2K, 2W	420-1000-000
R503	Res., C/F, 4.7K, $\pm 5\%$ , 1/2W	433-4472-000

Reference Designation	Description and/or Remarks	Marantz Part Number
R504	Res., C/F, 100K, $\pm 5\%$ , 1/4W	434-6102-000
R505	Res., C/F, 470K, $\pm 5\%$ , 1/4W	434-6472-000
R506	Res., C/F, 1K, $\pm 5\%$ , 1/4W	434-4102-000
R507	Res., C/F, 100K, $\pm 5\%$ , 1/4W	434-6102-000
R508	Res., C/F, 91K, $\pm 5\%$ , 1/4W	434-5912-000
R509	Res., C/F, 3.3K, $\pm 5\%$ , 1/4W	434-4332-000
R510	Res., C/F, 8.2K, $\pm 5\%$ , 1/4W	434-4822-000
R511	Res., C/F, 680 ohm, $\pm 5\%$ , 1/4W	434-3682-000
R512	Res., C/F, 7.5K, $\pm 5\%$ , 1/2W	433-4752-000
R513	Res., Prec., 1K, $\pm 1\%$ , 1/4W	431-4100-000
R514	Res., C/F, 2K, $\pm 5\%$ , 1/4W	434-4202-000
R515	Res., C/F, 27 ohm, $\pm 5\%$ , 1/2W	433-2272-000
R516	Res., C/F, 220 ohm, $\pm 5\%$ , 1/4W	434-3222-000
R517	Res., W/W, 1.5K, $\pm 10\%$ , 2W	436-4153-000
R518	Res., W/W, 1.5K $\pm 10\%$ , 2W	436-4153-000
R519	Res., Prec., 20K, $\pm 1\%$ , 1/4W	431-5200-000
R520	Res., C/F, 100K, $\pm 5\%$ , 1/4W	434-6102-000
R521	Res., C/F, 300 ohm, $\pm 5\%$ , 1/4W	434-3302-000
R522	Res., C/F, 560 ohm, $\pm 5\%$ , 1/2W	433-3562-000
R523	Res., C/F, 560 ohm, $\pm 5\%$ , 1/2W	433-3562-000
R524	Res., C/F, 27K, $\pm 5\%$ , 1/4W	434-5272-000
R525	Res., C/F, 27K, $\pm 5\%$ , 1/4W	434-5272-000
R526	Res., Variable, 250 ohm, 2W	420-1025-000
R527	Res., C/F, 47 ohm, $\pm 5\%$ , 1/2W	433-2472-000

Reference Designation	Description and/or Remarks	Marantz Part Number
R528	Res., C/F, 47 ohm, $\pm 5\%$ , 1/2W	433-2472-000
R529	Res., C/C, 39 ohm, $\pm 10\%$ , 1W	423-2393-000
R530	Res., C/C, 39 ohm, $\pm 10\%$ , 1W	423-2393-000
R531	Res., W/W, 0.1 ohm, $\pm 5\%$ , 5W	145-1002-000
R532	Res., W/W, 0.1 ohm, $\pm 5\%$ , 5W	145-1002-000
R533	Res., W/W, 0.15 ohm, $\pm 10\%$ , 5W	428-0153-000
R534	Res., W/W, 0.15 ohm, $\pm 10\%$ , 5W	428-0153-000
R535	Res., W/W, 0.15 ohm, $\pm 10\%$ , 5W	428-0153-000
R536	Res., W/W, 0.15 ohm, $\pm 10\%$ , 5W	428-0153-000
R537	Res., C/F, 330 ohm, $\pm 5\%$ , 1/4W	434-3332-000
R538	Res., C/F, 330 ohm, $\pm 5\%$ , 1/4W	434-3332-000
R539	Res., C/C, 27 ohm, $\pm 5\%$ , 2W	424-2272-000
R540	Res., C/F, 2.2K, $\pm 5\%$ , 1/2W	433-4222-000
R541	Res., Variable, 2.5K, 1/4W	420-1029-000
R542	Res., Variable, 2.5K, 1/4W	420-1029-000
R543	Res., C/F, 2.2K, $\pm 5\%$ , 1/2W	433-4222-000
R544	Res., C/F, 1K, $\pm 5\%$ , 1/2W	433-4102-000
R545	Res., C/F, 1K, $\pm 5\%$ , 1/2W	433-4102-000
R546	Res., W/W, 1.0 ohm, $\pm 5\%$ , 2W	436-1102-000
R547	Res., C/F, 2.2K, $\pm 5\%$ , 1/4W	434-4222-000
R548	Res., C/F, 2.7K, $\pm 5\%$ , 1/4W	434-4272-000
R549	Res., C/F, 10K, $\pm 5\%$ , 1/4W	434-5102-000
R550	Res., C/F, 1K, $\pm 5\%$ , 1/4W	434-4102-000
R551	Res., C/F, 270K, $\pm 5\%$ , 1/4W	434-6272-000

Reference Designation	Description and/or Remarks	Marantz Part Number
R552	Res., C/C, 5.6 ohm, $\pm 5\%$ , 1W	423-1562-000
R553	Res., C/C, 5.6 ohm, $\pm 5\%$ , 1W	423-1562-000
R554	Res., C/F, 10K, $\pm 5\%$ , 1/4W	434-5102-000
R555	Res., C/F, 470 ohm, $\pm 5\%$ , 1/4W	434-3472-000
R556	Res., C/F, 75 ohm, $\pm 5\%$ , 1/4W	434-2752-000
R557	Res., C/F, 10 ohm, $\pm 5\%$ , 1/2W	433-2102-000
Q501	Transistor, NPN	462-1038-200
Q502	Transistor, NPN	462-1038-200
Q503	Transistor, PNP	461-1037-000
Q504	Transistor, NPN	462-1044-000
Q505	Transistor, PNP	461-1036-000
Q506	Transistor, NPN	462-1042-000
Q507	Transistor, PNP	461-1047-*
Q508	Transistor, NPN	462-1053-*
Q509	Not Used	
Q510	Transistor, NPN	462-1054-*
Q511	Transistor, PNP	461-1046-*
Q512	Not Used	
Q513	Not Used	
Q514	Not Used	
Q515	Not Used	
Q516	Transistor, NPN	462-1035-*
Q517	Transistor, PNP	461-1030-*
Q518	Transistor, PNP	461-1013-000
Q519	Transistor, PNP	461-1013-000
Q520	Transistor, NPN	462-1009-000
	Thermal Retainer (TO-92 Pair)	562-1005-000
	Heat Dissipater (TO-5)	562-1000-000
	Transistor Insulator (TO-5)	372-1000-000
	Toroid Retainer	570-1003-000
	Transistor Insulator (TO-66)	371-1007-000
	Nylon Washer	676-1006-000
C801	Cap., 0.1 $\mu$ f, $\pm 10\%$ , 250V	386-1000-000

Reference Designation	Description and/or Remarks	Marantz Part Number
Q801	Transistor, NPN (Contained in Heat Sensor Assy, 215-1006-100)	462-1043-000
Q802	Transistor, PNP	461-1031-*
Q803	Transistor, NPN	462-1036-*
Q804	Transistor, PNP	461-1031-*
Q805	Transistor, NPN	462-1036-*
	Heatsink	141-1009-000
A3	<b>RECTIFIER/RELAY BOARD ASSEMBLY</b>	200-1027-100
C301	Cap., Elect., 22 $\mu$ f, 25V	381-1046-000
C302	Cap., Elect., 220 $\mu$ f, 6.3V	381-1044-000
C303	Cap., Elect., 22 $\mu$ f, 63V	381-1040-000
CR301	Diode, Rectifier	460-1014-000
CR302	Diode, Rectifier	460-1014-000
CR303	Diode, Rectifier	460-1014-000
CR304	Diode, Rectifier	460-1014-000
CR305	Diode, Rectifier	460-1013-000
CR306	Diode, Rectifier	460-1013-000
K301	Relay, DPDT	410-1000-000
R301	Res., C/F, 12K, $\pm 5\%$ , 1/2W	433-5122-000
R302	Res., C/F, 10K, $\pm 5\%$ , 1/2W	433-5102-000
R303	Res., C/F, 75K, $\pm 5\%$ , 1/2W	433-5752-000
R304	Res., C/F, 75K, $\pm 5\%$ , 1/2W	433-5752-000
R305	Res., C/F, 7.5K, $\pm 5\%$ , 1/2W	433-4752-000

\*For applicable dash number, see Transistor Specification Chart on unit Schematic (Figure 11).

Reference Designation	Description and/or Remarks	Marantz Part Number
R306	Res., C/F, 27K, $\pm 5\%$ , 1/2W	433-5272-000
R307	Res., W/W, 2.2K, $\pm 5\%$ , 2W	436-4222-000
R308	Res., W/W, 2.2K, $\pm 5\%$ , 2W	436-4222-000
R309	Res., C/F, 470K, $\pm 5\%$ , 1/2W	433-6472-000
R310	Res., W/W, 560 ohm, $\pm 5\%$ , 5W	428-3562-000
Q301	Transistor, NPN	462-1000-000
Q302	Transistor, NPN	462-1007-000
Q303	Transistor, NPN	462-1000-000
	Transistor Insulator (TO-5)	372-1000-000
	<b>MISCELLANEOUS PARTS</b>	
J1	A.C. Outlet	360-1001-000
J2 & J3	Input Jack	360-1009-000
TB2	Speaker Terminal Block	363-1003-000
XF1	Fuse Holder (w/Mtg. Hardware)	367-1001-000
C1	Cap., Elect., 20,000 $\mu$ f, 60V	381-1041-000
C2	Cap., Elect., 20,000 $\mu$ f, 60V	381-1041-000
T1	Transformer, Power	440-1010-100
F1	Fuse, 6 amp, 250V	451-1013-000
	Plastic Foot	567-1000-000
	Front Panel Assembly	206-1011-100
	Shroud Lamp	483-1000-000
DS1	Lamp	482-1006-000

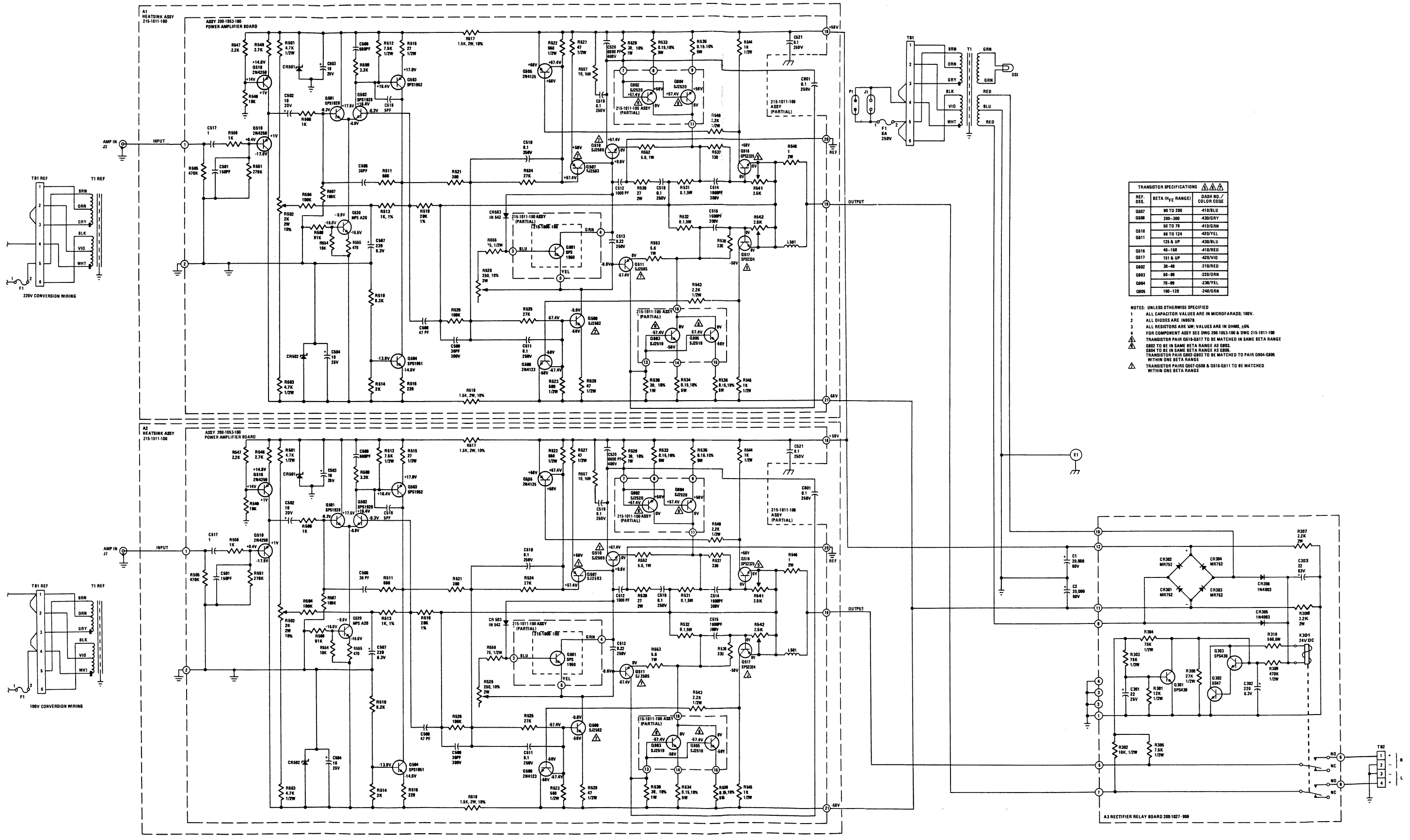

RES. DES.	BETA (F <sub>E</sub> RANGE)	DATA NO. / COLOR CODE
Q507	90 TO 200	-410/BLU
Q508	200-300	-430/GRY
Q510	50 TO 70	-410/GRN
Q511	80 TO 124	-420/YEL
Q516	125 & UP	-430/BLU
Q517	40-150	-410/RED
Q518	151 & UP	-420/VIO
Q802	30-40	-210/RED
Q803	50-60	-220/GRN
Q804	70-80	-230/YEL
Q805	100-120	-240/GRN

NOTES: UNLESS OTHERWISE SPECIFIED  
 1 ALL CAPACITOR VALUES ARE IN MICROFARADS: 100V.  
 2 ALL DIODES ARE 1N907A  
 3 ALL RESISTORS ARE 1/2W UNLESS OTHERWISE SPECIFIED  
 4 FOR COMPONENT ASSY SEE DWG 200-1053-100 & DWG 215-1011-100  
 TRANSISTOR PAIR Q516-Q517 TO BE MATCHED IN SAME BETA RANGE  
 Q802 TO BE IN SAME BETA RANGE AS Q803  
 Q804 TO BE IN SAME BETA RANGE AS Q805  
 TRANSISTOR PAIR Q802-Q803 TO BE MATCHED TO PAIR Q804-Q805 WITHIN ONE BETA RANGE  
 TRANSISTOR PAIRS Q507-Q508 & Q510-Q511 TO BE MATCHED WITHIN ONE BETA RANGE

FIGURE 11. MODEL 240 SCHEMATIC

# 220 and 100 VOLT AC CONVERSION

## 220-VOLT AC CONVERSION

To convert the Model 240 to 220-volt operation, perform the following steps:

1. Remove the top cover.
2. Orient the Model 240 so that the rear panel is facing toward the viewer.
3. Locate TB1, the strip located on the power transformer half shell facing the rear panel, which terminates the power transformer primary wires.
4. Unsolder all jumpers from TB1.
5. Solder a jumper (18 AWG) to TB1 connecting the grey and violet transformer wires.
6. Re-attach the top cover.
7. Replace the 6-amp, 250V fuse in the unit with the 4-amp, 250V fuse, Part #451-1003, supplied with the 220-volt conversion kit, Part #105-1007-1.
8. Affix labels, supplied in conversion kit, in the appropriate locations on the unit cover, and adjacent to the line cord, fuse holder and the accessory outlet.

The model 240 is now ready for 220-volt operation.

## 100-VOLT AC CONVERSION

To convert the Model 240 to 100-volt operation, perform the following steps:

1. Remove the top cover.
2. Orient the Model 240 so that the rear panel is facing toward the viewer.
3. Locate TB1, the terminal strip located on the power transformer half shell facing the rear panel, which terminates the power transformer primary wires.
4. Unsolder the black and white power lead-in wires and all jumpers from TB1.
5. Solder two jumpers (18 AWG) to TB1, one connecting the orange and violet transformer wires, and one connecting the grey and white transformer wires. Solder the black and white power lead-in wires to the white and orange transformer wires, respectively, at TB1.
6. Re-attach the top cover.
7. Affix the labels, supplied in the 100-volt conversion kit, Part #105-1008-1, in the appropriate locations on the unit cover, and adjacent to the line cord and the accessory outlet.

The Model 240 is now ready for 100-volt operation.