



SERVICE MANUAL **2250B**



marantz

model **2250B**

Stereophonic Receiver

3. AM ALIGNMENT PROCEDURE

3.1 AM IF Alignment

1. Connect a sweep generator to the J153 and an alignment scope to the test point B.
2. Rotate each core of IF transformer L153 for maximum height and flat top symmetrical response.

3.2 AM Frequency Range and Tracking Alignment

1. Set AM signal generator to 515 kHz. Turn the tuning capacitor fully closed (place the tuning pointer at the low end) and adjust the oscillator coil L152 for maximum audio output.
2. Set the signal generator to 1650 kHz. Place the tuning pointer in the high frequency end and adjust the oscillator trimmer on the oscillator tuning capacitor for maximum audio output.
3. Repeat steps 1 and 2 until no further adjustment is necessary.
4. Set the generator to 600 kHz and tune the receiver to the same frequency and adjust a slug core of AM ferrite rod antenna and RF coil L151 for maximum output.
5. Set the generator to 1400 kHz and tune the receiver to the same frequency and adjust both trimming capacitors of antenna and RF tuned circuit for maximum output.
6. Repeat steps 4 and 5 until no further adjustment is necessary.

Note: During tracking alignment reduce the signal generator output as necessary to avoid AGC action.

3.3 AM Signal Strength Meter Alignment

Set an AM signal generator to 1000 kHz at $5\mu\text{V}$, and adjust R178 so that the signal strength meter may read 90% of the full scale.

4. FM ALIGNMENT PROCEDURE

1. Connect an FM signal generator to the FM ANTENNA terminals and an oscilloscope and an audio distortion analyzer to the TAPE OUTPUT jacks on the rear panel.
2. Set the FM SG to 87 MHz and provide about 3 to $5\mu\text{V}$. Place the tuning pointer at the low frequency end by rotating the tuning knob and adjust the core of oscillator coil L104 to obtain maximum audio output.
3. Set the FM SG to 109 MHz and provide about 3 to $5\mu\text{V}$ output. Rotate the tuning knob and place the tuning pointer at the high frequency end and adjust the trimming capacitor C106 for maximum output.
4. Repeat steps 2 and 3 until no further adjustment is necessary.
5. Set the FM SG to 90 MHz and tune the receiver to the same frequency. Decrease signal generator output until the audio output level decreases with the decreasing generator output. Adjust the antenna coil L101, RF coils L102 and L103 and IF transformer L105 for minimum audio distortion.
6. Set the FM SG to 106 MHz and tune the receiver to the same frequency. Adjust the trimming capacitor C102, C104 and C105 for minimum distortion.
7. Repeat steps 5 and 6 until no further adjustment is necessary.
8. Adjust the secondary core (upper) of discriminator transformer L201 so that the center tuning meter pointer indicates its center at no signal applied. Set the FM SG to 98 MHz and increase its output level $1\mu\text{V}$ and tune the receiver to the same frequency so that the center tuning meter pointer indicates its center.
Adjust the primary core (lower) of L201 for minimum distortion.
9. Set the FM SG to 98 MHz at $1000\mu\text{V}$, and adjust R374 so that the signal strength meter may read 90% of the full scale.

5. STEREO SEPARATION ALIGNMENT

1. Set the FM SG to provide $1\text{ }\mu\text{V}$ at 98 MHz. Tune the receiver to the same frequency so that the center tuning meter pointer indicates its center.
2. Turn the FM SG modulation off (with the pilot signal turned off), connect a frequency counter to test point J310, and adjust R311 so that the frequency counter may precisely read 19 kHz.
3. Modulate the FM SG with stereo composite signal consisting only of subchannel signal (of course a pilot signal must be included).
4. Adjust the trimming resistor R301 for maximum and same separation in both channels.

6. MUTING CIRCUIT ALIGNMENT

1. Connect a VTVM across the resistor R363 and adjust the resistor R363 until the meter reads 0.75V DC at no signal.
2. Set the FM SG to provide $1\text{ }\mu\text{V}$ at 98 MHz and tune the receiver to the same frequency correctly.
3. Turn on MUTING push switch. Shift the FM signal generator frequency to plus and minus and note both plus and minus shifted frequencies at which undesirable audio side responses are muted out. Adjust the R363 so that the same shifted frequencies mute the undesirable side response.
4. Adjust R362 for proper frequency shift at which the muting circuit operates.

7. DOLBY FM TAPE OUTPUT SETTING

1. Set the modulation of FM SG to 400 Hz, 50% ($\pm 37.5\text{ kHz Dev.}$)
2. Set the FM SG to provide $1\text{ }\mu\text{V}$ at 98 MHz. Tune the receiver to the same frequency so that the center tuning meter pointer indicates its center.
3. Turn on DOLBY FM push switch. Set the semifixed resistors RC01 and RC02 so that the output of the TAPE OUTPUT terminals R and L become 580 mV at VTVM.

8. AUDIO ADJUSTMENT

1. Voltage adjustment
Connect a DC voltmeter between pin terminal 804 and 805, and adjust the trimming resistor R806 for 35V DC.
2. Main Amplifier DC off-set alignment
Connect a DC voltmeter with 0.5 or 1 V range between the speaker terminals and adjust the trimming resistor R707 for "zero" DC output on the meter.
Repeat the same procedure for the other channel.
Note: During this alignment no load should be connected to the speaker terminals.
3. Idle-current adjustment
Connect a VTVM between pin terminals 708 and 710. Next, adjust the trimming resistor R719 so the VTVM reads 10mV DC. Repeat the same procedure for the other channel.
4. Check DC off-set voltage aligned in the procedure 2 and if any DC output is observed on the DC voltmeter, adjust the R707 again for "zero" output.
5. Phono-amplifier adjustment
Connect an oscilloscope to the TAPE OUT jacks and an audio signal generator to the PHONO jacks. Place the selector switch in the PHONO position. Increase 1 kHz audio signal gradually until a slight clipping on top of the sine-wave is observed on the oscilloscope. Adjust the trimming resistor R408 for equal clipping level.
For the other channel adjust R409.

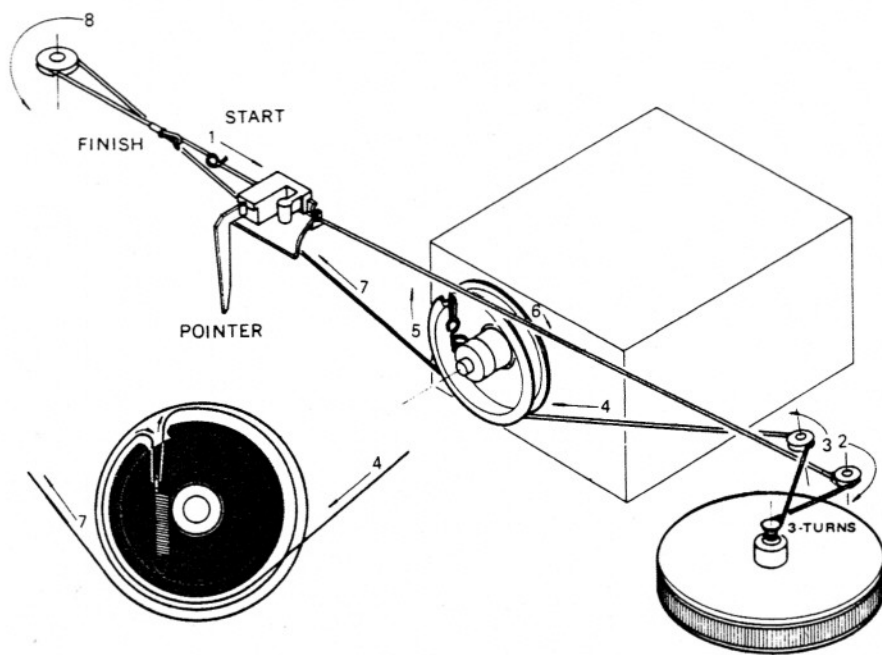
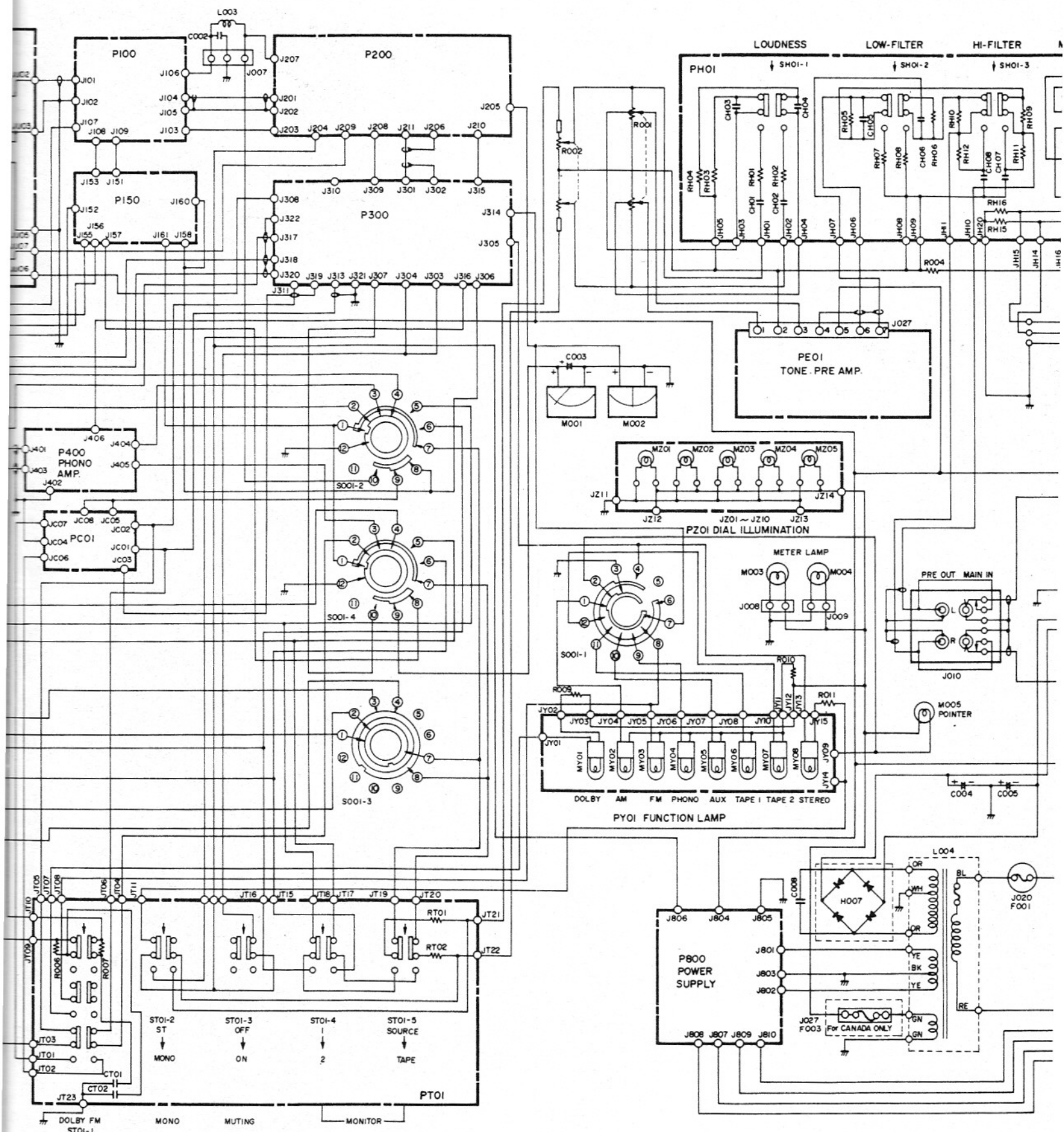

Figure 1. Dial Stringing



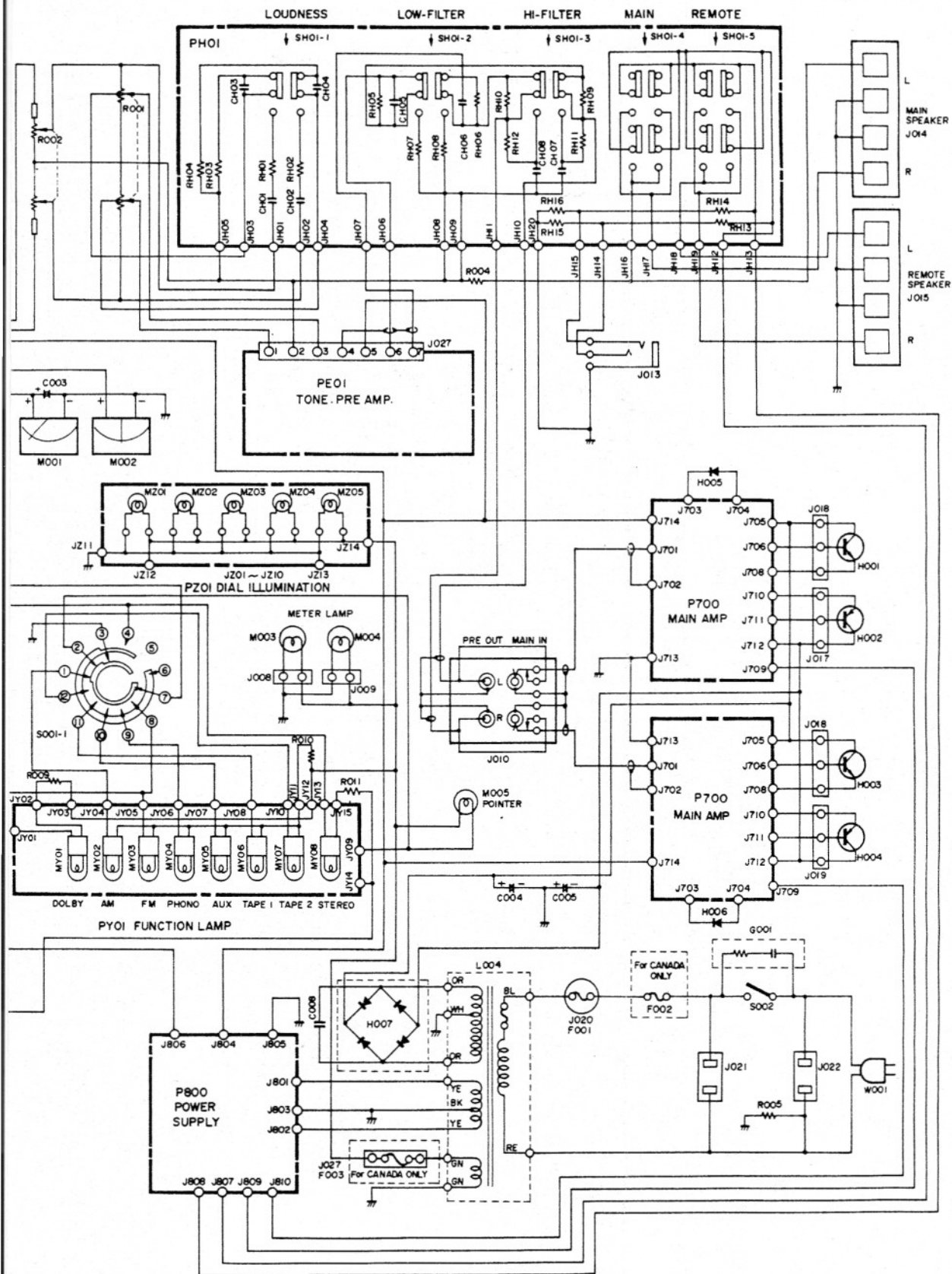
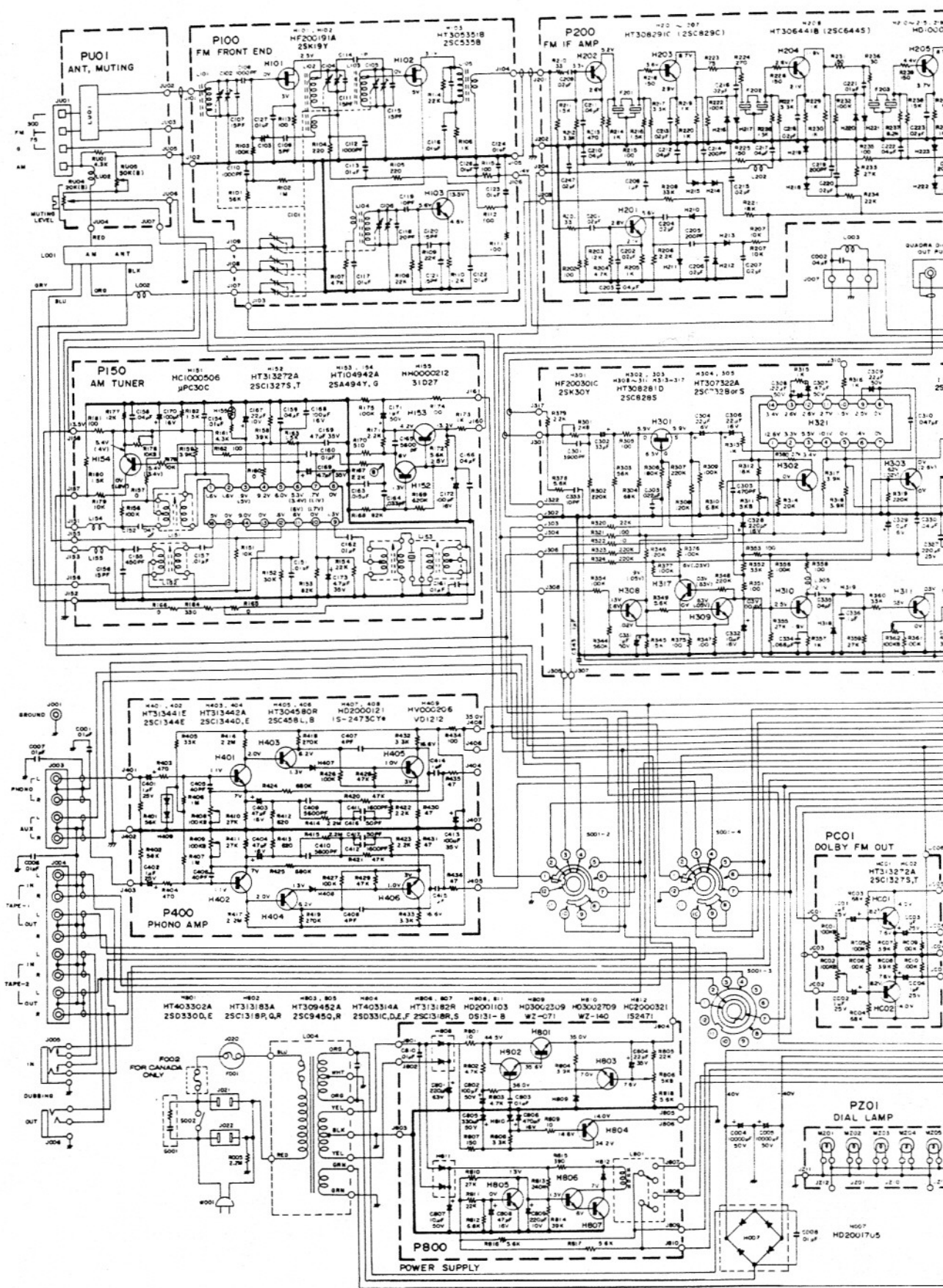

Figure 2. Wiring Diagram



Model 2250B NOTE: This schematic diagram applied to units manufactured for the U.S.A. market.

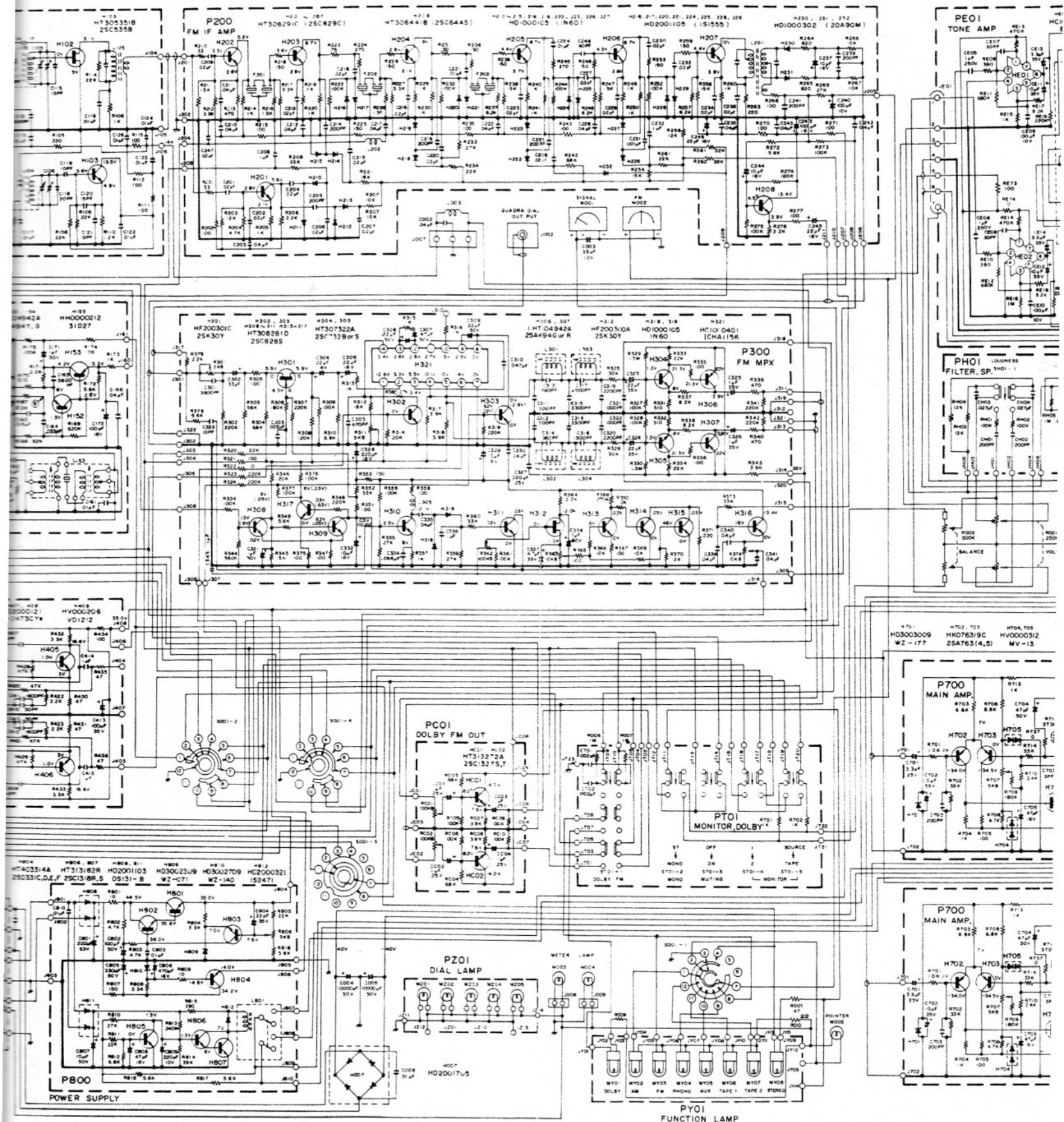

Diagram applied to units manufactured for the U.S.A. market.

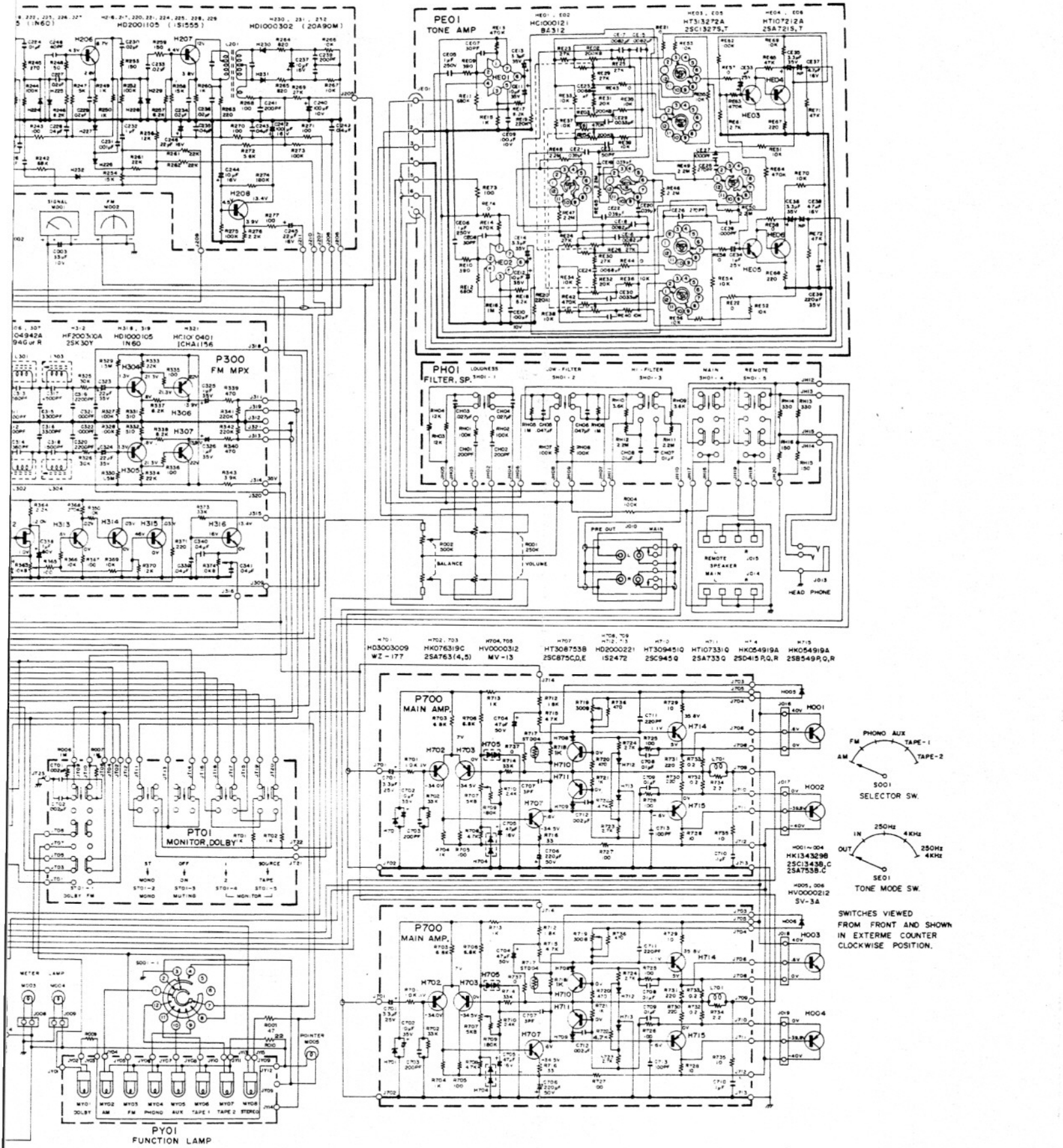

Figure 3. Schematic Diagram

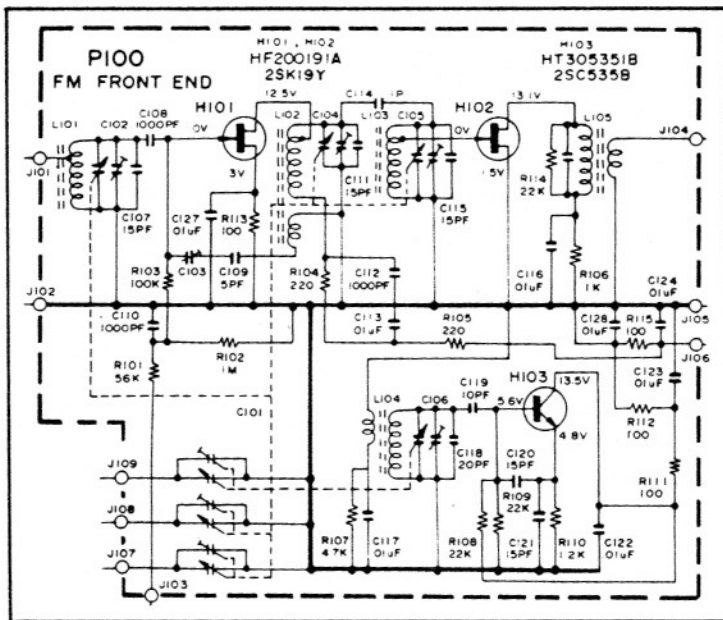

Figure 9. FM Front End (P100) Schematic Diagram

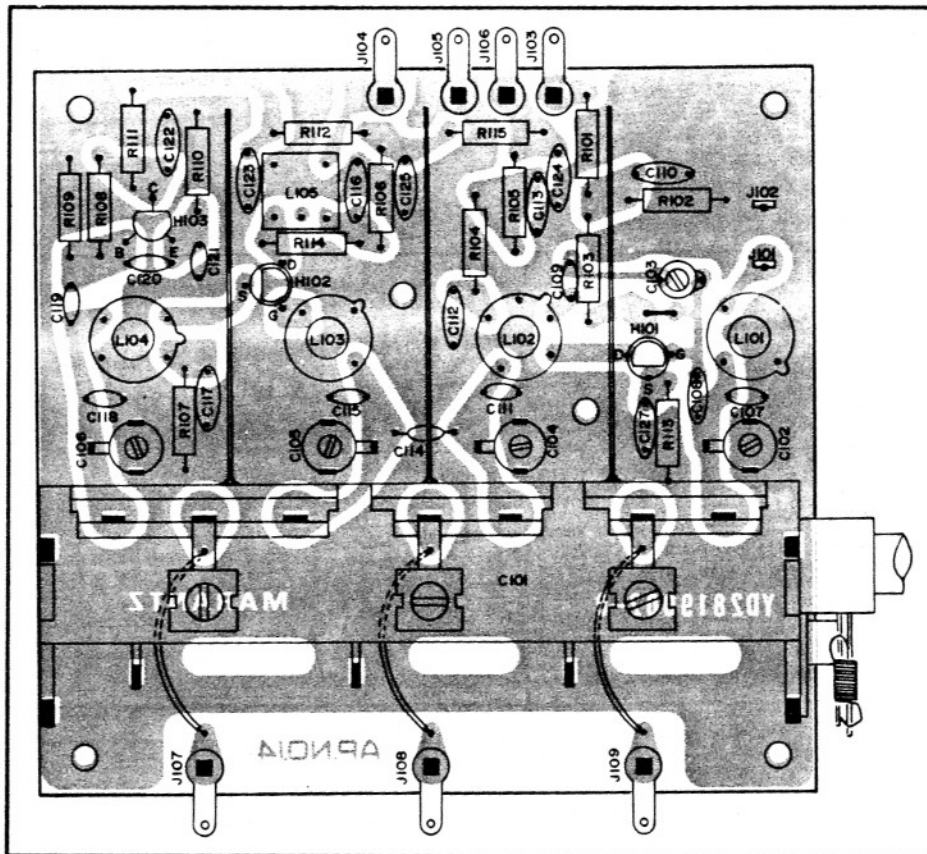

Figure 10. FM Front End (P100) Component Locations

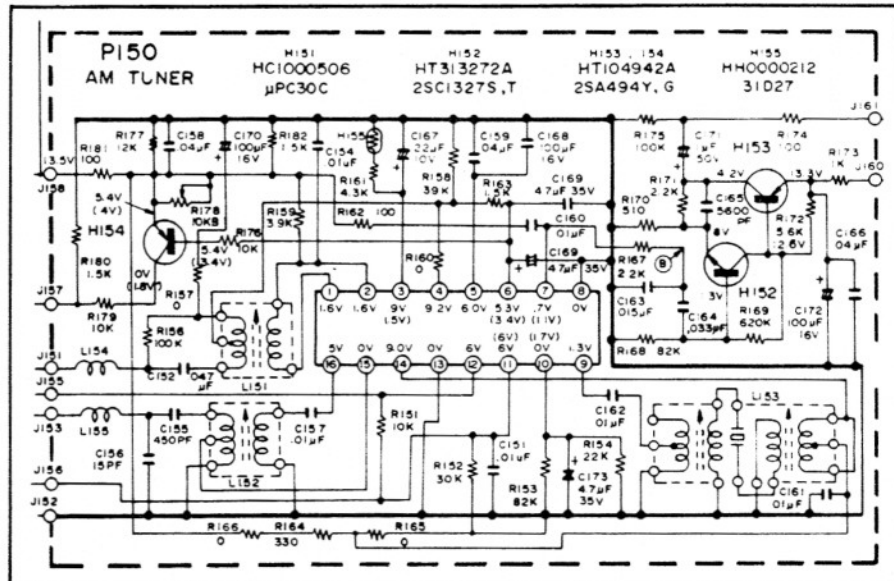

Figure 11. AM Tuner (P150) Schematic Diagram

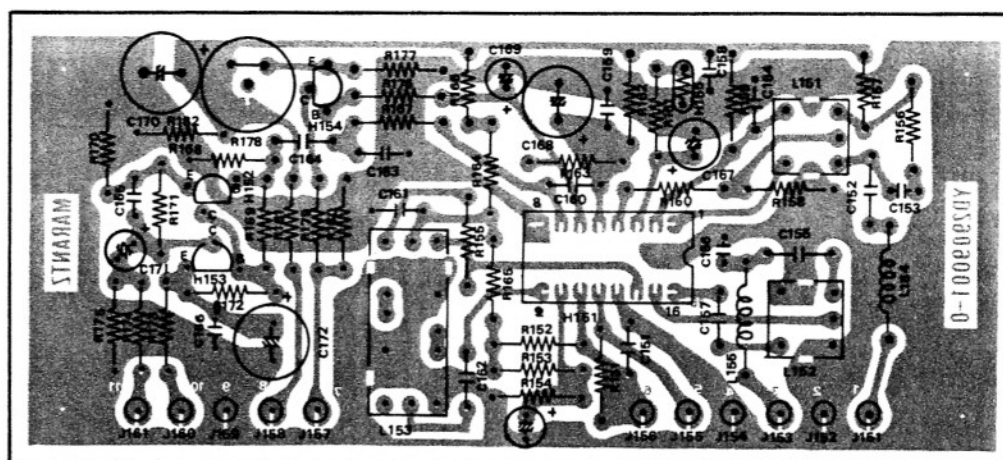

Figure 12. AM Tuner (P150) Component Locations

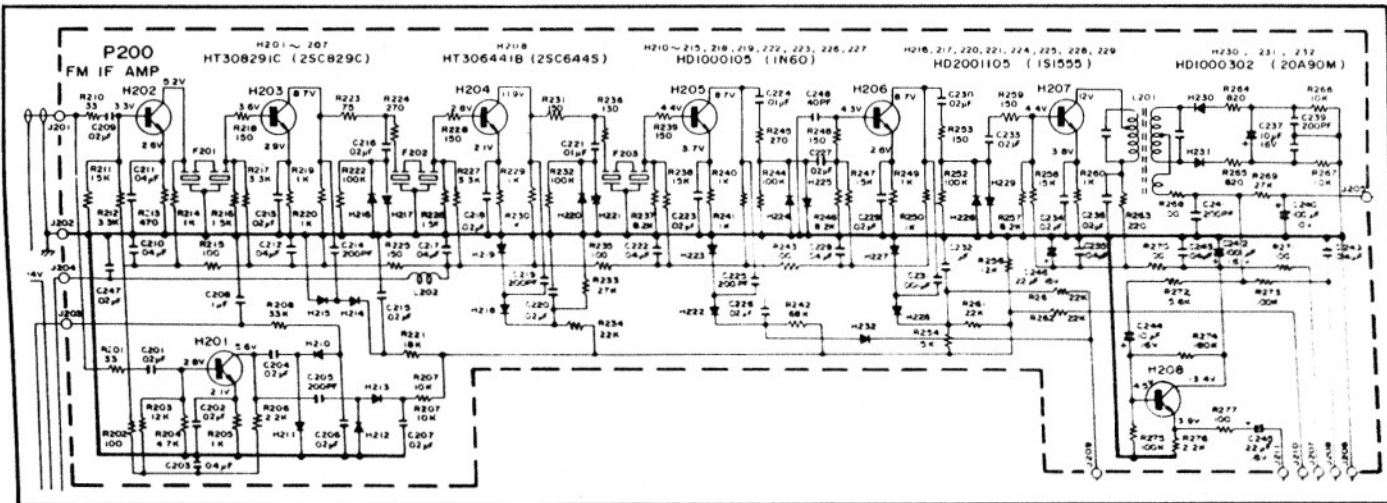

Figure 13. FM IF (P200) Schematic Diagram

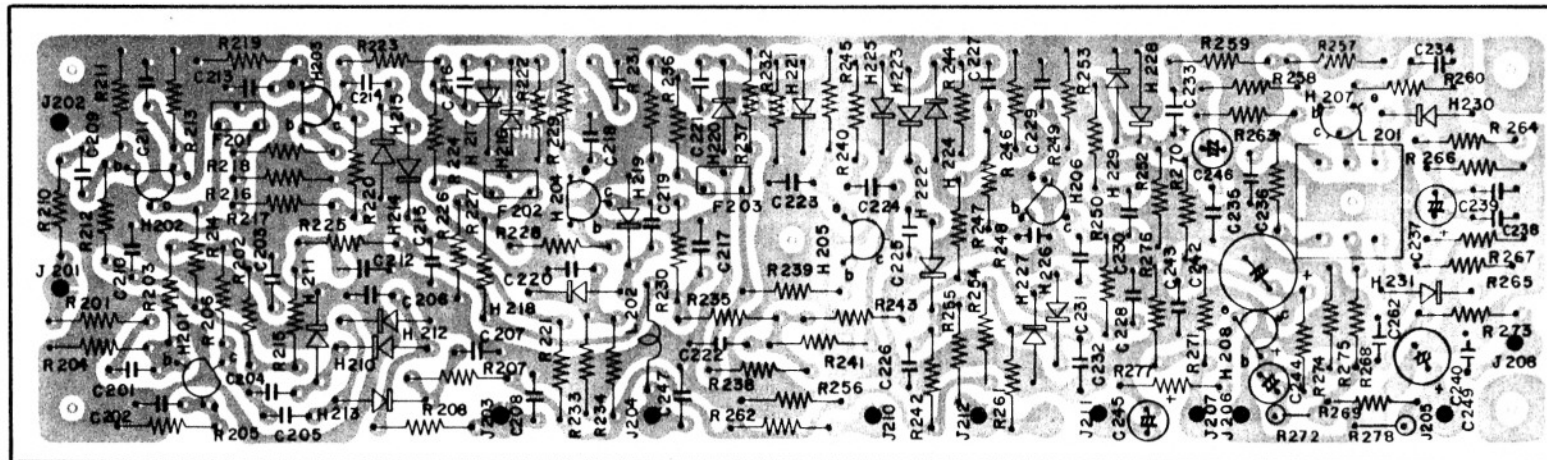

Figure 14. FM IF (P200) Component Locations

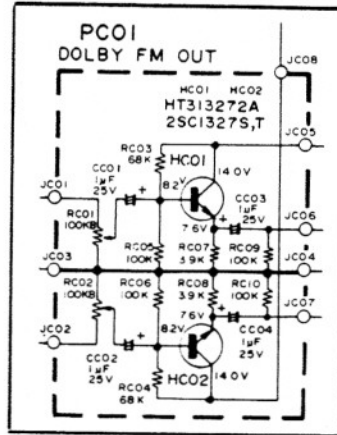

Figure 17. Dolby FM Assembly (PC01) Schematic Diagram

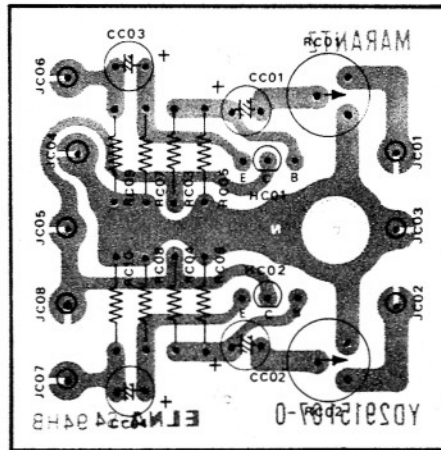

Figure 18. Dolby FM Assembly (PC01) Component Locations

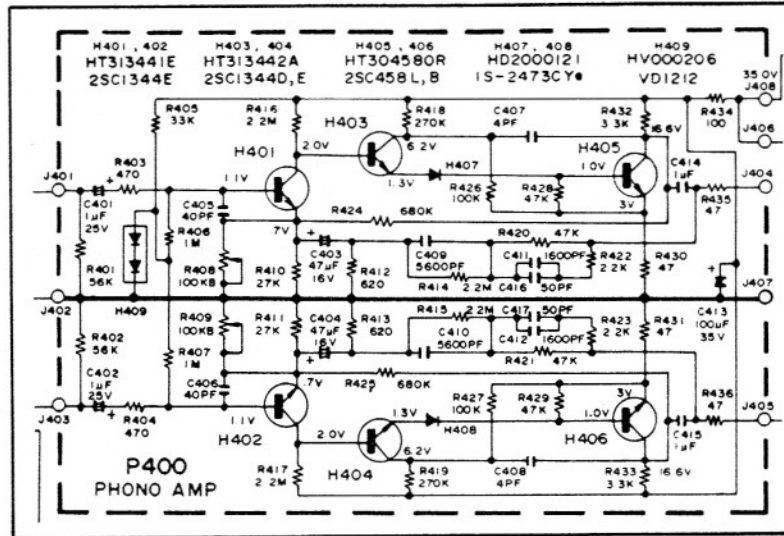

Figure 19. Phono Amplifier (P400) Schematic Diagram

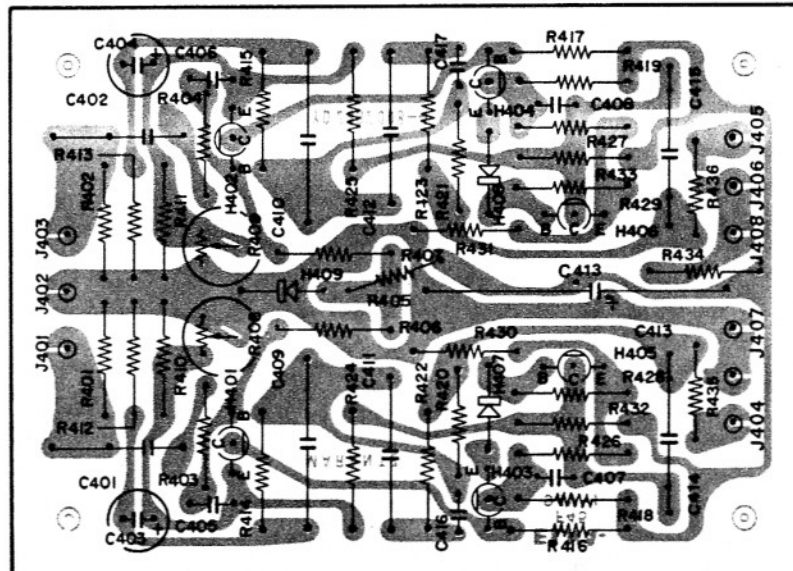

Figure 20. Phono Amplifier (P400) Component Locations

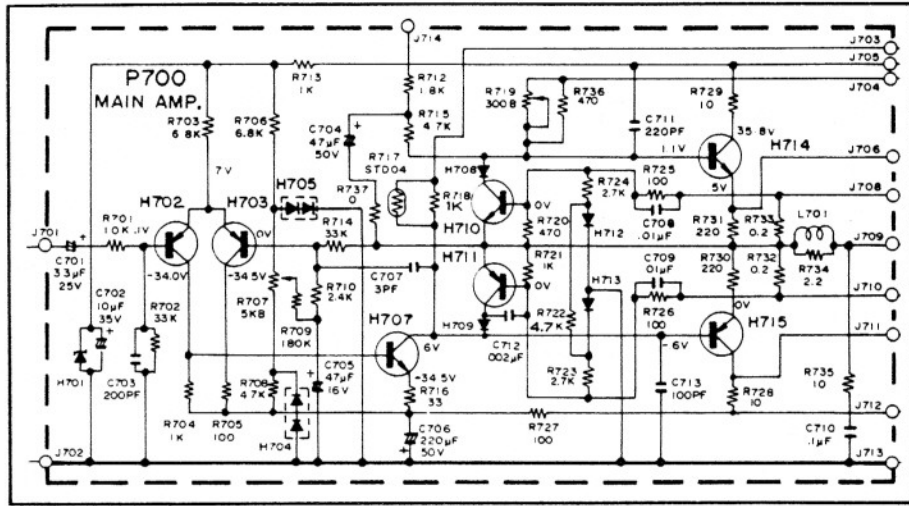

Figure 21. Main Amplifier (P700) Schematic Diagram

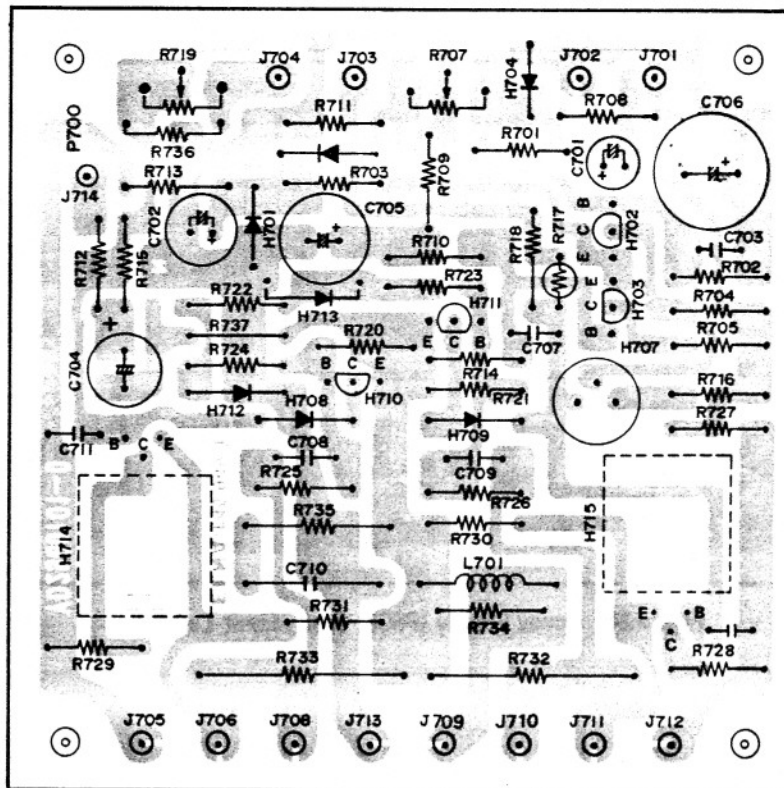

Figure 22. Main Amplifier (P700) Component Locations

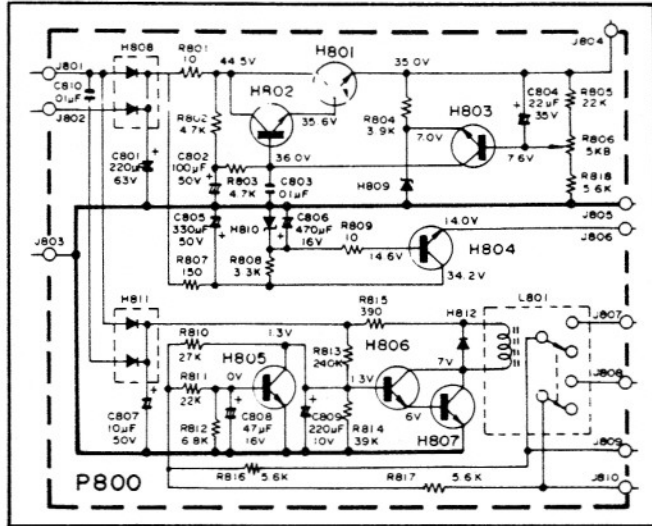

Figure 23. Power Supply (P800) Schematic Diagram

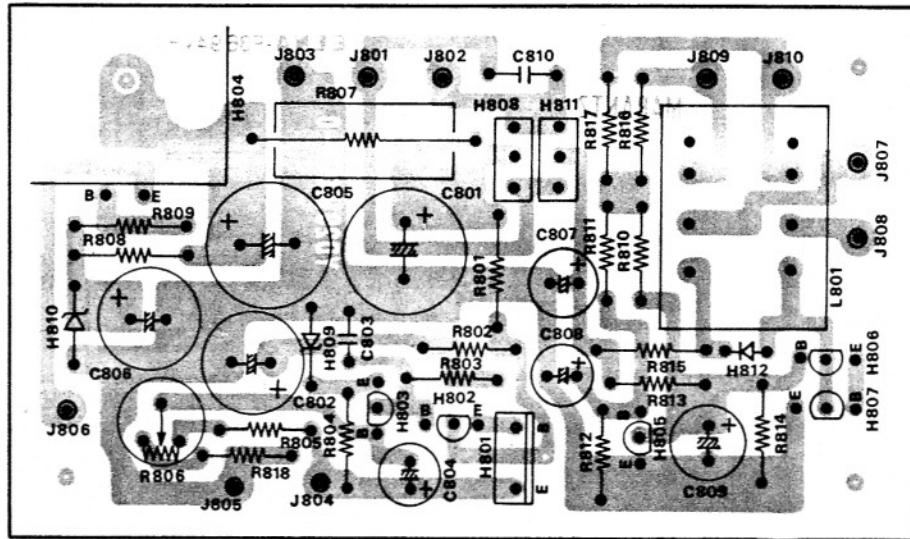

Figure 24. Power Supply (P800) Component Locations

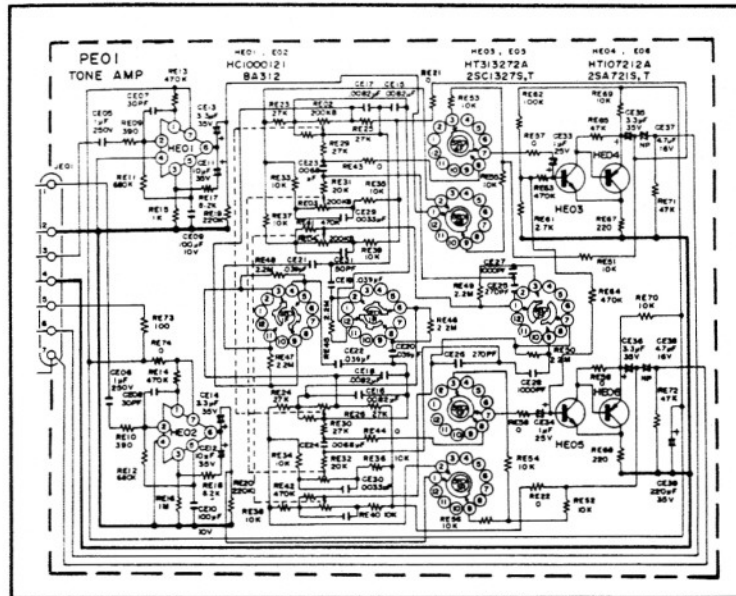

Figure 25. Pre Tone Amplifier (PE01) Schematic Diagram

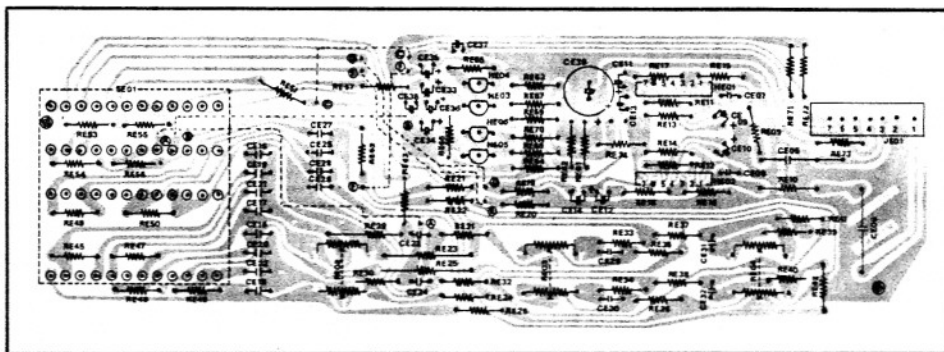

Figure 26. Pre Tone Amplifier (PE01) Component Locations

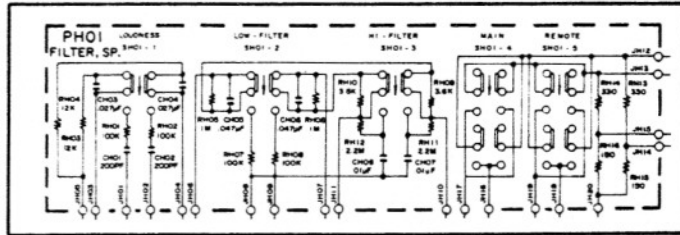

Figure 27. Filter (PH01) Schematic Diagram

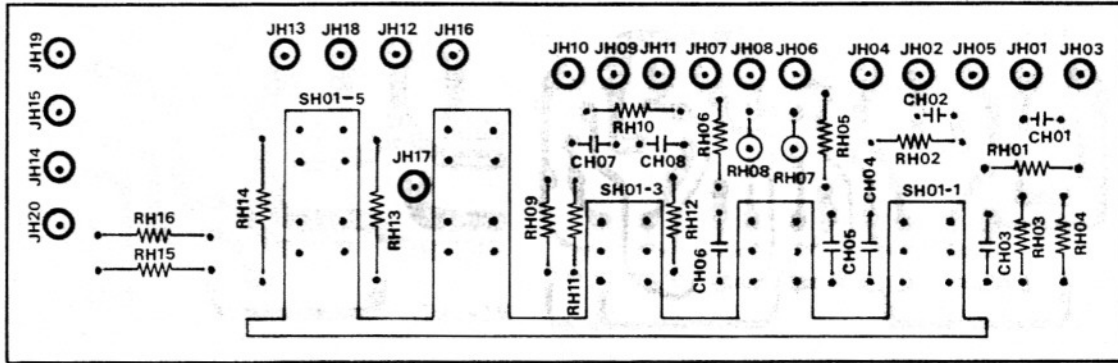

Figure 28. Filter (PH01) Component Locations

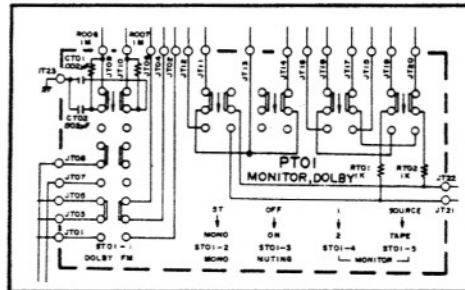

Figure 29. Monitor (PT01) Schematic Diagram

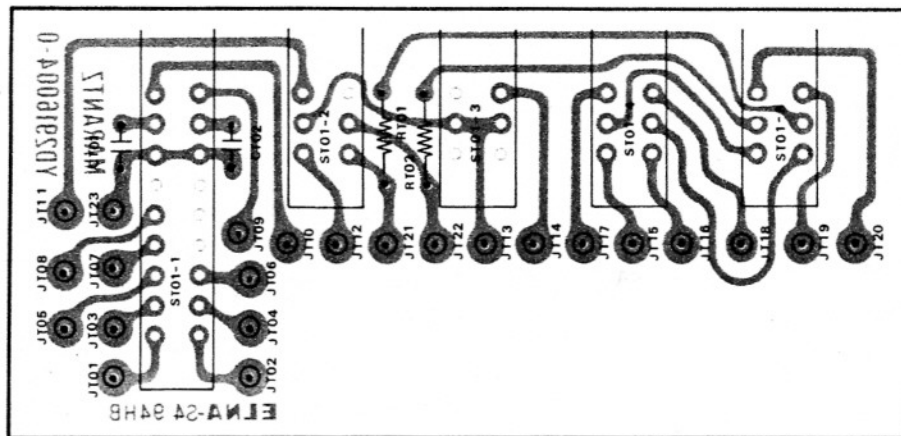

Figure 30. Monitor (PT01) Component Locations

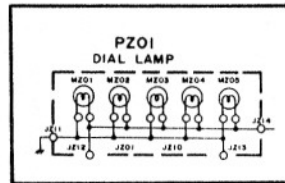

Figure 31. Dial Lamp (PZ01) Schematic Diagram

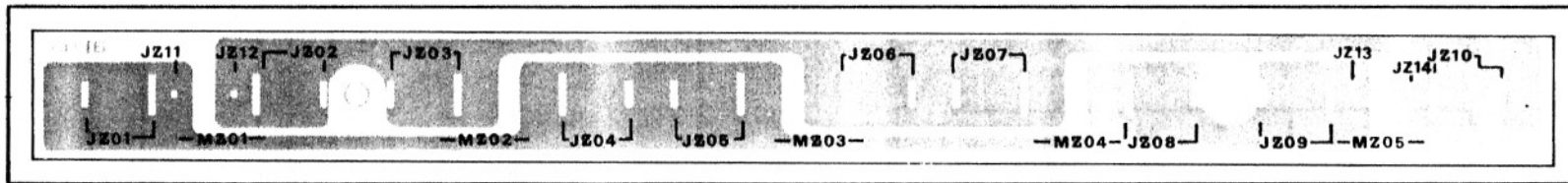

Figure 32. Dial Lamp (PZ01) Component Locations

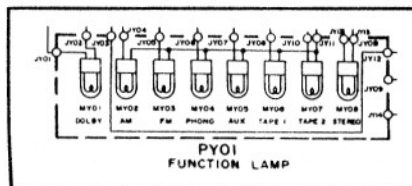

Figure 33. Function Lamps Assembly (PY01) Schematic Diagram

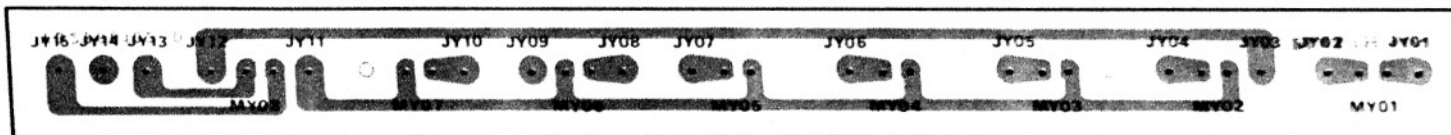

Figure 34. Function Lamps Assembly (PY01) Component Locations