

244

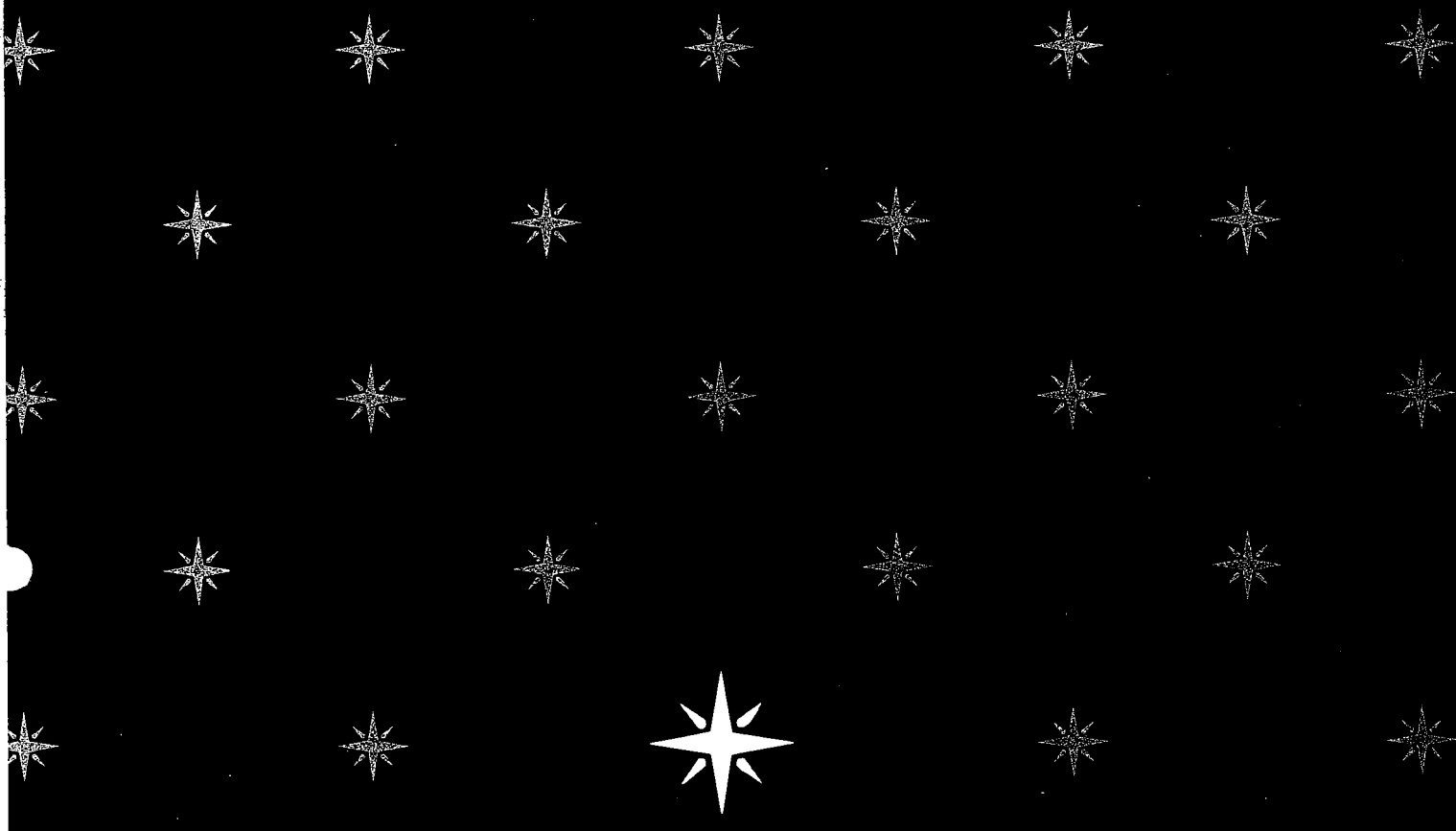

**SERVICE
MANUAL 2250**



marantz

model 2250

Stereophonic Receiver

TABLE OF CONTENTS

SECTION	PAGE
Introduction	1
P.W. Board	1
Test Equipment Required for Servicing	2
AM Alignment Procedure	2
FM Alignment Procedure	3
Stereo Separation Alignment	3
Muting Circuit Alignment	3
Dolby FM Tape Output Setting	4
Audio Adjustment	4
Technical Specifications (for U.S.A. Model)	25
Parts List	27
Service Information for European Model	38
Technical Specifications (for European Model)	38

LIST OF ILLUSTRATIONS

FIGURE	PAGE
1. Dial Stringing	4
2. Wiring Diagram	5
3. Schematic Diagram	6
4. Exploded Mechanical Diagram	8
5. Front Panel Adjustments and Component Locations	10
6. Main Chassis Component Locations (Top View)	10
7. Rear Panel Adjustment and Component Locations	11
8. Main Chassis Component Locations (Bottom View)	11
9. FM Front End(P100) Schematic Diagram and Component Locations	12
10. AM Tuner (P150) Schematic Diagram and Component Locations	13
11. FM IF (P200) Schematic Diagram and Component Locations	14
12. FM MPX (P300) Schematic Diagram and Component Locations	15
13. Ant. Muting (PU01) Schematic Diagram and Component Locations	16
14. Phono Amplifier (P400) Schematic Diagram and Component Locations	17
15. Dial Lamp (PZ01) Schematic Diagram and Component Locations	18
16. Function Lamps Assembly (PY01) Schematic Diagram and Component Locations	18
17. Monitor (PT01) Schematic Diagram and Component Locations	19
18. Pre Tone Amplifier (PE01) Schematic Diagram and Component Locations	20
19. Filter (PH01) Schematic Diagram and Component Locations	21
20. Main Amplifier (P700) Schematic Diagram and Component Locations	22
21. Power Supply (P800) Schematic Diagram and Component Locations	23
22. Dolby FM Assembly (PC01) Schematic Diagram and Component Locations	24
23. Packing	26
24. Rear Panel Adjustments and Component Locations for European Model	40
25. Main Chassis Component Locations (Bottom View) for European Model	40
26. Voltage Conversion Chart	41
27. Schematic Diagram for European Model	42

INTRODUCTION

This service manual was prepared for use by Authorized Warranty Stations and contains service information for Marantz Model 2250 Stereophonic Receiver.

Servicing information and voltage data included in this manual are intended for use by the knowledgeable and experienced technician only. All instructions should be read carefully. No attempt should be made to proceed without a good understanding of the operation of the receiver.

The parts list furnishes information by which replacement parts may be ordered from the Marantz Company. A simple description is included for parts which can usually be obtained through local suppliers.

1. P.W. Board

As can be seen from the circuit diagram the chassis of Model 2250 consists of the following units. Each unit mounted on a printed circuit board is described within the square enclosed by a bold dotted line on the circuit diagram.

1. FM Front End	Mounted on P.W. Board, P100
2. AM Tuner	Mounted on P.W. Board, P150
3. FM — IF	Mounted on P.W. Board, P200
4. MPX	Mounted on P.W. Board, P300
5. ANT. Muting VR	Mounted on P.W. Board, PU01
6. Dolby Level	Mounted on P.W. Board, PC01
7. Phono Amp.	Mounted on P.W. Board, P400
8. Dial Lamp	Mounted on P.W. Board, PZ01
9. Monitor, SW	Mounted on P.W. Board, PT01
10. Function Lamp	Mounted on P.W. Board, PY01
11. Pre Tone Amp.	Mounted on P.W. Board, PE01
12. Filter, SP SW	Mounted on P.W. Board, PH01
13. Power Amp.	Mounted on P.W. Board, P700
14. Power Supply	Mounted on P.W. Board, P800

2. TEST EQUIPMENT REQUIRED FOR SERVICING

Table 1 lists the test equipment required for servicing the Model 2250 Receiver.

Item	Manufacturer and Model No.	Use
AM Signal Generator		Signal source for AM alignment.
Test Loop		Used with AM signal generator.
FM Signal Generator	Less than 0.3% distortion	Signal source for FM alignment.
Stereo Modulator	Less than 0.3% distortion	Stereo separation alignment and trouble shooting.
Frequency Counter		MPX Oscillator adjustment (VCO).
Audio Oscillator	Weston Model CVO-100P, less than 0.02% residual distortion is required	Sinewave and squarewave signal source.
Oscilloscope	High sensitivity with DC horizontal and vertical amplifiers	Waveform analysis and trouble shooting and ASO alignment.
VTVM	With AC, DC, RF range	Voltage measurements.
Circuit Tester		Trouble shooting.
AC Wattmeter	Simpson, Model 390	Monitors primary power to amplifier.
AC Ammeter	Commercial Grade (1-10A)	Monitors amplifier output under short circuit condition.
Line Voltmeter	Commercial Grade (0-150V AC)	Monitors potential of primary power to amplifier.
Variable Autotransformer (0-140V AC, 10 amps)	Powerstat, Model 116B	Adjusts level of primary power to amplifier.
Shorting Plug	Use phono plug with 600 ohm across center pin and shell.	Shorts amplifier input to eliminate noise pickup.
Output load (8 ohms, $\pm 1\%$ 100W)	Commercial Grade	Provides 8-ohm load for amplifier output termination.
Output load (4 ohms, $\pm 1\%$ 100W)	Commercial Grade	Provides 4-ohm load for amplifier output termination.

Table 1. Test Equipment Required for Servicing

3. AM ALIGNMENT PROCEDURE

3.1 AM IF Alignment

1. Connect a sweep generator to the J153 and an alignment scope to the test point B.
2. Rotate each core of IF transformer L153 for maximum height and flat top symmetrical response.

3.2 AM Frequency Range and Tracking Alignment

1. Set AM signal generator to 515 KHz. Turn the tuning capacitor fully closed (place the tuning pointer at the low end) and adjust the oscillator coil L152 for maximum audio output.
2. Set the signal generator to 1650 KHz. Place the tuning pointer in the high frequency end and adjust the oscillator trimmer on the oscillator tuning capacitor for maximum audio output.
3. Repeat steps 1 and 2 until no further adjustment is necessary.
4. Set the generator to 600 KHz and tune the receiver to the same frequency and adjust a slug core of AM ferrite rod antenna and RF coil L151 for maximum output.

5. Set the generator to 1400 KHz and tune the receiver to the same frequency and adjust both trimming capacitors of antenna and RF tuned circuit for maximum output.
6. Repeat steps 4 and 5 until no further adjustment is necessary.

Note: During tracking alignment reduce the signal generator output as necessary to avoid AGC action.

3.3 AM Signal Strength Meter Alignment

Set an AM signal generator to 1000 KHz at $5\text{K}\mu\text{V}$, and adjust R178 so that the signal strength meter may read 90% of the full scale.

4. FM ALIGNMENT PROCEDURE

1. Connect an FM signal generator to the FM ANTENNA terminals and an oscilloscope and an audio distortion analyzer to the TAPE OUTPUT jacks on the rear panel.
2. Set the FM SG to 87 MHz and provide about 3 to $5\mu\text{V}$. Place the tuning pointer at the low frequency end by rotating the tuning knob and adjust the core of oscillator coil L104 to obtain maximum audio output.
3. Set the FM SG to 109 MHz and provide about 3 to $5\mu\text{V}$ output. Rotate the tuning knob and place the tuning pointer at the high frequency end and adjust the trimming capacitor C106 for maximum output.
4. Repeat steps 2 and 3 until no further adjustment is necessary.
5. Set the FM SG to 90 MHz and tune the receiver to the same frequency. Decrease signal generator output until the audio output level decreases with the decreasing generator output. Adjust the antenna coil L101, RF coil L102 and L103 and IF transformer L105 for minimum audio distortion.
6. Set the FM SG to 106 MHz and tune the receiver to the same frequency. Adjust the trimming capacitor C102, C104 and C105 for minimum distortion.
7. Repeat steps 5 and 6 until no further adjustment is necessary.
8. Adjust the secondary core (upper) of discriminator transformer L201 so that the center tuning meter pointer indicates its center at no signal applied. Set the FM SG to 98 MHz and increase its output level $1\text{K}\mu\text{V}$ and tune the receiver to the same frequency so that the center tuning meter pointer indicates its center.
Adjust the primary core (lower) of L201 for minimum distortion.
9. Set the FM SG to 98 MHz at $100\text{K}\mu\text{V}$, and adjust R374 so that the signal strength meter may read 90% of the full scale.

5. STEREO SEPARATION ALIGNMENT

1. Set the FM SG to provide $1\text{K}\mu\text{V}$ at 98 MHz. Tune the receiver to the same frequency so that the center tuning meter pointer indicates its center.
2. Turn the FM SG modulation off (with the pilot signal turned off), connect a frequency counter to test point J310, and adjust R311 so that the frequency counter may precisely read 19 KHz.
3. Modulate the FM SG with stereo composite signal consisting only of subchannel signal (of course a pilot signal must be included).
4. Adjust the trimming resistor R301 for maximum and same separation in both channels.

6. MUTING CIRCUIT ALIGNMENT

1. Connect a VTVM across the resistor R363 and adjust the resistor R363 until the meter reads 0.75V DC at no signal.
2. Set the FM SG to provide $1\text{K}\mu\text{V}$ at 98 MHz and tune the receiver to the same frequency correctly.
3. Turn on MUTING push switch. Shift the FM signal generator frequency to plus and minus and note both plus and minus shifted frequencies at which undesirable audio side responses are muted out. Adjust the R363 so that the same shifted frequencies mute the undesirable side response.

4. Adjust R362 for proper frequency shift at which the muting circuit operates.

7. DOLBY FM TAPE OUTPUT SETTING

1. Set the modulation of FM SG to 400 Hz, 50% (± 37.5 KHz Dev.)
2. Set the FM SG to provide 1 K μ V at 98 MHz. Tune the receiver to the same frequency so that the center tuning meter pointer indicates its center.
3. Turn on DOLBY FM push switch. Set the semifixed resistors RC01 and RC02 so that the output of the TAPE OUTPUT terminals R and L become 580 mV at VTVM.

8. AUDIO ADJUSTMENT

1. Voltage adjustment
Connect a DC voltmeter between pin terminal 804 and 805, and adjust the trimming resistor R806 for 35V DC.
2. Main Amplifier DC off-set alignment
Connect a DC voltmeter with 0.5 or 1V range between the speaker terminals and adjust the trimming resistor R707 for "zero" DC output on the meter.
Repeat the same procedure for the other channel.
Note: During this alignment no load should be connected to the speaker terminals.
3. Idle-current adjustment
Connect a VTVM between pin terminals 708 and 710. Next, adjust the trimming resistor R719 so the VTVM reads 8mV DC. Repeat the same procedure for the other channel.
4. Check DC off-set voltage aligned in the procedure 2 and if any DC output is observed on the DC voltmeter, adjust the R707 again for "zero" output.
5. Phono-amplifier adjustment
Connect an oscilloscope to the TAPE OUT jacks and an audio signal generator to the PHONO jacks. Place the selector switch in the PHONO position. Increase 1 KHz audio signal gradually until a slight clipping on top of the sine-wave is observed on the oscilloscope. Adjust the trimming resistor R408 for equal clipping level.
For the other channel adjust R409.

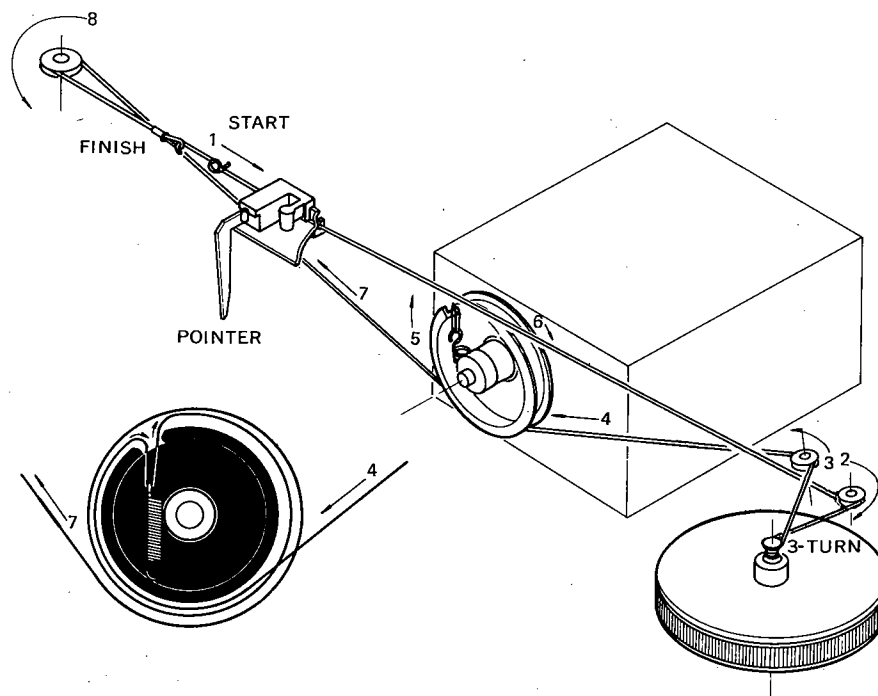

Figure 1. Dial Stringing

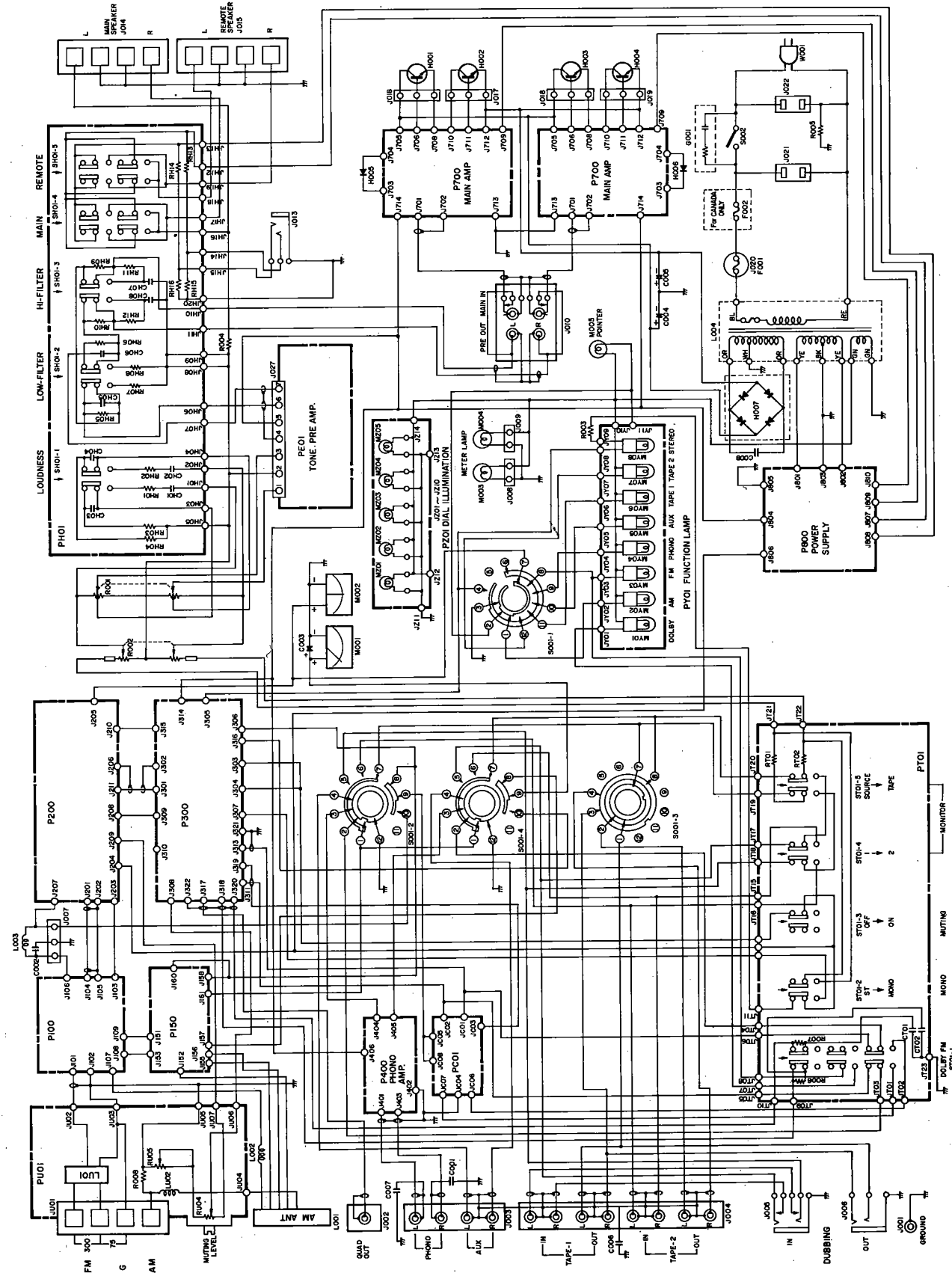
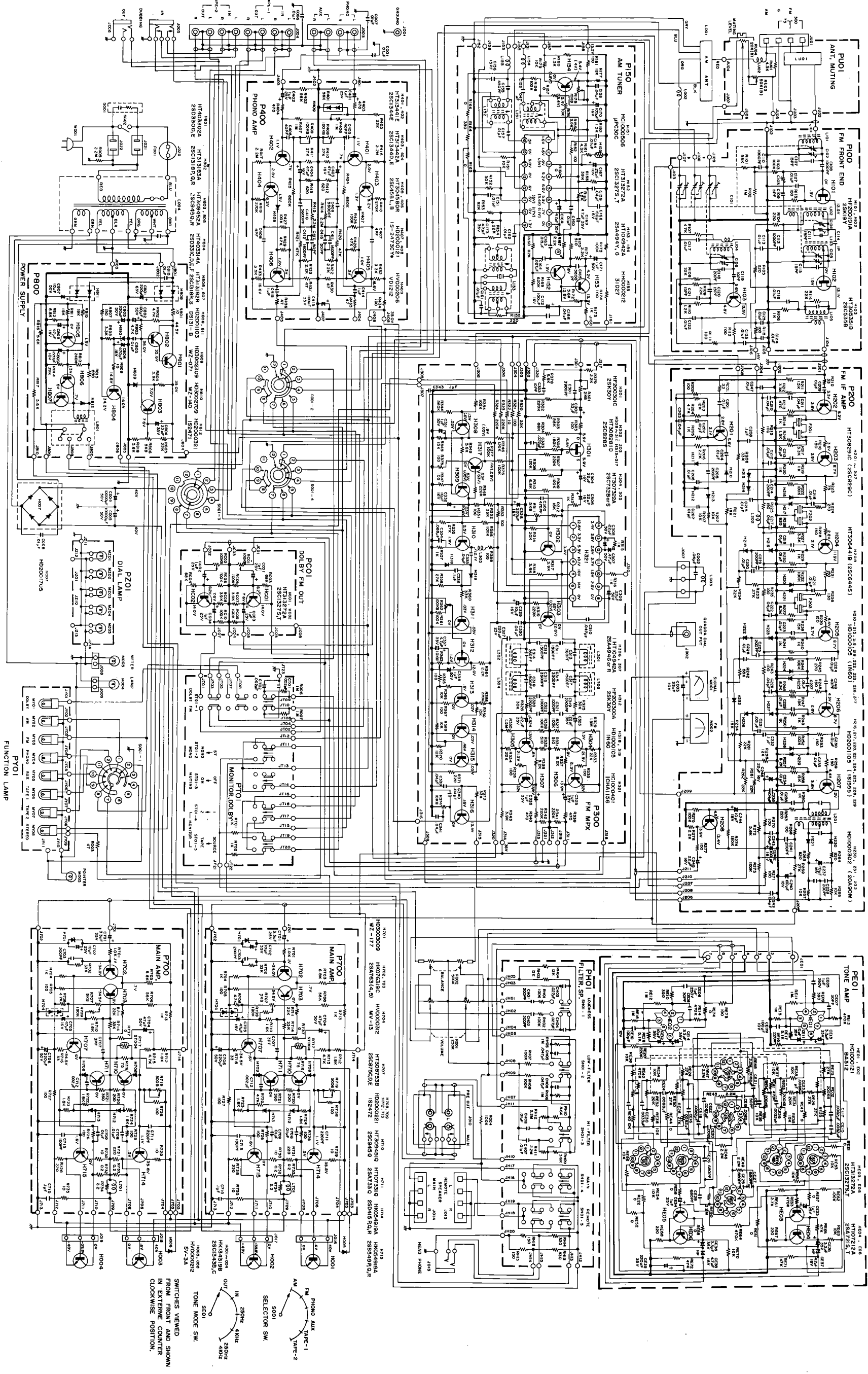

Figure 2. Wiring Diagram



Model 2250 NOTE: This schematic diagram applies to units manufactured for the U.S.A. market.

Figure 3. Schematic Diagram

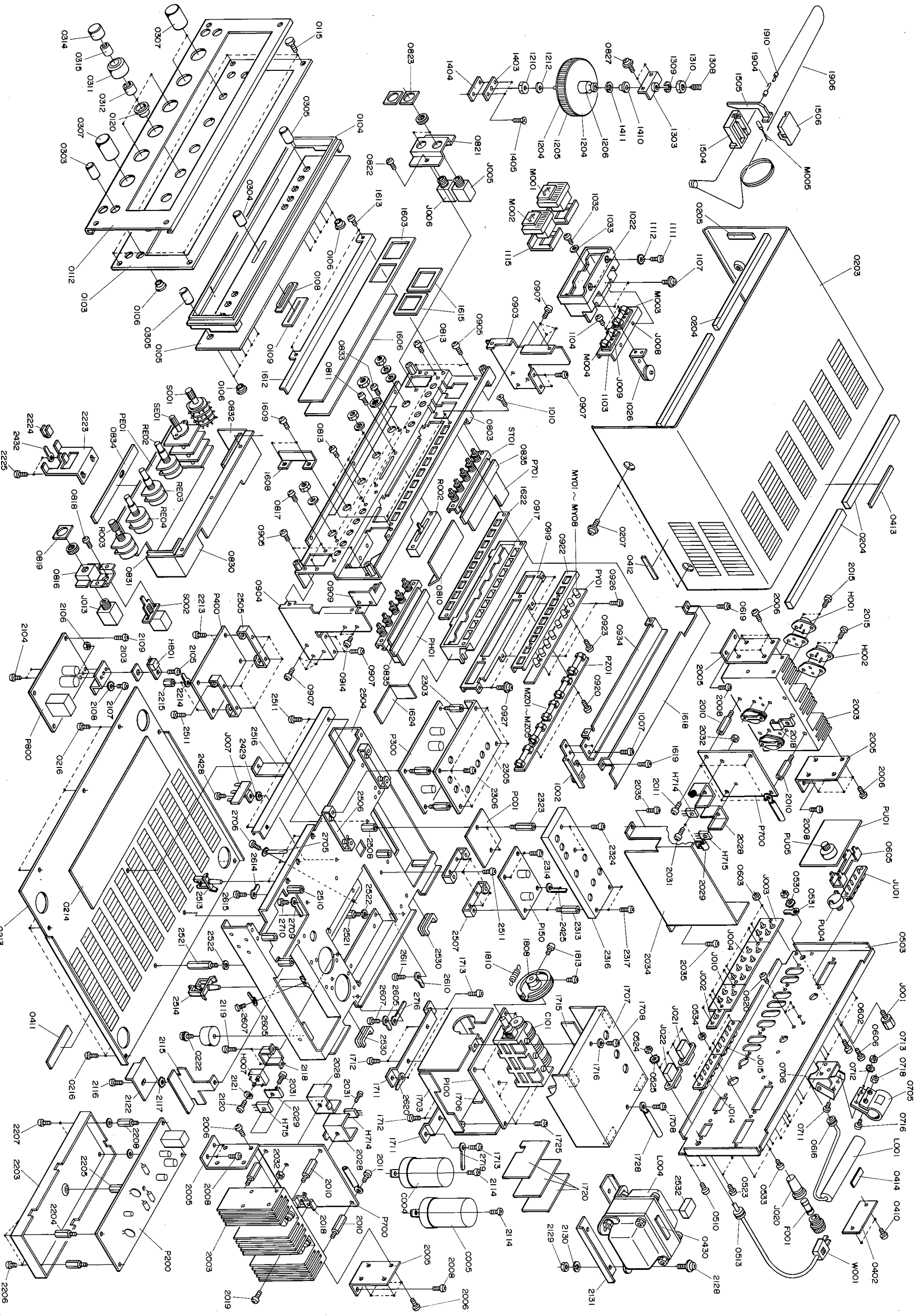

Figure 4. Exploded Mechanical Diagram

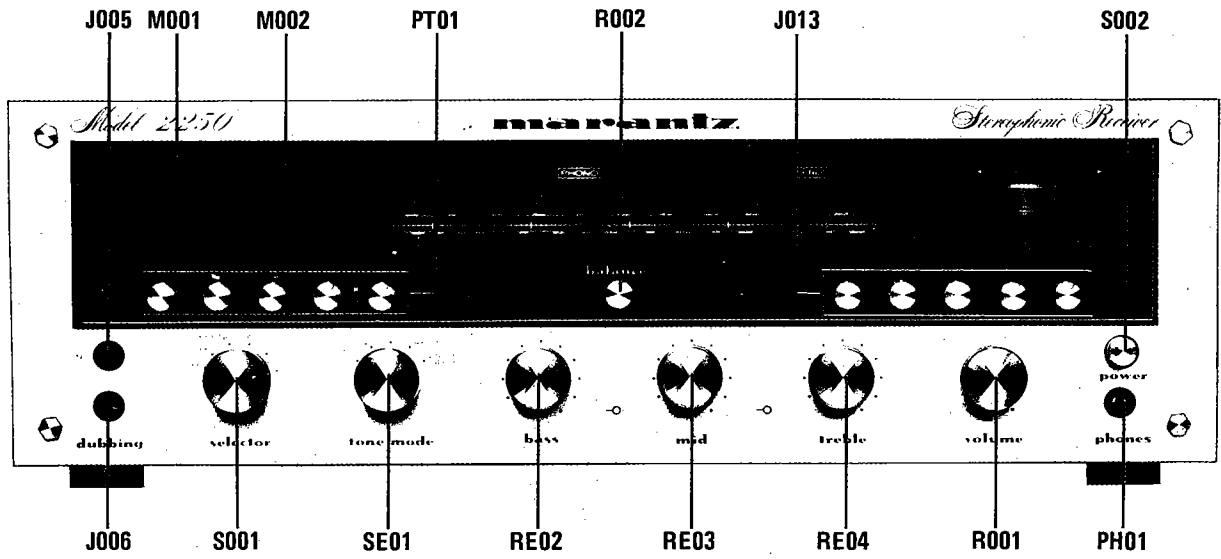

Figure 5. Front Panel Adjustments and Component Locations

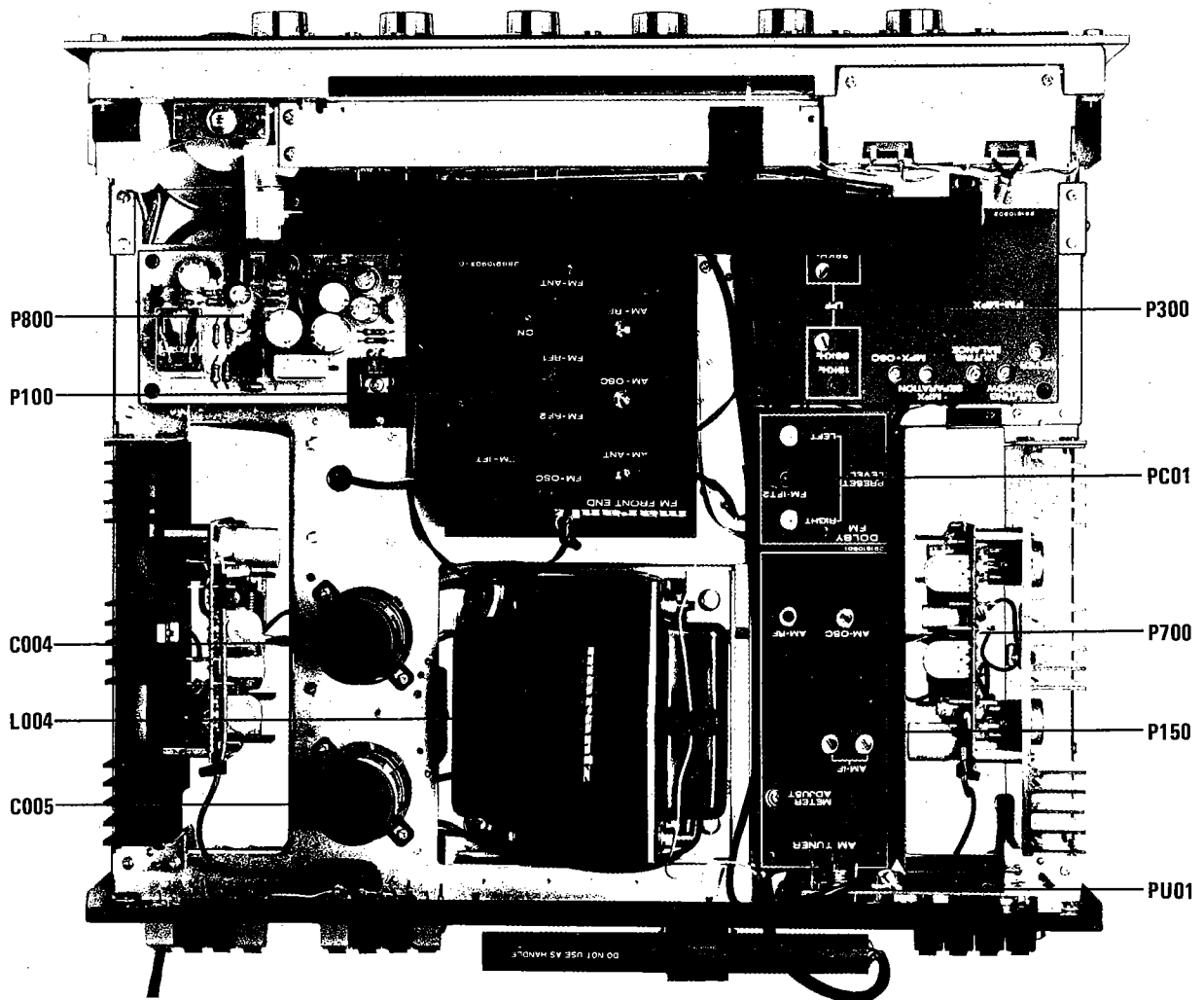

Figure 6. Main Chassis Component Locations (Top View)

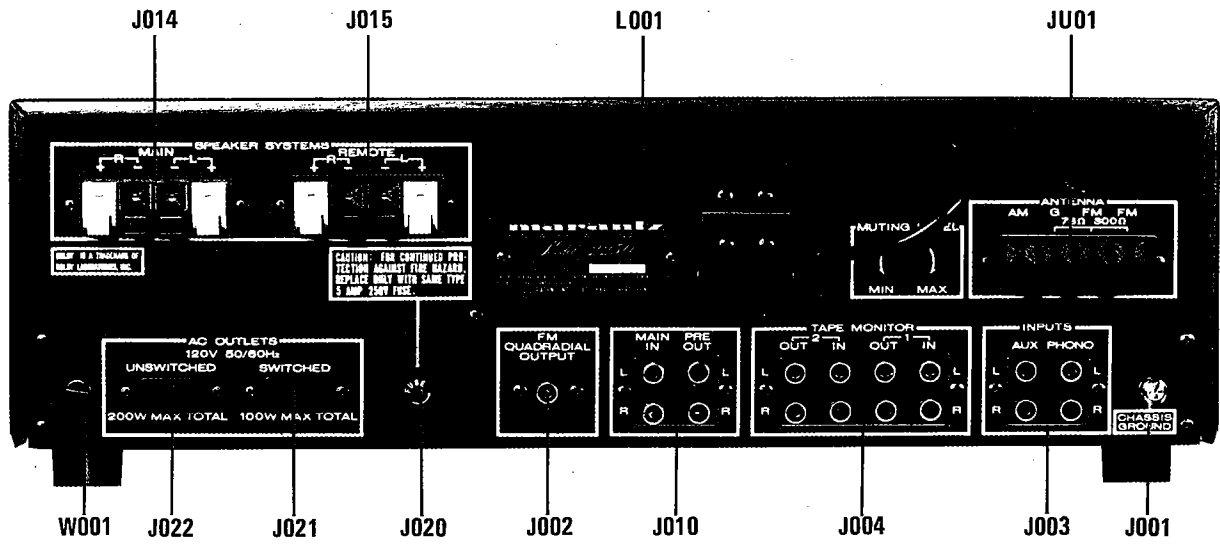

Figure 7. Rear Panel Adjustment and Component Locations

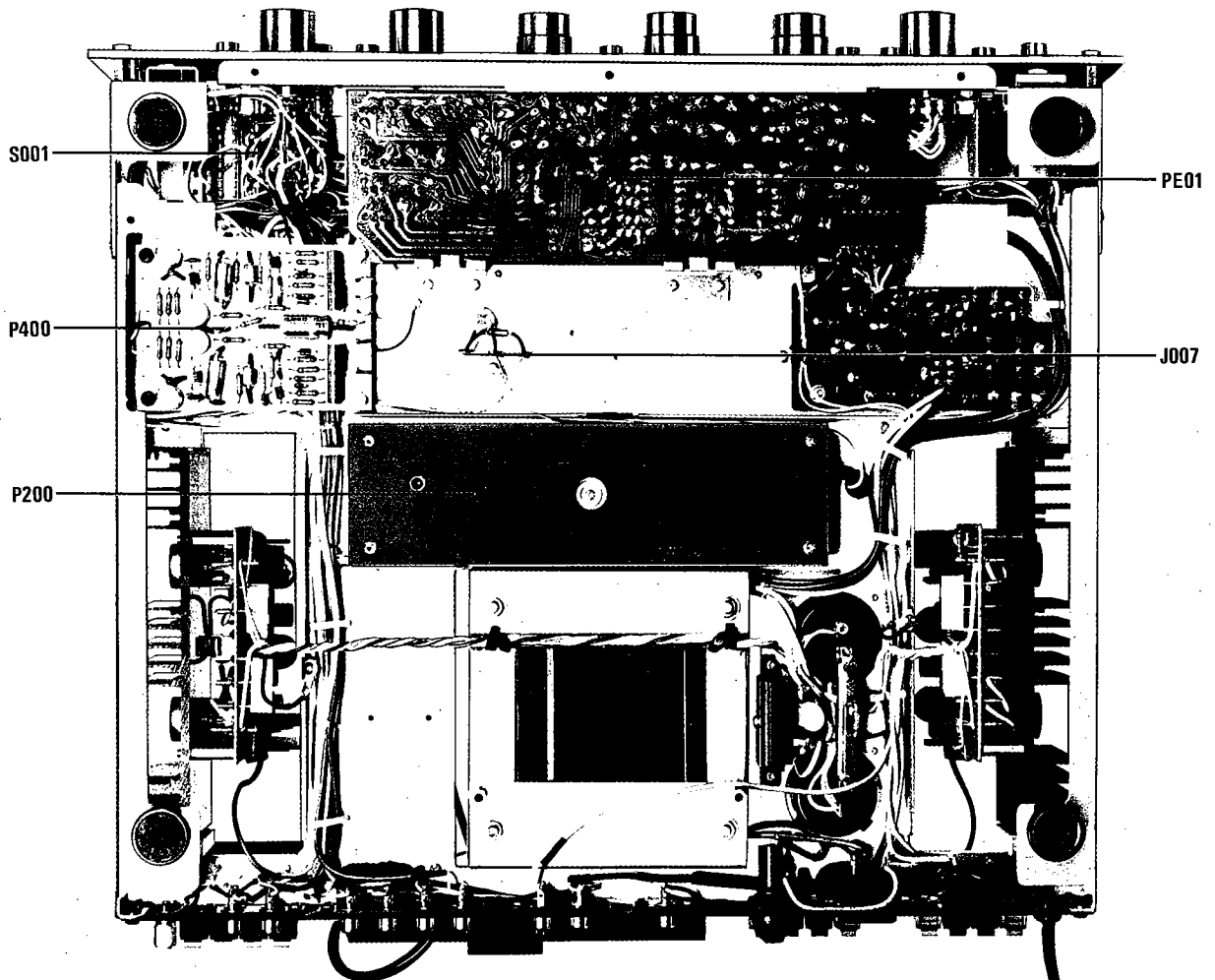

Figure 8. Main Chassis Component Locations (Bottom View)

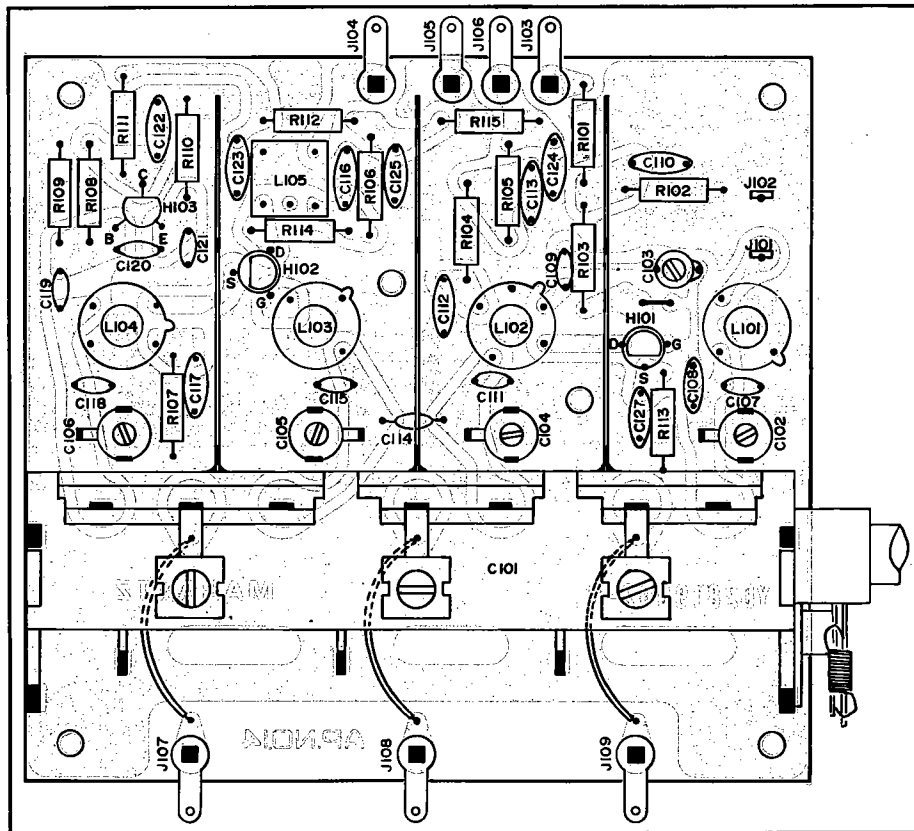
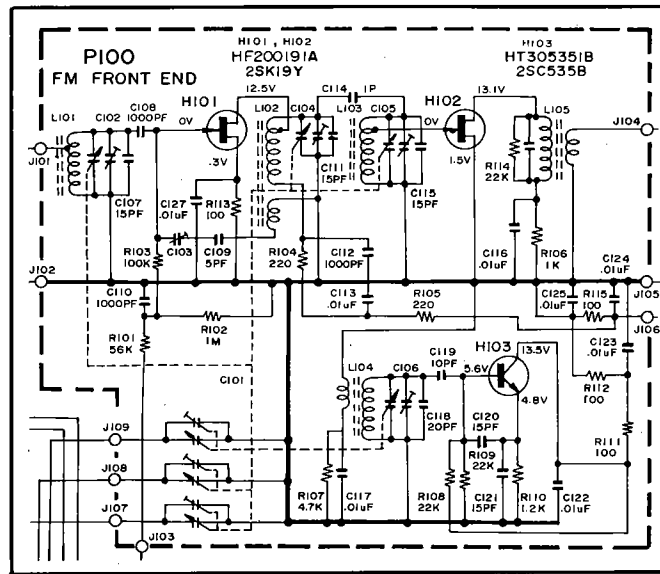

Figure 9. FM Front End(P100) Schematic Diagram and Component Locations

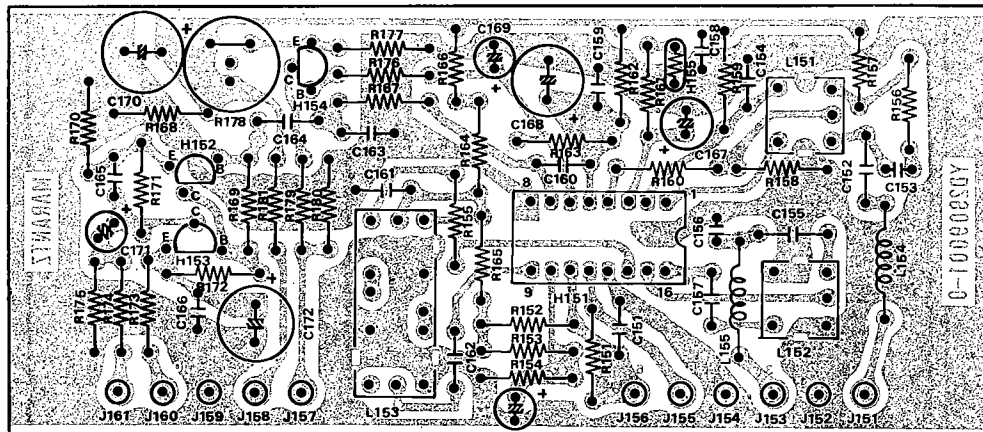
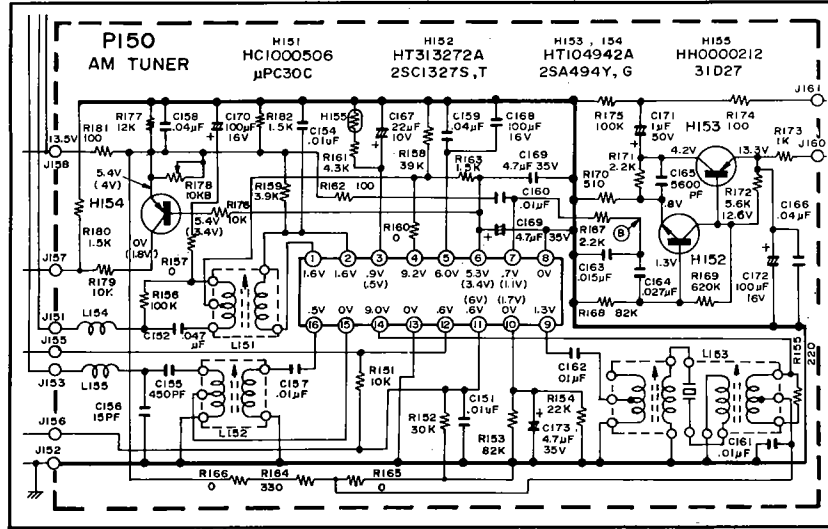

Figure 10. AM Tuner (P150) Schematic Diagram and Component Locations

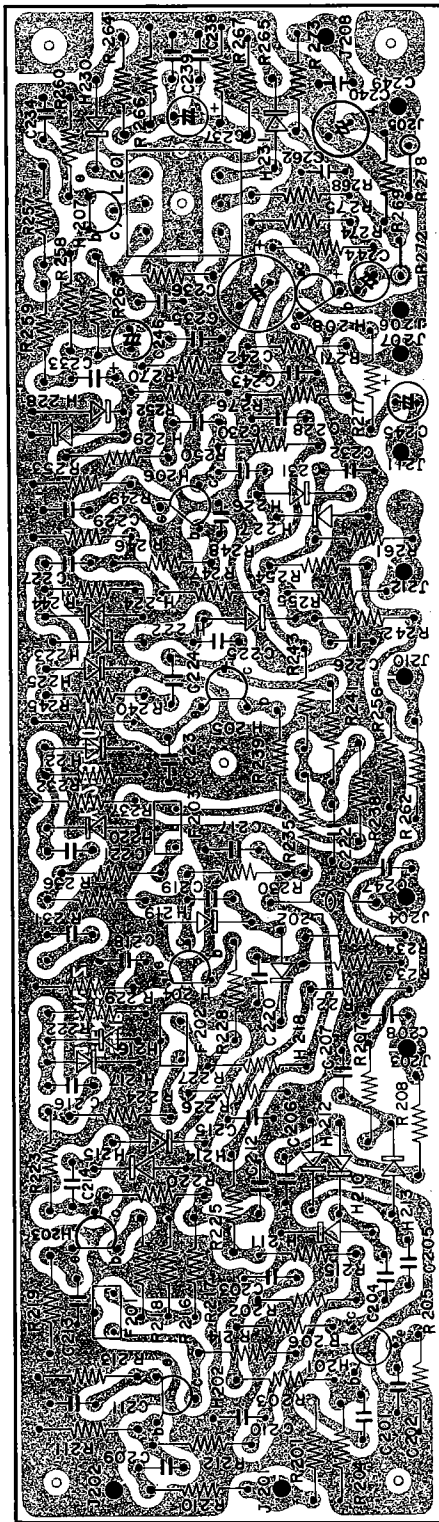
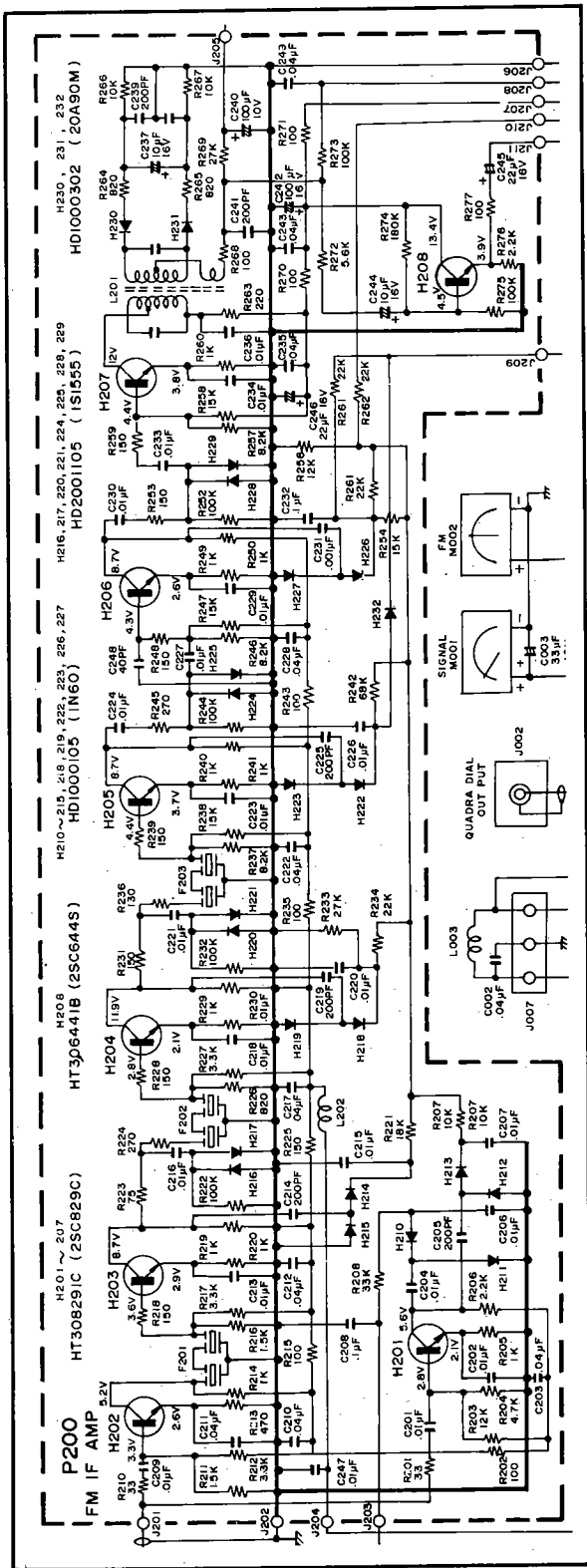

Figure 11. FM IF (P200) Schematic Diagram and Component Locations

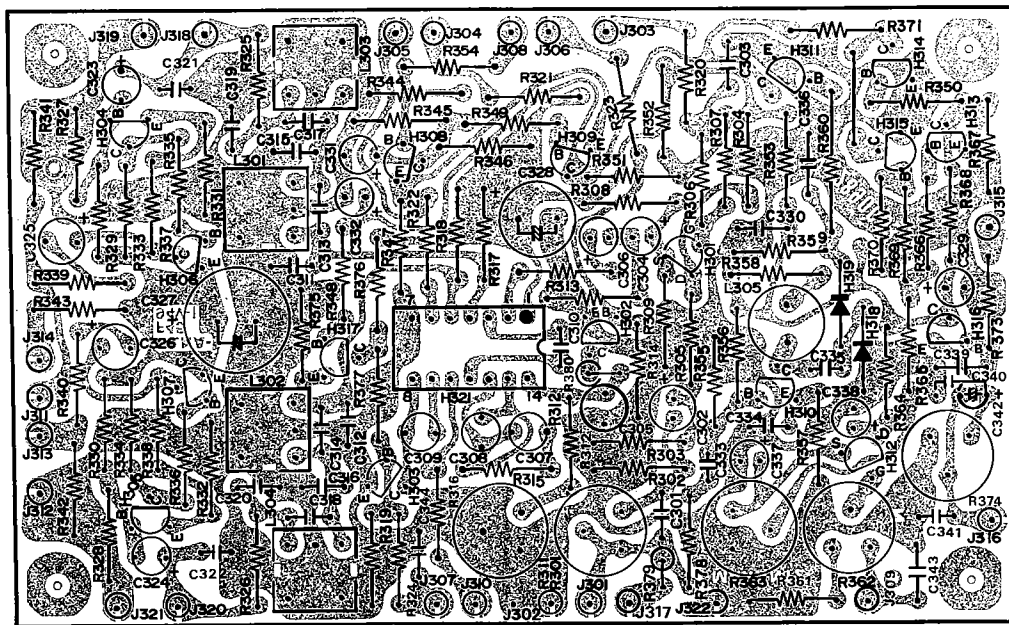
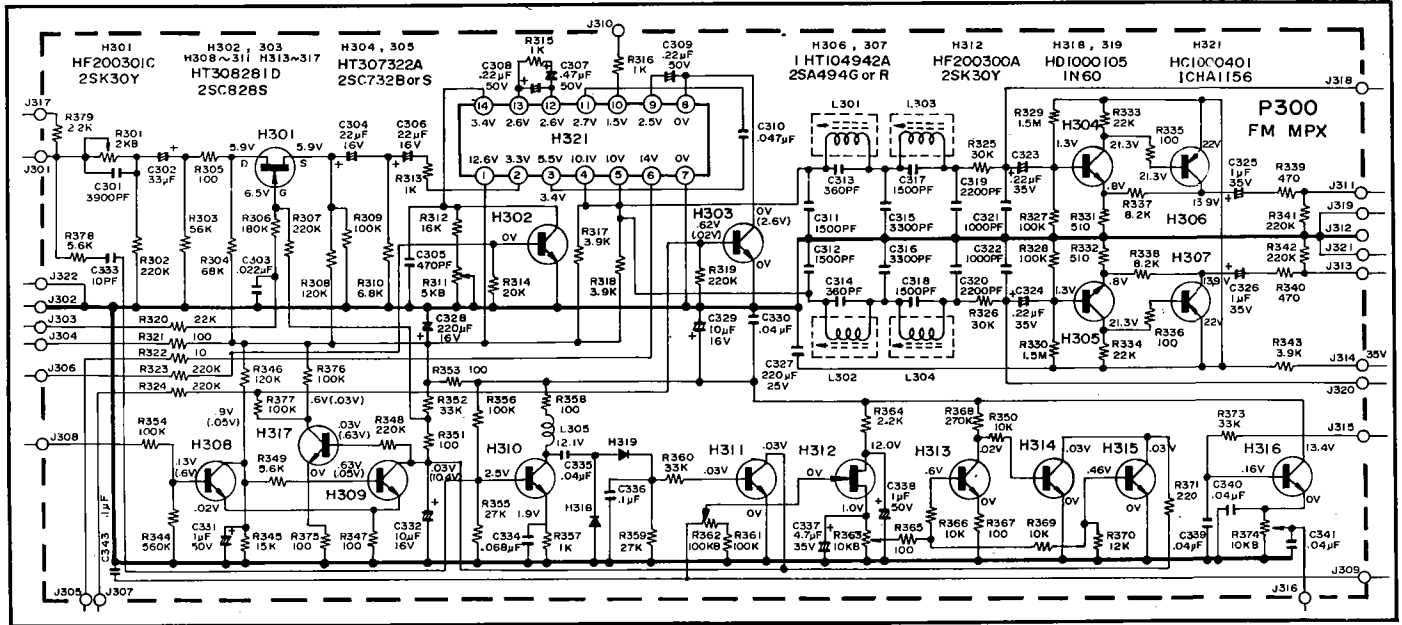

Figure 12. FM MPX (P300) Schematic Diagram and Component Locations

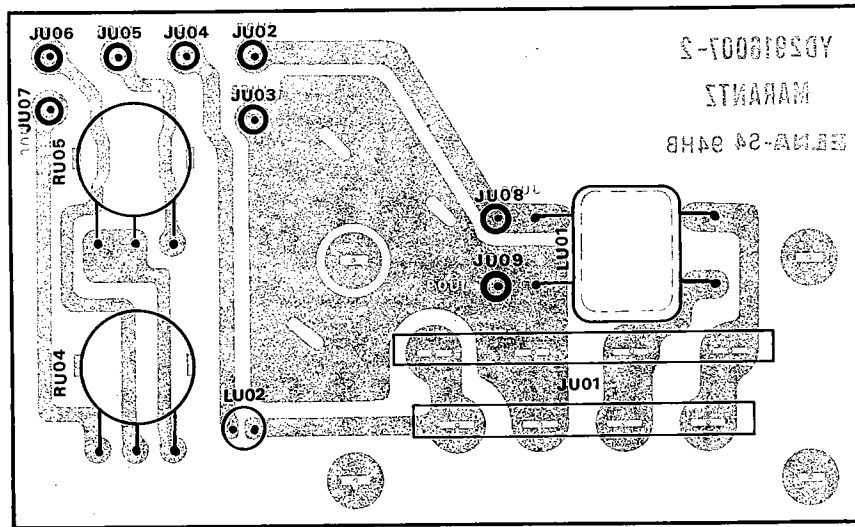
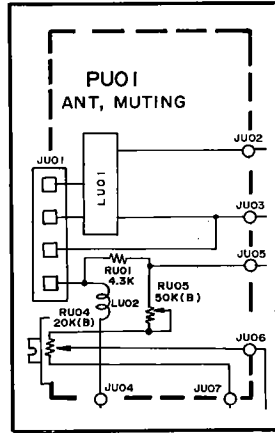

Figure 13. Ant. Muting (PU01) Schematic Diagram and Component Locations

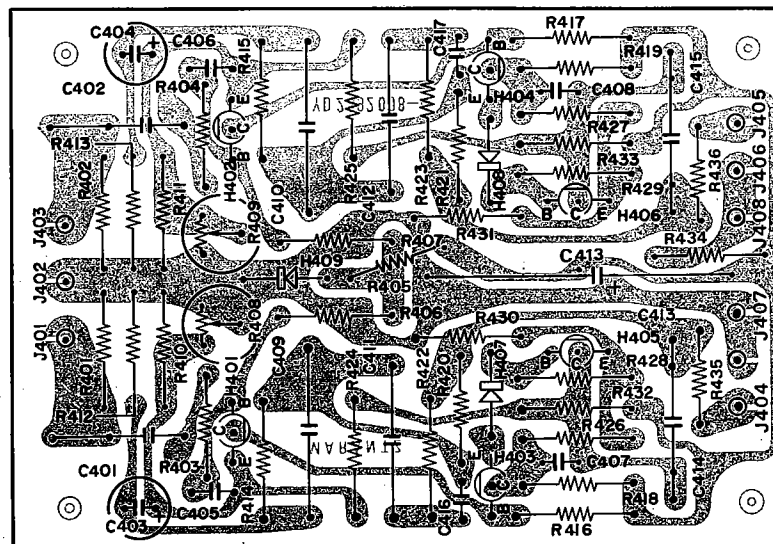
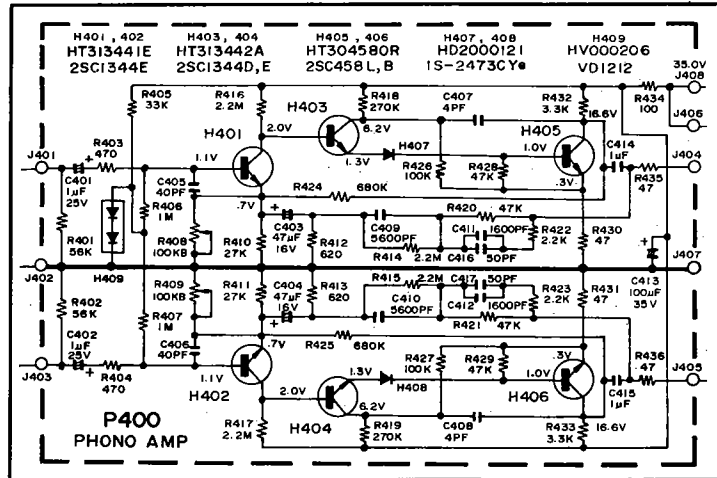

Figure 14. Phono Amplifier (P400) Schematic Diagram and Component Locations

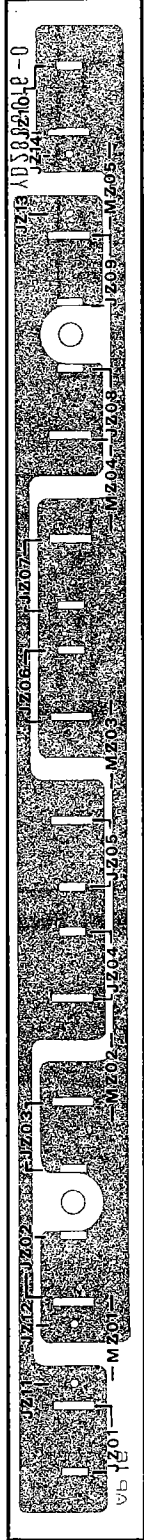
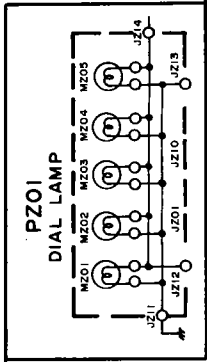

Figure 15. Dial Lamp (PZ01) Schematic Diagram and Component Locations

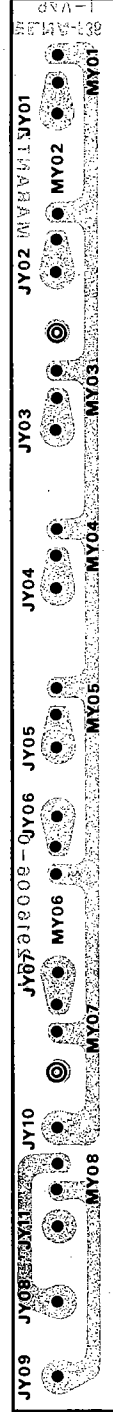
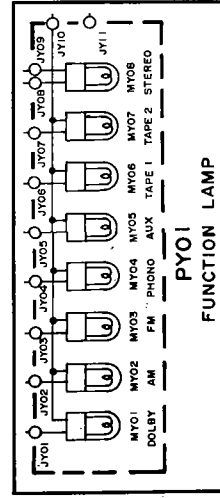

Figure 16. Function Lamps Assembly (PY01) Schematic Diagram and Component Locations

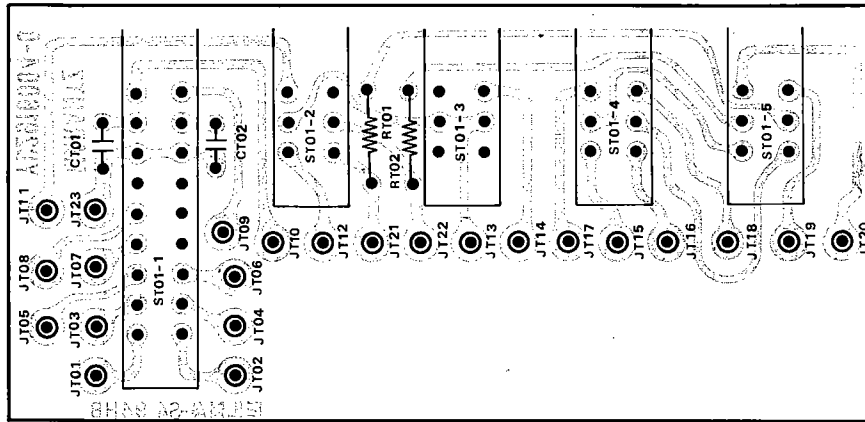
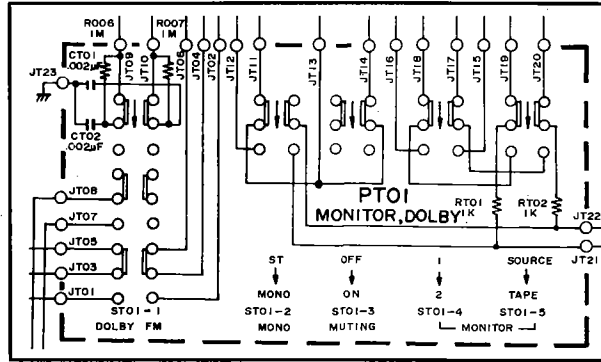

Figure 17. Monitor (PT01) Schematic Diagram and Component Locations

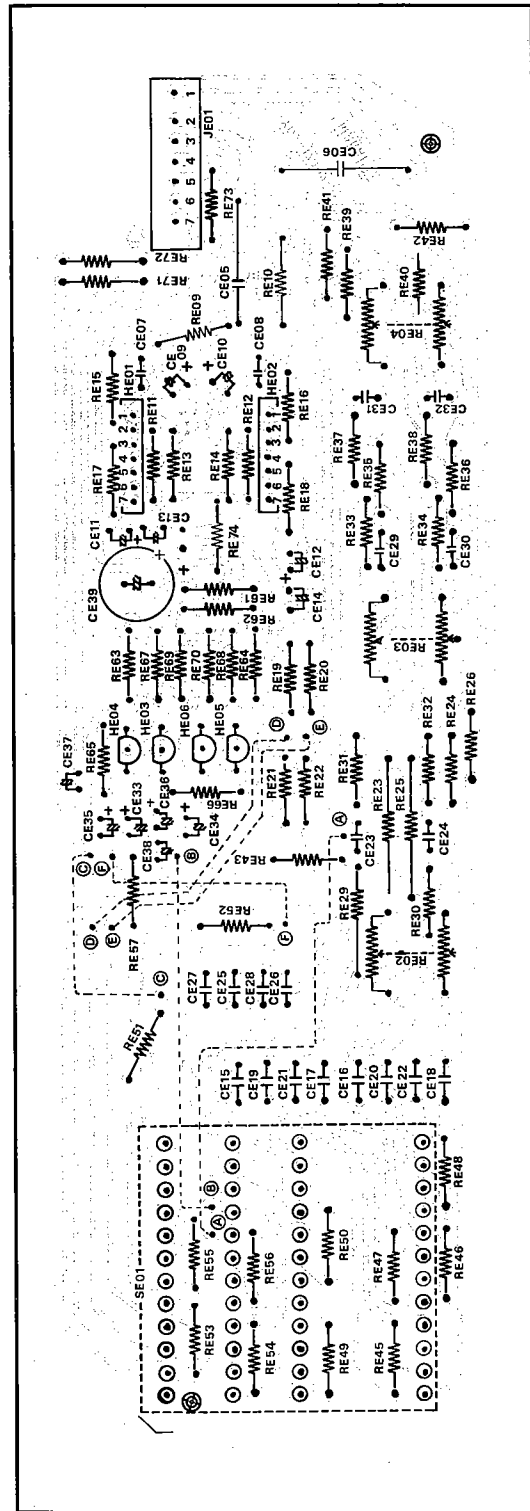
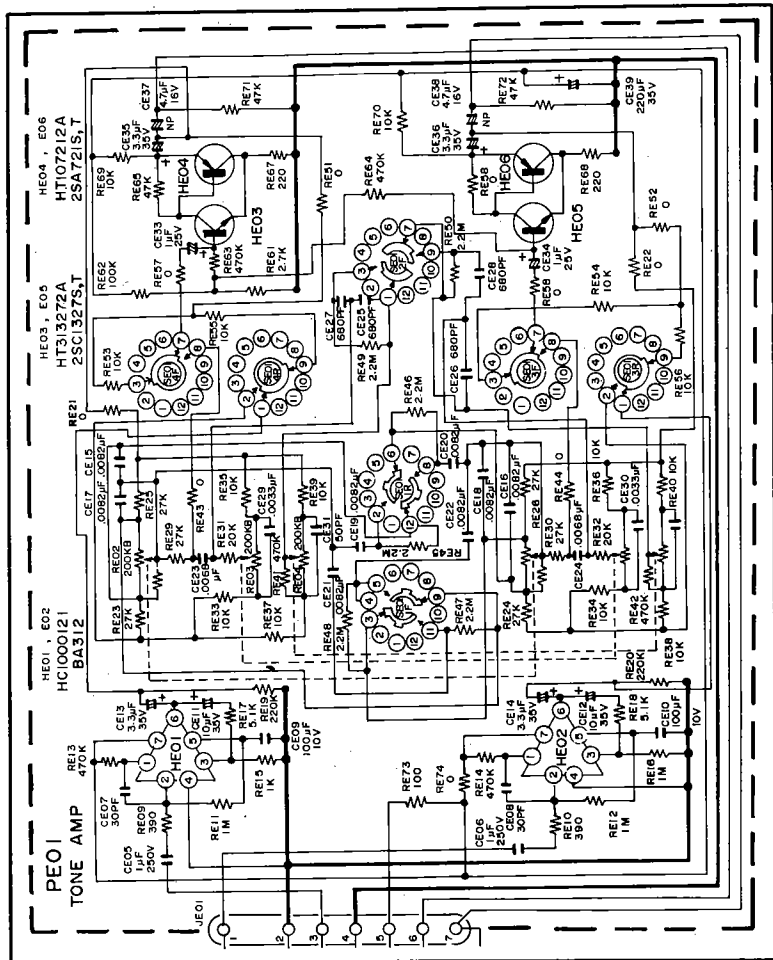

Figure 18. Pre Tone Amplifier (PE01) Schematic Diagram and Component Locations

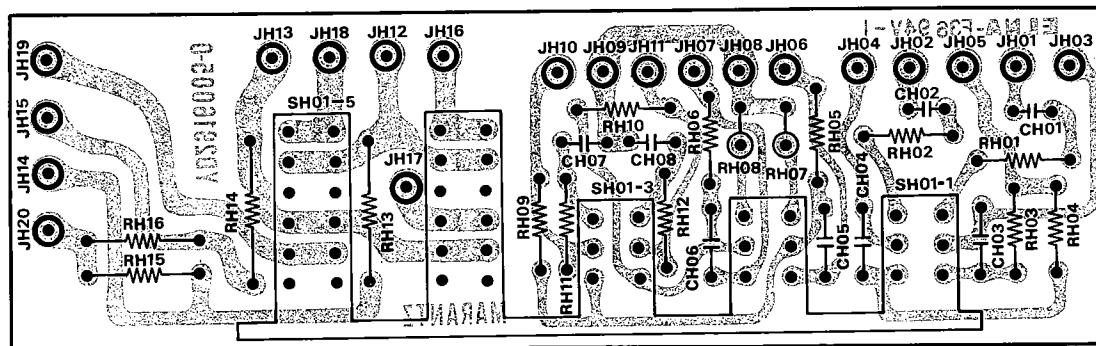
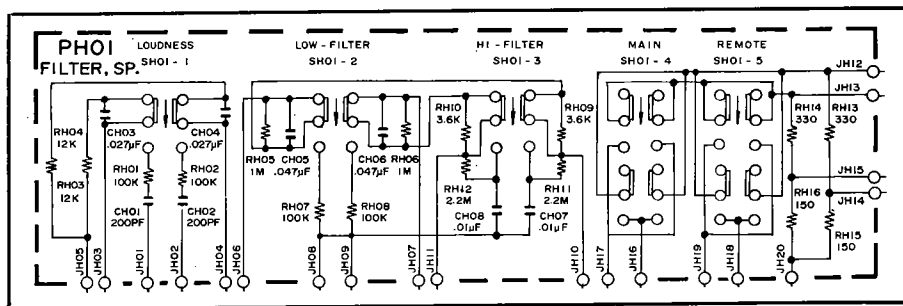

Figure 19. Filter (PH01) Schematic Diagram and Component Locations

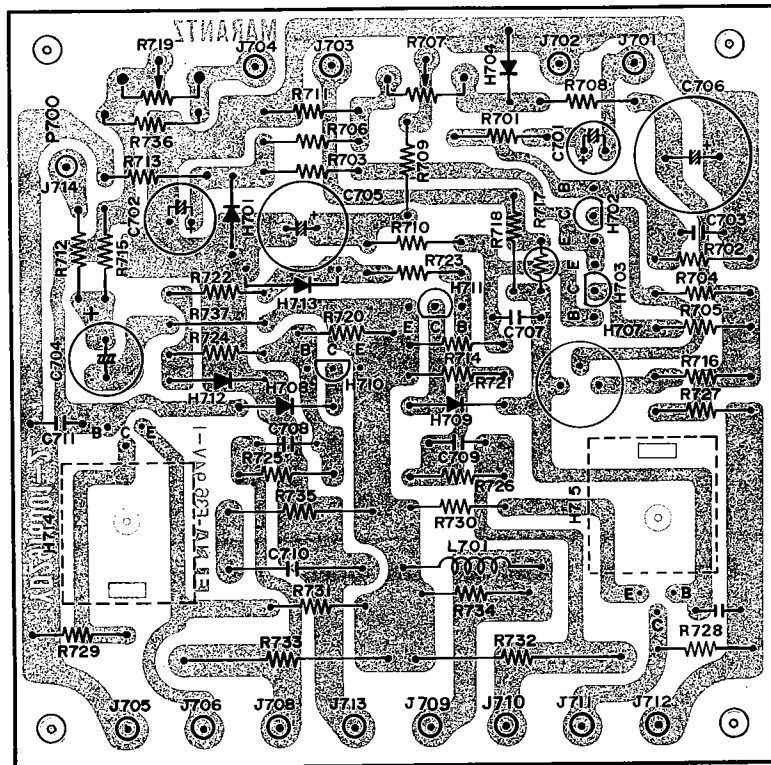
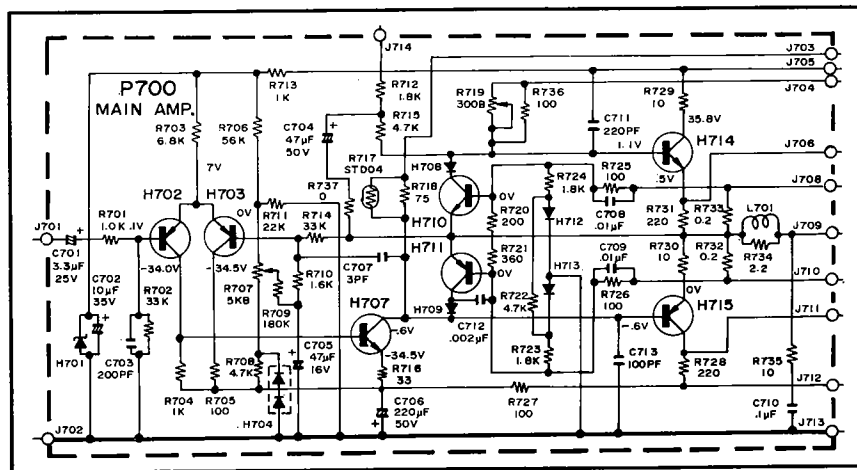

Figure 20. Main Amplifier (P700) Schematic Diagram and Component Locations

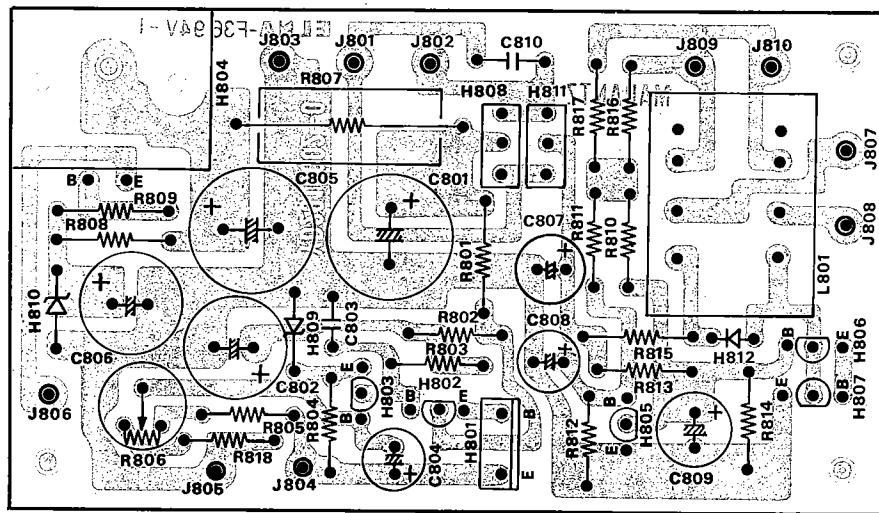
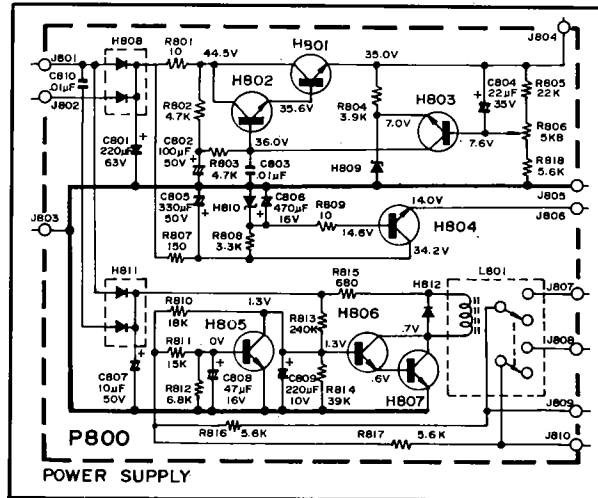

Figure 21. Power Supply (P800) Schematic Diagram and Component Locations

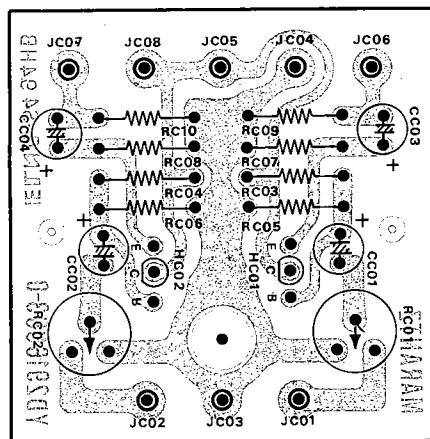
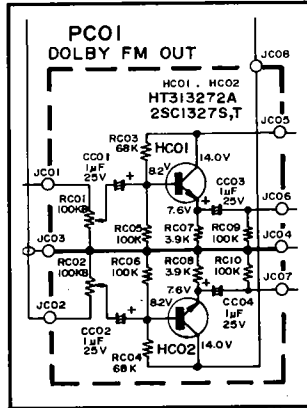

Figure 22. Dolby FM Assembly (PC01) Schematic Diagram and Component Locations

TECHNICAL SPECIFICATIONS

Amplifier Section:

RATED POWER OUTPUT	50 Watts per channel, Continuous Average Power, both channels driven.
Power Band	20 Hz to 20 kHz
Total Harmonic Distortion	0.25%
Load Impedance	8 ohms
Intermodulation Distortion at Rated Power	0.3%
Damping Factor	55
Frequency Response	20 Hz to 20 kHz ± 0.5 dB

Preamplifier Sections:

Phono:

Dynamic Range	96 dB
NOTE: Dynamic Range is the ratio in dB of the phono input overload to equivalent input noise.	
Equivalent Input Noise	1.5 μ V
Input Overload	100 mV
Sensitivities (for rated power output)	
Phono	1.8 mV
Tape	180 mV
Main In	1.5 V
Frequency Response (phono)	30 Hz to 15 kHz ± 1.0 dB

Input Impedances

Phono	47 K ohms
Aux or Tape	100 K ohms
Main In	30 K ohms

Tape Output Level	775 mV
Ref: 7.75 mV at phono input	

Signal to Noise Ratio

Aux Input	85 dB
Phono Input	75 dB

Tone Controls

Bass: 100 Hz	± 10 dB
Tone Mode at 250 Hz	± 3 dB
Mid: 700 Hz	± 7.5 dB
Treble: 10 kHz	± 10 dB
Tone Mode at 4 kHz	± 3 dB

FM Tuner Section:

IHF Usable Sensitivity	2.5 μ V
Selectivity (alternate carrier)	60 dB
Quieting Slope	
RF Input for 30 dB Quieting	1.9 μ V
Quieting at 5 μ V RF Input	55 dB
Quieting at 10 μ V RF Input	60 dB
Quieting at 50 μ V RF Input	70 dB

Total Harmonic Distortion	
Mono:	0.3%
Stereo:	0.4%
Capture Ratio	1.5 dB
Stereo Separation at 1 kHz	40 dB
Spurious Rejection	95 dB
Image Rejection	70 dB
IF Rejection	90 dB
AM Suppression	55 dB

AM Tuner Section:

Sensitivity	20 μ V
-------------------	------------

General:

Power Requirements	120 V AC, 50/60 Hz
Power Consumption at rated output, both channels operating	220 Watts
Idling Power (Volume Control at zero)	35 Watts
Dimensions:	
Panel Width	17-3/8 inches
Panel Height	5-3/8 inches
Depth	14-3/8 inches
Weight:	
Unit Alone	34.1 lbs
Packed for Shipment	40.7 lbs

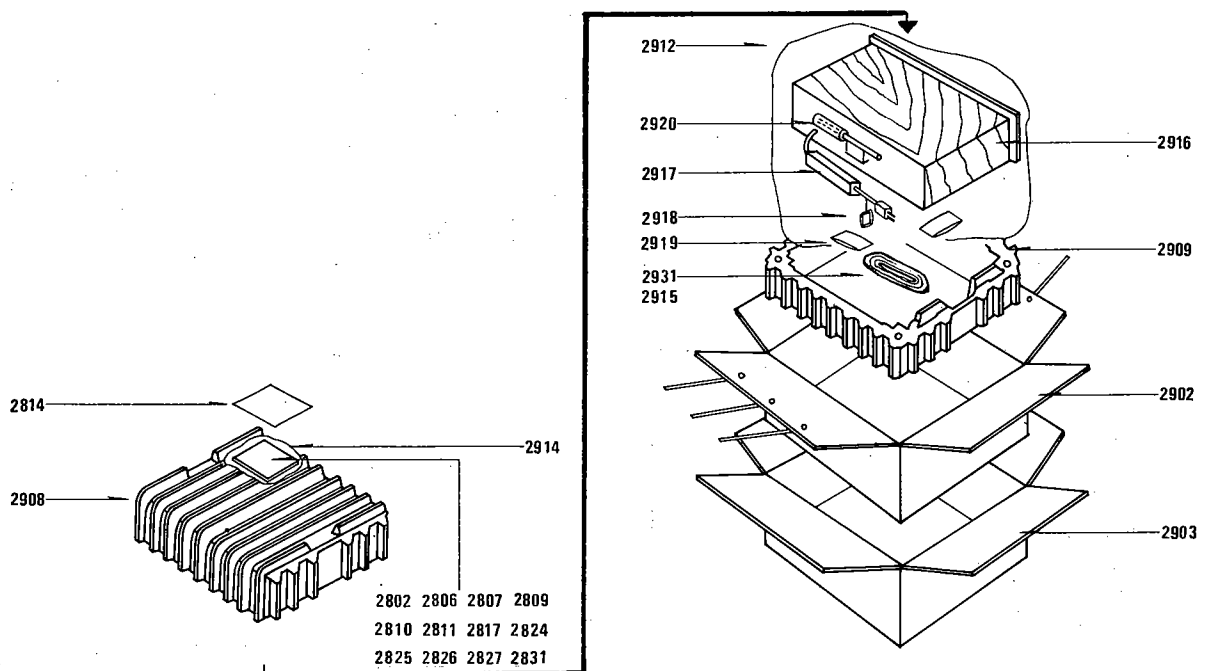

Figure 23. Packing

U: For U.S.A.
C: For Canada
E: For Europe

Parts List

REF. DESIG.	QTY.			PART NO.	DESCRIPTION
	U	C	E		
A	1	1	1	292806340	Front Panel Assembly
0103	1	1	1	292806301	Escutcheon
0104	1	1	1	285340101	Frame
0105	1	1	1	291615801	Window
0106	11	11	11	288625901	Bush
0108	1	1	1	285425901	Bush
0109	1	1	1	291510701	Sheet
0112	1	1	1	292805301	Cover
B	1	1	1	285327340	Fly Wheel Assembly
1204	2	2	2	257706302	Escutcheon
1205	1	1	1	257727301	Fly Wheel
1206	1	1	1	285311201	Shaft
1210	1	1	1	53110603E	Hexagon Nut
1212	1	1	1	54020601E	Flat Washer P
C	1	1	1	291510340	Pointer Assembly
1504	1	1	1	291510301	Pointer
1505	1	1	1	281810302	Pointer
1506	1	1	1	291510302	Pointer
M005	1	1	1	IN1008030	Lamp
D	1	1	1	120200640	Hook Assembly
1904	1	1	1	120225801	Hook
1906	1	1	1	72080802A	String
E	1	1	1	281915943	Drum Assembly
1808	1	1	1	281915901	Drum
1810	1	1	1	71101689L	Spring
1813	2	2	2	51064019A	Set Screw H.P.
F	1	1	1	291625740	Lid Assembly, Top
0203	1	1	1	291625701	Lid
0204	5	5	5	257711807	Spacer
0205	4	4	4	285605601	Buffer
0206	1	1	1	291705601	Buffer
G	1	1	1	291625741	Lid Assembly, Bottom
0213	1	1	1	291625702	Lid
0214	1	1	1	291512001	Insulator
H	3	3	3	281815440	Knob Assembly
0311	3	3	3	281815404	Knob
0312	3	3	3	71400149Q	Spring
I	3	3	3	281815441	Knob Assembly
0314	3	3	3	281815405	Knob
0315	3	3	3	71400159Q	Spring
J			1	291716040	Rear Panel Assembly
0505			1	291716022	Bracket
0514			1	284906702	Cap
0516			1	282125901	Bush
0517			2	55060305S	T.R. Rivet
0115	4	4	4	52017039J	Bolt
0120	1	1	1	291605501	Collar
0207	4	4	4	51480406S	B H M Screw F, 4 X 6
0216	10	10	10	51100406S	B H M Screw, 4 X 6
0221	4	4	4	293205701	Leg
0222	4	4	4	51440410S	B H M Screw F, 4 X 10
0303	1	1	1	290415404	Knob
0304	1	1	1	285015401	Knob
0305	10	10	10	288615403	Knob
0307	3	3	3	281815403	Knob
0402	1			292826501	Indicator

REF. DESIG.	QTY.			PART NO.	DESCRIPTION
	U	C	E		
0403			1	292826502	Indicator
0404			1	292826503	Indicator
0405				292826504	Indicator
0410	2	2	2	51060305S	B H M Screw, 3 X 5
0411	1	1	1	257886101	Label, Caution
0412	1	1	1	293286101	Label, Do Not Remove ----
0414	1	1	1	250626506	Indicator, Do Not Use As ----
0417	1	1	1	281826506	Indicator, Same As Line ----
0418	1	1	1	284626501	Indicator, SW, G, FM, AM
0419			1	951091101	Label, LL No.
0420			1	282186102	Label, Fuse Caution
0421	1			951091102	Label, Factory No.
0424	1			951110102	Label, UL
0430	1	1	1	288686101	Label, On Power Transformer
0431			1	951022101	Label, Fuse Caution, inside of set
0432			1	951061105	Label, Fuse 4A
0503	1	1		291716001	Bracket
0510	6	6	6	51100306S	B H M Screw, 3 X 6
0513	1	1		145525903	Bush
0518			2	54050300R	T L Washer OR
0519			2	51060316A	P H M Screw, 3 X 16
0520	2	2	2	53110303A	Hexagon Nut
0523	4	4	4	51060308S	B H M Screw, 3 X 8
0524	4	4	4	53110303A	Hexagon Nut
0525	4	4	4	54050300R	T L Washer OR
0530	1	1	1	54050400R	T L Washer OR
0531	1	1	1	62041760W	Lug
0533	4	4	4	51060308S	B H M Screw, 3 X 8
0534	4	4	4	53110303A	Hexagon Nut
0602	8	8	8	51106308S	B H M Screw, 3 X 8
0603	8	8	8	53110303A	Hexagon Nut
0605	1	1	1	291616005	Bracket
0606	2	2	2	51060306S	B H M Screw, 3 X 6
0616	1	1	1	145525903	Bush
0620	3	3	3	51100306S	B H M Screw, 3 X 6
0705	1	1	1	281927103	Holder
0706	1	1	1	257816052	Bracket K
0711	2	2	2	51060310S	B H M Screw, 3 X 10
0712	2	2	2	54050300R	T L Washer OR
0713	2	2	2	53110303E	Hexagon Nut
0716	2	2	2	51060310S	B H M Screw, 3 X 10
0718	2	2	2	53110303E	Hexagon Nut
0803	1	1	1	291516050	Bracket K
0810	1	1	1	291512002	Insulator
0811	2	2	2	51100306A	B H M Screw, 3 X 6
0813	4	4	4	51100306A	B H M Screw, 3 X 6
0816	1	1	1	291616003	Bracket
0817	2	2	2	51100306A	B H M Screw, 3 X 6
0818	2	2	2	51060306A	B H M Screw, 3 X 6
0819	1	1	1	289610701	Sheet
0821	1	1	1	291616002	Bracket
0822	2	2	2	51100306A	B H M Screw, 3 X 6
0823	2	2	2	289610701	Sheet
0827	2	2	2	51490306A	B H M Screw FS, 3 X 6
0830	1	1	1	291710903	Shield
0831	1	1	1	291512003	Insulator
0832	1	1	1	288912005	Insulator
0833	3	3	3	51100305A	B H M Screw, 3 X 5
0834	1	1	1	291712001	Insulator
0835	2	2	2	291612001	Insulator
0903	1	1	1	281816003	Bracket
0904	1	1	1	281816004	Bracket

U: For U.S.A.
C: For Canada
E: For Europe

REF. DESIG.	QTY.			PART NO.	DESCRIPTION
	U	C	E		
0905	4	4	4	51100406A	B.H.M. Screw, 4 x 6
0907	10	10	10	51570306B	P.H. Tapped Screw, 3 x 6
0909	1	1	1	291626251	Pulley K
0914	2	2	2	51100305A	B.H.M. Screw 3 x 5
0917	1	1	1	287127401	Reflector
0919	1	1	1	287127101	Holder
0920	2	2	2	51570306B	P.H. Tapped Screw, 3 x 6
0922	1	1	1	288627101	Holder
0923	2	2	2	51570306B	P.H. Tapped Screw, 3 x 6
0926	2	2	2	51100306A	B.H.M. Screw, 3 x 6
0927	2	2	2	51480306A	B.H.M. Screw F, 3 x 6
0934	1	1	1	287105102	Guide
1002	1	1	1	291626250	Pulley K
1007	2	2	2	51100305A	B.H.M. Screw, 3 x 5
1010	2	2	2	51042608A	F.H.M. Screw, 6 x 8
1022	1	1	1	288627401	Reflector
1026	1	1	1	288926251	Pulley K
1032	2	2	2	51100306A	B.H.M. Screw, 3 x 6
1033	2	2	2	54050300R	T.L. Washer OR
1103	1	1	1	288627102	Holder
1104	2	2	2	51570306B	P.H. Tapped Screw, 3 x 6
1107	2	2	2	51480306A	B.H.M. Screw F, 3 x 6
1111	2	2	2	51570306B	P.H. Tapped Screw, 3 x 6
1112	2	2	2	54050300R	T.L. Washer OR
1115	2	2	2	288610701	Sheet
1303	1	1	1	285310650	Bearing K
1308	1	1	1	51640410D	Set Screw C.P. 4 x 10
1309	1	1	1	54040402N	Spring Washer
1310	1	1	1	53110403E	Hexagon Nut
1403	1	1	1	257710602	Bearing
1404	1	1	1	141511801	Spacer
1405	2	2	2	51040306A	F.H.M. Screw, 3 x 6
1410	1	1	1	285011202	Shaft
1411	1	1	1	54040402N	Spring Washer
1603	1	1	1	291630201	Dial
1606	1	1	1	285610701	Sheet
1608	1	1	1	285326901	Protector
1609	2	2	2	51570306B	P.H. Tapped Screw, 3 x 6
1612	1	1	1	291526901	Protector
1613	2	2	2	51570305B	P.H. Tapped Screw, 3 x 5
1615	2	2	2	287105302	Cover
1618	1	1	1	291626901	Protector
1619	2	2	2	51100305S	B.H.M. Screw, 3 x 5
1622	1	1	1	288612201	Sticker
1624	1	1	1	281912005	Insulator
1703	1	1	1	273010950	Shield K
1706	1	1	1	291612003	Insulator
1707	1	1	1	288910903	Shield
1708	2	2	2	51100306S	B.H.M. Screw, 3 x 6
1709	6	6	6	291612002	Insulator
1711	2	2	2	281916008	Bracket
1712	4	4	4	51100306A	B.H.M. Screw, 3 x 6
1713	4	4	4	51570306B	P.H. Tapped Screw 3 x 5
1715	2	2	2	288912006	Insulator
1716	1	1	1	54020301E	Flat Washer
1720	3	3	3	273010903	Shield
1722	1	1	1	341105605	Buffer
1725	5	5	5	51100306S	B.H.M. Screw, 3 x 6
1728	1	1	1	138200503	Clamper

REF. DESIG.	QTY.			PART NO.	DESCRIPTION
	U	C	E		
2003	2	2	2	292826701	Heat Sink
2005	4	4	4	282016007	Bracket
2006	16	16	16	51380306T	P.H. Tapped Screw, 3 x 6
2008	8	8	8	51570306B	P.H. Tapped Screw, 3 x 6
2010	8	8	8	281810104	Support
2011	8	8	8	51100306S	B.H.M. Screw, 3 x 6
2015	8	8	8	51100312E	B.H.M. Screw, 3 x 12
2018	2	2	2	282026702	Heat Sink
2019	2	2	2	51060308S	P.H.M. Screw, 3 x 8
2024	2	2	2	281811806	Spacer
2028	4	4	4	291626701	Heat Sink
2029	2	2	2	112600501	Clamper
2031	4	4	4	51100310E	B.H.M. Screw, 3 x 10
2032	4	4	4	53110301E	Hexagon Nut
2034	1	1	1	291610903	Shield
2035	3	3	3	51570306B	P.H. Tapped Screw, 3 x 6
2103	1	1	1	291626702	Heat Sink
2104	2	2	2	51102606S	B.H.M. Screw, 6 x 6
2105	1	1	1	51100310E	B.H.M. Screw, 3 x 10
2106	1	1	1	53110301E	Hexagon Nut
2107	1	1	1	51570306S	P.H. Tapped Screw, 3 x 6
2108	1	1	1	54050300R	T.L. Washer OR
2109	3	3	3	51100306S	B.H.M. Screw, 3 x 6
2114	4	4	4	51570306B	P.H. Tapped Screw, 3 x 6
2115	1	1	1	291616006	Bracket
2116	1	1	1	51570408B	P.H. Tapped Screw, 4 x 8
2117	1	1	1	54050400R	T.L. Washer OR
2118	1	1	1	292826702	Heat Sink
2119	2	2	2	51570306B	P.H. Tapped Screw, 3 x 6
2120	1	1	1	51100314E	B.H.M. Screw, 3 x 14
2121	1	1	1	54040302N	Spring Washer
2122	1	1	1	292812001	Insulator
2123	1	1	1	287100501	Clamper
2128	4	4	4	51490514A	B.H.M. Screw FS, 5 x 14
2129	4	4	4	53110501A	Hexagon Nut
2130	4	4	4	54040602N	Spring Washer
2131	2	2	2	291616007	Bracket
2203	1	1	1	292810901	Shield
2204	4	4	4	285610102	Support
2205	1	1	1	281810107	Support
2206	3	3	3	51060304E	P.H.M. Screw, 3 x 4
2207	2	2	2	50020305B	P.H. Screw, 3 x 5
2208	2	2	2	59030805P	Washer
2213	2	2	2	51100306S	B.H.M. Screw, 3 x 6
2214	1	1	1	62030039W	Lug
2215	2	2	2	292810101	Support
2216	2	2	2	54020301E	Flat Washer
2217	1	1	1	291612005	Insulator
2223	2	2	2	288616011	Bracket
2224	2	2	2	288612009	Insulator
2225	4	4	4	51570306B	P.H. Tapped Screw, 3 x 6
2303	4	4	4	288810102	Support
2305	1	1	1	291610902	Shield
2306	4	4	4	51100304S	B.H.M. Screw, 3 x 4
2313	2	2	2	288810102	Support
2314	2	2	2	51100306S	B.H.M. Screw, 3 x 6
2316	1	1	1	291610901	Shield
2317	2	2	2	51100304S	B.H.M. Screw, 3 x 4
2323	2	2	2	291610101	Support
2324	2	2	2	51100304S	B.H.M. Screw, 3 x 4

U: For U.S.A.
C: For Canada
E: For Europe

REF. DESIG.	QTY.			PART NO.	DESCRIPTION
	U	C	E		
2403			1	289016008	Bracket
2404			1	285412001	Insulator
2405			4	51100310A	B.H.M. Screw, 3 x 10
2406			5	54060300R	T.L. Washer Ir
2415			1	285416003	Bracket
2416			2	51570305B	P.H. Tapped Screw, 3 x 5
2417			2	51100306S	B.H.M. Screw, 3 x 6
2418			1	291712002	Insulator
2425	1	1	1	138200503	Clamper
2428	1	1	1	51570306B	P.H. Tapped Screw, 3 x 6
2429	1	1	1	54050300R	T.L. Washer OR
2432	1	1	1	62030039W	Lug
2503	1	1	1	291710550	Chassis K
2513	5	5	5	288600502	Clamper
2514	5	5	5	288600504	Clamper
2521	2	2	2	292810102	Support
2522	2	2	2	54040402N	Spring Washer
2530	2	2	2	288925901	Bush
2532	1	1	1	281805603	Buffer
2605	2	2	2	62030039W	Lug
2607	3	3	3	51570306B	P.H. Tapped Screw, 3 x 6
2610	1	1	1	62030039W	Lug
2611	1	1	1	51570306B	P.H. Tapped Screw, 3 x 6
2614	1	1	1	62030039W	Lug
2615	1	1	1	51570306B	P.H. Tapped Screw, 3 x 6
2620	1	1	1	62030039W	Lug
2705	2	2	2	138200503	Clamper
2706	2	2	2	51570305B	P.H. Tapped Screw, 3 x 5
2709	1	1	1	121000501	Clamper
2710	1	1	1	51570306B	P.H. Tapped Screw, 3 x 6
2712	2	2	2	121000501	Clamper
2716	1	1	1	121000501	Clamper
2719	1	1	1	138200503	Clamper
2802	1			292885101	Instructions, Set
2806		1	1	292885131	Instructions, Set
2807		1		288685110	Instructions, Leaflet
2809	1			292885601	Schematic
2810			1	292885602	Schematic
2811		1		292885603	Schematic
2814	1	1	1	281885108	Instructions, Accessories
2815		1		287185104	Instructions, Accessories
2817	1	1	1	281885104	Instruction, Packing
2824	1	1	1	257785401	Guarantee Card
2825	1	1	1	257785102	Instructions, Red Tag
2826		1		257781301	Envelope
2827			1	291881301	Envelope
2831			1	281881301	Envelope
2902	1	1	1	292880101	Packing Case, Inner
2903	1	1	1	292880111	Packing Case, Outer
2908	1	1	1	288680302	Cushion, Upper
2909	1	1	1	288680303	Cushion, Lower
2912	1	1	1	901483838	Polyethylene Bag, Set
2914	1	1	1	901302501	Polyethylene Bag, Printed Matter
2915	1	1	1	901302501	Polyethylene Bag, Accessories
2916	1	1	1	291810701	Sheet
2917	1	1	1	102980401	Sleeve, Power Cord
2918			1	956000004	Hang Tag
2919	1	1	1	273182101	Silicagel
2920	1	1	1	281905601	Buffer, AM Antenna
2922		4		952281501	Serial No Card

REF. DESIG.	QTY.			PART NO.	DESCRIPTION
	U	C	E		
2923			4	952301512	Serial No Card
2924			4	952301511	Serial No Card
2931	1	1	1	ZA0200007	Ext Antenna
8536	1	1	1	62030039W	Lug
9636	1	1	1	62030039W	Lug
P100	1	1	1	YD2819002	P.W. Board
	1	1	1	ZZ2928102	P.W. Board Assembly
R101	1	1	1	RT0556314	Resistor, 56KΩ ±5% ¼W
R102	1	1	1	RT0510514	Resistor, 1MΩ ±5% ¼W
R103	1	1	1	RT0510414	Resistor, 100KΩ ±5% ¼W
R104	1	1	1	RT0522114	Resistor, 220Ω ±5% ¼W
R105	1	1	1	RT0522114	Resistor, 220Ω ±5% ¼W
R106	1	1	1	RT0510214	Resistor, 1KΩ ±5% ¼W
R107	1	1	1	RT0547214	Resistor, 4.7KΩ ±5% ¼W
R108	1	1	1	RT0522314	Resistor, 22KΩ ±5% ¼W
R109	1	1	1	RT0522314	Resistor, 22KΩ ±5% ¼W
R110	1	1	1	RT0512214	Resistor, 1.2KΩ ±5% ¼W
R111	1	1	1	RT0510114	Resistor, 100Ω ±5% ¼W
R112	1	1	1	RT0510114	Resistor, 100Ω ±5% ¼W
R113	1	1	1	RT0510114	Resistor, 100Ω ±5% ¼W
R114	1	1	1	RT0522314	Resistor, 22KΩ ±5% ¼W
R115	1	1	1	RT0510114	Resistor, 100Ω ±5% ¼W
C101	1	1	1	CA4330001	Variable Cap
C102	1	1	1	CT1100001	Trimming Cap, 1.5~10PF
C103	1	1	1	CT1100002	Trimming Cap, 1.5~10PF
C104	1	1	1	CT1100001	Trimming Cap, 1.5~10PF
C105	1	1	1	CT1100001	Trimming Cap, 1.5~10PF
C106	1	1	1	CT1100001	Trimming Cap, 1.5~10PF
C107	1	1	1	DD1615001	Ceramic Cap, 15PF ±10%
C108	1	1	1	DK1710201	Ceramic Cap, 1000PF ±20%
C109	1	1	1	DD1105001	Ceramic Cap, 5PF ±0.5PF
C110	1	1	1	DK1710201	Ceramic Cap, 1000PF ±20%
C111	1	1	1	DD1615001	Ceramic Cap, 15PF ±10%
C112	1	1	1	DK1710201	Ceramic Cap, 1000PF ±20%
C113	1	1	1	DK1710301	Ceramic Cap, 0.01μF ±20%
C114	1	1	1	DD1001001	Ceramic Cap, 1.0PF ±0.25
C115	1	1	1	DD1615001	Ceramic Cap, 15PF ±10%
C116	1	1	1	DK1710301	Ceramic Cap, 0.01μF ±20%
C117	1	1	1	DK1710301	Ceramic Cap, 0.01μF ±20%
C118	1	1	1	DD1620003	Ceramic Cap, 20PF ±10%
C119	1	1	1	DD1210006	Ceramic Cap, 10PF ±1PF
C120	1	1	1	DD1615003	Ceramic Cap, 15PF ±10%
C121	1	1	1	DD1615003	Ceramic Cap, 15PF ±10%
C122	1	1	1	DK1710301	Ceramic Cap, 0.01μF ±20%
C123	1	1	1	DK1710301	Ceramic Cap, 0.01μF ±20%
C124	1	1	1	DK1710301	Ceramic Cap, 0.01μF ±20%
C127	1	1	1	DK1710301	Ceramic Cap, 0.01μF ±20%
C128	1	1	1	DK1710301	Ceramic Cap, 0.01μF ±20%
C107	1	1	1	DD1625001	Ceramic Cap, 25PF ±10%
C111	1	1	1	DD1625001	Ceramic Cap, 25PF ±10%
C115	1	1	1	DD1625001	Ceramic Cap, 25PF ±10%
C118	1	1	1	DD1615005	Ceramic Cap, 15PF ±10%
L101	1	1	1	LA1202603	Ant. Coil
L101	1	1	1	LA1203601	Ant. Coil
L102	1	1	1	LA1202604	RF Coil
L102	1	1	1	LA1202608	RF Coil
L103	1	1	1	LA1202605	RF Coil
L103	1	1	1	LA1202609	RF Coil

U: For U.S.A.
 C: For Canada
 E: For Europe

REF. DESIG.	QTY.			PART NO.	DESCRIPTION
	U	C	E		
L104	1	1	1	L01201608	OSC., Coil
L105	1	1	1	LI1001601	IFT
H101	1	1	1	HF200191A	FET, 2SK19 (Y)
H102	1	1	1	HF200191A	FET, 2SK19 (Y)
H103	1	1	1	HT305351B	Transistor, 2SC535 (B)
J101	1	1	1	YP1000094	Plug
J102	1	1	1	YP1000094	Plug
J103	1	1	1	57271240W	Lug Eyelet
J104	1	1	1	57271240W	Lug Eyelet
J105	1	1	1	57271240W	Lug Eyelet
J106	1	1	1	57271240W	Lug Eyelet
J107	1	1	1	57271240W	Lug Eyelet
J108	1	1	1	57271240W	Lug Eyelet
J109	1	1	1	57271240W	Lug Eyelet
P150 AM TUNER BOARD					
P150	1	1	1	YD2909001	P.W. Board,
	1	1	1	ZZ2928101	P.W. Board Assembly
R151	1	1	1	RT0510314	Resistor, 10KΩ ±5% ¼W
R152	1	1	1	RT0530314	Resistor, 30KΩ ±5% ¼W
R153	1	1	1	RT0582314	Resistor, 82KΩ ±5% ¼W
R154	1	1	1	RT0522314	Resistor, 22KΩ ±5% ¼W
R156	1	1	1	RT0510414	Resistor, 100KΩ ±5% ¼W
R157	1	1	1	RC0000012	Resistor, 0Ω ½W
R158	1	1	1	RT0539314	Resistor, 39KΩ ±5% ¼W
R159	1	1	1	RT0539214	Resistor, 3.9KΩ ±5% ¼W
R160	1	1	1	RC0000012	Resistor, 0Ω
R161	1	1	1	RT0543214	Resistor, 4.3KΩ ±5% ¼W
R162	1	1	1	RT0510114	Resistor, 100Ω ±5% ¼W
R163	1	1	1	RT0515214	Resistor, 1.5KΩ ±5% ¼W
R164	1	1	1	RT0533114	Resistor, 330Ω ±5% ¼W
R165	1	1	1	RC0000012	Resistor, 0Ω ½W
R166	1	1	1	RC0000012	Resistor, 0Ω ½W
R167	1	1	1	RT0522214	Resistor, 2.2KΩ ±5% ¼W
R168	1	1	1	RT0582314	Resistor, 82KΩ ±5% ¼W
R169	1	1	1	RT0562414	Resistor, 620KΩ ±5% ¼W
R170	1	1	1	RT0551114	Resistor, 510Ω ±5% ¼W
R171	1	1	1	RT0522214	Resistor, 2.2KΩ ±5% ¼W
R172	1	1	1	RT0556214	Resistor, 5.6KΩ ±5% ¼W
R173	1	1	1	RT0510214	Resistor, 1KΩ ±5% ¼W
R174	1	1	1	RT0510114	Resistor, 100Ω ±5% ¼W
R175	1	1	1	RT0510414	Resistor, 100KΩ ±5% ¼W
R176	1	1	1	RT0510314	Resistor, 10KΩ ±5% ¼W
R177	1	1	1	RT0512314	Resistor, 12KΩ ±5% ¼W
R178	1	1	1	RA0103025	Trimming Resistor 10KΩ B
R179	1	1	1	RT0510314	Resistor, 10KΩ ±5% ¼W
R180	1	1	1	RT0515214	Resistor, 1.5KΩ ±5% ¼W
R181	1	1	1	RT0510114	Resistor, 100Ω ±5% ¼W
R182	1	1	1	RT0515214	Resistor, 1.5KΩ ±5% ¼W
C151	1	1	1	DK1710301	Ceramic Cap, 0.1μF ±20%
C152	1	1	1	DF1747305	Film Cap, 0.47μF ±20%
C154	1	1	1	DK1710301	Film Cap, 0.1μF ±20%
C155	1	1	1	DF6545101	Film Cap, 450PF ±5%
C156	1	1	1	DD1615001	Ceramic Cap, 15PF ±10%
C157	1	1	1	DK1710301	Ceramic Cap, 0.01μF ±20%
C158	1	1	1	DK1840302	Ceramic Cap, 0.04μF ±20%
C159	1	1	1	DK1840302	Ceramic Cap, 0.04μF ±20%
C160	1	1	1	DK1710301	Ceramic Cap, 0.01μF ±20%
C161	1	1	1	DK1710301	Ceramic Cap, 0.01μF ±20%

REF. DESIG.	QTY.			PART NO.	DESCRIPTION
	U	C	E		
C162	1	1	1	DK1710301	Ceramic Cap, 0.01μF ±20%
C163	1	1	1	DF1615305	Film Cap, 0.015μF ±10%
C164	1	1	1	DF1627305	Film Cap, 0.027μF ±10%
C165	1	1	1	DF1756205	Film Cap, 5600PF ±20%
C166	1	1	1	DK1840302	Film Cap, 0.04μF ±20%
C167	1	1	1	EA2260169	Electrolytic Cap, 22μF 16V
C168	1	1	1	EA1070169	Electrolytic Cap, 100μF 16V
C169	1	1	1	EA4750359	Electrolytic Cap, 4.7μF 35V
C170	1	1	1	EA1070169	Electrolytic Cap, 100μF 16V
C171	1	1	1	EA1050509	Electrolytic Cap, 1μF 50V
C172	1	1	1	EA1070169	Electrolytic Cap, 100μF 16V
C173	1	1	1	EA4750359	Electrolytic Cap, 4.7μF 35V
H151	1	1	1	HC1000506	I.C. μPC30C
H152	1	1	1	HT313272A	Transistor, 2SC1327 S.T.
H153	1	1	1	HT104942A	Transistor, 2SA494 Y.G.
H154	1	1	1	HT104942A	Transistor, 2SA494 Y.G.
H155	1	1	1	HH0000212	Thermistor, 31D27
L151	1	1	1	LA1001019	RF Coil, AM
L152	1	1	1	LO1001050	OSC. Coil, AM
L153	1	1	1	LI1028003	I.F.T., AM Ceramic Filter
L154	1	1	1	LC1332002	Choke Coil, 3.3μH
L155	1	1	1	LC1332002	Choke Coil, 3.3μH
J151	1	1	1	YP1000113	Plug
J152	1	1	1	YP1000113	Plug
J153	1	1	1	YP1000113	Plug
J155	1	1	1	YP1000113	Plug
J156	1	1	1	YP1000113	Plug
J157	1	1	1	YP1000113	Plug
J158	1	1	1	YP1000113	Plug
J160	1	1	1	YP1000113	Plug
J161	1	1	1	YP1000113	Plug
P200 FM IF BOARD					
P200	1	1	1	YD2884006	P.W. Board
	1	1	1	ZZ2928106	P.W. Board Assembly
R201	1	1	1	RT0533014	Resistor, 33Ω ±10% ¼W
R202	1	1	1	RT0510114	Resistor, 100Ω ±10% ¼W
R203	1	1	1	RT0512314	Resistor, 12KΩ ±10% ¼W
R204	1	1	1	RT0547214	Resistor, 4.7KΩ ±10% ¼W
R205	1	1	1	RT0510214	Resistor, 1KΩ ±10% ¼W
R206	1	1	1	RT0522214	Resistor, 2.2KΩ ±10% ¼W
R207	1	1	1	RT0510314	Resistor, 10KΩ ±10% ¼W
R208	1	1	1	RT0533314	Resistor, 33KΩ ±10% ¼W
R210	1	1	1	RT0533014	Resistor, 33Ω ±10% ¼W
R211	1	1	1	RT0515214	Resistor, 1.5KΩ ±10% ¼W
R212	1	1	1	RT0533214	Resistor, 3.3KΩ ±10% ¼W
R213	1	1	1	RT0547114	Resistor, 470Ω ±10% ¼W
R214	1	1	1	RT0510214	Resistor, 1KΩ ±10% ¼W
R215	1	1	1	RT0510114	Resistor, 100Ω ±10% ¼W
R216	1	1	1	RT0515214	Resistor, 1.5KΩ ±10% ¼W
R217	1	1	1	RT0533214	Resistor, 3.3KΩ ±10% ¼W
R218	1	1	1	RT0515114	Resistor, 150Ω ±10% ¼W
R219	1	1	1	RT0510214	Resistor, 1KΩ ±10% ¼W
R220	1	1	1	RT0510214	Resistor, 1KΩ ±10% ¼W
R221	1	1	1	RT0518314	Resistor, 18KΩ ±10% ¼W
R222	1	1	1	RT0510414	Resistor, 100KΩ ±10% ¼W
R223	1	1	1	RT0575014	Resistor, 75Ω ±10% ¼W
R224	1	1	1	RT0527114	Resistor, 270Ω ±10% ¼W
R225	1	1	1	RT0515114	Resistor, 150Ω ±10% ¼W
R226	1	1	1	RT0515214	Resistor, 1.5KΩ ±10% ¼W
R227	1	1	1	RT0533214	Resistor, 3.3KΩ ±10% ¼W

REF. DESIG.	QTY.			PART NO.	DESCRIPTION
	U	C	E		
R228	1	1	1	RT0515114	Resistor, 150Ω ±10% ¼W
R229	1	1	1	RT0510214	Resistor, 1KΩ ±10% ¼W
R230	1	1	1	RT0510214	Resistor, 1KΩ ±10% ¼W
R231	1	1	1	RT0515114	Resistor, 150Ω ±10% ¼W
R232	1	1	1	RT0510414	Resistor, 100KΩ ±10% ¼W
R233	1	1	1	RT0527314	Resistor, 27KΩ ±10% ¼W
R234	1	1	1	RT0522314	Resistor, 22KΩ ±5% ¼W
R235	1	1	1	RT0510114	Resistor, 100Ω ±5% ¼W
R236	1	1	1	RT0513114	Resistor, 130Ω ±5% ¼W
R237	1	1	1	RT0582214	Resistor, 87KΩ ±5% ¼W
R238	1	1	1	RT0515314	Resistor, 15KΩ ±5% ¼W
R239	1	1	1	RT0515114	Resistor, 150Ω ±5% ¼W
R240	1	1	1	RT0510214	Resistor, 1KΩ ±5% ¼W
R241	1	1	1	RT0510214	Resistor, 1KΩ ±5% ¼W
R242	1	1	1	RT0568314	Resistor, 68KΩ ±5% ¼W
R243	1	1	1	RT0510114	Resistor, 100Ω ±5% ¼W
R244	1	1	1	RT0510414	Resistor, 100KΩ ±5% ¼W
R245	1	1	1	RT0527114	Resistor, 270Ω ±5% ¼W
R246	1	1	1	RT0582214	Resistor, 8.2KΩ ±5% ¼W
R247	1	1	1	RT0515314	Resistor, 15KΩ ±5% ¼W
R248	1	1	1	RT0515114	Resistor, 150Ω ±5% ¼W
R249	1	1	1	RT0510214	Resistor, 1KΩ ±5% ¼W
R250	1	1	1	RT0510214	Resistor, 1KΩ ±5% ¼W
R252	1	1	1	RT0510414	Resistor, 100KΩ ±5% ¼W
R253	1	1	1	RT0515114	Resistor, 150Ω ±5% ¼W
R254	1	1	1	RT0515314	Resistor, 15KΩ ±5% ¼W
R256	1	1	1	RT0512314	Resistor, 12KΩ ±5% ¼W
R257	1	1	1	RT0582214	Resistor, 8.2KΩ ±5% ¼W
R258	1	1	1	RT0515314	Resistor, 15KΩ ±5% ¼W
R259	1	1	1	RT0515114	Resistor, 150Ω ±5% ¼W
R260	1	1	1	RT0510214	Resistor, 1KΩ ±5% ¼W
R261	1	1	1	RT0522314	Resistor, 22KΩ ±5% ¼W
R262	1	1	1	RT0522314	Resistor, 22KΩ ±5% ¼W
R263	1	1	1	RT0522114	Resistor, 220Ω ±5% ¼W
R264	1	1	1	RT0582114	Resistor, 820Ω ±5% ¼W
R265	1	1	1	RT0582114	Resistor, 820Ω ±5% ¼W
R266	1	1	1	RT0510314	Resistor, 10KΩ ±5% ¼W
R267	1	1	1	RT0510314	Resistor, 10KΩ ±5% ¼W
R268	1	1	1	RT0510114	Resistor, 100Ω ±5% ¼W
R269	1	1	1	RT0527314	Resistor, 27KΩ ±5% ¼W
R270	1	1	1	RT0510114	Resistor, 100Ω ±5% ¼W
R271	1	1	1	RT0510114	Resistor, 100Ω ±5% ¼W
R272	1	1	1	RT0556214	Resistor, 5.6KΩ ±5% ¼W
R273	1	1	1	RT0510414	Resistor, 100KΩ ±5% ¼W
R274	1	1	1	RT0518414	Resistor, 180KΩ ±5% ¼W
R275	1	1	1	RT0510414	Resistor, 100KΩ ±5% ¼W
R276	1	1	1	RT0522214	Resistor, 2.2KΩ ±5% ¼W
R277	1	1	1	RT0510114	Resistor, 100Ω ±5% ¼W
C201	1	1	1	DK1820302	Ceramic Cap, 0.02μF ±80% -20%
C202	1	1	1	DK1820302	Ceramic Cap, 0.02μF ±80% -20%
C203	1	1	1	DK1840302	Ceramic Cap, 0.04μF ±80% -20%
C204	1	1	1	DK1820302	Ceramic Cap, 0.02μF ±80% -20%
C205	1	1	1	DD1620101	Ceramic Cap, 200PF ±10%
C206	1	1	1	DK1820302	Ceramic Cap, 0.02μF ±80% -20%
C207	1	1	1	DK1820302	Ceramic Cap, 0.02μF ±80% -20%
C208	1	1	1	DK1810402	Ceramic Cap, 0.1μF ±80% -20%
C209	1	1	1	DK1820302	Ceramic Cap, 0.02μF ±80% -20%
C210	1	1	1	DK1840302	Ceramic Cap, 0.04μF ±80% -20%
C211	1	1	1	DK1840302	Ceramic Cap, 0.04μF ±80% -20%
C212	1	1	1	DK1840302	Ceramic Cap, 0.04μF ±80% -20%
C213	1	1	1	DK1820302	Ceramic Cap, 0.02μF ±80% -20%

REF. DESIG.	QTY.			PART NO.	DESCRIPTION
	U	C	E		
C214	1	1	1	DD1620101	Ceramic Cap, 200PF ±10%
C215	1	1	1	DK1820302	Ceramic Cap, 0.02μF ±80% -20%
C216	1	1	1	DK1820302	Ceramic Cap, 0.02μF ±80% -20%
C217	1	1	1	DK1840302	Ceramic Cap, 0.04μF ±80% -20%
C218	1	1	1	DK1820302	Ceramic Cap, 0.02μF ±80% -20%
C219	1	1	1	DD1620101	Ceramic Cap, 200PF ±10%
C220	1	1	1	DK1820302	Ceramic Cap, 0.02μF ±80% -20%
C221	1	1	1	DK1820302	Ceramic Cap, 0.02μF ±80% -20%
C222	1	1	1	DK1840302	Ceramic Cap, 0.04μF ±80% -20%
C223	1	1	1	DK1820302	Ceramic Cap, 0.02μF ±80% -20%
C224	1	1	1	DK1820302	Ceramic Cap, 0.02μF ±80% -20%
C225	1	1	1	DD1620101	Ceramic Cap, 200PF ±10%
C226	1	1	1	DK1820302	Ceramic Cap, 0.02μF ±80% -20%
C227	1	1	1	DK1820302	Ceramic Cap, 0.02μF ±80% -20%
C228	1	1	1	DK1840301	Ceramic Cap, 0.04μF ±80% -20%
C229	1	1	1	DK1820302	Ceramic Cap, 0.02μF ±80% -20%
C230	1	1	1	DK1820302	Ceramic Cap, 0.02μF ±80% -20%
C231	1	1	1	DK1710201	Ceramic Cap, 0.001μF ±80% -20%
C232	1	1	1	DK1810402	Ceramic Cap, 0.1μF ±80% -20%
C233	1	1	1	DK1820302	Ceramic Cap, 0.02μF ±80% -20%
C234	1	1	1	DK1820302	Ceramic Cap, 0.02μF ±80% -20%
C235	1	1	1	DK1840302	Ceramic Cap, 0.04μF ±80% -20%
C236	1	1	1	DK1820302	Ceramic Cap, 0.02μF ±80% -20%
C237	1	1	1	EA1060169	Electrolytic Cap, 10μF 16V
C238	1	1	1	DD1620101	Ceramic Cap, 200PF ±20%
C239	1	1	1	DD1620101	Ceramic Cap, 200PF ±20%
C240	1	1	1	EA1070109	Electrolytic Cap, 100μF 10V
C242	1	1	1	EA1070169	Electrolytic Cap, 100μF 16V
C243	1	1	1	DK1840302	Ceramic Cap, 0.04μF ±80% -20%
C244	1	1	1	EA1060169	Electrolytic Cap, 10μF 16V
C245	1	1	1	EA2260169	Electrolytic Cap, 22μF 16V
C246	1	1	1	EA1060169	Electrolytic Cap, 22μF 16V
C247	1	1	1	DK1820302	Ceramic Cap, 0.02μF ±80% -20%
C248	1	1	1	DD1540001	Ceramic Cap, 40PF ±5%
C249	1	1	1	DK1840302	Ceramic Cap, 0.04μF ±80% -20%
C262	1	1	1	DD1620101	Ceramic Cap, 200PF ±20%
F201	1	1	1	FF1107005	Ceramic Filter
F202	1	1	1	FF1107005	Ceramic Filter
F203	1	1	1	FF1107005	Ceramic Filter
H201	1	1	1	HT308291C	Transistor, 2SC829C
H202	1	1	1	HT308291C	Transistor, 2SC829C
H203	1	1	1	HT308291C	Transistor, 2SC829C
H204	1	1	1	HT308291C	Transistor, 2SC829C
H205	1	1	1	HT308291C	Transistor, 2SC829C
H206	1	1	1	HT308291C	Transistor, 2SC829C
H207	1	1	1	HT308291C	Transistor, 2SC829C
H208	1	1	1	HT306441B	Transistor, 2SC644S
H210	1	1	1	HD1000105	Diode, 1N60
H211	1	1	1	HD1000105	Diode, 1N60
H212	1	1	1	HD1000105	Diode, 1N60
H213	1	1	1	HD1000105	Diode, 1N60
H214	1	1	1	HD1000105	Diode, 1N60
H215	1	1	1	HD1000105	Diode, 1N60
H216	1	1	1	HD2001105	Diode, 1S1555
H217	1	1	1	HD2001105	Diode, 1S1555
H218	1	1	1	HD1000105	Diode, 1N60
H219	1	1	1	HD1000105	Diode, 1N60
H220	1	1	1	HD2001105	Diode, 1S1555
H221	1	1	1	HD2001105	Diode, 1S1555
H222	1	1	2	HD1000105	Diode, 1N60
H223	1	1	1	HD1000105	Diode, 1N60

U: For U.S.A.
C: For Canada
E: For Europe

REF. DESIG.	QTY.			PART NO.	DESCRIPTION
	U	C	E		
H224	1	1	1	HD2001105	Diode, 1S1555
H225	1	1	1	HD2001105	Diode, 1S1555
H226	1	1	1	HD1000105	Diode, 1N60
H227	1	1	1	HD1000105	Diode, 1N60
H228	1	1	1	HD2001105	Diode, 1S1555
H229	1	1	1	HD2001105	Diode, 1S1555
H230	1	1	1	HD1000302	Diode, 20A90M
H231	1	1	1	HD1000302	Diode, 20A90M
H232	1	1	1	HD1000302	Diode, 20A90M
L201	1	1	1	L11401623	IFT, FM
L202	1	1	1	LC1332002	Choke Coil, 3.3μM
J201	}	1	1	YP1000120	Plug
J208					
J210					
J212					
J212	}	1	1	YP1000120	Plug
J212					
J212					
J212					
P300	1	1	1	YD2890003	P.W. Board
	1	1	1	ZZ2928103	P.W. Board Assembly
R301	1	1	1	RA0202011	Trimming Resistor, 2KΩ B
R302	1	1	1	RT0522414	Resistor, 220KΩ ±5% ¼W
R303	1	1	1	RT0556314	Resistor, 56KΩ ±5% ¼W
R304	1	1	1	RT0568314	Resistor, 68KΩ ±5% ¼W
R305	1	1	1	RT0510114	Resistor, 100Ω ±5% ¼W
R306	1	1	1	RT0518414	Resistor, 180KΩ ±5% ¼W
R307	1	1	1	RT0522414	Resistor, 220KΩ ±5% ¼W
R308	1	1	1	RT0512414	Resistor, 120KΩ ±5% ¼W
R309	1	1	1	RT0510414	Resistor, 100KΩ ±5% ¼W
R310	1	1	1	RT0568214	Resistor, 6.8KΩ ±5% ¼W
R311	1	1	1	RA0502020	Trimming Resistor, 5KΩ B
R312	1	1	1	RT0516314	Resistor, 16KΩ ±5% ¼W
R313	1	1	1	RT0510214	Resistor, 1KΩ ±5% ¼W
R314	1	1	1	RT0520314	Resistor, 20KΩ ±5% ¼W
R315	1	1	1	RT0510214	Resistor, 1KΩ ±5% ¼W
R316	1	1	1	RT0510214	Resistor, 1KΩ ±5% ¼W
R317	1	1	1	RT0539214	Resistor, 3.9KΩ ±5% ¼W
R318	1	1	1	RT0539214	Resistor, 3.9KΩ ±5% ¼W
R319	1	1	1	RT0522414	Resistor, 220KΩ ±5% ¼W
R320	1	1	1	RT0522314	Resistor, 22KΩ ±5% ¼W
R321	1	1	1	RT0510114	Resistor, 100Ω ±5% ¼W
R322	1	1	1	RT0510014	Resistor, 10Ω ±5% ¼W
R323	1	1	1	RT0522414	Resistor, 220KΩ ±5% ¼W
R324	1	1	1	RT0522414	Resistor, 220KΩ ±5% ¼W
R325	1	1	1	RT0530314	Resistor, 30KΩ ±5% ¼W
R326	1	1	1	RT0530314	Resistor, 30KΩ ±5% ¼W
R327	1	1	1	RT0510414	Resistor, 100KΩ ±5% ¼W
R328	1	1	1	RT0510414	Resistor, 100KΩ ±5% ¼W
R329	1	1	1	RT0515514	Resistor, 1.5MΩ ±5% ¼W
R330	1	1	1	RT0515514	Resistor, 1.5MΩ ±5% ¼W
R331	1	1	1	RT0551114	Resistor, 510Ω ±5% ¼W
R332	1	1	1	RT0551114	Resistor, 510Ω ±5% ¼W
R333	1	1	1	RT0522314	Resistor, 22KΩ ±5% ¼W
R334	1	1	1	RT0522314	Resistor, 22KΩ ±5% ¼W
R335	1	1	1	RT0510114	Resistor, 100Ω ±5% ¼W
R336	1	1	1	RT0510114	Resistor, 100Ω ±5% ¼W
R337	1	1	1	RT0582214	Resistor, 8.2KΩ ±5% ¼W
R338	1	1	1	RT0582214	Resistor, 8.2KΩ ±5% ¼W
R339	1	1	1	RT0547114	Resistor, 470Ω ±5% ¼W
R340	1	1	1	RT0547114	Resistor, 470Ω ±5% ¼W

REF. DESIG.	QTY.			PART NO.	DESCRIPTION
	U	C	E		
R341	1	1	1	RT0522414	Resistor, 220KΩ ±5% ¼W
R342	1	1	1	RT0522414	Resistor, 220KΩ ±5% ¼W
R343	1	1	1	RT0539214	Resistor, 3.9KΩ ±5% ¼W
R344	1	1	1	RT0556414	Resistor, 560KΩ ±5% ¼W
R345	1	1	1	RT0515314	Resistor, 15KΩ ±5% ¼W
R346	1	1	1	RT0512414	Resistor, 120KΩ ±5% ¼W
R347	1	1	1	RT0510114	Resistor, 100Ω ±5% ¼W
R348	1	1	1	RT0522414	Resistor, 220KΩ ±5% ¼W
R349	1	1	1	RT0556214	Resistor, 5.6KΩ ±5% ¼W
R350	1	1	1	RT0510314	Resistor, 10KΩ ±5% ¼W
R351	1	1	1	RT0510114	Resistor, 100Ω ±5% ¼W
R352	1	1	1	RT0533314	Resistor, 33KΩ ±5% ¼W
R353	1	1	1	RT0510114	Resistor, 100Ω ±5% ¼W
R354	1	1	1	RT0510414	Resistor, 100KΩ ±5% ¼W
R355	1	1	1	RT0527314	Resistor, 27KΩ ±5% ¼W
R356	1	1	1	RT0510414	Resistor, 100KΩ ±5% ¼W
R357	1	1	1	RT0510214	Resistor, 1KΩ ±5% ¼W
R358	1	1	1	RT0510114	Resistor, 100Ω ±5% ¼W
R359	1	1	1	RT0527314	Resistor, 27KΩ ±5% ¼W
R360	1	1	1	RT0533314	Resistor, 33KΩ ±5% ¼W
R361	1	1	1	RT0510414	Resistor, 100KΩ ±5% ¼W
R362	1	1	1	RA0104018	Trimming Resistor, 100KΩ B
R363	1	1	1	RA0103025	Trimming Resistor, 10KΩ B
R364	1	1	1	RT0522214	Resistor, 2.2KΩ ±5% ¼W
R365	1	1	1	RT0510114	Resistor, 100Ω ±5% ¼W
R366	1	1	1	RT0510314	Resistor, 10KΩ ±5% ¼W
R367	1	1	1	RT0510114	Resistor, 100Ω ±5% ¼W
R368	1	1	1	RT0527414	Resistor, 270KΩ ±5% ¼W
R369	1	1	1	RT0510314	Resistor, 10KΩ ±5% ¼W
R370	1	1	1	RT0512314	Resistor, 12KΩ ±5% ¼W
R371	1	1	1	RT0522114	Resistor, 220Ω ±5% ¼W
R373	1	1	1	RT0533314	Resistor, 33KΩ ±5% ¼W
R374	1	1	1	RA0103025	Trimming Resistor, 10KΩ B
R375	1	1	1	RT0510114	Resistor, 100Ω ±5% ¼W
R376	1	1	1	RT0510414	Resistor, 100KΩ ±5% ¼W
R377	1	1	1	RT0510414	Resistor, 100KΩ ±5% ¼W
R378	1	1	1	RT0556214	Resistor, 5.6KΩ ±5% ¼W
R379	1	1	1	RT0522214	Resistor, 2.2KΩ ±5% ¼W
R380	1	1	1	RT0527214	Resistor, 2.7KΩ ±5% ¼W
C301	1	1	1	DF1639205	Film Cap, 3900PF ±10%
C302	1	1	1	EA3360109	Electrolytic Cap, 33μF 10V
C303	1	1	1	DF1722305	Film Cap, 0.022μF ±20%
C304	1	1	1	EA2260169	Electrolytic Cap, 22μF 16V
C305	1	1	1	DF5547101	Film Cap, 470PF ±5%
C306	1	1	1	EA2260169	Electrolytic Cap, 22μF 16V
C307	1	1	1	EQ4740501	Electrolytic Cap, 0.47μF ±20% 50V
C308	1	1	1	EQ2240501	Electrolytic Cap, 0.22μF ±20% 50V
C309	1	1	1	EQ2240501	Electrolytic Cap, 0.22μF ±20% 50V
C310	1	1	1	DF1747301	Film Cap, 0.047μF ±20% 50V
C311	1	1	1	DF1515205	Film Cap, 1500PF ±5%
C312	1	1	1	DF1515205	Film Cap, 1500PF ±5%
C313	1	1	1	DD1536101	Ceramic Cap, 360PF ±5%
C314	1	1	1	DD1536101	Ceramic Cap, 360PF ±5%
C315	1	1	1	DF1533205	Film Cap, 3300PF ±5%
C316	1	1	1	DF1533205	Film Cap, 3300PF ±5%
C317	1	1	1	DF1515205	Film Cap, 1500PF ±5%
C318	1	1	1	DF1515205	Film Cap, 1500PF ±5%
C319	1	1	1	DF1522205	Film Cap, 2200PF ±5%
C320	1	1	1	DF1522205	Film Cap, 2200PF ±5%
C321	1	1	1	DF1510205	Film Cap, 1000PF ±5%
C322	1	1	1	DF1510205	Film Cap, 1000PF ±5%
C323	1	1	1	EV2240351	Electrolytic Cap, 0.22μF ±20% 35V

REF. DESIG.	QTY.			PART NO.	DESCRIPTION
	U	C	E		
C324	1	1	1	EV2240351	Electrolytic Cap, 0.22μF ±20% 35V
C325	1	1	1	EV1050352	Electrolytic Cap, 1μF ±20% 35V
C326	1	1	1	EV1050352	Electrolytic Cap, 1μF ±20% 35V
C327	1	1	1	EA2270259	Electrolytic Cap, 220μF 25V
C328	1	1	1	EA2270169	Electrolytic Cap, 220μF 16V
C329	1	1	1	EA1060169	Electrolytic Cap, 10μF 16V
C330	1	1	1	DK1840302	Ceramic Cap, 0.04μF ±80% ±20%
C331	1	1	1	EA1050509	Electrolytic Cap, 1μF 50V
C332	1	1	1	EA1060169	Electrolytic Cap, 10μF 16V
C333	1	1	1	DD1210001	Ceramic Cap, 10P ±10%
C334	1	1	1	DF1668301	Film Cap, 0.068μF ±10%
C335	1	1	1	DF1740301	Film Cap, 0.04μF ±20%
C336	1	1	1	DK1810402	Ceramic Cap, 0.1μF ±80% ±20%
C337	1	1	1	EA4750359	Electrolytic Cap, 4.7μF 35V
C338	1	1	1	EA1050509	Electrolytic Cap, 1μF 50V
C339	1	1	1	DK1840302	Ceramic Cap, 0.04μF ±80% ±20%
C340	1	1	1	DK1840302	Ceramic Cap, 0.04μF ±80% ±20%
C341	1	1	1	DK1840302	Ceramic Cap, 0.04μF ±80% ±20%
C343	1	1	1	DF1710402	Film Cap, 0.1μF ±80% ±20%
C344	1	1	1	DK1820302	Ceramic Cap, 0.02μF ±80% ±20%
H301	1	1	1	HF200301C	FET, 2SK30 (Y)
H302	1	1	1	HT308281D	Transistor, 2SC828S
H303	1	1	1	HT308281D	Transistor, 2SC828S
H304	1	1	1	HT307322A	Transistor, 2SC732 BorG
H305	1	1	1	HT307322A	Transistor, 2SC732 BorG
H306	1	1	1	HT104942A	Transistor, 2SA494 GorY
H307	1	1	1	HT104942A	Transistor, 2SA494 GorY
H308	1	1	1	HT308281D	Transistor, 2SC828S
H309	1	1	1	HT308281D	Transistor, 2SC828S
H310	1	1	1	HT308281D	Transistor, 2SC828S
H311	1	1	1	HT308281D	Transistor, 2SC828S
H312	1	1	1	HF200300A	FET
H313	1	1	1	HT308281D	Transistor, 2SC828S
H314	1	1	1	HT308281D	Transistor, 2SC828S
H315	1	1	1	HT308281D	Transistor, 2SC828S
H316	1	1	1	HT308281D	Transistor, 2SC828S
H317	1	1	1	HT308281D	Transistor, 2SC828S
H318	1	1	1	HD1000105	Diode, 1N60
H319	1	1	1	HD1000105	Diode, 1N60
H321	1	1	1	HC1000401	IC IC HA1156
L301	1	1	1	LS1029004	MPX Coil, 56mH
L302	1	1	1	LS1029004	MPX Coil, 56mH
L303	1	1	1	LS1029005	MPX Coil, 43mH
L304	1	1	1	LS1029005	MPX Coil, 43mH
L305	1	1	1	LS2105001	Choke Coil, 1mH
J322	1	1	1	YP1000113	Plug
J321	1	1	1	YP1000113	Plug
J301	1	1	1	YP1000113	Plug
J320	1	1	1	YP1000113	Plug
PU01	1	1	1	YD2916007	P.W. Board
	1	1	1	ZZ2928107	P.W. Board Assembly
PU04	1	1	1	RK0203032	Variable Resistor, 20K (B)
PU05	1	1	1	RK0503010	Variable Resistor, 50K (B)
LU01	1	1	1	LB3007526	Balun Coil
LU02	1	1	1	LC1154002	Choke Coil
JU01	1	1	1	YT0304014	Terminal
JU02	1	1	1	YP1000120	Plug

REF. DESIG.	QTY.			PART NO.	DESCRIPTION
	U	C	E		
JU03	1	1	1	YP1000120	Plug
JU04	1	1	1	YP1000113	Plug
JU07	1	1	1	YP1000113	Plug
P400	1	1	1	YD2892008	P400 PHONO AMP. BOARD P.W. Board, Phono Amp. 94HB
	1	1	1	ZZ2892008	P.W. Board Assembly
R401	1	1	1	RT0556314	Resistor, 56KΩ ¼W ±5%
R402	1	1	1	RT0556314	Resistor, 56KΩ ¼W ±5%
R403	1	1	1	RT0547114	Resistor, 470Ω ¼W ±5%
R404	1	1	1	RT0547114	Resistor, 470Ω ¼W ±5%
R405	1	1	1	RN0533314	Resistor, 33KΩ ¼W ±5%
R406	1	1	1	RN0510514	Resistor, 1MΩ ¼W ±5%
R407	1	1	1	RN0510514	Resistor, 1MΩ ¼W ±5%
R408	1	1	1	RA0104015	Trimming Resistor, 100KΩ B ±30%
R409	1	1	1	RA0104015	Trimming Resistor, 100KΩ B ±30%
R410	1	1	1	RN0527314	Resistor, 27KΩ ¼W ±5%
R411	1	1	1	RN0527314	Resistor, 27KΩ ¼W ±5%
R412	1	1	1	RT0562114	Resistor, 620Ω ¼W ±5%
R413	1	1	1	RT0562114	Resistor, 620Ω ¼W ±5%
R414	1	1	1	RT0522514	Resistor, 2.2MΩ ¼W ±5%
R415	1	1	1	RT0522514	Resistor, 2.2MΩ ¼W ±5%
R416	1	1	1	RN0522514	Resistor, 2.2MΩ ¼W ±5%
R417	1	1	1	RN0522514	Resistor, 2.2MΩ ¼W ±5%
R418	1	1	1	RN0527414	Resistor, 270KΩ ¼W ±5%
R419	1	1	1	RN0527414	Resistor, 270KΩ ¼W ±5%
R420	1	1	1	RT0547314	Resistor, 47KΩ ¼W ±5%
R421	1	1	1	RT0547314	Resistor, 47KΩ ¼W ±5%
R422	1	1	1	RT0522214	Resistor, 2.2KΩ ¼W ±5%
R423	1	1	1	RT0522214	Resistor, 2.2KΩ ¼W ±5%
R424	1	1	1	RN0568414	Resistor, 680KΩ ¼W ±5%
R425	1	1	1	RN0568414	Resistor, 680KΩ ¼W ±5%
R426	1	1	1	RN0510414	Resistor, 100KΩ ¼W ±5%
R427	1	1	1	RN0510414	Resistor, 100KΩ ¼W ±5%
R428	1	1	1	RN0547314	Resistor, 47KΩ ¼W ±5%
R429	1	1	1	RN0547314	Resistor, 47KΩ ¼W ±5%
R430	1	1	1	RT0547014	Resistor, 47Ω ¼W ±5%
R431	1	1	1	RT0547014	Resistor, 47Ω ¼W ±5%
R432	1	1	1	RN0533214	Resistor, 3.3KΩ ¼W ±5%
R433	1	1	1	RN0533214	Resistor, 3.3KΩ ¼W ±5%
R434	1	1	1	RT0510114	Resistor, 100Ω ¼W ±5%
R435	1	1	1	RT0547014	Resistor, 47Ω ¼W ±5%
R436	1	1	1	RT0547014	Resistor, 47Ω ¼W ±5%
C401	1	1	1	EV1050256	Electrolytic Cap, 1μF 25V ±20%
C402	1	1	1	EV1050256	Electrolytic Cap, 1μF 25V ±20%
C403	1	1	1	EE4760164	Electrolytic Cap, 47μF 16V ±20%
C404	1	1	1	EE4760164	Electrolytic Cap, 47μF 16V ±20%
C405	1	1	1	DD1540004	Ceramic Cap, 40PF 50V ±5% NPO
C406	1	1	1	DD1540004	Ceramic Cap, 40PF 50V ±5% NPO
C407	1	1	1	DD1104001	Ceramic Cap, 4PF 50V ±0.5PN750
C408	1	1	1	DD1104001	Ceramic Cap, 4PF 50V ±0.5PN750
C409	1	1	1	DF6556201	Film Cap, 5600PF 50V ±5%
C410	1	1	1	DF6556201	Film Cap, 5600PF 50V ±5%
C411	1	1	1	DF6516201	Film Cap, 1600PF 50V ±5%
C412	1	1	1	DF6516201	Film Cap, 1600PF 50V ±5%
C413	1	1	1	ED1070351	Electrolytic Cap, 100μF 35V
C414	1	1	1	DF1710552	Film Cap, 1μF 250V ±20%
C415	1	1	1	DF1710552	Film Cap, 1μF 250V ±20%
C416	1	1	1	DD1650001	Ceramic Cap, 50PF 250V ±20%
C417	1	1	1	DD1650001	Ceramic Cap, 50PF 250V ±20%

U: For U.S.A.
C: For Canada
E: For Europe

REF. DESIG.	QTY.			PART NO.	DESCRIPTION
	U	C	E		
H401	1	1	1	HT313441E	Transistor, 2SC1344 E
H402	1	1	1	HT313441E	Transistor, 2SC1344 E
H403	1	1	1	HT313442A	Transistor, 2SC1344 D, E
H404	1	1	1	HT313442A	Transistor, 2SC1344 D, E
H405	1	1	1	HT304580R	Transistor, 2SC458L B
H406	1	1	1	HT304580R	Transistor, 2SC458L B
H407	1	1	1	HD2000121	Varistor, 1S-2473C Ye
H408	1	1	1	HD2000121	Varistor, 1S-2473C Ye
H409	1	1	1	HV0000206	Varistor, VD1212
J401 }	1	1	1	YP1000113	Plug
J408					
PZ01 DIAL LAMP BOARD					
PZ01	1	1	1	YD2886016	P.W. Board
	1	1	1	ZZ2928116	P.W. Board Assembly
MZ01 }	1	1	1	IN1008007	Lamp
MZ05					
JZ01 }	1	1	1	YJ0800017	Socket
JZ10					
JZ11 }	1	1	1	YP1000113	Plug
JZ14					
PT01 MONITOR BOARD					
PT01	1	1	1	YD2916004	P.W. Board
	1	1	1	ZZ2916004	P.W. Board Assembly
	1	1	1	ZZ2916804	P.W. Board Assembly
RT01	1	1	1	RT0510214	Resistor, 1K Ω $\frac{1}{4}$ W $\pm 5\%$
RT02	1	1	1	RT0510214	Resistor, 1K Ω $\frac{1}{4}$ W $\pm 5\%$
CT01	1	1	1	DF1510205	Film Cap, 0.001 μ F 50V $\pm 5\%$
CT01	1	1	1	DF1522205	Film Cap, 0.002 μ F 50V $\pm 5\%$
CT02	1	1	1	DF1522205	Film Cap, 0.002 μ F 50V $\pm 5\%$
CT02	1	1	1	DF1510205	Film Cap, 0.001 μ F 50V $\pm 5\%$
ST01	1	1	1	SP0605007	Push Switch
JT01 }	1	1	1	YP1000113	Plug
JT23					
PY01 LAMP BOARD					
PY01	1	1	1	YD2916006	P.W. Board
	1	1	1	ZZ2916006	P.W. Board Assembly
MY01	1	1	1	IN1008037	Lamp, Dolby 8V 40mA
MY02	1	1	1	IN1008037	Lamp, AM 8V 40mA
MY03	1	1	1	IN1008037	Lamp, FM 8V 40mA
MY04	1	1	1	IN1008037	Lamp, Phono 8V 40mA
MY05	1	1	1	IN1008037	Lamp, AUX 8V 40mA
MY06	1	1	1	IN1008037	Lamp, Tape 1 8V 40mA
MY07	1	1	1	IN1008037	Lamp, Tape 2 8V 40mA
MY08	1	1	1	IN1012011	Lamp, Stereo 12V 40mA
JY01 }	1	1	1	YP1000113	Plug
JY11					
PE01 PRE TONE AMP. BOARD					
PE01	1	1	1	YD2917002	P.W. Board
	1	1	1	ZZ2928202	P.W. Board Assembly

REF DESIG.	QTY.			PART NO.	DESCRIPTION
	U	C	E		
RE02	1	1	1	RD0204001	Variable Resistor, 200K Ω (B)
RE03	1	1	1	RD0204001	Variable Resistor, 200K Ω (B)
RE04	1	1	1	RD0204001	Variable Resistor, 200K Ω (B)
RE09	1	1	1	RT0539114	Resistor, 390 Ω $\pm 5\%$ $\frac{1}{4}$ W
RE10	1	1	1	RT0539114	Resistor, 390 Ω $\pm 5\%$ $\frac{1}{4}$ W
RE11	1	1	1	RN0510514	Resistor, 1M Ω $\pm 5\%$ $\frac{1}{4}$ W
RE12	1	1	1	RN0510514	Resistor, 1M Ω $\pm 5\%$ $\frac{1}{4}$ W
RE13	1	1	1	RN0547414	Resistor, 470K Ω $\pm 5\%$ $\frac{1}{4}$ W
RE14	1	1	1	RN0547414	Resistor, 470K Ω $\pm 5\%$ $\frac{1}{4}$ W
RE15	1	1	1	RT0510214	Resistor, 1K Ω $\pm 5\%$ $\frac{1}{4}$ W
RE16	1	1	1	RT0510214	Resistor, 1K Ω $\pm 5\%$ $\frac{1}{4}$ W
RE17	1	1	1	RT0551214	Resistor, 5.1K Ω $\pm 5\%$ $\frac{1}{4}$ W
RE18	1	1	1	RT0551214	Resistor, 5.1K Ω $\pm 5\%$ $\frac{1}{4}$ W
RE19	1	1	1	RT0522414	Resistor, 220K Ω $\pm 5\%$ $\frac{1}{4}$ W
RE20	1	1	1	RT0522414	Resistor, 220K Ω $\pm 5\%$ $\frac{1}{4}$ W
RE21	1	1	1	RC0000012	Resistor, 0 Ω
RE22	1	1	1	RC0000012	Resistor, 0 Ω
RE23	1	1	1	RT0527314	Resistor, 27K Ω $\pm 5\%$ $\frac{1}{4}$ W
RE24	1	1	1	RT0527314	Resistor, 27K Ω $\pm 5\%$ $\frac{1}{4}$ W
RE25	1	1	1	RT0527314	Resistor, 27K Ω $\pm 5\%$ $\frac{1}{4}$ W
RE26	1	1	1	RT0527314	Resistor, 27K Ω $\pm 5\%$ $\frac{1}{4}$ W
RE29	1	1	1	RT0527314	Resistor, 27K Ω $\pm 5\%$ $\frac{1}{4}$ W
RE30	1	1	1	RT0527314	Resistor, 27K Ω $\pm 5\%$ $\frac{1}{4}$ W
RE31	1	1	1	RT0520314	Resistor, 20K Ω $\pm 5\%$ $\frac{1}{4}$ W
RE32	1	1	1	RT0520314	Resistor, 20K Ω $\pm 5\%$ $\frac{1}{4}$ W
RE33	1	1	1	RT0510314	Resistor, 10K Ω $\pm 5\%$ $\frac{1}{4}$ W
RE34	1	1	1	RT0510314	Resistor, 10K Ω $\pm 5\%$ $\frac{1}{4}$ W
RE35	1	1	1	RT0510314	Resistor, 10K Ω $\pm 5\%$ $\frac{1}{4}$ W
RE36	1	1	1	RT0510314	Resistor, 10K Ω $\pm 5\%$ $\frac{1}{4}$ W
RE37	1	1	1	RT0510314	Resistor, 10K Ω $\pm 5\%$ $\frac{1}{4}$ W
RE38	1	1	1	RT0510314	Resistor, 10K Ω $\pm 5\%$ $\frac{1}{4}$ W
RE39	1	1	1	RT0510314	Resistor, 10K Ω $\pm 5\%$ $\frac{1}{4}$ W
RE40	1	1	1	RT0510314	Resistor, 10K Ω $\pm 5\%$ $\frac{1}{4}$ W
RE41	1	1	1	RT0547414	Resistor, 470K Ω $\pm 5\%$ $\frac{1}{4}$ W
RE42	1	1	1	RT0547414	Resistor, 470K Ω $\pm 5\%$ $\frac{1}{4}$ W
RE43	1	1	1	RC0000012	Resistor, 0 Ω
RE44	1	1	1	RC0000012	Resistor, 0 Ω
RE45	1	1	1	RT0522514	Resistor, 2.2M Ω $\pm 5\%$ $\frac{1}{4}$ W
RE46	1	1	1	RT0522514	Resistor, 2.2M Ω $\pm 5\%$ $\frac{1}{4}$ W
RE47	1	1	1	RT0522514	Resistor, 2.2M Ω $\pm 5\%$ $\frac{1}{4}$ W
RE48	1	1	1	RT0522514	Resistor, 2.2M Ω $\pm 5\%$ $\frac{1}{4}$ W
RE49	1	1	1	RT0522514	Resistor, 2.2M Ω $\pm 5\%$ $\frac{1}{4}$ W
RE50	1	1	1	RT0522514	Resistor, 2.2M Ω $\pm 5\%$ $\frac{1}{4}$ W
RE51	1	1	1	RT0510314	Resistor, 10K Ω $\pm 5\%$ $\frac{1}{4}$ W
RE52	1	1	1	RT0510314	Resistor, 10K Ω $\pm 5\%$ $\frac{1}{4}$ W
RE53	1	1	1	RT0510314	Resistor, 10K Ω $\pm 5\%$ $\frac{1}{4}$ W
RE54	1	1	1	RT0510314	Resistor, 10K Ω $\pm 5\%$ $\frac{1}{4}$ W
RE55	1	1	1	RT0510314	Resistor, 10K Ω $\pm 5\%$ $\frac{1}{4}$ W
RE56	1	1	1	RT0510314	Resistor, 10K Ω $\pm 5\%$ $\frac{1}{4}$ W
RE57	1	1	1	RC0000012	Resistor, 0 Ω
RE58	1	1	1	RC0000012	Resistor, 0 Ω
RE59	1	1	1	RC0000012	Resistor, 0 Ω
RE60	1	1	1	RC0000012	Resistor, 0 Ω
RE61	1	1	1	RT0527214	Resistor, 2.7K Ω $\pm 5\%$ $\frac{1}{4}$ W
RE62	1	1	1	RT0510414	Resistor, 100K Ω $\pm 5\%$ $\frac{1}{4}$ W
RE63	1	1	1	RT0547414	Resistor, 470K Ω $\pm 5\%$ $\frac{1}{4}$ W
RE64	1	1	1	RT0547414	Resistor, 470K Ω $\pm 5\%$ $\frac{1}{4}$ W
RE65	1	1	1	RT0547314	Resistor, 47K Ω $\pm 5\%$ $\frac{1}{4}$ W
RE66	1	1	1	RT0547314	Resistor, 47K Ω $\pm 5\%$ $\frac{1}{4}$ W
RE67	1	1	1	RT0522114	Resistor, 220 Ω $\pm 5\%$ $\frac{1}{4}$ W
RE68	1	1	1	RT0522114	Resistor, 220 Ω $\pm 5\%$ $\frac{1}{4}$ W
RE69	1	1	1	RT0510314	Resistor, 10K Ω $\pm 5\%$ $\frac{1}{4}$ W

REF. DESIG.	QTY.			PART NO.	DESCRIPTION
	U	C	E		
RE70	1	1	1	RT0510314	Resistor, 10KΩ ±5% ¼W
RE71	1	1	1	RT0547314	Resistor, 47KΩ ±5% ¼W
RE72	1	1	1	RT0547314	Resistor, 47KΩ ±5% ¼W
RE73	1	1	1	RT0510114	Resistor, 100Ω ±5% ¼W
RE74	1	1	1	RC0000012	Resistor, 0Ω
CE05	1	1	1	DF1710552	Film Cap, 1μF ±20% 250V
CE06	1	1	1	DF1710552	Film Cap, 1μF ±20% 250V
CE07	1	1	1	DD1530001	Ceramic Cap, 30PF ±5% 50V
CE08	1	1	1	DD1530001	Ceramic Cap, 30PF ±5% 50V
CE09	1	1	1	EA1070109	Electrolytic Cap, 100μF ±5% 10V
CE10	1	1	1	EA1070109	Electrolytic Cap, 100μF ±5% 10V
CE11	1	1	1	EA1060359	Electrolytic Cap, 10μF 35V 10V
CE12	1	1	1	EA1060359	Electrolytic Cap, 10μF 35V 10V
CE13	1	1	1	EV3350356	Electrolytic Cap, 3.3μF 35V ±20%
CE14	1	1	1	EV3350356	Electrolytic Cap, 3.3μF 35V ±20%
CE15	1	1	1	DF1582205	Film Cap, 0.0082μF ±5% 50V
CE16	1	1	1	DF1582205	Film Cap, 0.0082μF ±5% 50V
CE17	1	1	1	DF1582205	Film Cap, 0.0082μF ±5% 50V
CE18	1	1	1	DF1582205	Film Cap, 0.0082μF ±5% 50V
CE19	1	1	1	DF1539301	Film Cap, 0.039μF ±5% 50V
CE20	1	1	1	DF1539301	Film Cap, 0.039μF ±5% 50V
CE21	1	1	1	DF1539301	Film Cap, 0.039μF ±5% 50V
CE22	1	1	1	DF1539301	Film Cap, 0.039μF ±5% 50V
CE23	1	1	1	DF1668205	Film Cap, 0.0068μF ±10% 50V
CE24	1	1	1	DF1668205	Film Cap, 0.0068μF ±10% 50V
CE25	1	1	1	DF6527151	Ceramic Cap, 270PF ±5% 50V
CE26	1	1	1	DF6527151	Ceramic Cap, 270PF ±5% 50V
CE27	1	1	1	DF1510205	Ceramic Cap, 1000PF ±5% 50V
CE28	1	1	1	DF1510205	Ceramic Cap, 1000PF ±5% 50V
CE29	1	1	1	DF1633205	Film Cap, 0.0033μF ±5% 50V
CE30	1	1	1	DF1633205	Film Cap, 0.0033μF ±5% 50V
CE31	1	1	1	DD1650001	Ceramic Cap, 50PF ±5% 50V
CE32	1	1	1	DD1650001	Ceramic Cap, 50PF ±5% 50V
CE33	1	1	1	EV1050256	Electrolytic Cap, 1μF ±20% 25V
CE34	1	1	1	EV1050256	Electrolytic Cap, 1μF ±20% 25V
CE35	1	1	1	EV3350356	Electrolytic Cap, 3.3μF ±20% 35V
CE36	1	1	1	EV3350356	Electrolytic Cap, 3.3μF ±20% 35V
CE37	1	1	1	EQ4750161	Electrolytic Cap, 4.7μF ±30% 16V
CE38	1	1	1	EQ4750161	Electrolytic Cap, 4.7μF ±30% 16V
CE39	1	1	1	EA2270359	Electrolytic Cap, 220μF ±5% 35V
HE01	1	1	1	HC1000121	IC, BA312
HE02	1	1	1	HC1000121	IC, BA312
HE03	1	1	1	HT313272A	Transistor, 2SC1327S.T
HE04	1	1	1	HT107212A	Transistor, 2SA721S.T
HE05	1	1	1	HT313272A	Transistor, 2SC1327S.T
HE06	1	1	1	HT107212A	Transistor, 2SA721S.T
JE01	1	1	1	YP0600028	Plug
SE01	1	1	1	RS1005007	Rotary Switch, Tone, Mode
PH01	1	1	1	YD2916005	P.W. Board
	1	1	1	ZZ2916005	P.W. Board Assembly
RH01	1	1	1	RT0510414	Resistor, 100KΩ ¼W ±5%
RH02	1	1	1	RT0510414	Resistor, 100KΩ ¼W ±5%
RH03	1	1	1	RT0512314	Resistor, 12KΩ ¼W ±5%
RH04	1	1	1	RT0512314	Resistor, 12KΩ ¼W ±5%
RH05	1	1	1	RT0510514	Resistor, 1MΩ ¼W ±5%
RH06	1	1	1	RT0510514	Resistor, 1MΩ ¼W ±5%
RH07	1	1	1	RT0510414	Resistor, 100KΩ ¼W ±5%
RH08	1	1	1	RT0510414	Resistor, 100KΩ ¼W ±5%

REF. DESIG.	QTY.			PART NO.	DESCRIPTION
	U	C	E		
RH09	1	1	1	RT0536214	Resistor, 3.6KΩ ¼W ±5%
RH10	1	1	1	RT0536214	Resistor, 3.6KΩ ¼W ±5%
RH11	1	1	1	RT0522514	Resistor, 2.2MΩ ¼W ±5%
RH12	1	1	1	RT0522514	Resistor, 2.2MΩ ¼W ±5%
RH13	1	1	1	GJ0533102	Resistor, 330Ω 2W ±5%
RH14	1	1	1	GJ0533102	Resistor, 330Ω 2W ±5%
RH15	1	1	1	GJ0515101	Resistor, 150Ω 1W ±5%
RH16	1	1	1	GJ0515101	Resistor, 150Ω 1W ±5%
CH01	1	1	1	DD1620103	Ceramic Cap, 200PF ±10%
CH02	1	1	1	DD1620103	Ceramic Cap, 200PF ±10%
CH03	1	1	1	DF1627305	Film Cap, 0.027μF 50V ±10%
CH04	1	1	1	DF1627305	Film Cap, 0.027μF 50V ±10%
CH05	1	1	1	DF1647305	Film Cap, 0.047μF 50V ±10%
CH06	1	1	1	DF1647305	Film Cap, 0.047μF 50V ±10%
CH07	1	1	1	DF1610305	Film Cap, 0.01μF 50V ±10%
CH08	1	1	1	DF1610305	Film Cap, 0.01μF 50V ±10%
JH01	1	1	1	YP1000113	Plug
JH20					
SH01	1	1	1	SP0405012	Push SW
P700	2	2	2	YD2916001	P.W. Board
	2	2	2	ZZ2928201	P.W. Board Assembly
R701	2	2	2	RT0510214	Resistor, 1.0K ¼W ±5%
R702	2	2	2	RT0533314	Resistor, 33K ¼W ±5%
R703	2	2	2	RT0568214	Resistor, 6.8K ¼W ±5%
R704	2	2	2	RT0510214	Resistor, 1K ¼W ±5%
R705	2	2	2	RT0510114	Resistor, 100K ¼W ±5%
R706	2	2	2	RT0556314	Resistor, 56K ¼W ±5%
R707	2	2	2	RA0502017	Trimming Resistor, 5K(B)
R708	2	2	2	RT0547214	Resistor, 4.7K ¼W ±5%
R709	2	2	2	RT0518414	Resistor, 180K ¼W ±5%
R710	2	2	2	RT0516214	Resistor, 1.6K ¼W ±5%
R711	2	2	2	RT0522314	Resistor, 22K ¼W ±5%
R712	2	2	2	RT0518214	Resistor, 1.8K ¼W ±5%
R713	2	2	2	RC1010212	Resistor, 1K ¼W ±10%
R714	2	2	2	RT0533314	Resistor, 33K ¼W ±5%
R715	2	2	2	RT0547214	Resistor, 4.7K ¼W ±5%
R716	2	2	2	GF0533014	Resistor, 33K ¼W ±5%
R717	2	2	2	HH0000303	Thermistor, STD04
R718	2	2	2	RT0575014	Resistor, 75K ¼W ±5%
R719	2	2	2	RA0301002	Trimming Resistor, 300 (E)
R720	2	2	2	GF0530114	Resistor, 300K ¼W ±5%
R721	2	2	2	GF0568114	Resistor, 680 ¼W ±5%
R722	2	2	2	GF0547214	Resistor, 4.7K ¼W ±5%
R723	2	2	2	GF0522214	Resistor, 2.2K ¼W ±5%
R724	2	2	2	GF0522214	Resistor, 2.2K ¼W ±5%
R725	2	2	2	GF0510114	Resistor, 100 ¼W ±5%
R726	2	2	2	GF0510114	Resistor, 100 ¼W ±5%
R727	2	2	2	GF0510114	Resistor, 100 ¼W ±5%
R728	2	2	2	GF0522114	Resistor, 220 ¼W ±5%
R729	2	2	2	GF0510014	Resistor, 10 ¼W ±5%
R730	2	2	2	GF0510014	Resistor, 10 ¼W ±5%
R731	2	2	2	GF0522114	Resistor, 220 ¼W ±5%
R732	2	2	2	GW1020205	Resistor, 0.2 5W ±10%
R733	2	2	2	GW1020205	Resistor, 0.2 5W ±10%
R734	2	2	2	RC1002212	Resistor, 2.2 ¼W ±10%
R735	2	2	2	GJ0510002	Resistor, 10 2W ±5%
R736	2	2	2	GF0510114	Resistor, 100Ω ¼W ±5%
R737	2	2	2	RC0000012	Resistor, 0Ω

U: For U.S.A.
C: For Canada
E: For Europe

REF. DESIG.	QTY.			PART NO.	DESCRIPTION
	U	C	E		
C701	2	2	2	EE3350251	Electrolytic Cap, 3.3 μ F 25V \pm 20%
C702	2	2	2	EA1060359	Electrolytic Cap, 10 μ F 35V
C703	2	2	2	DD1620101	Ceramic Cap, 200PF 50V
C704	2	2	2	EA4760509	Electrolytic Cap, 4.7 μ F 50V
C705	2	2	2	EE4760162	Electrolytic Cap, 4.7 μ F 10V \pm 20%
C706	2	2	2	EA2270509	Electrolytic Cap, 220 μ F 50V
C707	2	2	2	DD1003050	Ceramic Cap, 3PF 500V
C708	2	2	2	DF1710305	Film Cap, 0.01 μ F 50V
C709	2	2	2	DF1710305	Film Cap, 0.01 μ F 50V
C710	2	2	2	DF1710452	Film Cap, 0.1 μ F 200V
C711	2	2	2	DK1622151	Ceramic Cap, 220PF 500V
C712	2	2	2	DK1622201	Ceramic Cap, 0.002 μ F 50V
C713	2	2	2	DK1610150	Ceramic Cap, 100PF 500V
J701 }	2	2	2	YP1000114	Plug
J706					
J708 }	2	2	2	YP1000114	Plug
J714					
H701	2	2	2	HD3003009	Diode, WZ-177
H702	1	1	1	HT107631B	Transistor, 2SA763 (45)
H703	1	1	1	HT107631B	Transistor, 2SA763 (45)
H704	2	2	2	HV0000312	Diode, MV-13
H707	2	2	2	HT308753B	Transistor, 2SC875 C.D.E
H708	2	2	2	HD2000221	Diode, 1S2472 (Gr)
H709	2	2	2	HD2000221	Diode, 1S2472 (Gr)
H710	2	2	2	HT309451Q	Transistor, 2SC945 Q
H711	2	2	2	HT107331Q	Transistor, 2SA733 Q
H712	2	2	2	HD2000221	Diode, 1S2472 (Gr)
H713	2	2	2	HD2000221	Diode, 1S2472 (Gr)
H714	1	1	1	HT404151Q	Transistor, 2SD415 P.Q.R
H715	1	1	1	HT205491Q	Transistor, 2SB549 P.Q.R
L701	2	2	2	LC2262001	Coil
P800	1	1	1	YD2916002	P.W. Board
	1	1	1	ZZ2928302	P.W. Board Assembly
R801	1	1	1	GF0510012	Resistor, 10 Ω $\frac{1}{2}$ W \pm 5%
R802	1	1	1	RT0547214	Resistor, 4.7K $\frac{1}{2}$ W \pm 5%
R803	1	1	1	RT0547214	Resistor, 4.7K $\frac{1}{2}$ W \pm 5%
R804	1	1	1	RT0539214	Resistor, 3.9K $\frac{1}{2}$ W \pm 5%
R805	1	1	1	RT0522314	Resistor, 22K $\frac{1}{2}$ W \pm 5%
R806	1	1	1	RA0502013	Trimming Resistor, 5K (B)
R807	1	1	1	GS1015105	Resistor, 150 Ω 5W \pm 10%
R808	1	1	1	RT0533214	Resistor, 3.3K $\frac{1}{2}$ W \pm 5%
R809	1	1	1	RT0510014	Resistor, 10 Ω $\frac{1}{2}$ W \pm 5%
R810	1	1	1	RT0527314	Resistor, 27K $\frac{1}{2}$ W \pm 5%
R811	1	1	1	RT0522314	Resistor, 22K $\frac{1}{2}$ W \pm 5%
R812	1	1	1	RT0568214	Resistor, 6.8K $\frac{1}{2}$ W \pm 5%
R813	1	1	1	RT0524414	Resistor, 240K $\frac{1}{2}$ W \pm 5%
R814	1	1	1	RT0539314	Resistor, 39K $\frac{1}{2}$ W \pm 5%
R815	1	1	1	GU0539112	Resistor, 390 Ω $\frac{1}{2}$ W \pm 5%
R816	1	1	1	GU0556212	Resistor, 5.6K $\frac{1}{2}$ W \pm 5%
R817	1	1	1	GU0556212	Resistor, 5.6K $\frac{1}{2}$ W \pm 5%
R818	1	1	1	RT0556214	Resistor, 5.6K $\frac{1}{2}$ W \pm 5%
C801	1	1	1	EA2270631	Electrolytic Cap, 220 μ F 63V
C802	1	1	1	EA1070509	Electrolytic Cap, 100 μ F 50V
C803	1	1	1	DF1710305	Film Cap, 0.01 μ F 50V
C804	1	1	1	EA2260359	Electrolytic Cap, 22 μ F 35V

REF. DESIG.	QTY.			PART NO.	DESCRIPTION
	U	C	E		
C805	1	1	1	EA3370509	Electrolytic Cap, 330 μ F 50V
C806	1	1	1	EA4770169	Electrolytic Cap, 470 μ F 16V
C807	1	1	1	EA4750509	Electrolytic Cap, 4.7 μ F 50V
C808	1	1	1	EA4760169	Electrolytic Cap, 47 μ F 16V
C809	1	1	1	EA2270109	Electrolytic Cap, 220 μ F 10V
C810	1	1	1	DK1810351	Ceramic Cap, 0.01 μ F 200V
H801	1	1	1	HT403302A	Transistor, 2SD330 DE
H802	1	1	1	HT313183A	Transistor, 2SC1318 P.Q.R
H803	1	1	1	HT309452A	Transistor, 2SC945 Q.R.
H804	1	1	1	HT403314A	Transistor, 25D331 C.D.E.F
H805	1	1	1	HT309452A	Transistor, 2SC945 Q.R
H806	1	1	1	HT313182R	Transistor, 2SC1318 RS
H807	1	1	1	HT313182R	Transistor, 2SC1318 RS
H808	1	1	1	HD2001103	Diode, DS131-B
H809	1	1	1	HD3002309	Diode, WZ-071
H810	1	1	1	HD3002709	Diode, WZ-140
H811	1	1	1	HD2001103	Diode, DS131B
H812	1	1	1	HD2000321	Diode, 1S2471
L801	1	1	1	LY2024006	Relay, MY 2 24V
J801 }	1	1	1	YP1000113	Plug
J810					
J001	1	1	1	YT0101003	Terminal, Ground
J002	1	1	1	YT0201009	Terminal, Quad Out 1P
J003	1	1	1	YT0204008	Terminal, Phono Aux 4P
J004	1	1	1	YT0208006	Terminal, Tape 1.2 8P
J005	1	1	1	YJ0100081	Jack, Dubbing In
J006	1	1	1	YJ0100098	Jack, Dubbing Out
J007	1	1	1	YL0103018	Terminal, Dubbing 3P
J008	1	1	1	YJ0800019	Socket, Meter Lamp
J009	1	1	1	YJ0800019	Socket, Meter Lamp
J010	1	1	1	YT0204011	Terminal, Pre-Main
J013	1	1	1	YJ0100098	Jack, Head Phone
J014	1	1	1	YT0304012	Terminal, Main Speaker
J015	1	1	1	YT0304012	Terminal, Remote Speaker
J016	1	1	1	YJ0500019	Socket, TR Socket
J017	1	1	1	YJ0500019	Socket, TR Socket
J018	1	1	1	YJ0500019	Socket, TR Socket
J019	1	1	1	YJ0500019	Socket, TR Socket
J020	1	1	1	YJ0800012	Socket, Fuse Holder
J021	1	1	1	YJ0400048	Socket, Socket, Outlet
J022	1	1	1	YJ0400048	Socket, Socket, Outlet
J027	1	1	1	YJ0600019	Socket, 7P Tone Pre.
M001	1	1	1	IM1104203	Meter, Signal
M002	1	1	1	IM1104202	Meter, FM
M003	1	1	1	IN1008007	Lamp, Meter Lamp
M004	1	1	1	IN1008007	Lamp, Meter Lamp
R001	1	1	1	RM0254022	Variable Resistor, Volume 250K
R002	1	1	1	RS0504002	Variable Resistor, Balance 500K
R003	1	1	1	RC1047012	Resistor, 47 Ω \pm 10% $\frac{1}{2}$ W
R004	1	1	1	RT0510414	Resistor, 100K \pm 5% $\frac{1}{2}$ W
R005	1	1	1	RC1022512	Resistor, 2.2M Ω \pm 10% $\frac{1}{2}$ W
R006	1	1	1	RT0510514	Resistor, 1M Ω \pm 5% $\frac{1}{4}$ W
R007	1	1	1	RT0510514	Resistor, 1M Ω \pm 5% $\frac{1}{4}$ W
R008	1	1	1	RT0543214	Resistor, 4.3K \pm 5% $\frac{1}{4}$ W
C001	1	1	1	DK1810301	Ceramic Cap, 0.01 μ F 50V
C002	1	1	1	DK1840301	Ceramic Cap, 0.04 50V
C003	1	1	1	EA3360109	Electrolytic Cap, 33 μ F 10V

REF DESIG.	QTY.			PART NO.	DESCRIPTION
	U	C	E		
C004	1	1	1	EC1090502	Electrolytic Cap, 10000 μ F 50V
C005	1	1	1	EC1090502	Electrolytic Cap, 10000 μ F 50V
C006	1	1	1	DK1810301	Ceramic Cap, 0.01 μ F 50V
C007	1	1	1	DK1810301	Ceramic Cap, 0.01 μ F 50V
C008	1	1	1	DK1810351	Ceramic Cap, 0.01 μ F 500V
C009			1	DF1722380	Film Cap, 0.02 μ F 1000V
L001	1	1	1	LF1120038	Ant. Coil, AM
L002	1	1	1	LC1332002	Choke Coil, 3.3 μ H
L003	1	1	1	LC1332002	Choke Coil, 3.3 μ H
L004	1	1		TS6140501	Power Transformer
L004			1	TS6140502	Power Transformer
S001	1	1	1	SR1006015	Rotary Switch
S002	1	1	1	SP0201015	Push Switch, Power
G001	1	1		BF1040002	Printed Comp.
H001	1	1	1	HT313431B	Transistor, 2SC1343 B.C
H002	1	1	1	HT313431B	Transistor, 2SC1343 B.C
H003	1	1	1	HT313431B	Transistor, 2SC1343 B.C
H004	1	1	1	HT313431B	Transistor, 2SC1343 B.C
H005	1	1	1	HV0000212	Diode
H006	1	1	1	HV0000212	Diode
H007	1	1	1	HD2001705	Diode
F001	1	1		FS1050004	Fuse, 5AUL
F002			1	FS2050091	Fuse, 5AUL
F001	1	1	1	FS1050005	Fuse, 5A
W001	1	1		YC0240010	AC Cord
W001			1	YC0190003	AC Cord
PR01 FUSE BOARD					
PR01			1	YD2871003	P.W. Board
			1	ZZ2871803	P.W. Board Assembly
JR01 ?			1	YJ0800020	Jack
JR08					
JR09 ?			1	YP1000099	Plug
JR16					
FR01			1	FS1040090	Fuse
FR02			1	FS1010090	Fuse
FR03			1	FS1010090	Fuse
FR04			1	FS1040090	Fuse
J023			1	YL0106004	Terminal
	1	1	1	292885501	Service Manual

REF. DESIG.	QTY.			PART NO.	DESCRIPTION
	U	C	E		
PC01	1	1	1	YD2916003	PC01 DOLBY LEVEL BOARD P.W. Board
	1	1	1	ZZ2916003	P.W. Board Assembly
RC01	1	1	1	RA0104015	Trimming Resistor, 100K (B)
RC02	1	1	1	RA0104015	Trimming Resistor, 100K (B)
RC03	1	1	1	RT0568314	Resistor, 68K $\frac{1}{4}$ W \pm 5%
RC04	1	1	1	RT0568314	Resistor, 68K $\frac{1}{4}$ W \pm 5%
RC05	1	1	1	RT0510414	Resistor, 100K $\frac{1}{4}$ W \pm 5%
RC06	1	1	1	RT0510414	Resistor, 100K $\frac{1}{4}$ W \pm 5%
RC07	1	1	1	RT0539214	Resistor, 3.9K $\frac{1}{4}$ W \pm 5%
RC08	1	1	1	RT0539214	Resistor, 3.9K $\frac{1}{4}$ W \pm 5%
RC09	1	1	1	RT0510414	Resistor, 100K $\frac{1}{4}$ W \pm 5%
RC10	1	1	1	RT0510414	Resistor, 100K $\frac{1}{4}$ W \pm 5%
CC01	1	1	1	EV1050256	Electrolytic Cap., 1 μ F 25V
CC02	1	1	1	EV1050256	Electrolytic Cap., 1 μ F 25V
CC03	1	1	1	EV1050256	Electrolytic Cap., 1 μ F 25V
CC04	1	1	1	EV1050256	Electrolytic Cap., 1 μ F 25V
JC01	1	1	1	YP1000113	Plug
JC02	1	1	1	YP1000113	Plug
JC03	1	1	1	YP1000113	Plug
JC04	1	1	1	YP1000113	Plug
JC05	1	1	1	YP1000113	Plug
JC06	1	1	1	YP1000113	Plug
JC07	1	1	1	YP1000113	Plug
JC08	1	1	1	YP1000113	Plug
HC01	1	1	1	HT313272A	Transistor, 2SC1327S.T.
HC02	1	1	1	HT313272A	Transistor, 2SC1327S.T.

SERVICE INFORMATION FOR EUROPEAN MODEL

The information contained herein includes rear panel and main chassis component locations, voltage conversion, schematic diagram and technical specifications. For the alignment procedures, test equipment, and repairing hints, refer to the original service manual.

TABLE OF CONTENTS

Technical Specifications	38
Rear Panel Jacks and Component Locations	40
Main Chassis Component Locations (Top View)	40
Voltage Conversion	41
Voltage Conversion Chart	41
Schematic Diagram	42

TECHNICAL SPECIFICATIONS

Amplifier Section:

RATED POWER OUTPUT	50 Watts per channel, Continuous Average Power, both channels driven.
Power Band	20 Hz to 20 kHz
Total Harmonic Distortion	0.3%
Load Impedance	8 ohms
Intermodulation Distortion at Rated Power	0.25%
Damping Factor	55
Frequency Response	20 Hz to 20 kHz ± 0.5 dB

Preampifier Section:

Phono:

Dynamic Range	96 dB
---------------------	-------

NOTE: Dynamic Range is the ratio in dB
of the phono input overload to
equivalent input noise.

Equivalent Input Noise	1.5 μ V
Input Overload	100 mV
Sensitivities (for rated power output)	
Phono	1.8 mV
Tape	180 mV

Main In	1.5 V
Frequency Response (phono)	30 Hz to 15 kHz \pm 1.0 dB
Input Impedances	
Phono	47 K ohms
Aux or Tape	100 K ohms
Main In	30 K ohms
Tape Output Level	775 mV
Ref.: 7.75 mV at phono input	
Signal to Noise Ratio	
Aux Input	85 dB
Phono Input	75 dB
Tone Controls	
Bass: 100 Hz	\pm 10 dB
Tone Mode at 250 Hz	\pm 3 dB
Mid: 700 Hz	\pm 7.5 dB
Treble: 10 kHz	\pm 10 dB
Tone Mode at 4 kHz	\pm 3 dB

FM Tuner Section:

IHF Usable Sensitivity	2.5 μ V
Sensitivity (DIN)	2.1 μ V
Selectivity (alternate carrier)	60 dB
Quieting Slope	
RF Input for 30 dB Quieting	1.9 μ V
Quieting at 5 μ V RF Input	55 dB
Quieting at 10 μ V RF Input	60 dB
Quieting at 50 μ V RF Input	70 dB
Total Harmonic Distortion	
Mono:	0.3%
Stereo:	0.4%
Capture Ratio	1.5 dB
Stereo Separation at 1 kHz	40 dB
Spurious Rejection	95 dB
Image Rejection	70 dB
IF Rejection	90 dB
AM Suppression	55 dB

AM Tuner Section:

Sensitivity	20 μ V
-------------------	------------

General:

Power Requirements	110/120/220/240 V AC, 50 Hz
Power Consumption at rated output, both channels operating	220 Watts
Idling Power (Volume Control at zero)	35 Watts
Dimensions:	
Panel Width	43.1 cm
Panel Height	13.6 cm
Depth	35.6 cm
Weight:	
Unit Alone	15.3 kg
Packed for Shipment	18.3 kg

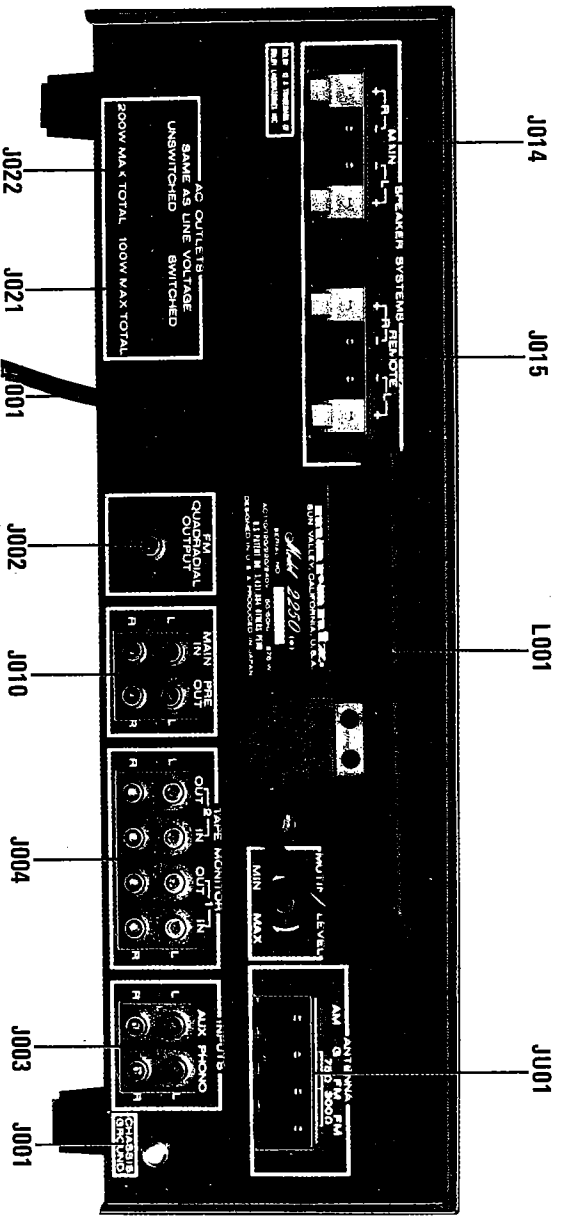

Figure 24. Rear Panel Adjustments and Component Locations for European Model

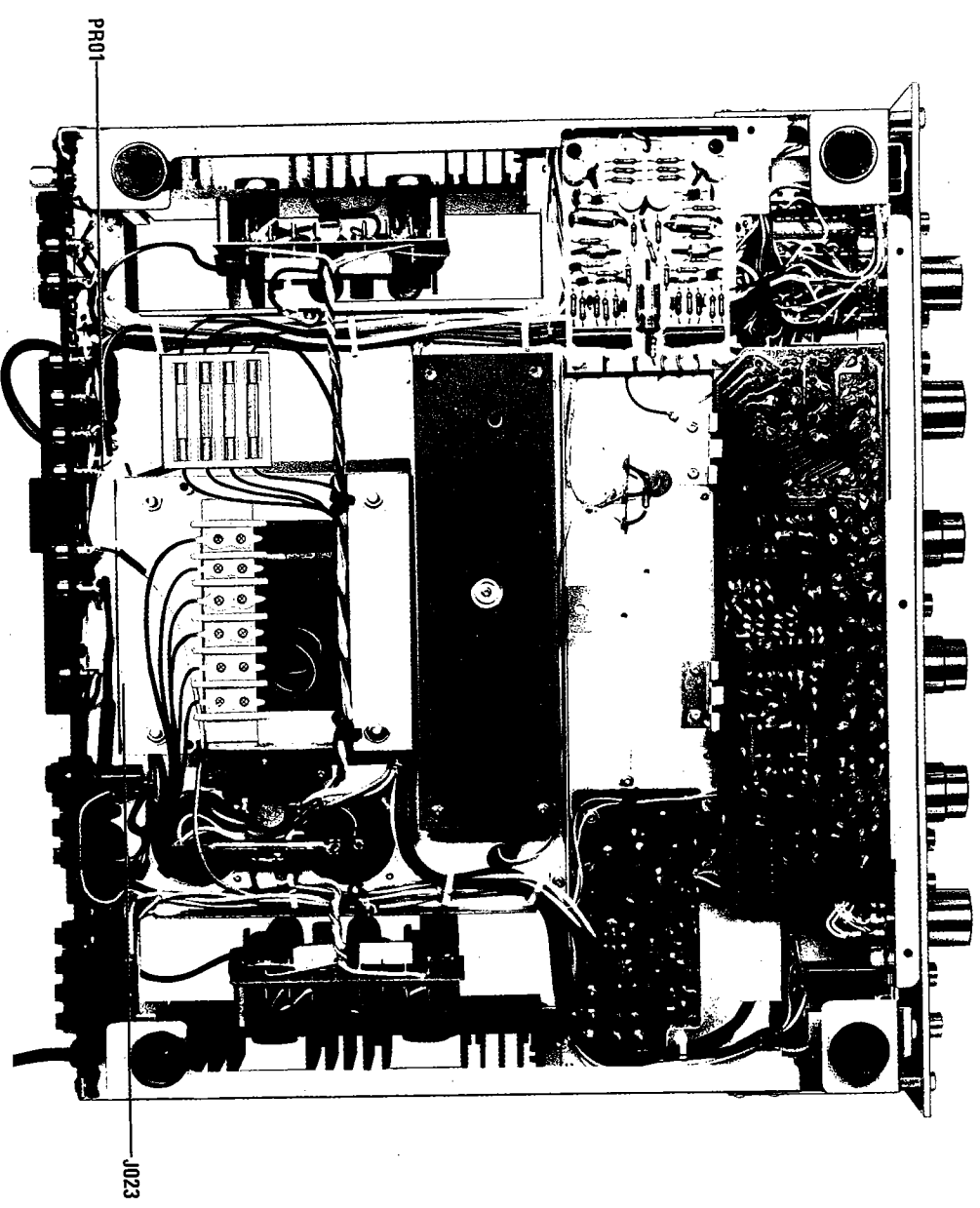

Figure 25. Main Chassis Component Locations (Bottom View) for European Model

VOLTAGE CONVERSION
 This Model is equipped with a universal power transformer to permit operation at 110, 120, 220 and 240 V AC 50/60 Hz.
 To convert the unit to the required voltage, set the plug as illustrated so that you can adjust the voltage as required.

CAUTION: DISCONNECT POWER SUPPLY CORD FROM AC OUTLET BEFORE CONVERTING VOLTAGE.

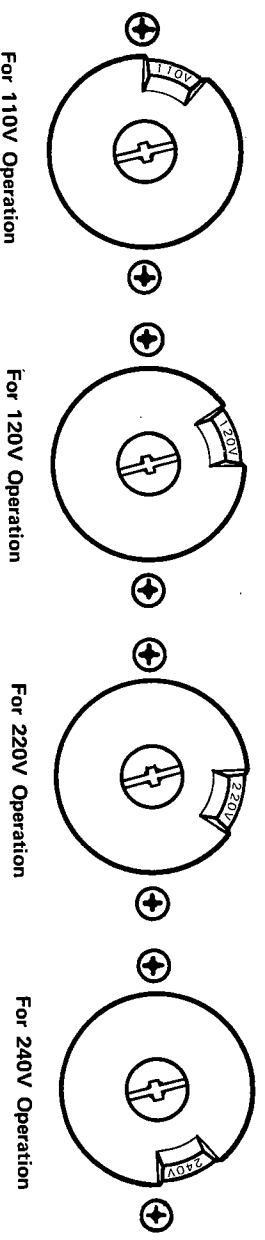
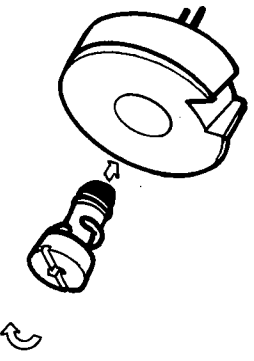
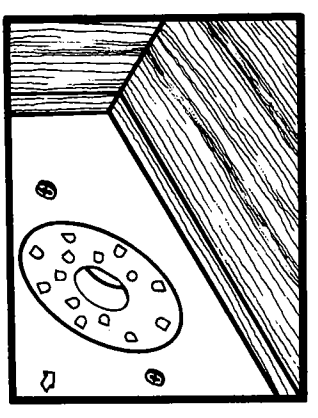
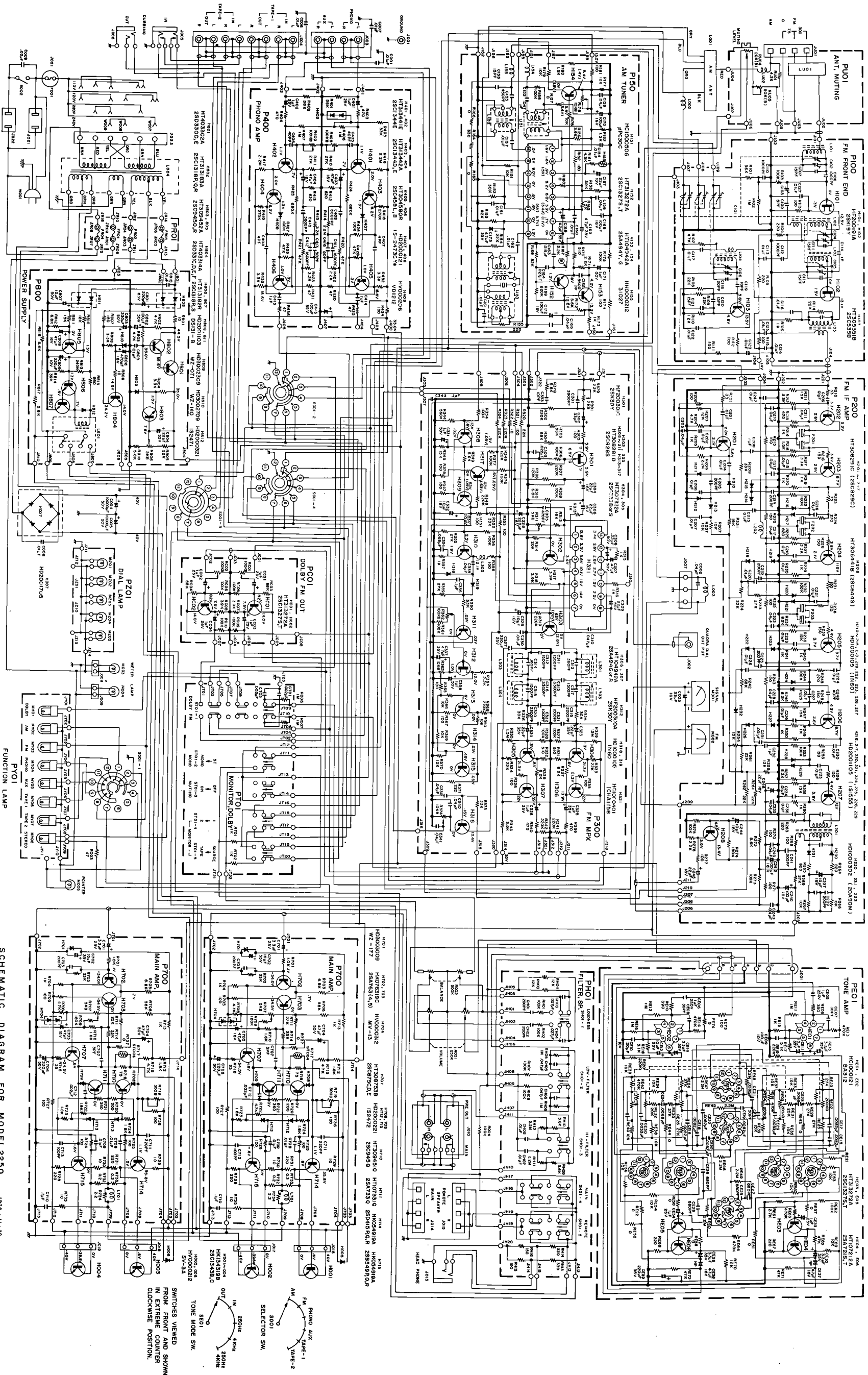

Figure 26. Conversion Chart



SCHEMATIC DIAGRAM FOR MODEL 2250

Figure 27. Schematic Diagram for European Model