

MAR 28 REC'D

SERVICE MANUAL



marantz

model 2240

Stereophonic Receiver

TABLE OF CONTENTS

SECTION	PAGE
Introduction	1
Service Notes	1
AM Tuner	1
FM Tuner	3
Phono and Tone Amplifiers	5
Power Amplifier	5
Power Protection Circuit	6
Speaker Protector Relay Circuit	6
Suggestions for Trouble Shooting of Power Amplifier	7
Test Equipment Required for Servicing	8
AM Alignment Procedure	8
FM Alignment Procedure	9
Stereo Separation Alignment	9
Muting Circuit Alignment	9
Audio Adjustment	10
Parts List	26
Specifications	37
Service Information for European Model	38
TABLE	
1. Test Equipment Required for Servicing	8

LIST OF ILLUSTRATIONS

FIGURE	PAGE
1. Block Diagram of the HA1156	2
2. Remove the Terminal Cover	6
3. Dial Stringing	11
4. Front Panel Adjustment and Component Locations	12
5. Main Chassis Component Locations (Top View)	12
6. Rear Panel Adjustment and Component Locations	13
7. Main Chassis Component Locations (Bottom View)	13
8. FM Front End Assembly P100 Component Locations	14
9. AM Tuner Unit Assembly P150 Component Locations	14
10. FM IF Amplifier Assembly P200 Component Locations	15
11. MPX Stereo Decoding Amplifier Assembly P300 Components Locations	15
12. Phono Amplifier Assembly P400 Component Locations	16
13. Power Amplifier Assembly P700 Component Locations	16
14. Power Supply Assembly P800 Component Locations	17
15. Dolby Level Assembly PC01 Component Locations	17
16. Dial Lamp Assembly PZ01 Component Locations	18
17. Functions Lamp Assembly PY01 Component Locations	18
18. Pre-Tone Amplifier Assembly PE01 Component Locations	18
19. High and Low Filter and Muting Switch Unit Assembly PH01 Component Locations ...	19
20. Monitor Dolby Assembly PT01 Component Locations	19
21. ANT. Muting Assembly PU01 Component Locations	20
22. Exploded Mechanical Diagram	22
23. Schematic Diagram	24
24. Rear Panel Adjustments and Component Locations for European Model	39
25. Main Chassis Component Locations (Bottom View) for European Model	39
26. Voltage Conversion Chart	40
27. Schematic Diagram for European Model	42

INTRODUCTION

This service manual was prepared for use by Authorized Warranty Stations and contains service information for Marantz Model 2240 Stereo-phonics Receiver.

Service information and voltage data included in this manual are intended for use by the knowledgeable and experienced technician only. All instructions should be read carefully. No attempt should be made to proceed without a good understanding of the operation in the receiver.

The parts list furnishes information by which replacement parts may be ordered from the Marantz Company. A simple description is included for parts which can usually be obtained through local suppliers.

1. SERVICE NOTES

As can be seen from the circuit diagram the chassis of Model 2240 consists of the following units. Each unit mounted on a printed circuit board is described within the square enclosed by a bold dotted line on the circuit diagram.

1. FM Front End	Mounted on P.W. Board, P100
2. AM Tuner	Mounted on P.W. Board, P150
3. FM - IF	Mounted on P.W. Board, P200
4. MPX	Mounted on P.W. Board, P300
5. ANT-ATT. Muting UR	Mounted on P.W. Board, PU01
6. Dolby Level	Mounted on P.W. Board, PC01
7. Phono Amp	Mounted on P.W. Board, P400
8. Dial Lamp	Mounted on P.W. Board, PZ01
9. Monitor, SW	Mounted on P.W. Board, PT01
10. Function Lamp	Mounted on P.W. Board, PY01
11. Pre Tone Amp.	Mounted on P.W. Board, PE01
12. Filter, SP SW	Mounted on P.W. Board, PH01
13. Power Amp	Mounted on P.W. Board, P700
14. Power Supply	Mounted on P.W. Board, P800

2. AM TUNER

The AM TUNER portion of the 2240 is composed of one IC circuit (including RF amplifier, local oscillator, mixer, IF amplifier, and detector) and three transistors. One of them is a signal strength indication amplifier, while the other two are amplifiers for detected audio signals.

All components except Tuning capacitor and ferrite bar antenna are mounted on a printed circuit board P150.

The AM signals induced in a ferrite bar antenna are applied to the input of RF amplifier (pin 12) and amplified to the level required for overcoming the conversion noises, thus giving good S/N performance. The tuned circuits inserted in both output and input circuit of RF amplifier assure very high image and spurious rejection performance.

Thus amplified and selected AM signals are then applied to one input of Mixer section (pin 1). While the local oscillator voltage is injected to the other input of the section (pin 16) through a capacitor C157. Then both AM signals and oscillating voltage are mixed and converted into 455 KHz intermediate frequency. The resulting IF signal is applied to the IF transformer L153 consisting of one ceramic filter and two tuned circuits.

The output of L153 is led to the IF amplifier's input (pin 9) through a coupling capacitor C162 and amplified to the sufficient level to drive the detector. The detected audio signal derived from pin 7 is filtered and amplified and final audio output is obtained from the collector of H153 and applied to the TAPE OUTPUT jacks through the function switch.

The DC component of the detected IF signal is used as a AGC voltage to control emitter current of RF amplifier through the AGC amplifier incorporated in the IC. A part of the DC component is also applied to the signal strength indication amplifier H154. The output appears at the collector of H154 and is level adjusted by R178, indicated on the signal strength meter M004.

2.1 Suggestions for AM Tuner Trouble Shooting

Check for broken AM bar antenna, next try to tune station by rotating fly-wheel tuning knob slowly and observe the AM signal strength meter whether it deflects or not. If the signal strength meter gives a deflection at several frequencies received, no failure may exist in the stages at least preceding the detector circuit. Next connect a oscilloscope to the test point B or J161 and check for audio signals with the tuning meter deflected. If the signal strength meter does not deflect, check the local oscillator circuit. Normal oscillating voltage at the hot end of the oscillator tuning capacitor is about 1.5 or 3 volts, varying with tuning capacitor position. When measuring oscillating voltage use a RF VTVM, no circuit tester gives correct indication. If the local oscillator voltage is normal, check all voltage distribution in the AM circuits by using a DC VTVM and compare the measured values with those given in the schematic diagram.

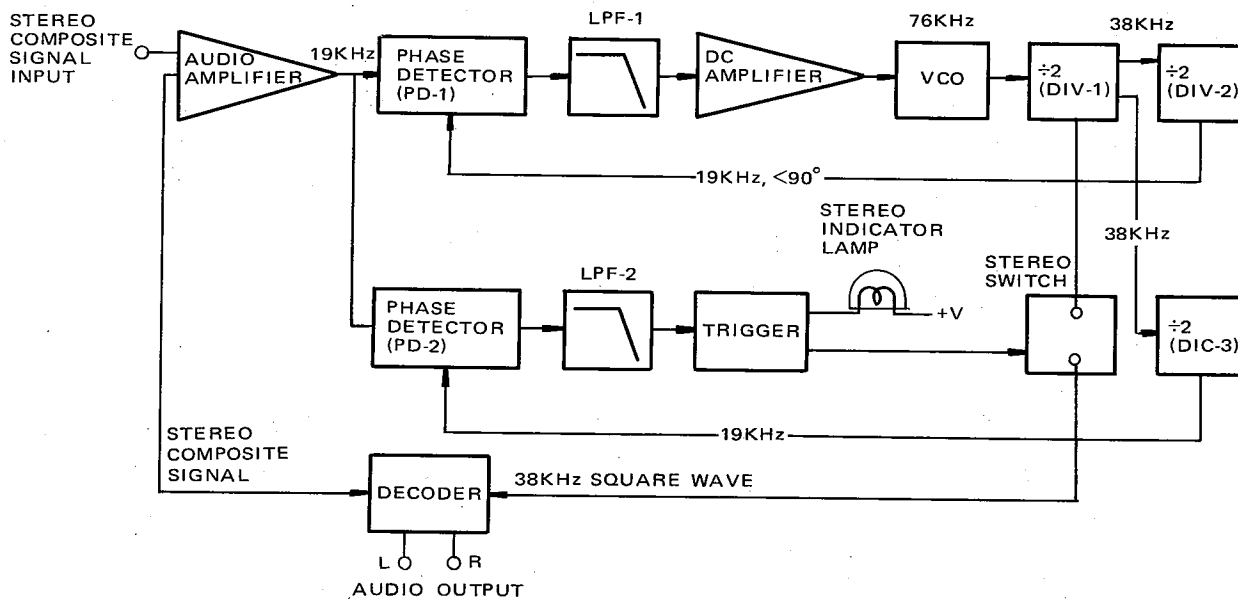

Figure 1. Block Diagram of the HA1156

3. FM TUNER

The FM Tuner section of Model 2240 is divided into four functional blocks: FM Front End, IF Amplifier and Detector, Muting Control, and MPX Stereo Decoding Circuit. FM signals induced by a FM antenna are led to FM antenna coil L101 through a balun coil. These signals are then applied to the FET RF amplifier which in turn applies its output to the next FET Mixer H102 through the double tuned high selective circuits. The FET Mixer convert its input signal into 10.7 MHz intermediate frequency and amplifies it at the same time. The H103 is a local oscillator and its output is injected into the source of the FET Mixer, the injection voltage is about 700 mV. The 10.7 MHz front end output is led to the next IF amplifier unit through a coaxial cable.

The IF amplifier unit consists of five stages of IF amplifier and one stage of AGC amplifier. Three pieces of dual elements ceramic filters are also used to obtain high selectivity, four stages of symmetrical diode limiters are also employed for the best limiting characteristics, improved capture ratio and good AM suppression.

A part of FM Front End output is applied to the AGC amplifier H201 and its rectified output is fed back to the gate of FET RF amplifier to decrease the gain with increased signal strength.

The IF signal sufficiently amplified through every stage of IF amplifier is finally applied to the detector amplifier. The detected audio output is led to the buffer amplifier H208 and its buffered output is led to; (a) noise amplifier H310 through resistor R378 and capacitor C333, (b) QUADRADIAL jack on the rear panel through resistor R379, (c) MPX stereo decoding IC (H321) through R301 and H301.

3.1 Audio Muting and Stereo Mode Auto-Selecting Circuit

The muting circuit consisting of all solid-state electrical switching has been incorporated in the Model 2240. Three inputs control the muting function. The first is related to signal strength, the second to the noise condition at the detector and the third is derived from the DC component of the detector output. These inputs are properly matrixed and gated to provide muting free from noise and transients.

The first input of DC voltage obtained by rectifying a part of IF output signal from the H205 and H206 is applied to the base of H308 and turns on it, if the IF output is greater than predetermined level (muting threshold level). When the H308 is turned on the H309 is turned off, allowing the emitter-collector resistance increasing and the collector voltage rises about 9V. The increased collector voltage increases the gate bias voltage and turns on the switching FET H301, decreasing the source-drain resistance to near zero ohm and allowing the audio signal applied to the source to flow to the pin 2 of decoding IC through the source-drain path.

When the input signal is lower than predetermined level, the DC output obtained is small and can not turn on the H308 thus the H308 keeps its turn-off stage and this makes H309 turn on, decreasing the collector voltage and turning off H301. Thus no audio signals can pass through the FET. This is the fundamental principle of the muting operation but for more elaborate muting operation the second and the third inputs are necessary.

The second input is used to protect the muting operation and MPX stereo beacon lamps from misoperation due to undesirable noises. The high frequency noises included in the detected audio signals are separated by a small capacitor C333 and amplified by the noise amplifier transistor H310 and its output is rectified by the two diodes. The rectified DC output is proportional to the noise components in the audio signals.

When there are excessive noises in the audio signals such as obtained with a station incorrectly tuned in, the rectified DC output turns on the transistor H311, decreasing the emitter-collector resistance to zero. This means the collector of H309 is short-circuited to the ground, therefore the H301 is turned off and any audio signals having excessive high frequency noises can not go through the FET's source-drain path.

The transistor H317, also, turns off when transistor H309 or H311 turns on, and turns on the transistor H303 connected to pin 8 of the MPX stereo decoding IC. Pin 8 is therefore grounded equivalently to set the IC in the monaural mode of operation. This prevents misoperation due to undesirable noises when the FM tuner is out of tuning.

The third input is obtained from the FM discriminator circuit. The DC output so called "S" curve is applied to the gate of H312 through a resistor R273 and dividing network (R361 & R362). The DC output is zero with a station correctly tuned in, but will vary from negative to positive values or vice versa when the tuning point is deviated toward either plus or minus frequency from the correct tuning frequency.

When the DC output is increased to a greater level than that of predetermined, the increased source potential of H312 makes the transistor H315 turn on (this means the collector of H309 is short-circuited to the ground) ... H301 turn off, ... H317 turn off ... H303 turn on (This grounds pin 8 of the MPX stereo decoding IC, therefore the decoder is set in the monaural mode of operation and the stereo indicator lamp turns off). When the DC output is increased to the negative predetermined level, the decreased source potential turns off the H313 which in turn makes the H314 turn on (this means the collector of H309 is short-circuited to the ground). The subsequent changes are exactly the same as that just described above.

Thus when the tuning is shifted-or-deviated to the certain frequencies in which undesirable noisy side-audio signals are produced, both muting and MONAURAL/STEREO switching transistors H303 are operated automatically and open the circuits.

With the station correctly tuned in, the bias current of the FET H312 is adjusted so that both transistor H314 and H315 are not turned on, giving no effect on the transistor H308.

3.2 MPX Stereo Decoding Circuit

The stereo composite signal from the buffer amplifier undergoes a phase compensation by R301 and C301, is applied through the muting switching FET H301 to the input terminal, pin 2, of the MPX stereo decoding IC H321 on a PLL (Phase Locked Loop) basis, and decoded into the left and right stereo signals, which become available at pins 4 and 5 respectively. These decoded left and right stereo audio signals are introduced through a low pass filter composed of L301 to L304 and C311 to C320 for elimination of undesirable residual switching signal and through a de-emphasis network consisting of R325, R326, C321 and C322, into the npn-pnp direct coupled audio amplifier, where the signals are amplified to a required level for the output from J311 and J313. From these jacks, the audio signals are led to the TAPE OUTPUT jacks through the function switch. Figure 1 presents an internal block diagram showing the functions of the PLL basis MPX stereo decoding IC HA1156. The input stereo composite signal, amplified by the audio amplifier, is delivered to the phase detectors PD-1 and PD-2. A part of the stereo composite signal is also applied to the stereo decoder section. The VCO (Voltage Control Oscillator) produces a free run oscillation in the neighborhood of 76 KHz with the time constant determined by a capacitor C305 and resistors R311 and R312 set on the outside of pin 14. The VCO output has its frequency divided into 10 KHz through the two stages of the frequency divider (DIV-1 & DIV-2), and is reverted to the phase detector PD-1, which contains two input terminals designed to produce an output in proportion to the product of the two input signals. The signal applied to one of the inputs of PD-1 is the 19 KHz square wave formed through frequency division of the 76 KHz VCO output signal by the two stages of the frequency divider DIV-1 and DIV-2, and the 19 KHz pilot signal included in the stereo composite signal as a reference signal is applied to the other input. Therefore, the output of PD-1 which has passed through the low pass filter LPF-1 provides DC output voltage in proportion to the phase variance between the two inputs. This DC output voltage is amplified by the DC amplifier, and supplied to the 76 KHz VCO as a control voltage. This means that the output frequency and phase of the VCO have been phase-locked to the input pilot signal. The 38 KHz sub-carrier reproduced by PLL as stated above is delivered through the stereo switch to the stereo decoder section as a switching signal, thus driving the decoder section. One of the

inputs of PD-2 is given the 19 KHz resulting from the frequency division completed by DIV-1 and DIV-3, whereas the other input gets the 19 KHz output contained in the composite signal, and the output is provided with a DC output in proportion to the amplitude of the pilot signal. This DC output is furnished through LPF-2 to the trigger amplifier which drives the stereo indicator lamp and stereo switch. Therefore, insufficient supply of the pilot signal results in failure to light the stereo indicator and to turn on the stereo switch located in the path of the 38 KHz switching signal, thereby avoiding a wrong stereo operation. H303 attached on the outside of pin 8 is a switching transistor for automatic monaural-stereo switchover. When the intensity of an incoming signal from an FM station is weaker than a predetermined level, this H303 is turned on and pin 8 is grounded, thereby developing a condition for monaural reception. For a forced monaural operation, switch the MODE switch to "MONO", and H303 comes into an "On" condition with the positive bias voltage applied to the base, and pin 8 is grounded, thereby establishing monaural operation. The transistor H302 connected externally to pin 14 is intended to stop the 76 KHz oscillation of the VCO which interferes an AM signal during the reception of an AM station. When the function switch is set to "AM" position, a positive bias is charged on the base of H302, H302 is turned on, and pin 14 is grounded. Thus, the oscillation of the VCO is stopped, ending the interference with AM reception.

3.3 Suggestion for Trouble Shooting of FM Tuner

3.3.1 Symptom: No FM Reception

First turn on the power switch and try to tune FM stations. Rotate the fly-wheel tuning knob slowly and observe the FM signal strength meter. If the signal strength meter deflects at several frequencies received, the tuner circuits preceding the discriminator circuit may have no failure. When no reading is obtained in the meter, check FM local oscillator circuit, using a RF VTVM. The normal local oscillator voltage is one or two volts (rms) at the tuning capacitor, depending on the tuning capacitor position. If the local oscillator voltage is normal, next check all voltage distribution in the FM Front End and IF amplifier unit and compare them with those shown in the circuit diagram. When signal strength meter deflects but no sound is obtained, check audio circuits, using high sensitive oscilloscope.

3.3.2 Symptom: No Stereo Separation

First check the "MONO" switch is in normal out position. Connect a FM RF signal generator output modulated by a stereo-modulator to the rear FM ANTENNA terminals, and check the stereo beacon is turned on or not. If not turned on, check for 19 KHz VCO output signal (J310), using an oscilloscope and a frequency counter.

4. PHONO AND TONE AMPLIFIERS

Signals from the PHONO jacks are applied to the phono amplifier mounted on P400. The amplified and RIAA equalized phono signals and signals from the tuner section, AUX and TAPE MONITOR IN jacks are applied to the SELECTOR switch.

All signals selected by the SELECTOR switch (S001) are let to the balance and volume controls through the MONO switch.

Signals properly attenuated by the volume control are applied to the tone amplifier and subjected to the tone control networks such as bass, mid, treble control and high and low cut filters.

Thus controlled audio signals are then led to the PRE OUT jacks on the rear panel.

5. POWER AMPLIFIER

Differential amplifier consists of the transistors H702 and H703 to provide satisfactory D.C. stability.

The transistor H707 drives the inverter transistors H714 and H715 which, in turn, drive the power stage consisting of H001 and H002. Transistors H710 and H711 are current limiter

operating as a power transistor protection circuit.

Excessive current flow in the power output stage is detected by the resistors R725 and R726 and the resultant variation is applied to the transistors H710 and H711 and make them turned on. This decreases the base biasing current for H714 and H715. In this way the current flow in the power output stage (H001 and H002) is restricted within a safe predetermined value.

6. POWER SUPPLY UNIT

The power supply unit consisting of transistors H801, H802 and H803, which operates as an automatic voltage regulator provides +35V DC to all of the audio amplifiers except power amplifiers, and H804 which operates as the voltage regulator provides +14V DC to the tuner section, and H805, H806 and H807 which operates as the speaker protector to relay circuit.

7. SPEAKER PROTECTOR RELAY CIRCUIT

The speaker protection circuit consisting of H808, H809, H810, etc protects the speaker systems against any loud "pop" sound developed. This circuit is so designed that no sound is heard for the first three or five seconds after the power switch is turned on by the time constant circuit consisting of C809 and R813. This circuit also protects the speaker systems against some troubles due to DC off balance between the speaker system terminals by instantly operating the relay and cut off the speaker systems from the circuit. When DC off balance voltage (positive) is developed between speaker terminals by possible defects such as broken power transistor, short-circuits, or broken potentiometer R707, as the base of H805 is connected to the speaker terminal, the transistor H805 is turned on by this offset voltage developed and this makes the transistor H806 and H807 turns off, thus cutting off the relay and disconnecting the speaker from the output circuit. When negative offset voltage is developed, this voltage directly turns off the H806 and H807, thus speaker is cut off from the circuit and protected.

The circuit also protects the speaker systems from the possible damage when the amplifier is over-driven by very low frequencies such as 7 or lower cycles.

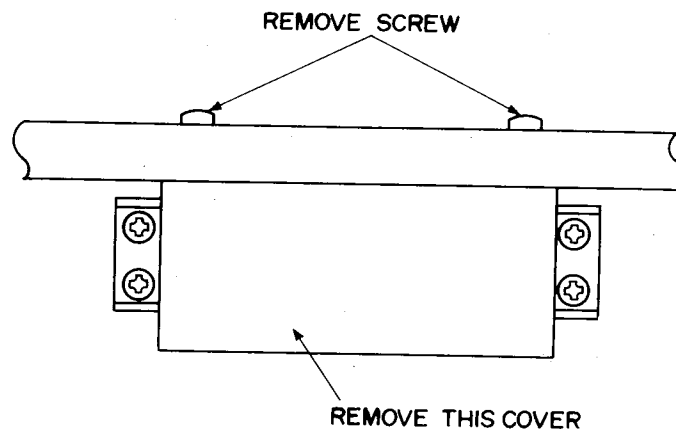

Figure 2. Remove the Terminal Cover

8. SUGGESTIONS FOR TROUBLE SHOOTING OF POWER AMPLIFIER

8.1 Excessive Line Consumption

- a. Check for shorted rectifiers H007, also check C004 and C005.
- b. Check for shorted transistors H714 and H715, H001 and H002, or check H005 and H006. Check for open control R719. Check L004 for short.

CAUTION: BECAUSE THE DRIVER AND OUTPUT STAGES ARE DIRECT COUPLED COMPONENTS MAY FAIL AS A DIRECT RESULT OF AN INITIAL COMPONENT FAILURE. IF A SHORTED TRANSISTOR OR ZENER DIODE IS FOUND, OR CONTROL OR BIAS DIODE, BE SURE TO CHECK THE REMAINING DRIVER AND OUTPUT COMPONENTS FOR SHORT OR OPEN CIRCUIT BEFORE RE-ENERGIZING THE AMPLIFIER.

8.2 No Line Consumption or Zero Bias

- a. Check line cord, fuse, transistors H001, H002, H003 and H004, bias diode H005 and H006.
- b. Check for open rectifier H007, or open L004.

8.3 No DC Balance

- a. Check R707 and Zener diodes H701 and H704.

10. TEST EQUIPMENT REQUIRED FOR SERVICING

Table 1 lists the test equipment required for servicing the Model 2240 Receiver.

Item	Manufacturer and Model No.	Use
AM Signal Generator		Signal source for AM alignment.
Test Loop		Used with AM signal generator.
FM Signal Generator	Less than 0.3% distortion	Signal source for FM alignment.
Stereo Modulator	Less than 0.3% distortion	Stereo separation alignment and trouble shooting.
Frequency Counter		MPX Oscillator adjustment (VCO).
Audio Oscillator	Weston Model CVO-100P, less than 0.02% residual distortion is required.	Sinewave and squarewave signal source.
Oscilloscope	High sensitivity with DC horizontal and vertical amplifiers.	Waveform analysis and trouble shooting and ASO alignment.
VTVM	With AC, DC, RF range	Voltage measurements.
Circuit Tester		Trouble shooting.
AC Wattmeter	Simpson, Model 390	Monitors primary power to Amplifier.
AC Ammeter	Commercial Grade (1-10A)	Monitors amplifier output under short circuit condition.
Line Voltmeter	Commercial Grade (0-150V AC)	Monitors potential of primary power to amplifier.
Variable Autotransformer (0-140V AC, 10 amps)	Powerstat, Model 116B	Adjusts level of primary power to amplifier.
Shorting Plug	Use phono plug with 600 ohm across center pin and shell.	Shorts amplifier input to eliminate noise pickup.
Output Load (8 ohms, $\pm 1\%$ 100W)	Commercial Grade	Provides 8-ohm load for amplifier output termination.
Output Load (4 ohms, $\pm 1\%$ 100W)	Commercial Grade	Provides 4-ohm load for amplifier output termination.

Table 1. Test Equipment Required for Servicing

11. AM ALIGNMENT PROCEDURE

11.1 AM IF Alignment

1. Connect a sweep generator to the J153 and an alignment scope to the test point B.
2. Rotate each core of IF transformer L153 for maximum height and flat top symmetrical response.

11.2 AM Frequency Range and Tracking Alignment

1. Set AM signal generator to 515 KHz. Turn the tuning capacitor fully closed (place the tuning pointer at the low end.) and adjust the oscillator coil L152 for maximum audio output.
2. Set the signal generator to 1650 KHz. Place the tuning pointer in the high frequency end and adjust the oscillator trimmer on the oscillator tuning capacitor for maximum audio output.
3. Repeat the step 1 and 2 until no further adjustment is necessary.
4. Set the generator to 600 KHz and tune the receiver to the same frequency and adjust a slug core of AM ferrite rod antenna and RF coil L151 for maximum output.
5. Set the generator to 1400 KHz and tune the receiver to the same frequency and adjust both trimming capacitors of antenna and RF tuned circuit for maximum output.

6. Repeat the step 4 and 5 until no further adjustment is necessary.

Note: During tracking alignment reduce the signal generator output as necessary to avoid AGC action.

11.3 AM Signal Strength Meter Alignment

Set an AM signal generator to 1000 KHz at 5 K μ V, and adjust R178 so that the signal strength meter may read 90% of the full scale.

12. AM ALIGNMENT PROCEDURE

1. Connect a FM signal generator to the FM ANTENNA terminals and a oscilloscope and an audio distortion analyzer to the TAPE OUTPUT jacks on the rear panel.
2. Set the FM SG to 87 MHz and provide about 3 to 5 μ V. Place the tuning pointer at the low frequency end by rotating the tuning knob and adjust the core of oscillator coil L104 to obtain maximum audio output.
3. Set the FM SG to 109 MHz and provide about 3 to 5 μ V output. Rotate the tuning knob and place the tuning pointer at the high frequency end and adjust the trimming capacitor C106 for maximum output.
4. Repeat the step 2 and 3 until no further adjustment is necessary.
5. Set the FM SG to 90 MHz and tune the receiver to the same frequency. Decrease signal generator output until the audio output level decreases with the decreasing generator output. Adjust the antenna coil L101, RF coil L102 and L103 and IF transformer L105 for minimum audio distortion.
6. Set the FM SG to 106 MHz and tune the receiver to the same frequency. Adjust the trimming capacitor C102, C104 and C105 for minimum distortion.
7. Repeat the step 5 and 6 until no further adjustment is necessary.
8. Adjust the secondary core (upper) of discriminator transformer L201 so that the center tuning meter pointer indicates its center at no signal applied. Set the FM SG to 98 MHz and increase its output level 1 K μ V and tune the receiver to the same frequency so that the center tuning meter pointer indicates its center.
Adjust the primary core (lower) of L201 for minimum distortion.
9. Set the FM SG to 98 MHz at 100 K μ V, and adjust R374 so that the signal strength meter may read 90% of the full scale.

13. STEREO SEPARATION ALIGNMENT

1. Set the FM SG to provide 1 K μ V at 98 MHz. Tune the receiver to the same frequency so that the center tuning meter pointer indicates its center.
2. Turn the FM SG modulation off (with the pilot signal turned off), connect a frequency counter to test point J310, and adjust R311 so that the frequency counter may precisely read 19 KHz.
3. Modulate the FM SG with stereo composite signal consisting of only subchannel signal (of course a pilot signal must be included).
4. Adjust the trimming resistor R301 for maximum and same separation in both channels.

14. MUTING CIRCUIT ALIGNMENT

1. Connect a VTVM across the resistor R363 and adjust the resistor R363 until the meter reads 0.75V DC at no signal.
2. Set the FM SG to provide 1 K μ V at 98 MHz and tune the receiver to the same frequency correctly.

3. Turn on MUTING pushswitch. Shift the FM signal generator frequency to plus and minus and note both plus and minus shifted frequencies at which undesirable audio side responses are muted out. Adjust the R363 so that the same shifted frequencies mute the undesirable side response.
4. Adjust R362 for proper frequency shift at which the muting circuit operates.

15. DOLBY FM TAPE OUTPUT SETTING

1. Set the modulation of FM SG to 400 Hz, 40% (± 30 KHz Dev.)
2. Set the FM SG to provide 1 K μ V at 98 MHz. Tune the receiver to the same frequency so that the center tuning meter pointer indicates its center.
3. Turn on DOLBY FM push switch. Set the semifixed resistors RC01 and RC02 so that the output of the TAPE OUTPUT terminals R and L become 580 mV at VT. VM.

16. AUDIO ADJUSTMENT

1. Voltage adjustment
Connect a DC voltmeter between pin terminal 804 and 805, and adjust the trimming resistor R806 for 35V DC.
2. Main Amplifier DC off-set alignment
Connect a DC voltmeter with 0.5 or 1V range between the speaker terminals and adjust the trimming resistor R707 for "zero" DC output on the meter.
Repeat the same procedure for the other channel.
Note: During this alignment no load should be connected to the speaker terminals.
3. Idle-current adjustment
Connect a VTVM between pin terminals 708 and 710. Next, adjust the trimming resistor R719 for the VTVM reads 8mV DC. Repeat the same procedure for the other channel.
4. Check DC off-set voltage aligned in the procedure 2 and if any DC output is observed on the DC voltmeter, adjust the R762 again for "zero" output.
5. Phono-amplifier adjustment
Connect a oscilloscope to the TAPE OUT jacks and an audio signal generator to the PHONO jacks. Place the selector switch in the PHONO position. Increase 1 KHz audio signal gradually until a slight clipping on top of the sine-wave is observed on the oscilloscope. Adjust the trimming resistor R708 for equal clipping level.
For the other channel adjust R709.

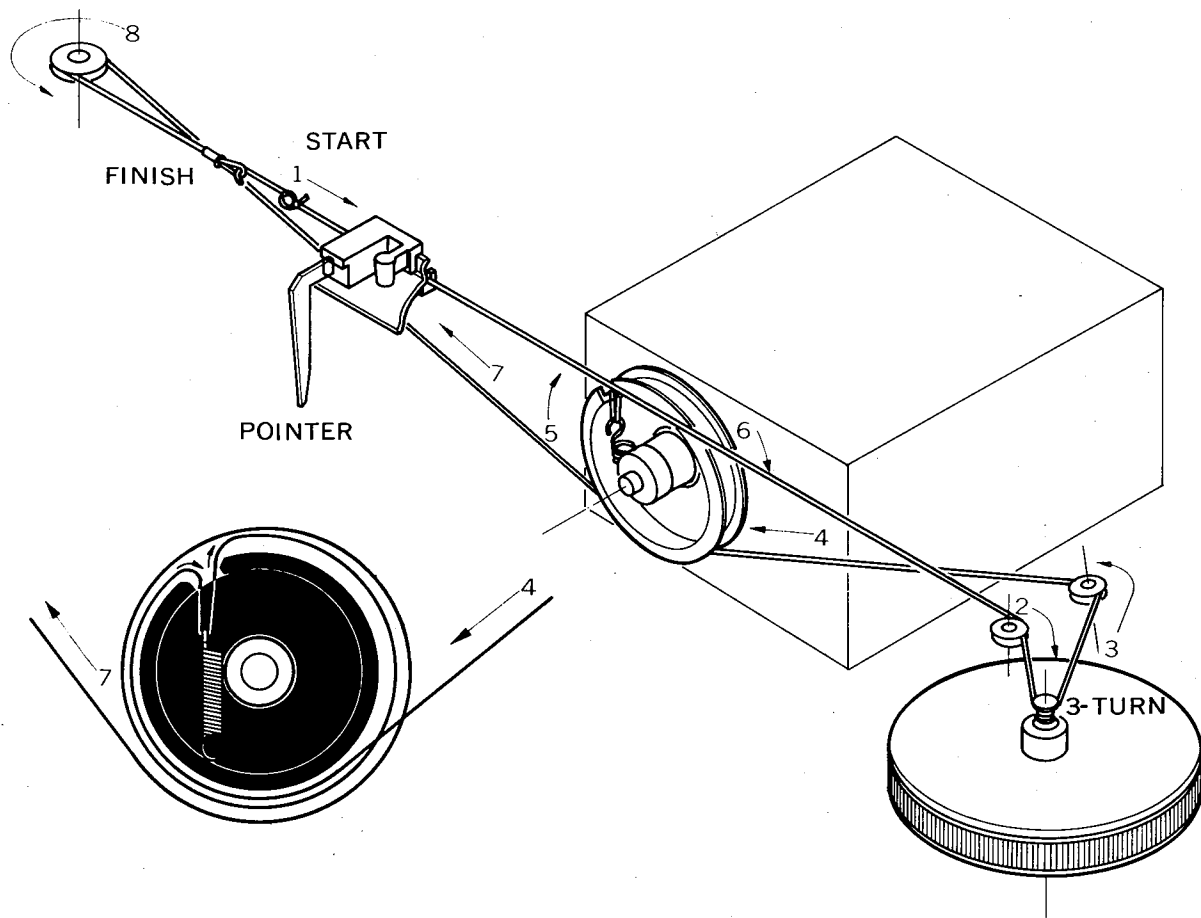

Figure 3. Dial Stringing

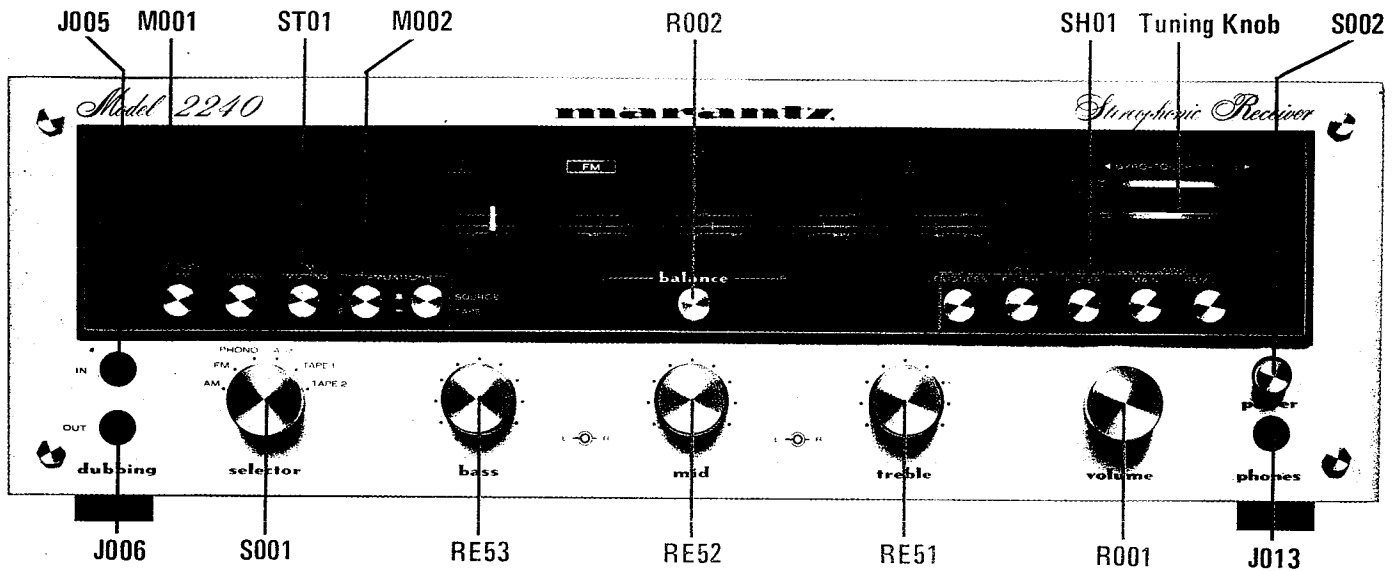

Figure 4. Front Panel Adjustment and Component Locations

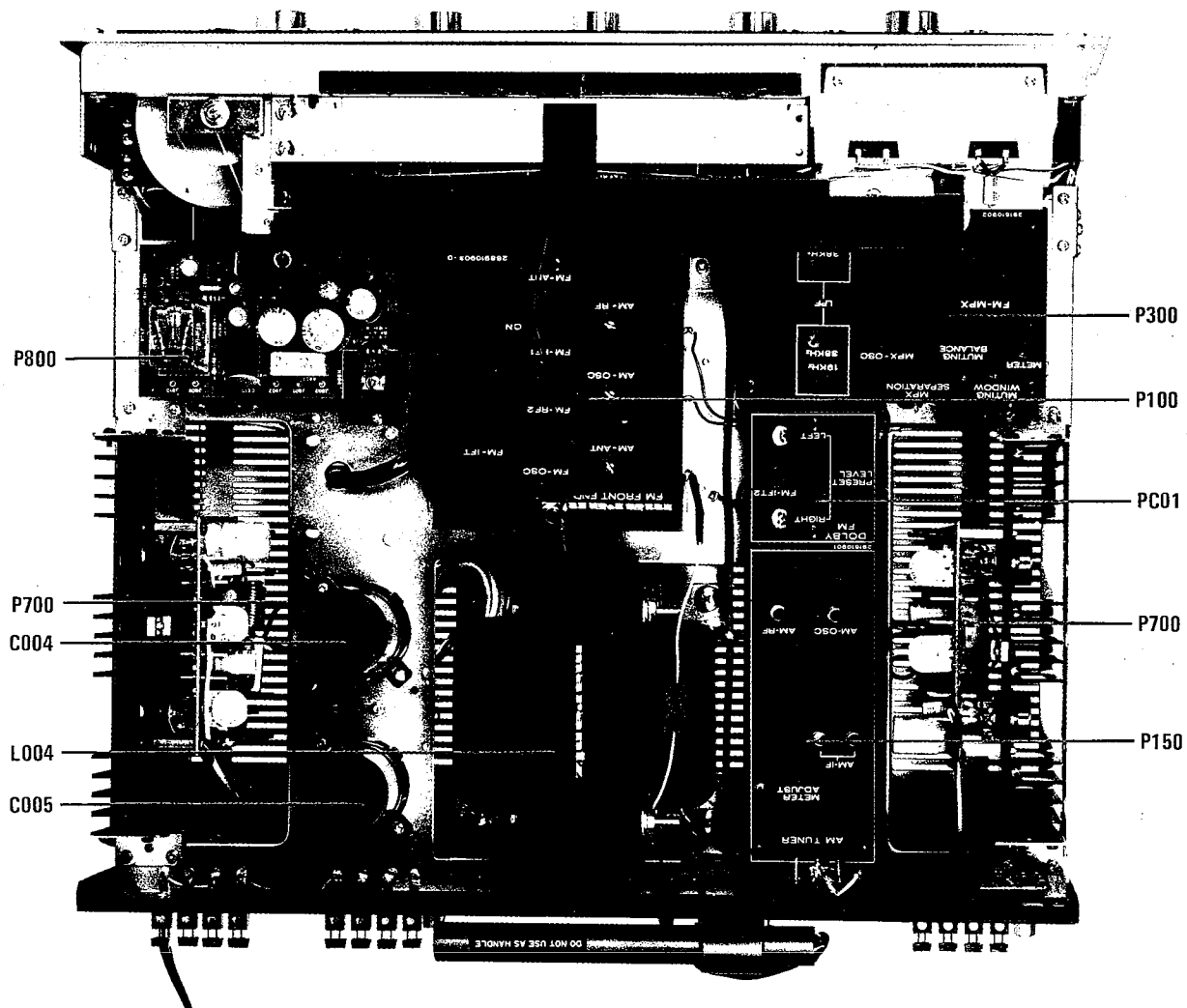

Figure 5. Main Chassis Component Locations (Top View)

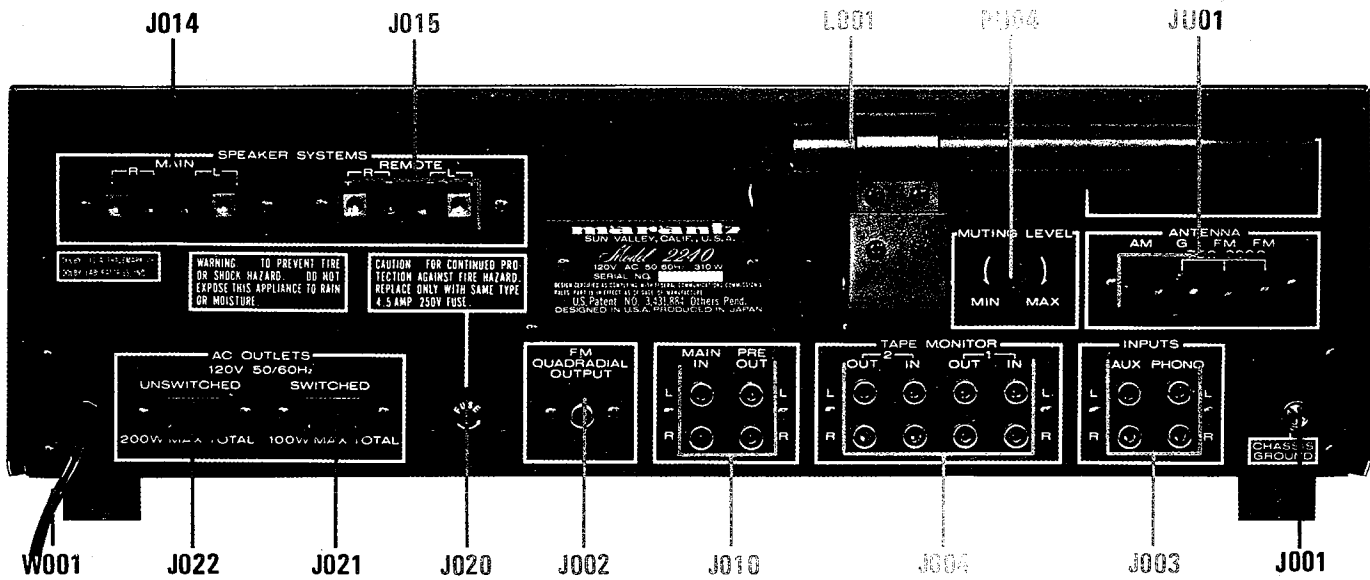

Figure 6. Rear Panel Adjustment and Component Locations

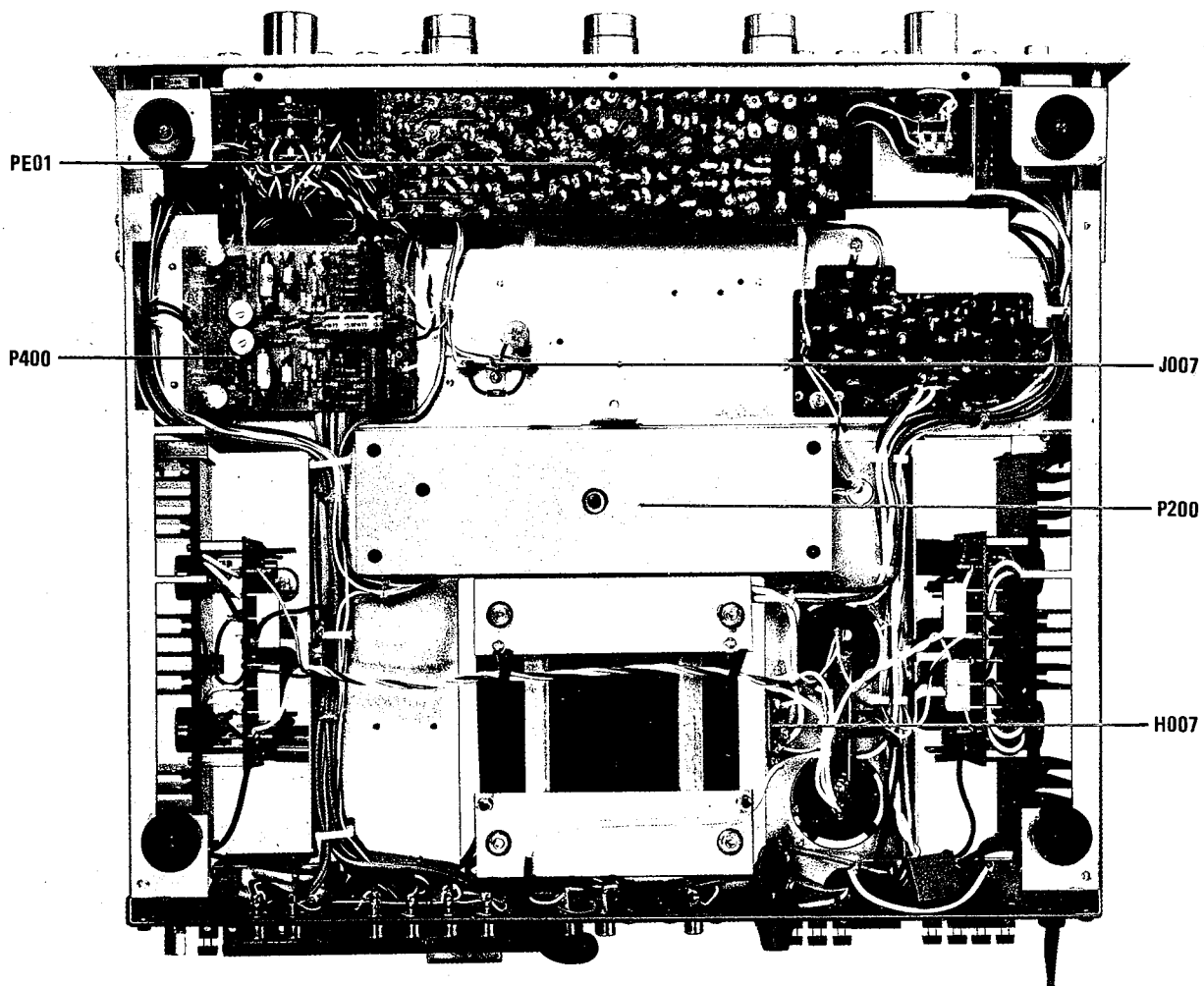

Figure 7. Main Chassis Component Locations (Bottom View)

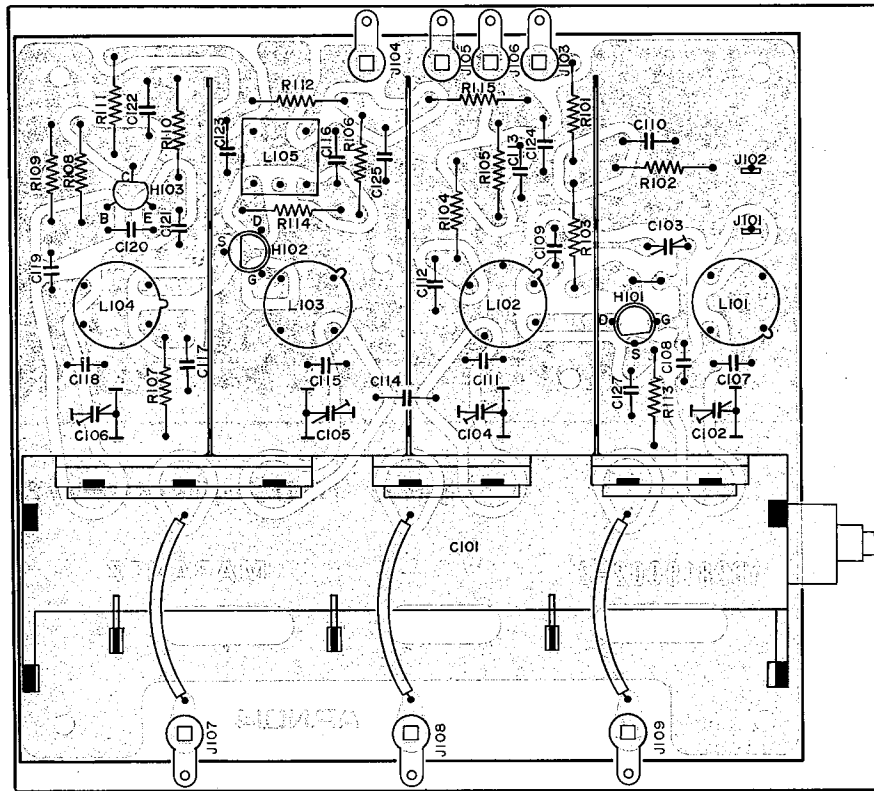

Figure 8. FM Front End Assembly P100 Component Locations

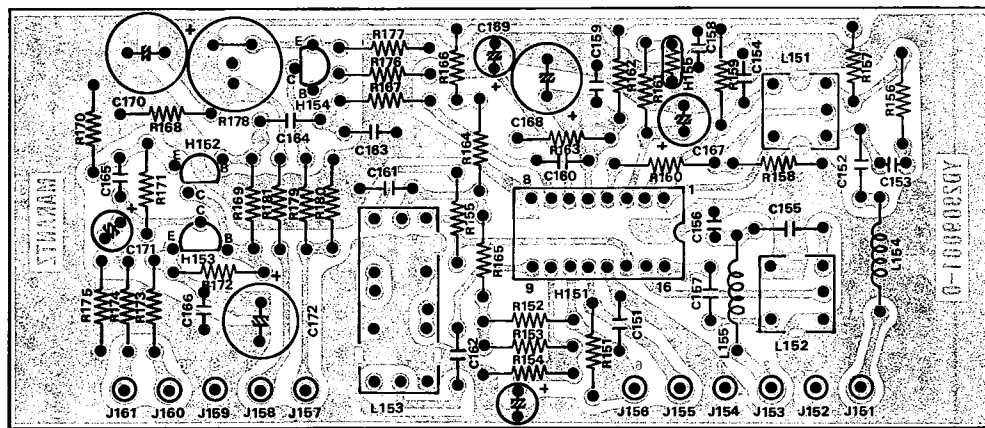

Figure 9. AM Tuner Unit Assembly P150 Component Locations

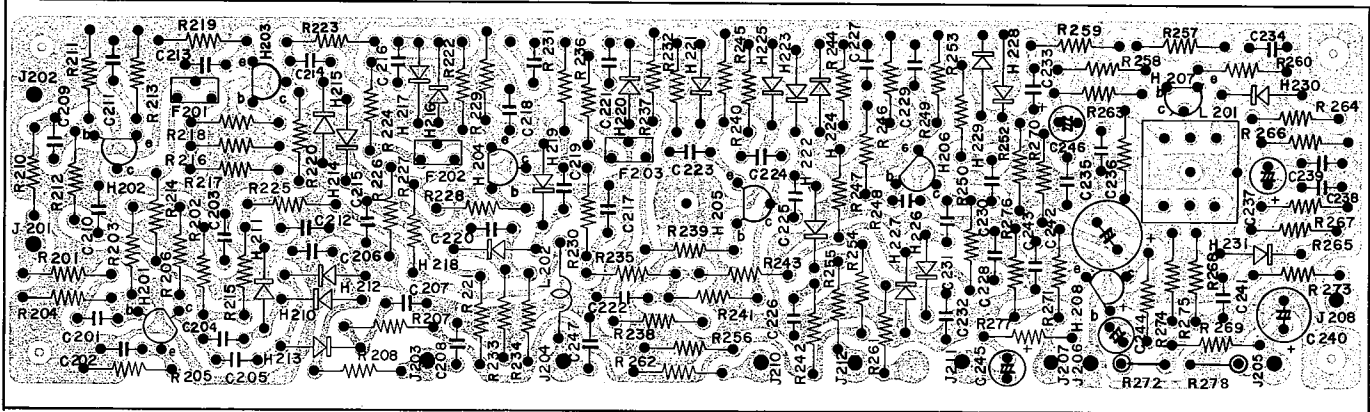

Figure 10. FM 1F Amplifier Assembly P200 Component Locations

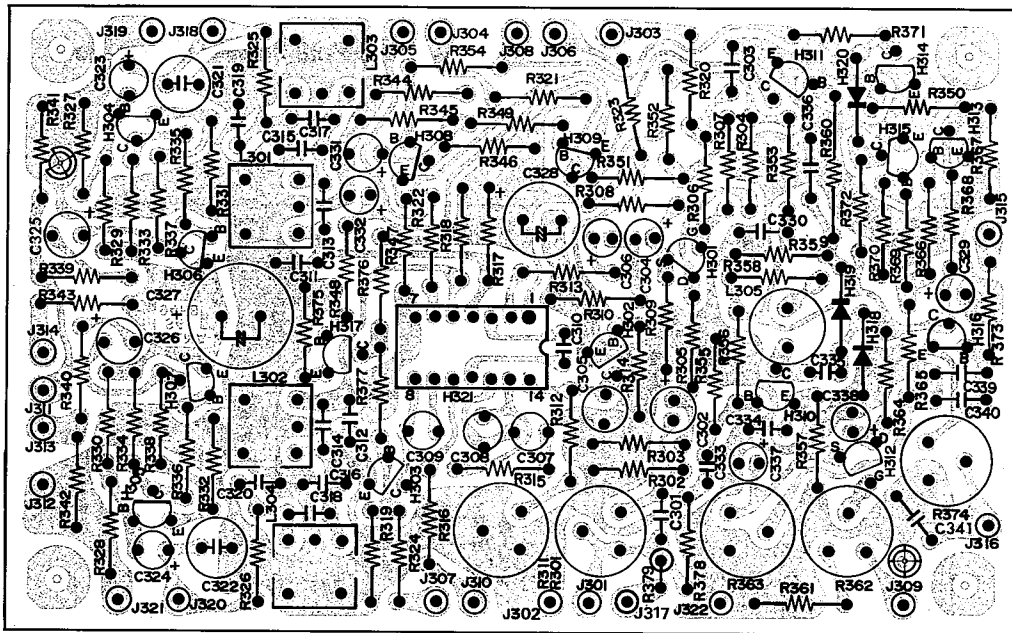

Figure 11. MPX Stereo Decoding Amplifier Assembly P300 Component Locations

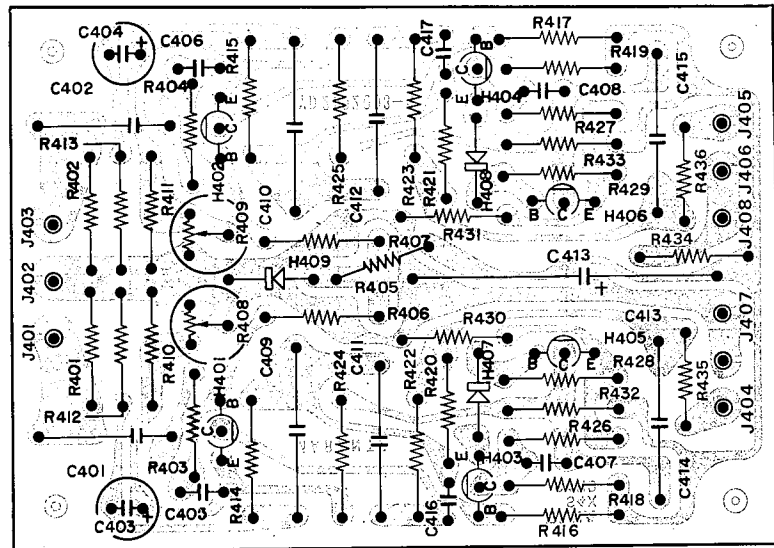

Figure 12. Phono Amplifier Assembly P400 Component Locations

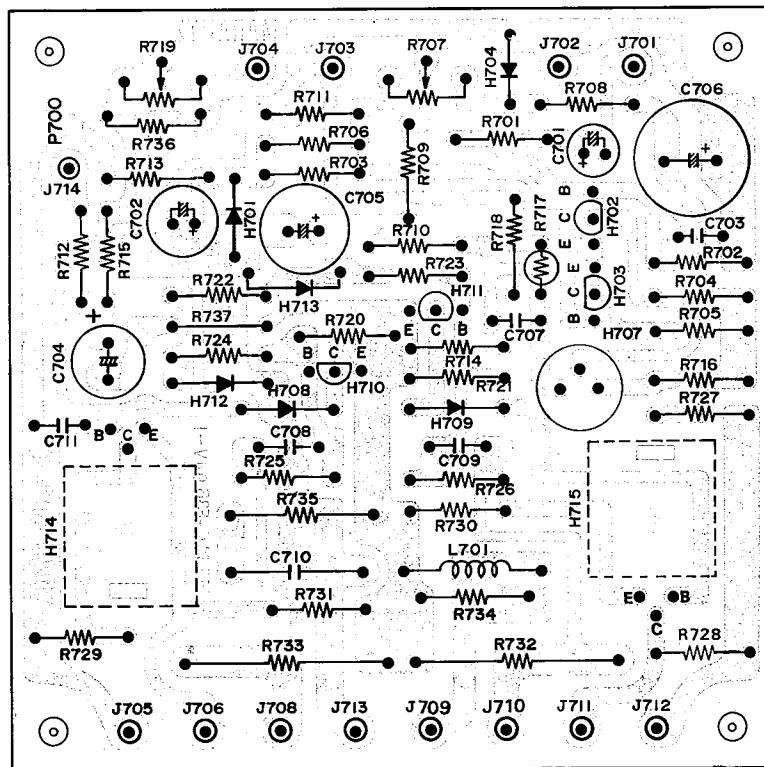

Figure 13. Power Amplifier Assembly P700 Component Locations

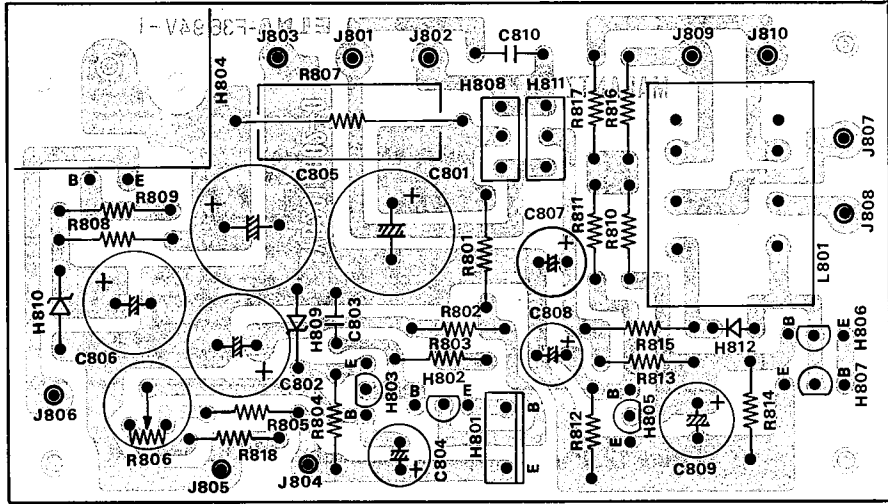

Figure 14. Power Supply Assembly P800 Component Locations

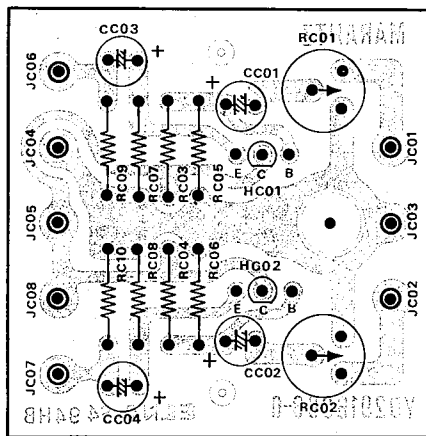

Figure 15. Dolby Level Assembly PC01 Component Locations

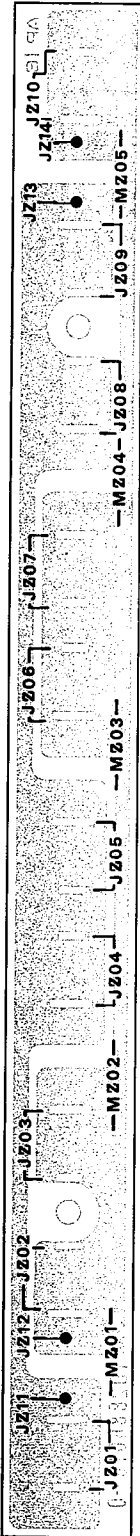

Figure 16. Dial Lamp Assembly PZ01 Component Locations

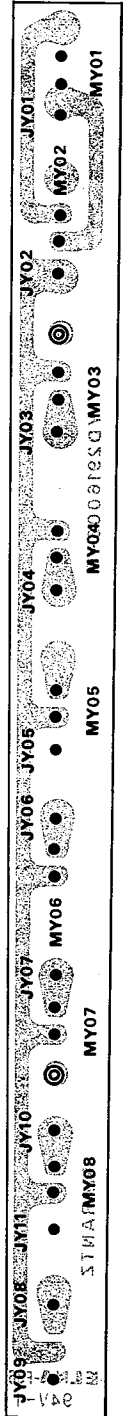

Figure 17. Functions Lamp Assembly PY01 Component Locations

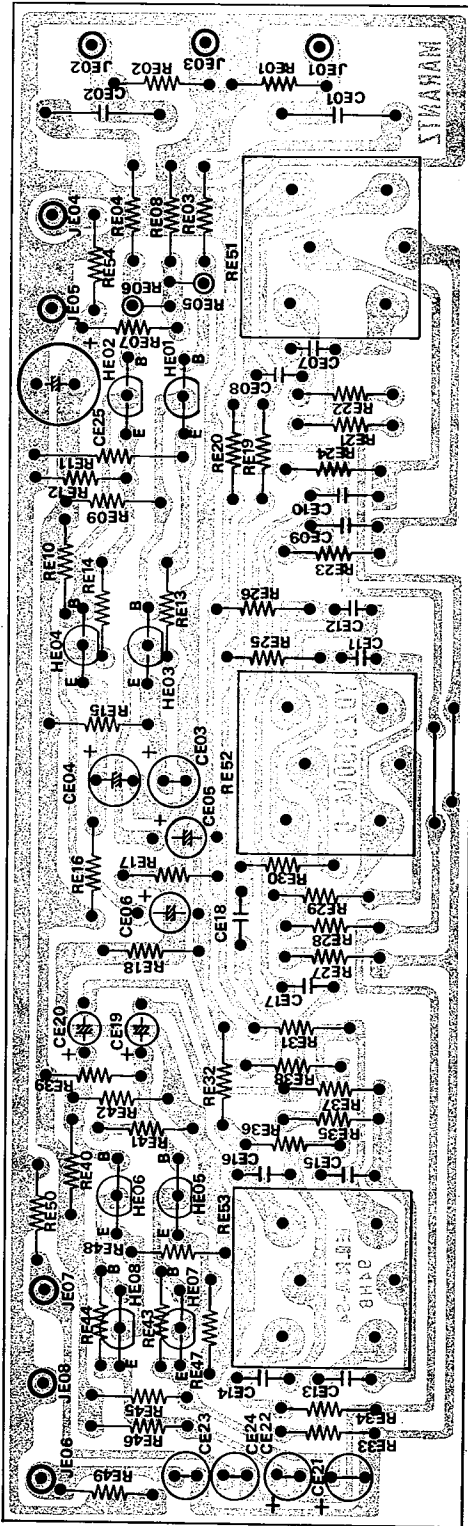

Figure 18. Pre-Tone Amplifier Assembly PE01 Component Locations

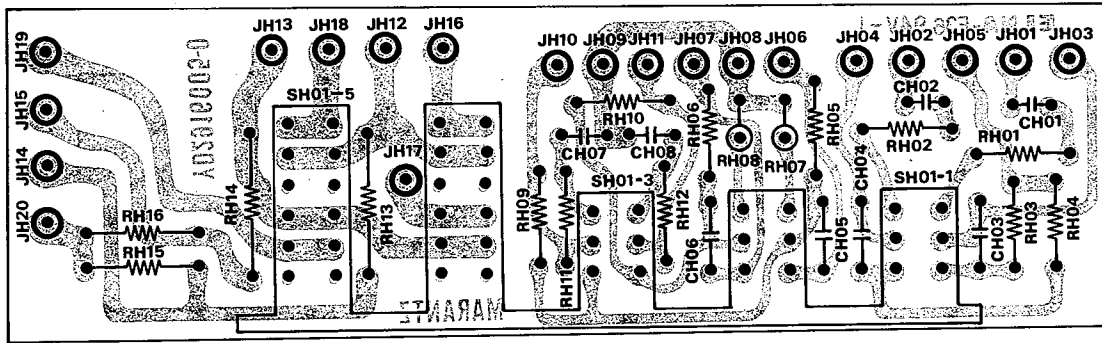

Figure 19. High and Low Filter and Muting Switch Unit Assembly PH01 Component Locations

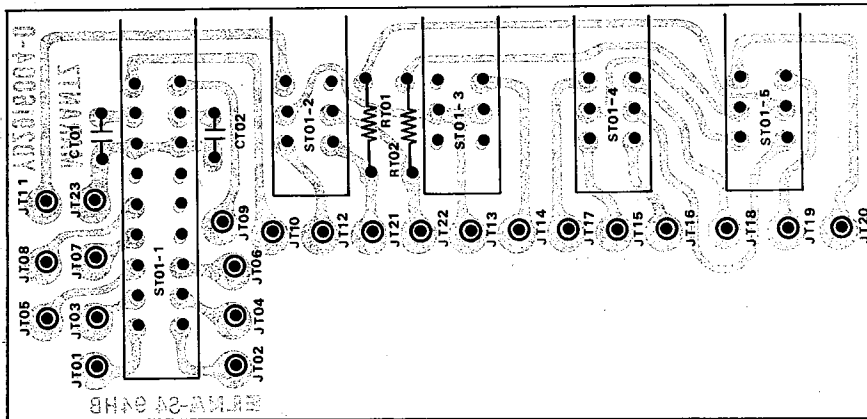

Figure 20. Monitor Dolby Assembly PT01 Component Locations

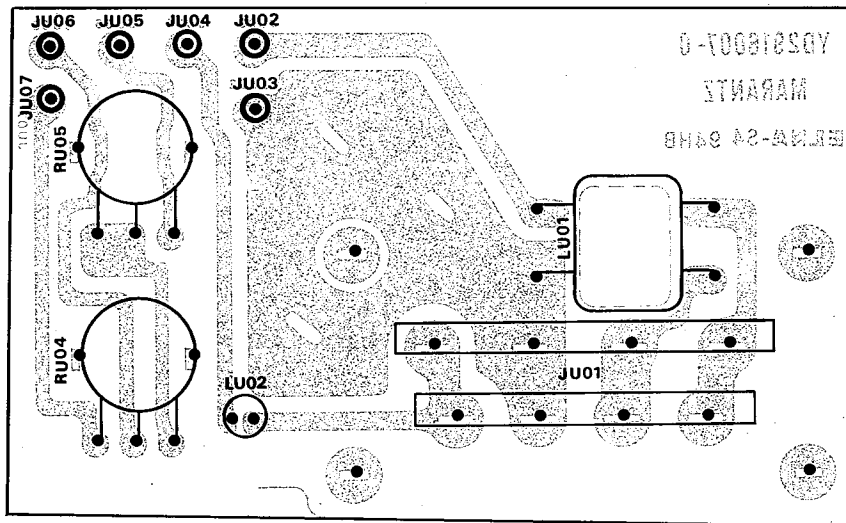

Figure 21. ANT. Muting Assembly PU01 Component Locations

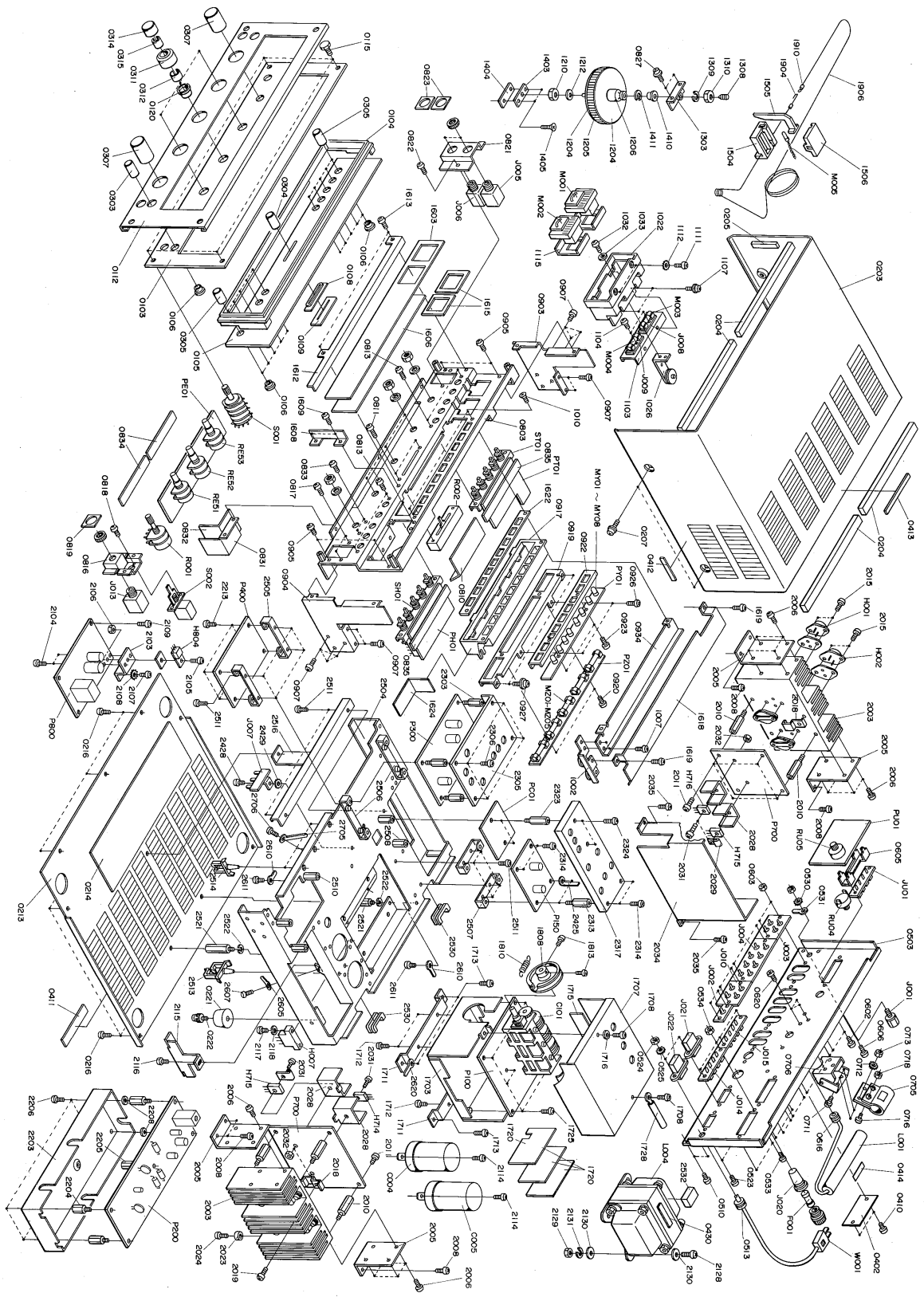

Figure 22. Exploded Mechanical Diagram

Parts List

U: For U.S.A.
E: For Europe

REF. DESIG.	U	E	PART NO.	DESCRIPTION
A	1	1	291606340	Front Panel Assembly
0103	1	1	291606301	Escutcheon
0104	1	1	285340101	Frame
0105	1	1	291615801	Window
0106	1	1	288625901	Bush
0108	1	1	285425901	Bush
0109	1	1	291510701	Sheet
0112	1	1	291605301	Cover
B	3	3	281815440	Knob Assembly
0311	3	3	281815404	Knob
0312	3	3	71400149Q	Spring
C	3	3	281815441	Knob Assembly
0314	3	3	281815405	Knob
0315	3	3	71400159Q	Spring
D	1	1	285327340	Fly Wheel Assembly
1204	2	2	257706302	Escutcheon
1205	1	1	257727301	Fly Wheel
1206	1	1	285311201	Shaft
1210	1	1	53110603E	Hexagon Nut
1212	1	1	54020601E	Flat Washer
E	1	1	120200640	Hook Assembly
1904	1	1	120225801	Hook
1906	1	1	72080802A	String
F	1	1	291510340	Pointer Assembly
1504	1	1	291510301	Pointer
1505	1	1	281810302	Pointer
1506	1	1	291510302	Cover
M005	1	1	IN1008030	Lamp
G	1	1	281915940	Drum Assembly
1808	1	1	281915901	Drum
1810	1	1	71101569M	Spring
1813	2	2	51650304D	Set Screw
P100 FM FRONT END BOARD				
P100	1	1	YD2819002	PW Board FM Front End
	1	1	ZZ2916102	PW Board Assembly
P100 RESISTORS				
R101	1	1	RT0556314	Resistor 56KΩ ±5% ¼W
R102	1	1	RT0510514	Resistor 1MΩ ±5% ¼W
R103	1	1	RT0510414	Resistor 100KΩ ±5% ¼W
R104	1	1	RT0522114	Resistor 220Ω ±5% ¼W
R105	1	1	RT0522114	Resistor 220Ω ±5% ¼W
R106	1	1	RT0510214	Resistor 1KΩ ±5% ¼W
R107	1	1	RT0547214	Resistor 4.7KΩ ±5% ¼W
R108	1	1	RT0522314	Resistor 22KΩ ±5% ¼W
R109	1	1	RT0522314	Resistor 22KΩ ±5% ¼W
R110	1	1	RT0512214	Resistor 1.2KΩ ±5% ¼W
R111	1	1	RT0510114	Resistor 100Ω 5% ¼W
R112	1	1	RT0510114	Resistor 100Ω 5% ¼W
R113	1	1	RT0510114	Resistor 100Ω 5% ¼W
R114	1	1	RT0522314	Resistor 22KΩ 5% ¼W
R115	1	1	RT0510114	Resistor 100Ω 5% ¼W
P100 CAPACITORS				
C101	1	1	CA4330001	Variable Cap
C102	1	1	CT1100001	Trimming Cap 1.5 10PF
C103	1	1	CT1100002	Trimming Cap 1.5 10PF
C104	1	1	CT1100001	Trimming Cap 1.5 10PF
C105	1	1	CT1100001	Trimming Cap 1.5 10PF
C106	1	1	CT1100001	Trimming Cap 1.5 10PF

REF. DESIG.	U	E	PART NO.	DESCRIPTION
C107	1	1	DD1615001	Ceramic Cap 15PF ±10%
C108	1	1	DK1710201	Ceramic Cap 1000PF ±20%
C109	1	1	DD1105001	Ceramic Cap 5PF ±0.5PF
C110	1	1	DK1710201	Ceramic Cap 1000PF ±20%
C111	1	1	DD1615001	Ceramic Cap 15PF ±10%
C112	1	1	DK1710201	Ceramic Cap 1000PF ±20%
C113	1	1	DK1710301	Ceramic Cap 0.01μF ±20%
C114	1	1	DD1001001	Ceramic Cap 1.0PF ±0.25PF
C115	1	1	DD1615001	Ceramic Cap 15PF ±10%
C116	1	1	DK1710301	Ceramic Cap 0.01μF ±20%
C117	1	1	DK1710301	Ceramic Cap 0.01μF ±20%
C118	1	1	DD1620003	Ceramic Cap 20PF ±10%
C119	1	1	DD1210006	Ceramic Cap 10PF ±1PF
C120	1	1	DD1615003	Ceramic Cap 15PF ±10%
C121	1	1	DD1615003	Ceramic Cap 15PF ±10%
C122	1	1	DK1710301	Ceramic Cap 0.01μF ±20%
C123	1	1	DK1710301	Ceramic Cap 0.01μF ±20%
C124	1	1	DK1710301	Ceramic Cap 0.01μF ±20%
C125	1	1	DK1710301	Ceramic Cap 0.01μF ±20%
C127	1	1	DK1710301	Ceramic Cap 0.01μF ±20%
P100 COILS & TRANSFORMER				
L101	1	1	LA1202603	ANT Coil
L101	1	1	LA1203601	ANT Coil
L102	1	1	LA1202604	RF Coil
L103	1	1	LA1202605	RF Coil
L103	1	1	LA1202609	RF Coil
L104	1	1	LO1202608	OSC Coil
L105	1	1	LI1001601	I F T
P100 SEMICONDUCTORS				
H101	1	1	HF200191A	Transistor 2SK19Y
H102	1	1	HF200191A	Transistor 2SK19Y
H103	1	1	HT305351B	Transistor 2SC535B
J101	~	2	YP1000094	Plug
J102				
J103	1	1	57271240W	Lug Eyelet
J104	1	1	57271240W	Lug Eyelet
J105	1	1	57271240W	Lug Eyelet
J106	1	1	57271240W	Lug Eyelet
J107	1	1	57271240W	Lug Eyelet
J108	1	1	57271240W	Lug Eyelet
J109	1	1	57221240W	Lug Eyelet
1720	3	3	273010903	Shield
1725	5	5	51100306S	B H M Screw B 3 x 6
1703	1	1	273010950	Shield K
1711	2	2	281916008	Bracket
1712	4	4	51100306A	B H M Screw B 3 x 6
1722	1	1	341105605	Buffer
P150 AM TUNER BOARD				
P150	1	1	YD2909001	P W Board AM Tuner
	1	1	ZZ2916101	P W Board Assembly
		1	ZZ2916801	P W Board Assembly
P150 RESISTORS				
R151	1	1	RT0510314	Resistor 10K Ω ±5% ¼W
R152	1	1	RT0530314	Resistor 30K Ω ±5% ¼W
R153	1	1	RT0582314	Resistor 82K Ω ±5% ¼W
R154	1	1	RT0522314	Resistor 22K Ω ±5% ¼W
R155	1	1	RT0522414	Resistor 220K Ω ±5% ¼W

REF. DESIG.	U	E	PART NO.	DESCRIPTION
R156	1	1	RT0510414	Resistor 100KΩ ±5% ¼W
R157	1	1	RC0000014	Resistor 0Ω ±5% ¼W
R158	1	1	RT0539314	Resistor 39KΩ ±5% ¼W
R159	1	1	RT0539214	Resistor 3.9KΩ ±5% ¼W
R160	1	1	RC0000012	Resistor 0Ω ±5% ¼W
R161	1	1	RT0543214	Resistor 4.3KΩ ±5% ¼W
R162	1	1	RT0510114	Resistor 100Ω ±5% ¼W
R163	1	1	RT0515214	Resistor 1.5KΩ ±5% ¼W
R164	1	1	RT0533114	Resistor 330Ω ±5% ¼W
R165	1	1	RC0000014	Resistor 0Ω ±5% ¼W
R166	1	1	RC0000014	Resistor 0Ω ±5% ¼W
R167	1	1	RT0522214	Resistor 2.2KΩ ±5% ¼W
R168	1	1	RT0582314	Resistor 82KΩ ±5% ¼W
R169	1	1	RT0562414	Resistor 620KΩ ±5% ¼W
R170	1	1	RT0551114	Resistor 510Ω ±5% ¼W
R171	1	1	RT0522214	Resistor 2.2KΩ ±5% ¼W
R172	1	1	RT0556214	Resistor 5.6KΩ ±5% ¼W
R173	1	1	RT0510214	Resistor 1KΩ ±5% ¼W
R174	1	1	RT0510114	Resistor 100Ω ±5% ¼W
R175	1	1	RT0510414	Resistor 100KΩ ±5% ¼W
R176	1	1	RT0510314	Resistor 10KΩ ±5% ¼W
R177	1	1	RT0512314	Resistor 12KΩ ±5% ¼W
R178	1	1	RA0103025	Trimming Resist 10KΩ B
R179	1	1	RT0510314	Resistor 10KΩ ±5% ¼W
R180	1	1	RT0515214	Resistor 1.5KΩ ±5% ¼W
R181	1	1	RT0510114	Resistor 100Ω ±5% ¼W
R182	1	1	RT0515214	Resistor 1.5KΩ ±5% ¼W
P150 CAPACITORS				
C151	1	1	DK1710301	Ceramic Cap .01μF ±20%
C152	1	1	DF1747305	Film Cap .047μF ±20%
C154	1	1	DK1710301	Film Cap .01μF ±20%
C155	1	1	DF6545101	Film Cap 450PF ±5%
C156	1	1	DD1615001	Ceramic Cap 15PF ±10%
C157	1	1	DK1710301	Ceramic Cap .01μF ±20%
C158	1	1	DK1840302	Ceramic Cap .04μF ±20%
C159	1	1	DK1840302	Ceramic Cap .04μF ±20%
C160	1	1	DK1710301	Ceramic Cap .01μF ±20%
C161	1	1	DK1710301	Ceramic Cap .01μF ±20%
C162	1	1	DK1710301	Ceramic Cap .01μF ±20%
C163	1	1	DF1615305	Film Cap .015μF 10%
C164	1	1	DF1627305	Film Cap .027μF ±10%
C165	1	1	DF1756205	Film Cap 5600PF ±20%
C166	1	1	DK1840302	Film Cap .04μF ±20%
C167	1	1	EA2260169	Electroly Cap 22μF 16V
C168	1	1	EA1070169	Electroly Cap 100μF 16V
C169	1	1	EA4750359	Electroly Cap 4.7μF 35V
C170	1	1	EA1070169	Electroly Cap 100μF 16V
C171	1	1	EA1050509	Electroly Cap 1μF 50V
C172	1	1	EA1070169	Electroly Cap 100μF 16V
C173	1	1	EA4750359	Electroly Cap 4.7μF 35V
P150 SEMICONDUCTORS				
H151	1	1	HC1000506	IC
H152	1	1	HT313272A	Transistor
H153	1	1	HT104942A	Transistor
H154	1	1	HT104942A	Transistor
H155	1	1	HH0000212	Thermistor
P150 COILS & TRANSFORMERS				
L151	1	1	LA1001019	RF Coil
L152	1	1	LO1001050	OSC Coil
L153	1	1	LI1028002	I F T
L154	1	1	LC1332002	Choke Coil

REF. DESIG.	U	E	PART NO.	DESCRIPTION
L155	1	1	LC1332002	Choke Coil
L153	1	1	LI1028003	I F T
P150 PLUGS				
J151	~	9	YP1000113	Plug
J161	9	9		
P200 FM IF BOARD				
All resistors are ¼W, unless otherwise indicated				
P200	1	1	YD2884006	P W Board
	1	1	ZZ2916106	P W Board Assembly
P200 RESISTORS				
R201	1	1	RT0533014	Resistor 33Ω ±10%
R202	1	1	RT0510114	Resistor 100Ω ±10%
R203	1	1	RT0512314	Resistor 12KΩ ±10%
R204	1	1	RT0547214	Resistor 4.7KΩ ±10%
R205	1	1	RT0510214	Resistor 1KΩ ±10%
R206	1	1	RT0522214	Resistor 2.2KΩ ±10%
R207	1	1	RT0510314	Resistor 10KΩ ±10%
R208	1	1	RT0533314	Resistor 33KΩ ±10%
R210	1	1	RT0533014	Resistor 33Ω ±10%
R211	1	1	RT0515214	Resistor 1.5KΩ ±10%
R212	1	1	RT0533214	Resistor 3.3KΩ ±10%
R213	1	1	RT0547114	Resistor 470Ω ±10%
R214	1	1	RT0510214	Resistor 1KΩ ±10%
R215	1	1	RT0510114	Resistor 100Ω ±10%
R216	1	1	RT0515214	Resistor 1.5KΩ ±10%
R217	1	1	RT0533214	Resistor 3.3KΩ ±10%
R218	1	1	RT0515114	Resistor 150Ω ±10%
R219	1	1	RT0510214	Resistor 1KΩ ±10%
R220	1	1	RT0510214	Resistor 1KΩ ±10%
R221	1	1	RT0518314	Resistor 18KΩ ±10%
R222	1	1	RT0510414	Resistor 100KΩ ±10%
R223	1	1	RT0575014	Resistor 75Ω ±10%
R224	1	1	RT0527114	Resistor 270Ω ±10%
R225	1	1	RT0515114	Resistor 150Ω ±10%
R226	1	1	RT0582114	Resistor 820Ω ±10%
R227	1	1	RT0533214	Resistor 3.3KΩ ±10%
R228	1	1	RT0515114	Resistor 150Ω ±10%
R229	1	1	RT0510214	Resistor 1KΩ ±10%
R230	1	1	RT0510214	Resistor 1KΩ ±10%
R231	1	1	RT0515114	Resistor 150Ω ±10%
R232	1	1	RT0510414	Resistor 100KΩ ±10%
R233	1	1	RT0527314	Resistor 27KΩ ±10%
R234	1	1	RT0522314	Resistor 22KΩ ±5%
R235	1	1	RT0510114	Resistor 100Ω ±5%
R236	1	1	RT0513114	Resistor 130Ω ±5%
R237	1	1	RT0582214	Resistor 8.2KΩ ±5%
R238	1	1	RT0510414	Resistor 100KΩ ±5%
R239	1	1	RT0515114	Resistor 150KΩ ±5%
R240	1	1	RT0510214	Resistor 1KΩ ±5%
R241	1	1	RT0510214	Resistor 1KΩ ±5%
R242	1	1	RT0568314	Resistor 68KΩ ±5%
R243	1	1	RT0510114	Resistor 100Ω ±5%
R244	1	1	RT0510414	Resistor 100KΩ ±5%
R245	1	1	RT0527114	Resistor 270Ω ±5%
R246	1	1	RT0582214	Resistor 8.2KΩ ±5%
R247	1	1	RT0515314	Resistor 15KΩ ±5%
R248	1	1	RT0515114	Resistor 150Ω ±5%
R249	1	1	RT0510214	Resistor 1KΩ ±5%
R250	1	1	RT0510214	Resistor 1KΩ ±5%
R252	1	1	RT0510414	Resistor 100KΩ ±5%

U: For U.S.A.
E: For Europe

REF. DESIG.	U	E	PART NO.	DESCRIPTION
R253	1	1	RT0515114	Resistor 150Ω ±5%
R254	1	1	RT0515314	Resistor 15KΩ ±5%
R256	1	1	RT0512314	Resistor 12KΩ ±5%
R257	1	1	RT0582214	Resistor 8.2KΩ ±5%
R258	1	1	RT0515314	Resistor 15KΩ ±5%
R259	1	1	RT0515114	Resistor 150Ω ±5%
R260	1	1	RT0510214	Resistor 1KΩ ±5%
R261	1	1	RT0522314	Resistor 22KΩ ±5%
R262	1	1	RT0522314	Resistor 22KΩ ±5%
R263	1	1	RT0522114	Resistor 220Ω ±5%
R264	1	1	RT0582114	Resistor 820Ω ±5%
R265	1	1	RT0582114	Resistor 820Ω ±5%
R266	1	1	RT0510314	Resistor 10KΩ ±5%
R267	1	1	RT0510314	Resistor 10KΩ ±5%
R268	1	1	RT0510114	Resistor 100Ω ±5%
R269	1	1	RT0515314	Resistor 15KΩ ±5%
R270	1	1	RT0510114	Resistor 100Ω ±5%
R271	1	1	RT0510114	Resistor 100Ω ±5%
R272	1	1	RT0556214	Resistor 5.6KΩ ±5%
R273	1	1	RT0510414	Resistor 100KΩ ±5%
R274	1	1	RT0518414	Resistor 180KΩ ±5%
R275	1	1	RT0510414	Resistor 100KΩ ±5%
R276	1	1	RT0522214	Resistor 2.2KΩ ±5%
R277	1	1	RT0510114	Resistor 100Ω ±5%
R278	1	1	RT0522214	Resistor 2.2KΩ ±5%
P200 CAPACITORS				
C201	1	1	DK1710301	Ceramic Cap .01μF ±20%
C202	1	1	DK1710301	Ceramic Cap .01μF ±20%
C203	1	1	DK1840302	Ceramic Cap .04μF ±20%
C204	1	1	DK1710301	Ceramic Cap .01μF ±20%
C205	1	1	DD1620101	Ceramic Cap 200PF ±10%
C206	1	1	DK1710301	Ceramic Cap .01μF ±20%
C207	1	1	DK1710301	Ceramic Cap .01μF ±20%
C208	1	1	DK1810402	Ceramic Cap .1μF ±20%
C209	1	1	DK1710301	Ceramic Cap .01μF ±20%
C210	1	1	DK1840302	Ceramic Cap .04μF ±20%
C211	1	1	DK1840302	Ceramic Cap .04μF ±20%
C212	1	1	DK1840302	Ceramic Cap .04μF ±20%
C213	1	1	DK1710301	Ceramic Cap .01μF ±20%
C214	1	1	DD1620101	Ceramic Cap 200PF ±10%
C215	1	1	DK1710301	Ceramic Cap .01μF ±20%
C216	1	1	DK1710301	Ceramic Cap .01μF ±20%
C217	1	1	DK1840302	Ceramic Cap .04μF ±20%
C218	1	1	DK1710301	Ceramic Cap .01μF ±20%
C219	1	1	DD1620101	Ceramic Cap 200PF ±10%
C220	1	1	DK1710301	Ceramic Cap .01μF ±20%
C221	1	1	DK1710301	Ceramic Cap .01μF ±20%
C222	1	1	DK1840302	Ceramic Cap .04μF ±20%
C223	1	1	DK1710301	Ceramic Cap .01μF ±20%
C224	1	1	DK1710301	Ceramic Cap .01μF ±20%
C225	1	1	DD1620101	Ceramic Cap 200PF ±10%
C226	1	1	DK1710301	Ceramic Cap .01μF ±20%
C227	1	1	DK1710301	Ceramic Cap .01μF ±20%
C228	1	1	DK1840301	Ceramic Cap .04μF ±20%
C229	1	1	DK1710301	Ceramic Cap .01μF ±20%
C230	1	1	DK1710301	Ceramic Cap .01μF ±20%
C231	1	1	DK1710201	Ceramic Cap .001μF ±20%
C232	1	1	DK1810402	Ceramic Cap .1μF ±20%
C233	1	1	DK1710301	Ceramic Cap .01μF ±20%
C234	1	1	DK1710301	Ceramic Cap .01μF ±20%
C235	1	1	DK1840302	Ceramic Cap .04μF ±20%
C236	1	1	DK1710301	Ceramic Cap .01μF ±20%
C237	1	1	EA1060169	Electroly Cap 10μF 16V

REF. DESIG.	U	E	PART NO.	DESCRIPTION
C238	1	1	DD1620101	Ceramic Cap 200PF ±20%
C239	1	1	DD1620101	Ceramic Cap 200PF ±20%
C240	1	1	EA1070109	Electroly Cap 100μF 10V
C241	1	1	DD1620101	Ceramic Cap 200PF ±20%
C242	1	1	EA1070169	Electroly Cap 100μF 16V
C243	1	1	DK1840302	Ceramic Cap .04μF ±20%
C244	1	1	EA1060169	Electroly Cap 10μF 16V
C245	1	1	EA2260169	Electroly Cap 22μF 16V
C246	1	1	EA1060169	Electroly Cap 22μF 16V
C247	1	1	DK1710301	Ceramic Cap .01μF ±20%
C248	1	1	DD1540001	Ceramic Cap 40PF ±5%
C249	1	1	DK1840302	Ceramic Cap .04μF ±20%
F201	1	1	FF1107004	Ceramic Filter CFS107M
F202	1	1	FF1107004	Ceramic Filter CFS107M
F203	1	1	FF1107004	Ceramic Filter CFS107M
P200 SEMICONDUCTOR				
H201	1	1	HT308291C	Transistor 2SC829C
H202	1	1	HT308291C	Transistor 2SC829C
H203	1	1	HT308291C	Transistor 2SC829C
H204	1	1	HT308291C	Transistor 2SC829C
H205	1	1	HT308291C	Transistor 2SC829C
H206	1	1	HT308291C	Transistor 2SC829C
H207	1	1	HT308291C	Transistor 2SC829C
H208	1	1	HT306441B	Transistor 2SC6445
H210	1	1	HD1000105	Diode IN60
H211	1	1	HD1000105	Diode IN60
H212	1	1	HD1000105	Diode IN60
H213	1	1	HD1000105	Diode IN60
H214	1	1	HD1000105	Diode IN60
H215	1	1	HD1000105	Diode IN60
H216	1	1	HD2001105	Diode 1S1555
H217	1	1	HD2001105	Diode 1S1555
H218	1	1	HD1000105	Diode IN60
H219	1	1	HD1000105	Diode IN60
H220	1	1	HD2001105	Diode 1S1555
H221	1	1	HD2001105	Diode 1S1555
H222	1	1	HD1000105	Diode IN60
H223	1	1	HD1000105	Diode IN60
H224	1	1	HD2001105	Diode 1S1555
H225	1	1	HD2001105	Diode 1S1555
H226	1	1	HD1000105	Diode IN60
H227	1	1	HD1000105	Diode IN60
H228	1	1	HD2001105	Diode 1S1555
H229	1	1	HD2001105	Diode 1S1555
H230	1	1	HD1000302	Diode 20A90M
H231	1	1	HD1000302	Diode 20A90M
P200 COIL & TRANSFORMER				
L201	1	1	LI1401623	IFT FM
L202	1	1	LC1332002	Choke Coil 3.3μH
P200 PLUG				
J201	~	11	YP1000113	Plug
J211	~	11	YP1000113	Plug
P300 FM MPX BOARD				
P300	1	1	YD2890003	PW Board
	1	1	ZZ2916103	PW Board Assembly

REF. DESIG.	U	E	PART NO.	DESCRIPTION
P300 RESISTORS				
R301	1	1	RA0202011	Trimming Resist 2KΩ B
R302	1	1	RT0522414	Resistor 220KΩ
R303	1	1	RT0556314	Resistor 56KΩ
R304	1	1	RT0568314	Resistor 68KΩ
R305	1	1	RT0510114	Resistor 100Ω
R306	1	1	RT0518414	Resistor 180KΩ
R307	1	1	RT0522414	Resistor 220KΩ
R308	1	1	RT0512414	Resistor 120KΩ
R309	1	1	RT0510414	Resistor 100KΩ
R310	1	1	RT0568214	Resistor 6.8KΩ
R311	1	1	RA0502020	Trimming Resist 5KΩ B
R312	1	1	RT0516314	Resistor 16KΩ
R313	1	1	RT0510214	Resistor 1KΩ
R314	1	1	RT0522414	Resistor 220KΩ
R315	1	1	RT0510214	Resistor 1KΩ
R316	1	1	RT0510214	Resistor 1KΩ
R317	1	1	RT0539214	Resistor 3.9KΩ
R318	1	1	RT0539214	Resistor 3.9KΩ
R319	1	1	RT0522414	Resistor 220KΩ
R320	1	1	RT0522314	Resistor 22KΩ
R321	1	1	RT0510114	Resistor 100Ω
R322	1	1	RT0510014	Resistor 10Ω
R323	1	1	RT0522414	Resistor 220KΩ
R324	1	1	RT0522414	Resistor 220KΩ
R325	1	1	RT0530314	Resistor 30KΩ
R326	1	1	RT0530314	Resistor 30KΩ
R327	1	1	RT0510414	Resistor 100KΩ
R328	1	1	RT0510414	Resistor 100KΩ
R329	1	1	RT0515514	Resistor 1.5MΩ
R330	1	1	RT0515514	Resistor 1.5MΩ
R331	1	1	RT0551114	Resistor 510Ω
R332	1	1	RT0551114	Resistor 510Ω
R333	1	1	RT0522314	Resistor 22KΩ
R334	1	1	RT0522314	Resistor 22KΩ
R335	1	1	RT0510114	Resistor 100Ω
R336	1	1	RT0510114	Resistor 100Ω
R337	1	1	RT0582214	Resistor 8.2KΩ
R338	1	1	RT0582214	Resistor 8.2KΩ
R339	1	1	RT0547114	Resistor 470Ω
R340	1	1	RT0547114	Resistor 470Ω
R341	1	1	RT0522414	Resistor 220KΩ
R342	1	1	RT0522414	Resistor 220KΩ
R343	1	1	RT0539214	Resistor 3.9KΩ
R344	1	1	RT0556414	Resistor 560KΩ
R345	1	1	RT0515314	Resistor 15KΩ
R346	1	1	RT0512414	Resistor 120KΩ
R347	1	1	RT0510114	Resistor 100Ω
R348	1	1	RT0522414	Resistor 220KΩ
R349	1	1	RT0556214	Resistor 5.6KΩ
R350	1	1	RT0510314	Resistor 10KΩ
R351	1	1	RT0510114	Resistor 100Ω
R352	1	1	RT0533314	Resistor 33KΩ
R353	1	1	RT0510114	Resistor 100Ω
R354	1	1	RT0510414	Resistor 27KΩ
R355	1	1	RT0527314	Resistor 100KΩ
R356	1	1	RT0510414	Resistor 100KΩ
R357	1	1	RT0510214	Resistor 1KΩ
R358	1	1	RT0510114	Resistor 100Ω
R359	1	1	RT0527314	Resistor 27KΩ
R360	1	1	RT0533314	Resistor 33KΩ
R361	1	1	RT0522414	Resistor 220KΩ
R362	1	1	RA0104018	Trimming Resist 100KΩ B
R363	1	1	RA0103025	Trimming Resist 10KΩ B

REF. DESIG.	U	E	PART NO.	DESCRIPTION
R364	1	1	RT0522214	Resistor 2.2KΩ
R365	1	1	RT0510114	Resistor 100Ω
R366	1	1	RT0510314	Resistor 10KΩ
R367	1	1	RT0510114	Resistor 100Ω
R368	1	1	RT0527414	Resistor 270KΩ
R369	1	1	RT0515314	Resistor 15KΩ
R370	1	1	RT0512314	Resistor 12KΩ
R371	1	1	RT0522114	Resistor 220Ω
R372	1	1	RT0527414	Resistor 270KΩ
R373	1	1	RT0533314	Resistor 33KΩ
R374	1	1	RA0103025	Trimming Resist 10KΩ B
R375	1	1	RT0510114	Resistor 100Ω
R376	1	1	RT0510414	Resistor 100KΩ
R377	1	1	RT0510414	Resistor 100KΩ
R378	1	1	RT0556214	Resistor 5.6KΩ
R379	1	1	RT0522214	Resistor 2.2KΩ
C301	1	1	DF1622205	Film Cap 2200PF ±10%
C302	1	1	EA3360109	Electroly Cap 33μF 10V
C303	1	1	DF1722305	Film Cap 0.022μF ±20%
C304	1	1	EA2260169	Electroly Cap 22μF 16V
C305	1	1	DF5547101	Film Cap 470PF ±5%
C306	1	1	EA2260169	Electroly Cap 22μF 16V
C307	1	1	EQ4740501	Electroly Cap 0.47μF±20%50V
C308	1	1	EQ2240501	Electroly Cap 0.22μF±20%50V
C309	1	1	EQ2240501	Electroly Cap 0.22μF±20%50V
C310	1	1	DF1747301	Film Cap 0.047μF±20%50V
C311	1	1	DF1515205	Film Cap 1500PF ±5%
C312	1	1	DF1515205	Film Cap 1500PF ±5%
C313	1	1	DD1536101	Ceramic Cap 360PF ±5%
C314	1	1	DD1536101	Ceramic Cap 360PF ±5%
C315	1	1	DF1533205	Film Cap 3300PF ±5%
C316	1	1	DF1533205	Film Cap 3300PF ±5%
C317	1	1	DF1515205	Film Cap 1500PF ±5%
C318	1	1	DF1515205	Film Cap 1500PF ±5%
C319	1	1	DF1522205	Film Cap 2200PF ±5%
C320	1	1	DF1522205	Film Cap 2200PF ±5%
C321	1	1	DF1510205	Film Cap 1000PF ±5%
C322	1	1	DF1510205	Film Cap 1000PF ±5%
C323	1	1	EV2240351	Electroly Cap 0.22μF±20%35V
C324	1	1	EV2240351	Electroly Cap 0.22μF±20%35V
C325	1	1	EV1050352	Electroly Cap 1μF±20%35V
C326	1	1	EV1050352	Electroly Cap 1μF±20%35V
C327	1	1	EA270259	Electroly Cap 220μF 25V
C328	1	1	EA2270169	Electroly Cap 220μF 16V
C329	1	1	EA1060169	Electroly Cap 10μF 16V
C330	1	1	DK1840302	Ceramic Cap 0.04μF ±20%
C331	1	1	EA1050509	Electroly Cap 1μF 50V
C332	1	1	EA1060169	Electroly Cap 10μF 16V
C333	1	1	DD1210001	Ceramic Cap 10PF ±10%
C334	1	1	DF1668301	Film Cap 0.068μF ±10%
C335	1	1	DF1740301	Film Cap 0.04μF ±20%
C336	1	1	DK1810402	Ceramic Cap 0.1μF ±20%
C337	1	1	EA4750359	Electroly Cap 4.7μF 35V
C338	1	1	EA1050509	Electroly Cap 1μF 50V
C339	1	1	DK1840302	Ceramic Cap 0.04μF ±20%
C340	1	1	DK1840302	Ceramic Cap 0.04μF ±20%
C341	1	1	DK1840302	Ceramic Cap 0.04μF ±20%
C343	1	1	DF1710402	Film Cap 0.1μF ±20%
H301	1	1	HF200301C	FET 2SK30 (Y)
H302	1	1	HT308281D	Transistor 2SC828S
H303	1	1	HT308281D	Transistor 2SC828S
H304	1	1	HT307322A	Transistor 2SC732 B or G

U: For U.S.A.
E: For Europe

REF. DESIG.	U	E	PART NO.	DESCRIPTION
H305	1	1	HT307322A	Transistor 2SC732 B or G
H306	1	1	HT104942A	Transistor 2SA494 G or Y
H307	1	1	HT104942A	Transistor 2SA494 G or Y
H308	1	1	HT308281D	Transistor 2SC828S
H309	1	1	HT308281D	Transistor 2SC828S
H310	1	1	HT308281D	Transistor 2SC828S
H311	1	1	HT308281D	Transistor 2SC828S
H312	1	1	HF200300A	FET 2SC828S
H313	1	1	HT308281D	Transistor 2SC828S
H314	1	1	HT308281D	Transistor 2SC828S
H315	1	1	HT308281D	Transistor 2SC828S
H316	1	1	HT308281D	Transistor 2SC828S
H317	1	1	HT308281D	Transistor 2SC828S
H318	1	1	HD1000105	Diode 1N60
H319	1	1	HD1000105	Diode 1N60
H321	1	1	HC1000401	IC IC HA1156
L301	1	1	LS1029004	MPX Coil 56mH
L302	1	1	LS1029004	MPX Coil 56mH
L303	1	1	LS1029005	MPX Coil 43mH
L304	1	1	LS1029005	MPX Coil 43mH
L305	1	1	LC2105001	Choke Coil 1mH
J322				
~	22	22	YP1000113	Plug
J320				
P400	1	1	YD892008	P W Board Phono Amp.
	1	1	ZZ2916108	P W Board Assembly
R401	1	1	RT0556314	Resistor 56K Ω
R402	1	1	RT0556314	Resistor 56K Ω
R403	1	1	RT0547114	Resistor 470 Ω
R404	1	1	RT0547114	Resistor 470 Ω
R405	1	1	RN0533314	Resistor 33K Ω
R406	1	1	RN0510514	Resistor 1M Ω
R407	1	1	RN0510514	Resistor 1M Ω
R408	1	1	RA0104015	Trimming Resist 100K Ω B \pm 30%
R409	1	1	RA0104015	Trimming Resist 100K Ω B \pm 30%
R410	1	1	RN0527314	Resistor 27K Ω
R411	1	1	RN0527314	Resistor 27K Ω
R412	1	1	RT0562114	Resistor 620 Ω
R413	1	1	RT0562114	Resistor 620 Ω
R414	1	1	RT0522514	Resistor 2.2M Ω
R415	1	1	RT0522514	Resistor 2.2M Ω
R416	1	1	RN0522514	Resistor 2.2M Ω
R417	1	1	RN0522514	Resistor 2.2M Ω
R418	1	1	RN0527414	Resistor 270K Ω
R419	1	1	RN0527414	Resistor 270K Ω
R420	1	1	RT0547314	Resistor 47K Ω
R421	1	1	RT0547314	Resistor 47K Ω
R422	1	1	RT0522214	Resistor 2.2K Ω
R423	1	1	RT0522214	Resistor 2.2K Ω
R424	1	1	RN0568414	Resistor 680K Ω
R425	1	1	RN0568414	Resistor 680K Ω
R426	1	1	RN0510414	Resistor 100K Ω
R427	1	1	RN0510414	Resistor 100K Ω
R428	1	1	RN0547314	Resistor 47K Ω
R429	1	1	RN0547314	Resistor 47K Ω
R430	1	1	RT0547014	Resistor 47 Ω
R431	1	1	RT0547014	Resistor 47 Ω

REF. DESIG.	U	E	PART NO.	DESCRIPTION
R432	1	1	RN0533214	Resistor 3.3K Ω
R433	1	1	RN0533214	Resistor 3.3K Ω
R434	1	1	RT0510114	Resistor 100 Ω
R435	1	1	RT0547014	Resistor 47 Ω
R436	1	1	RT0547014	Resistor 47 Ω
C401	1	1	EV1050256	Electroly Cap 1 μ F 25V \pm 20%
C402	1	1	EV1050256	Electroly Cap 1 μ F 25V \pm 20%
C403	1	1	EE4760163	Electroly Cap 47 μ F 16V \pm 20%
C404	1	1	EE4760163	Electroly Cap 47 μ F 16V \pm 20%
C405	1	1	DD1540004	Ceramic Cap 40PF 50V \pm 5%
C406	1	1	DD1540004	Ceramic Cap 40PF 50V \pm 5%
C407	1	1	DD1104001	Ceramic Cap 4PF 50V 0.5P
C408	1	1	DD1104001	Ceramic Cap 4PF 50V 0.5P
C409	1	1	DF6556201	Film Cap 5600PF 50V \pm 5%
C410	1	1	DF6556201	Film Cap 5600PF 50V \pm 5%
C411	1	1	DF6516201	Film Cap 1600PF 50V \pm 5%
C412	1	1	DF6516201	Film Cap 1600PF 50V \pm 5%
C413	1	1	ED1070351	Electroly Cap 100 μ F 35V \pm 5%
C414	1	1	DF1710551	Film Cap 1 μ F 250V \pm 20%
C415	1	1	DF1710551	Film Cap 1 μ F 250V \pm 20%
D416	1	1	DD1650001	Ceramic Cap 50PF 250V \pm 10%
C417	1	1	DD1650001	Ceramic Cap 50PF 250V \pm 10%
H401	1	1	HT313441E	Transistor 2SC1344 E
H402	1	1	HT313441E	Transistor 2SC1344 E
H403	1	1	HT313442A	Transistor 2SC1344 D, E
H404	1	1	HT313442A	Transistor 2SC1344 D, E
H405	1	1	HT304580R	Transistor 2SC458L, B
H406	1	1	HT304580R	Transistor 2SC458L, B
H407	1	1	HD2000121	Varistor 1S-2473C, Ye
H408	1	1	HD2000121	Varistor 1S-2473C, Ye
H409	1	1	HV0000206	Varistor VD1212
J401				
~	8	8	YP1000113	Plug
J408				
2011	8	8	51100306S	B H M Screw B 3 x 6
P700	2	2	YD2916001	P700 MAIN AMP. BOARD
	2	2	ZZ2916001	P W Board Main Amp. (94V-1)
				P W Board Assembly
R701	2	2	RT0518214	P700 Resistors Resistor 1.8K Ω $\frac{1}{4}$ W \pm 5%
R702	2	2	RT0533314	Resistor 33K Ω $\frac{1}{4}$ W \pm 5%
R703	2	2	RT0568214	Resistor 6.8K Ω $\frac{1}{4}$ W \pm 5%
R704	2	2	RT0510214	Resistor 1K Ω $\frac{1}{4}$ W \pm 5%
R705	2	2	RT0510114	Resistor 100 Ω $\frac{1}{4}$ W \pm 5%
R706	2	2	RT0556314	Resistor 56K Ω $\frac{1}{4}$ W \pm 5%
R707	2	2	RA0502017	Trimming Res. 5K Ω (B)
R708	2	2	RT0547214	Resistor 4.7K Ω $\frac{1}{4}$ W \pm 5%
R709	2	2	RT0518414	Resistor 180K Ω $\frac{1}{4}$ W \pm 5%
R710	2	2	RT0518214	Resistor 1.8K Ω $\frac{1}{4}$ W \pm 5%
R711	2	2	RT0522314	Resistor 22K Ω $\frac{1}{4}$ W \pm 5%
R712	2	2	RT0518214	Resistor 1.8K Ω $\frac{1}{4}$ W \pm 5%
R713	2	2	RC1010212	Resistor 1K Ω $\frac{1}{4}$ W \pm 10%
R714	2	2	RT0533314	Resistor 33K Ω $\frac{1}{4}$ W \pm 5%
R715	2	2	GF0547214	Resistor 4.7K Ω $\frac{1}{4}$ W \pm 5%
R716	2	2	GF0533014	Resistor 33 Ω $\frac{1}{4}$ W \pm 5%
R717	2	2	HH0000303	Thermistor STD 04
R718	2	2	RT0575014	Resistor 75 Ω $\frac{1}{4}$ W \pm 5%
R719	2	2	RA0301002	Trimming Res. 300 Ω (B)
R720	2	2	GF0520114	Resistor 200 Ω $\frac{1}{4}$ W \pm 5%

REF. DESIG.	U	E	PART NO.	DESCRIPTION
R721	2	2	GF0536114	Resistor 360Ω ¼W ±5%
R722	2	2	GF0547214	Resistor 4.7KΩ ¼W ±5%
R723	2	2	GF0510214	Resistor 1KΩ ¼W ±5%
R724	2	2	GF0510214	Resistor 1KΩ ¼W ±5%
R725	2	2	GF0510114	Resistor 100Ω ¼W ±5%
R726	2	2	GF0510114	Resistor 100Ω ¼W ±5%
R727	2	2	GF0510114	Resistor 100Ω ¼W ±5%
R728	2	2	GF0522114	Resistor 220Ω ¼W ±5%
R729	2	2	GF0510014	Resistor 10Ω ¼W ±5%
R730	2	2	GF0510014	Resistor 10Ω ¼W ±5%
R731	2	2	GF0522114	Resistor 220Ω ¼W ±5%
R732	2	2	GW1020205	Resistor 0.2Ω 5W ±10%
R733	2	2	GW1020205	Resistor 0.2Ω 5W ±10%
R734	2	2	RC1002212	Resistor 2.2Ω ½W ±10%
R735	2	2	GJ0510002	Resistor 10Ω 2W ±5%
R736	2	2	RT0510114	Resistor 100Ω ¼W ±5%
R737	2	2	RC0000012	Resistor 0Ω
C701	2	2	EE3350251	Electroly Cap 3.3μF 25V ±25%
C702	2	2	EA1060359	Electroly Cap 10μF 35V
C703	2	2	DD1620101	Ceramic Cap 200PF 50V
C704	2	2	EA4760509	Electroly Cap 47μF 50V
C705	2	2	EE4760162	Electroly Cap 47μF 10V ±20%
C706	2	2	EA2270509	Electroly Cap 220μF 50V
C707	2	2	DD1003050	Ceramic Cap 3PF 500V
C708	2	2	DF1710305	Film Cap 0.01μF 50V
C709	2	2	DF1710305	Film Cap 0.01μF 50V
C710	2	2	DF1710452	Film Cap 0.1μF 200V
C711	2	2	DK1610150	Ceramic Cap 100PF
J701	2	2		
~	14	14	YP1000114	Plug
J714	2	2		
H701	2	2	HD3003009	Diode WZ-177
H702	2	2	HT107631B	Transistor 2SA763
H703	1	1	HT107631B	Transistor 2SA763
H704	1	1	HV0000312	Diode MV-13
H707	2	2	HT308753B	Transistor 2SC875 C.D.E.
H708	2	2	HD2000221	Diode 1S2472 (Gr)
H709	2	2	HD2000221	Diode 1S2472 (Gr)
H710	2	2	HT309451Q	Transistor 2SC945 Q
H711	2	2	HT107331Q	Transistor 2SA733 Q
H712	2	2	HD2000221	Diode 1S2472 (Gr)
H713	2	2	HD2000221	Diode 1S2472 (Gr)
H714	1	1	HT404151P	Transistor 2SD415 P.Q.R.
H715	1	1	HT205491P	Transistor 2SB549 P.Q.R.
L701	2	2	LC2262001	Coil
2028	4	4	291626701	Heat Sink
2029	2	2	112600501	Clamper
2031	4	4	51100308E	B H M Screw B 3 x 8
2032	4	4	53110301E	Hexagon Nut
2021	2	2	281811806	Spacer
2605	2	2	62030039W	Lug
2003	2	2	282026701	Heat Sink
2005	4	4	282016007	Bracket
2006	16	16	51380306T	R H Tap Screw
2010	8	8	281810104	Support
2015	8	8	51100312E	B H M Screw B 3 x 12
2018	2	2	282026702	Heat Sink
2019	2	2	51060308S	P H M Screw P 3 x 8
2023	2	2	51570408B	P H Tapt Screw P 4 x 8ST
2024	2	2	291605502	Collar

REF. DESIG.	U	E	PART NO.	DESCRIPTION
H001	1	1	HT314031A	Transistor 2SC1403 R.O
H002	1	1	HT314031A	Transistor 2SC1403 R.O
H003	1	1	HT314031A	Transistor 2SC1403 R.O
H004	1	1	HT314031A	Transistor 2SC1403 R.O
H005	1	1	HV0000212	Diode SV-3A
H006	1	1	HV0000212	Diode SV-3A
J016	1	1	YJ0500019	Socket
J018	1	1	YJ0500019	Socket
J017	1	1	YJ0500019	Socket
J019	1	1	YJ0500019	Socket
2712	2	2	121000501	Clamper
P800	1	1	YD2916002	P.W. Board Power Supply
	1	1	ZZ2916002	P.W. Board Assembly
P800	1	1		P800 RESISTORS
R801	1	1	GF0510012	Resistor 10Ω ¼W ±5%
R802	1	1	RT0547214	Resistor 4.7KΩ ¼W ±5%
R803	1	1	RT0547214	Resistor 4.7KΩ ¼W ±5%
R804	1	1	RT0539214	Resistor 3.9KΩ ¼W ±5%
R805	1	1	RT0522314	Resistor 22KΩ ¼W ±5%
R806	1	1	RA0502013	Trimming Res. 5KΩ (B)
R807	1	1	GS1015105	Resistor 150Ω 5W ±10%
R808	1	1	RT0533214	Resistor 3.3KΩ ¼W ±5%
R809	1	1	RT0510014	Resistor 10Ω ¼W ±5%
R810	1	1	RT0518314	Resistor 18KΩ ¼W ±5%
R811	1	1	RT0515314	Resistor 15KΩ ¼W ±5%
R812	1	1	RT0568214	Resistor 6.8KΩ ¼W ±5%
R813	1	1	RT0524414	Resistor 240KΩ ¼W ±5%
R814	1	1	RT0539314	Resistor 39KΩ ¼W ±5%
R815	1	1	GU0568112	Resistor 680Ω ½W ±5%
R816	1	1	GU0556212	Resistor 5.6KΩ ¼W ±5%
R817	1	1	GU0556212	Resistor 5.6KΩ ¼W ±5%
R818	1	1	RT0556214	Resistor 5.6KΩ ¼W ±5%
P800	1	1		P800 CAPACITORS
C801	1	1	EA2270631	Electroly Cap 220μF 63V
C802	1	1	EA1070509	Electroly Cap 100μF 50V
C803	1	1	DF1710305	Film Cap 0.01μF 50V
C804	1	1	EA2260359	Electroly Cap 22μF 35V
C805	1	1	EA3370509	Electroly Cap 330μF 50V
C806	1	1	EA4770164	Electroly Cap 470μF 16V
C807	1	1	EA1060509	Electroly Cap 10μF 50V
C808	1	1	EA4760169	Electroly Cap 42μF 16V
C809	1	1	EA2270109	Electroly Cap 220μF 10V
C810	1	1	DK1810351	Ceramic Cap 0.01μF 200V
P800	1	1		P800 SEMICONDUCTORS
H801	1	1	HT403302A	Transistor 2SD330 DE
H802	1	1	HT313183A	Transistor 2SC1318 P.Q.R.
H803	1	1	HT309452A	Transistor 2SC945 Q.R.
H804	1	1	HT403314A	Transistor 2SD331 CDEF
H805	1	1	HT309452A	Transistor 2SC945 Q.R.
H806	1	1	HT313182R	Transistor 2SC1318 R.S.
H807	1	1	HT313182R	Transistor 2SC1318 R.S.
H808	1	1	HD2001103	Diode DS131-B
H809	1	1	HD3002309	Diode WZ-071
H810	1	1	HD3002709	Diode WZ-140
H811	1	1	HD2001103	Diode DS131B
H812	1	1	HD2000321	Diode 1S2471
P800	1	1		P800 RELAY
L801	1	1	LY2024006	Relay MY2 24V

U: For U.S.A.
E: For Europe

REF. DESIG.	U	E	PART NO.	DESCRIPTION
P800 PLUGS				
J801 ~ J810	10	10	YP1000113	Plug
2103	1	1	291626702	Heat Sink
2104	2	2	51102606S	B H M Screw B 2.6 x 6
2105	1	1	51100310E	B H M Screw B 3 x 10
2106	1	1	53110301E	Hexagon Nut
2614	1	1	62030039W	Lug
PC01 DOLBY LEVEL BOARD				
PC01	1	1	YD2916003	P.W. Board Dolby Level
	1	1	ZZ2916003	P.W. Board Assembly
PC01 Resistors				
RC01	1	1	RA0104015	Trimming Res. 100K (B)
RC02	1	1	RA0104015	Trimming Res. 100K (B)
RC03	1	1	RT0568314	Resistor 68KΩ ¼W ±5%
RC04	1	1	RT0568314	Resistor 68KΩ ¼W ±5%
RC05	1	1	RT0510414	Resistor 100KΩ ¼W ±5%
RC06	1	1	RT0510414	Resistor 100KΩ ¼W ±5%
RC07	1	1	RT0539214	Resistor 3.9KΩ ¼W ±5%
RC08	1	1	RT0539214	Resistor 3.9KΩ ¼W ±5%
RC09	1	1	RT0510414	Resistor 100KΩ ¼W ±5%
RC10	1	1	RT0510414	Resistor 100KΩ ¼W ±5%
PC01 CAPACITORS				
CC01	1	1	EV1050256	Electroly Cap 1μF 25V
CC02	1	1	EV1050256	Electroly Cap 1μF 25V
CC03	1	1	EV1050256	Electroly Cap 1μF 25V
CC04	1	1	EV1050256	Electroly Cap 1μF 25V
PC01 PLUGS				
JC01 ~ JC08	8	8	YP1000113	Plug
PC 01 SEMICONDUCTORS				
HC01	1	1	HT313272A	Transistor 2SC1327 S.T
HC02	1	1	HT313272A	Transistor 2SC1327 S.T
2620	1	1	62030039W	Lug
1603	1	1	291630201	Dial
1604	1	1	291630202	Dial
1605	1	1	291630203	Dial
1606	1	1	285610701	Sheet
0803	1	1	291516050	Bracket K
0806		2	288410102	Support
0810	1	1	291512002	Insulator
0811	2	2	51100306A	B H M Screw B 3 x 6
0813	4	4	51100306A	B H M Screw B 3 x 6
0817	2	2	51100306A	B H M Screw B 3 x 6
0822	2	2	51100306A	B H M Screw B 3 x 6
0827	2	2	51470306A	B H M Screw B 3 x 4
0833	2	2	51100304A	B H M Screw B 3 x 4
0834	1	1	288612002	Insulator
0835	1	1	291612001	Insulator
0903	1	1	281816003	Bracket
0904	1	1	281816004	Bracket
0905	4	4	51100406A	B H M Screw B 4 x 6
1010	2	2	51042608A	F H M Screw F 2.6 x 8
1111	2	2	51570306B	P H Tapt Screw P 3 x 6 ST
1112	2	2	54050300R	T L Washer Or
1403	1	1	257710602	Bearing

REF. DESIG.	U	E	PART NO.	DESCRIPTION
1404	1	1	141511801	Spacer
1405	2	2	51040306A	F H M Screw F 3 x 6
1608	1	1	285326901	Protector
1609	2	2	51570306B	P H Tapt Screw P 3 x 6 ST
1622	1	1	288612201	Sticker
1624	1	1	281912005	Insulator
R002	1	1	RS0504002	Variable Res. Balance 500K
PZ01 DIAL LAMP BOARD				
PZ01	1	1	YD2886016	P. W. Board Dial Lamp
	1	1	ZZ2916116	P. W. Board Assembly
PZ01 LAMPS				
MZ01	1	1	IN1008036	Lamp
MZ02	1	1	IN1008036	Lamp
MZ03	1	1	IN1008036	Lamp
MZ04	1	1	IN1008036	Lamp
MZ05	1	1	IN1008036	Lamp
PZ01 SOCKETS				
JZ01	1	1	YJ0800017	Socket
JZ02	1	1	YJ0800017	Socket
JZ03	1	1	YJ0800017	Socket
JZ04	1	1	YJ0800017	Socket
JZ05	1	1	YJ0800017	Socket
JZ06	1	1	YJ0800017	Socket
JZ07	1	1	YJ0800017	Socket
JZ08	1	1	YJ0800017	Socket
JZ09	1	1	YJ0800017	Socket
JZ10	1	1	YJ0800017	Socket
PZ01 PLUGS				
JZ11 ~ JZ14	4	4	YP1000113	Plug
0917	1	1	287127401	Reflector
0909	1	1	287127101	Holder
0920	2	2	51570306B	P H Tapt Screw
0926	2	2	51100306A	B H M Screw B 3 x 6
0927	2	2	51480306A	B H M Screw F
PY01 FUNCTION LAMP BOARD				
PY01	1	1	YD2916006	P W Board Function Lamp
	1	1	ZZ2916116	P W Board Assembly
PY01 LAMPS				
MY01	1	1	IN1008037	Lamp DOLBY 8V 40mA
MY02	1	1	IN1008037	Lamp AM 8V 40mA
MY03	1	1	IN1008037	Lamp FM 8V 40mA
MY04	1	1	IN1008037	Lamp PHONO 8V 40mA
MY05	1	1	IN1008037	Lamp Aux 8V 40mA
MY06	1	1	IN1008037	Lamp TAPE 1 8V 40mA
MY07	1	1	IN1008037	Lamp TAPE 2 8V 40mA
MY08	1	1	IN1012011	Lamp STEREO 12V 40mA
PY01 PLUGS				
JY01 ~ JY11	12	12	YP1000113	Plug
0922	1	1	288627101	Holder
0923	2	2	51570306B	P H Tapt Screw P 3 x 6 ST
1022	1	1	288627401	Reflector
1026	1	1	288926251	Pulley K
1032	2	2	51100306A	B H M Screw B 3 x 6
1033	2	2	54050300R	T L Washer OR

REF. DESIG.	U	E	PART NO.	DESCRIPTION
1107	2	2	51480306A	B H M Screw F
1115	1	1	288610701	Sheet
M002	1	1	IM1104202	Meter FM
M001	1	1	IM1104203	Meter Signal
C003	1	1	EA3360109	Electroly Cap 33 μ F 10V
5636	1	1	288610701	Sheet
1103	1	1	288627102	Holder
1104	2	2	51570306B	P H Tapt Screw x 2 P 3 x 6 ST
M003	1	1	IN1008036	Lamp METER LAMP
M004	1	1	IN1008036	Lamp METER LAMP
J008	1	1	YJ0800019	Socket METER LAMP
J009	1	1	YJ0800019	Socket METER LAMP
0934	1	1	287105102	Guide
1002	1	1	288926250	Pulley K
1107	2	2	51100305A	B H M Screw B 3 x 5
J005	1	1	YJ0100081	Jack DUBBING IN
J006	1	1	YJ0100098	Jack DUBBING OUT
0821	1	1	291616002	Bracket
0816	1	1	291616003	Bracket POWER Head Phone
0818	2	2	51060306A	P H M Screw P 3 x 6
S00Z	1	1	SP0201015	Push SW POWER SW
J013	1	1	YJ0100098	Jack Head Phone
S001	1	1	SR1006014	Rotaly SW
R001	1	1	RM0254022	Variable Resist Volume 250K
PE01 PRE-TONE AMP. BOARD				
All resistors are $\pm 5\%$ and $\frac{1}{4}W$, unless otherwise indicated.				
PE01	1	1	YD2915004	P W Board Pre-Tone Amp.
	1	1	ZZ2916104	P.W. Board Assembly
PE01 RESISTORS				
RE01	1	1	RT0547414	Resistor 470K Ω
RE02	1	1	RT0547414	Resistor 470K Ω
RE03	1	1	RT0539114	Resistor 390 Ω
RE04	1	1	RT0539114	Resistor 390 Ω
RE05	1	1	RN0510514	Resistor 1M Ω
RE06	1	1	RN0510514	Resistor 1M Ω
RE07	1	1	RN0510414	Resistor 100K Ω
RE08	1	1	RT0510314	Resistor 10K Ω
RE09	1	1	RT0527314	Resistor 27K Ω
RE10	1	1	RT0527314	Resistor 27K Ω
RE11	1	1	RT0510214	Resistor 1K Ω
RE12	1	1	RT0510214	Resistor 1K Ω
RE13	1	1	RT0551214	Resistor 5.1K Ω
RE14	1	1	RT0551214	Resistor 5.1K Ω
RE15	1	1	RT0510214	Resistor 1K Ω
RE16	1	1	RT0510214	Resistor 1K Ω
RE17	1	1	RT0547414	Resistor 470K Ω
RE18	1	1	RT0547414	Resistor 470K Ω
RE19	1	1	RT0556214	Resistor 5.6K Ω
RE20	1	1	RT0556214	Resistor 5.6K Ω
RE21	1	1	RT0512314	Resistor 12K Ω
RE22	1	1	RT0512314	Resistor 12K Ω
RE23	1	1	RT0515414	Resistor 150K Ω
RE24	1	1	RT0515414	Resistor 150K Ω
RE25	1	1	RT0556214	Resistor 5.6K Ω
RE26	1	1	RT0556214	Resistor 5.6K Ω
RE27	1	1	RT0556214	Resistor 5.6K Ω
RE28	1	1	RT0556214	Resistor 5.6K Ω
RE29	1	1	RT0527314	Resistor 27K Ω
RE30	1	1	RT0527314	Resistor 27K Ω

REF. DESIG.	U	E	PART NO.	DESCRIPTION
RE31	1	1	RT0512314	Resistor 12K Ω
RE32	1	1	RT0512314	Resistor 12K Ω
RE33	1	1	RT0515314	Resistor 15K Ω
RE34	1	1	RT0515314	Resistor 15K Ω
RE35	1	1	RT0547414	Resistor 470K Ω
RE36	1	1	RT0547414	Resistor 470K Ω
RE37	1	1	RT0527314	Resistor 27K Ω
RE38	1	1	RT0527314	Resistor 27K Ω
RE39	1	1	RT0522514	Resistor 2.2M Ω
RE40	1	1	RT0522514	Resistor 2.2M Ω
RE41	1	1	RT0568314	Resistor 68K Ω
RE42	1	1	RT0568314	Resistor 68K Ω
RE43	1	1	RT0547314	Resistor 47K Ω
RE44	1	1	RT0547314	Resistor 47K Ω
RE45	1	1	RT0510314	Resistor 10K Ω
RE46	1	1	RT0510314	Resistor 10K Ω
RE47	1	1	RT0522114	Resistor 220 Ω
RE48	1	1	RT0522114	Resistor 220 Ω
RE49	1	1	RT0547414	Resistor 470K Ω
RE50	1	1	RT0547414	Resistor 470K Ω
RE51	1	1	RD0104005	Variable Resist 100K Ω (B)HIGH
RE52	1	1	RD0104005	Variable Resist 100K Ω MID
RE53	1	1	RD0104005	Variable Resist 100K Ω LOW
RE54	1	1	RT0582114	Resistor 820 Ω
PE01 CAPACITORS				
CE01	1	1	DF1722405	Film Cap 0.22 μ F 50V $\pm 20\%$
CE02	1	1	DF1722405	Film Cap 0.22 μ F 50V $\pm 20\%$
CE03	1	1	EA1060359	Electroly Cap 10 μ F 35V $\pm 10\%$
CE04	1	1	EA1060359	Electroly Cap 10 μ F 35V $\pm 10\%$
CE05	1	1	EE4750251	Electroly Cap 47 μ F 25V $\pm 20\%$
CE06	1	1	EE4750251	Electroly Cap 47 μ F 25V $\pm 20\%$
CE07	1	1	DD1610101	Ceramic Cap 100PF 50V $\pm 10\%$
CE08	1	1	DD1610101	Ceramic Cap 100PF 50V $\pm 10\%$
CE09	1	1	DF1622205	Film Cap 2200PF 50V $\pm 10\%$
CE10	1	1	DF1622205	Film Cap 2200PF 50V $\pm 10\%$
CE11	1	1	DF1668205	Film Cap 6800PF 50V $\pm 10\%$
CE12	1	1	DF1668205	Film Cap 6800PF 50V $\pm 10\%$
CE13	1	1	DF1622305	Film Cap 0.022 μ F 50V $\pm 10\%$
CE14	1	1	DF1622305	Film Cap 0.022 μ F 50V $\pm 10\%$
CE15	1	1	DF1622305	Film Cap 0.022 μ F 50V $\pm 10\%$
CE16	1	1	DF1622305	Film Cap 0.022 μ F 50V $\pm 10\%$
CE17	1	1	DF1610305	Film Cap 0.01 μ F 50V $\pm 10\%$
CE18	1	1	DF1610305	Film Cap 0.01 μ F 50V $\pm 10\%$
CE19	1	1	EE1050501	Electroly Cap 1 μ F 50V $\pm 20\%$
CE20	1	1	EE1050501	Electroly. Cap 1 μ F 50V $\pm 20\%$
CE21	1	1	EE3350501	Electroly Cap 33 μ F 50V $\pm 20\%$
CE22	1	1	EE3350501	Electroly Cap 33 μ F 50V $\pm 20\%$
CE23	1	1	EQ1050501	Electroly Cap 1 μ F 50V $\pm 30\%$
CE24	1	1	EQ1050501	Electroly Cap 1 μ F 50V $\pm 30\%$
CE25	1	1	EA1070359	Electroly Cap 100 μ F 35V $\pm 10\%$
PE01 SEMICONDUCTORS				
HE01	1	1	HT313283A	Transistor 2SC1328 S.T.U.
HE02	1	1	HT313283A	Transistor 2SC1328 S.T.U.
HE03	1	1	HT107632A	Transistor 2SA763
HE04	1	1	HT107632A	Transistor 2SA763
HE05	1	1	HT313283A	Transistor 2SC1328 S.T.U.
HE06	1	1	HT313283A	Transistor 2SC1328 S.T.U.
HE07	1	1	HT107632A	Transistor 2SA763
HE08	1	1	HT107632A	Transistor 2SA763
PE01 PLUGS				
JE01				
~	8	8	YP1000113	Plug
JE08				

REF. DESIG.	U	E	PART NO.	DESCRIPTION
PH01	1	1	YD2916005	PH01 FILTER BOARD P.W. Board Filter FILTER SP(94V-1)
	1	1	ZZ2916005	P.W. Board Assembly
PH01 RESISTORS				
RH01	1	1	RT0510414	Resistor 100KΩ ¼W ±5%
RH02	1	1	RT0510414	Resistor 100KΩ ¼W ±5%
RH03	1	1	RT0512314	Resistor 12KΩ ¼W ±5%
RH04	1	1	RT0512314	Resistor 12KΩ ¼W ±5%
RH05	1	1	RT0510514	Resistor 1MΩ ¼W ±5%
RH06	1	1	RT0510514	Resistor 1MΩ ¼W ±5%
RH07	1	1	RT0510414	Resistor 100KΩ ¼W ±5%
RH08	1	1	RT0510414	Resistor 100KΩ ¼W ±5%
RH09	1	1	RT0536214	Resistor 3.6KΩ ¼W ±5%
RH10	1	1	RT0536214	Resistor 3.6KΩ ¼W ±5%
RH11	1	1	RT0522514	Resistor 2.2MΩ ¼W ±5%
RH12	1	1	RT0522514	Resistor 2.2MΩ ¼W ±5%
RH13	1	1	GJ0533102	Resistor 330Ω 2W ±5%
RH14	1	1	GJ0533102	Resistor 330Ω 2W ±5%
RH15	1	1	GJ0515101	Resistor 150Ω 1W ±5%
RH16	1	1	GJ0515101	Resistor 150Ω 1W ±5%
PH01 CAPACITORS				
CH01	1	1	DD1620103	Ceramic Cap 200PF ±10%
CH02	1	1	DD1620103	Ceramic Cap 200PF ±10%
CH03	1	1	DF1627305	Film Cap 0.027μF 50V ±10%
CH04	1	1	DF1627305	Film Cap 0.027μF 50V ±10%
CH05	1	1	DF1647305	Film Cap 0.047μF 50V ±10%
CH06	1	1	DF1647305	Film Cap 0.047μF 50V ±10%
CH07	1	1	DF1610305	Film Cap 0.01μF 50V ±10%
CH08	1	1	DF1610305	Film Cap 0.01μF 50V ±10%
PH01 PLUGS				
JH01 ~ JH20	20	20	YP1000113	Plug
SH01	1	1	SP0405012	Push SW
PT01 MONITOR DOLBY BOARD				
PT01	1	1	YD2916004	P.W. Board Monitor Dolby MONITOR DOLBY(HB)
	1	1	ZZ2916004	P.W. Board Assembly
PH01 RESISTORS & CAPACITORS				
RT01	1	1	RT0510214	Resistor 1KΩ ¼W ±5%
RT02	1	1	RT0510214	Resistor 1KΩ ¼W ±5%
CT01	1	1	DF1522205	Film Cap 0.002μF 50V ±5%
CT02	1	1	DF1522205	Film Cap 0.002μF 50V ±5%
PH01 SWITCH				
ST01	1	1	SP0605007	Push SW
PH01 PLUGS				
JT01 ~ JT23	23	23	YP1000113	Plug
R003	1	1	RC1047012	Resistor 47Ω ¼W ±10%
0831	1	1	291510901	Shield
0832	1	1	288912005	Insulator
1303	1	1	285310650	Bearing K

REF. DESIG.	U	E	PART NO.	DESCRIPTION
1308	1	1	51640410D	Set Screw CP
1309	1	1	54040402N	Spring Washer
1310	1	1	53110403E	Hexagon Nut
0503	1		291616001	Bracket
0505	1	1	291616022	Bracket
0513	1		145525903	Bush
0514	1	1	284906702	Cap
0516	1		282125901	Bush
0517	2		55060305S	TR Rivet
0518	2		54050300R	TL Washer OR
0519	2		51060316A	P H M Screw P 3 x 16
0520	2		53110303A	Hexagon Nut
0523	4	4	51100308S	B H M Screw B 3 x 8
0524	4	4	53110303A	Hexagon Nut
0525	4	4	54050300R	TL Washer OR
0530	1	1	54050400R	TL Washer OR
0533	4	4	51100306S	B H M Screw B 3 x 6
0534	4	4	53110303A	Hexagon Nut
0602	8	8	51100306S	B H M Screw B 3 x 6
0603	8	8	53110303A	Hexagon Nut
0606	2	2	51100306S	B H M Screw B 3 x 6
0616	1	1	145525903	Bush
0620	3	3	51100306S	B H M Screw B 3 x 6
J001	1	1	YT0101003	Terminal GRAND
J002	1	1	YT0201009	Terminal QUAD OUT 1P
J003	1	1	YT0204008	Terminal PHONO ANX 4P
J004	1	1	YT0208006	Terminal TAPE 8P
J014	1	1	YT0304006	Terminal
J020	1		YJ0800012	Socket FUSE HOLDER
J021	1		YJ0400048	Socket AC OUTLET
J022	1		YJ0400048	Socket AC OUTLET
G001	1		BF1040002	Printed Comp
F001	1		FS1040005	Fuse
W001	1		YC0240010	AC Cord
C001	1	1	DK1810301	Ceramic Cap 0.01μF 50V
C007	1	1	DK1810301	Ceramic Cap 0.01μF 50V
C006	1	1	DK1810301	Ceramic Cap 0.01μF 50V
2610	1	1	62030039W	Lug
J010	1	1	YT0204009	Terminal PRE-MAIN
R005	1	1	RC1022512	Resistor 2.2MΩ ¼W ±10%
8236	1	1	62030039W	Lug
J015	1	1	YT0304006	Terminal REMOTE SP
PU01 ANT, MUTING BOARD				
PU01	1	1	YD2916007	P.W. Board Ant. Muting
	1	1	ZZ2916007	P.W. Board Assembly
RU04	1	1	RK0203032	Variable Res. 20K (B)
RU05	1	1	RK0503010	Variable Res. 50K (B)
R004	1	1	RT0543214	Resistor 4.3KΩ ¼W ±5%
LU01	1	1	LB3007526	Balan Coil
LU02	1	1	LC1154002	Choke Coil
JU01	1	1	YT0304009	Terminal
JU02	1	1	YT0304009	Terminal
~ JU07	6	6	YP1000113	Plug
0605	1	1	291616005	Bracket
L001	1	1	LF1120038	ANT Coil AM ANT

REF. DESIG.	U	E	PART NO.	DESCRIPTION
L002	1	1	LC1332002	Choke Coil 3.3μH
0705	1	1	281927103	Holder
0706	1	1	257816052	Bracket K
0711	2		51100310S	B H M Screw B 3 x 10
0712	2	2	54050300R	T L Washer OR
0713	2	2	53110303E	Hexagon Nut
0716	2	2	51100310S	B H M Screw B 3 x 10
0718	2	2	53110303E	Hexagon Nut
0528	1	1	62041760W	Lug
H007	1	1	HD2000510	Diode 5B2
L003	1	1	LC1332002	Choke Coil 3.3μH
C002	1	1	DK1840301	Ceramic Cap 0.04μF 50V
J007	1	1	YL0103018	Terminal 3P
1728	1	1	138200503	Clamper
2705	2	2	138200503	Clamper
2716	1	1	121000501	Clamper
2415	1	1	285416003	Bracket
2416	2	2	51570305B	P H Tapt Screw P 3 x 5 ST
2418	2	2	51100306S	B H M Screw B 3 x 6
0622	1	1	51100306S	B H M Screw B 3 x 6
0623	1	1	51100308S	B H M Screw B 3 x 8
0624	1	1	53110303A	Hexagon Nut
0625	1	1	54050300R	T L Washer OR
2403	1	1	289016008	Bracket
2404	1	1	285412001	Insulator
2405	4	4	51100310A	B H M Screw B 3 x 10
2406	5	5	54060300R	T L Washer IR
0221	4	4	275905701	Leg
0222	4	4	51490410S	B H M Screw F S
0430	1	1	288686101	Label
0510	6	6	51100306S	B H M Screw B 3 x 6
0907	10	10	51570306B	P H Tapt Screw P 3 x 6 ST
1707	1	1	288910903	Shield
1708	2	2	51100306S	B H M Screw B 3 x 6
1713	4	4	51570306B	P H Tapt Screw P 3 x 6 ST
1715	2	2	288912006	Insulator
1716	1	1	54020301E	Flat Washer
2008	8	8	51570306B	P H Tapt Screw P 3 x 6 ST
2034	1	1	291610903	Shield
2035	3	3	51570306B	P H Tapt Screw P 3 x 6 ST
2107	1	1	51570306S	P H Tapt Screw P 3 x 6 ST
2109	3	3	51100306S	B H M Screw B 3 x 6
2114	4	4	51570308B	P H Tapt Screw P 3 x 8 ST
2115	1	1	291616006	Bracket
2116	1	1	51570408B	P H Tapt Screw P 4 x 8 ST
2117	2	2	51570310B	P H Tapt Screw P 3 x 10 ST
2118	2	2	54040302N	Spring Washer
2128	4	4	51490512A	B H M Screw FS
2129	4	4	53110501A	Hexagon Nut
2130	4	4	54020501A	Flat Washer
2203	1	1	285610902	Shield
2204	4	4	285610102	Support
2205	1	1	281810107	Support
2206	3	3	51060304E	P H M Screw P 3 x 4
2207	2	2	50020305B	R H M Screw
2208	2	2	59030805P	Washer
2213	4	4	51100306S	B H M Screw B 3 x 6
2303	4	4	288810102	Support
2305	1	1	291610902	Shield
2306	4	4	51100304S	B H M Screw B 3 x 4
2313	2	2	288810102	Support
2314	2	2	51100306S	B H M Screw B 3 x 6

REF. DESIG.	U	E	PART NO.	DESCRIPTION
2316	1	1	291610901	Shield
2317	2	2	51100304S	B H M Screw B 3 x 4
2323	2	2	291610101	Support
2324	2	2	51100304S	B H M Screw B 3 x 4
2425	1	1	138200503	Clamper
2428	1	1	51570306B	P H Tapt Screw P 3 x 6 ST
2429	1	1	54050300R	T L Washer OR
2432	1	1	121000501	Clamper
2433	1	1	51570306B	P H Tapt Screw P 3 x 6 ST
2434	1	1	54050300R	T L Washer OR
2503	1	1	291710550	Chassis K
2513	5	5	288600502	Clamper
2514	3	3	288600506	Clamper
2515	2	2	288600505	Clamper
2519	2	2	291616007	Bracket
2521	2	2	285310102	Support
2522	2	2	54040402N	Spring Washer
2530	2	2	288925901	Bush
2532	1	1	281805603	Buffer
2607	3	3	51570306B	P H Tapt Screw P 3 x 6 ST
2611	1	1	51570306B	P H Tapt Screw P 3 x 6 ST
2615	1	1	51570306B	P H Tapt Screw P 3 x 6 ST
0451	1	1	62030039W	Lug
2706	2	2	51570306B	P H Tapt Screw P 3 x 6 ST
2709	1	1	121000501	Clamper
2710	1	1	51570306B	P H Tapt Screw P 3 x 6 ST
C004	1	1	EC1090502	Electroly Cap 10000μF 50V
C005	1	1	EC1090502	Electroly Cap 10000μF 50V
L004	1	1	TS6050208	Trans
L004	1	1	TS6050209	Trans
0115	4	4	52017039J	Bolt
0120	1	1	291605501	Collar
0203	1	1	291625701	Lid
0204	5	5	257711807	Spacer
0205	4	4	285605601	Buffer
0207	4	4	51480406S	B H M Screw F
0213	1	1	291625702	Lid
0214	1	1	291512001	Insulator
0215	1	1	250712001	Insulator
0216	10	10	51100406S	B H M Screw B 4 x 6
0303	1	1	290415404	Knob POWER SW
0304	1	1	285015401	Knob SLIDE VOL
0305	10	10	288615403	Knob PUSH SW
0307	2	2	281815403	Knob
0402	1	1	291626501	Indicator
0404	1	1	291626503	Indicator
0410	2	2	51100305S	B H M Screw
0411	1	1	257886101	Label UL CAUTION
0412	1	1	257886102	Label DO NOT REMOVE--
0413	1	1	257886103	Label SEE MARKING
0414	1	1	250626505	Indicator DO NOT USE AS--
0421	1	1	951091102	Label UL Factory NO
0424	1	1	951110102	Label UL
0819	1	1	289610701	Sheet HEAD PHONE
0823	2	2	289610701	Sheet DUBBING
1410	1	1	285011202	Shaft
1411	1	1	54040402N	Spring Washer
1612	1	1	291526901	Protector
1613	2	2	51570305B	P H Tapt Screw P 3 x 5 ST
1615	2	2	287105302	Cover
1618	1	1	286726901	Protector
1619	2	2	51100306S	B H M Screw B 3 x 6

U: For U.S.A.
E: For Europe

REF. DESIG.	U	E	PART NO.	DESCRIPTION
1910	1	1	56382540G	Eyelet
2802	1		291685101	Instructions Set
2803		1	291685121	Instructions Set
2809	1		291685601	Schematic
2810		1	291685602	Schematic
2814	1	1	281885708	Instructions Accessories
2817	1	1	281885104	Instructions Packing
2819	1	1	281885110	Instructions 4 ch
2824	1	1	257785401	Guarantee Card
2825	1	1	257785102	Instructions Red Card
2826	1		257781301	Envelope
2831		1	281881301	Envelope
2902	1	1	291680101	Packing Case Inner
2903	1	1	291680111	Packing Case Outer
2908	1	1	288680302	Partitioner Upper
2909	1	1	288680303	Partitioner Lower
2912	1	1	901483838	Polyethylene Bag Set
2914	1	1	901302501	Polyethylene Bag Printed Materials
2915	1	1	901302501	Polyethylene Bag Accessories
2917	1	1	102980401	Sleeve Power Cord
2918		1	956000004	Hang Tag
2919	2	2	273182101	Silicagel
2920	1	1	281905601	Buffer
2922	4		952281501	Serial No Card
2924		4	952301511	Serial No Card
2931	1	1	ZA0200007	Ext Antenna FM Antenna
PR01		1	YD2871003 ZZ2871803	P W Board,Fuse P W Board Assembly
				PR01 JACKS
JR01 ~ JR08		8	YJ0800020	Jack
JR09 ~ JR16		8	YP1000099	Jack

SPECIFICATIONS

AUDIO CIRCUITS:

Rated Power Output	
(Continuous average per channel, all channels driven)	
Power Output	45 Watts at 4 ohms 40 Watts at 8 ohms 20 Watts at 16 ohms
Power Band	20 Hz to 20 KHz
THD	0.3%
High-level hum and noise (ref. 40W at 8 ohms)	-60 dB
Phono hum and noise	1.5 μ V equivalent Input
Dynamic range (phono input to tape recording output)	90 dB
I. M. Distortion (SMPTE), at rated power	0.3%
Distortion decreases as output is lowered	
Total Harmonic Distortion, at rated power	0.3% Maximum
Distortion decreases as output is lowered	
Damping Factor (ref. 8 ohms)	Greater than 30
Frequency Response	
Through phono	\pm 2 dB
Input Sensitivity (for 40W at 8 ohms)	
High-level	180 mV
Phono (1,000 Hz)	1.8 mV
High-level	100,000 ohms
Phono	47,000 ohms
Channel Separation 20 Hz to 10,000 Hz	30 dB Minimum

FM SECTIONS:

IHF Usable Sensitivity	2.3 μ V
Selectivity	60 dB
Noise Quieting	-55 dB at 5 μ V -60 dB at 10 μ V -65 dB at 50 μ V
Total Harmonic Distortion, 400 Hz, 100% Mod.	(Mono) 0.2% (Stereo) 0.4%
Frequency Response (ref. 50 μ sec. de-emphasis)	\pm 1 dB 50 Hz to 15 KHz
Stereo Separation	1,000 Hz 40 dB
Sub-Carrier (38 kHz) Suppression	60 dB

GENERAL:

Power Requirements	220V ~ 50/60 Hz
(This unit can be converted by a qualified technician to operate on 110/120/240V ~ 50/60 Hz)	
At rated output, both channels operating	170 Watts
Idling Power (Volume Control at zero)	30 Watts
Dimensions	
Panel Width	17-3/8 Inches
Panel Height	5-3/8 Inches
Depth	14-3/8 Inches
Weight	
Unit alone	30.8 lbs
Packed for shipment	38.1 lbs

*These specifications and exterior designs may be changed for improvement without advance notice.

SERVICE INFORMATION FOR EUROPEAN MODEL

The information contained here in includes the rear panel and main chassis component locations, schematic diagram, voltage conversion and FTZ regulation.

For the circuit description, alignment method and repairing hints, refer to the original service manual.

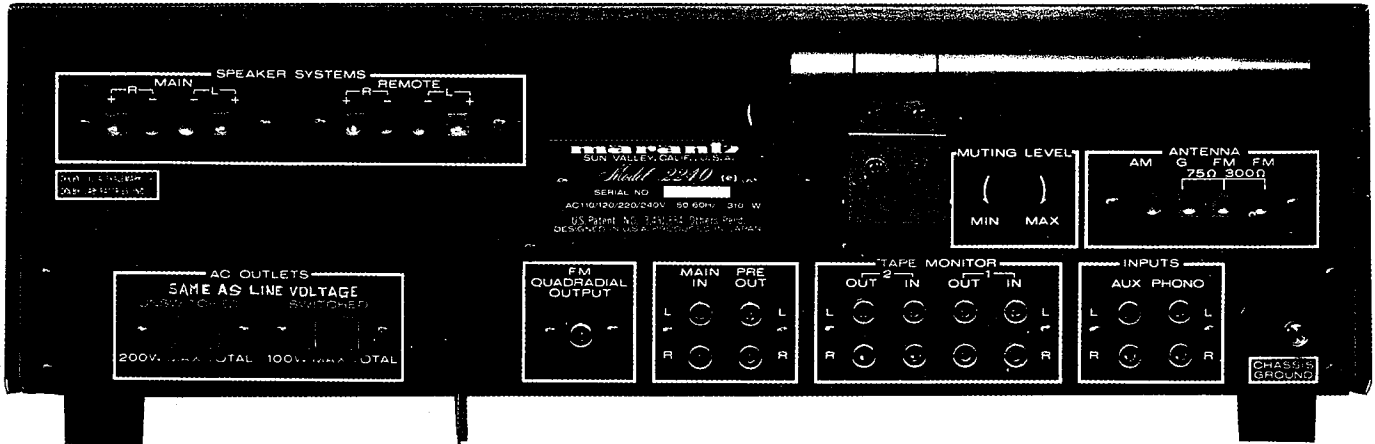

W001

Figure 24. Rear Panel Adjustment and Component Locations

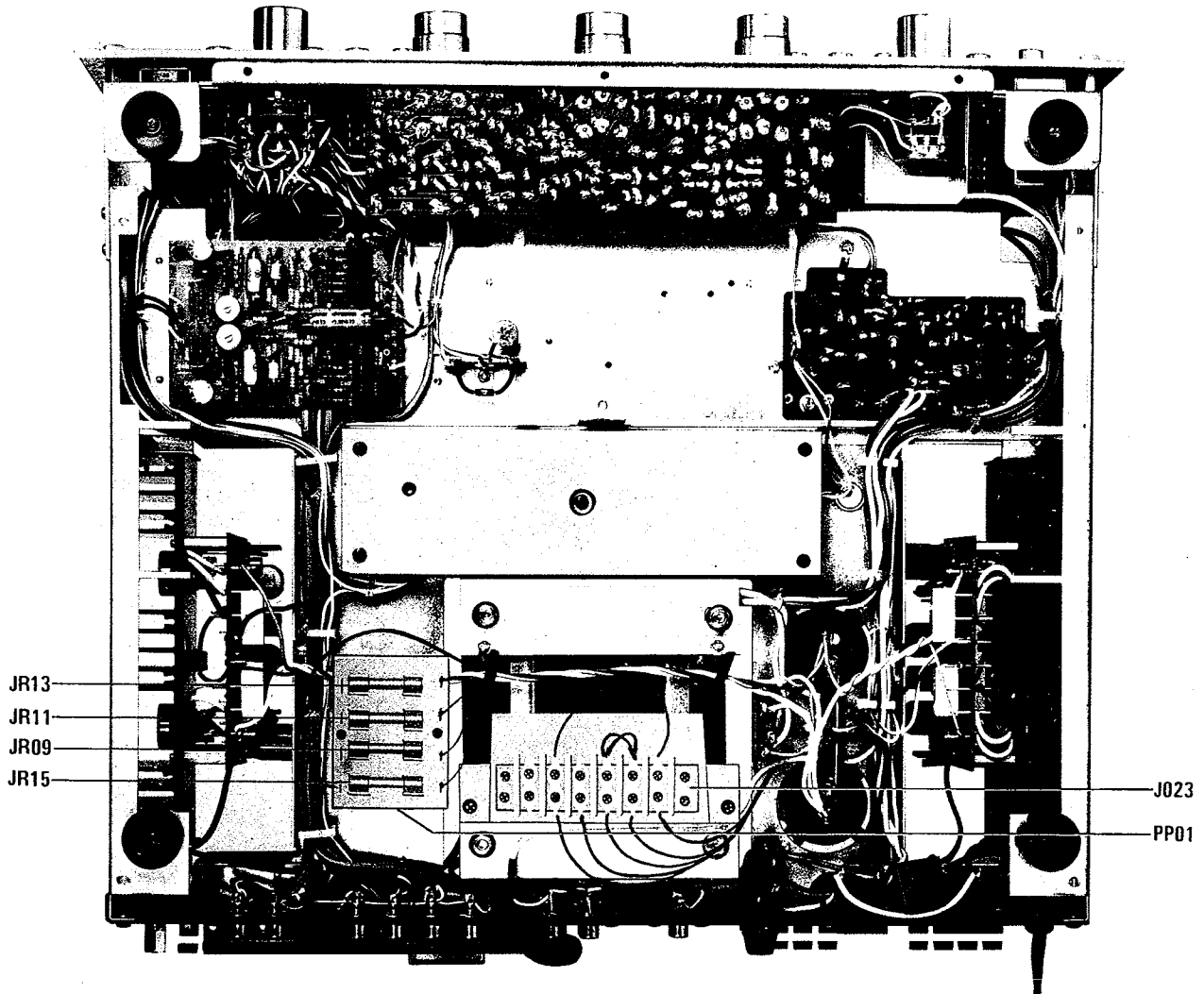

Figure 25. Main Chassis Component Locations (Bottom View)

VOLTAGE CONVERSION

This model is equipped with a universal power transformer to permit operation at 110, 120, 220 and 240V AC 50 to 60Hz.

To convert the unit to the required voltage perform the following steps:

- (1) Remove the cover.
- (2) Change the jumper wires as illustrated below for the required AC voltage.

CAUTION: DISCONNECT POWER SUPPLY CORD FROM AC OUTLET BEFORE CONVERTING VOLTAGE.

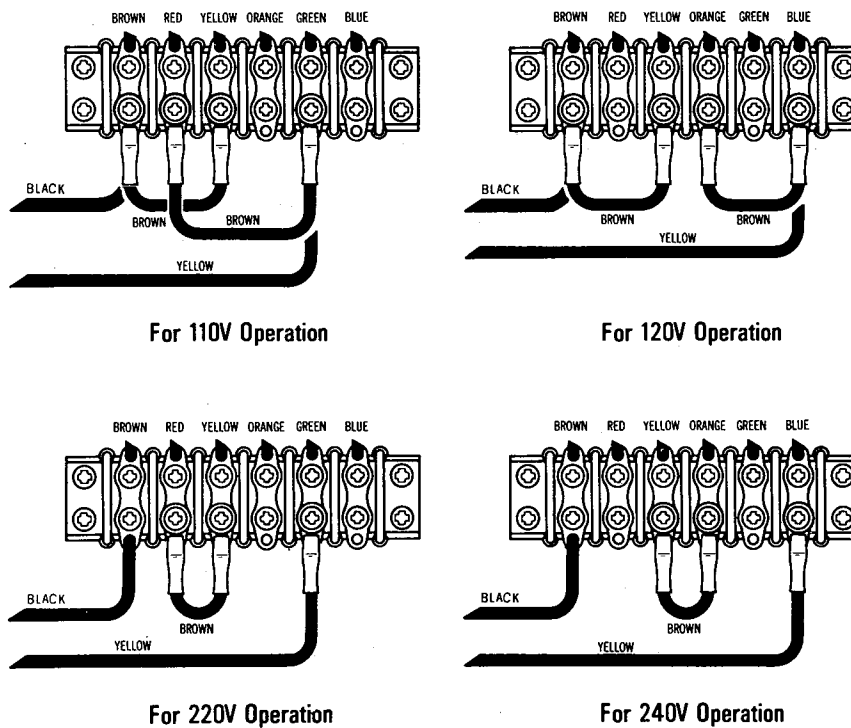

Figure 26. Voltage Conversion Chart

FTZ REGULATION

Instruction for the use in the range other than specified in FTZ codes

**Achtung für die Leute, die in dem Gebiet wohnen,
wo die FTZ-Bestimmungen vorherrschend sind.**

Sollte das Gerät auch für Frequenzen ausserhalb des in den FTZ-Bestimmungen angegebenen Bereiches empfangsbereit sein, bitten wir, den Bereich durch Nachstellen des Kernes in der Oszillatorschleife (in der Abbildung mit "FTZ" gekennzeichnet) so zu korrigieren, dass er den Bestimmungen entspricht.

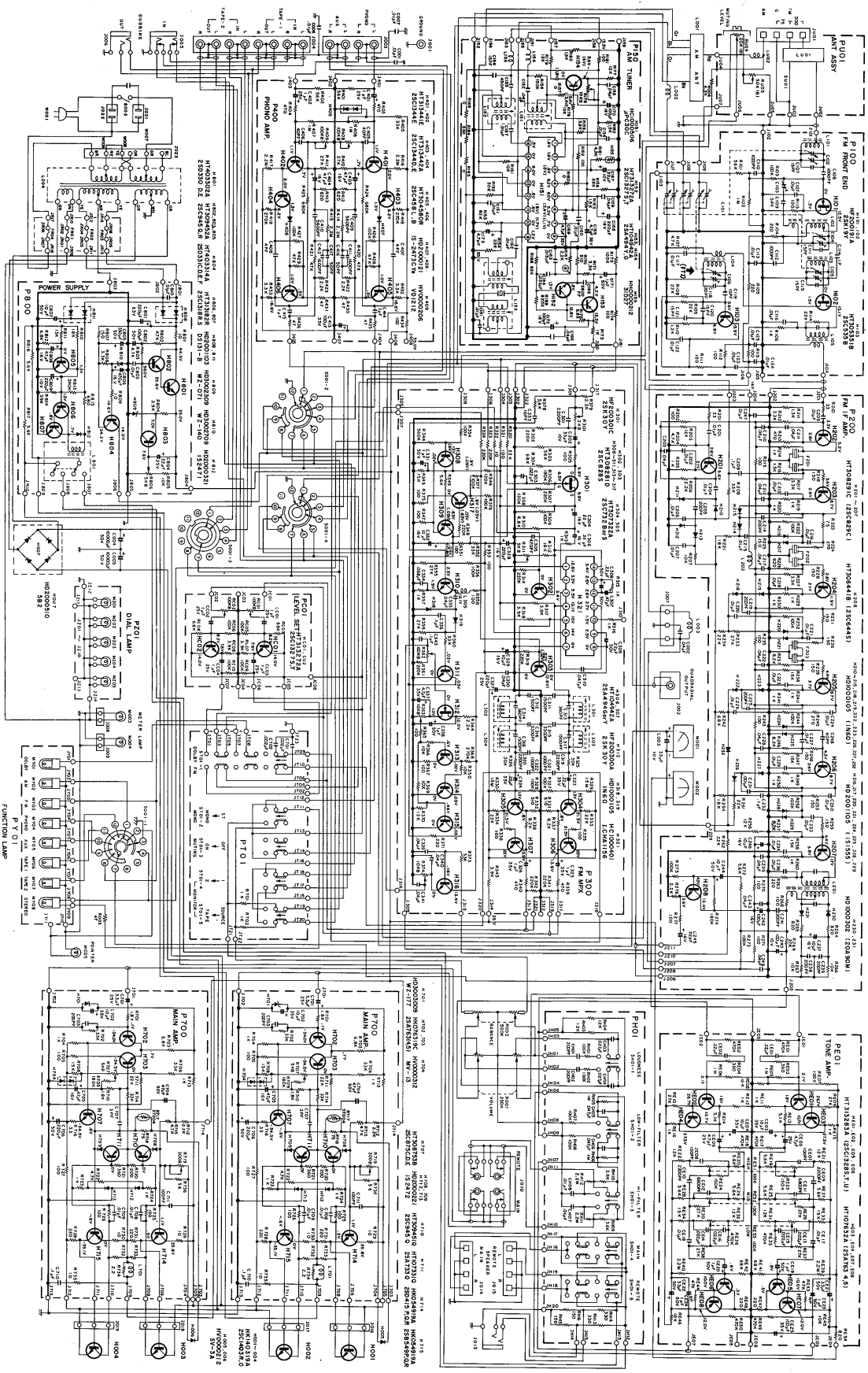

MODEL 2240

NOTE: This schematic diagram applied to units manufactured for the European market.

Values shown are measured by using a VTVM at the output.
 Values in / are measured by limit input signal in the STEREO mode.

Figure 27. Schematic Diagram for European Model



marantz

MARANTZ CO., INC. · P. O. BOX 99 · SUN VALLEY, CALIFORNIA · 91352



A WHOLLY-OWNED SUBSIDIARY OF SUPERSCOPE INC., SUN VALLEY, CALIFORNIA 91352