

**HiFi ENGINE®**

For more Hi-Fi manuals and set-up information  
please visit [www.hifiengine.com](http://www.hifiengine.com)

SERVICE  
MANUAL **140**

**marantz**

model 140

*Stereo Power Amplifier*

## TABLE OF CONTENTS

SECTION	PAGE
Introduction . . . . .	1
Test Equipment Required for Servicing . . . . .	1
Alignment Procedure . . . . .	2
Technical Specifications for U.S.A. Model . . . . .	14
Parts List . . . . .	15
Service Information for European Model . . . . .	19
Technical Specifications for European Model . . . . .	19

## LIST OF ILLUSTRATIONS

FIGURE	PAGE
1. Block Diagram of M140 . . . . .	3
2. Wiring Diagram of M140 . . . . .	4
3. Schematic Diagram of M140 . . . . .	5
4. Exploded Mechanical Diagram . . . . .	7
5. Front Panel Adjustment and Component Locations . . . . .	9
6. Main Chassis Component Locations (Top View) . . . . .	9
7. Rear Panel Jacks and Component Locations . . . . .	10
8. Main Amp. P700 Schematic Diagram and Component Locations . . . . .	11
9. Relay (PN00) Schematic Diagram and Component Locations . . . . .	12
10. Meter/Peak Ind. Schematic Diagram and Component Locations . . . . .	13
11. Repacking Illustration . . . . .	14
12. Rear Panel Adjustment and Component Locations for European Model . . . . .	20
13. Main Chassis Component Locations (Bottom View) for European Model . . . . .	20
14. Schematic Diagram for European Model . . . . .	21

## INTRODUCTION

This service manual is intended for use by authorized warranty stations. The manual contains service information for the Marantz Model 140 Stereo Power Amplifier, manufactured by the Marantz Company, a subsidiary of Superscope Incorporated, Sun Valley, California 91352.

Adjustment and maintenance listed herein should be attempted only by the experienced technician, one knowledgeable in solid state amplifier operation and the use of test equipment. All instructions should be read carefully and understood fully before proceeding with any service.

As the Marantz Company becomes aware of other field problems, supplementary service bulletins will be issued to all stations. To improve this service, all problems (and their solutions) not covered in this service manual should be brought to the attention of the National Service Manager at our Sun Valley location.

## TEST EQUIPMENT REQUIRED FOR SERVICING

Table 1 lists the test equipment required for servicing the Model 140 Stereo Power Amplifier.

Item	Manufacturer and Model No. (or equivalent)	Use
Distortion Analyzer	Hewlett Packard, Model 331 A or 333A	Measures distortion and voltage of amplifier output.
Audio Oscillator	Weston Model CVO-100P (NOTE: Less than 0.02 percent residual distortion is required.)	Sinewave and squarewave signal source.
Oscilloscope	Tektronix, Model 503; Data, Model 555	Waveform analysis and troubleshooting.
VTVM	RCA Senior Volt-Ohmyst, Model WV-98C	Voltage and resistance measurements.
AC Wattmeter	Simpson, Model 390	Monitors primary power consumption of amplifier.
Line Voltmeter (0 to 150 vac)	Commercial Grade	Monitors potential of primary power to amplifier.
Variable Autotransformer (0 to 140 vac, 10 amps)	Powerstat, Model 116B	Adjusts level of primary power to amplifier.
Shorting Plug	Use phono plug with 600 ohms across center pin and shell.	Shorts amplifier input to eliminate noise pickup.
Output Load Resistor (8 $\Omega$ $\pm$ 0.5%, 250 W)	Commercial Grade	Provides 8-ohm load for amplifier output termination.
Output Load Resistor (4 $\Omega$ $\pm$ 0.5%, 250 W)	Commercial Grade	Provides 4-ohm load for amplifier output termination.

## **ALIGNMENT PROCEDURE**

### **a. DC Balance**

1. Connect oscilloscope to Left Channel output terminals of the Model 140.
2. Turn Line Switch to ON and adjust variac to 120 vac.
3. After relay energizes, adjust Left Channel (Left Hand Heatsink) amplifier board potentiometer R741 for an indication of a "line" zero (i.e.,  $0V \pm 50 \text{ mV}$ ) as indicated on the oscilloscope.
4. Repeat for Right Channel (Right Hand Heatsink).

### **b. Bias Adjustment**

1. Preset the bias adjust potentiometer R742 on each amplifier board fully CCW.
2. Turn Line Switch to ON and slowly advance variac while observing the voltmeter and wattmeter. The relay LN01 should energize at 105 volts or less.
3. Connect Digital Voltmeter to J701 and J702.
4. Turn Line Switch to ON and advance variac to 120 volts.
5. Observe Digital Voltmeter reading. Adjust the Left Channel amplifier potentiometer R742 to increase Digital Voltmeter reading to 10mV above the initial reading.
6. Repeat for Right Channel (Right Hand Heatsink).

### **c. Meter Adjustment**

1. Preset RX03 and RX07 of both channels to CCW (Anti-clockwise direction).
2. Set the output of the speaker terminal to 9V R.M.S.
3. Set the meters (M001, M002) to "0VU" by RX07.
4. Increase the output of the speaker terminal to 16V R.M.S.  
Turn RX03 in the clockwise direction and stop where the meter's pointer hits the full scale stopper.

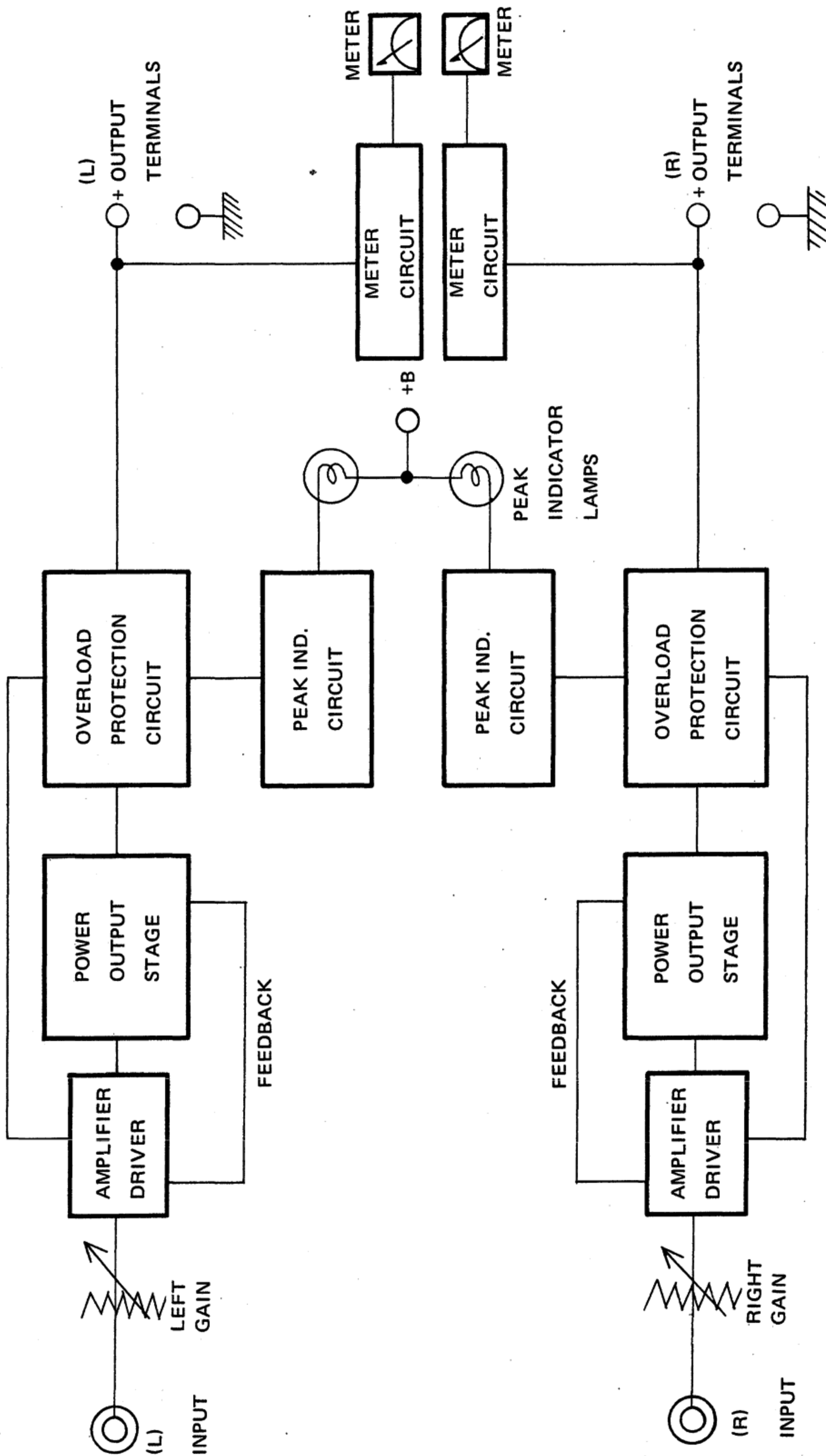

Figure 1. Block Diagram of M140

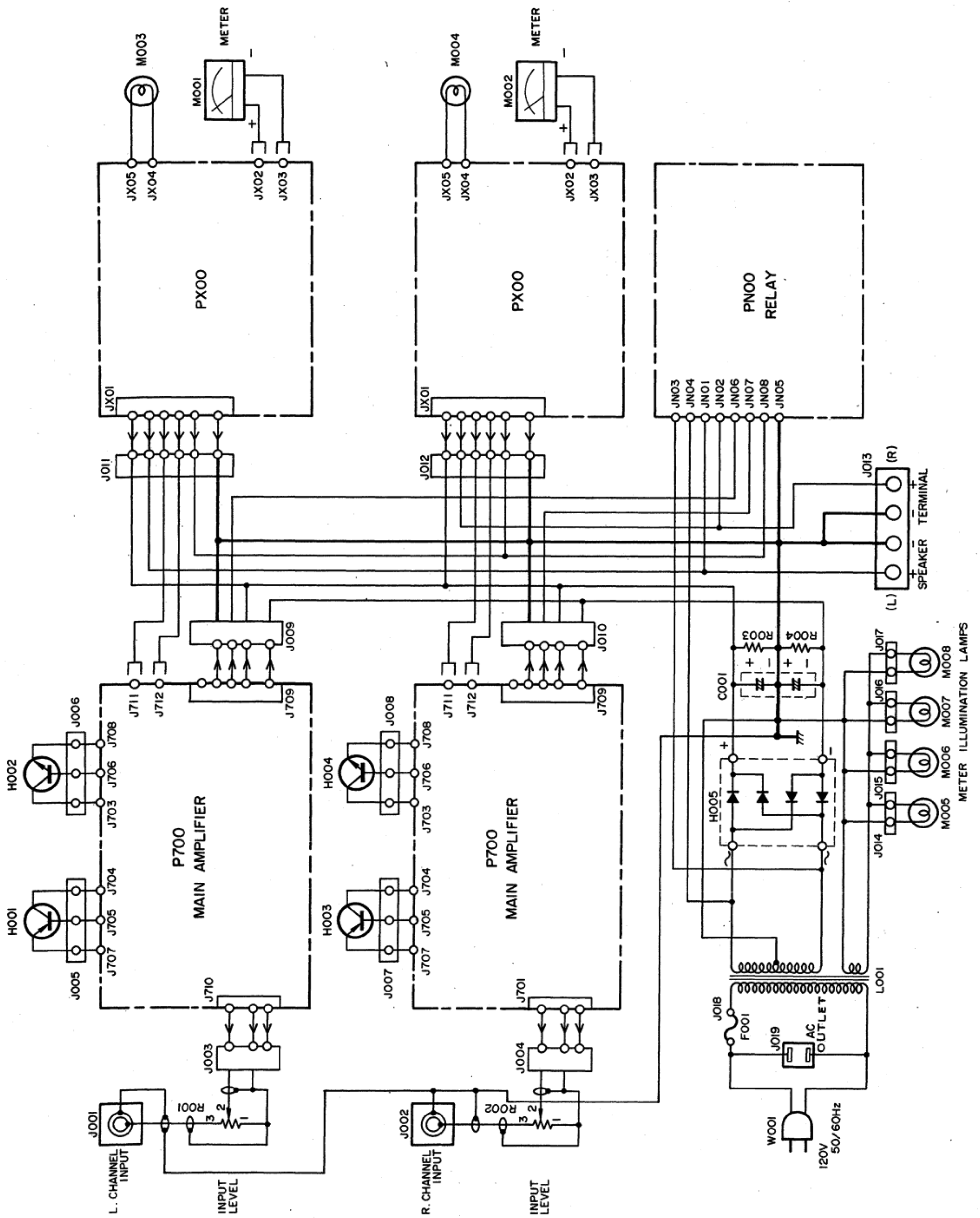
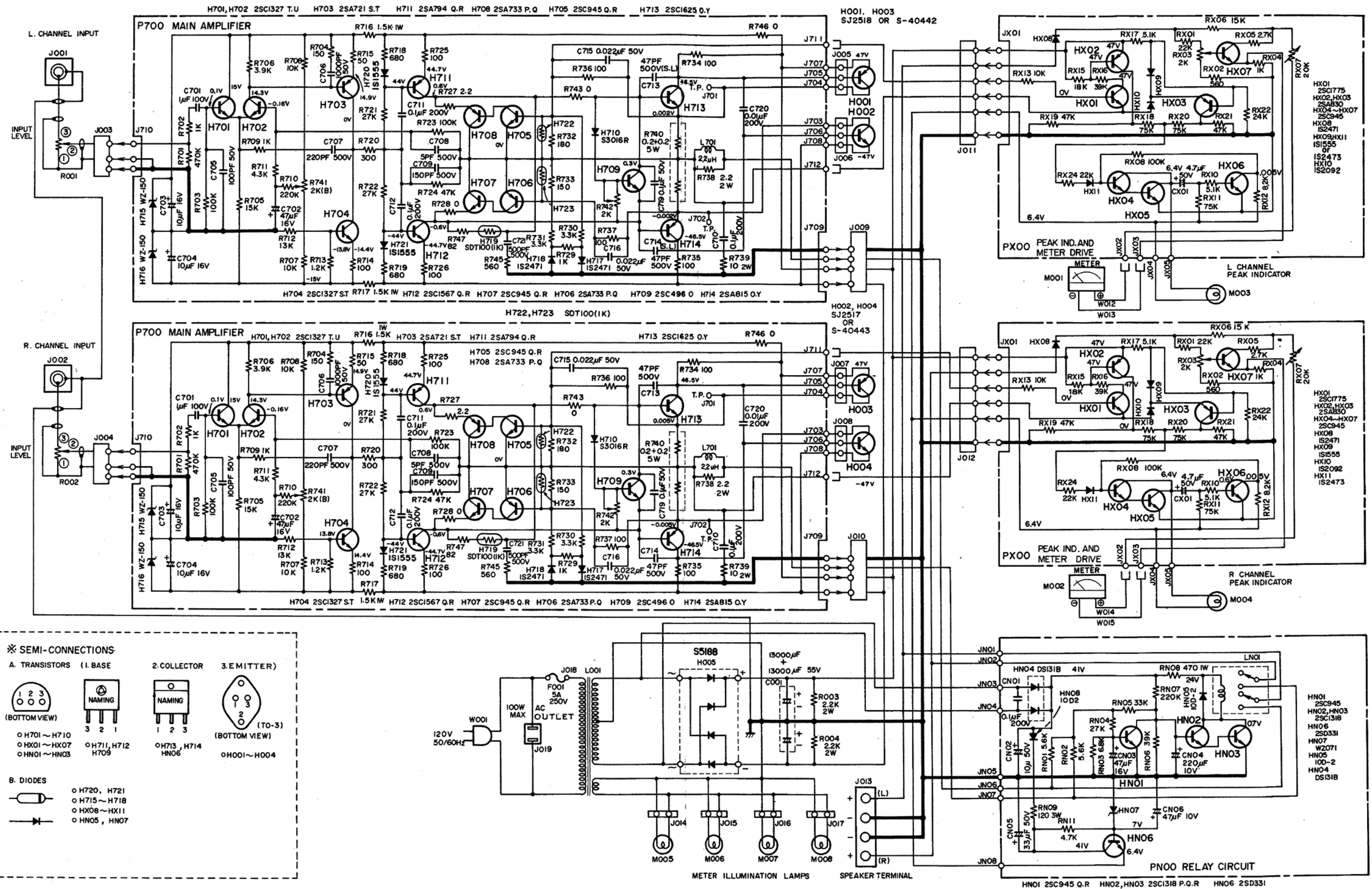

Figure 2. Wiring Diagram of M140







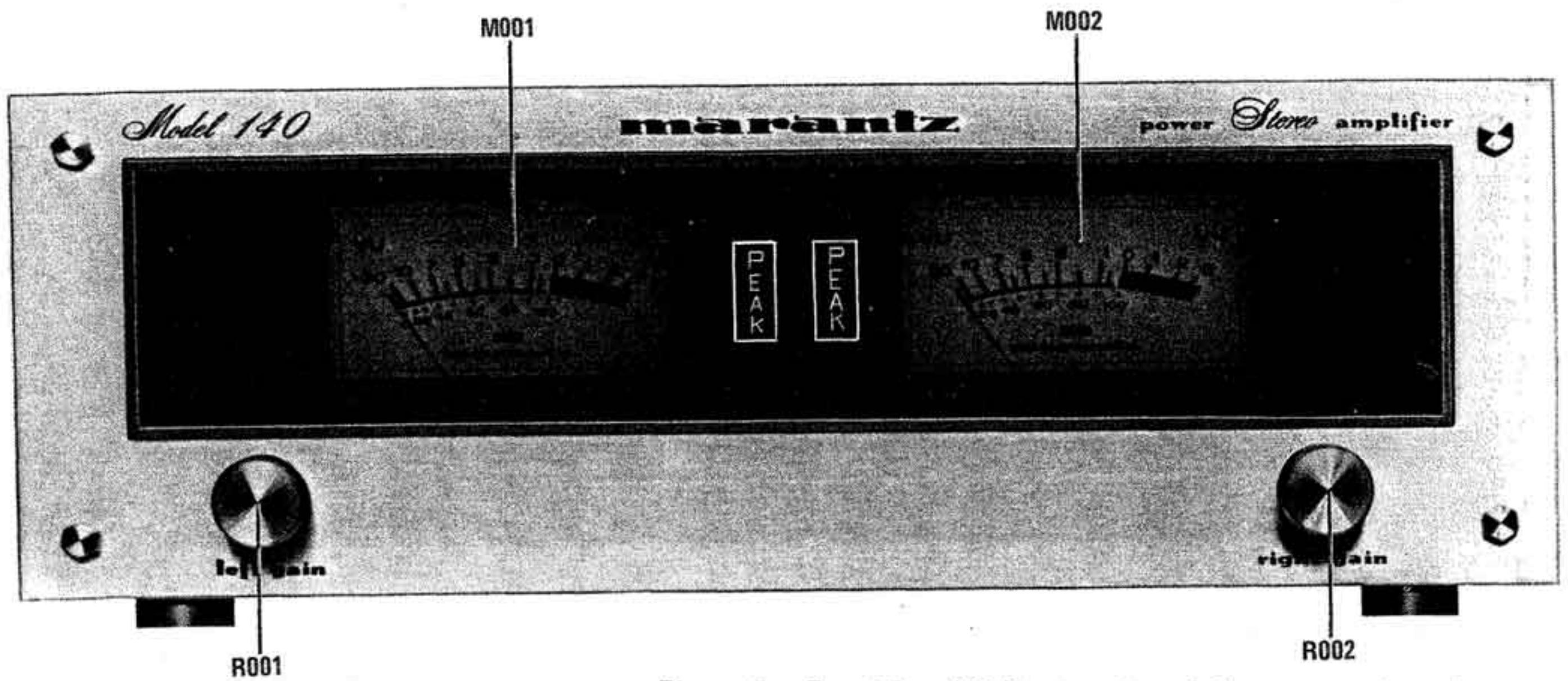

Figure 5. Front Panel Adjustment and Component Locations

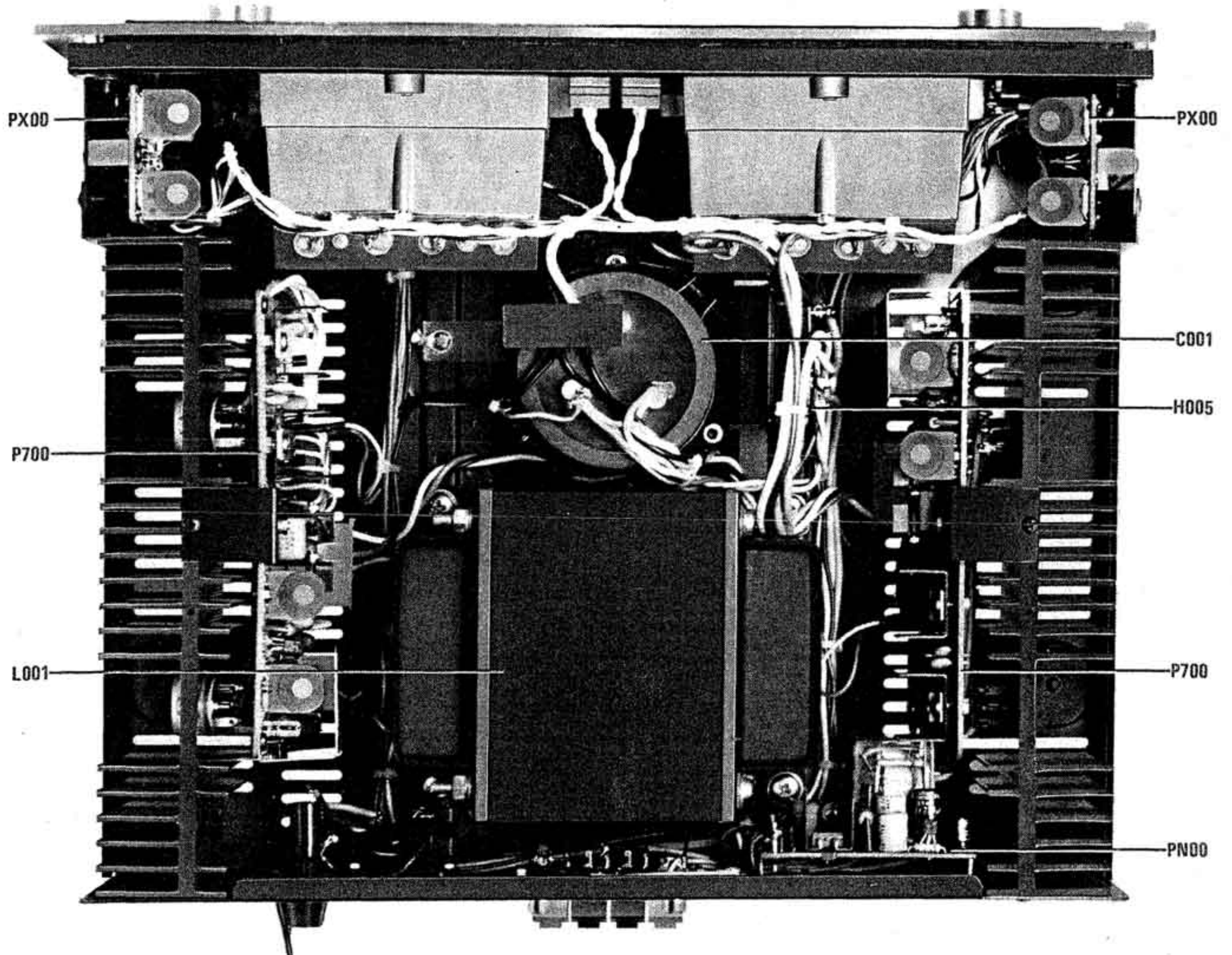

Figure 6. Main Chassis Component Locations (Top View)

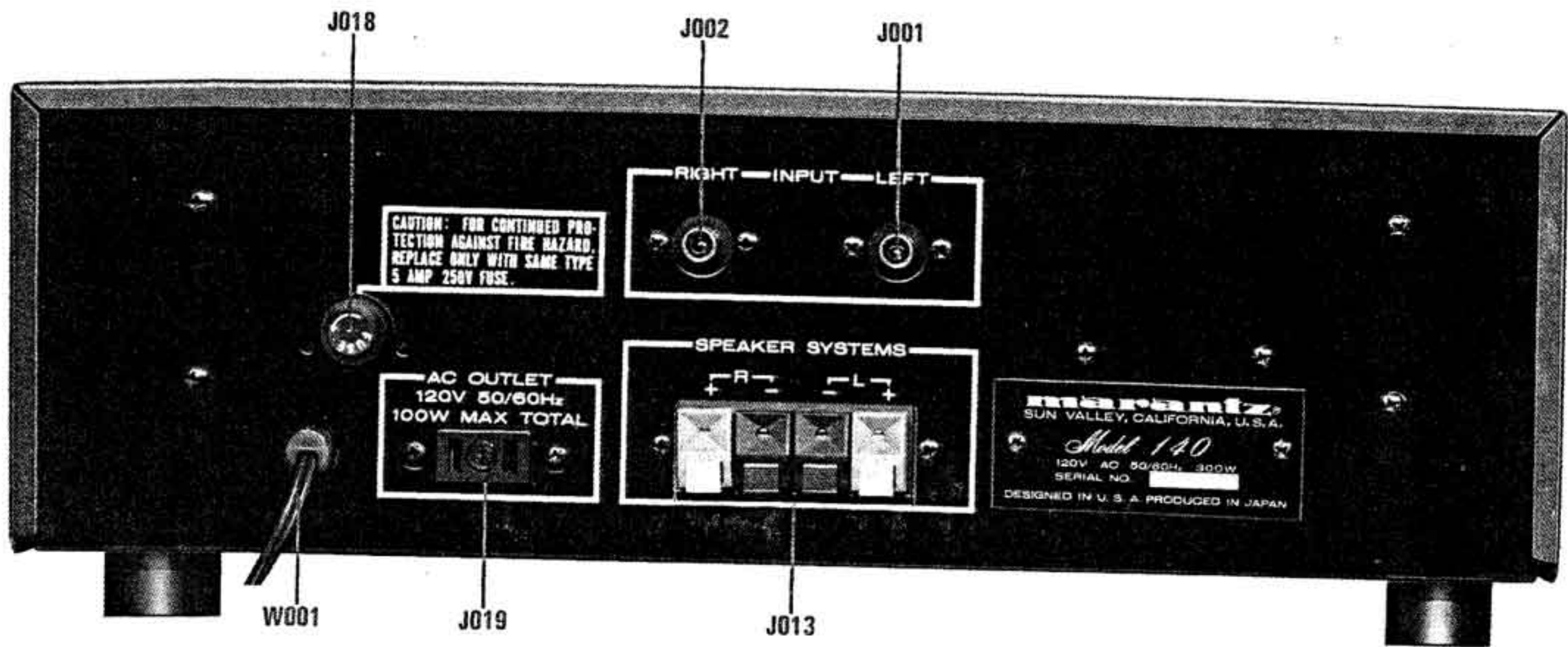

Figure 7. Rear Panel Jacks and Component Locations

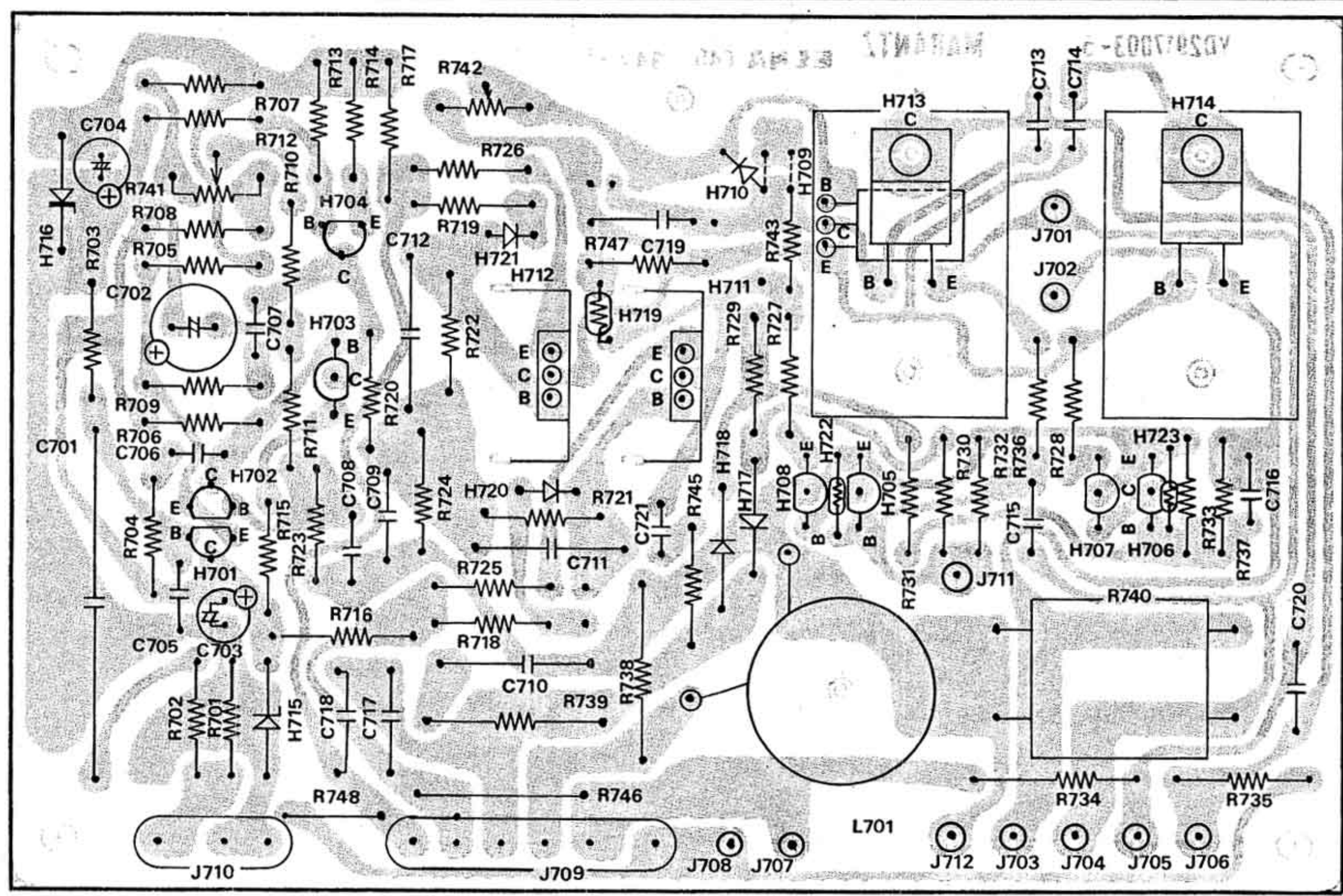
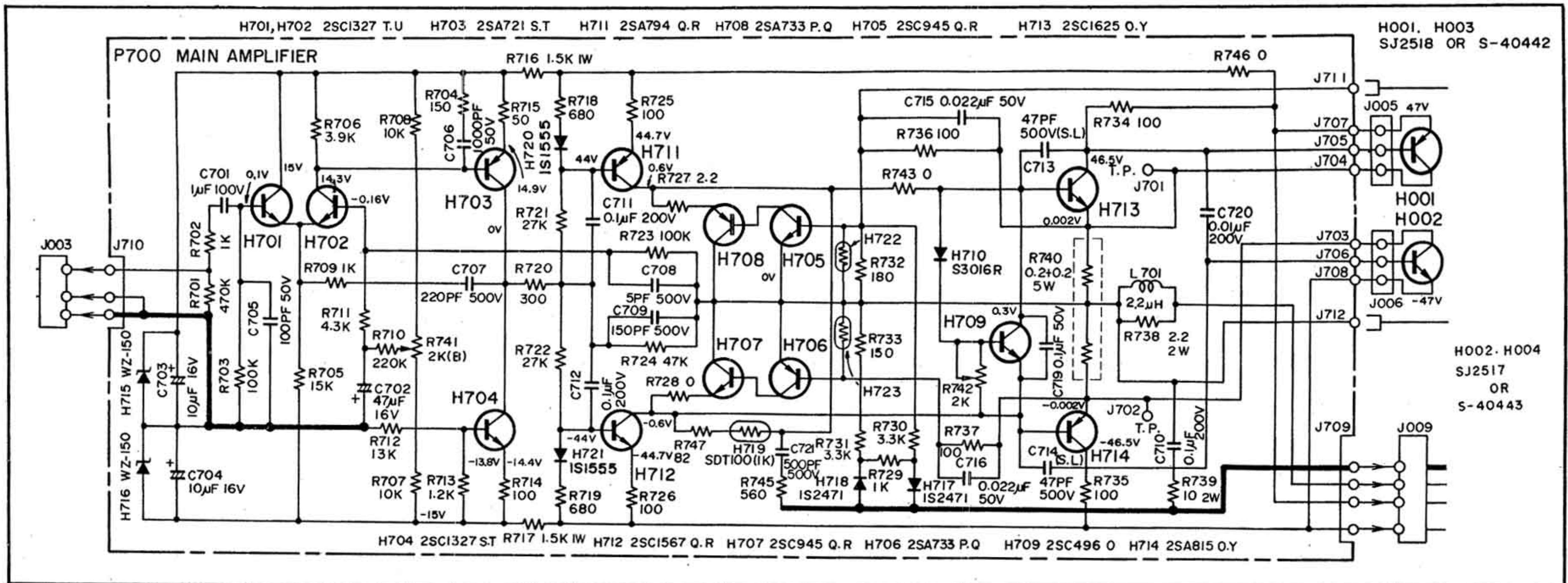
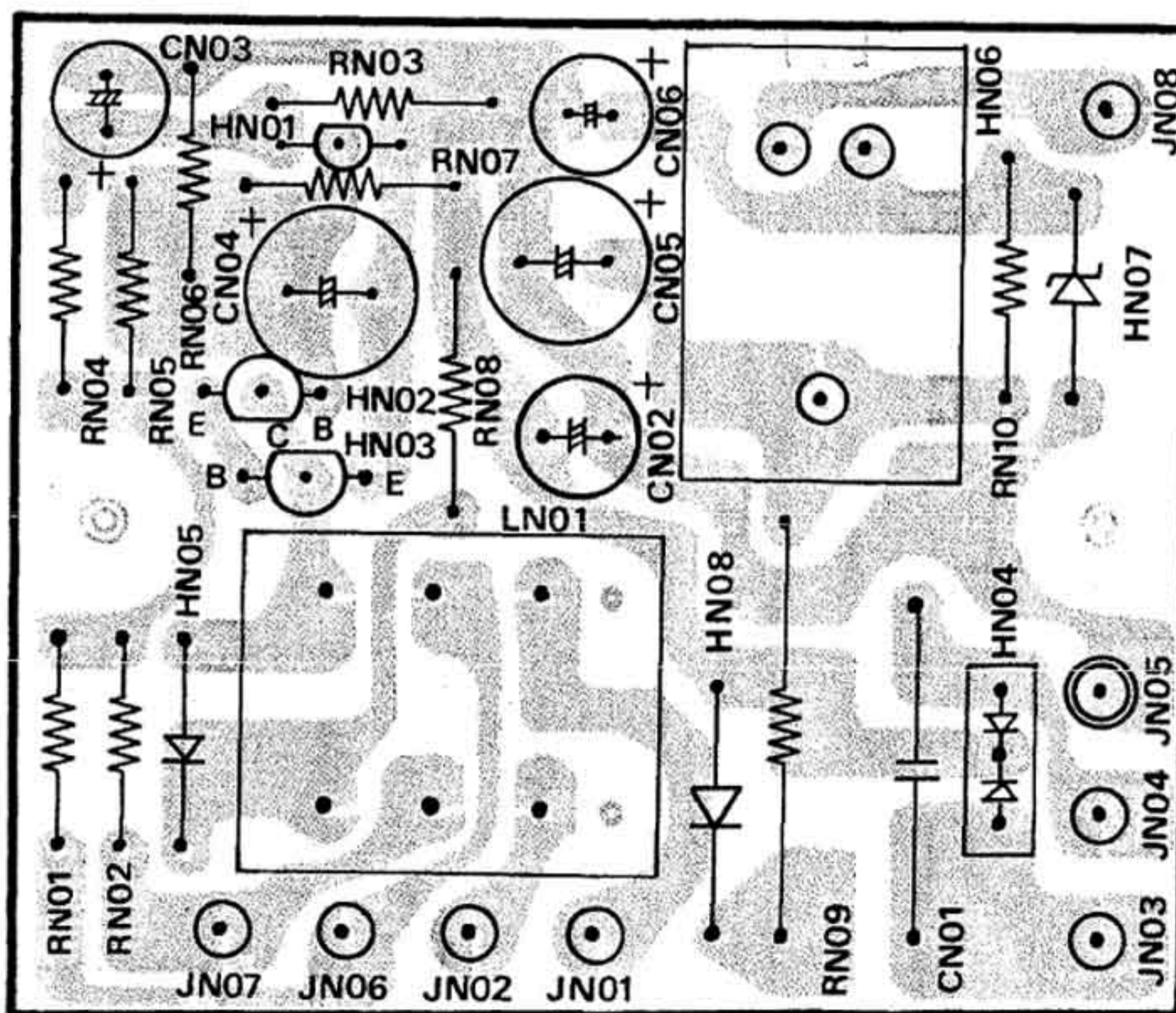
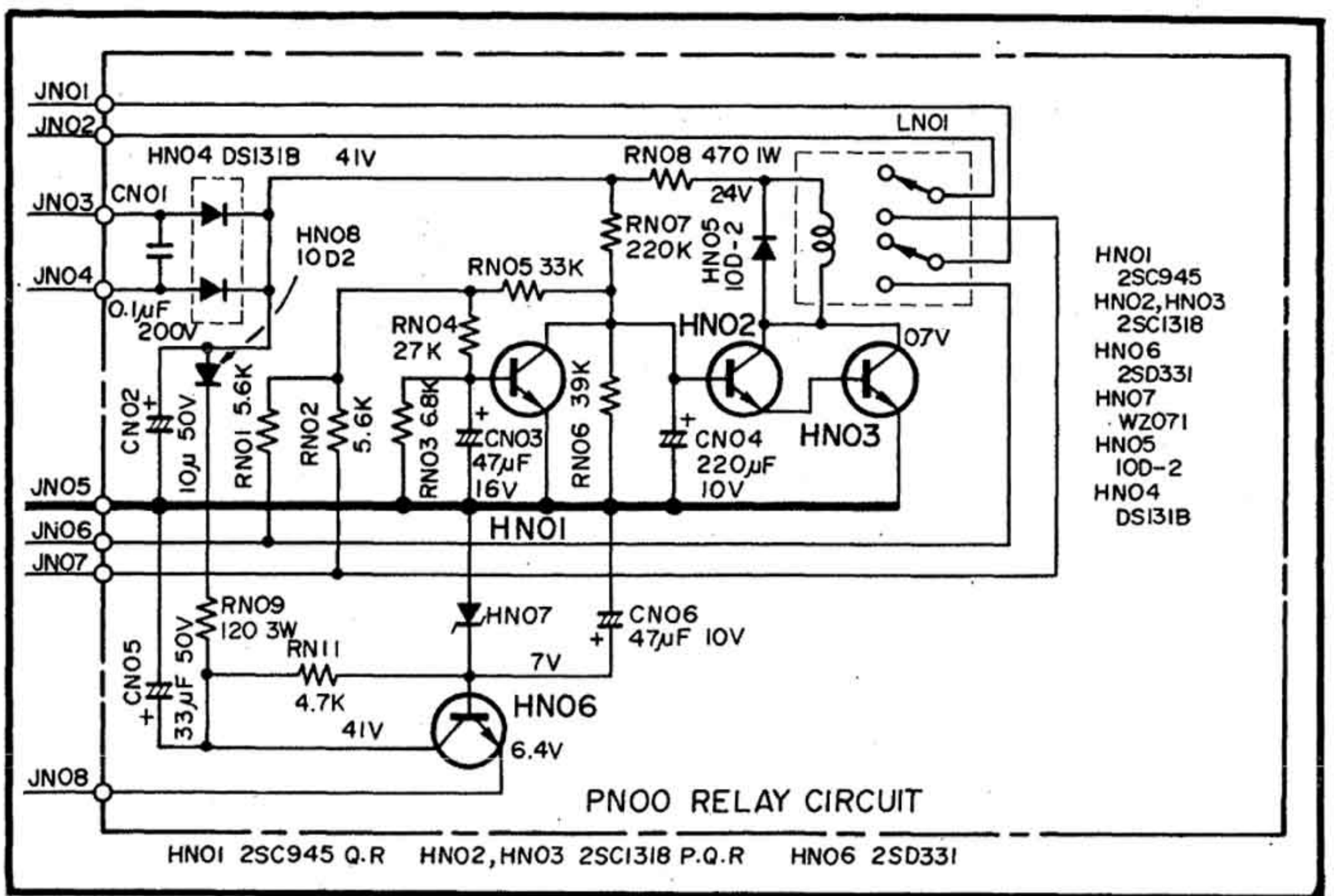

Figure 8. Main Amp. P700 Schematic Diagram and Component Locations



**Figure 9. Relay (PNO0) Schematic Diagram and Component Locations**

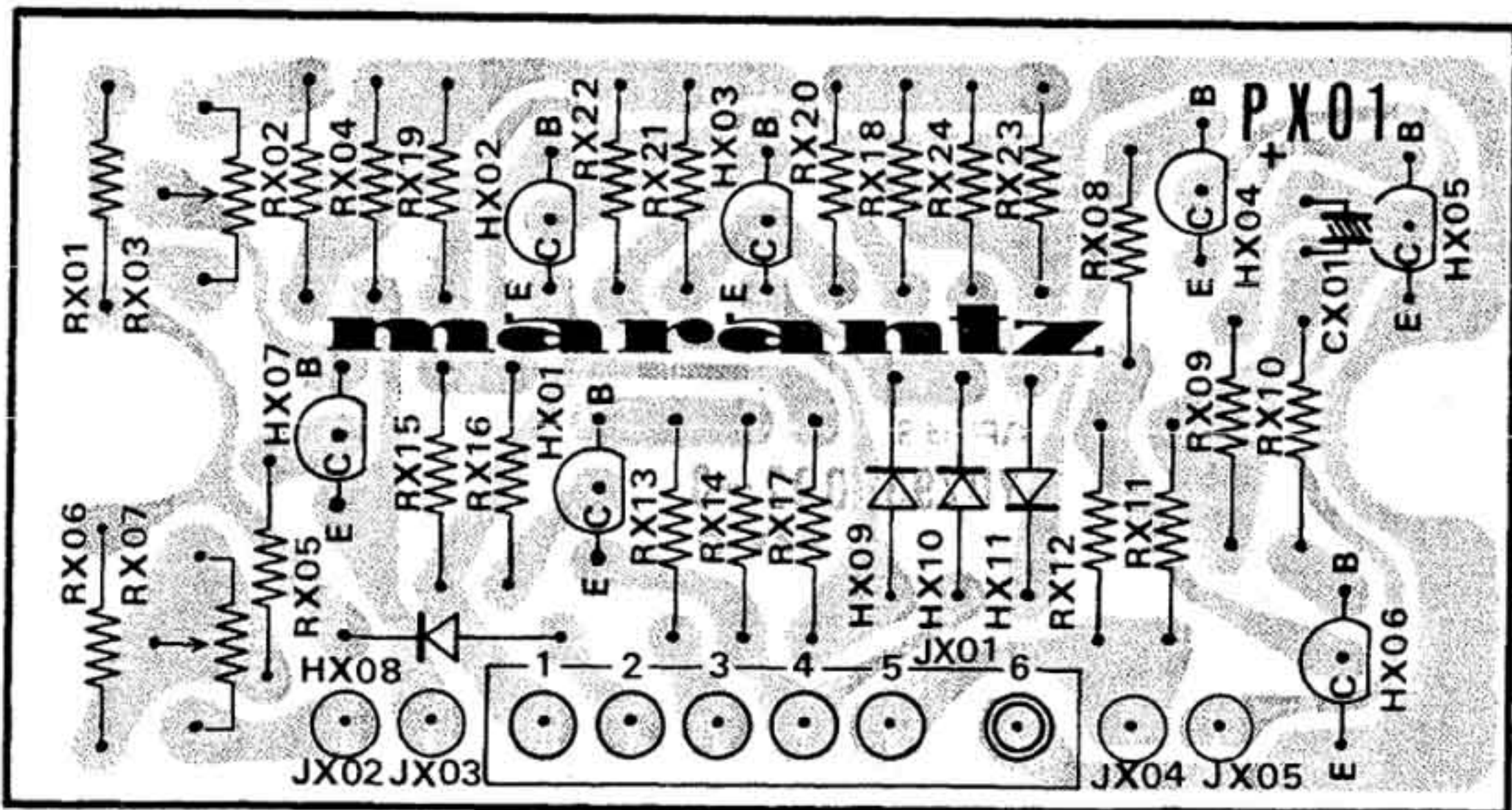
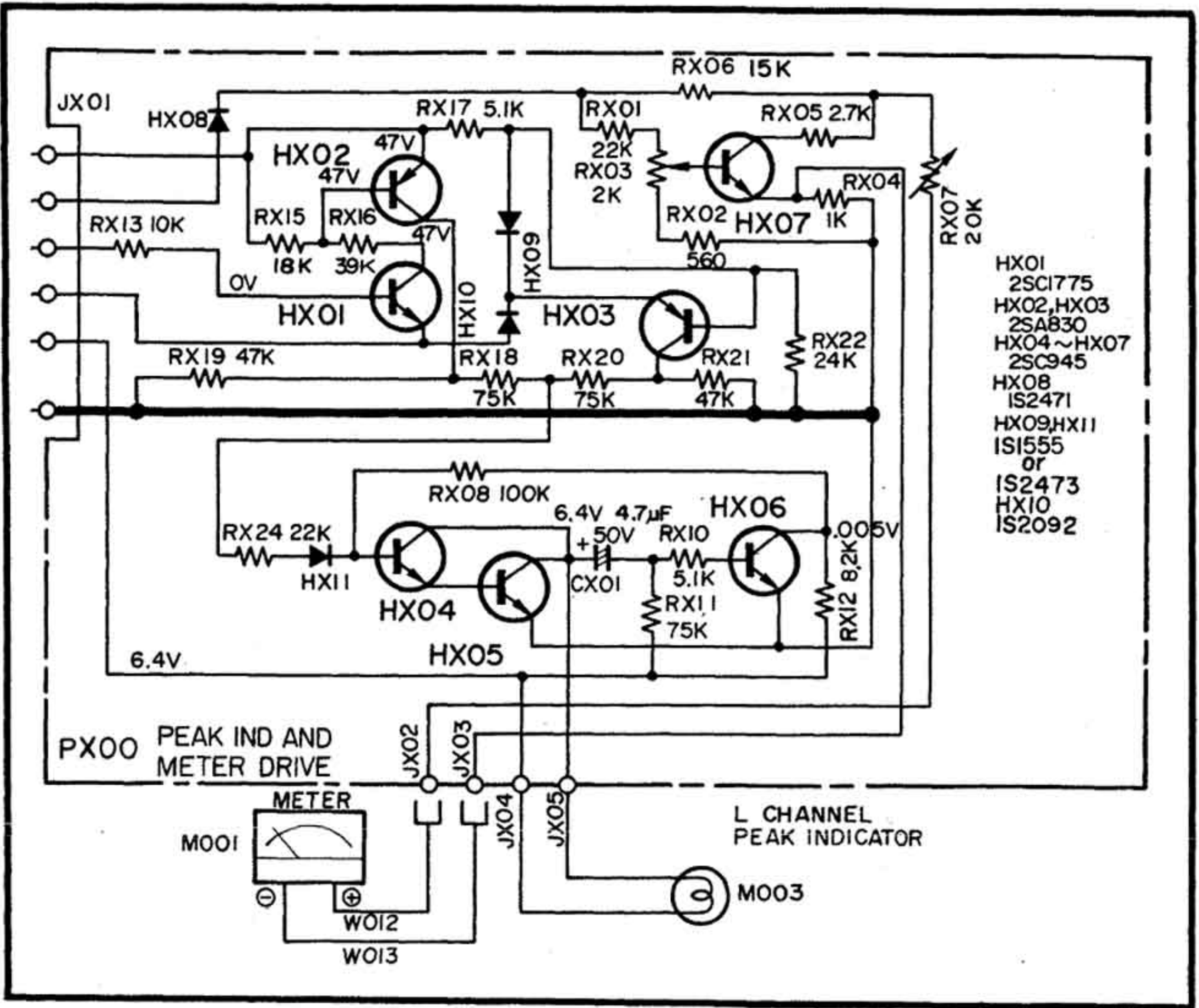

Figure 10. Meter/Peak Ind. Schematic Diagram and Component Locations

TECHNICAL SPECIFICATIONS FOR U.S.A. MODEL

RATED POWER OUTPUT ..... 75 WATTS PER CHANNEL,  
CONTINUOUS AVERAGE POWER,  
BOTH CHANNELS DRIVEN.

POWER BAND ..... 20Hz to 20kHz

TOTAL HARMONIC DISTORTION ..... 0.1%

LOAD IMPEDANCE ..... 80HMS

Input Sensitivity ..... 1.5 V for Rated Power Output

Frequency Response ..... Within  $\pm 0.25$  dB at 1 Watt Output

Intermodulation Distortion ..... Less than 0.15% at Rated Power Output

Damping Factor ..... Greater than 30 into 8 ohm Load

Total Noise from Input to Output ..... -98 dB

GENERAL:

Power Requirements ..... 120 V ~ 50/60 Hz

Idling Power Consumption ..... 30 Watts (Nominal)

Power Consumption at Rated Power Output ..... 250 Watts (Nominal)

Cabinet Dimensions:

Height: ..... 4-3/4 Inches

Width: ..... 14-1/8 Inches

Depth: ..... 10-3/4 Inches

Weight: ..... 24.5 lbs

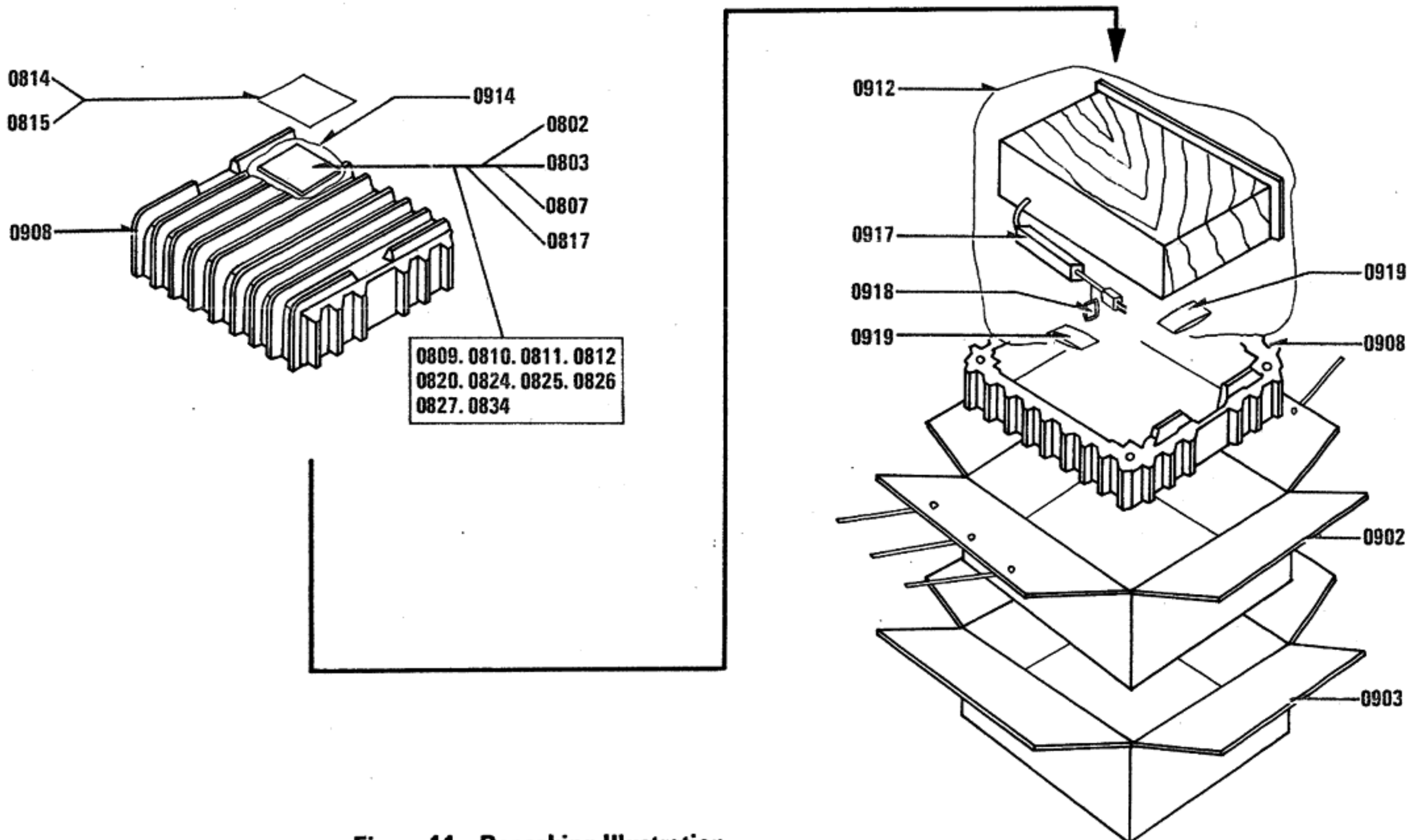



Figure 11. Repacking Illustration

U : For U.S.A.  
 C : For Canada  
 E : For Europe  
 N : For Scandinavia

Parts List

REF. DESIG.	U	C	E	N	PART NO.	DESCRIPTION
A	1	1	1	1	293106340	Front Panel Assembly
0104	1	1	1	1	293106301	Escutcheon
0105	1	1	1	1	293115801	Window
0106	1	1	1	1	291240101	Frame
0107	1	1	1	1	285410701	Sheet
0110	1	1	1	1	293105301	Cover
B	1	1	1	1	293125740	Lid Assembly, Top
0112	1	1	1	1	293125701	Lid
0113	4	4	4	4	257711807	Spacer
3136	2	2	2	2	292705601	Buffer
C			1		293116040	Rear Panel Assembly
0604			1		293116012	Rear Panel
0616			1		282125901	Bush
0617			2		55060305S	T.R. Rivet
0109	4	4	4	4	52017039J	Bolt
0114	4	4	4	4	51480406S	B H M Screw F B4 X 6
0131	2	2	2	2	282815402	Knob
0203	1	1	1	1	293116050	Bracket K
0206	1	1	1	1	293116002	Bracket
0207	1	1	1	1	293116003	Bracket
0208	2	2	2	2	293116016	Bracket
0211	2	2	2	2	293127401	Reflector
0212	2	2	2	2	293116005	Bracket
0213	2	2	2	2	293110702	Sheet
0216	2	2	2	2	291225901	Bush
0221	4	4	4	4	51100306S	B H M Screw B3 X 6
0222	4	4	4	4	51100306S	B H M Screw B3 X 6
0223	6	6	6	6	51100310S	B H M Screw F B3 X 10
0224	2	2	2	2	51380306P	P H Tapped Screw P3 X 6ST
0225	4	4	4	4	51100305A	B H M Screw B3 X 5
0226	4	4	4	4	51100306S	B H M Screw B3 X 6
0227	6	6	6	6	53110303A	Hexagon Nut
0230	4	4	4	4	51100306S	B H M Screw B3 X 6
0231	4	4	4	4	51100406S	B H M Screw B4 X 6
0304	1	1	1	1	293110501	Chassis
0305	2	2	2	2	293100401	Table
0306	12	12	12	12	51100406S	B H M Screw B4 X 6
0308	4	4	4	4	51490510A	B H M Screw FS B5 X 10
0309	1	1	1	1	293116015	Bracket
0310	1	1	1	1	51100306B	B H M Screw B3 X 6
0311	4	4	4	4	293205701	Leg
0312	4	4	4	4	51440410S	B H M Screw S B4 X 10
0313	1	1	1	1	54050300R	T L Washer OR
0315	3	3	3	3	54020401A	Flat Washer P
0316	3	3	3	3	53110401A	Hexagon Nut
0317	3	3	3	3	51100410S	B H M Screw B4 X 10
0318	1	1	1	1	293126703	Heat Sink
0319	1	1	1	1	51100316B	B H M Screw B3 X 16
0320	2	2	2	2	51100306B	B H M Screw B3 X 6
0321	2	2	2	2	62030039W	Lug
0322			1	1	293116017	Bracket
0323			1	1	51100306A	B H M Screw B3 X 6
0324			1	1	51062606A	B H M Screw B2.6 X 6
0327	3	3	3	3	54040402A	Spring Washer
0328			1	1	951022101	Label, Caution
0403	2	2	2	2	293126701	Heat Sink
0404	2	2	2	2	293116009	Bracket
0405	4	4	4	4	51100306S	B H M Screw B3 X 6
0407	2	2	2	2	62030039W	Lug

REF. DESIG.	U	C	E	N	PART NO.	DESCRIPTION
0409	8	8	8	8	281810104	Support
0410	8	8	8	8	51100306S	B H M Screw B3 X 6
0412	2	2	2	2	293126702	Heat Sink
0413	2	2	2	2	51040306S	F H M Screw F3 X 6
0414	2	2	2	2	54040302N	Spring Washer
0415	2	2	2	2	53110303E	Hexagon Nut
0416	2	2	2	2	51100310E	B H M Screw B3 X 10
0417	4	4	4	4	291726702	Heat Sink
0418	4	4	4	4	51100308S	B H M Screw B3 X 8
0419	4	4	4	4	53110303E	Hexagon Nut
0421	4	4	4	4	281826703	Heat Sink
0422	8	8	8	8	51100310E	B H M Screw 93 X 10
0423	8	8	8	8	53110303E	Hexagon Nut
0424	8	8	8	8	54050300R	T L Washer IR
0425	8	8	8	8	53110301E	Hexagon Nut
0426	8	8	8	8	54040302N	Spring Washer
0429	2	2	2	2	53110301E	Hexagon Nut
0430	2	2	2	2	54020301E	Flat Washer P
0503	2	2	2	2	293110101	Support
0505	2	2	2	2	291705501	Collar
0506	2	2	2	2	59110339H	Washer
0507	2	2	2	2	257700501	Clamper
0508	2	2	2	2	51100325E	B H M Screw B3 X 25
0511	4	4	4	4	257711802	Spacer
0514	8	8	8	8	51100312E	B H M Screw B3 X 12
0517	4	4	4	4	51100306S	B H M Screw B3 X 6
0520	4	4	4	4	51100306S	B H M Screw B3 X 6
0523	2	2	2	2	293110901	Shield
0526	1	1	1	1	293126704	Heat Sink
0527	1	1	1	1	51100308B	B H M Screw B3 X 8
0528	1	1	1	1	53110303E	Nut
0529	1	1	1	1	54040302N	Spring Washer
0530	1	1	1	1	54050300R	T L Washer OR
0603	1	1			293116011	Bracket
0608				1	288286102	Label, 
0609				1	62041760W	Lug
0610				1	54050400R	T L Washer OR
0611	4	4	4	4	51100406S	B H M Screw B4 X 6
0613			2	2	51100306S	B H M Screw B3 X 6
0615	1	1			145525903	Bush
0618			2		53110303A	Hexagon Nut
0619			2		51100316A	B H M Screw B3 X 16
0620			2		54050300R	T L Washer OR
0622	1	1	1	1	293116010	Bracket
0623	2	2	2	2	51100306S	B H M Screw B3 X 6
0624	2	2	2	2	51100306S	B H M Screw B3 X 6
0626	4	4	4	4	51100306S	B H M Screw B3 X 6
0627	4	4	4	4	53110303A	Hexagon Nut
0628	2	2	2	2	51100306S	B H M Screw B3 X 6
0629	2	2	2	2	53110303A	Hexagon Nut
0630	2	2	2	2	51100308S	B H M Screw B3 X 8
0631	2	2	2	2	53110303A	Hexagon Nut
0632	2	2	2	2	54050300R	T L Washer OR
0702	1				293126501	Indicator, Name Plate
0703		1			293126502	Indicator, Name Plate
0704			1		293126503	Indicator, Name Plate
0710				1	293126509	Indicator, Name Plate
0711	2	2	2	2	51100305S	B H M Screw B3 X 5
0712	1	1	1	1	257886101	Label, Caution
0713	1	1	1	1	257886102	Label, Do not remove
0714	1	1	1	1	257886103	Label, See marking
0719		1			951091101	Label, LL No.



U : For U.S.A.  
 C : For Canada  
 E : For Europe  
 N : For Scandinavia

REF. DESIG.	U	C	E	N	PART NO.	DESCRIPTION
0720		1			282186102	Label, Fuse caution
0721	1				951091102	Label, Factory No.
0724	1				951110101	Label, UL
0730	1	1	1	1	288686101	Label, On Power transf.
0731		1			951022101	Label, Fuse caution
0802	1				293185101	Instructions, Set
0803		1	1	1	293185121	Instructions, Set
0806				1	293185103	Instructions, Set
0807		1			288685110	Instructions Leaflet
0809	1				293185601	Schematic
0810				1	293185602	Schematic
0811		1			293185603	Schematic
0812				1	293185604	Schematic
0814	1		1		281885108	Instructions Accessories
0815		1			287185104	Instructions Accessories
0817	1	1	1		281885104	Instructions Packing
0820	1	1	1	1	288585107	Instructions Mounting template
0824	1		1	1	257785401	Guarantee Card
0825	1		1	1	257785102	Instructions Important
0826	1				257781301	Envelope
0827			1	1	281881301	Envelope
0902	1	1	1		293180101	Packing Case Inner
0903	1	1	1		293180102	Packing Case Outer
0906				1	293180105	Packing Case Inner
0907				1	293180106	Packing Case Outer
0908	2	2	2		289180301	Cushion
0912	1	1	1		901383033	Polyethylene Bag, Set
0914	1	1	1	1	901302501	Polyethylene Bag, Printed matter
0917	1	1	1		102980401	Sleeve Power cord
0918				1	956000004	Hang Tag
0919	2	2	2	2	273182101	Silicagel
0921				1	288280701	Reinforcing
0922	4				952281501	Serial No. Card
0923		4			952301512	Serial No. Card
0924			4		952301511	Serial No. Card
0925				4	952301513	Serial No. Card
0930				1	288286101	Label On packing case
<b>P700 MAIN AMP. BOARD</b>						
P700	2	2	2	2	YD2917003	P.W. Board Main Amp (94V-1)
	2	2	2	2	ZZ2931103	P.W. Board Assembly
R701	2	2	2	2	RT0547414	Resistor, 470KΩ ±5% ¼W
R702	2	2	2	2	RT0510214	Resistor, 1KΩ ±5% ¼W
R703	2	2	2	2	RT0510414	Resistor, 100KΩ ±5% ¼W
R704	2	2	2	2	RT0515114	Resistor, 150Ω ±5% ¼W
R705	2	2	2	2	RT0515314	Resistor, 15KΩ ±5% ¼W
R706	2	2	2	2	RT0539214	Resistor, 3.9KΩ ±5% ¼W
R707	2	2	2	2	GU0510312	Resistor, 10KΩ ±5% ½W
R708	2	2	2	2	RT0510314	Resistor, 10KΩ ±5% ¼W
R709	2	2	2	2	RT0510214	Resistor, 1KΩ ±5% ¼W
R710	2	2	2	2	RT0522414	Resistor, 220KΩ ±5% ¼W
R711	2	2	2	2	RT0562214	Resistor, 6.2KΩ ±5% ¼W
R712	2	2	2	2	RT0513314	Resistor, 13KΩ ±5% ¼W
R713	2	2	2	2	RT0512214	Resistor, 1.2KΩ ±5% ¼W
R714	2	2	2	2	RT0510114	Resistor, 100Ω ±5% ¼W
R715	2	2	2	2	RT0556014	Resistor, 56Ω ±5% ¼W
R716	2	2	2	2	GJ0515201	Resistor, 1.5KΩ ±5% 1W
R717	2	2	2	2	GJ0515201	Resistor, 1.5KΩ ±5% 1W
R718	2	2	2	2	RT0568114	Resistor, 680Ω ±5% ¼W

REF. DESIG.	U	C	E	N	PART NO.	DESCRIPTION
R719	2	2	2	2	RT0568114	Resistor, 680Ω ±5% ¼W
R720	2	2	2	2	RT0530114	Resistor, 300Ω ±5% ¼W
R721	2	2	2	2	RT0527314	Resistor, 27KΩ ±5% ¼W
R722	2	2	2	2	RT0527314	Resistor, 27KΩ ±5% ¼W
R723	2	2	2	2	RT0510414	Resistor, 100KΩ ±5% ¼W
R724	2	2	2	2	RT0547314	Resistor, 47KΩ ±5% ¼W
R725	2	2	2	2	RT0510114	Resistor, 100Ω ±5% ¼W
R726	2	2	2	2	RT0510114	Resistor, 100Ω ±5% ¼W
R727	2	2	2	2	RT0502214	Resistor, 2.2Ω ±5% ¼W
R728	2	2	2	2	RC0000012	Resistor, 0Ω
R729	2	2	2	2	RT0510214	Resistor, 1KΩ ±5% ¼W
R730	2	2	2	2	RT0533214	Resistor, 3.3KΩ ±5% ¼W
R731	2	2	2	2	RT0533214	Resistor, 3.3KΩ ±5% ¼W
R732	2	2	2	2	RT0518114	Resistor, 180Ω ±5% ¼W
R733	2	2	2	2	RT0515114	Resistor, 150Ω ±5% ¼W
R734	2	2	2	2	GF0510112	Resistor, 100Ω ±5% ½W
R735	2	2	2	2	GF0510112	Resistor, 100Ω ±5% ½W
R736	2	2	2	2	RT0510114	Resistor, 100Ω ±5% ¼W
R737	2	2	2	2	RT0510114	Resistor, 100Ω ±5% ¼W
R738	2	2	2	2	GJ0502202	Resistor, 2.2Ω ±5% 2W
R739	2	2	2	2	GJ0510002	Resistor, 10Ω ±5% 2W
R740	2	2	2	2	BX1020201	Resistor, 0.2+0.2Ω ±10%5W
R741	2	2	2	2	RA0202013	Trimming Resistor, 2KΩ(B)
R742	2	2	2	2	RA0202013	Trimming Resistor, 2KΩ(B)
R743	2	2	2	2	RC0000012	Resistor, 0Ω
R745	2	2	2	2	RT0556114	Resistor, 560Ω ±5% ¼W
R746	2	2	2	2	RC0000012	Resistor, 0Ω
R747	2	2	2	2	RT0582014	Resistor, 82Ω ±5% ¼W
R748	2	2	2	2	RC0000012	Resistor, 0Ω
L701	2	2	2	2	LC2202001	Choke Coil 2μH
C701	2	2	2	2	DF1710552	Film Cap, 1μF ±20% 250V
C702	2	2	2	2	EE4760162	Electrolytic Cap, 47μF ±20% 16V
C703	2	2	2	2	EA1060169	Electrolytic Cap, 10μF ±5% 16V
C704	2	2	2	2	EA1060169	Electrolytic Cap, 10μF ±5% 16V
C705	2	2	2	2	DD1510101	Ceramic Cap, 100PF ±5% 50V
C706	2	2	2	2	DK1610201	Ceramic Cap, 1000PF ±10% 50V
C707	2	2	2	2	DK1622151	Ceramic Cap, 220PF ±10% 500V
C708	2	2	2	2	DD1105050	Ceramic Cap, 5PF ±0.25P 500V
C709	2	2	2	2	DD1515150	Ceramic Cap, 150PF ±5% 500V
C710	2	2	2	2	DF1710452	Film Cap, 0.1μF ±20% 200V
C711	2	2	2	2	DF1710452	Film Cap, 0.1μF ±20% 200V
C712	2	2	2	2	DF1710452	Film Cap, 0.1μF ±20% 200V
C713	2	2	2	2	DD1647050	Ceramic Cap, 47PF ±10% 500V
C714	2	2	2	2	DD1647050	Ceramic Cap, 47PF ±10% 500V
C715	2	2	2	2	DF1722305	Ceramic Cap, 0.022μF ±20% 50V
C716	2	2	2	2	DF1722305	Ceramic Cap, 0.022μF ±20% 50V
C719	2	2	2	2	DF1710405	Film Cap, 0.1μF ±20% 50V
C720	2	2	2	2	DF1710351	Film Cap, 0.01μF ±20% 200V
C721	2	2	2	2	DK1650150	Ceramic Cap, 500PF ±10% 500V
H701	1	1	1	1	HT313271T	Transistor, 2SC1327 T.U
H702	1	1	1	1	HT313271T	Transistor, 2SC1327 T.U
H703	2	2	2	2	HT107212A	Transistor, 2SA721 S.T
H704	2	2	2	2	HT313272A	Transistor, 2SC1327 S.T
H705	2	2	2	2	HT309452A	Transistor, 2SC945 Q.R
H706	2	2	2	2	HT107332A	Transistor, 2SA733 P.Q
H707	2	2	2	2	HT309452A	Transistor, 2SC945 Q.R
H708	2	2	2	2	HT107332A	Transistor, 2SA733 P.Q
H709	2	2	2	2	HT304961B	Transistor, 2SC496 O
H710	2	2	2	2	HV0000705	Varistor, S3016R
H711	1	1	1	1	HT107941Q	Transistor, 2SA794 Q.R
H712	1	1	1	1	HT315671Q	Transistor, 2SC1567 Q.R
H713	1	1	1	1	HT316251A	Transistor, 2SC1625 O.Y

U : For U.S.A.  
 C : For Canada  
 E : For Europe  
 N : For Scandinavia

REF. DESIG.	U	C	E	N	PART NO.	DESCRIPTION
H714	1	1	1	1	HT108151A	Transistor, 2SA815 O.Y
H715	2	2	2	2	HD3002509	Diode, WZ 150 (15V±5%)
H716	2	2	2	2	HD3002509	Diode, WZ 150 (15V±5%)
H717	2	2	2	2	HD2000321	Diode, IS2471 (Black)
H718	2	2	2	2	HD2000321	Diode, IS2471 (Black)
H720	2	2	2	2	HD2001105	Diode, IS1555
H721	2	2	2	2	HD2001105	Diode, IS1555
H719	2	2	2	2	HH0000703	Thermistor, SDT100(1KΩ@25°C)
H722	2	2	2	2	HH0000703	Thermistor, SDT100(1KΩ@25°C)
H723	2	2	2	2	HH0000703	Thermistor, SDT100(1KΩ@25°C)
J701	2	2	2	2	YP1000109	Plug
J702	2	2	2	2	YP1000109	Plug
J703	2	2	2	2	YP1000113	Plug
J704	2	2	2	2	YP1000113	Plug
J705	2	2	2	2	YP1000113	Plug
J706	2	2	2	2	YP1000113	Plug
J707	2	2	2	2	YP1000113	Plug
J708	2	2	2	2	YP1000113	Plug
J709	2	2	2	2	YPO600031	Plug
J710	2	2	2	2	YPO600030	Plug
J711	2	2	2	2	YP1000109	Plug
J712	2	2	2	2	YP1000109	Plug
PN00	1	1	1	1	YD2931001 ZZ2931001	<b>PN00 RELAY BOARD</b> P.W.Board Relay PWB (94V-0) P.W. Board Assembly
RN01	1	1	1	1	GU0556212	Resistor, 5.6KΩ ±5% ½W
RN02	1	1	1	1	GU0556212	Resistor, 5.6KΩ ±5% ½W
RN03	1	1	1	1	RT0568214	Resistor, 6.8KΩ ±5% ¼W
RN04	1	1	1	1	RT0527314	Resistor, 27KΩ ±5% ¼W
RN05	1	1	1	1	RT0533314	Resistor, 33KΩ ±5% ¼W
RN06	1	1	1	1	RT0539314	Resistor, 39KΩ ±5% ¼W
RN07	1	1	1	1	RT0522414	Resistor, 220KΩ ±5% ¼W
RN08	1	1	1	1	GJ0547101	Resistor, 470Ω ±5% 1W
RN09	1	1	1	1	GJ0512103	Resistor, 120Ω ±5% 3W
RN10	1	1	1	1	GF0547212	Resistor, 4.7KΩ ±5% ½W
CN01	1	1	1	1	DF1710452	Film Cap, 0.1μF 200V
CN02	1	1	1	1	EA1060509	Electrolytic Cap, 10μF 50V
CN03	1	1	1	1	EA4760169	Electrolytic Cap, 47μF 16V
CN04	1	1	1	1	EA2270109	Electrolytic Cap, 220μF 10V
CN05	1	1	1	1	EA3360509	Electrolytic Cap, 33μF 50V
CN06	1	1	1	1	EA4760109	Electrolytic Cap, 47μF 10V
LN01	1	1	1	1	LY2024006	Relay MY2 24V
HN01	1	1	1	1	HT309452A	Transistor, 2SC945 Q.R
HN02	1	1	1	1	HT313183A	Transistor, 2SC1318 P.Q.R
HN03	1	1	1	1	HT313183A	Transistor, 2SC1318 P.Q.R
HN04	1	1	1	1	HD2001103	Diode, DS131B
HN05	1	1	1	1	HD2000110	Diode, 10D-2
HN06	1	1	1	1	HT403314A	Transistor, 2SD331
HN07	1	1	1	1	HD3002309	Diode, WZ-071
HN08	1	1	1	1	HD2000110	Diode, 10D-2
JN01	1	1	1	1	YP1000113	Plug
JN02	1	1	1	1	YP1000113	Plug
JN03	1	1	1	1	YP1000113	Plug
JN04	1	1	1	1	YP1000113	Plug
JN05	1	1	1	1	YP1000113	Plug
JN06	1	1	1	1	YP1000113	Plug
JN07	1	1	1	1	YP1000113	Plug
JN08	1	1	1	1	YP1000113	Plug

REF. DESIG.	U	C	E	N	PART NO.	DESCRIPTION
PX00	2	2	2	2	YD2931002 ZZ2931002	<b>PX00 PEAK IND. &amp; METER BOARD</b> P.W.B.Peak Ind.& Meter (94V-0) P.W. Board Assembly
CX01	2	2	2	2	EA4750509	Electrolytic Cap, 4.7μF 50V
RX01	2	2	2	2	RT0522314	Resistor, 22KΩ ±5% ¼W
RX02	2	2	2	2	RT0556114	Resistor, 560Ω ±5% ¼W
RX03	2	2	2	2	RA0202013	Trimming Resist, 2KΩ(B)
RX04	2	2	2	2	RT0510214	Resistor, 1KΩ ±5% ¼W
RX05	2	2	2	2	RT0527214	Resistor, 2.7KΩ ±5% ¼W
RX06	2	2	2	2	RT0515314	Resistor, 15KΩ ±5% ¼W
RX07	2	2	2	2	RA0203010	Trimming Resist, 20KΩ(B)
RX08	2	2	2	2	RT0510414	Resistor, 100KΩ ±5% ¼W
RX10	2	2	2	2	RT0551214	Resistor, 5.1KΩ ±5% ¼W
RX11	2	2	2	2	RT0575314	Resistor, 75KΩ ±5% ¼W
RX12	2	2	2	2	RT0582214	Resistor, 8.2KΩ ±5% ¼W
RX13	2	2	2	2	RT0510314	Resistor, 10KΩ ±5% ¼W
RX15	2	2	2	2	RT0518314	Resistor, 18KΩ ±5% ¼W
RX16	2	2	2	2	RT0539314	Resistor, 39KΩ ±5% ¼W
RX17	2	2	2	2	RT0551214	Resistor, 5.1KΩ ±5% ¼W
RX18	2	2	2	2	RT0575314	Resistor, 75KΩ ±5% ¼W
RX19	2	2	2	2	RT0547314	Resistor, 47KΩ ±5% ¼W
RX20	2	2	2	2	RT0575314	Resistor, 75KΩ ±5% ¼W
HX01	2	2	2	2	HT317752E	Transistor, 2SC1775A(E),(F)
HX02	2	2	2	2	HT108722D	Transistor, 2SA872A(D),(E)
HX03	2	2	2	2	HT108722D	Transistor, 2SA872A(D),(E)
HX04	2	2	2	2	HT309452A	Transistor, 2SC945 Q or R
HX05	2	2	2	2	HT309452A	Transistor, 2SC945 Q or R
HX06	2	2	2	2	HT309452A	Transistor, 2SC945 Q or R
HX07	2	2	2	2	HT309452A	Transistor, 2SC945 Q or R
HX08	2	2	2	2	HD2000321	Diode, IS2471 (Black)
HX09	2	2	2	2	HD2000121	Diode, IS2473 (Yellow)
HX10	2	2	2	2	HD2001805	Diode, IS2471 (Black)
HX11	2	2	2	2	HD2000121	Diode, IS2473 (Yellow)
JX01	2	2	2	2	YPO600048	Plug
JX02	2	2	2	2	YP1000109	Plug
JX03	2	2	2	2	YP1000109	Plug
JX04	2	2	2	2	YP1000113	Plug
JX05	2	2	2	2	YP1000113	Plug
RX21	2	2	2	2	RT0547314	Resistor, 47KΩ ±5% ¼W
RX22	2	2	2	2	RT0524314	Resistor, 24KΩ ±5% ¼W
RX24	2	2	2	2	RT0522314	Resistor, 22KΩ ±5% ¼W
L001	1	1			TS6050401 TS6050402	Power Transformer Power Transformer
R001	1	1	1	1	RK0503011	Variable Resist, 50KΩ(B)
R002	1	1	1	1	RK0503011	Variable Resist, 50KΩ(B)
R003	1	1	1	1	GJ0522202	Resistor, 2.2KΩ ±5% 2W
R004	1	1	1	1	GJ0522202	Resistor, 2.2KΩ ±5% 2W
C001	1	1	1	1	ES1390551	Electrolytic Cap 13mFX2 55WV
F001	1	1			FS1050004 FS1050006	Fuse, 5A MGC Fuse, 5A
F002		1			FS2050001	Fuse, 5A
F003			1		FS1040006	Fuse, 4A (20mm)
F004			1		FS1040006	Fuse, 4A (20mm)
M001	1	1	1	1	IM1108201	DC Meter, Level Meter
M002	1	1	1	1	IM1108201	DC Meter, Level Meter

U : For U.S.A.  
 C : For Canada  
 E : For Europe  
 N : For Scandinavia

REF. DESIG.	U	C	E	N	PART NO.	DESCRIPTION
M003	1	1	1	1	IN1008029	Lamp, Peak Ind. 8V 60mA
M004	1	1	1	1	IN1008029	Lamp, Peak Ind. 8V 60mA
M005	1	1	1	1	IN1008007	Lamp, Meter Lamp
M006	1	1	1	1	IN1008007	Lamp, Meter Lamp
M007	1	1	1	1	IN1008007	Lamp, Meter Lamp
M008	1	1	1	1	IN1008007	Lamp, Meter Lamp
J001	1	1	1	1	YT0201009	Terminal, 1P Input
J002	1	1	1	1	YT0201009	Terminal, 1P Input
J003	1	1	1	1	YJ0600084	Jack, 3P
J004	1	1	1	1	YJ0600084	Jack, 3P
J005	1	1	1	1	YJ0500019	Socket, Power Transistor
J006	1	1	1	1	YJ0500019	Socket, Power Transistor
J007	1	1	1	1	YJ0500019	Socket, Power Transistor
J008	1	1	1	1	YJ0500019	Socket, Power Transistor
J009	1	1	1	1	YJ0600070	Jack, 5P
J010	1	1	1	1	YJ0600071	Jack, 5P
J011	1	1	1	1	YJ0600072	Jack, 6P
J012	1	1	1	1	YJ0600073	Jack, 6P
J013	1	1	1	1	YT0304012	Terminal, Speaker
J014	1	1	1	1	YJ0800019	Socket, Meter Lamp
J015	1	1	1	1	YJ0800019	Socket, Meter Lamp
J016	1	1	1	1	YJ0800019	Socket, Meter Lamp
J017	1	1	1	1	YJ0800019	Socket, Meter Lamp
J018	1	1			YJ0800012	Jack, Fuse Holder
J019	1	1	1	1	YJ0400048	Jack, AC Outlet
J020			1	1	BY0314001	Terminal, Line Selector
J021			1		YJ0800009	Socket, Fuse Holder
J022			1		YJ0800022	Jack, Fuse Holder
H001	1	1	1	1	4611035000	Transistor, S-40442 SJ2518
H002	1	1	1	1	4621041000	Transistor, S-40443 SJ2517
H003	1	1	1	1	4611035000	Transistor, S-40442 SJ2518
H004	1	1	1	1	4621041000	Transistor, S-40443 SJ2517
H005	1	1	1	1	HD2001705	Diode, S5188
W012	1	1	1	1	YB0020014	Connective Cord
W013	1	1	1	1	YB0020015	Connective Cord
W014	1	1	1	1	YB0020014	Connective Cord
W015	1	1	1	1	YB0020015	Connective Cord
	1	1	1	1	293185501	Service Manual

--	--	--	--	--	--	--

## SERVICE INFORMATION FOR EUROPEAN MODEL

The information contained herein included rear panel and main chassis component locations, voltage conversion, schematic diagram and technical specifications. For the alignment procedures, test equipment, and repairing hints, refer to the original service manual.

### TABLE OF CONTENTS

Technical Specifications .....	19
Rear Panel Jacks and Component Locations .....	20
Main Chassis Component Locations (Bottom View) .....	20
Schematic Diagram .....	21
Voltage Conversion .....	23
Voltage Conversion Chart .....	23

### TECHNICAL SPECIFICATIONS FOR EUROPEAN MODEL

RATED POWER OUTPUT ..... 75 WATTS PER CHANNEL,  
CONTINUOUS AVERAGE POWER,  
BOTH CHANNELS DRIVEN.

POWER BAND ..... 20Hz to 20kHz

TOTAL HARMONIC DISTORTION ..... 0.1%

LOAD IMPEDANCE ..... 8 OHMS

Input Sensitivity ..... 1.5 V for Rated Power Output

Frequency Response ..... Within  $\pm 0.25$  dB at 1 Watt Output

Intermodulation Distortion ..... Less than 0.15% at Rated Power Output

Damping Factor ..... Greater than 30 into 8 ohm Load

Total Noise from Input to Output ..... -98 dB

### GENERAL:

Power Requirements ..... 220 V AC 50/60Hz

Idling Power Consumption ..... 30 Watts (Nominal)

Power Consumption at Rated Power Output ..... 250 Watts (Nominal)

#### Cabinet Dimensions:

Height: ..... 11.9 cm

Width: ..... 35.3 cm

Depth: ..... 26.9 cm

Weight: ..... 11 Kg

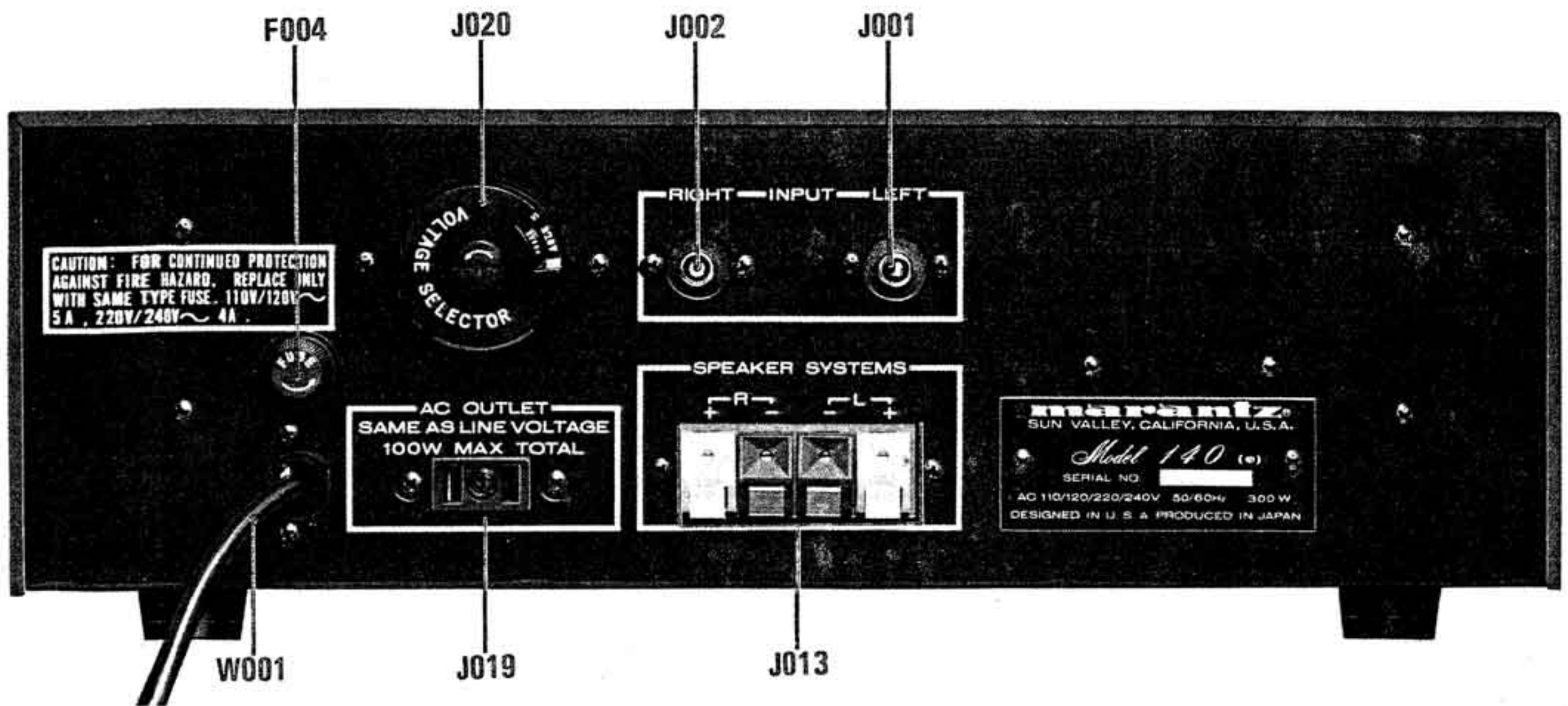

Figure 12. Rear Panel Adjustment and Component Locations for European Model

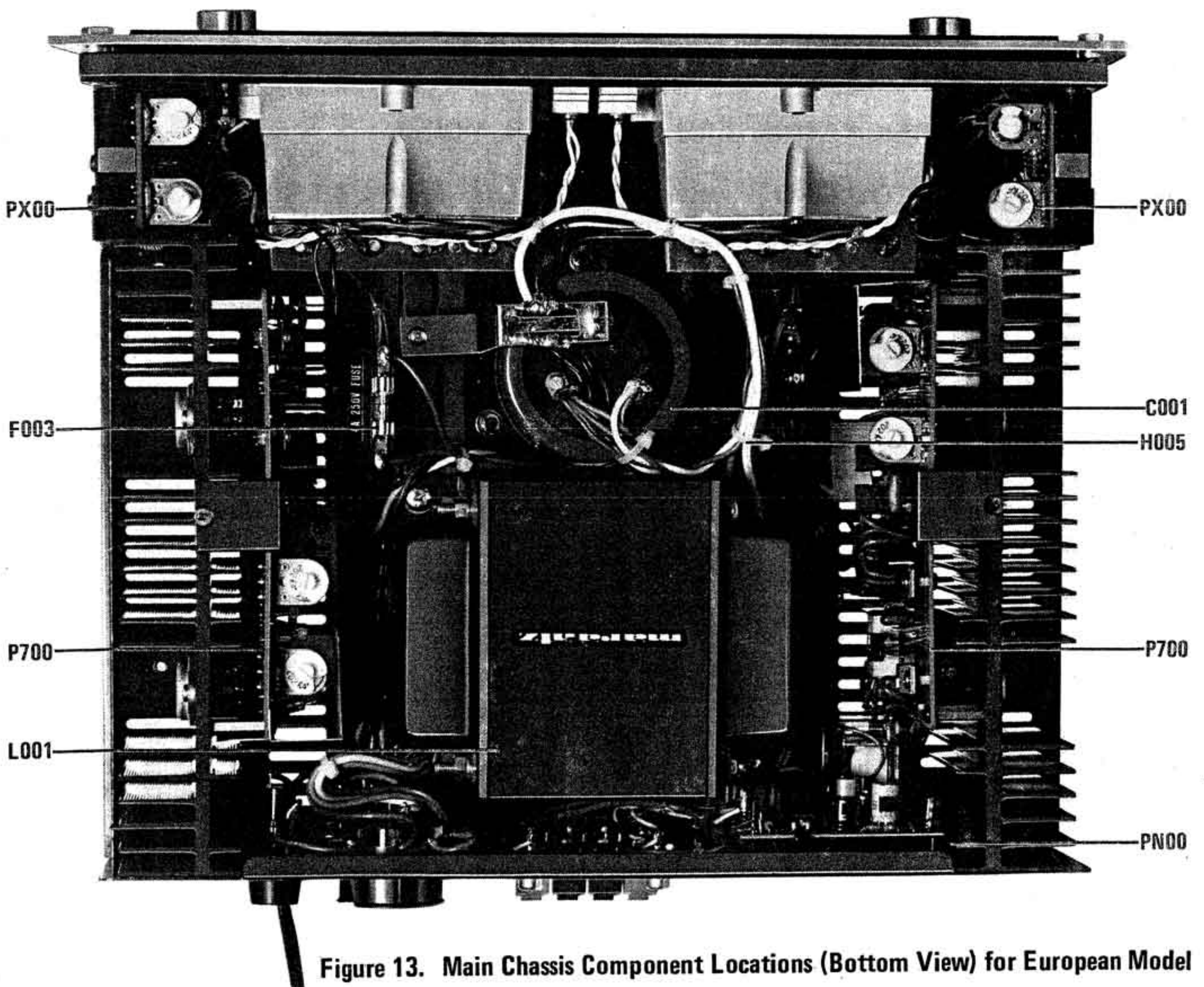
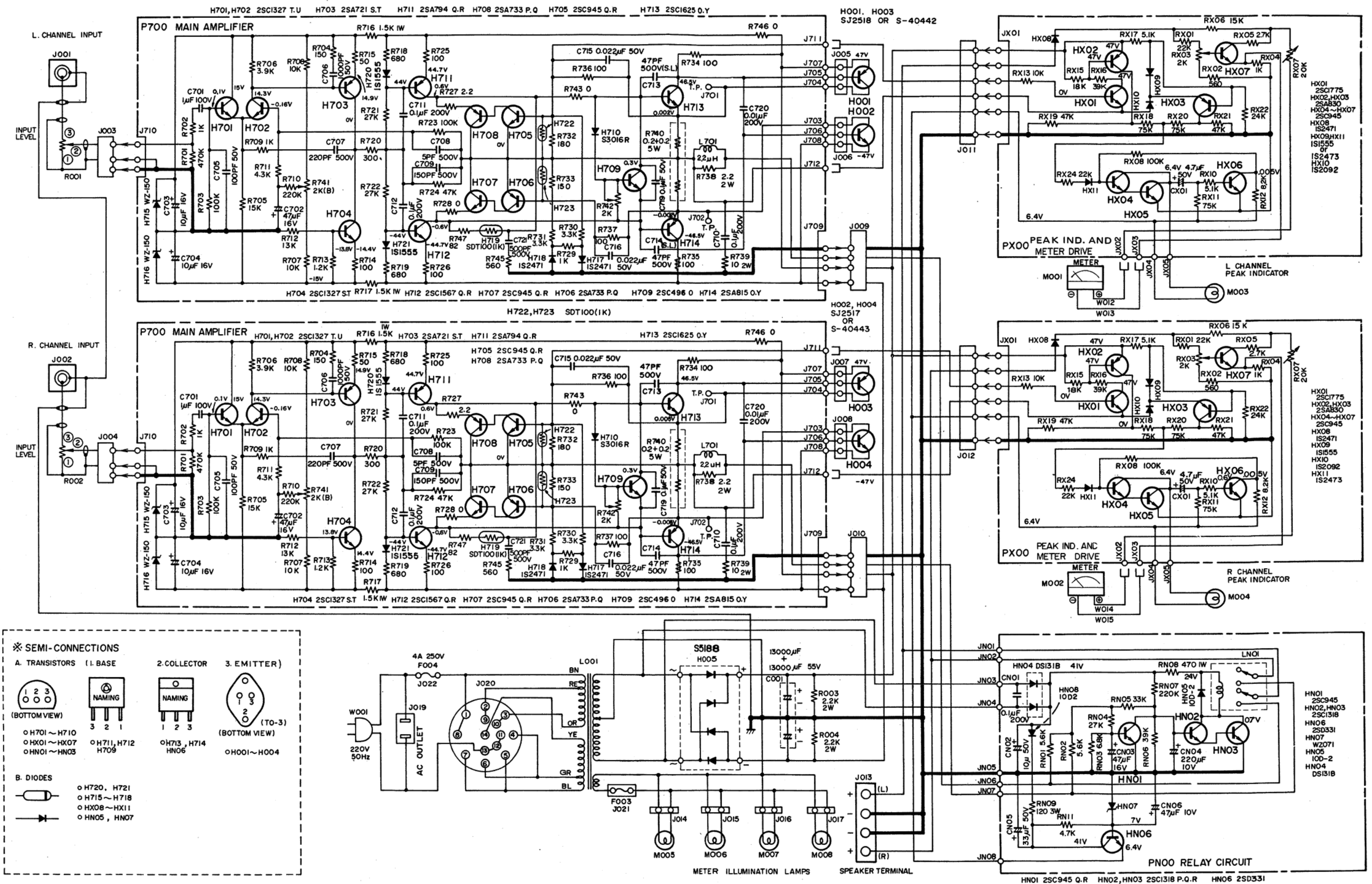

Figure 13. Main Chassis Component Locations (Bottom View) for European Model



## VOLTAGE CONVERSION

This Model is equipped with a universal power transformer to permit operation at 110, 120, 220 and 240 V AC 50/60 Hz.

To convert the unit to the required voltage, set the plug as illustrated so that you can adjust the voltage as required.

**CAUTION: DISCONNECT POWER SUPPLY CORD FROM AC OUTLET BEFORE CONVERTING VOLTAGE.**

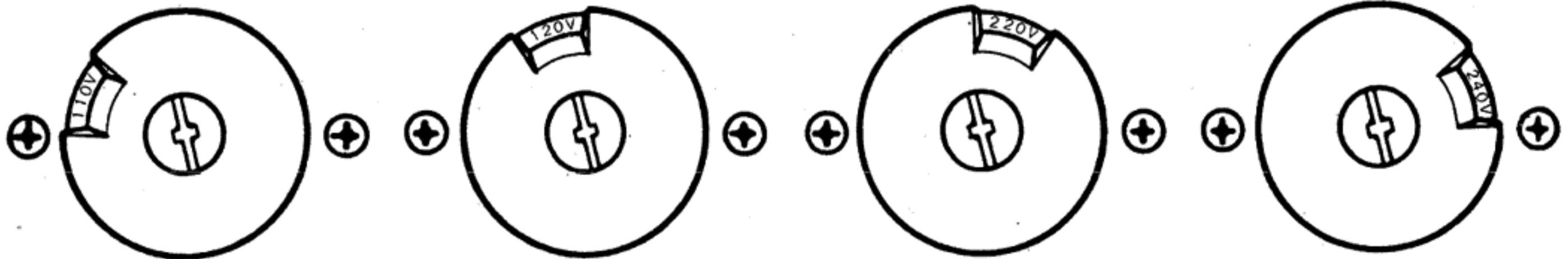
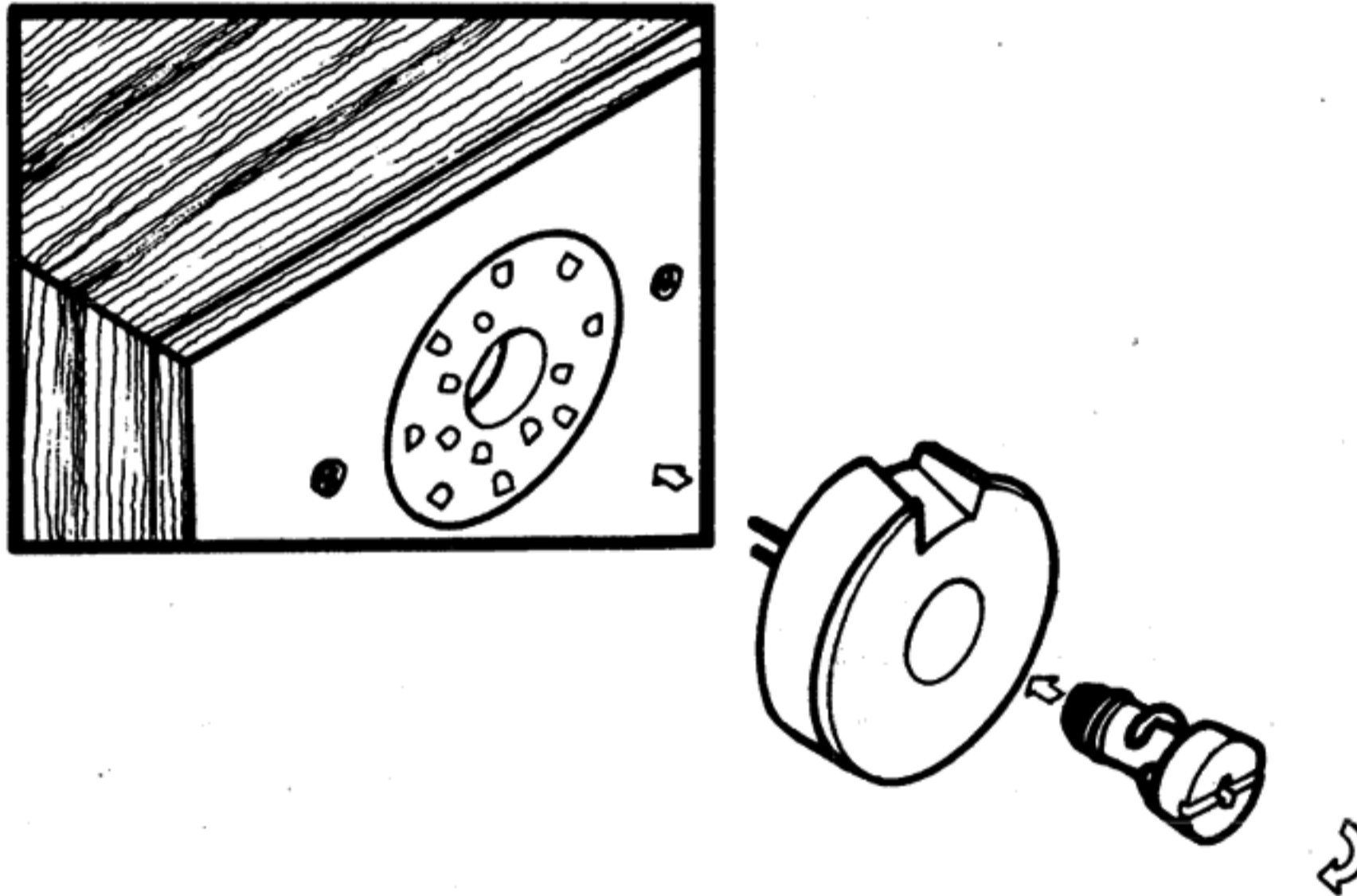

For 110V Operation

For 120V Operation

For 220V Operation

For 240V Operation

Figure 15. Voltage Conversion Chart