

Figure 10. AC Power Control Box Simplified Schematic

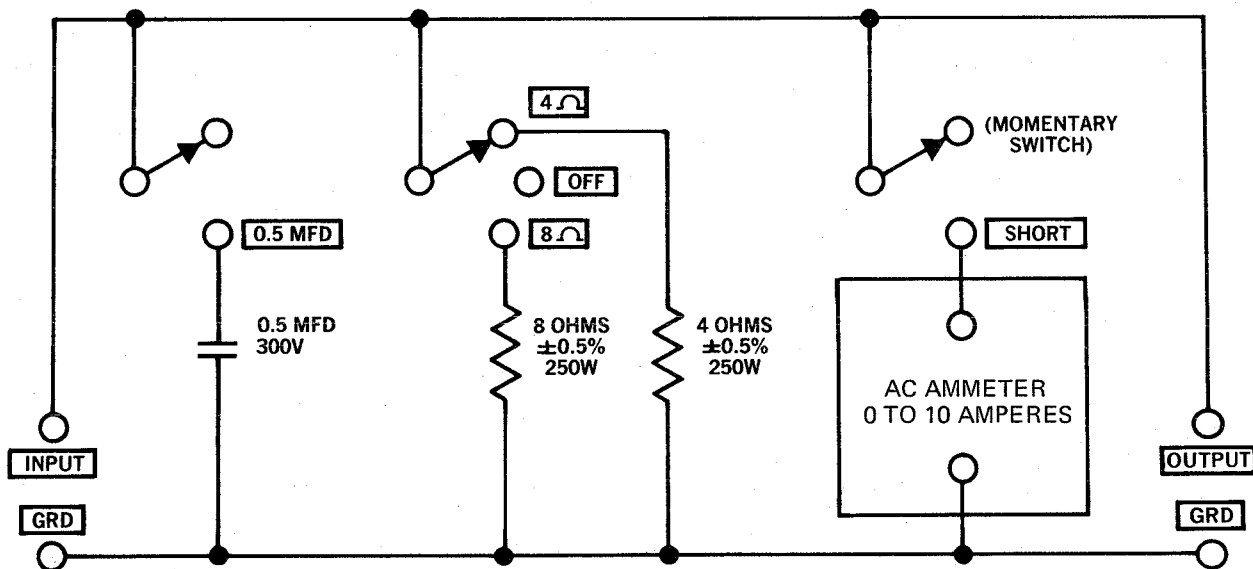
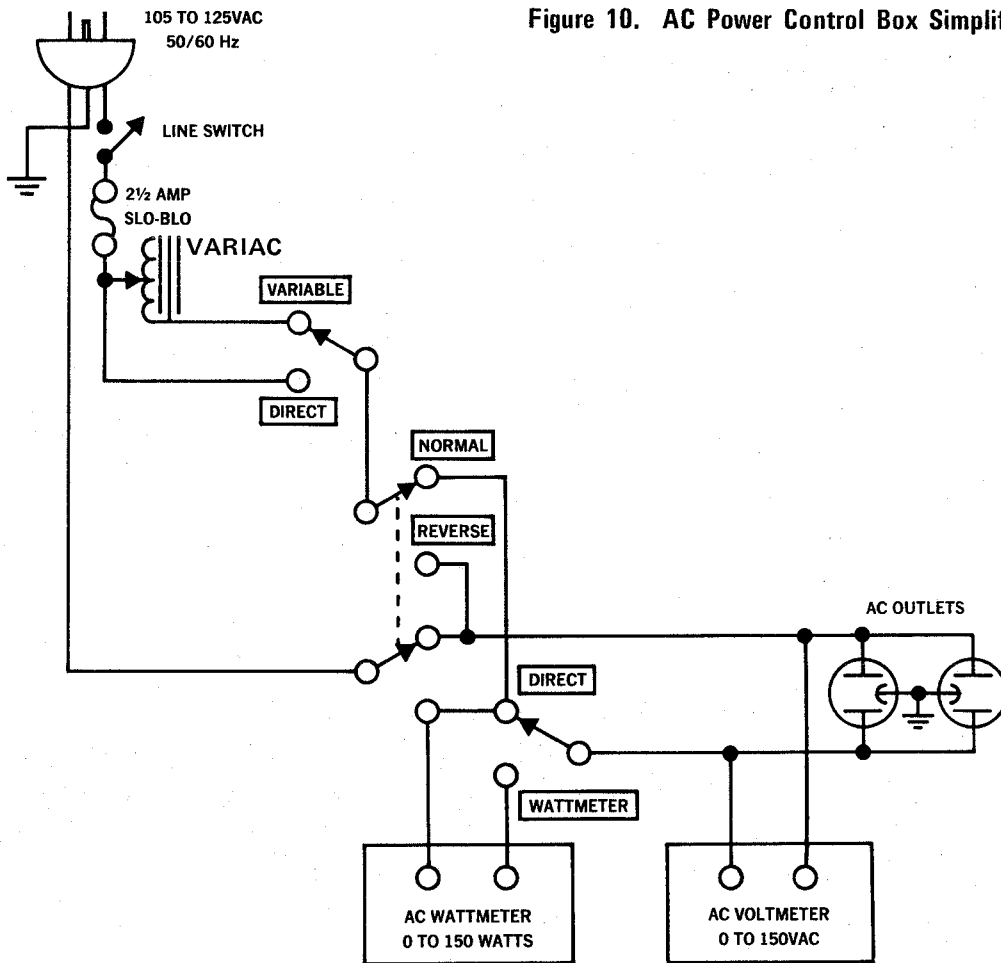

Figure 11. Amplifier Output Load Box Simplified Schematic

TROUBLE ANALYSIS

The following section is designed to assist in locating troubles. The information given is to help in situations where problems may be difficult to isolate. Any field problems that arise will be covered through service bulletins (supplementary to this manual) that will be issued to all service stations. It is assumed that normal trouble-shooting techniques (i.e. point-to-point signal tracing, oscilloscope analysis, etc.) will be used to isolate problems.

NOTE: Performance verification is necessary following any repair.

SYMPTOM	PROCEDURE
1. Excessive line consumption (100 watts or more).	<ul style="list-style-type: none"> a. Check for shorted rectifiers CR601 through CR604, CR701 through CR704, CR705 and CR706. b. Check for shorted transistors Q802 through Q805, Q507, Q508, Q510, Q511. Check for open control R526, 215-1005-1 bias assy. Check T1 for short.
<p>CAUTION: Because the driver and output stages are direct coupled, components may fail as a direct result of an initial component failure. If a shorted semiconductor is found, be sure to check the remaining driver and output components for short or open circuits before re-energizing the amplifier. After replacement of any of these components, increase the Variac voltage slowly while monitoring the wattmeter as described in paragraph C of Performance Verification.</p>	
2. No line consumption or zero bias.	<ul style="list-style-type: none"> a. Check line cord, fuse, transistors Q507, Q508, Q510, Q511, Q802 through Q805, shorted 215-1005-1 bias assy. b. Check for open rectifiers CR601 through CR604, CR701 through 704, CR705 and CR706, or open T1.
3. High d-c voltage at loudspeaker terminals before time delay circuit is activated.	<ul style="list-style-type: none"> a. Check transistors Q701 through Q703 for leakage, shorted, or open.
4. High d-c voltage at loudspeaker at all times.	<ul style="list-style-type: none"> a. Check R701 through 705 for open and Q701 for leakage, or open. Check for shorted or open transistors Q802 through Q805, Q507, Q508, Q510, or Q511.
5. No D-C Balance.	<ul style="list-style-type: none"> a. Check Q501, Q502, R502, and Zener diodes CR501, CR502 (amplifier). Check Q205, Q206, Q201, Q202, R235, and R214 (pre-amplifier). b. Check R501, R503 (amplifier).

- 6. High hum and noise level.
 - 7. Parasitic Oscillation.
 - 8. Improper clipping.
 - 9. Relay Latching.
- a. Check filter capacitors C4, C5, C503 and C504.
 - a. Check for defective C506, C509, C516, and C505.
 - a. Check for proper adjustment of R541, R542.
 - b. Check transistors Q802 through Q805.
 - a. Check Q701 through 703.
 - b. Check output for proper clipping (positive and negative levels must not vary more than 1 volt at 2KHz).
 - c. Check for high level DC offset at junction of R701 and R702.

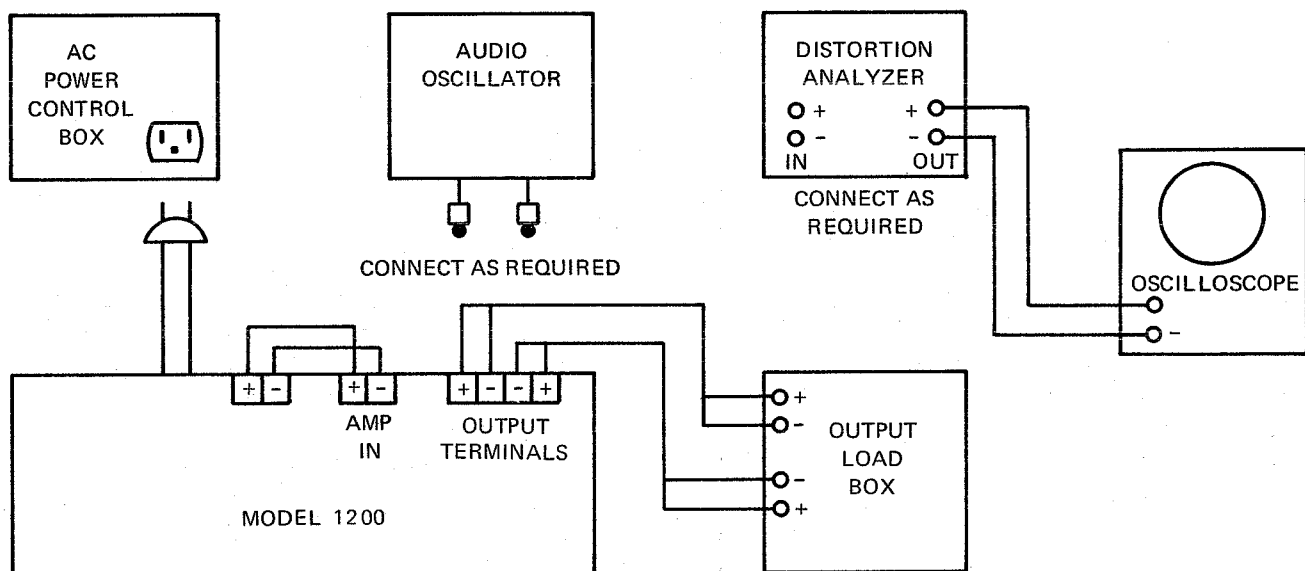

Figure 12. Test Equipment Set-Up

PARTS LIST

Reference Designation	Description and/or Remarks	Marantz Part Number
INTERCONNECT BOARD COMPONENT ASSEMBLY		
C101	Cap., 150pf, $\pm 10\%$, 100V	385-1038
C102	Cap., .03uf, $\pm 20\%$, 100V	383-1002
C103	Cap., 150pf, $\pm 10\%$, 100V	385-1038
C104	Cap., .03uf, $\pm 20\%$, 100V	383-1002
R101	Res., C/F, 8.2K, $\pm 5\%$, $\frac{1}{2}W$	433-4822
R102	Res., C/F, 8.2K, $\pm 5\%$, $\frac{1}{2}W$	433-4822
R103	Res., Variable, Tandem, 100K	420-1017
R104	Res., Variable, Tandem, 250K	420-1016
R105	Res., C/F, 62K, $\pm 5\%$, $\frac{1}{2}W$	433-5622
R106	Res., C/F, 10K, $\pm 5\%$, $\frac{1}{2}W$	433-5102
R107	Res., C/F, 62K, $\pm 5\%$, $\frac{1}{2}W$	433-5622
R108	Res., C/F, 10K, $\pm 5\%$, $\frac{1}{2}W$	433-5102
R109	Res., Variable, 100K, Modified	145-1004
R110	Res., Variable, 100K, Modified	145-1004
R111	Res., Variable, 100K, Modified	145-1004
R112	Res., Variable, 100K, Modified	145-1004
S101	Switch, Mode	453-1014
S102	Switch, Tone	453-1015
S103	Switch, Lo Filter	453-1016
S104	Switch, Hi Filter	453-1016
PHONO AMP BOARD COMPONENT ASSEMBLY		
C201	Cap, 3600pf, $\pm 5\%$, 100V	385-1057
C202	Cap., 1100pf, $\pm 5\%$, 100V	385-1058
C203	Cap., 1.0uf, $\pm 20\%$, 250V	386-1008
C204	Cap., .03uf, $\pm 20\%$, 100V	383-1002
C205	Cap. Elect., 10uf, 25V	381-1034
C206	Cap., .03uf, $\pm 20\%$, 100V	383-1002
C207	Cap., 680pf, $\pm 5\%$, 100V	385-1042
C208	Cap., 210pf, $\pm 10\%$, 100V	385-1063
C209	Cap. Elect., 100uf, 10V	381-1031
C210	Cap. Elect., 220uf, 6.3V	381-1044
C211	Cap., 1.0uf, $\pm 20\%$, 250V	386-1008
C212	Cap., 39pf, $\pm 10\%$, 100V	385-1053
C213	Cap., 3600pf, $\pm 5\%$, 100V	385-1057

Reference Designation	Description and/or Remarks	Marantz Part Number
C214	Cap., 1100pf, $\pm 5\%$, 100V	385-1058
C215	Cap., 1.0uf, $\pm 20\%$, 250V	386-1008
C216	Cap., 1600pf, $\pm 10\%$, 100V	385-1044
C217	Cap Elect., 10uf, 25V	381-1034
C218	Cap., 39pf, $\pm 10\%$, 100V	385-1053
C219	Cap. Elect., 100uf, 10V	381-1031
C220	Cap., 210pf, $\pm 10\%$, 100V	385-1063
C221	Cap., 680pf, $\pm 5\%$, 100V	385-1042
C222	Cap. Elect., 220uf, 6.3V	381-1044
C223	Cap., 1600pf, $\pm 10\%$, 100V	385-1044
C224	Cap., 1.0uf, $\pm 20\%$, 250V	386-1008
C225	Cap., 1600pf, $\pm 10\%$, 100V	385-1044
C226	Cap., 1600pf, $\pm 10\%$, 100V	385-1044
CR201	Diode, Rectifier	460-1004
CR202	Diode, Rectifier	460-1004
R201	Res. Prec., 91K, $\pm 1\%$, $\frac{1}{4}W$	431-5910
R202	Res., C/F, 2.2Meg, $\pm 10\%$, $\frac{1}{4}W$	434-7223
R203	Res. Pres., 68K, $\pm 1\%$, $\frac{1}{4}W$	431-5680
R204	Res. Prec., 1.1 Meg, $\pm 2\%$, $\frac{1}{2}W$	439-1013
R205	Res., C/F, 2.2K, $\pm 5\%$, $\frac{1}{4}W$	434-4222
R206	Res. Prec., 100K, $\pm 2\%$, $\frac{1}{4}W$	431-6101
R207	Res., C/F, 18K, $\pm 5\%$, $\frac{1}{4}W$	434-5182
R208	Res., C/F, 270K, $\pm 5\%$, $\frac{1}{4}W$	434-6272
R209	Res., C/F, 22K, $\pm 5\%$, $\frac{1}{4}W$	434-5222
R210	Res. Prec., 680 ohm, $\pm 1\%$, $\frac{1}{4}W$	431-3680
R211	Res., C/F, 200 ohm, $\pm 5\%$, $\frac{1}{4}W$	434-3202
R212	Res. Prec., 1.1 Meg, $\pm 2\%$, $\frac{1}{2}W$	439-1013
R213	Res., C/F, 1 Meg, $\pm 5\%$, $\frac{1}{4}W$	434-7102
R214	Res., Variable, 25K, $\frac{1}{4}W$	420-1005
R215	Res., C/F, 100 ohm, $\pm 5\%$, $\frac{1}{4}W$	434-3102
R216	Res., C/F, 27K, $\pm 5\%$, $\frac{1}{4}W$	434-5272
R217	Res., C/F, 100 ohm, $\pm 5\%$, $\frac{1}{4}W$	434-3102
R218	Res., C/F, 3.9K, $\pm 5\%$, $\frac{1}{4}W$	434-4392
R219	Res., C/F, 150 ohm, $\pm 5\%$, $\frac{1}{4}W$	434-3152
R220	Res., C/F, 47K, $\pm 5\%$, $\frac{1}{4}W$	434-5472
R221	Res. Prec., 1.1 Meg, $\pm 2\%$, $\frac{1}{2}W$	439-1013
R222	Res., C/F, 2.2 Meg, $\pm 10\%$, $\frac{1}{4}W$	439-7223

Reference Designation	Description and/or Remarks	Marantz Part Number
R223	Res. Prec., 91K, $\pm 1\%$, $\frac{1}{4}W$	431-5910
R224	Res. Prec., 1.1 Meg, $\pm 2\%$, $\frac{1}{2}W$	439-1013
R225	Res. Prec., 68K, $\pm 1\%$, $\frac{1}{4}W$	431-5680
R226	Res. Prec., 100K, $\pm 2\%$, $\frac{1}{4}W$	431-6101
R227	Res., C/F, 2.2K, $\pm 5\%$, $\frac{1}{4}W$	434-4222
R228	Res., C/F, 270K, $\pm 5\%$, $\frac{1}{4}W$	434-6272
R229	Res., C/F, 18K, $\pm 5\%$, $\frac{1}{4}W$	434-5182
R230	Res., C/F, 22K, $\pm 5\%$, $\frac{1}{4}W$	434-5222
R231	Res. Prec., 680 ohm, $\pm 1\%$, $\frac{1}{4}W$	431-3680
R232	Res., C/F, 1 Meg, $\pm 5\%$, $\frac{1}{4}W$	434-7102
R233	Res. Prec., 1.1 Meg, $\pm 2\%$, $\frac{1}{2}W$	439-1013
R234	Res., C/F, 200 ohm, $\pm 5\%$, $\frac{1}{4}W$	434-3202
R235	Res., Variable, 25K, $\frac{1}{4}W$	420-1005
R236	Res., C/F, 27K, $\pm 5\%$, $\frac{1}{4}W$	434-5272
R237	Res., C/F, 100 ohm, $\pm 5\%$, $\frac{1}{4}W$	434-3102
R238	Res., C/F, 100 ohm, $\pm 5\%$, $\frac{1}{4}W$	434-3102
R239	Res., C/F, 3.9K, $\pm 5\%$, $\frac{1}{4}W$	434-4392
R240	Res., C/F, 150 ohm, $\pm 5\%$, $\frac{1}{4}W$	434-3152
R241	Res., C/F, 47K, $\pm 5\%$, $\frac{1}{4}W$	434-5472
R242	Res. Prec., 1.1 Meg, $\pm 2\%$, $\frac{1}{2}W$	439-1013
R243	Res., C/F, 30 ohm, $\pm 5\%$, $\frac{1}{4}W$	434-2302
R244	Res., C/F, 30 ohm, $\pm 5\%$, $\frac{1}{4}W$	434-2302
Q201	Transistor, NPN	462-1038
Q202	Transistor, NPN	462-1038
Q203	Transistor, PNP	461-1013
Q204	Transistor, NPN	462-1016
Q205	Transistor, NPN	462-1038
Q206	Transistor, NPN	462-1038
Q207	Transistor, PNP	461-1013
Q208	Transistor, NPN	462-1016
X 10 AMP BOARD COMPONENT ASSEMBLY		
C401	Cap., .03uf, $\pm 20\%$, 100V	383-1002
C402	Cap. Elect., 1uf, 63V	381-1036
C403	Cap. Elect., 1uf, 63V	381-1036
C404	Cap., .03uf, $\pm 20\%$, 100V	383-1002
C405	Cap. Elect., 47uf, 10V	381-1037

Reference Designation	Description and/or Remarks	Marantz Part Number
C406	Cap., 680pf, $\pm 5\%$, 100V	385-1042
C407	Cap. Elect., 1uf, 63V	381-1036
C408	Cap., 2000pf, $\pm 10\%$, 100V	385-1042
C409	Cap., 1100pf, $\pm 5\%$, 100V	385-1042
C410	Cap. Elect., 100uf, 10V	381-1031
C411	Cap., 100pf, $\pm 10\%$, 100V	385-1042
C412	Cap. Elect., 2.2uf, 40V	381-1031
C413	Cap. Elect., 1uf, 63V	381-1036
C414	Cap. Elect., 1uf, 63V	381-1036
C415	Cap. Elect., 47uf, 10V	381-1036
C416	Cap., 1100pf, $\pm 5\%$, 100V	385-1042
C417	Cap. Elect., 1uf, 63V	381-1036
C418	Cap., 680pf, $\pm 5\%$, 100V	385-1042
C419	Cap., 2000pf, $\pm 10\%$, 100V	385-1042
C420	Cap., 100pf, $\pm 10\%$, 100V	385-1042
C421	Cap. Elect., 100uf, 10V	381-1031
C422	Cap. Elect., 2.2uf, 40V	381-1031
CR401	Diode, Rectifier	460-1004
CR402	Diode, Rectifier	460-1004
R401	Res., C/F, 2.2K, $\pm 5\%$, $\frac{1}{2}W$	433-4222
R402	Res., C/F, 270K, $\pm 5\%$, $\frac{1}{2}W$	433-6272
R403	Res., C/F, 33K, $\pm 5\%$, $\frac{1}{4}W$	434-5336
R404	Res., C/F, 7.5K, $\pm 5\%$, $\frac{1}{4}W$	434-4756
R405	Res., C/F, 22K, $\pm 5\%$, $\frac{1}{4}W$	434-5222
R406	Res., C/F, 33K, $\pm 5\%$, $\frac{1}{4}W$	434-5336
R407	Res. Prec., 1.5K, $\pm 1\%$, $\frac{1}{4}W$	431-4156
R408	Res., C/F, 30 ohm, $\pm 5\%$, $\frac{1}{2}W$	433-2302
R409	Res. Prec., 15K, $\pm 1\%$, $\frac{1}{4}W$	431-5156
R410	Res., C/F, 56 ohm, $\pm 5\%$, $\frac{1}{2}W$	433-2566
R411	Res., C/F, 2.7K, $\pm 5\%$, $\frac{1}{4}W$	434-4272
R412	Res., C/F, 200 ohm, $\pm 5\%$, $\frac{1}{4}W$	434-3202
R413	Res., C/F, 30 ohm, $\pm 5\%$, $\frac{1}{4}W$	434-2302
R414	Res., C/F, 2.2K, $\pm 5\%$, $\frac{1}{4}W$	434-4222
R415	Res., C/F, 33K, $\pm 5\%$, $\frac{1}{4}W$	434-5336
R416	Res., C/F, 270K, $\pm 5\%$, $\frac{1}{4}W$	434-6272
R417	Res., C/F, 7.5K, $\pm 5\%$, $\frac{1}{4}W$	434-4756
R418	Res., C/F, 22K, $\pm 5\%$, $\frac{1}{4}W$	434-5222

Reference Designation	Description and/or Remarks	Marantz Part Number
223	Res. Prec., 91K, ±1%, ¼W	431-5910
224	Res. Prec., 1.1 Meg, ±2%, ½W	439-1013
225	Res. Prec., 68K, ±1%, ¼W	431-5680
226	Res. Prec., 100K, ±2%, ¼W	431-6101
227	Res., C/F, 2.2K, ±5%, ¼W	434-4222
228	Res., C/F, 270K, ±5%, ¼W	434-6272
229	Res., C/F, 18K, ±5%, ¼W	434-5182
230	Res., C/F, 22K, ±5%, ¼W	434-5222
231	Res. Prec., 680 ohm, ±1%, ¼W	431-3680
232	Res., C/F, 1 Meg, ±5%, ¼W	434-7102
233	Res. Prec., 1.1 Meg, ±2%, ½W	439-1013
234	Res., C/F, 200 ohm, ±5%, ¼W	434-3202
235	Res., Variable, 25K, ¼W	420-1005
236	Res., C/F, 27K, ±5%, ¼W	434-5272
237	Res., C/F, 100 ohm, ±5%, ¼W	434-3102
238	Res., C/F, 100 ohm, ±5%, ¼W	434-3102
239	Res., C/F, 3.9K, ±5%, ¼W	434-4392
240	Res., C/F, 150 ohm, ±5%, ¼W	434-3152
241	Res., C/F, 47K, ±5%, ¼W	434-5472
242	Res. Prec., 1.1 Meg, ±2%, ½W	439-1013
243	Res., C/F, 30 ohm, ±5%, ¼W	434-2302
244	Res., C/F, 30 ohm, ±5%, ¼W	434-2302
201	Transistor, NPN	462-1038
202	Transistor, NPN	462-1038
203	Transistor, PNP	461-1013
204	Transistor, NPN	462-1016
205	Transistor, NPN	462-1038
206	Transistor, NPN	462-1038
207	Transistor, PNP	461-1013
208	Transistor, NPN	462-1016
X 10 AMP BOARD COMPONENT ASSEMBLY		
01	Cap., .03uf, ±20%, 100V	383-1002
02	Cap. Elect., 1uf, 63V	381-1036
03	Cap. Elect., 1uf, 63V	381-1036
04	Cap., .03uf, ±20%, 100V	383-1002
05	Cap. Elect., 47uf, 10V	381-1037

Reference Designation	Description and/or Remarks	Marantz Part Number
C406	Cap., 680pf, ±5%, 100V	385-1042
C407	Cap. Elect., 1uf, 63V	381-1036
C408	Cap., 2000pf, ±10%, 100V	385-1046
C409	Cap., 1100pf, ±5%, 100V	385-1058
C410	Cap. Elect., 100uf, 10V	381-1031
C411	Cap., 100pf, ±10%, 100V	385-1041
C412	Cap. Elect., 2.2uf, 40V	381-1038
C413	Cap. Elect., 1uf, 63V	381-1036
C414	Cap. Elect., 1uf, 63V	381-1036
C415	Cap. Elect., 47uf, 10V	381-1037
C416	Cap., 1100pf, ±5%, 100V	385-1058
C417	Cap. Elect., 1uf, 63V	381-1036
C418	Cap., 680pf, ±5%, 100V	385-1042
C419	Cap., 2000pf, ±10%, 100V	385-1046
C420	Cap., 100pf, ±10%, 100V	385-1041
C421	Cap. Elect., 100uf, 10V	381-1031
C422	Cap. Elect., 2.2uf, 40V	381-1038
CR401	Diode, Rectifier	460-1009
CR402	Diode, Rectifier	460-1009
R401	Res., C/F, 2.2K, ±5%, ½W	433-4222
R402	Res., C/F, 270K, ±5%, ½W	433-6272
R403	Res., C/F, 33K, ±5%, ¼W	434-5332
R404	Res., C/F, 7.5K, ±5%, ¼W	434-4752
R405	Res., C/F, 22K, ±5%, ¼W	434-5222
R406	Res., C/F, 33K, ±5%, ¼W	434-5332
R407	Res. Prec., 1.5K, ±1%, ¼W	431-4150
R408	Res., C/F, 30 ohm, ±5%, ½W	433-2302
R409	Res. Prec., 15K, ±1%, ¼W	431-5150
R410	Res., C/F, 56 ohm, ±5%, ½W	433-2562
R411	Res., C/F, 2.7K, ±5%, ¼W	434-4272
R412	Res., C/F, 200 ohm, ±5%, ¼W	434-3202
R413	Res., C/F, 30 ohm, ±5%, ¼W	434-2302
R414	Res., C/F, 2.2K, ±5%, ¼W	434-4222
R415	Res., C/F, 33K, ±5%, ¼W	434-5332
R416	Res., C/F, 270K, ±5%, ¼W	434-6272
R417	Res., C/F, 7.5K, ±5%, ¼W	434-4752
R418	Res., C/F, 22K, ±5%, ¼W	434-5222

Reference Designation	Description and/or Remarks	Marantz Part Number
R419	Res., C/F, 33K, ±5%, ¼W	434-5332
R420	Res. Prec., 1.5K, ±1%, ¼W	431-4150
R421	Res., C/F, 200 ohm, ±5%, ¼W	434-3202
R422	Res. Prec., 15K, ±1%, ¼W	431-5150
R423	Res., C/F, 30 ohm, ±5%, ¼W	434-2302
R424	Res., C/F, 200 ohm, ±5%, ¼W	434-3202
R425	Res., C/F, 2.7K, ±5%, ¼W	434-4272
R426	Res., C/F, 56 ohm, ±5%, ¼W	434-2562
Q401	Transistor, NPN	462-1038
Q402	Transistor, NPN	462-1038
Q403	Transistor, PNP	461-1013
Q404	Transistor, NPN	462-1038
Q405	Transistor, NPN	462-1038
Q406	Transistor, PNP	461-1013
TONE AMP BOARD COMPONENT ASSEMBLY		
C301	Cap. Elect., 1uf, 63V	381-1036
C302	Cap., .033uf, ±20%, 100V	385-1022
C303	Cap., .033uf, ±20%, 100V	385-1022
C304	Cap., .001uf, ±10%, 100V	385-1023
C305	Cap., 27pf, ±10%, 100V	385-1036
C306	Cap., .03uf, ±20%, 100V	383-1002
C307	Cap., 680pf, ±5%, 100V	385-1042
C308	Cap. Elect., 10uf, 25V	381-1034
C309	Cap., 1uf, ±20%, 250V	386-1008
C310	Cap., .03uf, ±20%, 100V	383-1002
C311	Cap. Elect., 1uf, 63V	381-1036
C312	Cap., .033uf, ±20%, 100V	385-1022
C313	Cap., .033uf, ±20%, 100V	385-1022
C314	Cap., .001uf, ±10%, 100V	385-1023
C315	Cap., 27pf, ±10%, 100V	385-1036
C316	Cap., 680pf, ±5%, 100V	385-1042
C317	Cap. Elect., 10uf, 25V	381-1034
C318	Cap., 1uf, ±20%, 250V	386-1008
R301	Res., C/F, 270K, ±5%, ¼W	434-6272
R302	Res., C/F, 18K, ±5%, ¼W	434-5182

Reference Designation	Description and/or Remarks	Marantz Part Number
R303	Res., C/F, 10K, ±5%, ¼W	434-5102
R304	Res., C/F, 18K, ±5%, ½W	433-5182
R305	Res., C/F, 10K, ±5%, ¼W	434-5102
R306	Res., C/F, 27K, ±5%, ½W	433-5272
R307	Res., C/F, 1 Meg, ±5%, ¼W	434-7102
R308	Res., C/F, 22K, ±5%, ¼W	434-5222
R309	Res., C/F, 7.5K, ±5%, ¼W	434-4752
R310	Res., C/F, 30 ohm, ±5%, ¼W	434-2302
R311	Res., C/F, 39K, ±5%, ¼W	434-5392
C312	Res., C/F, 56 ohm, ±5%, ¼W	434-2562
R313	Res., C/F, 2.7K, ±5%, ¼W	434-4272
R314	Res., C/F, 300 ohm, ±5%, ½W	433-3302
R315	Res., C/F, 270K, ±5%, ¼W	434-6272
R316	Res., C/F, 270K, ±5%, ¼W	434-6272
R317	Res., C/F, 10K, ±5%, ¼W	434-5102
R318	Res., C/F, 18K, ±5%, ¼W	434-5182
R319	Res., C/F, 10K, ±5%, ¼W	434-5102
R320	Res., C/F, 18K, ±5%, ¼W	434-5182
R321	Res., C/F, 27K, ±5%, ¼W	434-5272
R322	Res., C/F, 1 Meg, ±5%, ¼W	434-7102
R323	Res., C/F, 22K, ±5%, ¼W	434-5222
R324	Res., C/F, 7.5K, ±5%, ¼W	434-4752
R325	Res., C/F, 39K, ±5%, ¼W	434-5392
R326	Res., C/F, 30 ohm, ±5%, ¼W	434-2302
R327	Res., C/F, 2.7K, ±5%, ¼W	434-4272
R328	Res., C/F, 56 ohm, ±5%, ¼W	434-2562
R329	Res., C/F, 270K, ±5%, ¼W	433-6272
R330	Res., C/F, 300 ohm, ±5%, ¼W	434-3302
Q301	Transistor, NPN	462-1038
Q302	Transistor, NPN	462-1038
Q303	Transistor, PNP	461-1013
Q304	Transistor, NPN	462-1038
Q305	Transistor, NPN	462-1038
Q306	Transistor, PNP	461-1013
POWER AMPLIFIER BOARD COMPONENT ASSEMBLY		
	Transistor Socket	368-1000

PARTS LIST

Reference Designation	Description and/or Remarks	Marantz Part Number
L501	Toroid	147-1007
C501	Cap., 150pf, ±10%, 100V	385-1038
C502	Cap. Elect., 10uf, 25V	381-1034
C503	Cap. Elect., 10uf, 25V	381-1034
C504	Cap. Elect., 10uf, 25V	381-1034
C505	Cap., 47pf, ±10%, 100V	385-1040
C506	Cap., 680pf, ±5%, 100V	385-1042
C507	Cap. Elect., 220uf, 6.3V	381-1044
C508	Cap., 36 pf, ±5%, 100V	385-1064
C509	Cap., 36pf, ±5%, 300V	385-1018
C510	Cap., 0.1uf, ±10%, 250V	386-1000
C511	Cap., 0.1uf, ±10%, 250V	386-1000
C512	Cap., 410pf, ±10%, 100V	385-1055
C513	Cap., 0.22uf, ±10%, 250V	386-1017
C514	Cap., 1600pf, ±10%, 300V	385-1020
C515	Cap., 1600pf, ±10%, 300V	385-1020
C516	Cap., 0.1uf, ±10%, 250V	386-1000
C517	Cap., 1.0uf, ±20%, 100V	388-1001
C518	Cap., 130pf, ±10%, 300V	385-1019
CR501	Diode, Zener	459-1006
CR502	Diode, Zener	459-1006
R501	Res., C/F, 7.5K, ±5%, ½W	433-4752
R502	Res., Variable, 2K, 2W	420-1000
R503	Res., C/F, 4.7K, ±5%, ½W	433-4472
R504	Res., C/F, 100K, ±5%, ¼W	434-6102
R505	Res., C/F, 470K, ±5%, ¼W	434-6472
R506	Res., C/F, 1K, ±5%, ¼W	434-4102
R507	Res., C/F, 100K, ±5%, ¼W	434-6102
R508	Res., C/F, 7.5K, ±5%, ½W	433-4752
R509	Res., C/F, 3.3K, ±5%, ¼W	434-4332
R510	Res., C/F, 8.2K, ±5%, ¼W	434-4822
R511	Res., C/F, 680 ohm, ±5%, ¼W	434-3682
R512	Res., C/F, 7.5K, ±5%, ½W	433-4752
R513	Res. Prec., 1K, ±1%, ¼W	431-4100
R514	Res., C/F, 2K, ±5%, ¼W	434-4202
R515	Res., C/F, 27 ohm, ±5%, ½W	433-2272
R516	Res., C/F, 220 ohm, ±5%, ¼W	434-3222

Reference Designation	Description and/or Remarks	Marantz Part Number
R517	Res., W/W, 1.2K, ±10%, 2W	436-4123
R518	Res., W/W, 1.2K, ±10%, 2W	436-4123
R519	Res. Prec., 20K, ±1%, ¼W	431-5200
R520	Res., C/F, 100K, ±5%, ¼W	434-6102
R521	Res., C/F, 300 ohm, ±5%, ¼W	434-3302
R522	Res., C/F, 560 ohm, ±5%, ½W	433-3562
R523	Res., C/F, 560 ohm, ±5%, ½W	433-3562
R524	Res., C/F, 27K, ±5%, ¼W	434-5272
R525	Res., C/F, 27K, ±5%, ¼W	434-5272
R526	Res., Variable, 1K, 2W	420-1011
R527	Res., C/F, 47 ohm, ±5%, ½W	433-2472
R528	Res., C/F, 47 ohm, ±5%, ½W	433-2472
R529	Res., C/C, 39 ohm, ±10%, 1W	423-2392
R530	Res., C/C, 39 ohm, ±10%, 1W	423-2392
R531	Res., W/W, 0.1ohm, ±5%, 5W	145-1002
R532	Res., W/W, 0.1 ohm, ±5%, 5W	145-1002
R533	Res., W/W, 0.15 ohm, ±10%, 5W	428-0153
R534	Res., W/W, 0.15 ohm, ±10%, 5W	428-0153
R535	Res., W/W, 0.15 ohm, ±10%, 5W	428-0153
R536	Res., W/W, 0.15 ohm, ±10%, 5W	428-0153
R537	Res., C/F, 330 ohm, ±5%, ¼W	434-3332
R538	Res., C/F, 330 ohm, ±5%, ¼W	434-3332
R539	Res., C/C, 27 ohm, ±5%, 2W	424-2272
R540	Res., C/F, 2.2K, ±5%, ½W	433-4222
R541	Res., Variable, 2.5K, ¼W	420-1019
R542	Res., Variable, 2.5K, ¼W	420-1019
R543	Res., C/F, 2.2K, ±5%, ½W	433-4222
R544	Res., C/F, 1K, ±5%, ½W	433-4102
R545	Res., C/F, 1K, ±5%, ½W	433-4102
R546	Res., BWH, 1.0 ohm, ±5%, 2W	436-1102
R547	Res., C/F, 2.2K, ±5%, ¼W	434-4222
R548	Res., C/F, 2.7K, ±5%, ¼W	434-4272
R549	Res., C/F, 10K, ±5%, ¼W	434-5102
R550	Res., C/F, 1K, ±5%, ¼W	434-4102
R551	Res., C/F, 270K, ±5%, ¼W	434-6272
Q501	Transistor, NPN	462-1038
Q502	Transistor, NPN	462-1038
Q503	Transistor, PNP	461-1037

Reference Designation	Description and/or Remarks	Marantz Part Number
Q504	Transistor, NPN	462-1044
Q505	Transistor, PNP	461-1036
Q506	Transistor, NPN	462-1042
Q507	Transistor, PNP	461-1003
Q508	Transistor, NPN	462-1004
Q509	Not used	
Q510	Transistor, NPN	462-1040
Q511	Transistor, PNP	461-1034
Q512	Not used	
Q513	Not used	
Q514	Not used	
Q515	Not used	
Q516	Transistor, NPN	462-1035
Q517	Transistor, PNP	461-1030
Q518	Transistor, PNP	461-1013
Q519	Transistor, PNP	461-1013
Q802	Transistor, PNP	461-1031
Q803	Transistor, NPN	462-1036
Q804	Transistor, PNP	461-1031
Q805	Transistor, NPN	462-1036
C801	Cap., 0.1uf, ±10%, 250V	386-1000
CR801	Diode	460-1011
Q801	Transistor, NPN	462-1043
	Heat Sensor Assy.	215-1006-1
	POWER SUPPLY BOARD COMPONENT ASSEMBLY	
C601	Cap. Elect., 470uf, 40V	381-1022
C602	Cap. Elect., 470uf, 40V	381-1022
C603	Cap. Elect., 470uf, 40V	381-1022
C604	Cap. Elect., 100uf, 40V	381-1013
C605	Cap. Elect., 100uf, 40V	381-1013
C606	Cap. Elect., 470uf, 40V	381-1022
C607	Cap. Elect., 470uf, 40 V	381-1022
C608	Cap. Elect., 470uf, 40V	381-1022
C609	Cap. Elect., 680uf, 16V	381-1008
C610	Cap. Elect., 680uf, 16V	381-1008
C611	Cap. Elect., 680uf, 16V	381-1008

Reference Designation	Description and/or Remarks	Marantz Part N
C612	Cap. Elect., 680uf, 16V	381-
CR601	Diode	460-
CR602	Diode	460-
CR603	Diode	460-
CR604	Diode	460-
CR605	Diode, Zener	459-
CR606	Diode, Zener	459-
R601	Res., C/F, 10 ohm, ±5%, ½W	433-2
R602	Res., C/F, 10 ohm, ±5%, ½W	433-2
R603	Res., C/F, 10 ohm, ±5%, ½W	433-2
R604	Res., C/F, 10 ohm, ±5%, ½W	433-2
R605	Res., C/F, 240 ohm, ±5%, ½W	433-3
R606	Res., C/F, 750 ohm, ±5%, ½W	433-3
R607	Res., C/F, 750 ohm, ±5%, ½W	433-3
R608	Res., C/F, 240 ohm, ±5%, ½W	433-3
R609	Res., C/F, 200 ohm, ±5%, ½W	433-3
R610	Res., C/F, 200 ohm, ±5%, ½W	433-3
R611	Res., C/F, 120 ohm, ±5%, ½W	433-3
R612	Res., C/F, 120 ohm, ±5%, ½W	433-3
Q601	Transistor, NPN	462-1
Q602	Transistor, PNP	461-1
	RECTIFIER/RELAY BOARD COMPONENT ASSEMBLY	
C701	Cap. Elect., 22uf, 25V	381-1
C702	Cap. Elect., 220uf, 6.3V	381-1
C703	Not used	
C704	Not used	
C705	Cap. Elect., 22uf, 63V	381-11
CR701	Diode	460-10
CR702	Diode	460-10
CR703	Diode	460-10
CR704	Diode	460-10
CR705	Diode	460-10
CR706	Diode	460-10
CR707	Diode, Zener	459-10
	Chassis, Fastener	568-10

Reference Designation	Description and/or Remarks	Marantz Part Number
1504	Transistor, NPN	462-1044
1505	Transistor, PNP	461-1036
1506	Transistor, NPN	462-1042
1507	Transistor, PNP	461-1003
1508	Transistor, NPN	462-1004
1509	Not used	
1510	Transistor, NPN	462-1040
1511	Transistor, PNP	461-1034
1512	Not used	
1513	Not used	
1514	Not used	
1515	Not used	
1516	Transistor, NPN	462-1035
1517	Transistor, PNP	461-1030
1518	Transistor, PNP	461-1013
1519	Transistor, PNP	461-1013
1802	Transistor, PNP	461-1031
1803	Transistor, NPN	462-1036
1804	Transistor, PNP	461-1031
1805	Transistor, NPN	462-1036
1801	Cap., 0.1uf, ±10%, 250V	386-1000
1801	Diode	460-1011
1801	Transistor, NPN	462-1043
	Heat Sensor Assy.	215-1006-1
	POWER SUPPLY BOARD COMPONENT ASSEMBLY	
1601	Cap. Elect., 470uf, 40V	381-1022
1602	Cap. Elect., 470uf, 40V	381-1022
1603	Cap. Elect., 470uf, 40V	381-1022
1604	Cap. Elect., 100uf, 40V	381-1013
1605	Cap. Elect., 100uf, 40V	381-1013
1606	Cap. Elect., 470uf, 40V	381-1022
1607	Cap. Elect., 470uf, 40V	381-1022
1608	Cap. Elect., 470uf, 40V	381-1022
1609	Cap. Elect., 680uf, 16V	381-1008
1610	Cap. Elect., 680uf, 16V	381-1008
1611	Cap. Elect., 680uf, 16V	381-1008

Reference Designation	Description and/or Remarks	Marantz Part Number
C612	Cap. Elect., 680uf, 16V	381-1008
CR601	Diode	460-1013
CR602	Diode	460-1013
CR603	Diode	460-1013
CR604	Diode	460-1013
CR605	Diode, Zener	459-1001
CR606	Diode, Zener	459-1001
R601	Res., C/F, 10 ohm, ±5%, ½W	433-2102
R602	Res., C/F, 10 ohm, ±5%, ½W	433-2102
R603	Res., C/F, 10 ohm, ±5%, ½W	433-2102
R604	Res., C/F, 10 ohm, ±5%, ½W	433-2102
R605	Res., C/F, 240 ohm, ±5%, ½W	433-3242
R606	Res., C/F, 750 ohm, ±5%, ½W	433-3752
R607	Res., C/F, 750 ohm, ±5%, ½W	433-3752
R608	Res., C/F, 240 ohm, ±5%, ½W	433-3242
R609	Res., C/F, 200 ohm, ±5%, ½W	433-3202
R610	Res., C/F, 200 ohm, ±5%, ½W	433-3202
R611	Res., C/F, 120 ohm, ±5%, ½W	433-3122
R612	Res., C/F, 120 ohm, ±5%, ½W	433-3122
Q601	Transistor, NPN	462-1019
Q602	Transistor, PNP	461-1014
	RECTIFIER/RELAY BOARD COMPONENT ASSEMBLY	
C701	Cap. Elect., 22uf, 25V	381-1046
C702	Cap. Elect., 220uf, 6.3V	381-1044
C703	Not used	
C704	Not used	
C705	Cap. Elect., 22uf, 63V	381-1040
CR701	Diode	460-1014
CR702	Diode	460-1014
CR703	Diode	460-1014
CR704	Diode	460-1014
CR705	Diode	460-1013
CR706	Diode	460-1013
CR707	Diode, Zener	459-1005
	Chassis, Fastener	568-1000

Reference Designation	Description and/or Remarks	Marantz Part Number
K701	Relay, DPDT	410-1000
R701	Res., C/F, 10K, ±5%, ½W	433-5102
R702	Res., C/F, 7.5K, ±5%, ½W	433-4752
R703	Res., C/F, 75K, ±5%, ½W	433-5752
R704	Res., C/F, 82K, ±5%, ½W	433-5822
R705	Res., C/F, 15K, ±5%, ½W	433-5152
R706	Res., C/F, 27K, ±5%, ½W	433-5272
R707	Res., C/F, 180K, ±5%, ½W	433-6182
R708	Res., W/W, 430 ohm, ±5%, 5W	428-3432
R709	Res., W/W, 2.2K, ±5%, 2W	436-4222
R710	Res., W/W, 2.2K, ±5%, 2W	436-4222
R711	Res., W/W, 220 ohm, ±10%, 2W	436-3223
R712	Res., C/C, 120 ohm, ±5%, 1W	423-3122
R713	Res., C/C, 120 ohm, ±5%, 1W	423-3122
R714	Res., C/F, 22K, ±5%, ½W	433-5222
R715	Res., C/F, 22K, ±5%, ½W	433-5222
Q701	Transistor, NPN	462-1000
Q702	Transistor, NPN	462-1007
Q703	Transistor, NPN	462-1000
	CHASSIS ASSEMBLY	
C4	Cap., Elect., 20,000uf, 60V	381-1041
C5	Cap., Elect., 20,000uf, 60V	381-1041
C1	Cap., .01uf, -20%, 1400V +80%	383-1006
C2	Cap., .01uf, -20%, 1400V +80%	383-1006
C3	Cap., .01uf, -20%, 1400V +80%	383-1006
C6	Cap., 330pf, ±10%, 100V	385-1062
C7	Cap., 330pf, ±10%, 100V	385-1062
R1	Res., C/F, 56K, ±5%, 1/2W	433-5562
R2	Res., C/F, 56K, ±5%, 1/2W	433-5562
R3	Res., C/F, 56K, ±5%, 1/2W	433-5562
R4	Res., C/F, 56K, ±5%, 1/2W	433-5562
R5	Res., C/F, 22K, ±5%, 1/2W	433-5222
R6	Res., C/F, 10K, ±5%, 1/2W	433-5102

Reference Designation	Description and/or Remarks	Marantz Part Number
R7	Res., C/F, 22K, ±5%, 1/2W	433-5222
R8	Res., C/F, 10K, ±5%, 1/2W	433-5102
R9	Res., C/F, 100K, ±5%, 1/4W	434-6102
R10	Res., C/F, 100K, ±5%, 1/4W	434-6102
R11	Res., Variable, 100K, 2W	420-1015
T1	Transformer, Power	440-1007
F1	Fuse, 6 Amp, 250V	451-1013
S1	Switch, Selector	453-1000
S2	Switch, Tape Monitor	453-1006
S3	Switch, Slide	452-1002
S4	Switch, Power	452-1004
S5	Switch, Speaker	453-1003
XDS1	Socket Assy., Light Foot, Plastic	481-1002 567-1000
TB2, TB3	Speaker Terminal Strip	362-1002

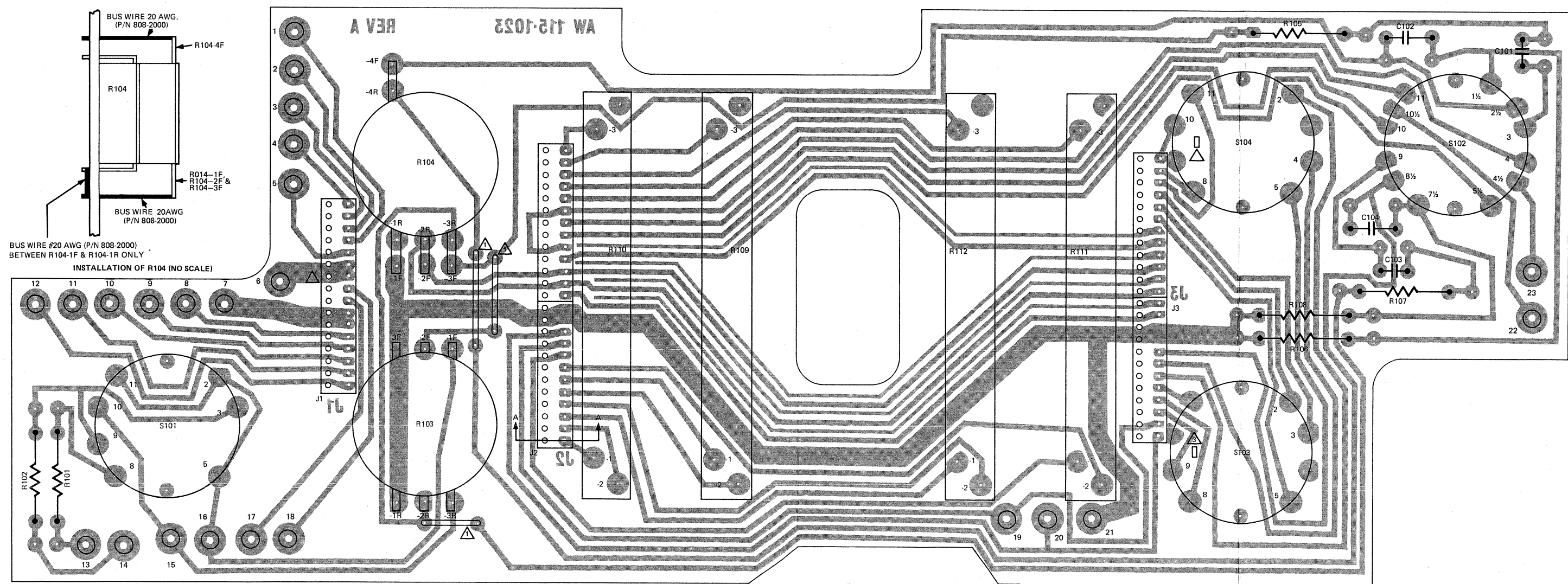

COMPONENT SIDE SHOWN
CONDUCTOR SIDE OPPOSITE

Figure 13. Interconnect Board – A1 Component Assembly Diagram

X

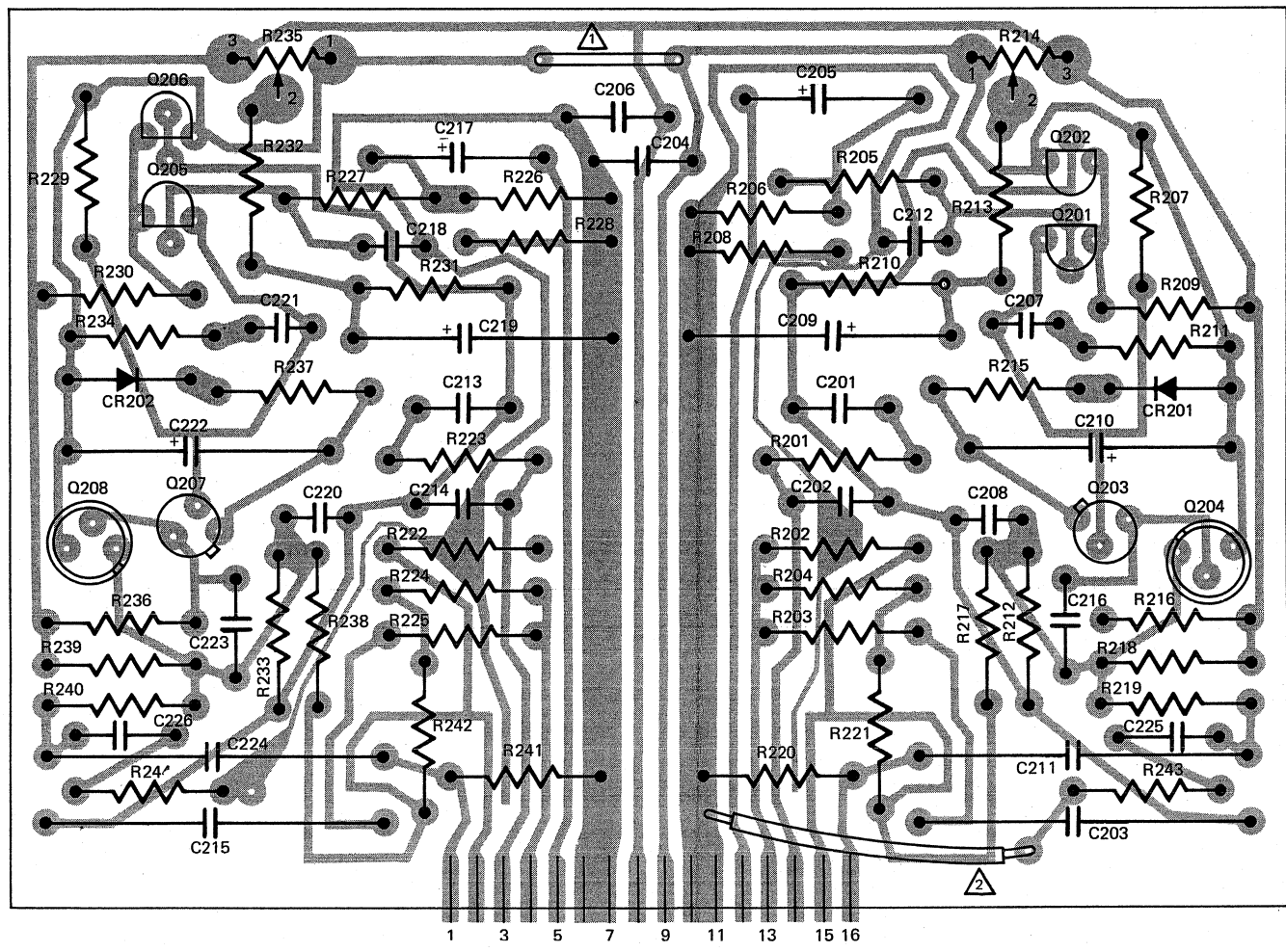

Figure 14. Phono Amplifier Board - A2 Component Assembly Diagram

X

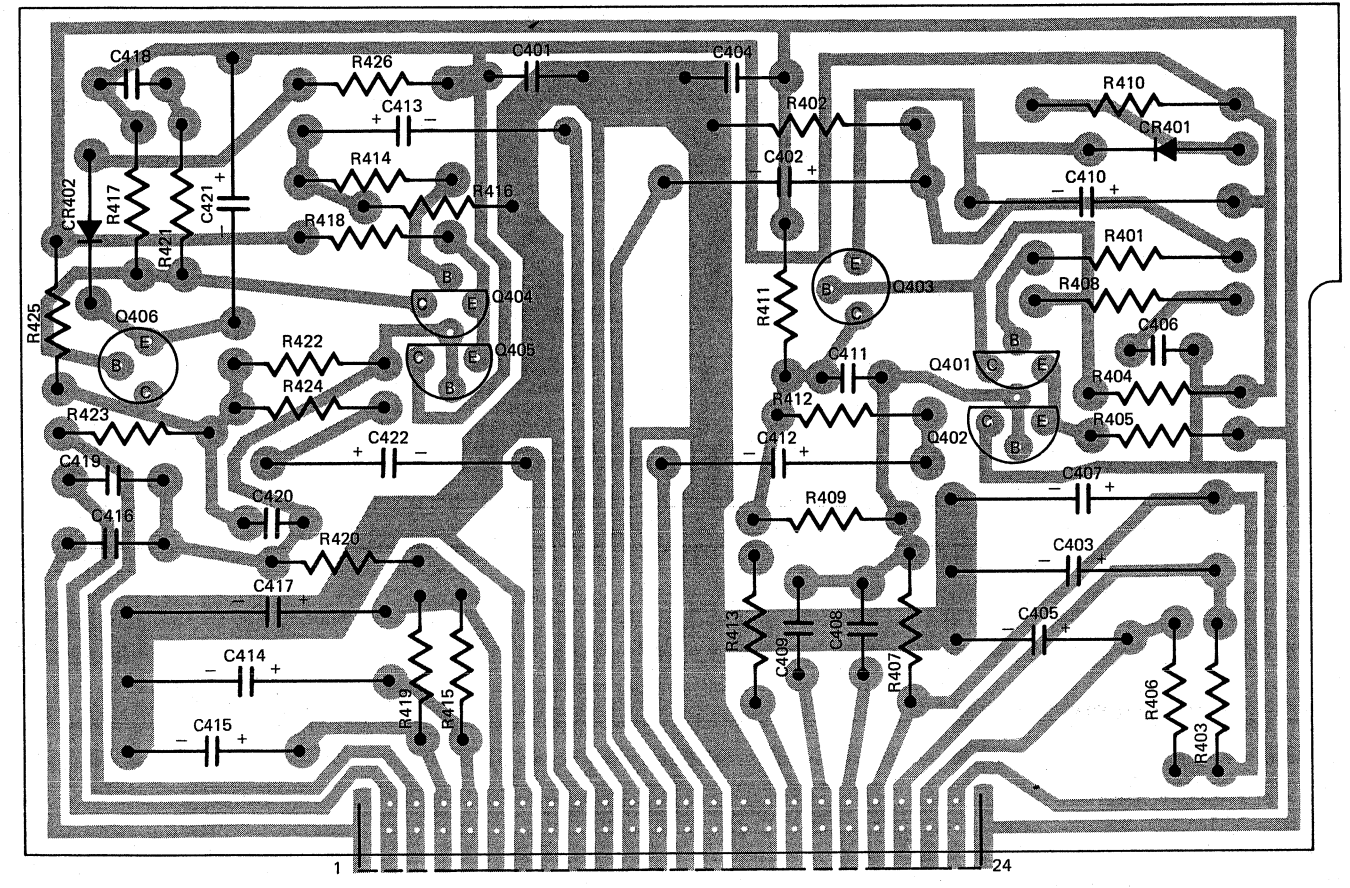

Figure 15. X10 Amplifier Board - A3 Component Assembly Diagram

Figure 16. Tone Amplifier Board – A4 Component Assembly Diagram

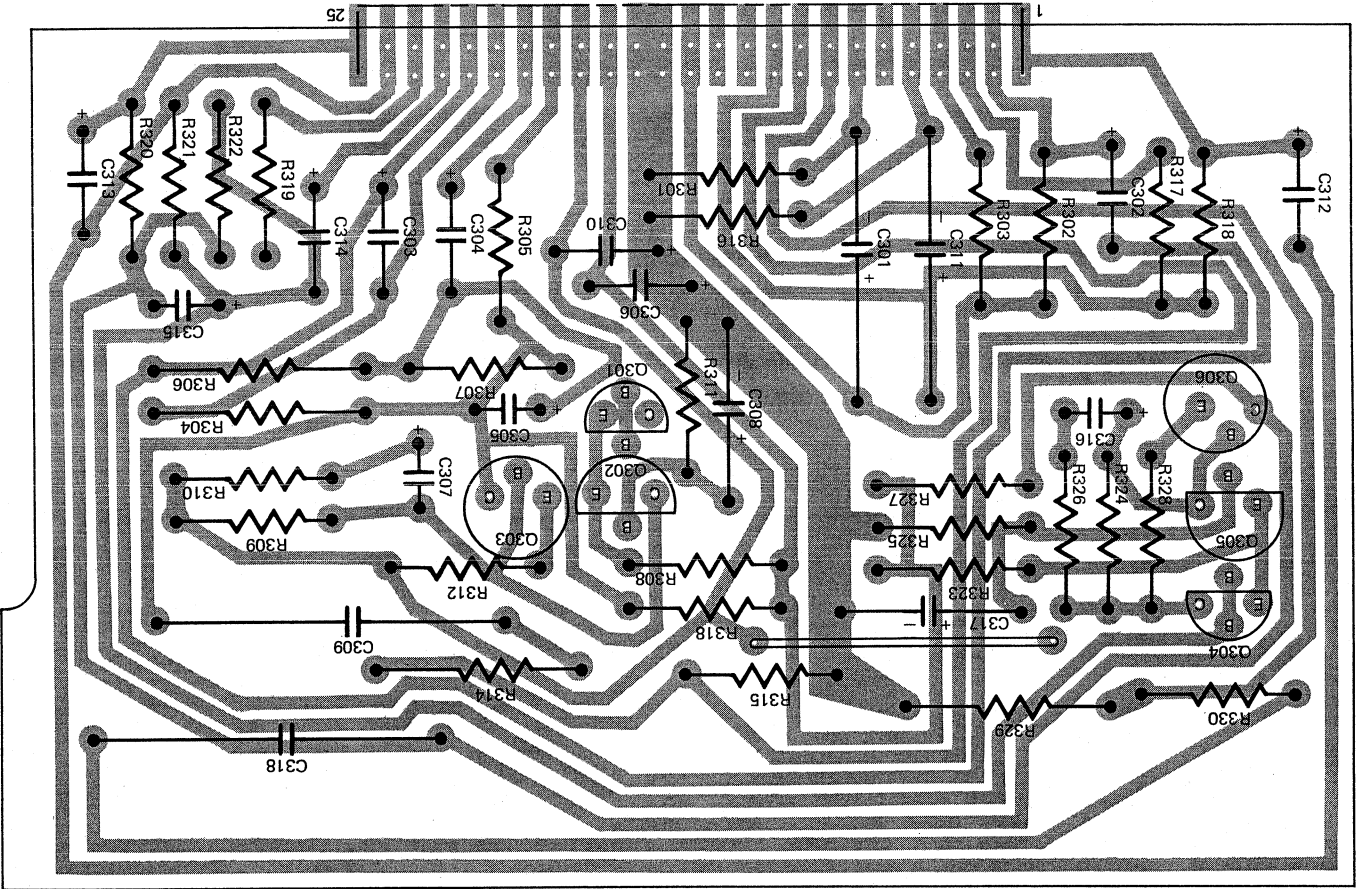

Figure 17. Power Amplifier Board – A5/A6 Component Assembly Diagram

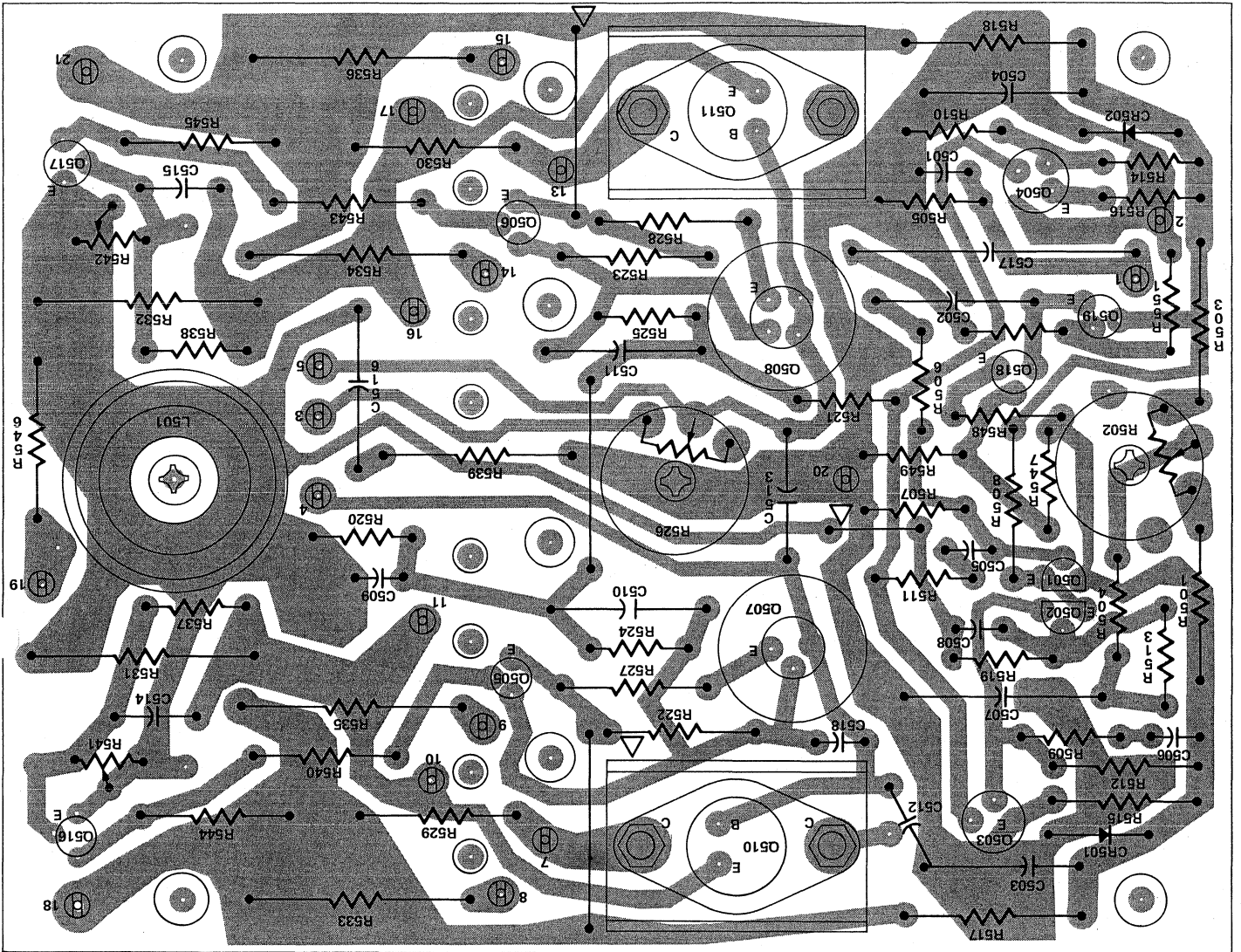

Figure 18. Power Supply Board – A7 Component Assembly Diagram

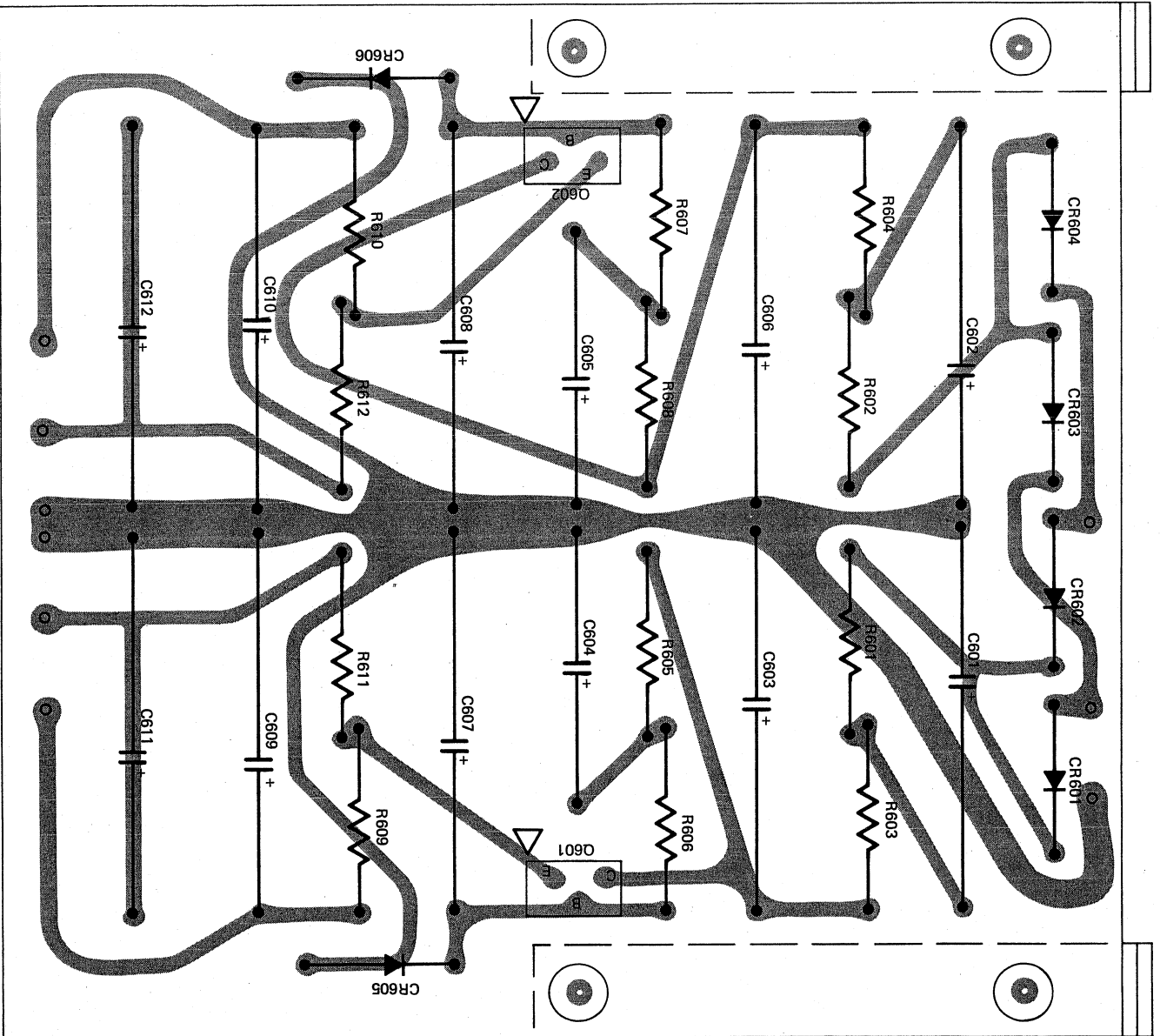
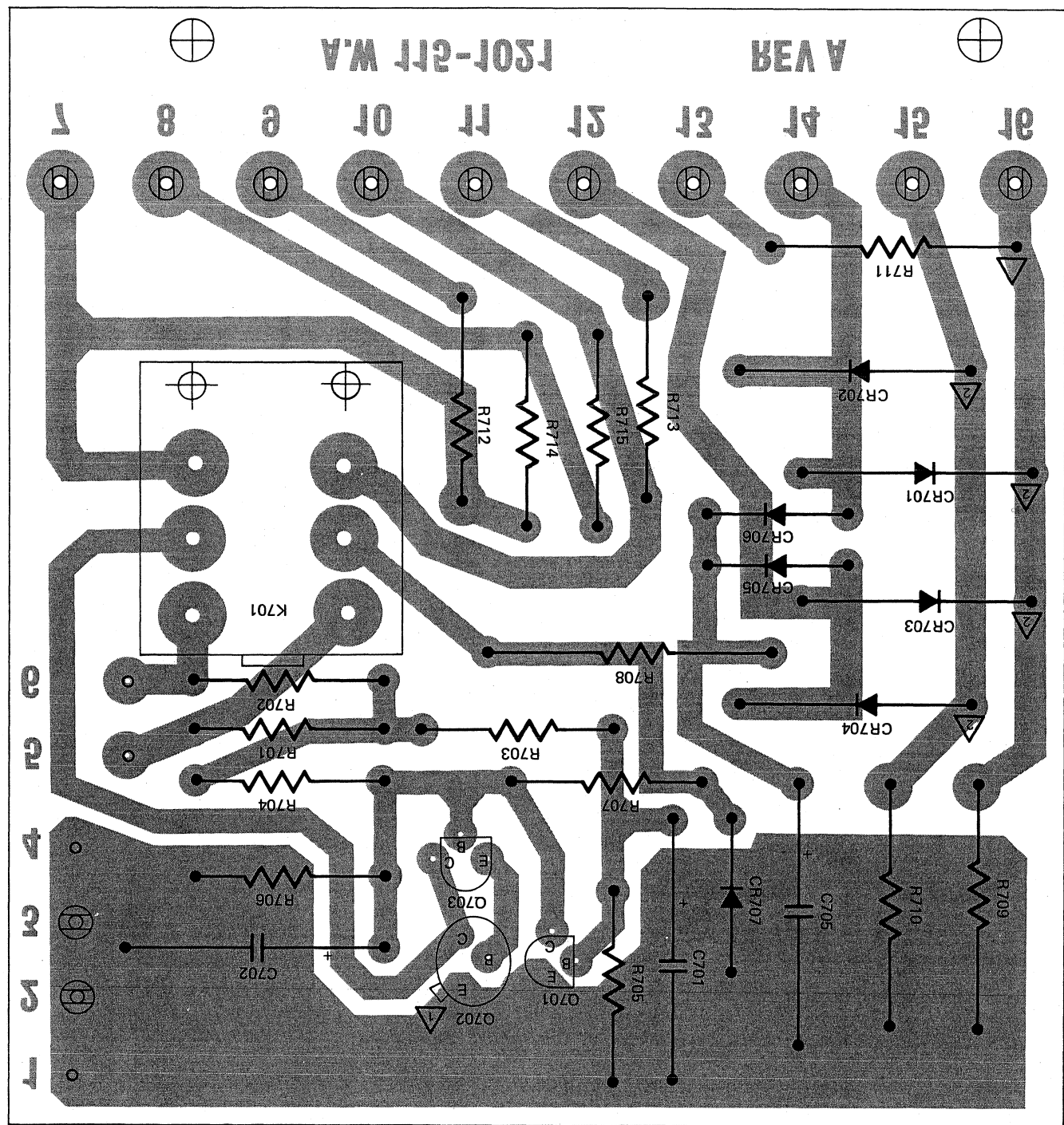
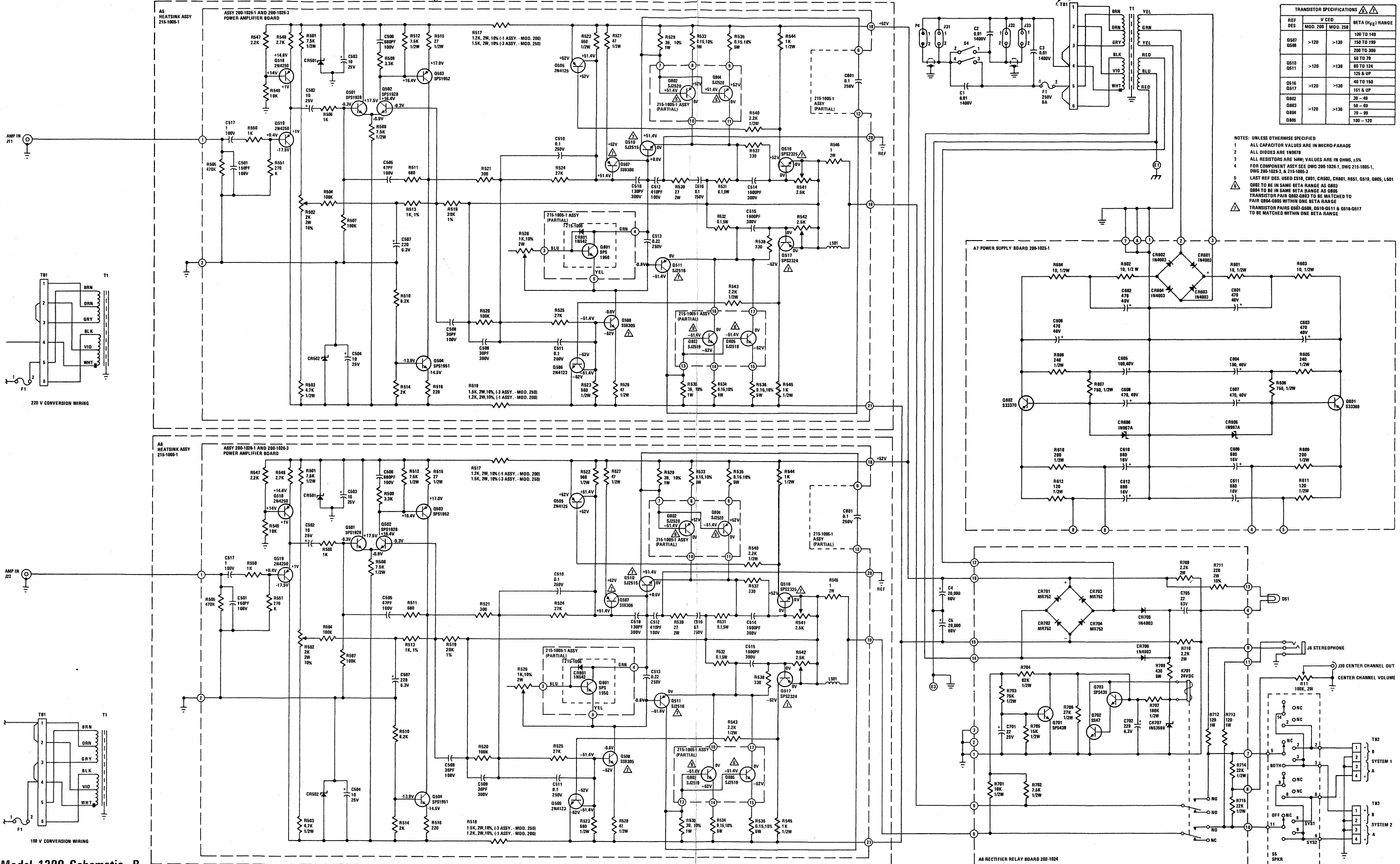

Figure 19. Rectifier/Relay Board - A8 Component Assembly Diagram





REF DES	V _{CE}		BETA (H _{FE}) RANGE
	MOD. 200	MOD. 250	
Q507	>120	>120	100 TO 140
Q508			150 TO 180
			200 TO 300
Q510	>120	>130	80 TO 70
Q511			80 TO 120
			125 TO 150
Q512	>120	>130	40 TO 160
Q513			150 TO 180
Q514	>120	>130	30 - 40
Q515			50 - 80
Q516	>120	>130	70 - 90
Q517			100 - 120

NOTES: UNLESS OTHERWISE SPECIFIED
 1 ALL CAPACITOR VALUES ARE IN MICROFARADS
 2 ALL DIODES ARE 1N907B
 3 ALL RESISTORS ARE 5% VALUES ARE IN OHMS, Ω%
 4 FOR COMPONENT ASSY SEE DWG 200-1025-1, DWG 215-1005-1, DWG 200-1024-1, & 215-1005-3
 5 LAST REF DES. USED C518, C801, CR802, CR803, R501, Q510, Q505, L501
 Q502 TO BE IN SAME BETA RANGE AS Q503
 Q504 TO BE IN SAME BETA RANGE AS Q505
 TRANSISTOR PAIR Q502-Q503 TO BE MATCHED TO PAIR Q504-Q505 WITHIN ONE BETA RANGE
 TRANSISTOR PAIR Q507-Q508, Q510-Q511 & Q512-Q513 TO BE MATCHED WITHIN ONE BETA RANGE

Figure 21. Model 1200 Schematic, B

ADDENDUM FOR MODEL 1200B

This manual is applicable to units bearing serial numbers above 5900 and is the same as the original manual except for the following.

Throughout the original manual, replace "A", "B", "Channel A", and "Channel B" with "L", "R", "L Channel" and "R Channel", respectively. Also, throughout the original manual, replace "Model 1200" with "Model 1200B",

Page 1 — Column 2, 3rd paragraph — Replace last sentence with: "This switch applies L, R, STEREO, STEREO REVERSE, or L+R signals to the BALANCE CONTROL through the GAIN SWITCH which selects HIGH or LOW overall preamplifier gain."

Page 4 — Column 1, 2nd paragraph — Replace entire paragraph with: "With the TONE CONTROL switch set to IN, the output of the tone amplifier is applied to the PREAMP OUT jacks."

Page 4 — Column 2, 2nd paragraph — Replace entire paragraph with: "With the TONE CONTROL switch set to OUT, the output of the X10 amplifier bypasses the tone amplifier and is applied directly to the PREAMP OUT jacks."

Pages 6 — Replace Figure 5 (Amplifier Simplified Schematic) and 7 with Figure 5 contained herein.

Page 8 — Replace entire circuit description section entitled "Amplifier" with circuit description contained herein.

Page 9 — Replace entire circuit description section entitled "Rectifier-Relay Board" with circuit description section entitled "Relay Board and Main Power Supply" contained herein.

Page 9 — Replace Figure 7 (Rectifier/Relay Board Simplified Schematic) with Figure 7 (Relay Board Simplified Schematic) contained herein.

Page 11 — TECHNICAL SPECIFICATIONS — For "Input Sensitivity and Impedance, Phono" replace "1.35mV, 47K ohms" with "1.35mV @ 1KHz, 47K ohms".

Page 11 — TECHNICAL SPECIFICATIONS — For "Input Sensitivity and Impedance, High Level" replace "135mV, 100K" with "135mV @ 1KHz, 25K ohms".

In "PERFORMANCE VERIFICATION TEST PROCEDURE", replace as indicated:

Page 13 — In paragraph C (Bias Adjustment Tests), sub-paragraph 4 — replace "10 watts" with "7 watts".

Page 14 — In paragraph C (Bias Adjustment Tests), sub-paragraph 5 — replace "10 watts" with "7 watts".

Page 14 — In paragraph E (Total Hum and Noise Test), sub-paragraph 4 — replace "36 millivolts" with "25 millivolts".

Page 14 — In paragraph G (Relay Operation), sub-paragraph 1 — replace "two minutes" with "thirty seconds".

Page 14 — In paragraph G (Relay Operation), sub-paragraph 4 — replace entire sub-paragraph with "Set audio oscillator for 5Hz. Switch load off. Slowly in-

crease output of oscillator until relay de-energizes. Distortion analyzer should indicate between 15 and 28 volts just prior to relay cutoff".

Page 14 — In paragraph H (Harmonic Distortion Test), sub-paragraph 1 — add "Set load to 8 ohms".

Page 17 — Replace Figure 10. (AC Power Control Box Simplified Schematic) with Figure 10. contained herein.

Page 17 — Replace Figure 11. (Amplifier Output Load Box Simplified Schematic) with Figure 11. contained herein.

In "TROUBLE ANALYSIS", replace as indicated:

Page 18 — In SYMPTOM 1. — Replace "(100 watts or more)" with "(80 watts or more)".

Page 18 — In SYMPTOM 1. PROCEDURE a. — Replace ". . . . CR701 through CR704" with ". . . . CR1 through CR4".

Page 18 — In SYMPTOM 1. PROCEDURE b. — Replace "Check for open control R526, 215-1005-1 bias assembly" with "Check for open bias circuit components; Q801, Q521, C513".

Page 18 — In SYMPTOM 2. PROCEDURE a. — Replace ". . . . 215-1005-1 bias assembly" with ". . . . bias circuit components; Q801, Q521, C513".

Page 18 — In SYMPTOM 2. PROCEDURE b. — Replace ". . . . CR701 through CR704" with ". . . . CR1 through CR4".

Page 18 — Replace SYMPTOM 3 with "Transient DC voltages at loudspeaker terminals before time delay circuit is deactivated".

Page 18 — In SYMPTOM 3. Add PROCEDURE b. — "Check for non-opening relay contacts".

Page 18 — In SYMPTOM 4. Add PROCEDURES b. through d. — "b. Check transistors Q503, Q504, Q507, Q508, Q510, Q511, Q516, and Q517". "c. Check for open DC Balance Control, R526". "d. Check capacitors C502, C503, and C504".

Page 18 — In SYMPTOM 5. Add PROCEDURE c. — "Check capacitors C502, C503, and C504".

Page 19 — In SYMPTOM 6. Add PROCEDURES b. and c. — "b. Check C4, C5, and T1 for leakage to chassis. Check C8 and C527 for short". "c. Check Preamp to Amp molded jumper plugs for open ground circuit. Check internal shielded wires for broken insulation allowing shields to short to chassis."

Page 19 — In SYMPTOM 7. PROCEDURE a. — Replace "Check for defective C506, C509, C516, and C505." with "Check for defective C505, C506, C508, C509, C510, C512, C516, C518, C519, C520, C524, C525, and C526". Add PROCEDURE b. — "Check for defective R511, R519, and R539".

Page 19 — In SYMPTOM 8. PROCEDURE b. — Replace "Check for transistors Q802 through Q805." with "Check transistors Q505, Q506, Q516, Q517, Q802 through Q805." Add PROCEDURE c — "Check for open CR1 through CR4."

Page 19 — In SYMPTOM 9. — Replace PROCEDURE b. with "Check output for proper clipping into 4 ohm load with 25.5 volts AC output (positive and negative levels must not vary more than 1 volt at 2 KHz)."

Page 19 — Add SYMPTOM 10. — "No Output". and add PROCEDURE a. — "Check R529, Q510, Q511, Q802 through Q805."

Pages 20 — PARTS LIST — Parts list contained herein identifies all parts which differ from those used in units prior to serial number 3501.

Pages 26 — Replace Figure 13. (Interconnect Board — A1 and 27 Component Assembly Diagram) with Figure 13. contained herein.

Page 28 — Replace Figure 14. (Phono Amplifier Board — A2 Component Assembly Diagram) with Figure 14. contained herein.

Page 31 — Replace Figure 17. (Power Amplifier Board — A5/A6 Component Assembly Diagram) with Figure 17. contained herein.

Page 32 — Replace Figure 18. (Power Supply Board — A7 Component Assembly Diagram) with Figure 18. contained herein.

Page 33 — Replace Figure 19. (Rectifier/Relay Board — A8 Component Assembly Diagram) with Figure 19. (Relay Board — A8 Component Assembly Diagram) contained herein.

Pages 34 — Replace Figure 20. (Model 1200 Schematic, A) and 35 with Figure 20. (Model 1200B Schematic, A) contained herein.

Pages 36 — Replace Figure 21. (Model 1200 Schematic, B) and 37 with Figure 21. (Model 1200B Schematic, B) contained herein.

CIRCUIT DESCRIPTION

AMPLIFIER

The input of the power amplifier, Figure 5, is an RF filter comprised of R550 and C501, followed by transistors Q518 and Q519 which are coupled together as a conjugate paired amplifier with 100% feedback. The output of the conjugate pair is coupled through C502 and R506 to the differential amplifier, Q501-Q502, which drives a high gain inverter, Q503. Q504 is the current source for the inverter, and Q520 serves as a current source for the differential amplifier to enhance its common mode signal rejection. The inverter is coupled to complementary pre-drivers, Q507-Q508. The output of the pre-drivers is applied to the respective drivers, Q510-Q511, which feed their respective power transistors, Q802-Q804 and Q803-Q805.

Open loop phase and gain stabilization is provided by a Miller capacitor, C518, connected between the collector and base of the inverter (Q503). Further open loop stabilization is provided by Miller feedback at driver Q510 by C525 and R561, and at driver Q511 by C524 and R560.

Output current regulation is accomplished through a current-sensing network. Excessive current levels are detected by resistors R531 and R532. Voltages developed across these resistors are applied to current sensors Q516 and Q517. When excessive current levels are detected, Q516 and Q517 develop peak-limiting signals which are applied to Q505 and Q506, respectively. These transistors disable the pre-drivers on excessive output current peaks, thus limiting peak output current to the level determined by the adjustment of R541 and R542, respectively.

Feedback for the amplifier is developed at the junction of R531 and R532, and is applied across two loops. The driver power output loop is across R520 and C509. Feedback applied across R519 and C508 completes the loop for the entire power amplifier.

Idling current for the power transistors is controlled by transistors Q801 and Q521, and is adjusted by R526. Q521 is employed as a V_{be} multiplier with the collector current of Q801 determining the multiplication factor. The multiplied V_{be} voltage of Q521 appears across its collector and emitter. From there, it is applied as a biasing source to the drivers which are dc coupled to the power transistors. Transistor Q801 is mounted directly to the power transistor heatsink to assure close thermal tracking.

PARTS LIST

Reference Designation	Description and/or Remarks	Marantz Part Number	Reference Designation	Description and/or Remarks	Marantz Part Number
A1	Interconnection Board Component Assembly	200-1037-100	Q301	Transistor, NPN	462-1038-210
C101	Cap., 520pf, $\pm 10\%$, 100V	385-1069-000	Q302	Transistor, NPN	462-1038-210
C102	Cap., .15uf, $\pm 20\%$, 250V	386-1022-000	Q304	Transistor, NPN	462-1038-210
C103	Cap., 520pf, $\pm 10\%$, 100V	385-1069-000	Q305	Transistor, NPN	462-1038-210
C104	Cap., .15uf, $\pm 20\%$, 250V	386-1022-000	A5, A6	Heatsink Assembly	215-1012-200
R101	Res., C/F, 1K, $\pm 5\%$, 1/4W	434-4102-000		Amplifier Board Component Assembly	200-1071-200
R102	Res., C/F, 1K, $\pm 5\%$, 1/4W	434-4102-000	C502	Cap., Elect. 10uf, 20V	381-1068-000
R103	Res., Variable, Tandem, 25K	420-1023-000	C503	Cap., Elect., 10uf, 20V	381-1068-000
R104	Res., Variable, Tandem, 50K	420-1048-000	C504	Cap., Elect., 10uf, 20V	381-1068-000
R105	Res., C/F, 12K, $\pm 5\%$, 1/4W	434-5122-000	C505	Cap., 36pf, $\pm 5\%$, 100V	385-1064-000
R106	Res., C/F, 2.7K, $\pm 5\%$, 1/2W	433-4272-000	C506	(not used)	
R107	Res., C/F, 12K, $\pm 5\%$, 1/4W	434-5122-000	C508	Cap., 47pf, $\pm 10\%$, 100V	385-1040-000
R108	Res., C/F, 2.7K, $\pm 5\%$, 1/2W	433-4272-000	C512	Cap., 1000pf, $\pm 10\%$, 100V	385-1068-000
R113	Res., C/F, 33K, $\pm 5\%$, 1/4W	434-5332-000	C518	Cap., 5pf, $\pm 10\%$, 100V	385-1049-000
R114	Res., C/F, 33K, $\pm 5\%$, 1/4W	434-5332-000	C519	Cap., 0.1uf, $\pm 10\%$, 250V	386-1000-000
S101	Switch, Mode	453-1035-000	C520	Cap., 6800pf, $\pm 10\%$, 400V	386-1026-000
S102	Switch, Tone	453-1036-000	C522	Cap., 47pf, $\pm 10\%$, 100V	385-1040-000
S103	Switch, Lo Filter	453-1037-000	C523	Cap., 27pf, $\pm 10\%$, 100V	385-1036-000
S104	Switch, Hi Filter	453-1037-000	C524	Cap., 270pf, $\pm 10\%$, 300V	385-1090-000
	Connector Block, 16 Pin	360-1019-000	C525	Cap., 270pf, $\pm 10\%$, 300V	385-1090-000
	Connector Block, 13 Pin	360-1020-000	C526	Cap., 0.1uf, $\pm 10\%$, 250V	386-1000-000
	Connector Block, 12 Pin	360-1021-000	C527	Cap., Elect., 100uf, 3V	381-1089-000
	Insulator, Light Shield	127-1059-000	L501	Toroid	147-1009-000
A2	Phono Amplifier Board Component Assembly	200-1033-100	R501	Res., C/F, 4.7K, $\pm 5\%$, 1/4W	434-4472-000
C203	Cap., 1.0uf, $\pm 10\%$, 250V	386-1034-000	R502	Res., Variable, 2K, 2W	420-1045-000
C211	Cap., 1.0uf, $\pm 10\%$, 250V	386-1034-000	R503	Res., C/F, 4.7K, $\pm 5\%$, 1/4W	434-4472-000
C215	Cap., 1.0uf, $\pm 10\%$, 250V	386-1034-000	R508	Res., C/F, 39K, $\pm 5\%$, 1/4W	434-5392-000
C224	Cap., 1.0uf, $\pm 10\%$, 250V	386-1034-000	R509	Res., C/F, 4.7K, $\pm 5\%$, 1/4W	434-4472-000
R214	Res., Variable, 25K, 1/4W	420-1024-000	R511	Res., C/F, 1.8K, $\pm 5\%$, 1/4W	434-4182-000
R222	Res., C/F, 2.2M, $\pm 10\%$, 1/4W	434-7223-000	R512	Res., C/F, 7.5K, $\pm 5\%$, 1/4W	434-4752-000
R235	Res., Variable, 25K, 1/4W	420-1024-000	R515	Res., C/F, 27 ohm, $\pm 5\%$, 1/4W	434-2272-000
Q201	Transistor, NPN	462-1038-110	R517	Res., M/F, 1.3K, $\pm 5\%$, 3W	439-1022-000
Q202	Transistor, NPN	462-1038-110	R518	Res., M/F, 1.3K, $\pm 5\%$, 3W	439-1022-000
Q205	Transistor, NPN	462-1038-110	R522	Res., C/F, 560 ohm, $\pm 5\%$, 1/4W	434-3562-000
Q206	Transistor, NPN	462-1038-110	R523	Res., C/F, 560 ohm, $\pm 5\%$, 1/4W	434-3562-000
A3	X10 Board Component Assembly	200-1022-100	R524	Res., C/F, 24K, $\pm 5\%$, 1/4W	434-5242-000
C402	Cap., 1.0uf, $\pm 10\%$, 100V	386-1018-000	R525	Res., C/F, 24K, $\pm 5\%$, 1/4W	434-5242-000
C403	Cap., Elect. 1.0uf, 35V	381-1055-000	R526	Res., Variable, 100 ohm, 2W	420-1044-000
C407	Cap., Elect. 1.0uf, 35V	381-1055-000	R527	Res., C/F, 47 ohm, $\pm 5\%$, 1/4W	434-2472-000
C413	Cap., 1.0uf, $\pm 10\%$, 100V	386-1018-000	R528	Res., C/F, 47 ohm, $\pm 5\%$, 1/4W	434-2472-000
C414	Cap., Elect. 1.0uf, 35V	381-1055-000	R529	Res., M/F, 39 ohm, $\pm 5\%$, 1W	439-1023-000
C417	Cap., Elect. 1.0uf, 35V	381-1055-000	R530	Res., M/F, 39 ohm, $\pm 5\%$, 1W	439-1023-000
Q401	Transistor, NPN	462-1038-210	R539	Res., M/F, 27 ohm, $\pm 5\%$, 2W	439-1021-000
Q402	Transistor, NPN	462-1038-210	R540	Res., C/F, 2.2K, $\pm 5\%$, 1/4W	434-4222-000
Q404	Transistor, NPN	462-1038-210	R541	Res., Variable, 2.5K, 1/4W	420-1046-000
Q405	Transistor, NPN	462-1038-210	R542	Res., Variable, 2.5K, 1/4W	420-1046-000
A4	Tone Amplifier Board Component Assembly	200-1023-000	R543	Res., C/F, 2.2K, $\pm 5\%$, 1/4W	434-4222-000
C301	Cap., 1.0uf, $\pm 10\%$, 100V	386-1018-000	R544	Res., C/F, 1K, $\pm 5\%$, 1/4W	434-4102-000
C309	Cap., 1.0uf, $\pm 10\%$, 250V	386-1034-000	R545	Res., C/F, 1K, $\pm 5\%$, 1/4W	434-4102-000
C311	Cap., 1.0uf, $\pm 10\%$, 100V	386-1018-000	R547	Res., C/F, 20K, $\pm 5\%$, 1/4W	434-5202-000
C318	Cap., 1.0uf, $\pm 10\%$, 250V	386-1034-000	R548	Res., C/F, 270 ohm, $\pm 5\%$, 1/4W	434-3272-000
R307	(not used)		R549	Res., C/F, 5.6K, $\pm 5\%$, 1/4W	434-4562-000
R312	Res., C/F, 56 ohm, $\pm 5\%$, 1/4W	434-2562-000	R552	Res., C/C, 5.6 ohm, $\pm 5\%$, 1W	423-1562-000
R322	(not used)		R553	Res., C/C, 5.6 ohm, $\pm 5\%$, 1W	423-1562-000
			R554	Res., C/F, 56K, $\pm 5\%$, 1/4W	434-5562-000
			R555	Res., C/F, 22K, $\pm 5\%$, 1/4W	434-5222-000
			R556	Res., C/F, 360 ohm, $\pm 5\%$, 1/4W	434-3362-000
			R557	Res., C/F, 10 ohm, $\pm 5\%$, 1/4W	434-2102-000
			R558	Res., C/F, 560 ohm, $\pm 5\%$, 1/4W	434-3562-000
			R559	Res., C/F, 470 ohm, $\pm 5\%$, 1/4W	434-3472-000
			R560	Res., C/F, 10 ohm, $\pm 5\%$, 1/4W	434-2102-000
			R561	Res., C/F, 10 ohm, $\pm 5\%$, 1/4W	434-2102-000
			R562	Res., C/F, 10 ohm, $\pm 5\%$, 1/4W	434-2102-000

Reference Designation	Description and/or Remarks	Marantz Part Number
Q501	Transistor, NPN	462-1066-010
Q502	Transistor, NPN	462-1066-010
Q503	Transistor, PNP	461-1054-010
Q507	Transistor, PNP	* 461-1056-000
Q508	Transistor, NPN	* 462-1053-000
Q510	Transistor, NPN	* 462-1054-000
Q511	Transistor, PNP	* 461-1046-000
Q516	Transistor, NPN	462-1058-010
Q517	Transistor, PNP	461-1050-010
Q518	Transistor, PNP	461-1055-010
Q519	Transistor, NPN	462-1038-210
Q520	Transistor, NPN	462-1042-000
Q521	Transistor, PNP	461-1055-010
	Thermal Retainer (TO-92 Pr)	562-1007-000
	Heat Dissipator (TO-5)	562-1000-000
	Transistor Insulator (TO-5)	372-1000-000
	Transistor Insulator (TO-66)	371-1007-000
	Nylon Washer	676-1006-000
	Nylon Shoulder Washer	676-1008-000
	Toroid Retainer	570-1003-000
C801		(not used)
CR801		(not used)
Q801	Transistor, NPN (includes mtg washer and insulator)	462-1067-010
	Heat Sensor Assy	(not used)
	Wire & Socket Assy	157-1011-100
Q802	Transistor, PNP	* 461-1031-010
Q803	Transistor, NPN	* 462-1036-010
Q804	Transistor, PNP	* 461-1031-010
Q805	Transistor, NPN	* 462-1036-010
A7	Power Supply Board Component Assembly	200-1025-500
Q601	Transistor, NPN	462-1055-000
Q602	Transistor, PNP	461-1048-000
A8	Relay Board Component Assembly	200-1075-100
CR701		(not used)
CR702		(not used)
CR703		(not used)
CR704		(not used)
R709		(not used)
R710		(not used)
R711	Res., W/W, 300 ohm, $\pm 10\%$ 5W	428-3303-000
	Chassis Assembly	
C8	Cap., Elect., 100uf, 3V	381-1090-000
CR1	Diode, Rectifier	460-1014-000
CR2	Diode, Rectifier	460-1014-000
CR3	Diode, Rectifier	460-1014-000
CR4	Diode, Rectifier	460-1014-000
DS1	Lamp, Pilot	482-1001-000
J4	Phone Jack, Dubbing In	360-1004-000
J5	Phone Jack, Dubbing Out	360-1005-000
J6	Phone Jack, Stereophones	360-1005-000
J7	Tape Recorder Jack, DIN	360-1016-000
J8, J19	Phone Jack, Mic	360-1017-000

Reference Designation	Description and/or Remarks	Marantz Part Number
R1	Res., C/F, 130K, $\pm 5\%$, 1/2W	433-6132-000
R2	Res., C/F, 130K, $\pm 5\%$, 1/2W	433-6132-000
R3	Res., C/F, 130K, $\pm 5\%$, 1/2W	433-6132-000
R4	Res., C/F, 130K, $\pm 5\%$, 1/2W	433-6132-000
R5		(not used)
R6		(not used)
R7		(not used)
R8		(not used)
R9	Res., C/F, 27 ohm, $\pm 5\%$, 1/2W	433-2272-000
R10		(not used)
R13	Res., W/W, 2.2K, $\pm 5\%$, 2W	436-4222-000
R14	Res., W/W, 2.2K, $\pm 5\%$, 2W	436-4222-000
S1	Switch, Selector	453-1018-000
S3	Switch, Slide	452-1019-000
S4	Switch, Power	452-1016-000
S5	Switch, Speaker	453-1034-000
T1	Transformer, Power	440-1011-150
	Miscellaneous Parts	
	Rear Panel Circuit Board	200-1036-100
	Diode Mounting Board Assy	201-1005-100
	Knob, Large	174-1001-000
	Knob, Medium	174-1002-000
	Knob, P/B Switch	174-1004-000
	Panel, Front Dress	134-1032-200
	Cover, Top	136-1003-000
	Cover, Transistor	136-1017-000
	Lens, Light	170-1002-000
	Connector, Molded	360-1027-000
	Shield, Lamp	483-1000-000
	Binding Post, Chassis Grd.	359-1004-000
	Jack, Center Channel	360-1030-000
	Insulator, Ctr Chan Jack	370-1005-000

*For beta range matching requirements, see transistor specification chart on unit schematic (Figure 21).

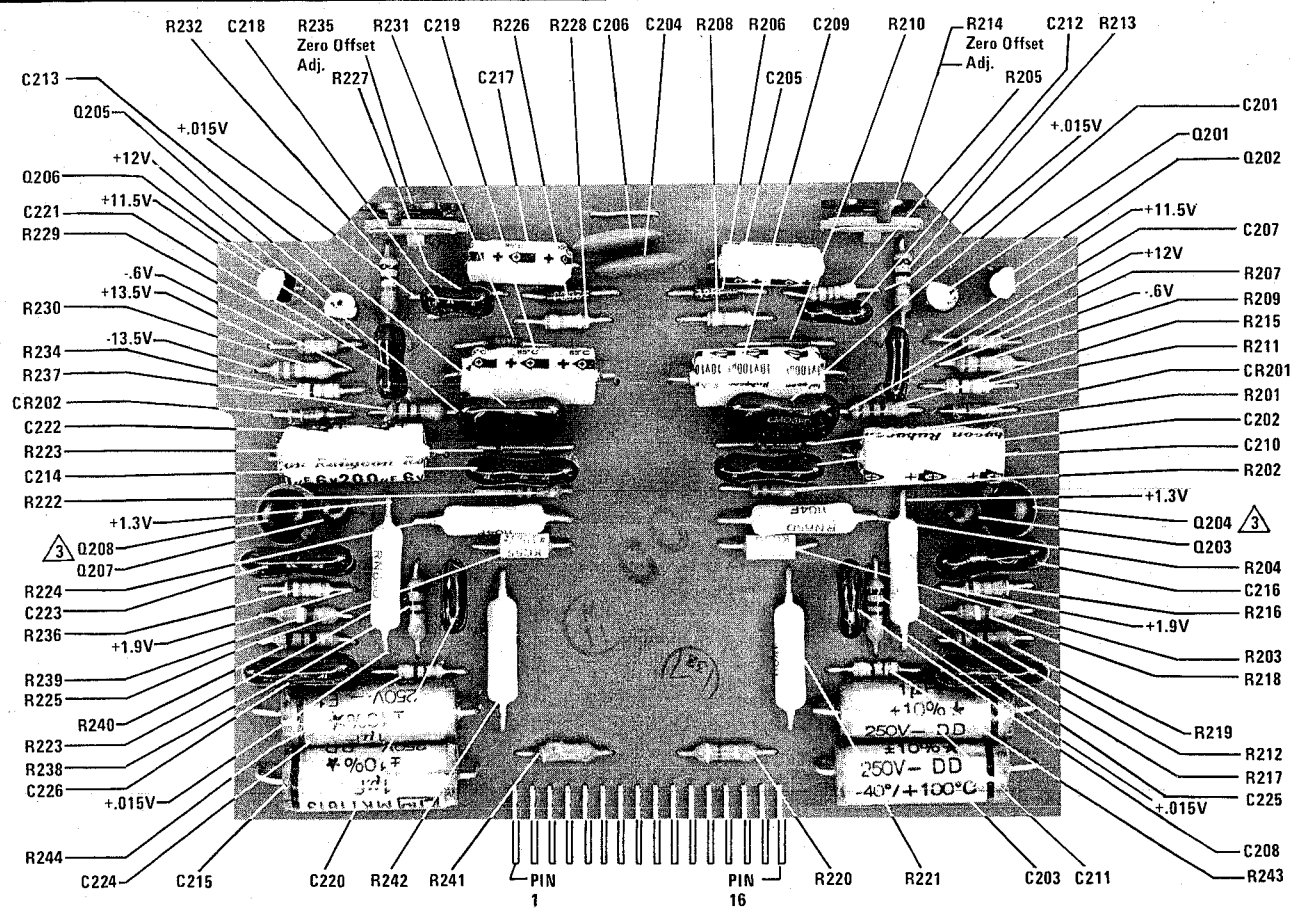

COMPONENT SIDE

- Notes:
1. Voltages are d-c volts to ground, measured on a typical unit.
 2. Configuration shown is applicable to circuit boards fabricated from A/W 115-1033, Rev N/C.
 3. P/N 372-1000-000 Insulator to be installed under Q204 and Q208.

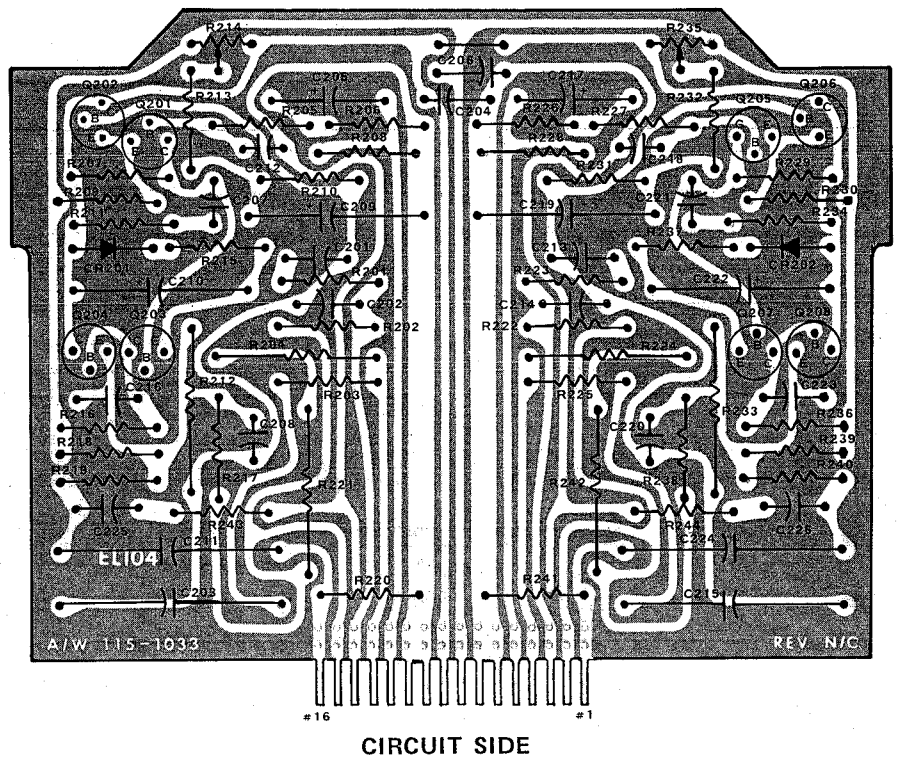

CIRCUIT SIDE

Figure 14. Phono Amplifier Board – A2 Component Assembly Diagram