

MODEL LDM - 815

TR DIP METER

INSTRUCTION MANUAL

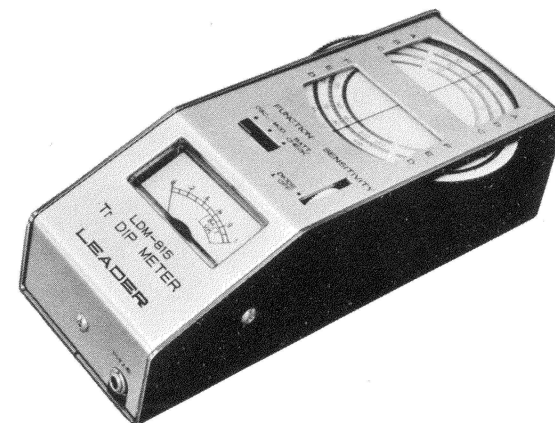

LEADER ELECTRONICS CORP.

2-6-33 TSUNASHIMA-HIGASHI, KOHOKU-KU,
YOKOHAMA, JAPAN.

PHONE: (045) 541-2121 TELEX: J47780 JPLEADER

LEADER INSTRUMENTS CORP.

380 OSER AVENUE, HAUPPAUGE, N.Y. 11788 U.S.A.
PHONE: (516) 231-6900

TELEX: 510-227-9669 LEADER HAUP

LEADER ELECTRONICS CORP.

1. GENERAL

LDM-815 is a transistorized dip meter for rapidly checking circuits and components in receivers, transmitters, antennas, etc., in the 1.5 to 250MHz range. It is designed for many applications in Amateur Radio stations and service shops.

2. SPECIFICATIONS

Frequency Range 1.5 to 250MHz with six plugin coils:

Band	Range	Color Code
A	1.5 ~ 4MHz	Red
B	3.3 ~ 8MHz	Yellow Red
C	6.8 ~ 18MHz	Yellow
D	18 ~ 47MHz	Yellow Green
E	45 ~ 110MHz	Blue
F	100 ~ 250MHz	Purple

Modulation : Approx. 2kHz: sine wave
 Crystal Oscillator : 1-15MHz, crystal in FT-243 holder
 Power Supply : 9 volt battery: 006p, NEDA 1604, Eveready 216, Burgess 2U6, or equivalent

Current Consumption : 2mA, maximum

Semiconductor

Complement : 2 transistors and 1 diode

Size and Weight : 175 (H) × 65 (W) × 50 (D) mm;
 $6 \frac{7}{8}$ '' (H) × $2 \frac{9}{16}$ '' (W) × 2'' (D)
 approx. 0.5 kg
 1.1 lbs.

Accessories, Supplied : Earphone plug 1ea.

3. PANEL CONTROLS

- Frequency dial : Six frequency scales calibrate according to bands and color of the coil in use.
- Meter : For indicating resonance and for battery check; sensitivity is $100\mu\text{A}$ at full scale.
- Function switch : Three positions
- OSC : For use as a dip meter or absorption wavemeter.
 - MOD : Applies 2kHz AM to the carrier output.
 - BATT : For checking condition of CHECK internal battery.
- SENSITIVITY : Adjusts the output level of the oscillator; at OFF, the power supply is cut off and the instrument can be used as an absorption wavemeter.
- Earphone jack : For monitoring AM signals with a crystal earphone (not supplied).

4. CIRCUIT DESCRIPTION

The RF oscillator is a Colpitts type using a silicon transistor. The RF voltage is rectified with a diode and the current is indicated on the $100\mu\text{A}$ DC meter. When the dip meter frequency is in resonance with the external circuit, the meter pointer will dip. The strength of the oscillator output is controlled with the SENSITIVITY adjuster.

When required, amplitude modulation can be applied to the RF oscillator output. A twin-T type circuit is used for the 2kHz source.

In the absorption wavemeter function, the RF oscillator power is cut off and the tuned and diode-meter circuits are used.

5. PRECAUTIONS IN OPERATION

1. During standby periods or when the dip meter is not in use, set SENSITIVITY adjuster at OFF (clicked). This will prolong battery life.
2. Handle the coils carefully when inserting or removing same from the socket.
3. During measurements, the coil should be loosely coupled to the test circuit. The coupling must be as loose as possible to obtain proper meter indication. Close coupling will introduce errors in measurement.
IMPORTANT! When checking transmitting equipment, close coupling will damage the diode detector by overload.
4. Disconnect the battery from the internal circuit when the dip meter is not in use for long periods.

6. OPERATION

1. Battery Check and Replacement

1. Set FUNCTION at BATT CHECK.
2. Advance SENSITIVITY to power at on (clicked condition). The meter pointer should swing to the BATT OK portion on the scale. If not, renew the battery.

NOTE: To install or replace the battery, remove the covers as follows:

Remove the two screws each at the right and left sides of the instrument; take off the covers. Loosen

the battery clamp screw at center of the chassis and take out the battery. Remove the snap terminals from the battery. To install; reverse steps. Tighten the clamp screw and put on the side covers.

3. After this check, set SENSITIVITY at OFF (clicked).

2 Use as a Dip Meter

1. Plug the coil for the band in use in the socket.
2. Set FUNCTION at OSC.
3. Advance SENSITIVITY past the click point so that the meter pointer swings to about 0.8.

NOTE: When the "F" coil is used, there will be some variation in the meter deflection as the frequency dial is rotated. This effect will be present when the coil is not coupled to the test circuit. Care must be taken during use not to confuse this condition with the actual dip caused by the test circuit.

4. Couple the coil loosely to the test circuit and rotate the frequency dial in small steps until a dip is observed on the meter. (When there are two dips close together, place the coil farther from the test circuit.)
5. Adjust the frequency dial until the maximum dip is obtained.
6. Note the frequency on the frequency dial.
7. Set SENSITIVITY at OFF (clicked) after the tests.
8. Examples of typical coupling methods are shown in Fig. 1.

NOTE: It is important that the power, if applied, to the test circuit is turned off.

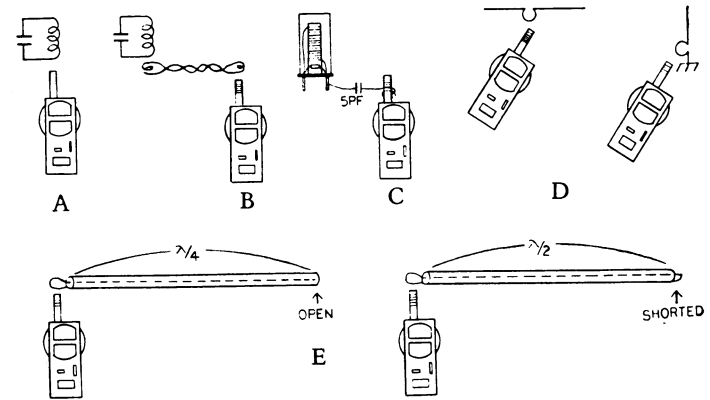

Fig. 1 Dip meter coupling methods.

A and B : Direct or link types.

C : For shielded circuits; the coupling capacitor should be as small as possible.

D : Determination of resonant frequency of an antenna; use a 1-turn coil in the antenna. (For vertically grounded antennas, do not forget to make the ground connection.)

E : **Determination of electrical length of quarter-wave and half-wave coaxial feeders.**

3 Use as an Absorption Wavemeter

1. Plug the coil for the band in use in the socket.
2. Set SENSITIVITY at OFF (clicked).
3. Set FUNCTION at OSC.
4. When the coil is coupled to the coil in an oscillator, or RF tank coil in a transmitter, the meter pointer will swing upward when tuned to resonance. The amount of the swing depends on the strength of the oscillations and/or coupling distance.

NOTE: In checking transmitters, take care that the energy picked up will not overload the instrument, otherwise the diode detector will be damaged. Further, do not touch any of the high voltage points within the transmitter; safety is important.

5. Read the frequency.
6. Typical applications are shown in Fig. 2.

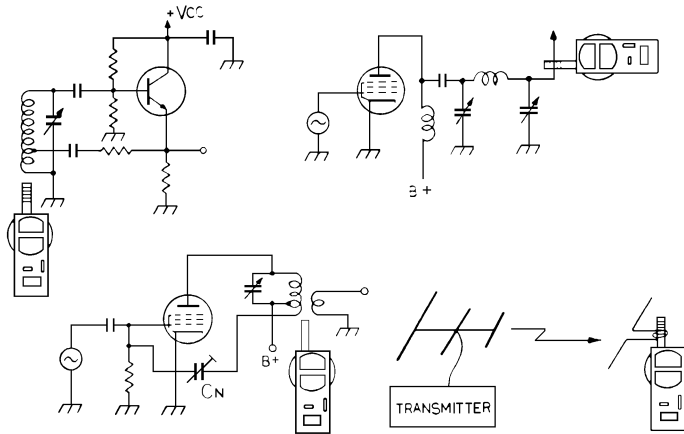

Fig. 2 Absorption wavemeter applications.

- A : Measurement of oscillator frequency.
- B : Measurement of frequency at the transmitter output. To check for harmonics or parasitics, slowly rotate the frequency dial for the indications; change the coils as necessary. The meter deflection will indicate the relative strength of these signals.
- C : Neutralizing adjustments can be made by first cutting off DC supply to the plate and screen grid circuits. The

tank circuit is then tuned for maximum indication. Next the neutralizing capacitor, CN, is adjusted for minimum indication.

D : Use as a field strength meter is shown. A short antenna is coupled to the coil for signal pickup. When the wavemeter is tuned to the operating frequency and at different positions around the antenna, the relative field strength will be indicated on the meter.

4 Short Wave Receiver Testing

In this application, the dip meter is used as a simple test oscillator, with or without amplitude modulation.

The test frequency is set with the suitable coil and frequency dial. The dip meter is placed near the receiver; the "input signal strength" can be varied with the distance between the dip meter and the receiver.

For operation, set SENSITIVITY for RF output.

Communications receivers with beat oscillators can be tested by setting FUNCTION at OSC for the CW signal.

When an AM signal is required, set FUNCTION at MOD. A tone of approximately 2kHz will be heard in the loudspeaker.

Adjustments, as required, can be made, with the respective signals, in the receiver circuits.

5 Monitoring Phone Signals

The wavemeter application, see Sect. 5.3, can be used for monitoring AM phone signals.

A crystal earphone is connected to the earphone plug and the plug is inserted in the PHONE jack.

Tune to the RF test frequency using the proper coil.

For "remote" indication of the modulated output, a 100 μ A DC meter can be connected to the earphone plug; the inner

contact is the + side.

6 Use as a Crystal Oscillator

In place of the coil, a quartz crystal, 1 - 15MHz, in the FT-243 holder, inserted in the socket will produce output at the crystal frequency.

Set FUNCTION at OSC and SENSITIVITY as required for the output. The frequency dial is rotated until the most stable condition is obtained.

Set the dip meter near the receiver for signal pickup. For modulated output, set FUNCTION at MOD.

7 Audio Signal Output

Set up the instrument for dip meter operation, see Sect. 2, in the socket (However, the RF is not used.)

Set FUNCTION at MOD.

Audio output at approximately 2kHz is available at the PHONE jack. The plug connections are as follows:

Inner contact for the "hot" side and the sleeve for ground.

This signal can be used for checking audio circuits.

8 Inductance and Capacitance Measurements

Unknown inductances and capacitances can be determined with use of the dip meter, see Sect. 5-2 and "A" in Fig. 1.

A : Inductance measurement:

A capacitor of known value is required. This capacitor is connected in parallel with the unknown coil and the resonant frequency is noted.

The inductance is calculated from the following:

$$L = \frac{25.330}{C_{\text{pF}} (f_{\text{MHz}})^2} \mu\text{H}$$

With use of a standard 100pF capacitor, the measureable inductance range is from 113 μH to 0.004 μH with use of the frequency range in the dip meter.

B : Capacitance measurement:

An inductance of known value is connected in parallel with the unknown capacitor, and the resonant frequency is noted.

The capacitance is calculated from the following:

$$C = \frac{25.330}{L_{\mu\text{H}} (f_{\text{MHz}})^2} \text{pF}$$

For the "standard", the coils in the dip meter can be used when applicable. The respective inductance values are shown below:

Band	A	B	C	D	E	F
$L_{\mu\text{H}}$	161 μH	39 μH	8.4 μH	1.2 μH	0.22 μH	0.047 μH

PLUG IN COIL

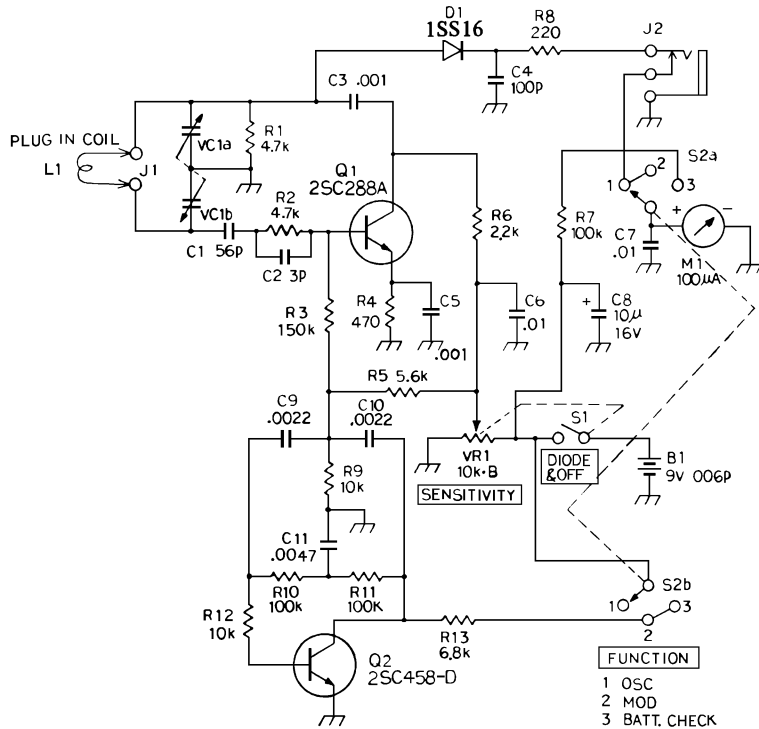
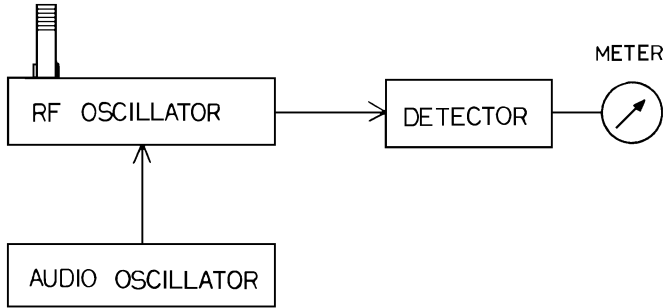

LDM-815 Parts List

Symbol	Description				Leader Parts No.
RESISTORS					
R1	Carbon film	0.25W	4.7KΩ	± 5%	RD¼PNY 4.7KΩJ
R2	Carbon film	0.25W	4.7KΩ	± 5%	RD¼PNY 4.7KΩJ
R3	Carbon film	0.25W	150KΩ	± 5%	RD¼PNY 150KΩJ
R4	Carbon film	0.25W	470Ω	± 5%	RD¼PNY 470ΩJ
R5	Carbon film	0.25W	5.6KΩ	± 5%	RD¼PNY 5.6KΩJ
R6	Carbon film	0.25W	2.2KΩ	± 5%	RD¼PNY 2.2KΩJ
R7	Carbon film	0.25W	100KΩ	± 5%	RD¼PNY 100KΩJ
R8	Carbon film	0.25W	220Ω	± 5%	RD¼PNY 220ΩJ
R9	Carbon film	0.25W	10KΩ	± 5%	RD¼PNY 10KΩJ
R10	Carbon film	0.25W	100KΩ	± 5%	RD¼PNY 100KΩJ
R11	Carbon film	0.25W	100KΩ	± 5%	RD¼PNY 100KΩJ
R12	Carbon film	0.25W	10KΩ	± 5%	RD¼PNY 10KΩJ
R13	Carbon film	0.25W	6.8KΩ	± 5%	RD¼PNY 6.8KΩJ
VARIABLE RESISTOR					
VR1	Carbon film	0.1W	10KΩ	± 20%	V161A-1S-B10KΩ
CAPACITORS					
C1	Mica film	500WV	56pF	± 10%	FM07ZC 560K5
C2	Mica film	500WV	3pF	± 10%	FM05ZC 030K5
C3	Ceramic	500WV	0.001μF	-10% + 5%	CK61YZ 102PZ500
C4	Mica film	50WV	100pF	± 10%	VFM07ZC 101K
C5	Ceramic	50WV	0.01μF	- 8% + 20%	RD204YM 103Z50
C6	Ceramic	500WV	0.001μF	- 10% + 5%	CK61YZ102PZ500-
C7	Ceramic	50WV	0.01μF	- 10% + 20%	RD204YM 103Z50
C8	Electrolytic	16WV	10μF		CE0 4W1C100
C9	Plastic film	50WV	0.0022μF	± 10%	CQ92M1H 222K
C10	Plastic film	50WV	0.0022μF	± 10%	CQ92M1H 222K
C11	Plastic film	50WV	0.0047μF	± 10%	CQ92M1H 472K
VARIABLE CAPACITOR					
VC1	Air variable cap.		5.75~125.5pF	±1%	C221A112
TRANSISTORS					
Q1	Silicon NPN		2SC288A		2SC288A
Q2	Silicon NPN		2SC458-D		2SC458-D
DIODE					
D1	Silicon point contact		1SS16		1SS16
PLUG-IN COILS					
L1		6 Plug-in coils, band A ~ F			L-393D
SWITCHES					
S1		Gang with VR1			S-2330-15mm
S2		Slide			

Symbol	Description	Leader Pats No.
	PRINTED CIRCUIT BOAD	
		T-572A
	SOCKET AND JACK	
J1	Type FT-243 crystal socket	FT-243
J2	Mini phone jack	SG-8050
	METER	
M1	Plastic meter 100 μ A	KM-48-100 μ A
	BATTERY	
B1	Dry battery 9V	006P
	ACCESARY	
	Mini phone plug	SH-5006