



Read me
FIRST

www.CookWithKenyon.com

KENYON®

Make any day a weekend

1, 2, & 3 BURNER TOUCH CONTROL - NON UL OWNERS MANUAL

Part # 145357
Revised: August 2, 2017

Contents

IMPORTANT SAFETY INSTRUCTIONS	3
Product Specifications	
Three Burner Models.....	5
Two Burner Large Models.....	5
Two Burner Trimline Models.....	6
One Burner Built-In Models.....	6
One Burner Portable Model	7
Cleaning and Care	
Cleaning the Cooktop.....	9
Use Good Quality Cookware	9
Operation	
How the Elements Operate.....	10
Indicator Lights.....	10
Kenyon PUPS™.....	10
<u>Lock Function Cooktops</u>	
Turning On	11
Turning Off	11
Lock Mode	12
Automatic Shut-Off	12
Temperature Setting Guide	12
<u>Non Lock Function Cooktops</u>	
Touch Controls	13
Automatic Shut-Off.....	14
Temperature Setting Guide.....	14
Installation	
Unpacking the Cooktop.....	15
Check Electrical Supply Requirements.....	15
Countertop Preparation.....	17
Installing the Cooktop.....	18
Electrical Connection.....	19
Final Preparations Prior to Use.....	19
Warranty	20

Please read & save these instructions

Thank you for choosing **Kenyon**, the world's leading manufacturer of specialty cooking appliances. By following the instructions in this owners manual, your cooktop will provide you with many years of reliable service.

To ensure our ability to continue serving you, please use this page to record important product information.

For quick reference please keep a record here:

Purchase date

Model number

Serial number

Name plate location

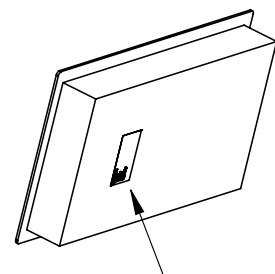

IMPORTANT SAFETY INSTRUCTIONS

**Read this section BEFORE operating the cooktop.
The following information applies to all
KENYON Electric Cooktops.**

**THIS COOKTOP, LIKE ALL APPLIANCES, HAS THE POTENTIAL TO
CREATE SAFETY PROBLEMS THROUGH CARELESS AND
IMPROPER USE. PLEASE OBSERVE ALL OF THE
FOLLOWING SAFETY PRECAUTIONS.**

Proper Installation.

Be sure your appliance is properly installed and grounded by a qualified technician.

Never use your appliance for warming or heating the room.

CAUTION

Do not leave children alone.

Children should never be left alone or unattended in the area where the appliance is in use. They should never be allowed to sit or stand on any part of the appliance. Do not let children play with cooktop. Do not store items of interest to a child in cabinets above the cooktop. Children climbing on the cooktop to reach such items could be seriously injured.

Wear proper clothing/apparel.

Loose fitting or hanging garments should never be worn while using the appliance. Fabric or other flammable materials may contact hot surfaces during operation and may ignite and result in personal injury.

USER SERVICING

Do not repair or replace any part of the appliance. If service ever becomes necessary, this appliance should be serviced by **AUTHORIZED PERSONNEL ONLY** or call **KENYON Customer Care** at (860)664-4906.

Storage in or on Appliance

Flammable materials should not be stored above, under or near surface cooking units.

Keep flammable materials away from cooktop.

Do not store plastic material (such as plastic utensils) in storage areas beneath cooktop.

Plastic items with low melting temperatures should not be stored under/over or near the cooktop.

Do not use water on grease fires.

Smother fire or flame or use dry chemical or foam-type extinguisher.

Special instructions for Model B41573 & B41570 (Unit equipped with GFCI cord & intended for outdoor use)

Outdoor extension cords should be used with outdoor use products and are surface marked with the suffix letter "W" and with a tag stating "Suitable for use with outdoor appliances." When connecting the appliance to such a cord, the connection must be kept dry and off the ground.

IMPORTANT SAFETY INSTRUCTIONS

Use only dry potholders.

Moist or damp potholders on hot surfaces may result in burns from steam. Do not let potholder touch the heating elements on the appliance. Do not use a towel or other bulky cloth in place of a potholder.

Do not cook on broken cooktop.

If cooktop should break, cleaning solutions and spillovers may penetrate the broken cooktop and create a risk of electric shock. Contact an authorized service center or KENYON Customer Care immediately at (860) 664-4906.

Clean cooktop with caution.

If a wet sponge or cloth is used to wipe spills on a hot cooking surface, be careful to avoid steam burns. Some cleaners produce noxious fumes if applied to a hot surface. Read the cleaner label for details prior to using.

Cookware should always be dry.

Do not heat cookware with excess water droplets on the outside of the pan. The droplets may begin to boil and splatter.

DO NOT TOUCH HEATING ELEMENTS

The heating elements on the cooktop may be hot even if they are dark in color. These areas may be hot enough to cause burns. Never touch heating elements until they have had sufficient time to cool. Likewise, never allow clothing or flammable materials to come in contact with heating elements or cooktop surfaces until they have had sufficient time to cool. Other surfaces of the appliance may become hot enough to cause burns.

Use proper pan size.

This appliance is equipped with one or more surface units of different size. Select utensils having flat bottoms large enough to cover the surface unit heating element. The use of undersized utensils will expose a portion of the heating element to direct contact and may result in ignition of clothing. Proper relationship of utensil to burner will also improve efficiency.

Never Leave Surface Units Unattended at High Heat Settings.

Boilover causes smoking and greasy spillovers that may ignite.

Glazed cooking utensils

Only certain types of glass, glass/ceramic, ceramic, earthenware, or other glazed utensils are suitable for rang-tip service without breaking due to sudden change in temperature.

DO NOT USE ALUMINUM FOIL ON THE SURFACE OF THE COOKTOP.

Utensil Handles Should be Turned Inward and Not Extend Over Adjacent Surface Units.

To reduce the risk of burns, ignition of flammable materials, and spillage due to unintentional contact with the utensil, the handle of a utensil should be positioned so that it is turned inward, and does not extend over adjacent surface units.

DO NOT DISCARD THESE INSTRUCTIONS, KEEP THEM WITH THE KENYON COOKTOP FOR FUTURE REFERENCE.

Product Specifications

Three Burner Models

- B40547 (240V)
- B40547PUPS (240V)

BURNER DATA		
VOLTAGE	DIAMETER	OUTPUT IN WATTS
240V AC	Two 6.5" (165mm)	1200 each
	One 8" (200mm)	1800

PRODUCT DIMENSIONS		
WIDTH	DEPTH	HEIGHT
30"	14 1/4"	4 1/8"
762mm	362mm	104.8mm

CUTOUT DIMENSIONS		
WIDTH	DEPTH	RADIUS
29 1/8"	13 3/8"	1/4"
740mm	340mm	6.4mm

Two Burner Large Models

- B41540PUPS (120V)
- B41540LPUPS (120V)
- B41541PUPS (240V)
- B41541LPUPS (240V)

BURNER DATA		
VOLTAGE	DIAMETER	OUTPUT IN WATTS
120V AC	One 6.5" (165mm)	1200
	One 8" (200mm)	1400
240V AC	One 6.5" (165mm)	1200
	One 8" (200mm)	1800

PRODUCT DIMENSIONS		
WIDTH	DEPTH	HEIGHT
23 1/4"	14 1/4"	4 1/8"
590.6mm	362mm	104.8mm

CUTOUT DIMENSIONS		
WIDTH	DEPTH	RADIUS
21 3/4"	12 3/4"	1/4"
552.5mm	323.9mm	6.4mm

Product Specifications

Two Burner

Trimline Models

- **B40575** (120V)
- **B40575L** (120V)
- **B40575PUPS** (120V)
- **B40575LPUPS** (120V)
- **B40579PUPS** (120V)
- **B40581LPUPS** (120V)
- **B40583PUPS** (120V)
- **B40576** (240V)
- **B40576L** (240V)
- **B40576PUPS** (240V)
- **B40576LPUPS** (240V)
- **B40580PUPS** (240V)
- **B40582LPUPS** (240V)
- **B40588PUPS** (240V)

BURNER DATA		
VOLTAGE	DIAMETER	OUTPUT IN WATTS
120V AC	Two 6.5" (165mm)	1200 each
240V AC	Two 6.5" (165mm)	1200 each

PRODUCT DIMENSIONS		
WIDTH	DEPTH	HEIGHT
21"	12"	4 1/8"
533.4mm	304.8mm	104.8mm

CUTOUT DIMENSIONS		
WIDTH	DEPTH	RADIUS
20"	10 3/4"	1/4"
508mm	273mm	6.4mm

One Burner

Built-in Models

- **B40571** (120V)
- **B40571PUPS** (120V)
- **B41573** (120V)
- **B40586PUPS** (120V)
- **B40589PUPS** (120V)
- **B40572** (240V)
- **B40572PUPS** (240V)
- **B41572** (240V)
- **B40587PUPS** (240V)

BURNER DATA		
VOLTAGE	DIAMETER	OUTPUT IN WATTS
120V AC	One 6.5" (165mm)	1200
240V AC	One 6.5" (165mm)	1200

PRODUCT DIMENSIONS		
WIDTH	DEPTH	HEIGHT
12 1/2"	12"	4 1/8"
317.5mm	304.8mm	104.8mm

CUTOUT DIMENSIONS		
WIDTH	DEPTH	RADIUS
11 1/2"	10 3/4"	1/4"
292.1mm	273mm	6.4mm

Product Specifications

One Burner
Portable Model
- B41570 (120V)

BURNER DATA		
VOLTAGE	DIAMETER	OUTPUT IN WATTS
120V AC	One 6.5" (165mm)	1200

PRODUCT DIMENSIONS		
WIDTH	DEPTH	HEIGHT
12 1/2"	12"	5 3/10"
317.5mm	304.8mm	134.6mm

Product Specifications

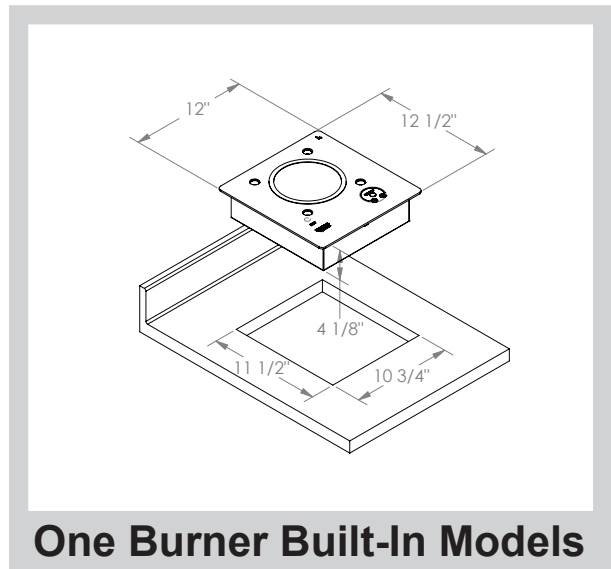
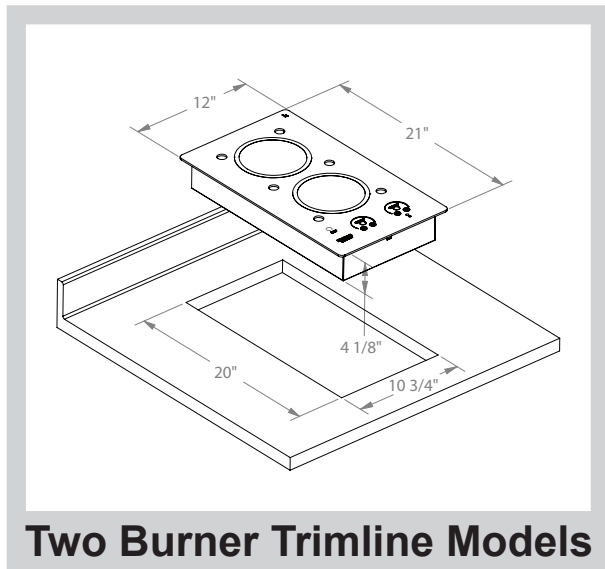
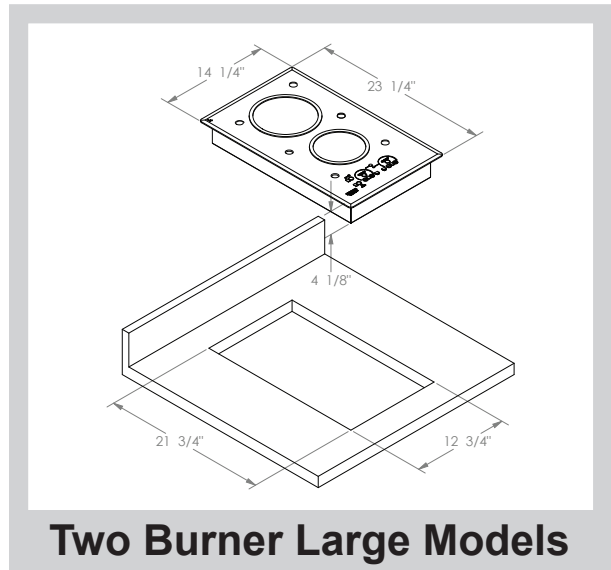
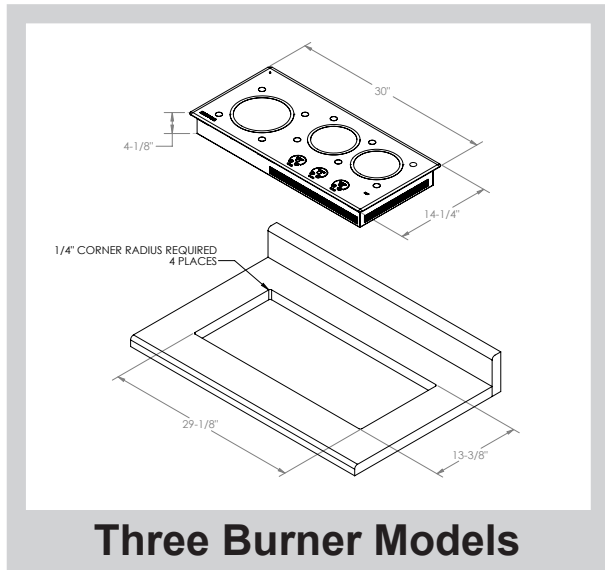

Cleaning and Care

Cleaning the Cooktop

The cooking surface and control areas of your ceramic glass cooktop are identified by permanent patterns in the cooktop. The appliance is easy to maintain and clean. Keep the cooktop in top performance by following these simple guidelines for use and cleaning.

NOTE:

To prevent accidental activation of the touch controls, it is recommended that you enable the **LOCK MODE** feature before cleaning. **This only pertains to cooktops that have a lock function.**

Clean the cooktop before you use it for the first time. A thorough cleaning with a recommended cooktop cleaner (**Cerama Bryte Ceramic Cooktop Cleaner**). A sample is included with your Kenyon cooktop.

Always remove food spills, grease spatters and metal rub-off from cookware. A razor blade scraper or the equivalent works well to remove spillovers.

When the cooktop is cool, clean it with a paper towel or a clean, soft cloth and **Cerama Bryte Ceramic Cooktop Cleaner**. After cleaning, always wipe the cooktop with a clean, damp cloth to avoid cooked-on cleaner residue, then wipe the cooktop dry.

Do not use a dish towel or sponge to wipe off the cooktop. A film may be left by the detergent and may cause discoloration of the cooktop surface.

Avoid abrasive scouring cleaners of any kind. Also avoid using plastic, nylon or metal cleaning pads. They may scratch or melt onto the cooktop.

Avoid chemical cleaners such as chlorine bleach, ammonia, hydrofluoric acid or chemical oven cleaners. They can etch or discolor the surface.

Do not let anything that melts - plastic, aluminum foil, sugar, etc. come into contact with the cooktop surface when it is hot. Should something melt onto the surface, immediately move it to a cool area of the cooktop with a razor blade scraper and then remove it from the cooktop as soon as possible.

Use Good Quality Cookware

Since cookware plays an important role in cooking efficiency and convenience, keep in mind the following information when selecting your cookware.

A cast iron pan, stainless steel pan, aluminum pan or combination steel/stainless steel pan are recommended to prevent damage to the cooktop. ***The use of enamel coated cookware is not recommended.*** Although glass and other types of cookware can be used, metal cookware with thick, smooth, flat bottoms will generally conduct the heat well. Avoid cookware with shaped and rounded bottoms as well as utensils that warp when heated. **Do not heat food in tin foil trays on the cooktop.**

Use cookware of the correct diameter only. The base of the pot or pan should be about as wide as the cooking zone on which it is used – not much wider or much narrower. By using utensils with the correct diameter, you should achieve maximum heating efficiency with the shortest possible boiling times.

Be certain that both the cooktop panel and the bottom of your pots and pans are clean and dry before use. By doing so, you will help prevent scratches and stains.

Operation

READ SAFETY INSTRUCTIONS BEFORE OPERATING YOUR APPLIANCE

How the Elements Operate

This KENYON cooktop contains ribbon-type radiant heating elements. When a power level is set, the element will turn on and “light up”. The power setting determines how hot the burner will get and is electronically regulated which will cause the burner to switch on and off as needed to maintain the selected power level.

The special design of these elements direct the heat up through the ceramic glass providing efficient cooking. Temperature limiters are included in each element to ensure that the safe operating temperature of the ceramic glass top is not exceeded.

Indicator Lights

There are a series of lights that provide indications of burner operation and hot surfaces. These lights are located adjacent to the control panels. When the control is ON, a red light will indicate which burner is on.

For your safety, we have incorporated a “HOT” indicator light. When lit, this light indicates that some part of the glass ceramic cooktop is too warm to touch or place articles upon. Do not place articles other than cookware on the cooking surface while this light is glowing.

After turning off the burner, the “HOT” indicator light will remain illuminated until the cooking zone is safe to touch.

Kenyon PUPS™

Only model numbers that end with PUPS will include this feature.

Kenyon PUPS™ (Pop Up Potholder System) keep pots safe and secure using a very innovative, patented design.

Up Position

Press the soft bumper down, then release and a post “pops” up .6” (15mm) to hold your pot securely in place.

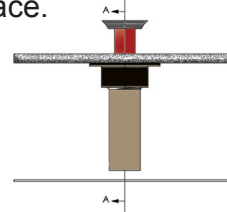

Down Position

When you have finished cooking and the cooking surface has cooled, press the soft bumper down and it will lock in place.

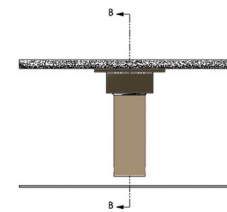

Removal

Removal is only necessary if PUPS™ need to be replaced or are damaged. Do not operate cooktop without PUPS™ installed. Do not remove during operation and when cooktop is HOT. To remove simply unscrew the post by turning it counter clockwise a quarter turn.

Reinstalling

Place the post back into the appropriate location in the glass top and turn it clockwise a quarter turn. This will lock the post into position.

THIS SECTION ONLY PERTAINS TO COOKTOPS THAT HAVE A LOCK FUNCTION. IF YOUR COOKTOP DOES NOT HAVE THIS FEATURE PLEASE SKIP AHEAD TO PAGE 13 AND 14.

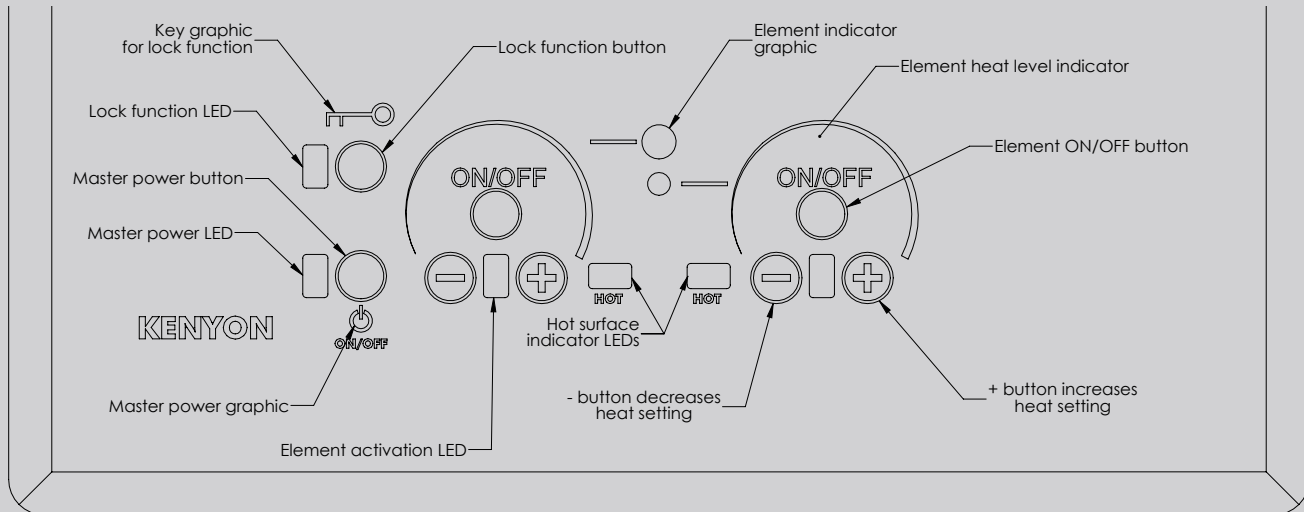

Turning On

Touch the controls firmly with the flat part of your fingertips.

To turn on your cooktop, the master power must first be turned on by placing and holding a finger over the circular area next to the master power graphic for 2 seconds. An audible beep will be heard and a light next to the master power graphic will illuminate. If no further entry is made, the cooktop will turn itself off after a few seconds for safety reasons.

To turn a burner on

Place a finger over the ON/OFF on the control panel for the desired burner. An audible beep will be heard again and a light will illuminate.

The heat level is chosen by holding a finger over the circular areas marked with (+) or (-). Touching the (+) first will incrementally set the heat level from settings 1 thru 8 with a beep corresponding with the number of lights illuminated.

If an element is activated, but no level chosen, the element will automatically turn off in 10 seconds.

Heat Boost

Touching the (-) first will activate the heat boost mode and will set heat level to the highest setting. The setting will start at 8 and incrementally decrease to heat level 1.

To change the heat level

Place a finger on (+) or (-) graphic of desired element to change heat level incrementally up or down.

Turning Off

Touch the circular ON/OFF on the control panel on the desired burner. Touch the ON/OFF graphic for the master power to turn off the entire cooktop.

Master Off

To power off both elements simultaneously, touch the circular area next to the master power ON/OFF graphic. This can be done without deactivation of the elements if any are in operation and acts as an important safety feature. This allows the user a “one touch off” in case of emergencies. All functions will no longer operate until the master power is turned on again.

Operation

Lock Mode

You can lock the entire cooktop at any time during use or when the unit is powered off. Locking the cooktop prevents unwanted cooktop operation.

When the cooktop is locked and the burners are on the heat settings cannot be raised. The settings can only be lowered and the **OFF** function for both burners and **Master Power** will still work for safety reasons.

Locking the cooktop when not in use will prevent the burners from accidentally being turned on. **The lock mode must be turned off before the stove can operate.**

To lock the cooktop

Place finger on the circular area next to the key graphic and hold for 3 seconds. An audible beep will be heard and the light next to the key graphic will illuminate. The cooktop is now locked.

To unlock the cooktop

Touch the circular area next to the key graphic and hold for 3 seconds. An audible beep will be heard and the light next to the key graphic will go out. The cooktop is now unlocked and all functions operate.

Standby mode

Lock mode is independent of all other functions and can be activated at any time, even if the cooktop is in standby mode. Standby mode is when power is available to the cooktop but the master power button is not activated.

Automatic Shut-Off

The cooktop is programmed to automatically shut-off if it is left unattended for an extended period of time. If left on high (8), it will switch off after one hour if no control changes are made. This time period is dependant upon the power level. The lower the power level, the longer the time period (maximum time is 2 hours).

The control will also power off after ten seconds if a heat setting is not selected upon initially applying power to the cooktop. The table below provides the auto shut-off time for each power setting.

SETTING	AUTO SHUT-OFF (min)
1	90
2	90
3	90
4	60
5	60
6	60
7	60
8	60

Temperature Setting Guide

SETTING	USES
1 Bar	Melting butter and chocolate Heating delicate sauces Warming food
2 Bars	Simmering sauces Steaming rice Melting large quantities
3-5 Bars	Steaming vegetables Heating soups, pudding and milk Simmering Frying
5-7 Bars	Sauteing Quick frying Browning Boiling of large quantities
8 Bars	Boiling water Deep frying

THIS SECTION ONLY PERTAINS TO COOKTOPS THAT DO NOT HAVE A LOCK FUNCTION. IF YOUR COOKTOP HAS THIS FEATURE PLEASE REFERENCE PAGES 11 AND 12.

Touch Controls

Power ON Indicator

This display indicates whether the grill is ON or OFF

Power Level Display

Digital display indicates heat output of the selected element. The indicator lamps follow the sweep of the screened graphic. There are eight possible heat levels.

(+) Power Sensor

Touching this sensor will increase the heat output of the selected element in increments of one.

(-) Power Sensor

Touching this sensor will decrease the heat output of the selected element in increments of one.

Power Level Graphic

Depicts the level of heat output by the element. The line sweeps from thin to thick, indicating low to high power.

Master Power Sensor

This is the main power control for the selected element. Touching this with the element OFF will activate the controller and turn the element ON. Touching this sensor with the element on will shut the element OFF.

Calibration

Upon application of electrical power to the cooktop, the controller will run a self-calibration process. The controller will then sound an audible confirmation tone and the display will briefly illuminate. The cooktop is now ready to be used.

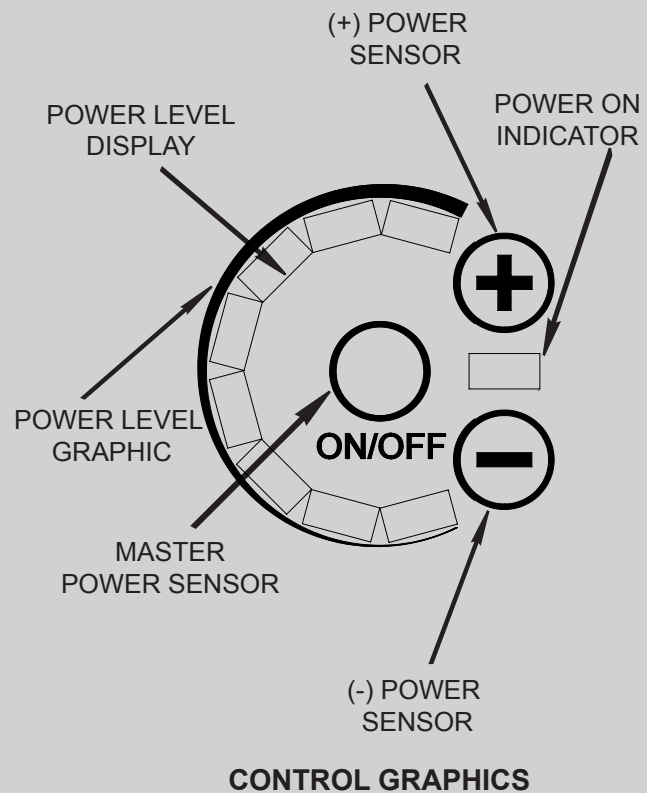

IMPORTANT!

The glass panel must be clean prior to powering on to ensure proper calibration.

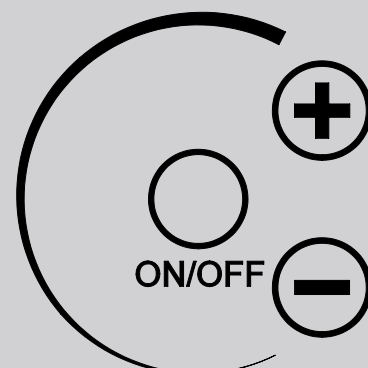

Operation

Energizing the Elements

To turn the selected element ON, touch and hold the Master Power Sensor for two seconds. The controller will then beep and the Power On Indicator will illuminate.

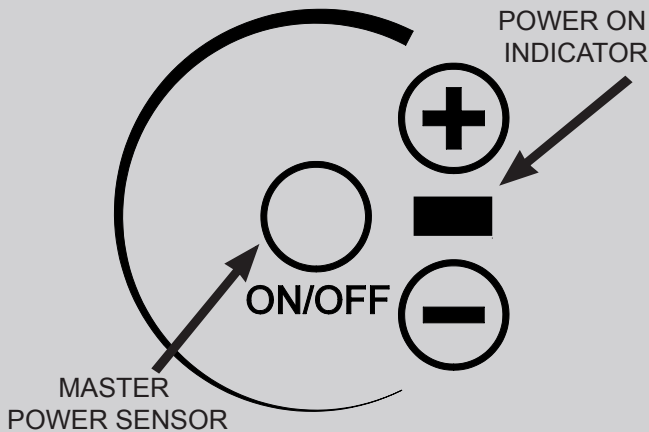

Heat Settings

Your KENYON cooktop has 8 different heat settings, from 1 through 8, selected using the (-) and (+) sensors. The heat setting is displayed as shown below. The heating element cycles at different time intervals to vary the heat level. As the setting is increased, the heating element will remain on for a longer period, increasing the cooking temperature of the grill.

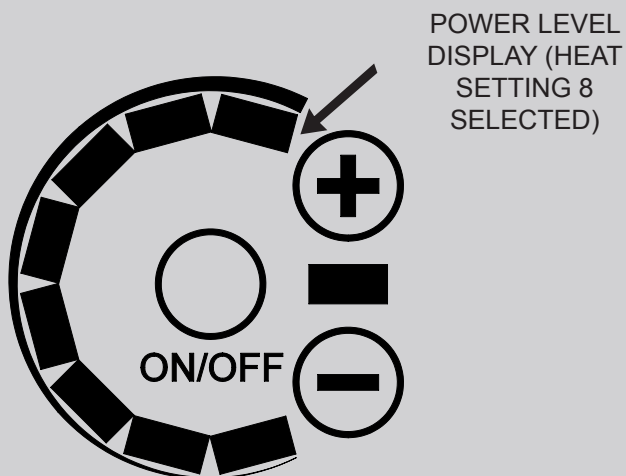

Automatic Shut-Off

The cooktop is programmed to automatically shut-off if it is left unattended for an extended period of time. If left on high (8), it will switch off after one hour if no control changes are made. This time period is dependant upon the power level. The lower the power level, the longer the time period (maximum time is 2 hours).

The control will also power off after ten seconds if a heat setting is not selected upon initially applying power to the cooktop. The table below provides the auto shut-off time for each power setting.

SETTING	AUTO SHUT-OFF (min)
1	90
2	90
3	90
4	60
5	60
6	60
7	60
8	60

Temperature Setting Guide

SETTING	USES
1 Bar	Melting butter and chocolate Heating delicate sauces Warming food
2 Bars	Simmering sauces Steaming rice Melting large quantities
3-5 Bars	Steaming vegetables Heating soups, pudding and milk Simmering Frying
5-7 Bars	Sauteing Quick frying Browning Boiling of large quantities
8 Bars	Boiling water Deep frying



IMPORTANT!

Save this document for future reference. This appliance must be properly installed and grounded by a qualified technician.



IMPORTANT!

Do not remove the clear plastic covering film on the ceramic glass until cooktop is ready to be used.

Check the Electrical Supply Requirements

Unpacking the Cooktop

- 1 Carefully unpack the cooktop from its shipping container. If possible, retain the original shipping carton and protective packaging in the event the unit ever has to be returned for service.

Verify and identify the package contents. The following items should be included in the carton. If any components are missing or damaged, call KENYON immediately.

- 2 This product must be installed in accordance with national, state and local electric codes. The following table provides the correct voltage, amperage and frequency that must be supplied to the cooktop.

The supply must be from an individually grounded circuit that is protected by a circuit breaker and rated per the specifications for the various models as shown in the table on page 16.

PARTS INCLUDED



Lite-Touch Q[®]
Cooktop



(1) Ceramic
cooktop cleaner



(2) Mounting brackets



(1) Package of
mounting screws

**Note model B41570 will not have mounting brackets or screws as it is a portable unit.*

Installation

ELECTRICAL SUPPLY REQUIREMENTS

The supply must be from an individual grounded circuit that is protected by a circuit breaker and rated per the specifications for the various models as shown in the table below.

KENYON PART NUMBER	MAX CONNECTED LOAD	POWER SUPPLY INPUT	MINIMUM WIRE SIZE
B41540PUPS	2600 Watts	120V AC 22A 60Hz	#12 AWG
B41540LPUPS	2600 Watts	120V AC 22A 60Hz	#12 AWG
B40575	2400 Watts	120V AC 20A 60Hz	#12 AWG
B40575L	2400 Watts	120V AC 20A 60Hz	#12 AWG
B40575PUPS	2400 Watts	120V AC 20A 60Hz	#12 AWG
B40575LPUPS	2400 Watts	120V AC 20A 60Hz	#12 AWG
B40579PUPS	2400 Watts	120V AC 20A 60Hz	#12 AWG
B40581LPUPS	2400 Watts	120V AC 20A 60Hz	#12 AWG
B40583PUPS	2400 Watts	120V AC 20A 60Hz	#12 AWG
B40571	1200 Watts	120V AC 10A 60Hz	#14 AWG
B40571PUPS	1200 Watts	120V AC 10A 60Hz	#14 AWG
B41573	1200 Watts	120V AC 10A 60Hz	N/A unit equipped w/ GFCI cord
B40586PUPS	1200 Watts	120V AC 10A 60Hz	#14 AWG
B40589PUPS	1200 Watts	120V AC 10A 60Hz	#14 AWG
B41570	1200 Watts	120V AC 10A 60Hz	N/A unit equipped w/ GFCI cord
B40547	3000 Watts	240V AC 17.5A 60Hz	#10 AWG
B40547PUPS	3000 Watts	240V AC 17.5A 60Hz	#10 AWG
B41541PUPS	3000 Watts	240V AC 12.5A 60Hz	#12 AWG
B41541LPUPS	3000 Watts	240V AC 10A 60Hz	#12 AWG
B40576	1200 Watts	240V AC 10A 60Hz	#14 AWG
B40576L	1200 Watts	240V AC 10A 60Hz	#14 AWG
B40576PUPS	1200 Watts	240V AC 10A 60Hz	#14 AWG
B40576LPUPS	1200 Watts	240V AC 10A 60Hz	#14 AWG
B40580PUPS	1200 Watts	240V AC 10A 60Hz	#14 AWG
B40582LPUPS	1200 Watts	240V AC 10A 60Hz	#14 AWG
B40588PUPS	1200 Watts	240V AC 10A 60Hz	#14 AWG
B40572	1200 Watts	240V AC 5A 60Hz	#14 AWG
B40572PUPS	1200 Watts	240V AC 5A 60Hz	#14 AWG
B41572	1200 Watts	240V AC 5A 60Hz	#14 AWG
B40587PUPS	1200 Watts	240V AC 5A 60Hz	#14 AWG

WARNING!

If the electrical supply does not meet the product specifications, consult with a licensed electrician before proceeding with installation!

Countertop Preparation

3 Please read this section prior to making cutout for cooktop.

It is important to plan ahead for installation of the cooktop, keeping the following dimensions in mind.

A - 13 inches maximum depth of overhead cabinets

B - 36 inches is minimum height of countertop above floor

C - The minimum flat countertop surface that the cooktop will rest upon must be equal to or greater than the overall cooktop dimensions (refer to page 8 for overall cooktop dimensions).

D - 30 inches minimum clearance between the top of the cooking surface and the bottom of an unprotected wood or metal cabinet or 24 inch minimum clearance when the bottom of the wood or metal cabinet is protected by not less than 1/4-inch-thick flame retardant millboard covered with not less than No. 28 MSG sheet steel, 0.015-inch-thick stainless steel, 0.024-inch-thick aluminum or 0.020-inch-thick-copper.

E - 1-inch minimum from backsplash of countertop to edge of glass (refer to the page 6 for overall cooktop dimensions).

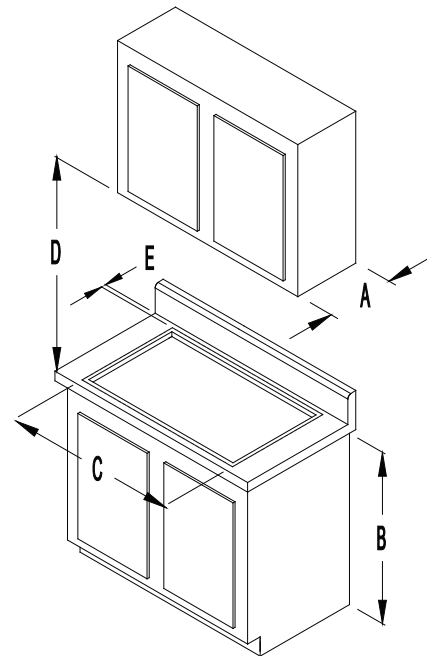

FOR INSTALLATIONS IN CANADA:
“Do Not Install Closer Than 1/2 Inch (12mm) From Any Adjacent Surface”, and
NE PAS INSTALLER A’MDINS DE 12MM DETOUTE SURFACE ADJACENTE.

WARNING!

To eliminate the risk of burns by reaching over heated surface units, cabinet storage space located above surface units should be avoided. If cabinet storage is to be provided, the risk can be reduced by installing a range hood that projects horizontally a minimum of 5” beyond the bottom of the cabinets.

Installation

Countertop Preparation Continued...

Before making the countertop cutout, check for clearance. Check to see if the cooktop will clear the front and side walls of the base cabinet. It is also important to provide enough ventilation.

Adequate ventilation of the space below the countertop must be provided to ensure proper operation of the cooktop. Heat transferred from the cooktop bottom pan during operation will overheat an improperly ventilated area.

Allow a 2" minimum clearance between the bottom of the metal pan of the cooktop and any combustible surface located below, ie: the upper edge of a drawer installed below the cooktop (**see figure below**). Failure to provide proper clearances and ventilation may result in a fire hazard.

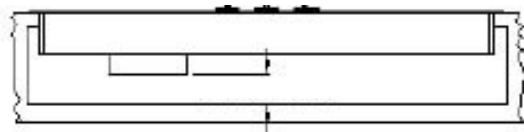

2 INCH (51mm) MINIMUM

Installing the Cooktop

- 4 The cooktop is supplied with two metal mounting brackets. These brackets are designed to hold the cooktop firmly in place. The cooktop does not have a metal frame and should be sealed to the countertop. **Use a soft bedding compound that will prevent damage if later removal for service is necessary. We recommend a nonadhesive type of sealant, such as plumber's putty, maximum compressed thickness of 1/16".**

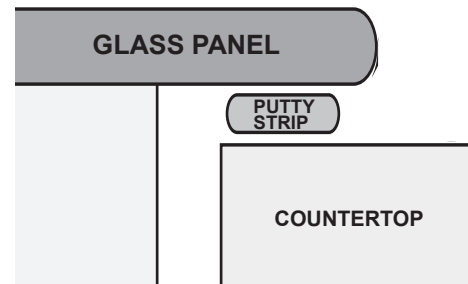

Attach the two mounting brackets as shown (**see figure below**) to the inside vertical surface of the cutout. The brackets are to be mounted on opposing sides. If your counter material is granite you will need to glue two wood strips underneath the counter to accept the mounting brackets. Center the bracket in the opening, **flush with the countertop** and secure with #6 self-tapping screws that are provided. Position the cooktop in the cutout opening and press firmly on all sides to seal the glass into the bedding compound. Secure the cooktop to the brackets from underneath with the small sheet metal screws that are supplied.

BE CAREFUL NOT TO OVERTIGHTEN THE SCREWS.

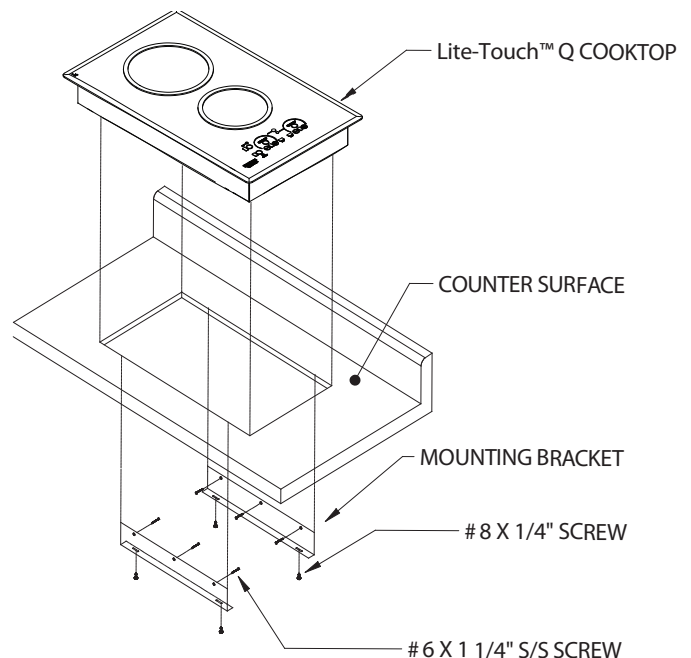

Electrical Connection

- 5** Before proceeding further, verify that the power supply is disconnected. Verify that the appropriate electrical supply requirements have been met. Please refer to the table on page 16 for appropriate electrical requirements. The cooktop is supplied with a 36-inch long conduit for a connection to an accessible junction box. The 240V conduit consists of three insulated wires. There are two insulated hot lead conductors (red and black) and one insulated ground conductor (green). The 120V conduit consists of three insulated wires. There is the hot lead conductor (black), the neutral conductor (white) and one insulated ground conductor (green).

Attach conductor wires to residence wiring in accordance with national, state and local electric codes.



WARNING!

The entire appliance must be grounded at all times when the electrical power supply is on. Do not ground the appliance with the neutral house supply wire (white). A separate ground must be used.

Final Preparations Prior to Use

- 6** Remove the plastic film from the cooktop. Clean the cooktop before you use it for the first time. A thorough cleaning with a recommended cooktop cleaner (**Cerama Bryte Ceramic Cooktop Cleaner**) will provide a clean, shiny coating on the cooktop surface.

Warranty

Kenyon International, Inc (the “Company”) warrants its products in normal usage to be free of defects in materials and workmanship subject to the conditions and limitations below. Any part, which proves to be defective in normal usage during the warranty period will be repaired or replaced by the Company.

This warranty covers certain products built by the Company and is subject to the following conditions and limitations:

1. The Company’s liability shall be limited to repair or replacement (choice of remedy at Company’s option) of goods or parts as may be defective in materials or workmanship. This liability is limited to three years from the date of original installation; this warranty covers parts and labor at approved Company rates, \$75 per hour.
2. Determination of suitability of the product for the use contemplated by the buyer is the sole responsibility of the Buyer and the Company shall have no responsibility in connection with such suitability.
3. The Company shall not be liable for any damage resulting from:
 - failures due to use of the product in applications for which they are not intended
 - failures due to corrosion, wear and tear, abuse or improper installation or maintenance
4. The Company shall be responsible for ground shipping charges to the location of the appliance (home) within the continental United States and Canada. Any duties, express or special shipping charges are at the expense of the Buyer.
5. All labor allowed by the Company under this warranty must be performed by an Authorized Kenyon International Service Center, unless otherwise specified in writing by the Company.
6. This warranty does not cover the cost of repair or replacement due to damage of any glass surface, cooking grates or cooking griddles.

THERE ARE NO OTHER WARRANTIES OF MERCHANTABILITY, FITNESS FOR PURPOSE OR ANY OTHER KIND, EXPRESSED OR IMPLIED AND NONE SHALL BE IMPLIED BY LAW. The duration of any such warranties that are nevertheless implied by law for the benefit of a consumer, shall be limited to a period of three years from original purchase by the user. Some countries do not allow limitations on how long an implied warranty lasts, so this limitation may not apply to you.

THE COMPANY SHALL NOT BE LIABLE FOR CONSEQUENTIAL OR INCIDENTAL DAMAGES ARISING FROM THE BREACH OF THIS WARRANTY, WHETHER EXPRESSED, IMPLIED OR STATUTORY. Some countries or states do not allow exclusion or limitation of consequential or incidental damages so this limitation or exclusion may not apply to you.

THIS WARRANTY GIVES YOU SPECIFIC LEGAL RIGHTS AND YOU MAY ALSO HAVE OTHER LEGAL RIGHTS THAT MAY VARY FROM COUNTRY TO COUNTRY AND STATE TO STATE.

Kenyon International, Inc.
P.O. Box 925 • 8 Heritage Park Road • Clinton, CT 06413 USA
Phone (860) 664-4906 FAX: (860) 664-4907