

This catalog covers:
FR651V-□S00

GRID NO. This grid covers:
A-01 TITLE

PARTS CATALOG

4-STROKE ENGINE

FR651V

PRODUCT CODE	NOTE
FR651V-FS00	STD

PARTS CATALOG INTRODUCTION

This parts catalog lists parts and sub-assemblies provided as service parts. When it becomes necessary to replace parts, always use KAWASAKI GENUINE PARTS which have passed strict inspection which guarantees quality and performance.

1. HOW TO ORDER PARTS

- When ordering the parts, be sure to use the parts catalog corresponding to the product code. Check the product revision codes on the product and the catalog.
Product Code (example) : FA130D-**A**A00
Product Revision Code
- Specify the part code (all digits) exactly as listed in this catalog on your parts order.
- The parts not shown in the illustrations of this catalog are not sold separately; only the complete units or next higher assemblies illustrated are supplied as the service parts.

2. EXPLANATION OF PARTS CATALOG FORMAT

This catalog covers: **FH500V-□S14** GRID NO. **B-03** This grid covers: **CYLINDER/CRANKCASE**

Ref. No.	Part No.	Description	Quantity	
			A	B
11004	11004-7001	GASKET-HEAD	2	2
11008	11008-7001	HEAD-COMP-CYLINDER,#1	1	1
11022	11022-7002	HEAD-COMP-CYLINDER,#2	1	1
11022	11022-7001	CASE-ROCKER	2	2
11060	11060-7001	GASKET,ROCKER CASE	2	2
11060A	11060-7008	GASKET,CRANKCASE COVER	1	1
11209B	11209-7015	GASKET,BREATHER	1	1
13271	13271-7016	PLATE	1	1
13271A	13271-7016	COVER,BREATHER	1	1
14090	14090-7001	COVER,BREATHER	1	1
49015	49015-6215	COVER-CRANKCASE	1	1
49109	49109-7002	ELEMENT-BREATHER	1	1
49120	49120-6119	CRANKCASE-COMP	1	1
92033	92033-7003	RING-SNAP	2	2
92043	92043-7001	PIN	6	6
92049	92049-7001	SEAL-OIL	4	4
92049A	92049-7002	SEAL-OIL	1	1
92049B	92049-7004	SEAL-OIL	1	1
92049C	92049-7005	SEAL-OIL	1	1
130	130B0612	BOLT-FLANGED	4	4
130A	130B0640	BOLT-FLANGED	4	4
130B	130T0850	BOLT-FLANGED	17	17
130C	130T0875	BOLT-FLANGED	2	2
172	172G0818	BOLT-STUD	4	4

4) Part Number

This is the key of your parts ordering. Three kinds of part number are used in this catalog.

- Structure 1
□□□□□□-□□□□□□-□□
Part Revision Code
- Structure 2
□□□□□□-□□□□□□-□□
Color Code for Painted Part
- Standard Hardware Number
(for bolts, nuts, washer, or the like)
□□□□□□□□
Size Code
Material and Surface Treatment Code
Item Code

5) Description and Additional Information

The part name, the location, the size, and the serial number as additional information, etc. are described here. Use them to find out and check the part required.

When a part number is changed without change of the product revision code and the changed parts are not interchangeable, the serial number of the product is noted as follows;

- (- FA130 - 100001) : Affected units are from beginning of the product of the product code up to and including this serial number.
- (FA130 - 100002 -) : Affected units are from this serial number and above.
- (FA130 - 100002 - FA130 - 110001) : Affected units are in this serial number range.

6) Quantity

The figure shows quantity of the part required at the indicated position on the illustration and for the specified product revision code.

The asterisk (*) on this column means the part can be used as the substitute on the product and is supplied until the stock is exhausted.

Note:Some small parts will be supplied by units.

Example: If six (6) bolts are ordered and the minimum quantity per unit is five (5), two (2), units of the bolt will be delivered.

7) Product Revision Code

This Code indicates an important change which affects the service parts interchangeability.

3. ABBREVIATIONS

#	Number	FR	Front	RH	Right Hand
&	And	G	Gram	RPM ...	Revolutions Per Minute
(+)	Plus	HEX	Hexagonal	RR	Rear
(-)	Minus	ID=	Inside Diameter	STD	Standard
2ND	Second	IN	Inch	T	Teeth
3RD	Third	L=	Length	T=	Thickness
4TH	Fourth	LH	Left Hand	U/S	Under Size
A	Ampere	LWR	Lower	UPP	Upper
AR	As Required	MM	Millimeter	V	Volt
ASSY	Assembly	O/S	Over Size	W	Watt
CNT	Center	OD=	Outside Diameter		
COMP	Complete	REF	Reference		

1) Product Code

This code describes the product code covered by this catalog. The product revision code, which is a part of the product code, is omitted.

2) Part Group Title

This title is the representative name for the group of parts illustrated on the page.

3) Reference Number

The reference numbers are shown on the illustration and the list as the link between them.

E0110-A800B

B-03 CYLINDER/CRANKCASE

E0120-A398A

B-04 PISTON/CRANKSHAFT

E0130-A176A

B-05 VALVE/CAMSHAFT

E0140-A506A

B-06 LUBRICATION-EQUIPMENT

E0150-B163A

B-07 COOLING-EQUIPMENT

E0160-B605A

B-08 ELECTRIC-EQUIPMENT

This catalog covers:
FR651V- □ S00

GRID NO. This grid covers:
B-02 PICTORIAL INDEX

E0170-A753A

B-09 CONTROL-EQUIPMENT

E0180-A964B

B-10 CARBURETOR

E0190-B233D

B-11 AIR-FILTER/MUFFLER

This catalog covers:

FR651V- □ S00

GRID NO.

C-01

This grid covers:

PICTORIAL INDEX

E0200-A837A

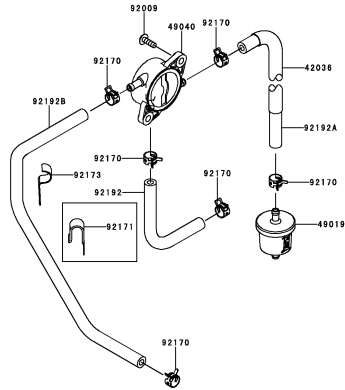

C-03

FUEL-TANK/FUEL-VALVE

E0210-A623A

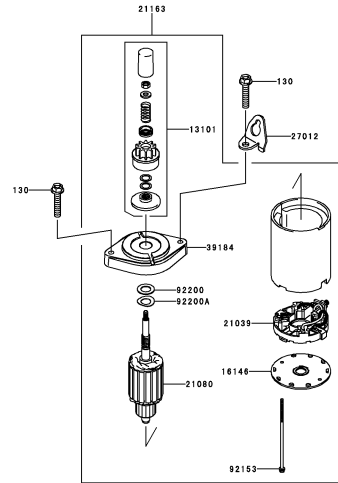

C-04

STARTER

This catalog covers:

FR651V- □ S00

GRID NO.

D-01

This grid covers:

PICTORIAL INDEX

F0290-B755B

56033

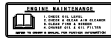

56071



56080



D-03

LABEL

This catalog covers:

FR651V- □ S00

GRID NO.

B-03

This grid covers:

CYLINDER/CRANKCASE

E0110-A800B

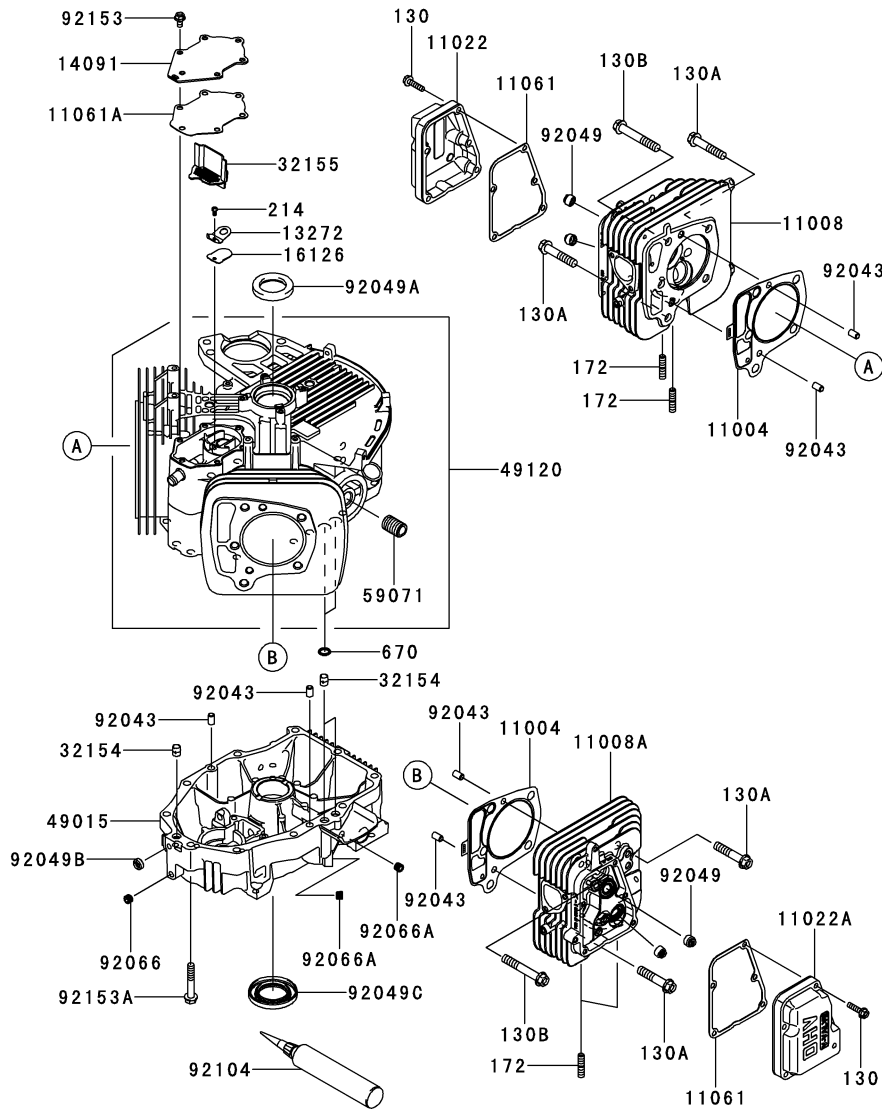

Ref. No.	Part No.	Description	Quantity
11004	11004-7026	GASKET-HEAD	2
11008	11008-7039	HEAD-COMP-CYLINDER,#1	1
11008A	11008-7040	HEAD-COMP-CYLINDER,#2	1
11022	11022-0710	CASE-ROCKER,#1	1
11022A	11022-0711	CASE-ROCKER,#2	1
11061	11061-7083	GASKET,CASE-ROCKER	2
11061A	11061-7094	GASKET,BREATHER	1
13272	13272-1374	PLATE	1
14091	14091-7064	COVER,BREATHER	1
16126	16126-7020	VALVE,BREATHER	1
32154	32154-7019	PIPE	3
32155	32155-7003	PIPE,BREATHER	1
49015	49015-7106	COVER-CRANKCASE	1
49120	49120-0733	CRANKCASE-COMP	1
59071	59071-7025	JOINT	1
92043	92043-1263	PIN	6
92049	92049-7001	SEAL-OIL,RVC2 6X11X10.2	4
92049A	92049-7010	SEAL-OIL,SD 35X48X8 R HS	1
92049B	92049-7019	SEAL-OIL,SO 8X14X5 HS	1
92049C	92049-7028	SEAL-OIL,38X62X8MTCLV	1
92066	92066-0761	PLUG	1
92066A	92066-0762	PLUG	2
92104	92104-7001	GASKET-LIQUID,TB1217H	AR
92153	92153-7043	BOLT,6X12	6
92153A	92153-7054	BOLT,8X50	10
130	130AA0625	BOLT-FLANGED,6X25	10
130A	130CA1050	BOLT-FLANGED,10X50	4
130B	130CA1065	BOLT-FLANGED,10X65	6
172	172BA0818	BOLT-STUD,8X18	4
214	214AA0408	SCREW-PAN+,-,4X8	1
670	670B2011	O RING,11MM	2

This catalog covers:

FR651V- □ S00

GRID NO.

B-04

This grid covers:

PISTON/CRANKSHAFT

E0120-A398A

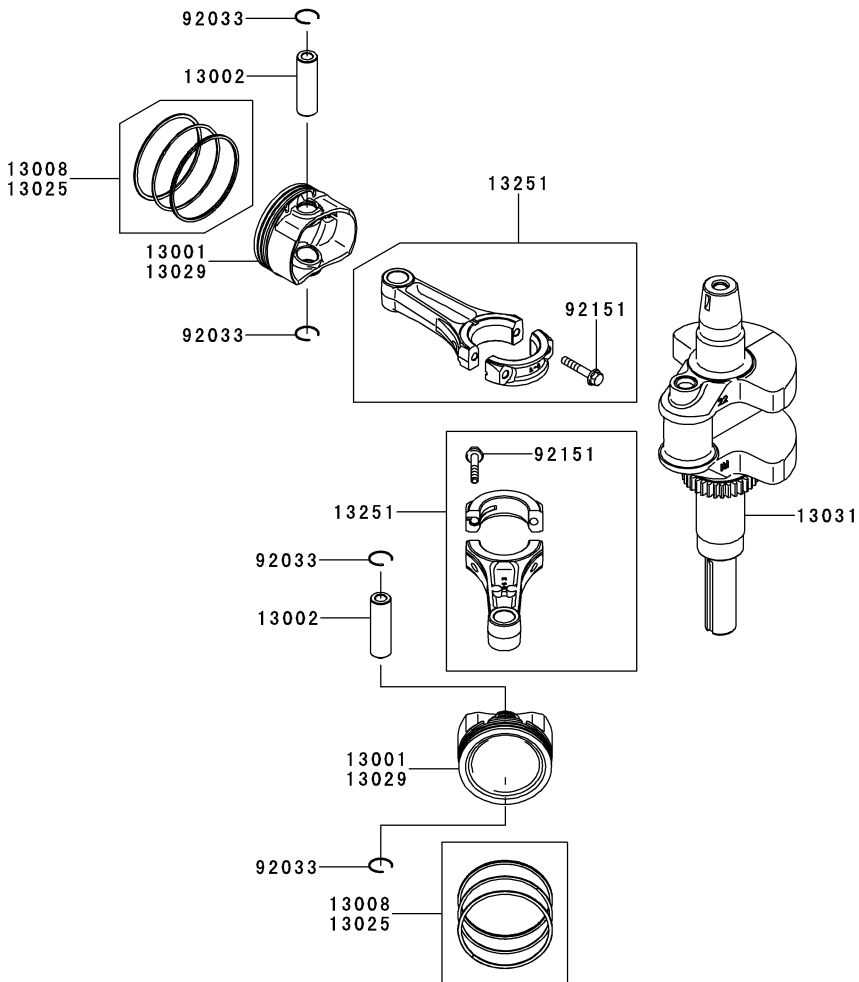

Ref. No.	Part No.	Description	F	Quantity
13001	13001-7027	PISTON-ENGINE		2
13002	13002-0704	PIN-PISTON		2
13008	13008-7005	RING-SET-PISTON		2
13025	13025-7009	RING-SET-PISTON L,0.5	AR	
13029	13029-7010	PISTON-ENGINE L,0.5	AR	
13031	13031-0747	CRANKSHAFT-COMP		1
13251	13251-7025	ROD-ASSY-CONNECTING		2
92033	92033-7018	RING-SNAP		4
92151	92151-7017	BOLT,6X35		4

This catalog covers:

FR651V- □ S00

GRID NO.

B-05

This grid covers:

VALVE/CAMSHAFT

E0130-A176A

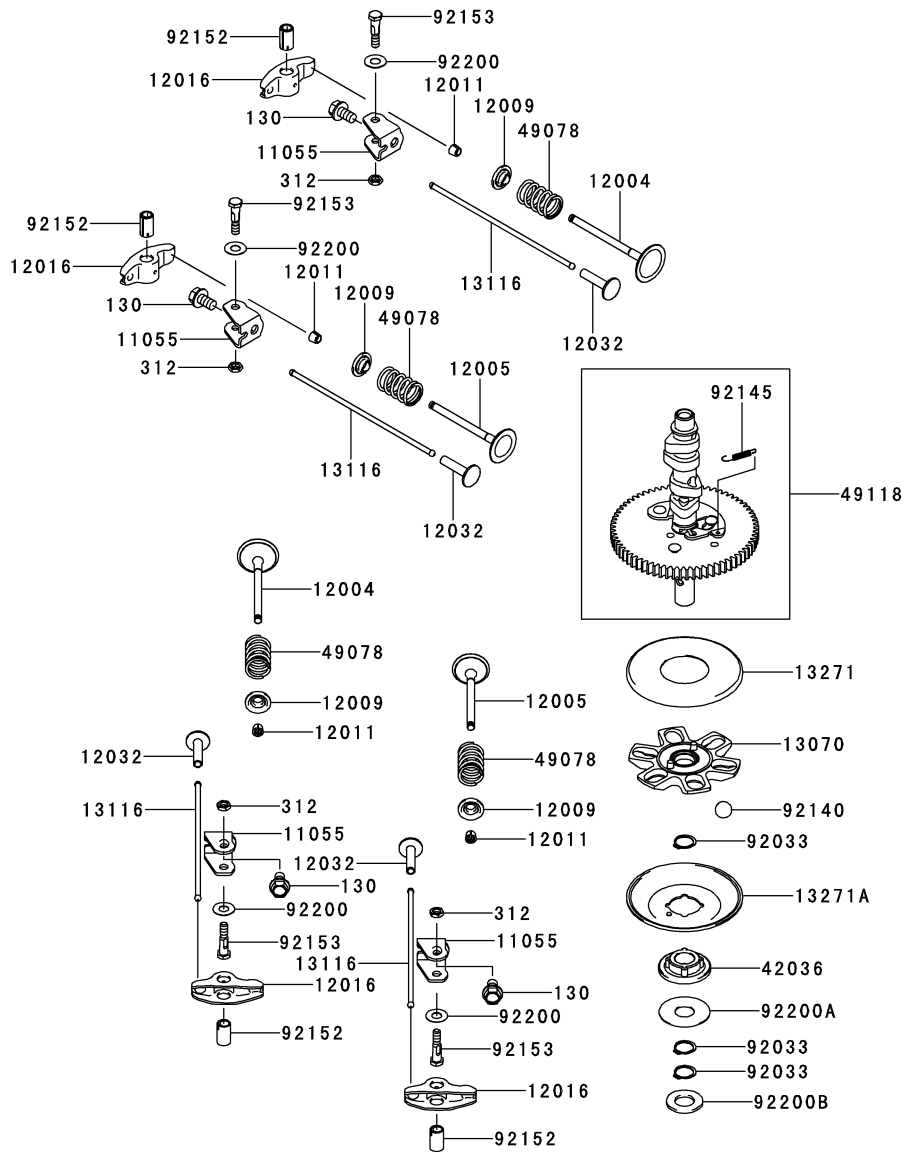

Ref. No.	Part No.	Description	Quantity
11055	11055-7009	BRACKET	4
12004	12004-0705	VALVE-INTAKE	2
12005	12005-0720	VALVE-EXHAUST	2
12009	12009-7001	RETAINER-VALVE SPRING	4
12011	12011-2056	COLLET	8
12016	12016-2066	ARM-ROCKER	4
12032	12032-7001	TAPPET	4
13070	13070-7017	GUIDE, GOVERNOR	1
13116	13116-7007	ROD-PUSH	4
13271	13271-7007	PLATE	1
13271A	13271-7021	PLATE, GOVERNOR	1
42036	42036-7021	SLEEVE	1
49078	49078-7002	SPRING-ENGINE VALVE, IN	4
49118	49118-7022	CAMSHAFT-COMP	1
92033	92033-0727	RING-SNAP	3
92140	92140-7005	BALL	6
92145	92145-7001	SPRING	1
92152	92152-1689	COLLAR	4
92153	92153-7100	BOLT, 6X29.5	4
92200	92200-2151	WASHER, 8.1X18X0.5	4
92200A	92200-7009	WASHER, 16X42X0.91	1
92200B	92200-7048	WASHER, 16.3X30X2.28	1
130	130AA0814	BOLT-FLANGED, 8X14	4
312	312AA0600	NUT-HEX, 6MM	4

This catalog covers:

FR651V- □ S00

GRID NO.

B-06

This grid covers:

LUBRICATION-EQUIPMENT

E0140-A506A

Ref. No.	Part No.	Description	F	Quantity
13272	13272-7011	PLATE, ROTOR	1	
14075	14075-7013	CAP-ASSY, OIL GAUGE	1	
16154	16154-7010	ROTOR-PUMP, OUTER	1	
16154A	16154-7011	ROTOR-PUMP, INNER	1	
49065	49065-7006	FILTER-OIL	1	
49065A	49065-7007	FILTER-OIL	1	
59231	59231-0712	FILLER	1	
92066	92066-7003	PLUG	1	
92140	92140-7003	BALL	1	
92145	92145-7002	SPRING	1	
92153	92153-7008	BOLT	1	
92153A	92153-7043	BOLT, 6X12	3	
555	555A0420	PIN-SPRING, 4X20	1	
670	670D2016	O RING, 16MM	2	

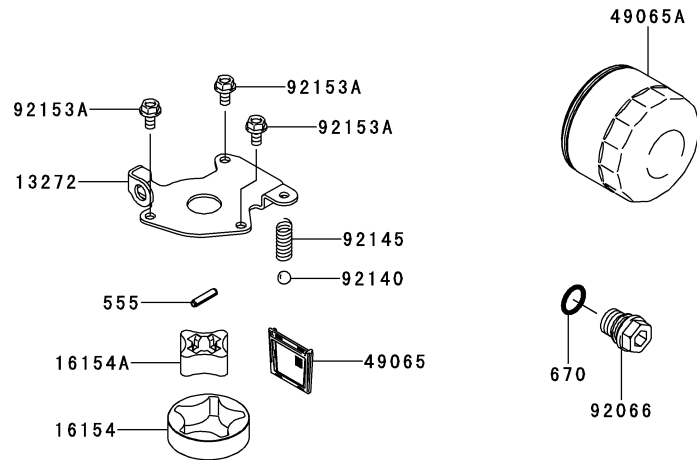
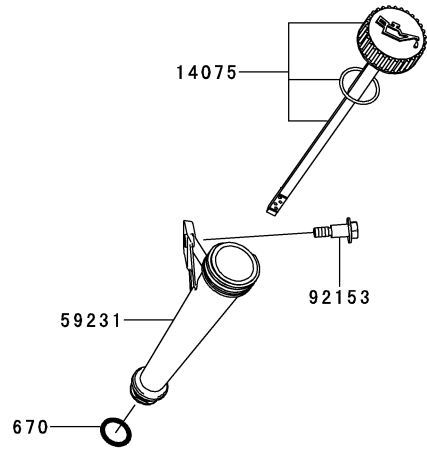

This catalog covers:

FR651V- □ S00

GRID NO.

B-07

This grid covers:

COOLING-EQUIPMENT

E0150-B163A

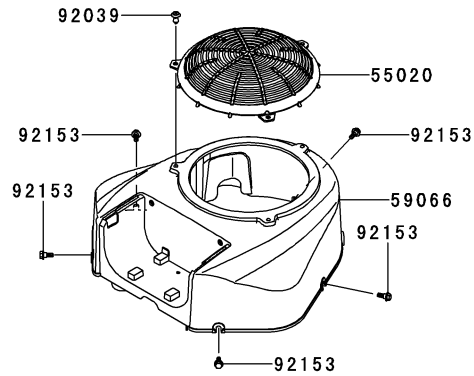

Ref. No.	Part No.	Description	F	Quantity
13272	13272-7006	PLATE,FAN	1	
14037	14037-7008-9H	SCREEN	1	
23062	23062-7024	BRACKET-COMP	1	
49089	49089-7079	SHROUD-ENGINE	1	
49089A	49089-7080	SHROUD-ENGINE	1	
55020	55020-0900	GUARD	1	
59041	59041-7014	FAN	1	
59066	59066-0014	HOUSING-FAN	1	
92026	92026-7007	SPACER	1	
92039	92039-7004	RIVET,GUARD	3	
92151	92151-7012	BOLT,6X12	3	
92153	92153-7007	BOLT	9	
92153A	92153-7043	BOLT,6X12	4	

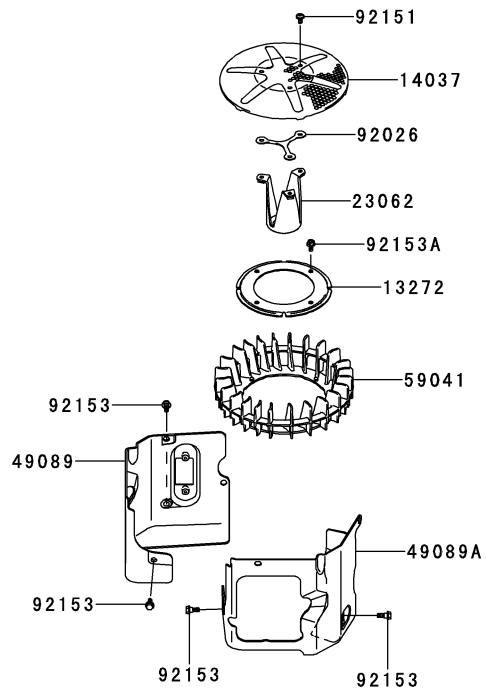

This catalog covers:

FR651V- □ S00

GRID NO.

B-08

This grid covers:

ELECTRIC-EQUIPMENT

E0160-B605A

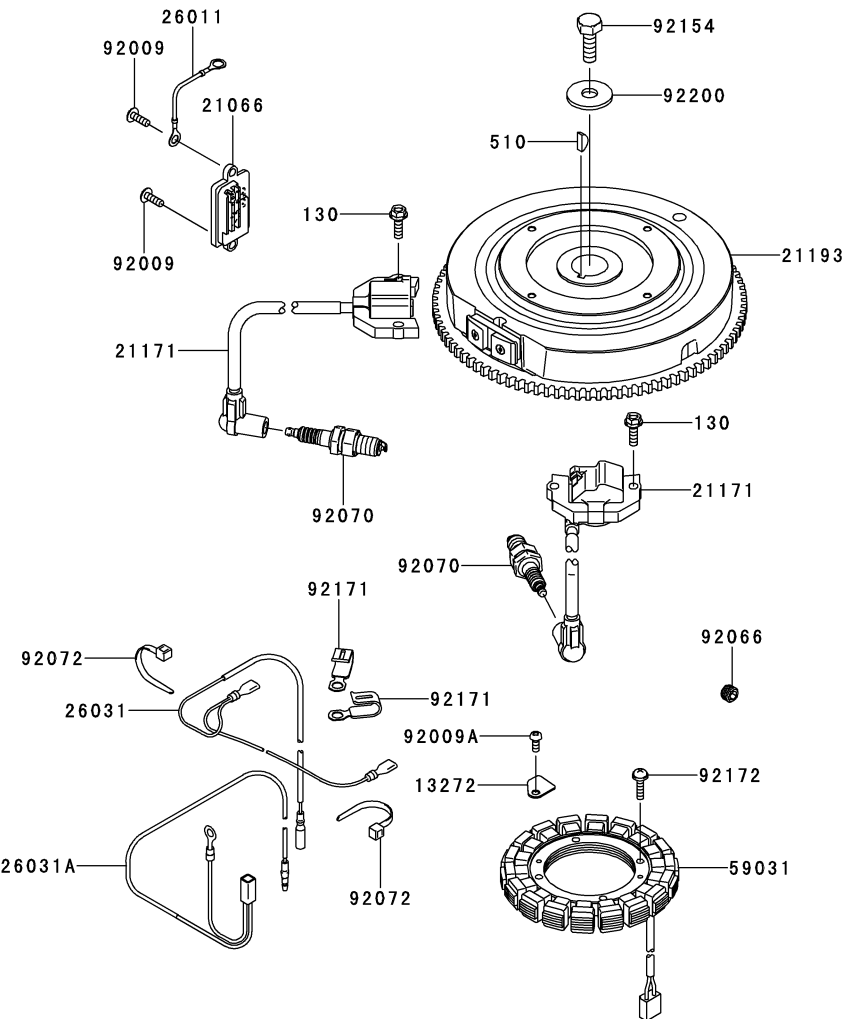

Ref. No.	Part No.	Description	Quantity
13272	13272-7012	PLATE	1
21066	21066-7017	REGULATOR-VOLTAGE	1
21171	21171-0711	COIL-ASSY-IGNITION	2
21193	21193-7038	FLYWHEEL-ASSY	1
26011	26011-7025	WIRE-LEAD,L=95	1
26031	26031-7040	HARNESS	1
26031A	26031-7041	HARNESS	1
59031	59031-7017	COIL-CHARGING	1
92009	92009-2303	SCREW	2
92009A	92009-2308	SCREW	1
92066	92066-0762	PLUG	1
92070	92070-7004	PLUG-SPARK,BPR4ES(NGK),SOLID	2
92072	92072-7003	BAND	2
92154	92154-7003	BOLT,12X30	1
92171	92171-7008	CLAMP	2
92172	92172-7018	SCREW,5X20	4
92200	92200-7002	WASHER	1
130	130AA0620	BOLT-FLANGED,6X20	4
510	510A5100	KEY-WOODRUFF	1

This catalog covers:

FR651V- □ S00

GRID NO.

B-09

This grid covers:

CONTROL-EQUIPMENT

E0170-A753A

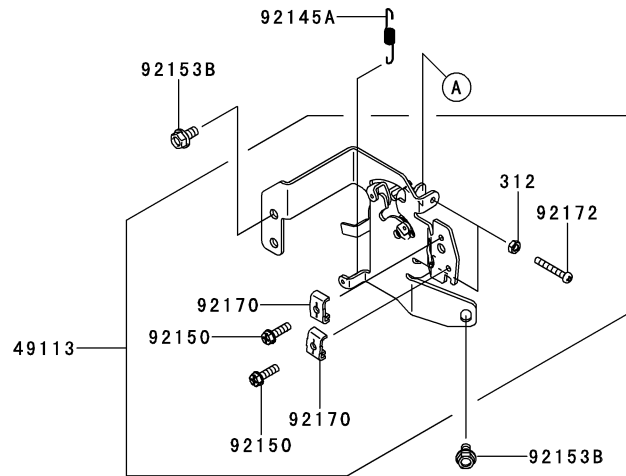

Ref. No.	Part No.	Description	F	Quantity
13107	13107-7047	SHAFT,GOVERNOR	1	
13271	13271-7038	PLATE	1	
16171	16171-7022	LINK	1	
39129	39129-7028	SPRING-GOVERNOR	1	
49103	49103-7014	ARM-GOVERNOR	1	
49103A	49103-7015	ARM-GOVERNOR	1	
49113	49113-0727	PANEL-COMP-CONTROL	1	
92145	92145-7057	SPRING	1	
92145A	92145-7058	SPRING	1	
92150	92150-2182	BOLT,5X18	2	
92153	92153-0009	BOLT,6X12	1	
92153A	92153-7033	BOLT,6X35	1	
92153B	92153-7043	BOLT,6X12	2	
92170	92170-7001	CLAMP	2	
92172	92172-0792	SCREW,5X35	2	
214	214AA0408	SCREW-PAN+,-,4X8	2	
311	311AA0600	NUT-HEX,6MM	1	
312	312AA0500	NUT-HEX,5MM	2	
411	411AA0600	WASHER-PLAIN,6MM	1	

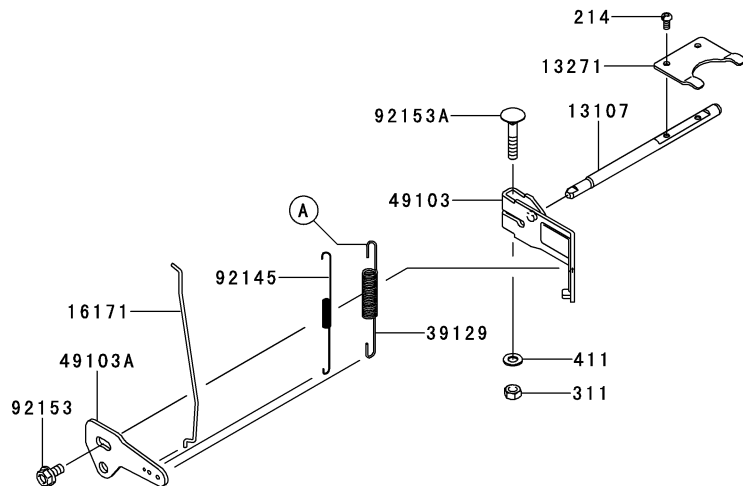

This catalog covers:

FR651V- □ S00

GRID NO.

B-10

This grid covers:

CARBURETOR

E0180-A964B

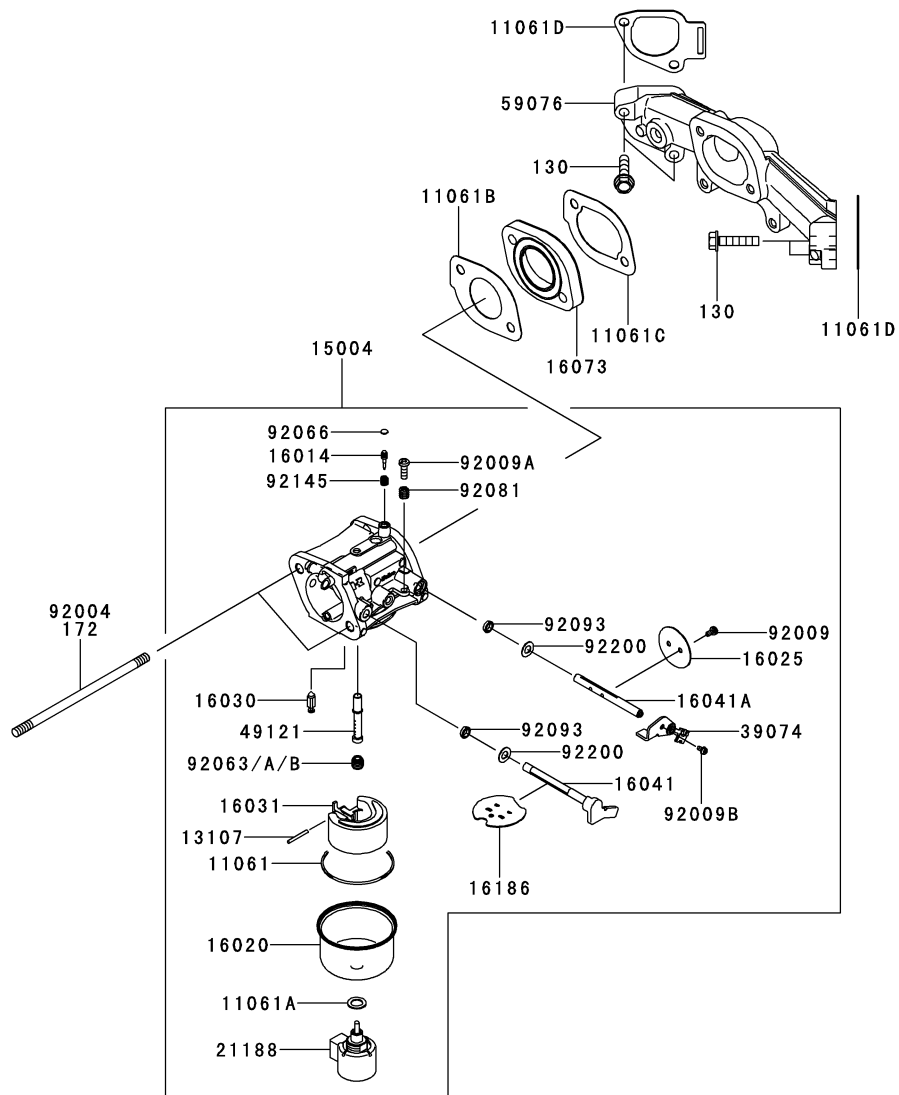

Ref. No.	Part No.	Description	F	Quantity
11061	11061-7009	GASKET,CHAMBER	1	
11061A	11061-7010	GASKET,SCREW	1	
11061B	11061-7087	GASKET,INSULATOR	1	
11061C	11061-7088	GASKET,INSULATOR/MANIFOLD	1	
11061D	11061-7093	GASKET,MANIFOLD	2	
13107	13107-7018	SHAFT	1	
15004	15004-0828	CARBURETOR-ASSY	1	
16014	16014-7010	SCREW-PILOT AIR	1	
16020	16020-7003	CHAMBER-FLOAT	1	
16025	16025-7017	VALVE-THROTTLE	1	
16030	16030-7003	VALVE-FLOAT	1	
16031	16031-7002	FLOAT	1	
16041	16041-0007	SHAFT-CARBURETOR,CHOKE	1	
16041A	16041-7051	SHAFT-CARBURETOR,THROTTLE	1	
16073	16073-7013	INSULATOR	1	
16186	16186-7006	VALVE-ASSY-CHOKE	1	
21188	21188-7002	SOLENOID	1	
39074	39074-7001	LEVER-ASSY-THROTTLE	1	
49121	49121-7018	NOZZLE-MAIN	1	
59076	59076-7019	MANIFOLD-INTAKE	1	
92004	92004-0723	BOLT-STUD,6X115	2	
92009	92009-2083	SCREW	2	
92009A	92009-2349	SCREW	1	
92009B	92009-2402	SCREW	1	
92063	92063-7141	JET-MAIN,#122,3280FT	AR	
92063A	92063-7142	JET-MAIN,#124	1	
92063B	92063-7149	JET-MAIN,#120,6560FT	AR	
92066	92066-7032	PLUG	1	
92081	92081-2234	SPRING	1	
92093	92093-0593	SEAL	2	
92145	92145-2122	SPRING	1	
92200	92200-0848	WASHER	2	
130	130AA0630	BOLT-FLANGED,6X30	4	
172	172BA06115	BOLT-STUD,6X115	*	

This catalog covers:

FR651V- □ S00

GRID NO.

B-11

This grid covers:

AIR-FILTER/MUFFLER

E0190-B233D

Ref. No.	Part No.	Description	F	Quantity
11011	11011-7052	CASE-AIR FILTER	1	
11013	11013-0726	ELEMENT-AIR FILTER	1	
11060	11060-7016	GASKET,MUFFLER	2	
11061	11061-7086	GASKET,CARBURETOR/PIPE-INTAKE	1	
16060	16060-7038	PIPE-INTAKE	1	
42036	42036-7022	SLEEVE,BREATHER	1	
92009	92009-2303	SCREW	2	
92015	92015-1367	NUT	2	
92066	92066-0095	PLUG	1	
92170	92170-2042	CLAMP	1	
92173	92173-1001	CLAMP	1	
92173A	92173-7003	CLAMP	2	
92173B	92173-7010	CLAMP	1	
92192	92192-7146	TUBE,12.6X18.6X118	1	
92192A	92192-7165	TUBE	1	
92210	92210-7027	NUT,M8	4	
461	461DA0800	WASHER-SPRING,8MM	4	

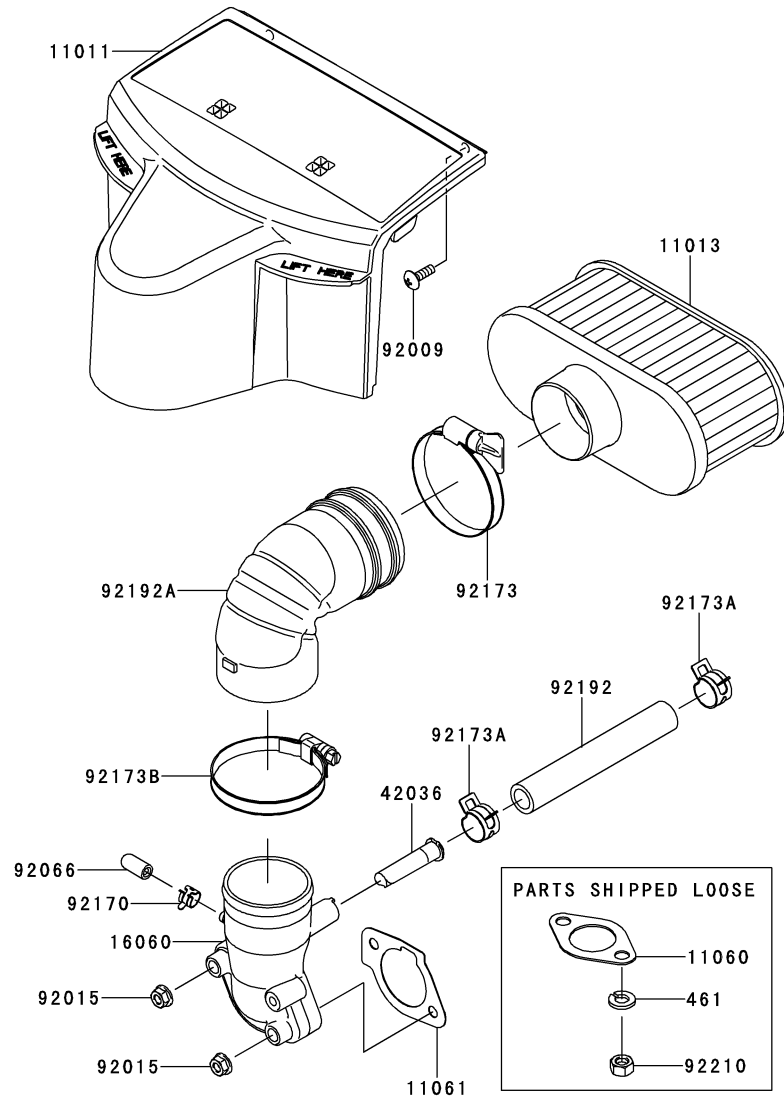

This catalog covers:

FR651V- □ S00

GRID NO.

C-03

This grid covers:

FUEL-TANK/FUEL-VALVE

E0200-A837A

Ref. No.	Part No.	Description	F	Quantity
42036	42036-7015	SLEEVE	1	
49019	49019-0014	FILTER-FUEL	1	
49040	49040-7008	PUMP-FUEL	1	
92009	92009-2303	SCREW	2	
92170	92170-2009	CLAMP	6	
92171	92171-7008	CLAMP	*	
92173	92173-1000	CLAMP	1	
92192	92192-7148	TUBE,6.4X12.7X150	1	
92192A	92192-7172	TUBE,6.35X12.7X185	1	
92192B	92192-7188	TUBE,6.35X12.7X390	1	

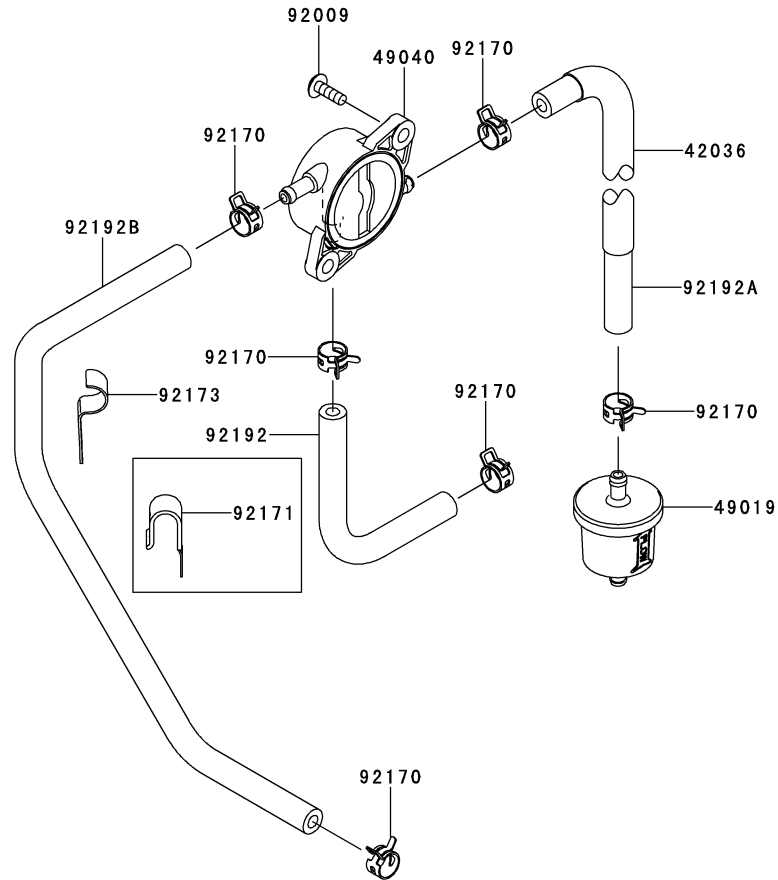

This catalog covers:

FR651V- □ S00

GRID NO.

C-04

This grid covers:

STARTER

E0210-A623A

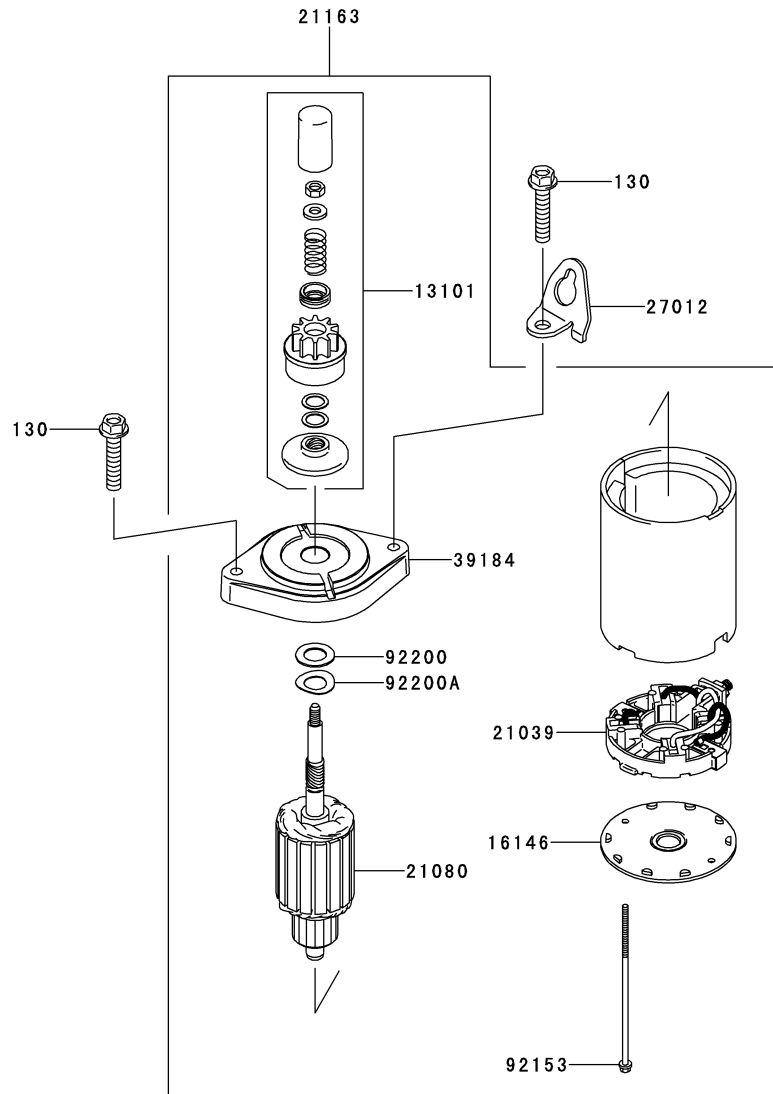

Ref. No.	Part No.	Description	F	Quantity
13101	13101-7010	GEAR-ASSY	1	1
16146	16146-7013	COVER-ASSY	1	1
21039	21039-7002	BRUSH	1	1
21080	21080-0005	ARMATURE	1	1
21163	21163-0727	STARTER-ELECTRIC	1	1
27012	27012-7008	HOOK	1	1
39184	39184-0020	BRACKET-ASSY	1	1
92153	92153-7034	BOLT	2	2
92200	92200-7023	WASHER	1	1
92200A	92200-7024	WASHER	1	1
130	130BA0840	BOLT-FLANGED,8X40	2	2

This catalog covers:

FR651V- □ S00

GRID NO.

D-03

This grid covers:

LABEL

F0290-B755B

Ref. No.	Part No.	Description	F	Quantity
56033	56033-7001	LABEL-MANUAL		1
56071	56071-0216	LABEL-WARNING		1
56080	56080-0750	LABEL-BRAND		1

56033

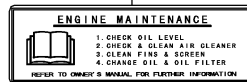

56071



56080



This catalog covers:

FR651V- □ S00

GRID NO.

H-09

This grid covers:

PART NAME INDEX

AIR-FILTER/MUFFLER	B-11
CARBURETOR	B-10
CONTROL-EQUIPMENT	B-09
COOLING-EQUIPMENT	B-07
CYLINDER/CRANKCASE	B-03
ELECTRIC-EQUIPMENT	B-08
FUEL-TANK/FUEL-VALVE	C-03
LABEL	D-03
LUBRICATION-EQUIPMENT	B-06
PISTON/CRANKSHAFT	B-04
STARTER	C-04
VALVE/CAMSHAFT	B-05

This catalog covers:

FR651V- □ S00

GRID NO.

H-10

This grid covers:

NUMERICAL PARTS INDEX

Part No.	Grid No.	Part No.	Grid No.	Part No.	Grid No.	Part No.	Grid No.	Part No.	Grid No.
11004-7026	B-03	16060-7038	B-11	59071-7025	B-03	92170-2009	C-03		
11008-7039	B-03	16073-7013	B-10	59076-7019	B-10	92170-2042	B-11		
11008-7040	B-03	16126-7020	B-03	59231-0712	B-06	92170-7001	B-09		
11011-7052	B-11	16146-7013	C-04	670B2011	B-03	92171-7008	B-08		
11013-0726	B-11	16154-7010	B-06	670D2016	B-06	92171-7008	C-03		
11022-0710	B-03	16154-7011	B-06	92004-0723	B-10	92172-0792	B-09		
11022-0711	B-03	16171-7022	B-09	92009-2083	B-10	92172-7018	B-08		
11055-7009	B-05	16186-7006	B-10	92009-2303	B-08	92173-1000	C-03		
11060-7016	B-11	172BA06115	B-10	92009-2303	B-11	92173-1001	B-11		
11061-7009	B-10	172BA0818	B-03	92009-2303	C-03	92173-7003	B-11		
11061-7010	B-10	21039-7002	C-04	92009-2308	B-08	92173-7010	B-11		
11061-7083	B-03	21066-7017	B-08	92009-2349	B-10	92192-7146	B-11		
11061-7086	B-11	21080-0005	C-04	92009-2402	B-10	92192-7148	C-03		
11061-7087	B-10	21163-0727	C-04	92015-1367	B-11	92192-7165	B-11		
11061-7088	B-10	21171-0711	B-08	92026-7007	B-07	92192-7172	C-03		
11061-7093	B-10	21188-7002	B-10	92033-0727	B-05	92192-7188	C-03		
11061-7094	B-03	21193-7038	B-08	92033-7018	B-04	92200-0848	B-10		
12004-0705	B-05	214AA0408	B-03	92039-7004	B-07	92200-2151	B-05		
12005-0720	B-05	214AA0408	B-09	92043-1263	B-03	92200-7002	B-08		
12009-7001	B-05	23062-7024	B-07	92049-7001	B-03	92200-7009	B-05		
12011-2056	B-05	26011-7025	B-08	92049-7010	B-03	92200-7023	C-04		
12016-2066	B-05	26031-7040	B-08	92049-7019	B-03	92200-7024	C-04		
12032-7001	B-05	26031-7041	B-08	92049-7028	B-03	92200-7048	B-05		
13001-7027	B-04	27012-7008	C-04	92063-7141	B-10	92210-7027	B-11		
13002-0704	B-04	311AA0600	B-09	92063-7142	B-10				
13008-7005	B-04	312AA0500	B-09	92063-7149	B-10				
13025-7009	B-04	312AA0600	B-05	92066-0095	B-11				
13029-7010	B-04	32154-7019	B-03	92066-0761	B-03				
13031-0747	B-04	32155-7003	B-03	92066-0762	B-03				
13070-7017	B-05	39074-7001	B-10	92066-0762	B-08				
130AA0620	B-08	39129-7028	B-09	92066-7003	B-06				
130AA0625	B-03	39184-0020	C-04	92066-7032	B-10				
130AA0630	B-10	411AA0600	B-09	92070-7004	B-08				
130AA0814	B-05	42036-7015	C-03	92072-7003	B-08				
130BA0840	C-04	42036-7021	B-05	92081-2234	B-10				
130CA1050	B-03	42036-7022	B-11	92093-0593	B-10				
130CA1065	B-03	461DA0800	B-11	92104-7001	B-03				
13101-7010	C-04	49015-7106	B-03	92140-7003	B-06				
13107-7018	B-10	49019-0014	C-03	92140-7005	B-05				
13107-7047	B-09	49040-7008	C-03	92145-2122	B-10				
13116-7007	B-05	49065-7006	B-06	92145-7001	B-05				
13251-7025	B-04	49065-7007	B-06	92145-7002	B-06				
13271-7007	B-05	49078-7002	B-05	92145-7057	B-09				
13271-7021	B-05	49089-7079	B-07	92145-7058	B-09				
13271-7038	B-09	49089-7080	B-07	92150-2182	B-09				
13272-1374	B-03	49103-7014	B-09	92151-7012	B-07				
13272-7006	B-07	49103-7015	B-09	92151-7017	B-04				
13272-7011	B-06	49113-0727	B-09	92152-1689	B-05				
13272-7012	B-08	49118-7022	B-05	92153-0009	B-09				
14037-7008-9H	B-07	49120-0733	B-03	92153-7007	B-07				
14075-7013	B-06	49121-7018	B-10	92153-7008	B-06				
14091-7064	B-03	510A5100	B-08	92153-7033	B-09				
15004-0828	B-10	55020-0900	B-07	92153-7034	C-04				
16014-7010	B-10	555A0420	B-06	92153-7043	B-03				
16020-7003	B-10	56033-7001	D-03	92153-7043	B-06				
16025-7017	B-10	56071-0216	D-03	92153-7043	B-07				
16030-7003	B-10	56080-0750	D-03	92153-7043	B-09				
16031-7002	B-10	59031-7017	B-08	92153-7054	B-03				
16041-0007	B-10	59041-7014	B-07	92153-7100	B-05				
16041-7051	B-10	59066-0014	B-07	92154-7003	B-08				