

Kawasaki

— ENGINES —

PARTS CATALOG

4-STROKE AIR-COOLED GASOLINE ENGINE

PRODUCT CODE
FR651V-FS05
FR651V-GS05

PARTS CATALOG INTRODUCTION

This parts catalog lists parts and sub-assemblies provided as service parts. When it becomes necessary to replace parts, always use KAWASAKI GENUINE PARTS which have passed strict inspection which guarantees quality and performance.

1. HOW TO ORDER PARTS

- 1) When ordering the parts, be sure to use the parts catalog corresponding to the product code. Check the product revision codes on the product and the catalog.

Product Code (example) : FA130D-AA00
 Product Revision Code

- 2) Specify the part code (all digits) exactly as listed in this catalog on your parts order.
- 3) The parts not shown in the illustrations of this catalog are not sold separately; only the complete units or next higher assemblies illustrated are supplied as the service parts.

2. EXPLANATION OF PARTS CATALOG FORMAT

Ref. No.	Part No.	Description	Quantity
14091	14091-2141	COVER	1
19073	19073-2241	INSULATOR	1
21169	21169-2077	TERMINAL	1
21171	21171-2267	COIL-ASSY-IGNITION	1
21194	21194-2355	FLYWHEEL-COMP	1
29011	29011-2390	WIRE-LEAD	1
92038	92038-2107	KEY	1
92070	92070-2119	PLUG-SPARK(BP/RSES(NGK))	1
92154	92154-2014	BOLT 4X18	1
92154A	92154-2018	BOLT 6X20	2
92154B	92154-2017	BOLT 12X30	1
92200	92200-2183	WASHER 4.5X8X0.5	1
92210	92210-2126	NUT M4	1

1) Product Code

This code describes the product code covered by this catalog. The product revision code, which is a part of the product code, is omitted.

2) Part Group Title

This title is the representative name for the group of parts illustrated on the page.

3) Reference Number

The reference numbers are shown on the illustration and the list as the link between them.

4) Part Number

This is the key of your parts ordering. Three kinds of part number are used in this catalog.

a. Structure 1

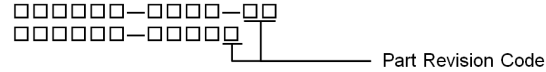

b. Structure 2

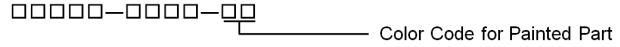

c. Standard Hardware Number

(for bolts, nuts, washer, or the like)



5) Description and Additional Information

The part name, the location, the size, and the serial number as additional information, etc. are described here. Use them to find out and check the part required. When a part number is changed without change of the product revision code and the changed parts are not interchangeable, the serial number of the product is noted as follows;

- (- FA130 - 100001) Affected units are from beginning of the product of the product code up to and including this serial number.
- (FA130 - 100002 -) Affected units are from this serial number and above.
- (FA130 - 100002 - FA130 - 110001) Affected units are in this serial number range.

6) Quantity

The figure shows quantity of the part required at the indicated position on the illustration and for the specified product revision code. The asterisk (*) on this column means the part can be used as the substitute on the product and is supplied until the stock is exhausted.

Note: Some small parts will be supplied by units.

Example: If six (6) bolts are ordered and the minimum quantity per unit is five (5), two (2), units of the bolt will be delivered.

7) Product Revision Code

This Code indicates an important change which affects the service parts interchangeability.

3. ABBREVIATIONS

#	Number	FR	Front	RH	Right Hand
&	And	G	Gram	RPM	Revolutions Per Minute
(+)	Plus	HEX	Hexagonal	RR	Rear
(-)	Minus	ID =	Inside Diameter	STD	Standard
2ND	Second	IN	Inch	T	Teeth
3RD	Third	L =	Length	T =	Thickness
4TH	Fourth	LH	Left Hand	U/S	Under Size
A	Ampere	LWR	Lower	UPP	Upper
AR	As Required	MM	Millimeter	V	Volt
ASSY	Assembly	O/S	Over Size	W	Watt
CNT	Center	OD =	Outside Diameter		
COMP	Complete	REF	Reference		

E0110-B016K

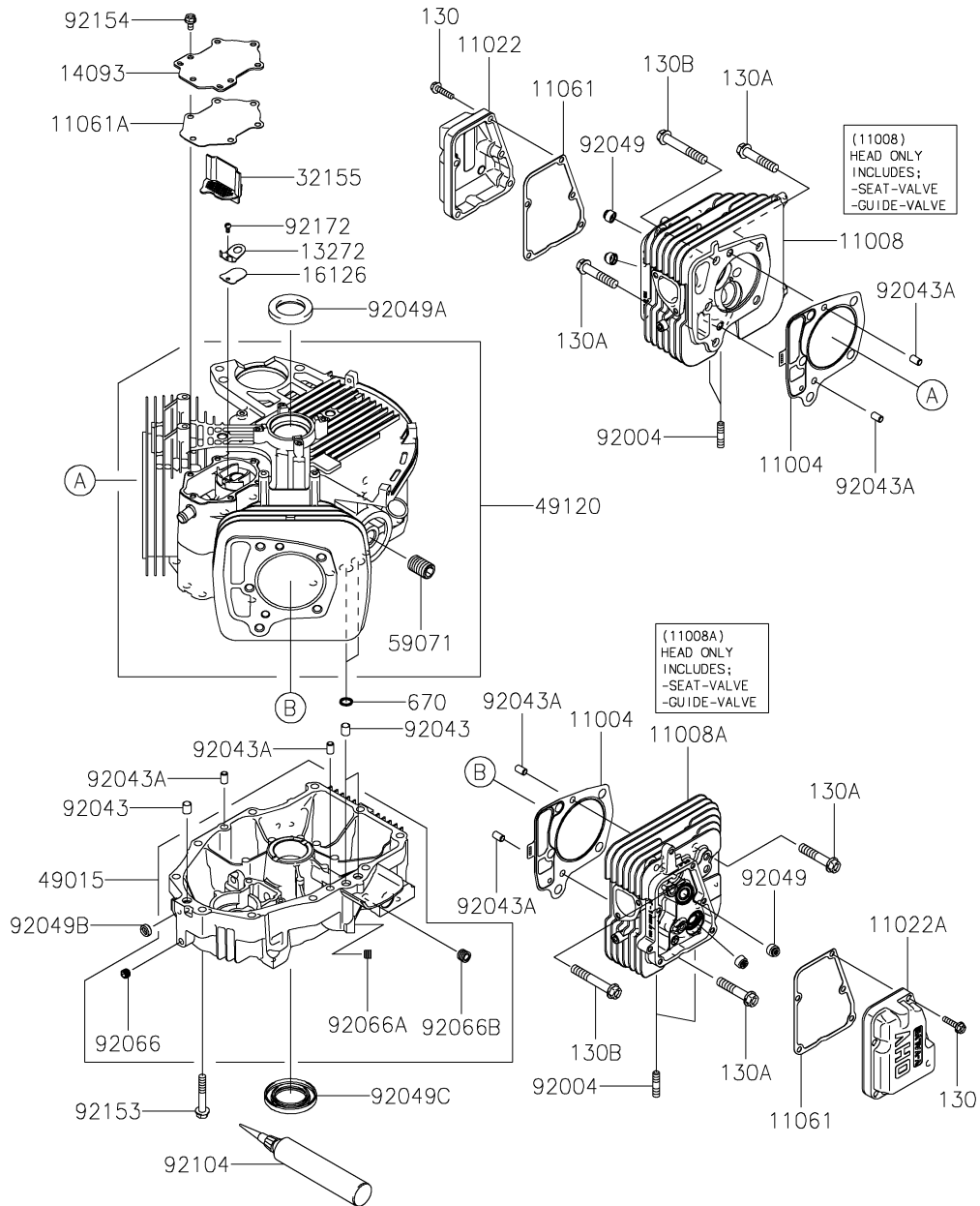

1. CYLINDER/CRANKCASE

Ref. No.	Part No.	Description	Quantity	
			FS05	GS05
11004	11004-0762	GASKET-HEAD	2	2
11008	11008-0986	HEAD-COMP-CYLINDER,#1	1	1
11008A	11008-0987	HEAD-COMP-CYLINDER,#2	1	1
11022	11022-0046	CASE-ROCKER,#1CYL	1	1
11022A	11022-0047	CASE-ROCKER,#2CYL	1	1
11061	11061-1285	GASKET,CASE-ROCKER	2	2
11061A	11061-7094	GASKET,BREATHER	1	1
13272	13272-1374	PLATE	1	1
14093	14093-0455	COVER,BREATHER	1	1
16126	16126-7020	VALVE,BREATHER	1	1
32155	32155-2214	PIPE,BREATHER	1	1
49015	49015-0023	COVER-CRANKCASE	1	1
49120	49120-0935	CRANKCASE-COMP	1	1
59071	59071-0743	JOINT,OIL FILTER	1	1
92004	92004-0815	STUD,8X30	4	4
92043	92043-0858	PIN	3	3
92043A	92043-1263	PIN,6.2X8X14	6	6
92049	92049-7001	SEAL-OIL,RVC2 6X11X10.2	4	4
92049A	92049-7010	SEAL-OIL,SD 35X48X8 R HS	1	1
92049B	92049-7019	SEAL-OIL,SO 8X14X5 HS	1	1
92049C	92049-7028	SEAL-OIL,38X62X8MTCLV	1	1
92066	92066-0880	PLUG,OIL	1	1
92066A	92066-0881	PLUG	1	1
92066B	92066-2223	PLUG	1	1
92104	92104-0007	GASKET-LIQUID,TB1217H	AR	AR
92153	92153-7054	BOLT,8X50	10	10
92154	92154-2938	BOLT,6X12	6	6
92172	92172-0870	SCREW,4X8	1	1
130	130BA0625	BOLT-FLANGED,6X25	10	10
130A	130CA1050	BOLT-FLANGED,10X50	4	4
130B	130CA1065	BOLT-FLANGED,10X65	6	6
670	670B2011	O RING,11MM	2	2

E0120-A574A

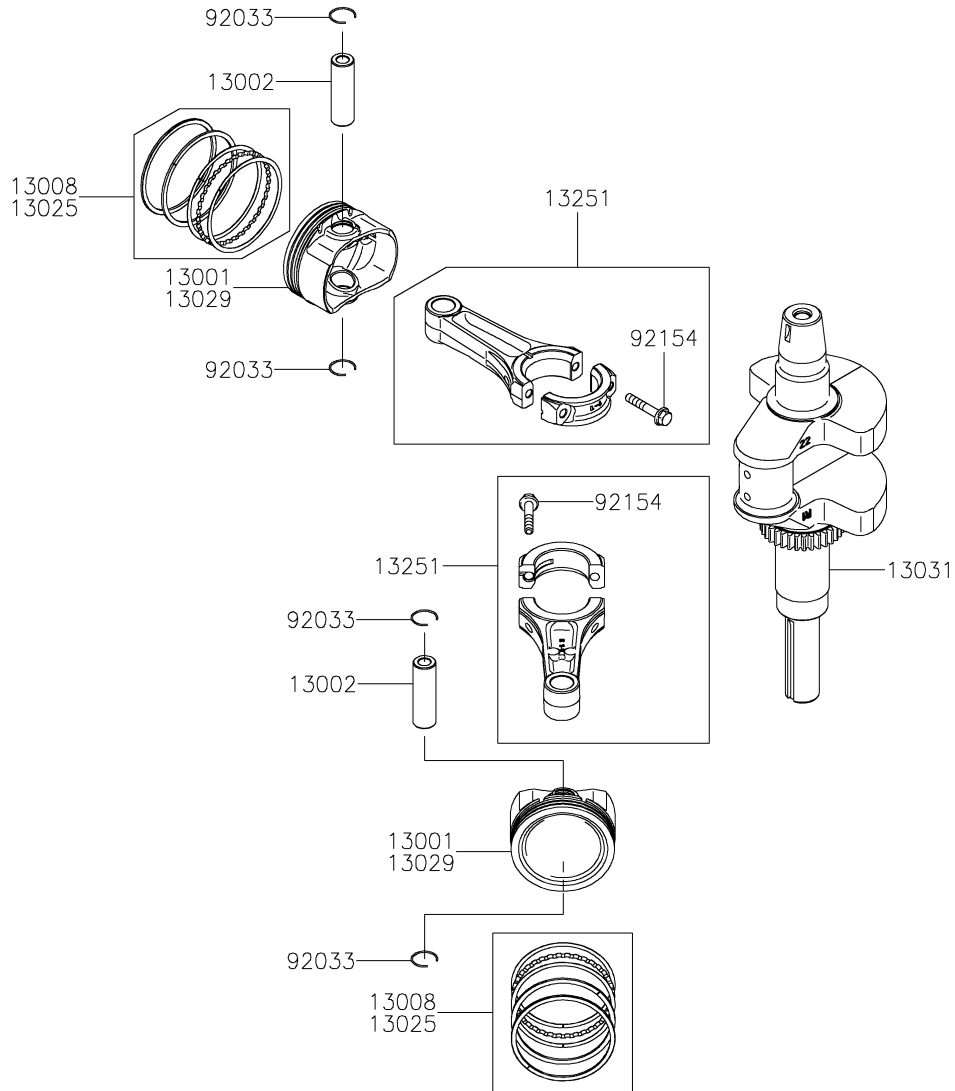

2. PISTON/CRANKSHAFT

Ref. No.	Part No.	Description	Quantity	
			FS05	GS05
13001	13001-0835	PISTON-ENGINE	2	2
13002	13002-0704	PIN-PISTON	2	2
13008	13008-0600	RING-SET-PISTON	2	2
13025	13025-0020	RING-SET-PISTON L,0.5	AR	AR
13029	13029-0045	PISTON-ENGINE L,0.5	AR	AR
13031	13031-0822	CRANKSHAFT-COMP	1	1
13251	13251-0719	ROD-ASSY-CONNECTING	2	2
92033	92033-0790	RING-SNAP	4	4
92154	92154-2842	BOLT,6X35	4	4

E0130-A248A

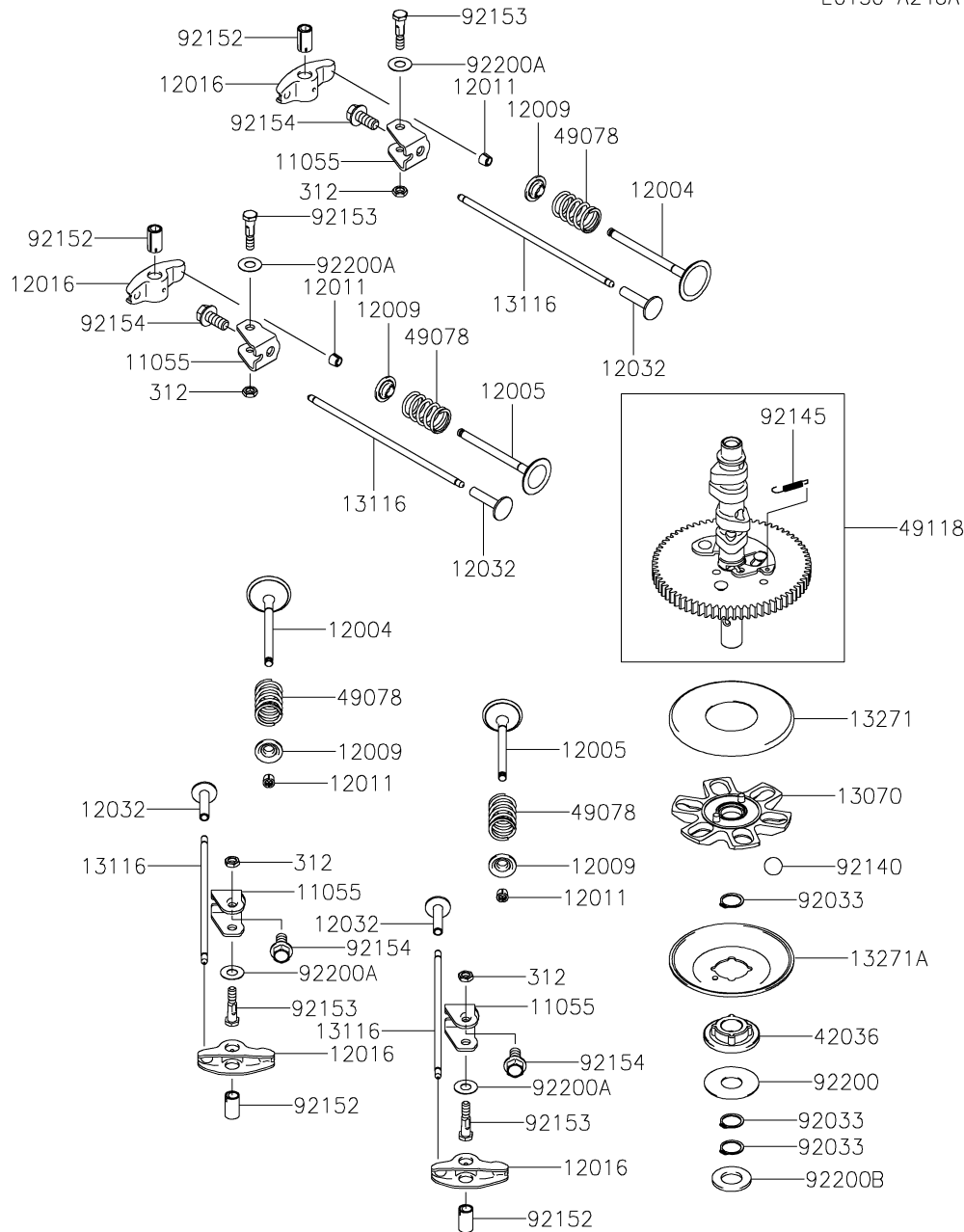

3. VALVE/CAMSHAFT

Ref. No.	Part No.	Description	Quantity	
			FS05	GS05
11055	11055-7009	BRACKET	4	4
12004	12004-0733	VALVE-INTAKE	2	2
12005	12005-0777	VALVE-EXHAUST	2	2
12009	12009-7001	RETAINER-VALVE SPRING	4	4
12011	12011-2056	COLLET	8	8
12016	12016-0040	ARM-ROCKER	4	4
12032	12032-7001	TAPPET	4	4
13070	13070-7017	GUIDE,GOVERNOR	1	1
13116	13116-0725	ROD-PUSH	4	4
13271	13271-7007	PLATE	1	1
13271A	13271-7021	PLATE,GOVERNOR	1	1
42036	42036-7021	SLEEVE	1	1
49078	49078-7002	SPRING-ENGINE VALVE,IN	4	4
49118	49118-1259	CAMSHAFT-COMP	1	1
92033	92033-0778	RING-SNAP	3	3
92140	92140-0026	BALL	6	6
92145	92145-1653	SPRING	1	1
92152	92152-1689	COLLAR	4	4
92153	92153-7100	BOLT,6X29.5	4	4
92154	92154-1267	BOLT,8X18.2	4	4
92200	92200-0945	WASHER,16X42X0.91	1	1
92200A	92200-2151	WASHER,8.1X18X0.5	4	4
92200B	92200-7048	WASHER,16.3X30X2.28	1	1
312	312AA0600	NUT-HEX,6MM	4	4

E0140-A672A

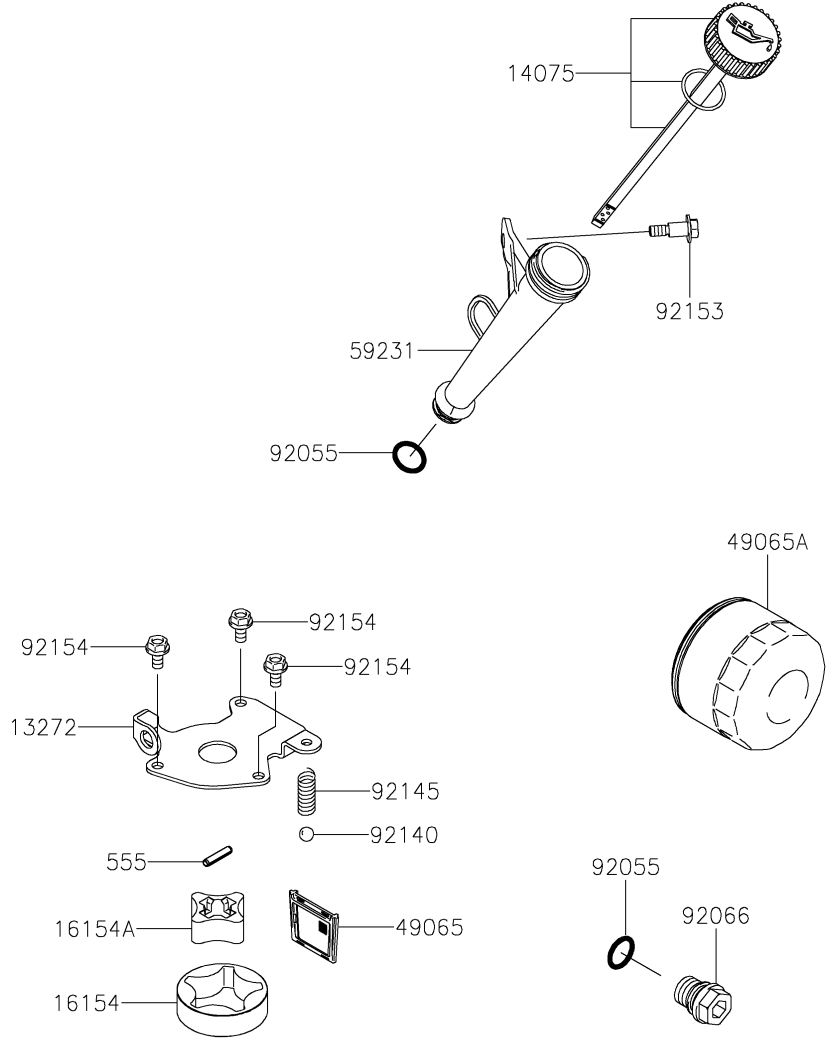

4. LUBRICATION-EQUIPMENT

Ref. No.	Part No.	Description	Quantity	
			FS05	GS05
13272	13272-7011	PLATE,ROTOR	1	1
14075	14075-0707	CAP-ASSY	1	1
16154	16154-7010	ROTOR-PUMP,OUTER	1	1
16154A	16154-7011	ROTOR-PUMP,INNER	1	1
49065	49065-0720	FILTER-OIL	1	1
49065A	49065-0721	FILTER-OIL	1	1
59231	59231-0778	FILLER	1	1
92055	92055-0892	RING-O,15.8X2.4	2	2
92066	92066-0774	PLUG	1	1
92140	92140-7003	BALL,STEEL,13/32	1	1
92145	92145-1809	SPRING,OIL RELIEF	1	1
92153	92153-7008	BOLT	1	1
92154	92154-2938	BOLT,6X12	3	3
555	555A0420	PIN-SPRING,4X20	1	1

E0150-B369B

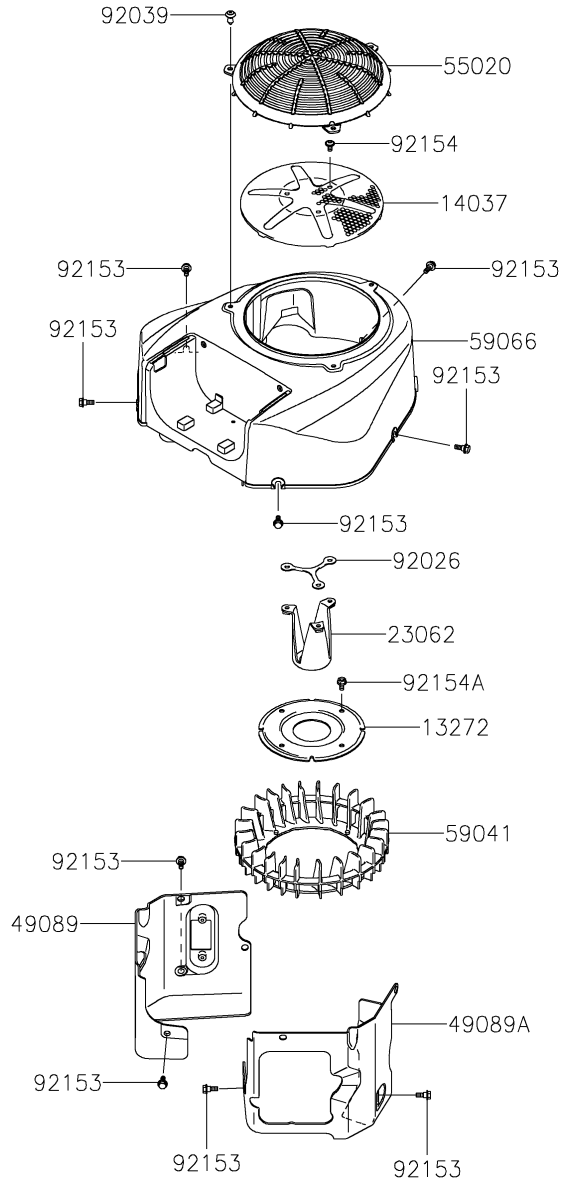

5. COOLING-EQUIPMENT

Ref. No.	Part No.	Description	Quantity	
			FS05	GS05
13272	13272-1487	PLATE,FAN	1	1
14037	14037-7008-9H	SCREEN	1	1
23062	23062-1276	BRACKET-COMP	1	1
49089	49089-7079	SHROUD-ENGINE	1	1
49089A	49089-7080	SHROUD-ENGINE	1	1
55020	55020-0900	GUARD	1	1
59041	59041-7014	FAN	1	1
59066	59066-0820	HOUSING-FAN	1	1
92026	92026-0866	SPACER	1	1
92039	92039-0751	RIVET, GUARD	3	3
92153	92153-7007	BOLT, FLANGED, 6X16	9	9
92154	92154-2687	BOLT, 6X12	3	3
92154A	92154-2938	BOLT, 6X12	4	4

E0160-B985A

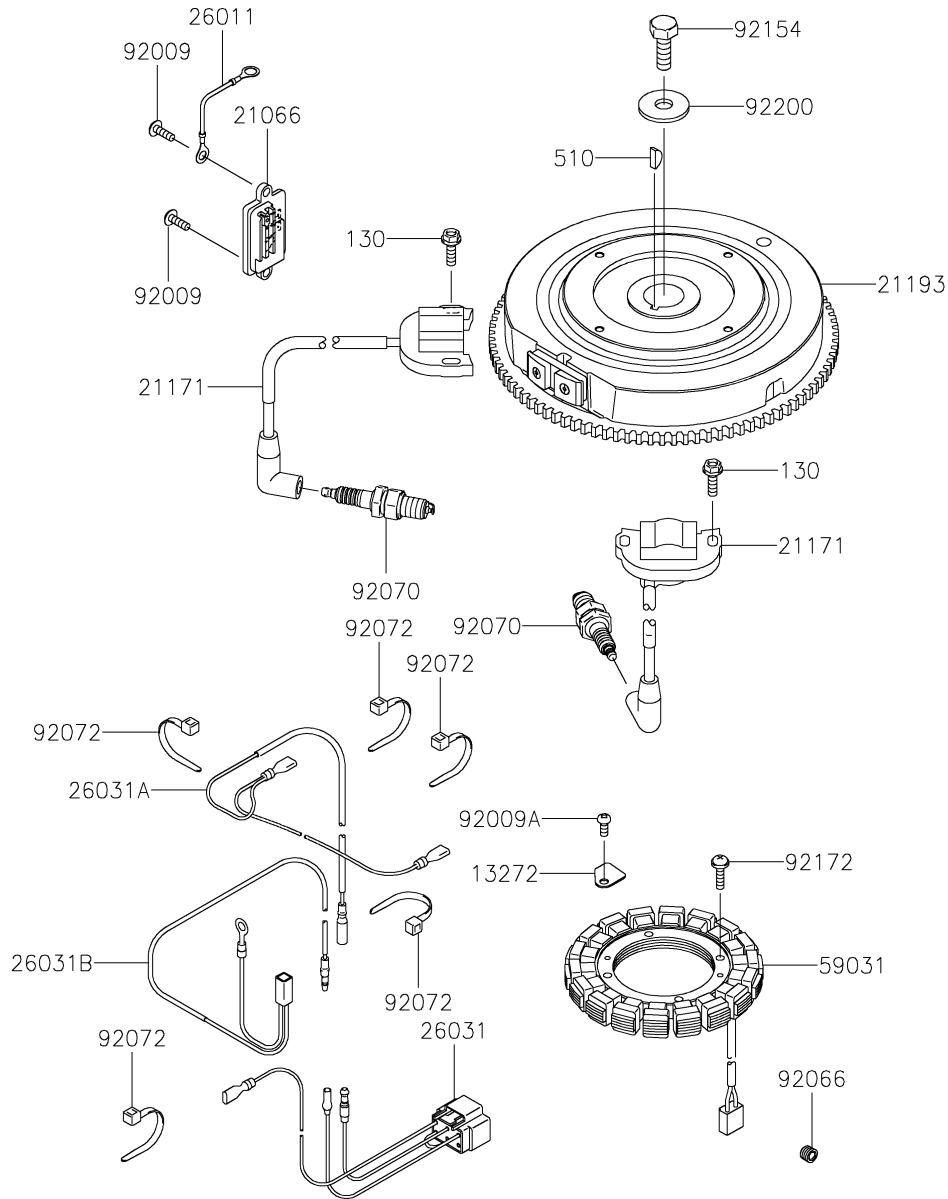

6. ELECTRIC-EQUIPMENT

Ref. No.	Part No.	Description	Quantity	
			FS05	GS05
13272	13272-7012	PLATE	1	1
21066	21066-7017	REGULATOR-VOLTAGE	1	1
21171	21171-0740	COIL-ASSY-IGNITION	2	2
21193	21193-0035	FLYWHEEL-ASSY	1	1
26011	26011-2234	WIRE-LEAD	1	1
26031	26031-1625	HARNESS	1	1
26031A	26031-7040	HARNESS	1	1
26031B	26031-7041	HARNESS	1	1
59031	59031-7017	COIL-CHARGING	1	1
92009	92009-2303	SCREW	2	2
92009A	92009-2308	SCREW	1	1
92066	92066-0881	PLUG	1	1
92070	92070-7004	PLUG-SPARK,BPR4ES(NGK),SOLID	2	2
92072	92072-7003	BAND	5	5
92154	92154-7003	BOLT,12X30	1	1
92172	92172-7018	SCREW,5X20	4	4
92200	92200-7002	WASHER	1	1
130	130BA0620	BOLT-FLANGED,6X20	4	4
510	510A5100	KEY-WOODRUFF	1	1

E0170-A882A

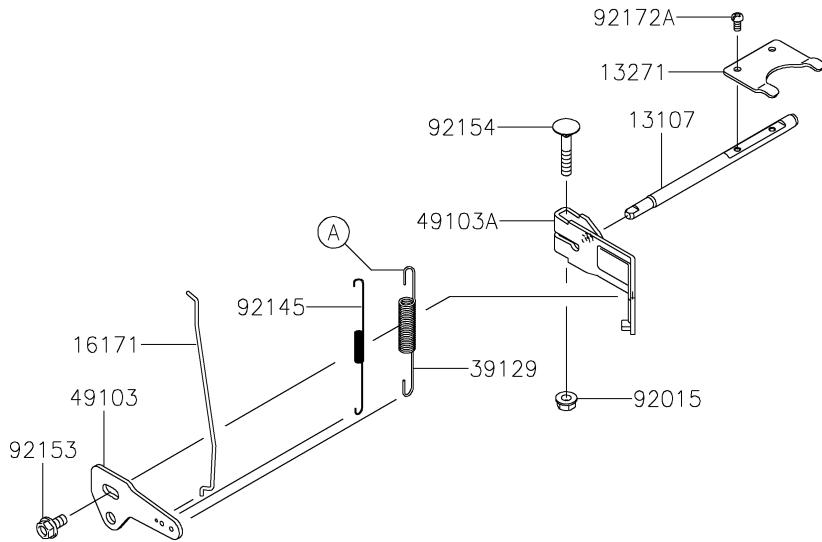
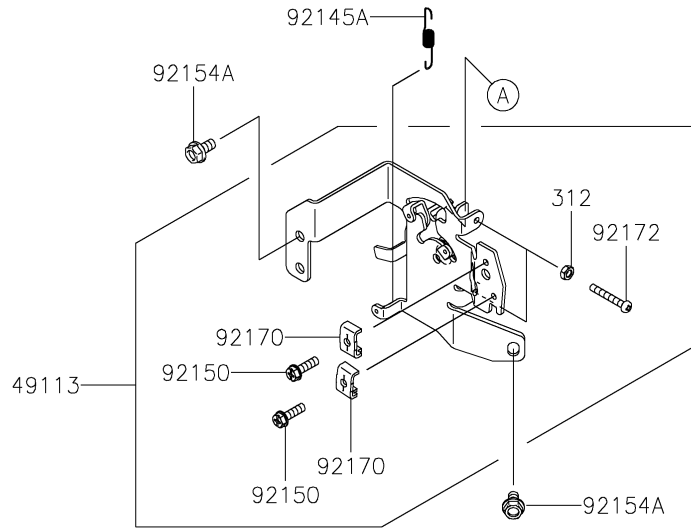

7. CONTROL-EQUIPMENT

Ref. No.	Part No.	Description	Quantity	
			FS05	GS05
13107	13107-7047	SHAFT,GOVERNOR	1	1
13271	13271-7038	PLATE	1	1
16171	16171-0042	LINK	1	1
39129	39129-0043	SPRING-GOVERNOR	1	1
49103	49103-0010	ARM-GOVERNOR	1	1
49103A	49103-7014	ARM-GOVERNOR	1	1
49113	49113-0727	PANEL-COMP-CONTROL	1	1
92015	92015-1367	NUT,FLANGED,6MM	1	1
92145	92145-1811	SPRING,LINK	1	1
92145A	92145-1812	SPRING	1	1
92150	92150-2182	BOLT,5X18	2	2
92153	92153-0009	BOLT,6X12	1	1
92154	92154-2697	BOLT,6X35	1	1
92154A	92154-2938	BOLT,6X12	2	2
92170	92170-7001	CLAMP	2	2
92172	92172-0792	SCREW,5X35	2	2
92172A	92172-0870	SCREW,4X8	2	2
312	312AA0500	NUT-HEX,5MM	2	2

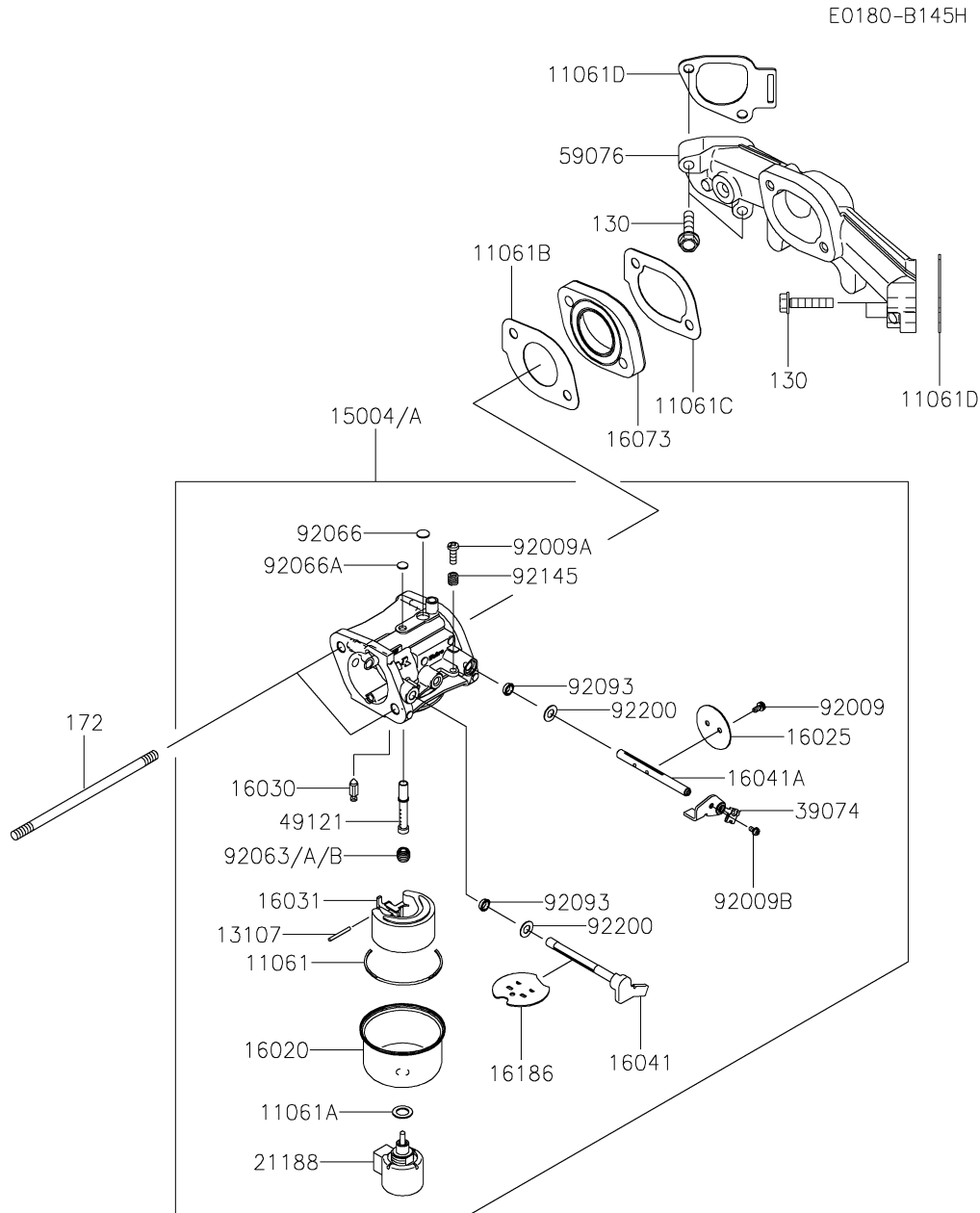

8. CARBURETOR

Ref. No.	Part No.	Description	Quantity	
			FS05	GS05
11061	11061-7009	GASKET,CHAMBER	1	1
11061A	11061-7010	GASKET,SCREW	1	1
11061B	11061-7087	GASKET,INSULATOR	1	1
11061C	11061-7088	GASKET,INSULATOR/MANIFOLD	1	1
11061D	11061-7093	GASKET,MANIFOLD	2	2
13107	13107-7018	SHAFT	1	1
15004	15004-1064	CARBURETOR-ASSY	1	
15004A	15004-1099	CARBURETOR-ASSY		1
16020	16020-7003	CHAMBER-FLOAT	1	1
16025	16025-7017	VALVE-THROTTLE	1	1
16030	16030-7003	VALVE-FLOAT	1	1
16031	16031-7002	FLOAT	1	1
16041	16041-0007	SHAFT-CARBURETOR,CHOKE	1	1
16041A	16041-7051	SHAFT-CARBURETOR,THROTTLE	1	1
16073	16073-7013	INSULATOR	1	1
16186	16186-7006	VALVE-ASSY-CHOKE	1	1
21188	21188-7002	SOLENOID	1	1
39074	39074-7001	LEVER-ASSY-THROTTLE	1	1
49121	49121-7018	NOZZLE-MAIN	1	1
59076	59076-0009	MANIFOLD-INTAKE	1	1
92009	92009-2083	SCREW	2	2
92009A	92009-2349	SCREW	1	1
92009B	92009-2402	SCREW	1	1
92063	92063-7141	JET-MAIN,#122 (OPTION)	1	1
92063A	92063-7142	JET-MAIN,#124	1	1
92063B	92063-7149	JET-MAIN,#120 (OPTION)	1	1
92066	92066-2204	PLUG	1	1
92066A	92066-2244	PLUG	1	1
92093	92093-0593	SEAL	2	2
92145	92145-1579	SPRING	1	1
92200	92200-0848	WASHER	2	2
130	130BA0630	BOLT-FLANGED,6X30	4	4
172	172BA06120	BOLT-STUD,6X120	2	2

E0190-B822C

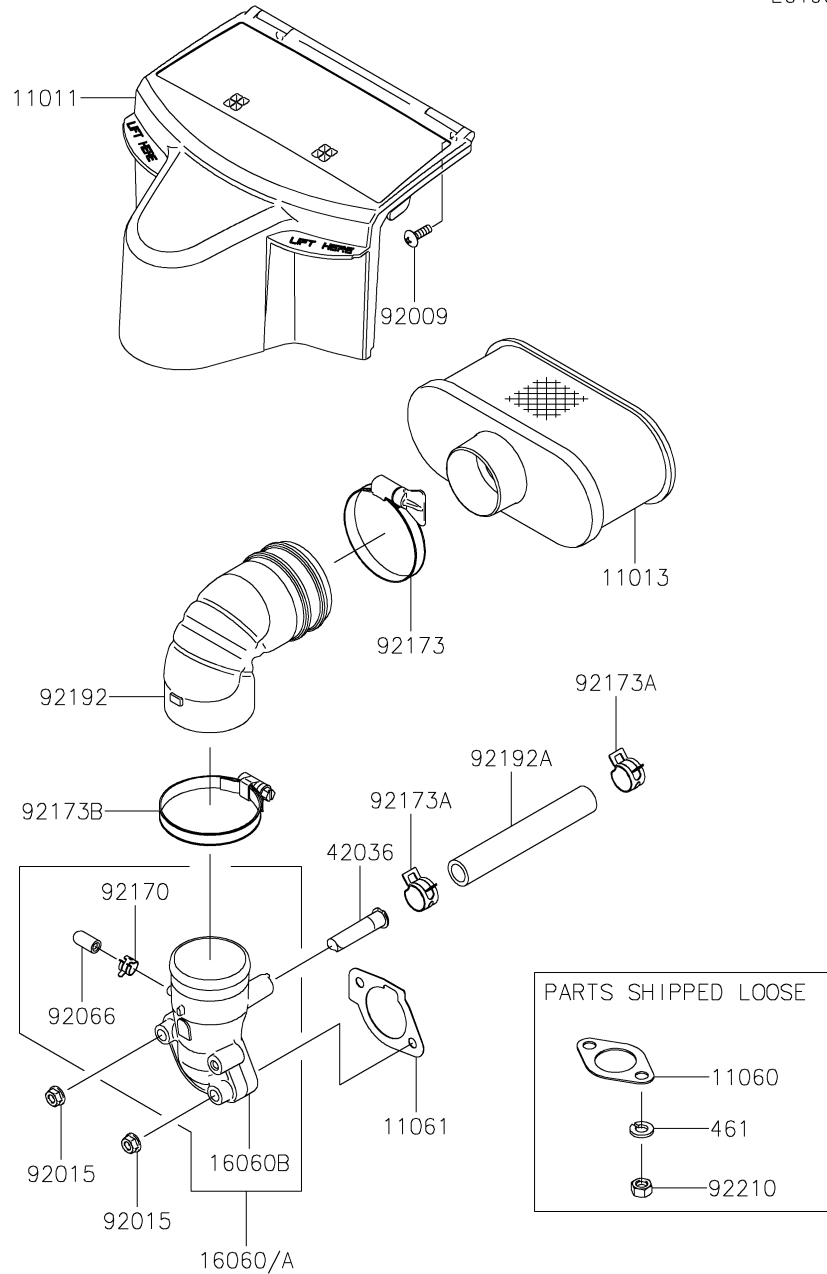

9. AIR-FILTER/MUFFLER

Ref. No.	Part No.	Description	Quantity	
			FS05	GS05
11011	11011-0820	CASE-AIR FILTER	1	1
11013	11013-0752	ELEMENT-AIR FILTER	1	1
11060	11060-7016	GASKET,MUFFLER	2	2
11061	11061-7086	GASKET,CARBURETOR/PIPE-INTAKE	1	1
16060	16060-0048	PIPE-INTAKE	1	
16060A	16060-0776	PIPE-INTAKE		1
16060B	16060-0777	PIPE-INTAKE	1	1
42036	42036-0781	SLEEVE,BREATHER	1	1
92009	92009-2303	SCREW	2	2
92015	92015-1367	NUT,FLANGED,6MM	2	2
92066	92066-0095	PLUG	1	1
92170	92170-2042	CLAMP	1	1
92173	92173-1001	CLAMP	1	1
92173A	92173-7003	CLAMP	2	2
92173B	92173-7010	CLAMP	1	1
92192	92192-2764	TUBE	1	1
92192A	92192-7146	TUBE,12.6X18.6X118	1	1
92210	92210-7027	NUT,M8	4	4
461	461DA0800	WASHER-SPRING,8MM	4	4

E0200-B108A

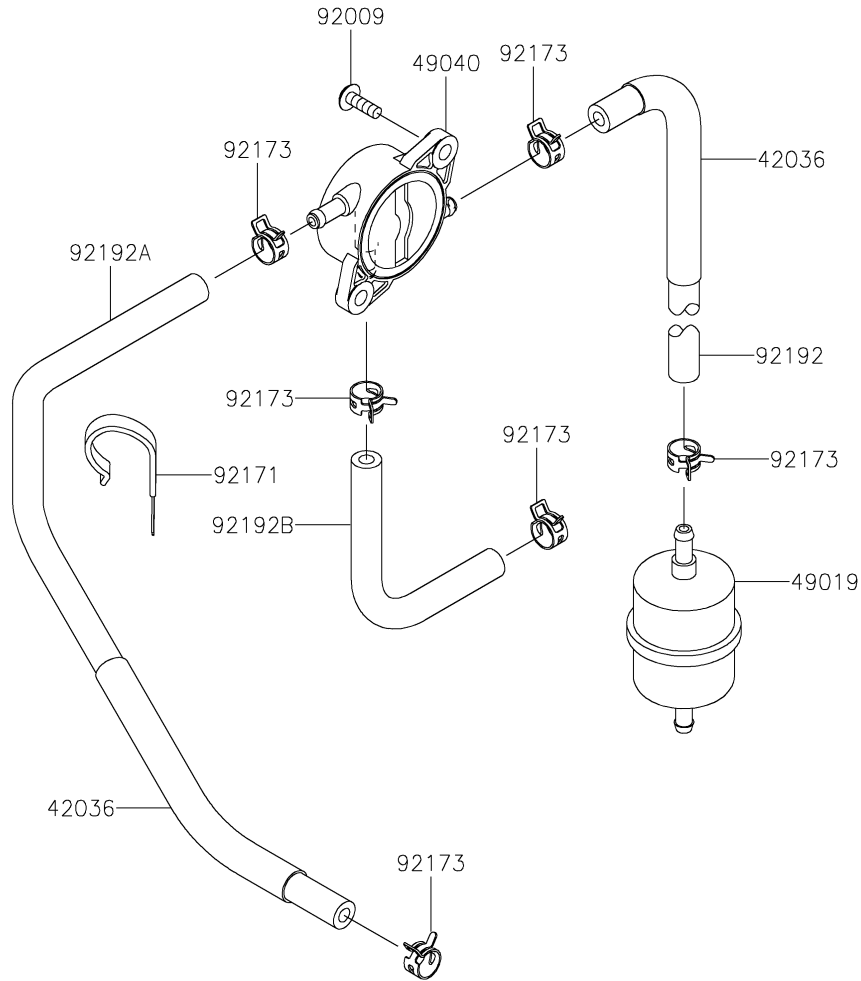

10. FUEL-TANK/FUEL-VALVE

Ref. No.	Part No.	Description	Quantity	
			FS05	GS05
42036	42036-7015	SLEEVE	2	2
49019	49019-0031	FILTER-FUEL	1	1
49040	49040-0802	PUMP-FUEL	1	1
92009	92009-2303	SCREW	2	2
92171	92171-7005	CLAMP	1	1
92173	92173-1582	CLAMP,11.8MM	6	6
92192	92192-2388	TUBE,6.35X12.7X185	1	1
92192A	92192-2392	TUBE,6.35X12.7X390	1	1
92192B	92192-7148	TUBE,6.4X12.7X150	1	1

E0210-A725A

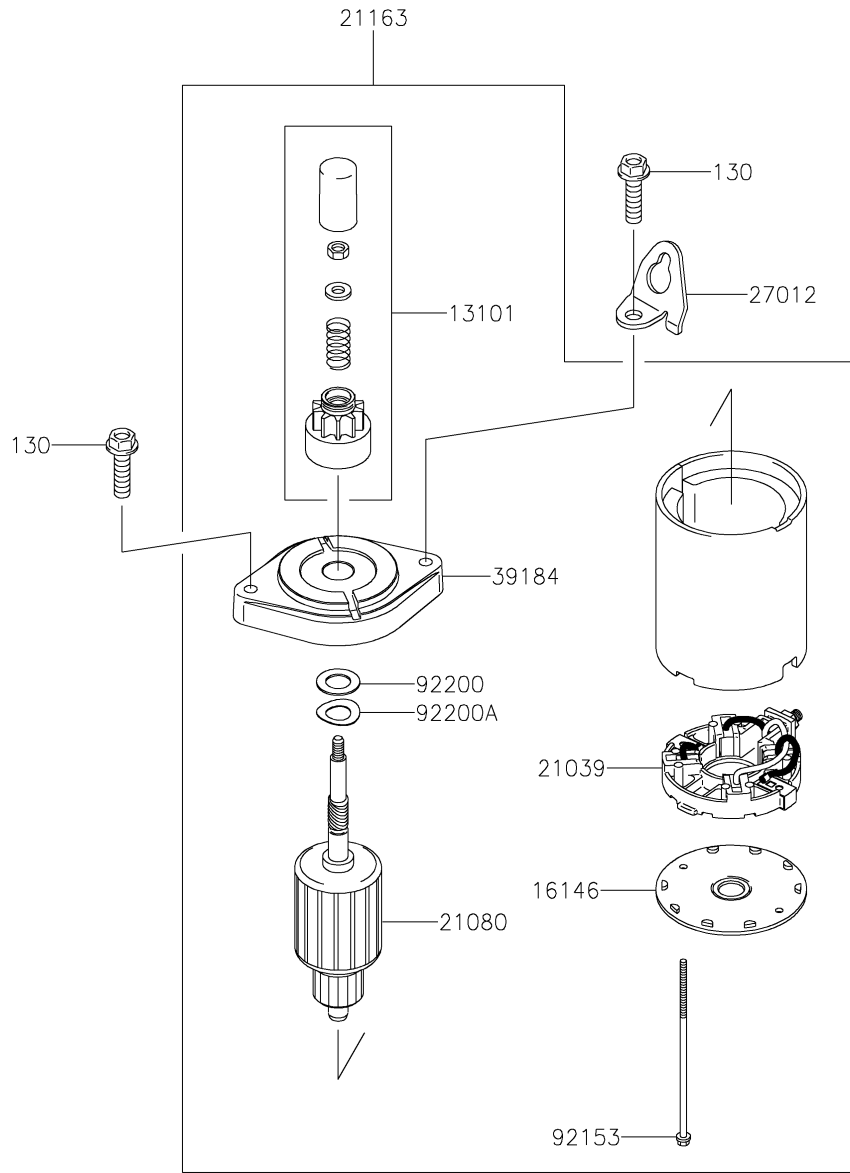

11. STARTER

Ref. No.	Part No.	Description	Quantity	
			FS05	GS05
13101	13101-0650	GEAR-ASSY	1	1
16146	16146-7013	COVER-ASSY	1	1
21039	21039-7002	BRUSH	1	1
21080	21080-0009	ARMATURE	1	1
21163	21163-0804	STARTER-ELECTRIC	1	1
27012	27012-7008	HOOK	1	1
39184	39184-0019	BRACKET-ASSY	1	1
92153	92153-7034	BOLT	2	2
92200	92200-7023	WASHER	1	1
92200A	92200-7024	WASHER	1	1
130	130BA0840	BOLT-FLANGED,8X40	2	2

FR651V- FS05/GS05

F0290-C213A

12. LABEL

Ref. No.	Part No.	Description	Quantity	
			FS05	GS05
56033	56033-7001	LABEL-MANUAL	1	1
56071	56071-0216	LABEL-WARNING	1	1
56080	56080-0914	LABEL-BRAND,FR651V WITH HP	1	1

56033

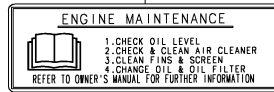

56071



56080



FR651V- FS05/GS05

NUMERICAL PARTS INDEX

Part No.	Fig No.	Part No.	Fig No.	Part No.	Fig No.	Part No.	Fig No.	Part No.	Fig No.	Part No.	Fig No.
11004-0762	1	14093-0455	1	49089-7080	5	92066-2223	1	92200-7023	11		
11008-0986	1	15004-1064	8	49103-0010	7	92066-2244	8	92200-7024	11		
11008-0987	1	15004-1099	8	49103-7014	7	92070-7004	6	92200-7048	3		
11011-0820	9	16020-7003	8	49113-0727	7	92072-7003	6	92210-7027	9		
11013-0752	9	16025-7017	8	49118-1259	3	92093-0593	8				
11022-0046	1	16030-7003	8	49120-0935	1	92104-0007	1				
11022-0047	1	16031-7002	8	49121-7018	8	92140-0026	3				
11055-7009	3	16041-0007	8	510A5100	6	92140-7003	4				
11060-7016	9	16041-7051	8	55020-0900	5	92145-1579	8				
11061-1285	1	16060-0048	9	555A0420	4	92145-1653	3				
11061-7009	8	16060-0776	9	56033-7001	12	92145-1809	4				
11061-7010	8	16060-0777	9	56071-0216	12	92145-1811	7				
11061-7086	9	16073-7013	8	56080-0914	12	92145-1812	7				
11061-7087	8	16126-7020	1	59031-7017	6	92150-2182	7				
11061-7088	8	16146-7013	11	59041-7014	5	92152-1689	3				
11061-7093	8	16154-7010	4	59066-0820	5	92153-0009	7				
11061-7094	1	16154-7011	4	59071-0743	1	92153-7007	5				
12004-0733	3	16171-0042	7	59076-0009	8	92153-7008	4				
12005-0777	3	16186-7006	8	59231-0778	4	92153-7034	11				
12009-7001	3	172BA06120	8	670B2011	1	92153-7054	1				
12011-2056	3	21039-7002	11	92004-0815	1	92153-7100	3				
12016-0040	3	21066-7017	6	92009-2083	8	92154-1267	3				
12032-7001	3	21080-0009	11	92009-2303	10	92154-2687	5				
13001-0835	2	21163-0804	11	92009-2303	6	92154-2697	7				
13002-0704	2	21171-0740	6	92009-2303	9	92154-2842	2				
13008-0600	2	21188-7002	8	92009-2308	6	92154-2938	1				
13025-0020	2	21193-0035	6	92009-2349	8	92154-2938	4				
13029-0045	2	23062-1276	5	92009-2402	8	92154-2938	5				
13031-0822	2	26011-2234	6	92015-1367	7	92154-2938	7				
13070-7017	3	26031-1625	6	92015-1367	9	92154-7003	6				
130BA0620	6	26031-7040	6	92026-0866	5	92170-2042	9				
130BA0625	1	26031-7041	6	92033-0778	3	92170-7001	7				
130BA0630	8	27012-7008	11	92033-0790	2	92171-7005	10				
130BA0840	11	312AA0500	7	92039-0751	5	92172-0792	7				
130CA1050	1	312AA0600	3	92043-0858	1	92172-0870	1				
130CA1065	1	32155-2214	1	92043-1263	1	92172-0870	7				
13101-0650	11	39074-7001	8	92049-7001	1	92172-7018	6				
13107-7018	8	39129-0043	7	92049-7010	1	92173-1001	9				
13107-7047	7	39184-0019	11	92049-7019	1	92173-1582	10				
13116-0725	3	42036-0781	9	92049-7028	1	92173-7003	9				
13251-0719	2	42036-7015	10	92055-0892	4	92173-7010	9				
13271-7007	3	42036-7021	3	92063-7141	8	92192-2388	10				
13271-7021	3	461DA0800	9	92063-7142	8	92192-2392	10				
13271-7038	7	49015-0023	1	92063-7149	8	92192-2764	9				
13272-1374	1	49019-0031	10	92066-0095	9	92192-7146	9				
13272-1487	5	49040-0802	10	92066-0774	4	92192-7148	10				
13272-7011	4	49065-0720	4	92066-0880	1	92200-0848	8				
13272-7012	6	49065-0721	4	92066-0881	1	92200-0945	3				
14037-7008-9H	5	49078-7002	3	92066-0881	6	92200-2151	3				
14075-0707	4	49089-7079	5	92066-2204	8	92200-7002	6				

Kawasaki Motors, Ltd.

Part No. 99907-3227-02