

REV	DISCRIPTION	ECN	DATE	REV	ECN	DATE
A0	PRE-PRODUCTION RELEASE		11-6-97			
A1	PRODUCTION RELEASE		12-12-97			
A2	CHANGE U76 FROM 72-1423-01 TO 72-1423-06 INSTALL 6ohm JUMPER BETWEEN PINS 5 & 6 OF J1 AND J2	1959	1.6.98			
A3	UPDATE SOFTWARE TO V1.01. CHANGE V2 TO 12AX7MA (76-0003).	2003	2-5-98			
A4	UPDATE RIBBON CABLES TO KEYED VERSION TO AVOID CONFUSION.	2070	3-6-98			
A5	CHANGE EEPROM TO JM250 V1.02 (72-1423-06V1.02)	2100	3.19.98			
A6	CHANGE H5,7,9,11,18,19 TO 32-1083, H17 TO 32-2000	2217	5.13.98			
A7	CHANGE C4,8 FROM 60-0406 TO 60-0310	2287	6.11.98			
A8	CHANGE V1 TUBE FROM 76-0001 TO 76-0003	95	8.3.98			
A9	CHANGE U63 FROM 72-3181 TO 72-3178	142	9.3.98			
AA	EEPROM CHANGE FROM V1.03 TO V1.04	149	9.11.98			
AB	SOFTWARE CHANGE FROM V1.04 TO V1.05	166	9.24.98			
AC	CHANGE U63 FROM 72-3178 TO 72-3181	202	10.15.98			
AD	CHANGE U61 & 62 TO 54-0353, R390 TO 15K, R388 TO 750 OHM C239 TO 15U LL	255	11.19.98			
AE	ADD 1 EACH 10U TANT 62-0163 ACROSS C236 AND C247	314	1.14.99			
AF	CHANGE TUBES TO 76-0002	479	3.30.99			
AG	CHANGE U63 FROM 72-3178 TO 72-3181 (THIS ECN WAS SKIPPED)	310	3.31.99			
AH	CHANGE SDISC FROM 72-3180 TO 72-5500	620	6.21.99			
AI	REPLACE BATTERY 24-1016 AND HOLDER 24-1014 WITH BATTERY 24-1027					

LINK
055093AI.001
055093AI.002
055093AI.003
055093AI.004
055093AI.005
055093AI.006
055093AI.007
055093AI.008
055093AI.009
055093AI.010
055093AI.011
055093AI.012
055093AI.013
055093AI.014

Digitech		
8760 South Sandy Parkway Sandy, Utah 84070		
Title JM-250 Main Board 80-6295		
Size B	Document Number 055093AI.000	Rev AI
Date: Tuesday, July 11, 2000	Sheet 0 of 14	

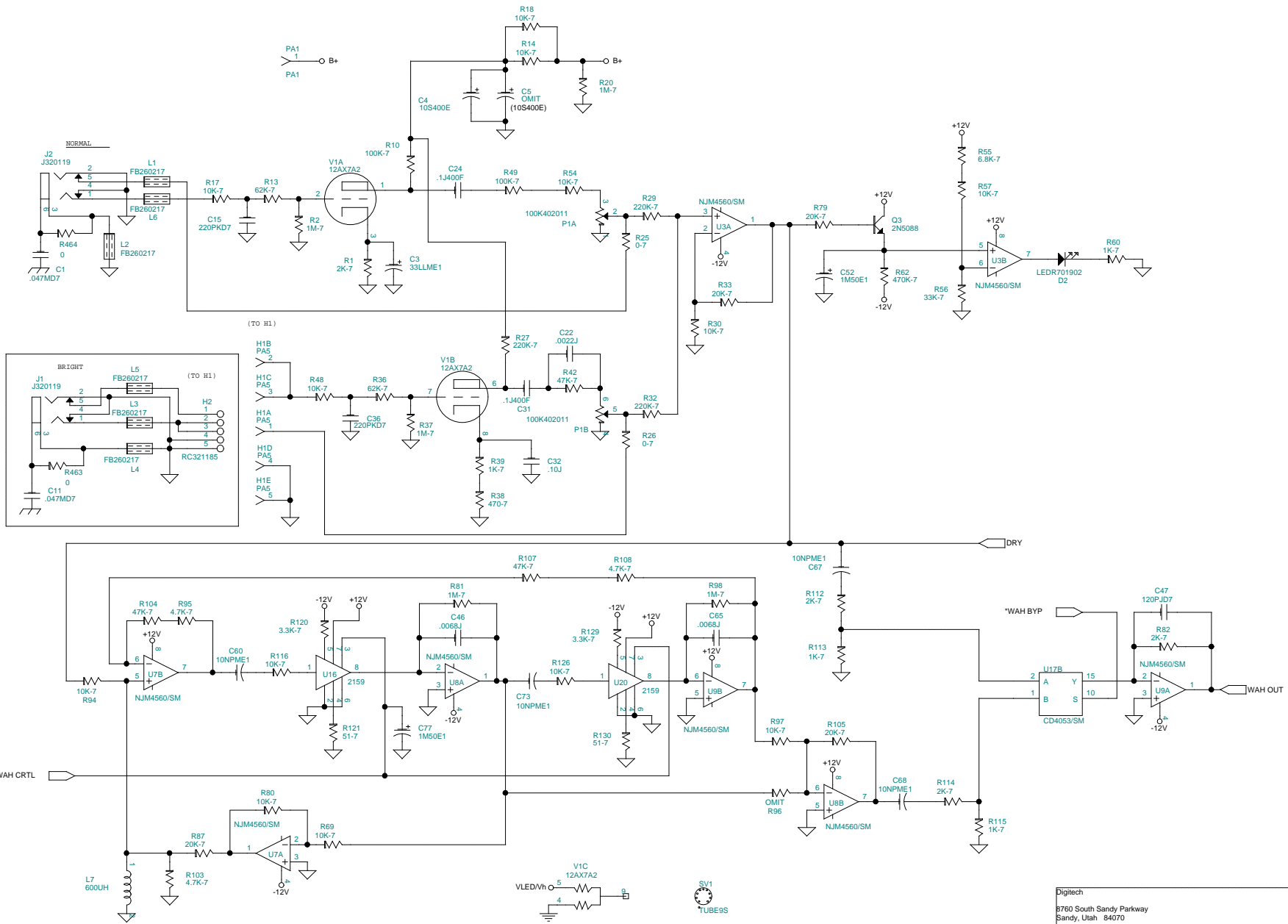

Digitech	
8760 South Sandy Parkway Sandy, Utah 84070	
Title	
JM-250 Main Board 80-6295	
Size	Document Number
B	055093AI.001
Date:	Rev
Tuesday, July 11, 2000	A1
Sheet	1 of 14

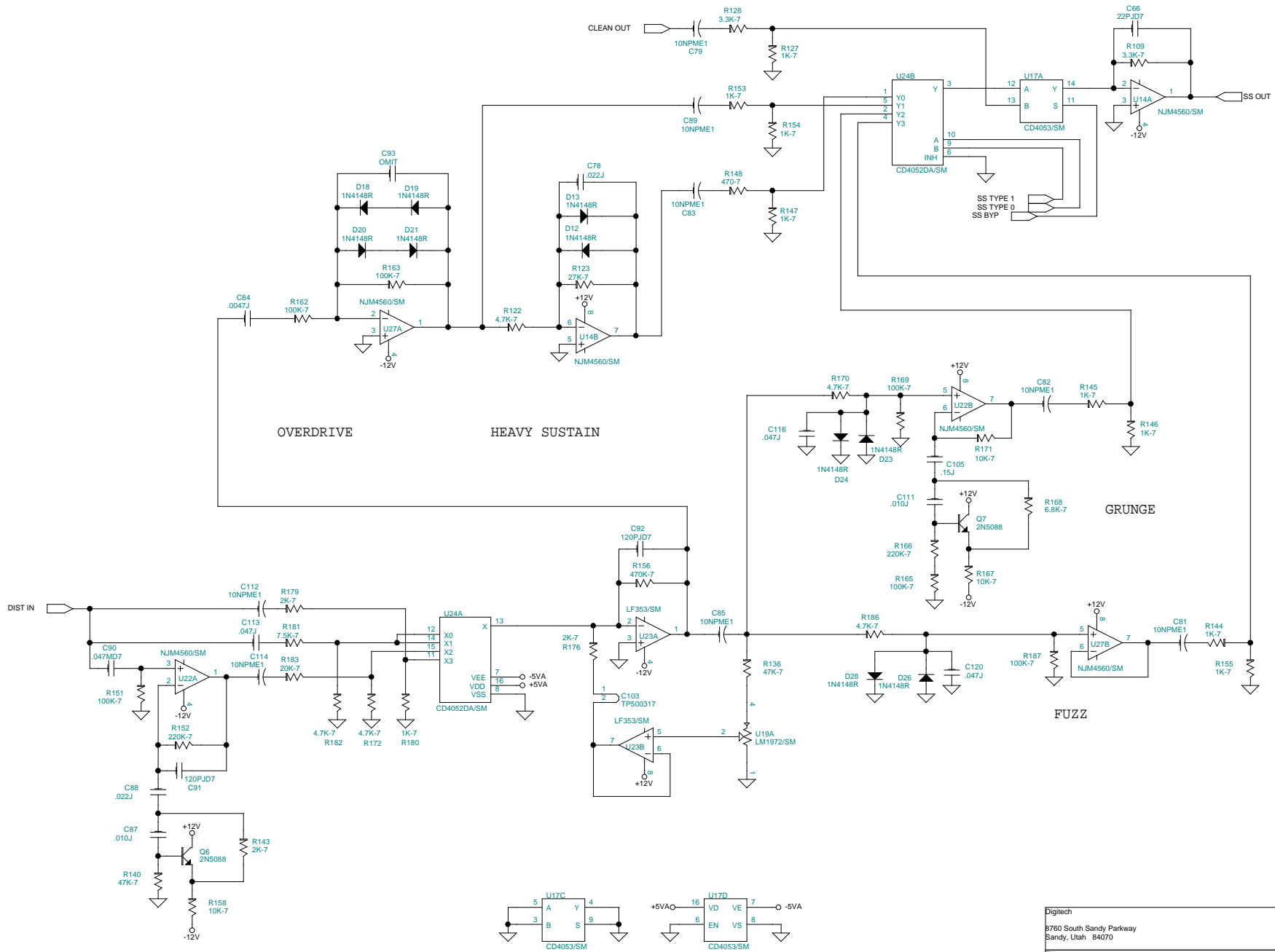

Digitech	
8760 South Sandy Parkway Sandy, Utah 84070	
Title	
JM-250 Main Board 80-6295	
Size	Document Number
B	055093AI.002
Date:	Rev
Tuesday, July 11, 2000	AI
Sheet	2 of 14

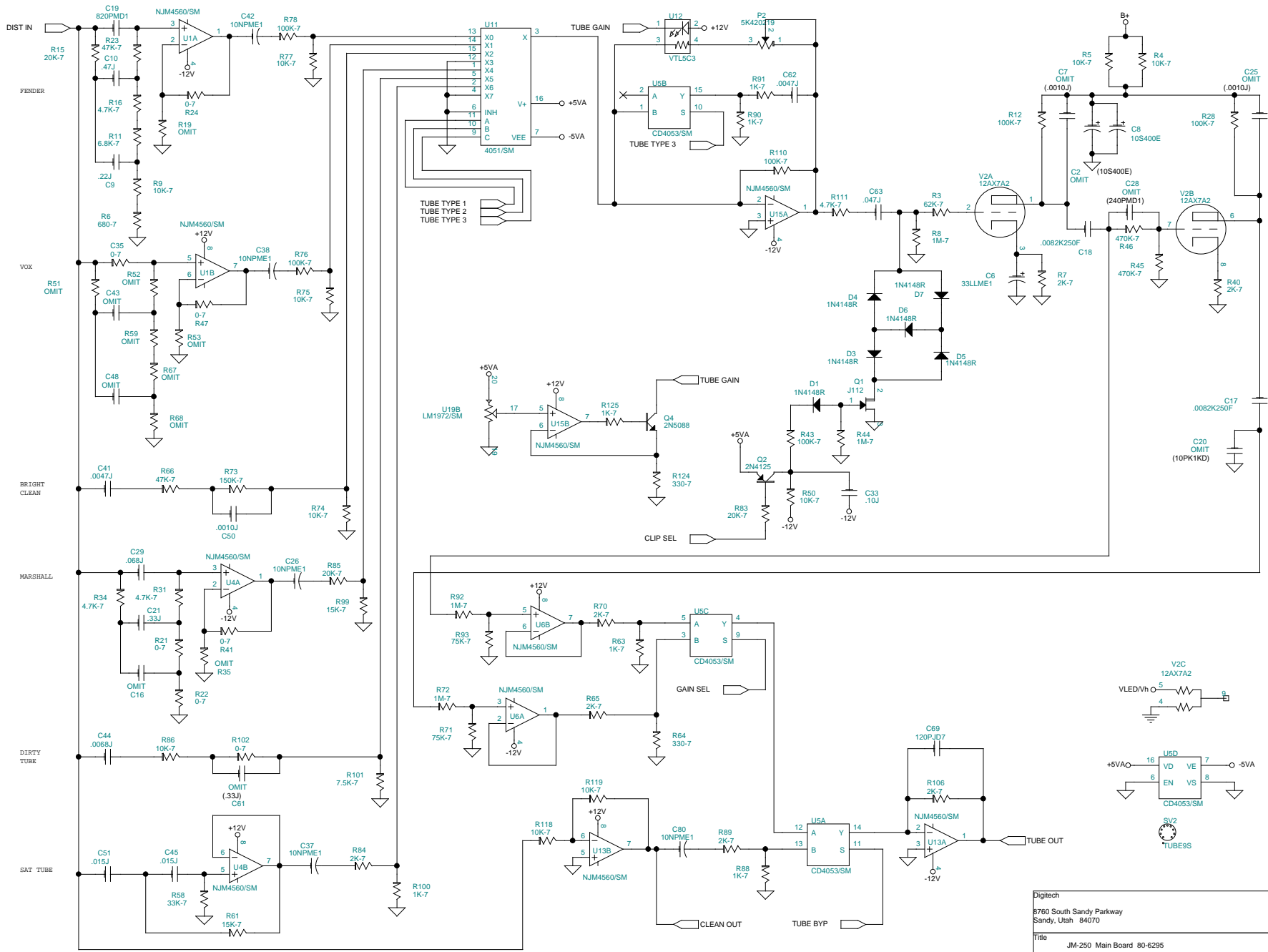

Digitech
 8760 South Sandy Parkway
 Sandy, Utah 84070
 Title
 JM-250 Main Board 80-6295
 Size B Document Number 055093AI.003 Rev AI
 Date: Tuesday, July 11, 2000 Sheet 3 of 14

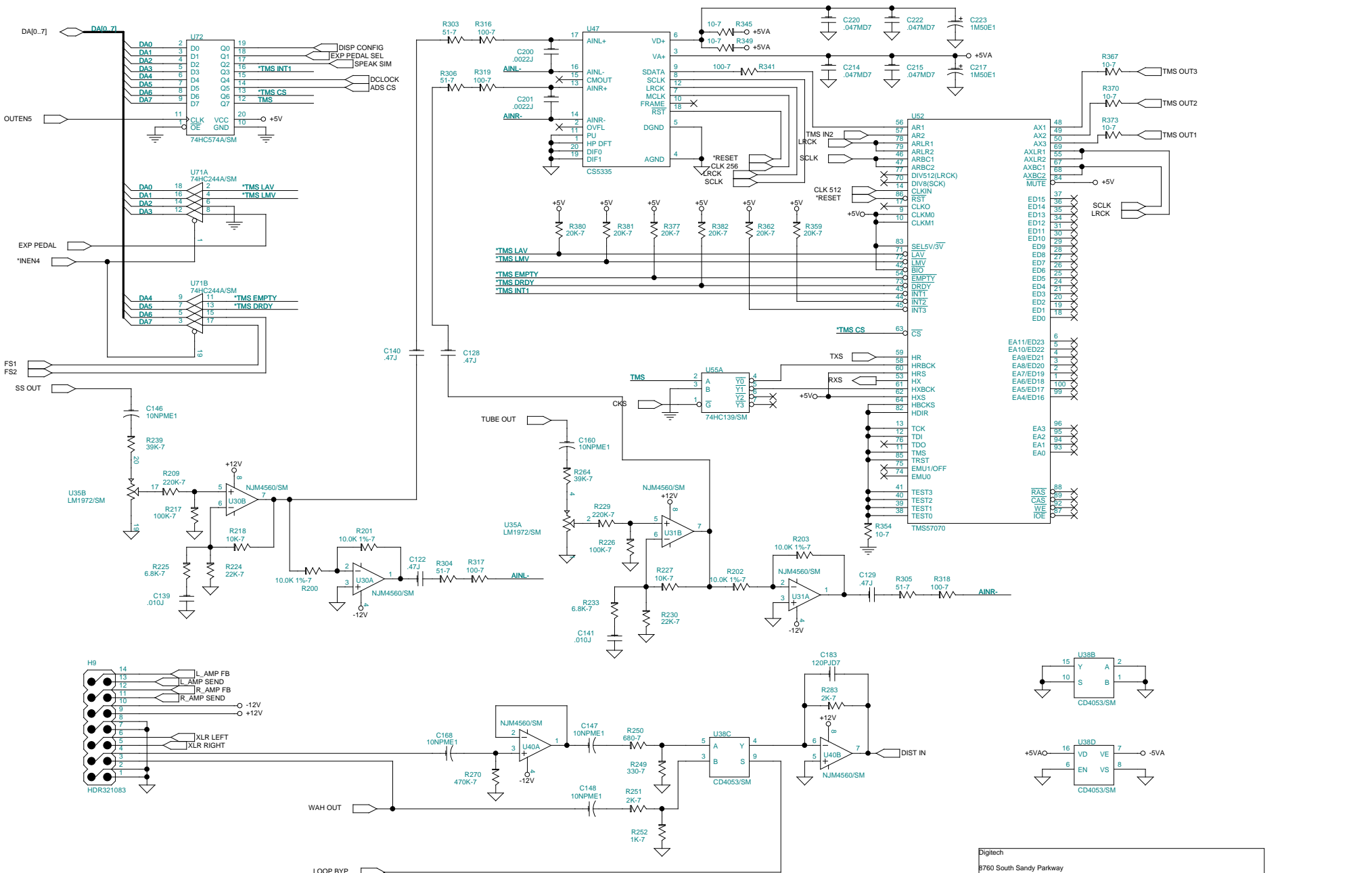

Digitech	
8760 South Sandy Parkway Sandy, Utah 84070	
Title	
JM-250 Main Board 80-6295	
Size B	Document Number 055093AI.004
Date:	Tuesday, July 11, 2000
Sheet	4 of 14
Rev	AI

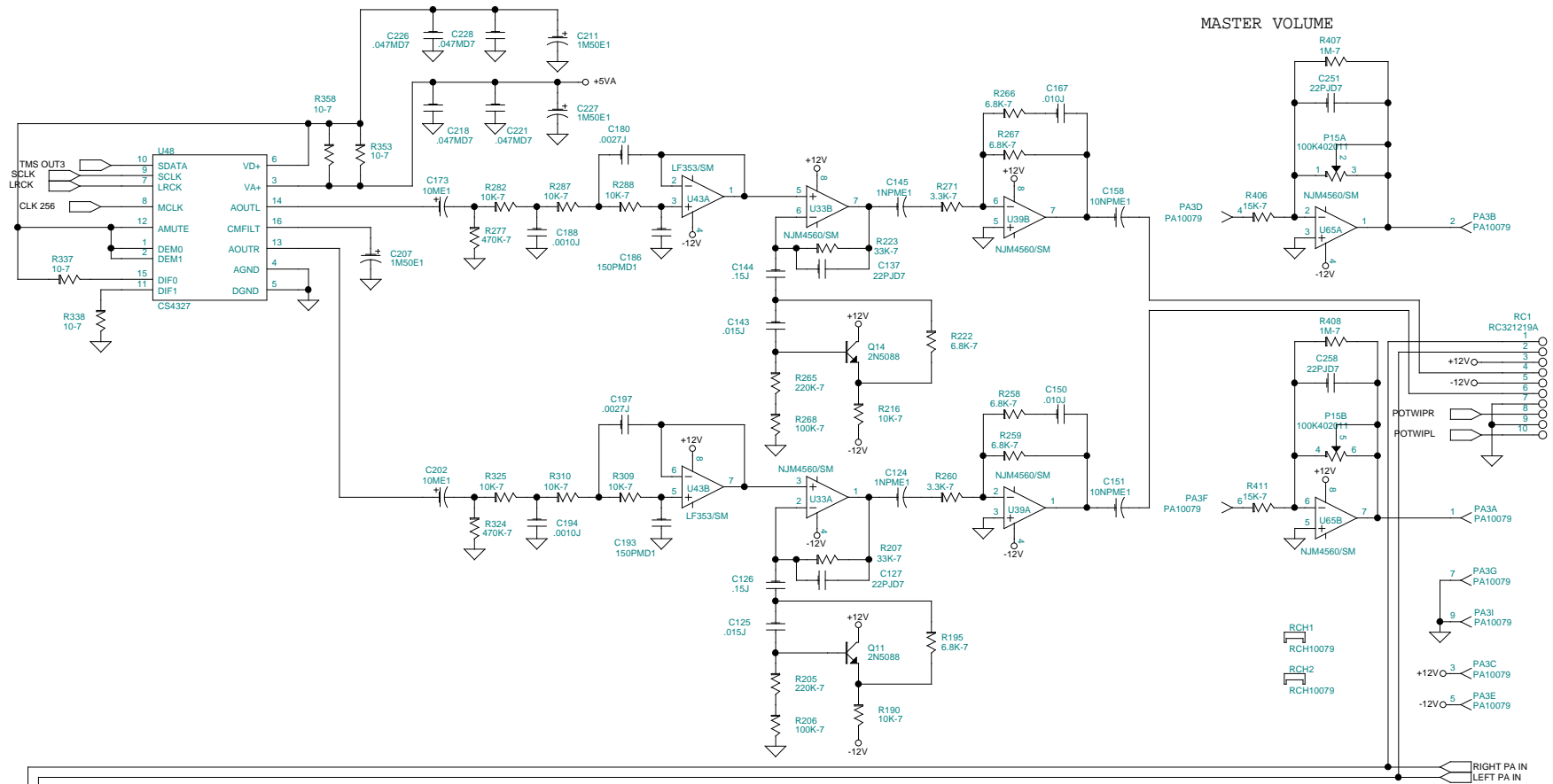

MASTER VOLUME

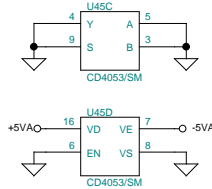
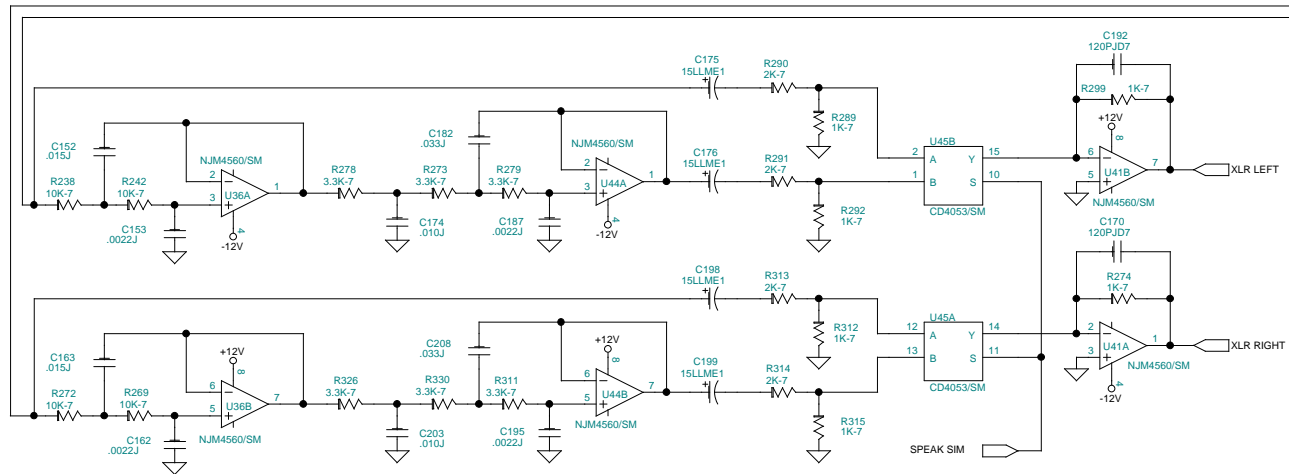
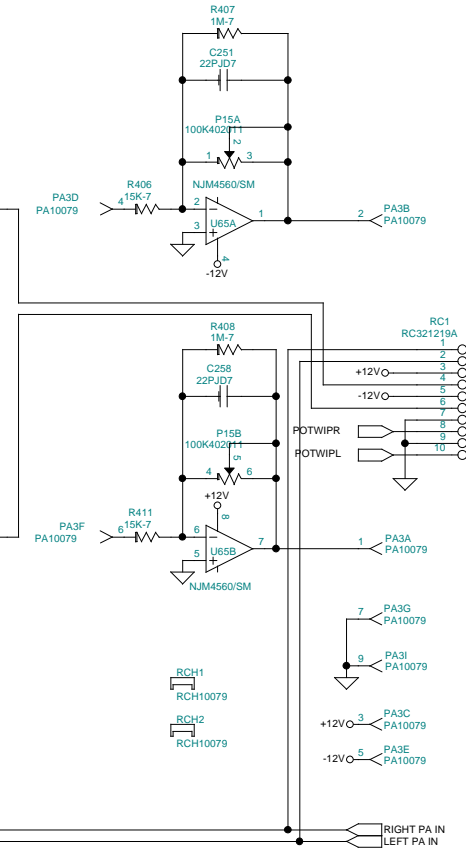

Digitech	
8760 South Sandy Parkway Sandy, Utah 84070	
Title JM-250 Main Board 80-6295	
Size B	Document Number 055093AI.005
Date: Tuesday, July 11, 2000	Rev A1
Sheet 5 of 14	

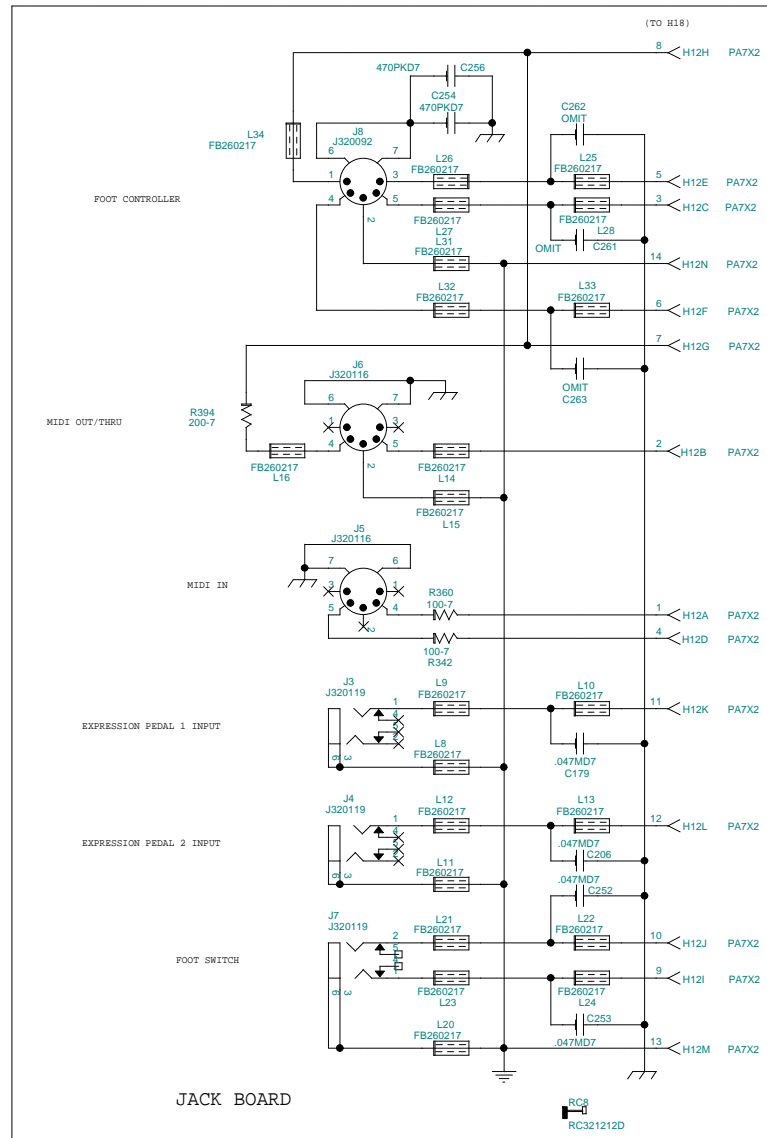
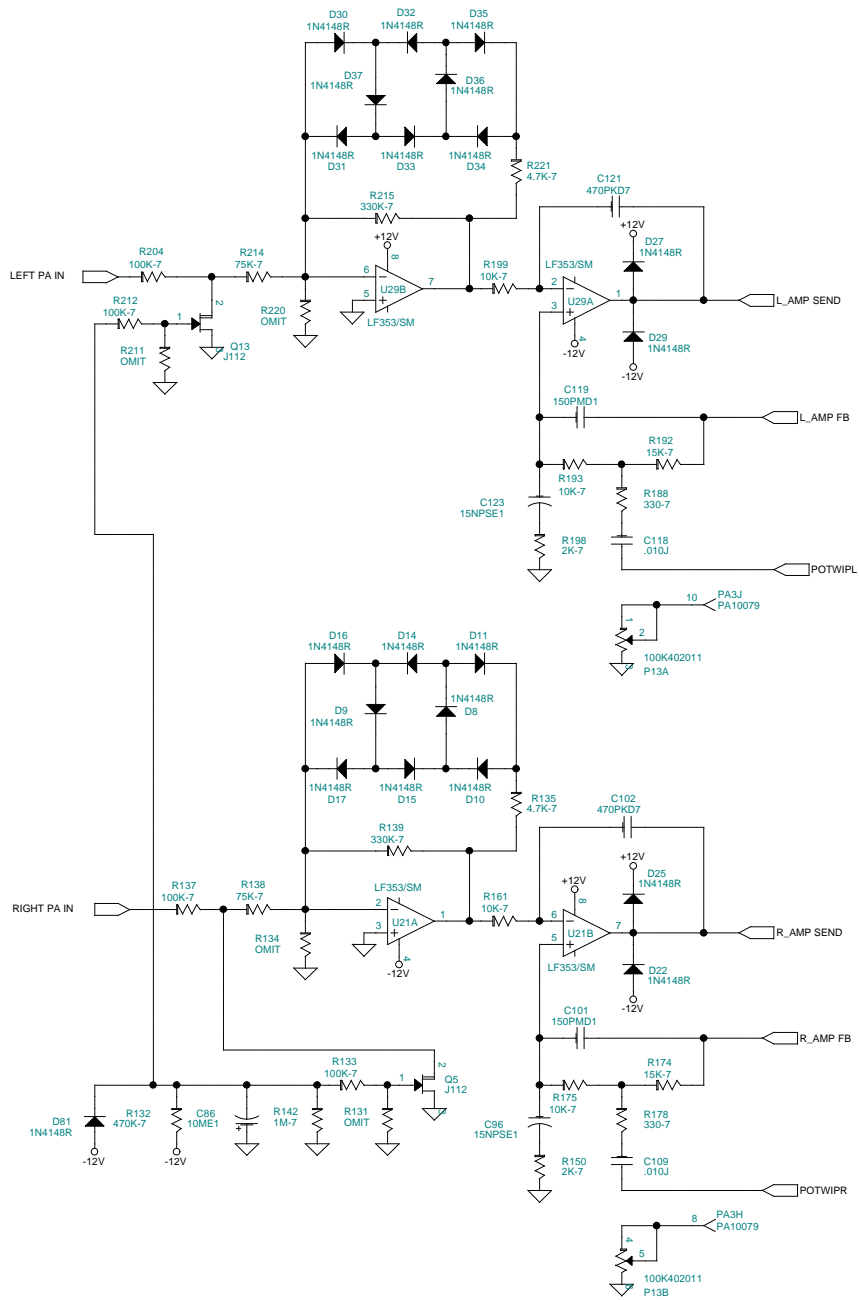

Digitech	
8760 South Sandy Parkway Sandy, Utah 84070	
Title JM-250 Main Board 80-6295	
Size B	Document Number 055093AI.006
Date: Tuesday, July 11, 2000	Rev A1
Sheet 6 of 14	

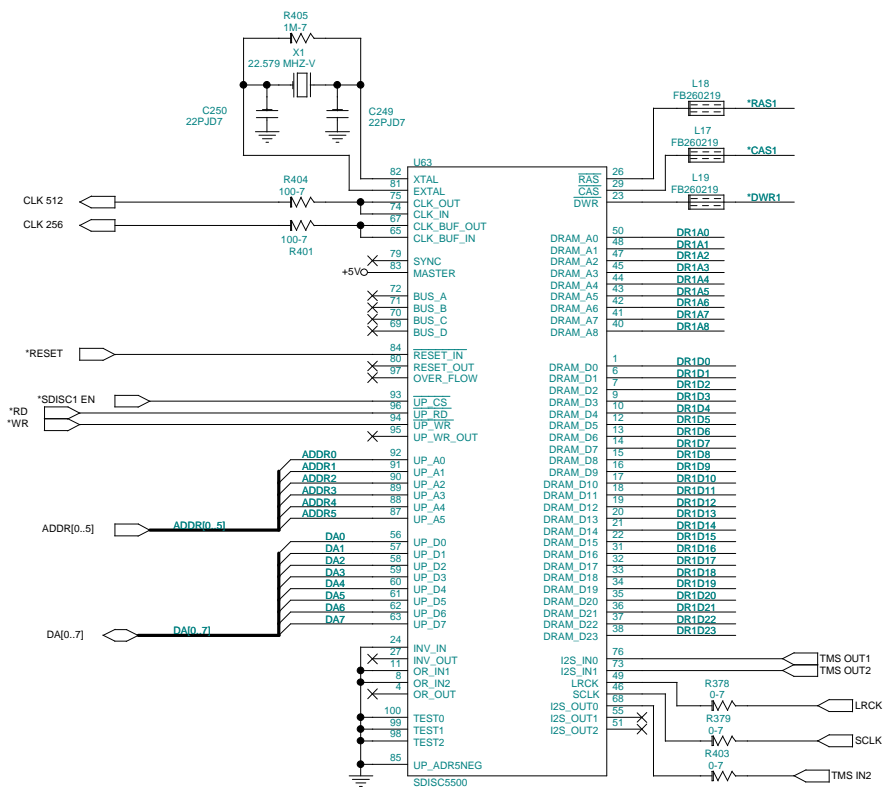

DRAM_A0	48	DR1A0
DRAM_A1	47	DR1A1
DRAM_A2	46	DR1A2
DRAM_A3	45	DR1A3
DRAM_A4	44	DR1A4
DRAM_A5	43	DR1A5
DRAM_A6	42	DR1A6
DRAM_A7	41	DR1A7
DRAM_A8	40	DR1A8
DRAM_D0	1	DR1D0
DRAM_D1	6	DR1D1
DRAM_D2	7	DR1D2
DRAM_D3	8	DR1D3
DRAM_D4	9	DR1D4
DRAM_D5	10	DR1D5
DRAM_D6	11	DR1D6
DRAM_D7	12	DR1D7
DRAM_D8	13	DR1D8
DRAM_D9	14	DR1D9
DRAM_D10	15	DR1D10
DRAM_D11	16	DR1D11
DRAM_D12	17	DR1D12
DRAM_D13	18	DR1D13
DRAM_D14	19	DR1D14
DRAM_D15	20	DR1D15
DRAM_D16	21	DR1D16
DRAM_D17	22	DR1D17
DRAM_D18	23	DR1D18
DRAM_D19	24	DR1D19
DRAM_D20	25	DR1D20
DRAM_D21	26	DR1D21
DRAM_D22	27	DR1D22
DRAM_D23	28	DR1D23

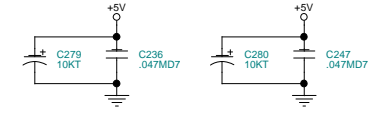
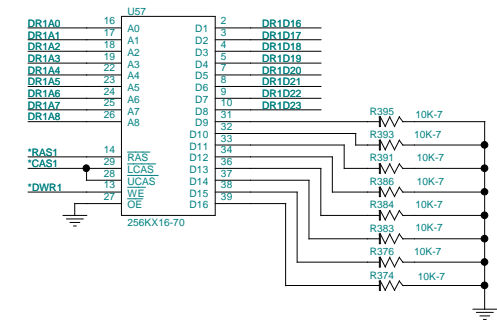
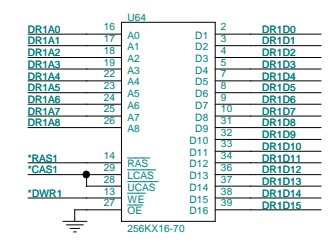

Digitech	
8760 South Sandy Parkway Sandy, Utah 84070	
Title JM-250 Main Board 80-6295	
Size B	Document Number 055093AI.007
Date: Tuesday, July 11, 2000	Rev A1
Sheet 7 of 14	

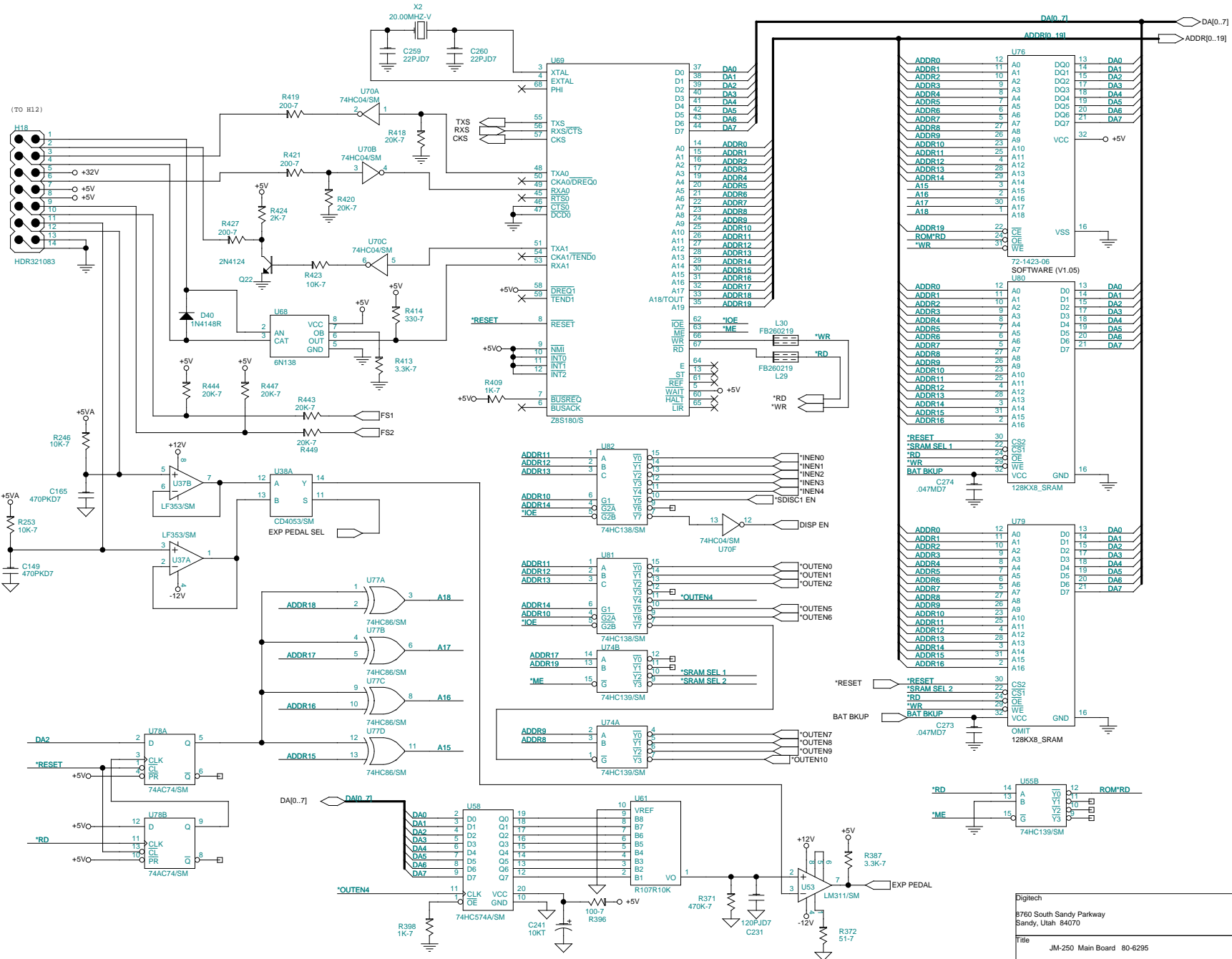

Digitech		
8760 South Sandy Parkway Sandy, Utah 84070		
Title JM-250 Main Board 80-6295		
Size B	Document Number 055093AI.008	Rev A1
Date: Tuesday, July 11, 2000	Sheet 8 of 14	

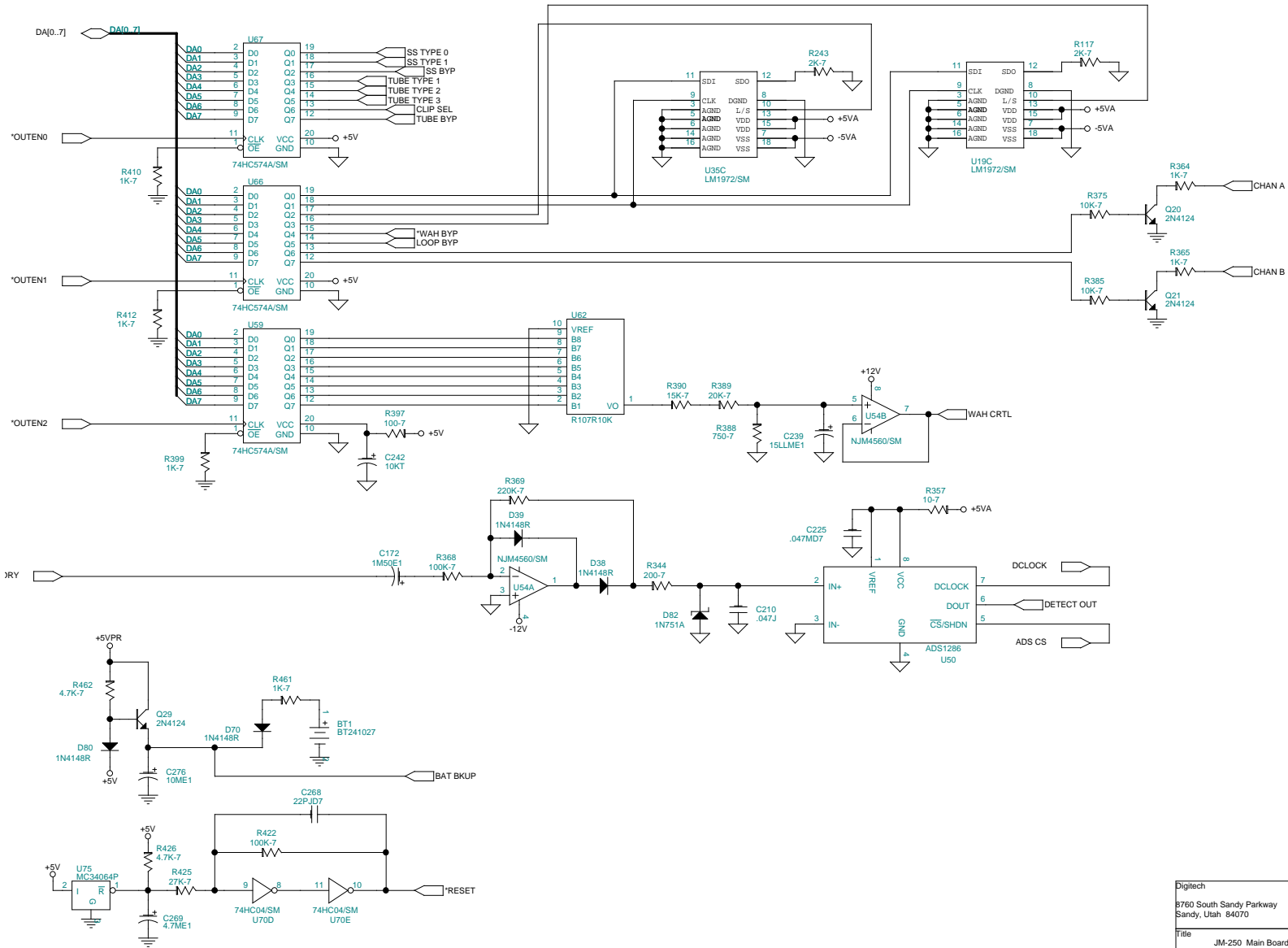

Digttech		
8760 South Sandy Parkway Sandy, Utah 84070		
Title JM-250 Main Board 80-6295		
Size B	Document Number 055093AI.009	Rev AI
Date:	Tuesday, July 11, 2000	Sheet 9 of 14

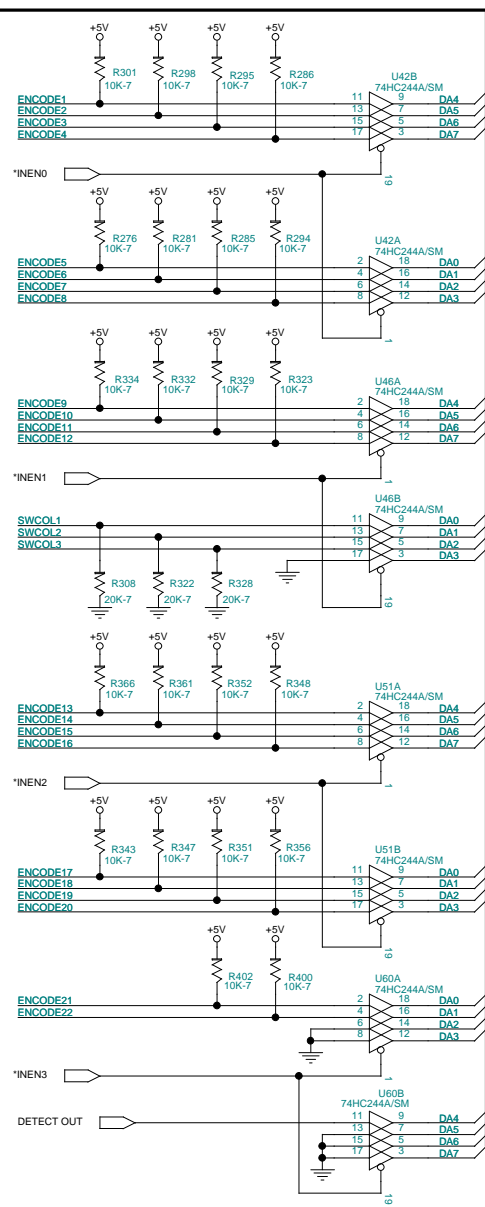
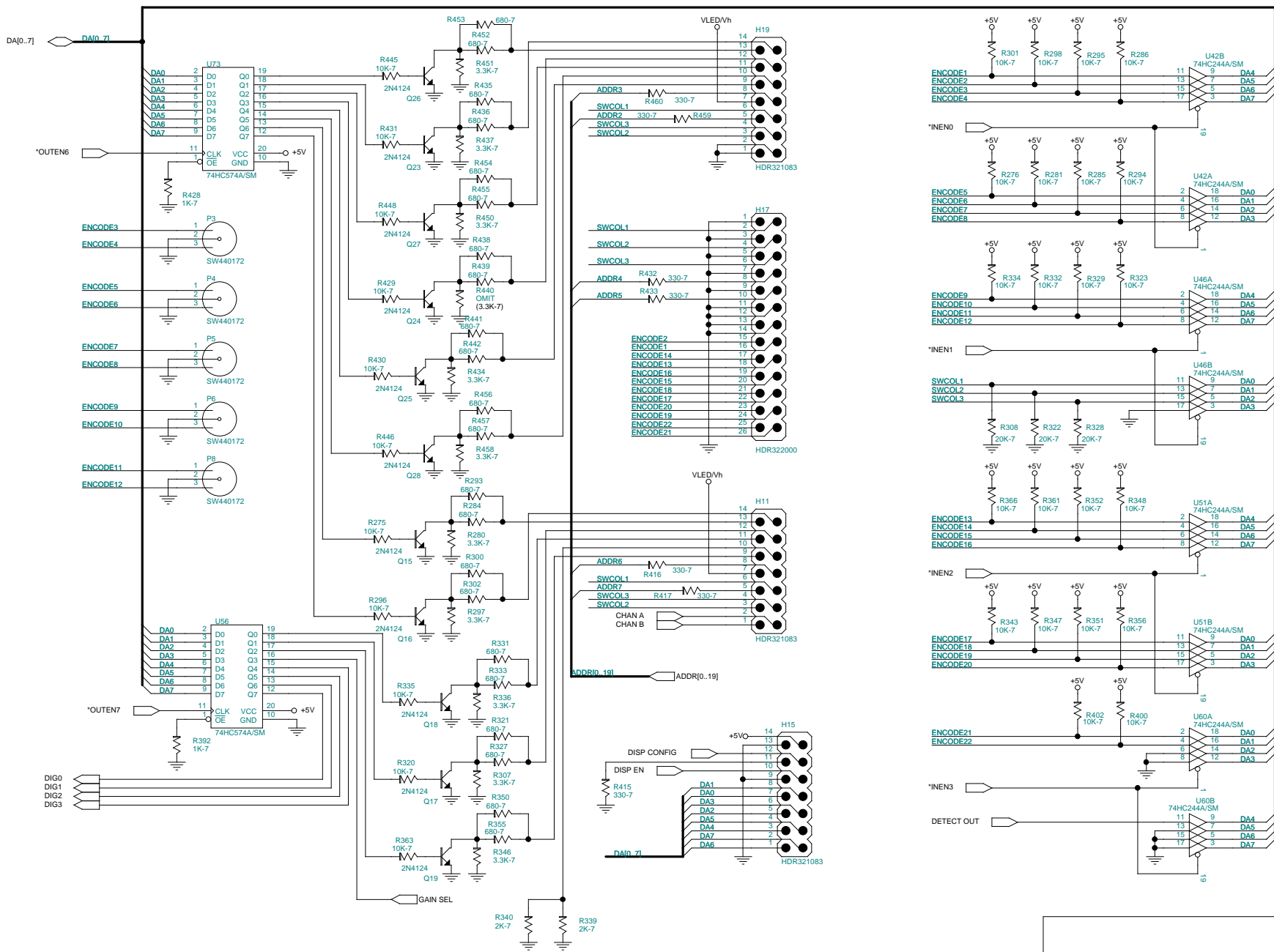

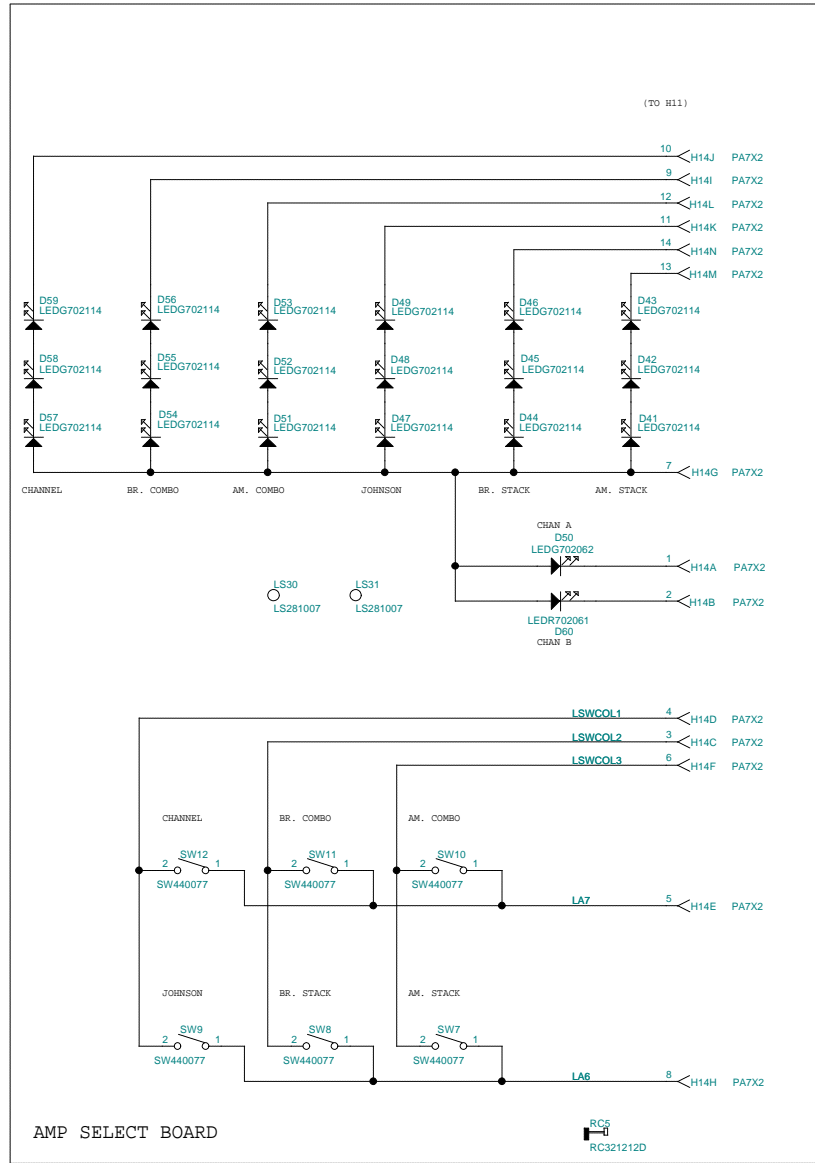
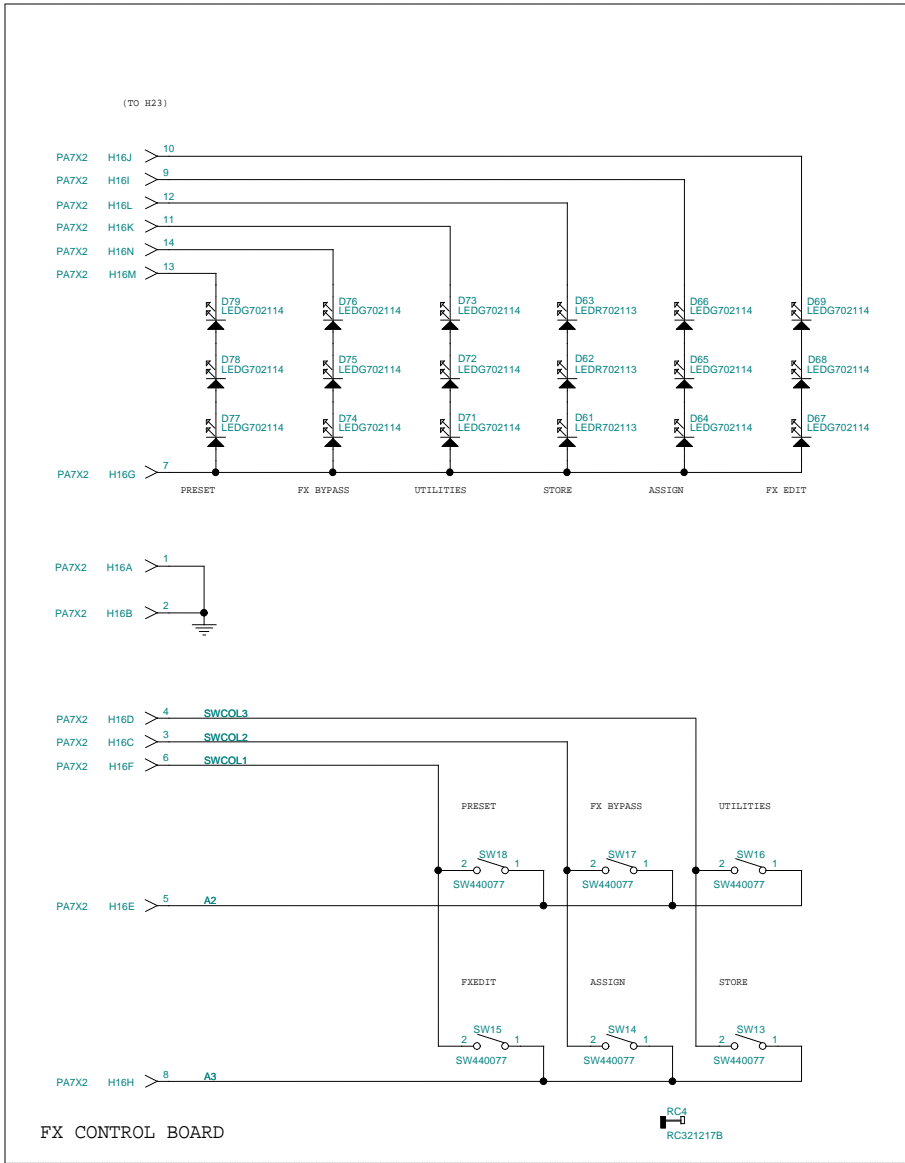

Digitech		
8760 South Sandy Parkway Sandy, Utah 84070		
Title JM-250 Main Board 80-6295		
Size B	Document Number 055093AI.011	Rev A1
Date:	Tuesday, July 11, 2000	Sheet 11 of 14

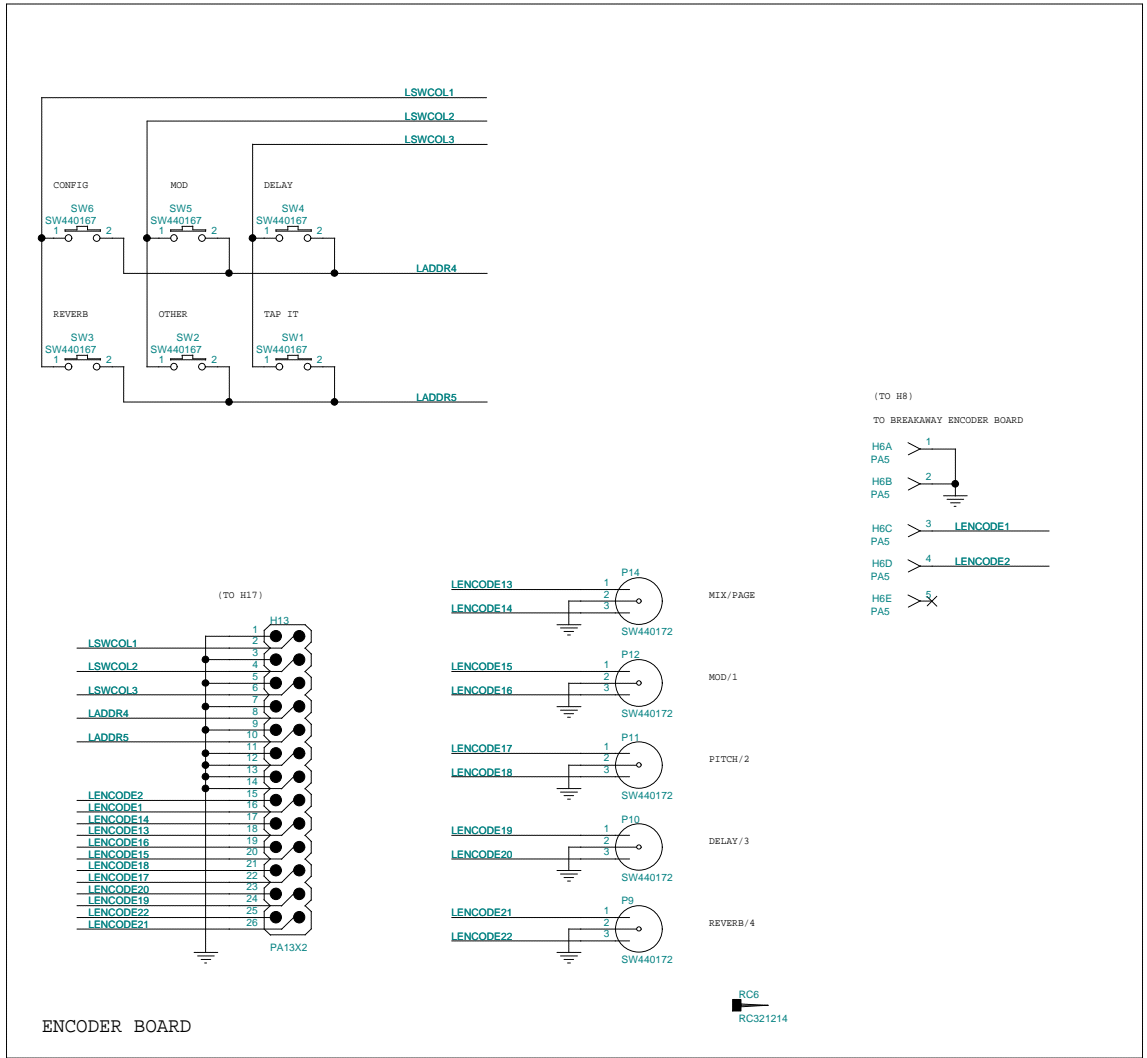

ENCODER BOARD

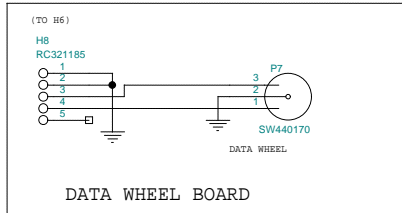

DATA WHEEL BOARD

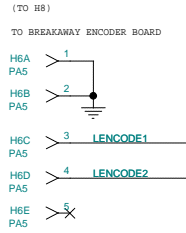

Digitech		
8760 South Sandy Parkway Sandy, Utah 84070		
Title JM-250 Main Board 80-6295		
Size B	Document Number 055093AI.012	Rev A1
Date:	Tuesday, July 11, 2000	Sheet 12 of 14

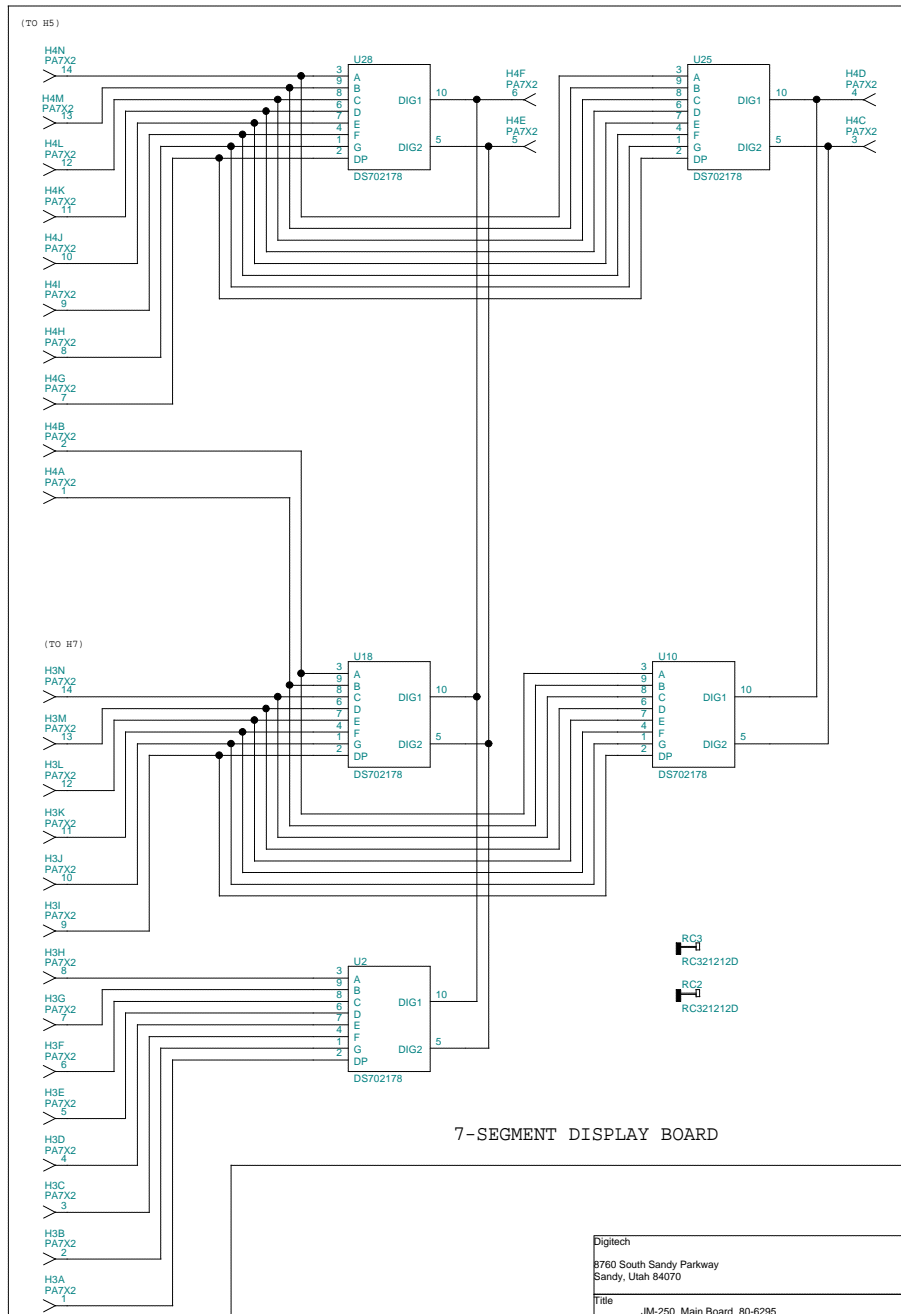
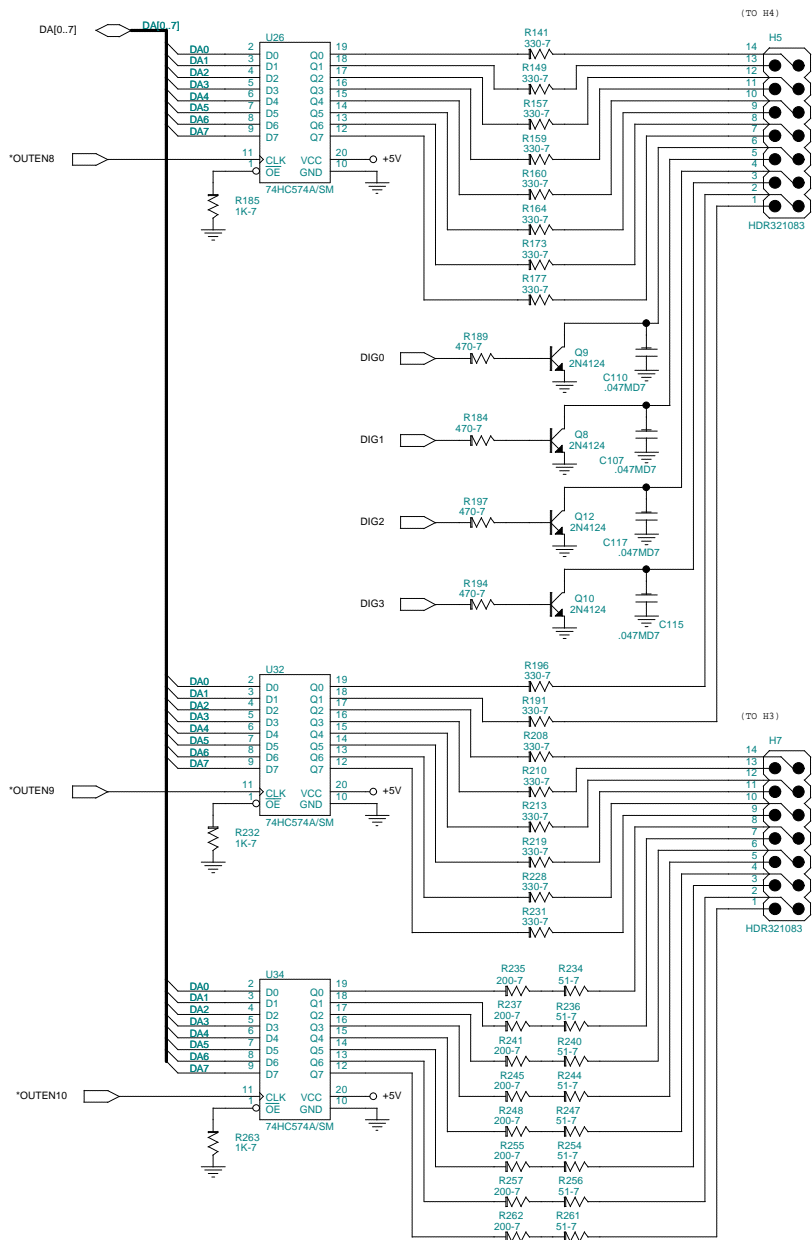

7-SEGMENT DISPLAY BOARD

Digitech	
8760 South Sandy Parkway Sandy, Utah 84070	
Title JM-250 Main Board 80-6295	
Size B	Document Number 055093AI.013
Date: Tuesday, July 11, 2000	Rev A1

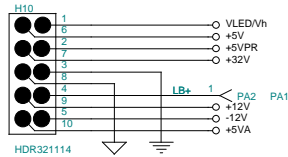
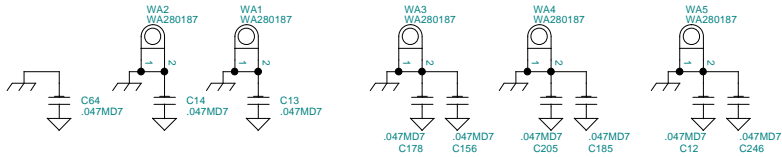
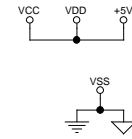
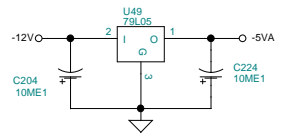
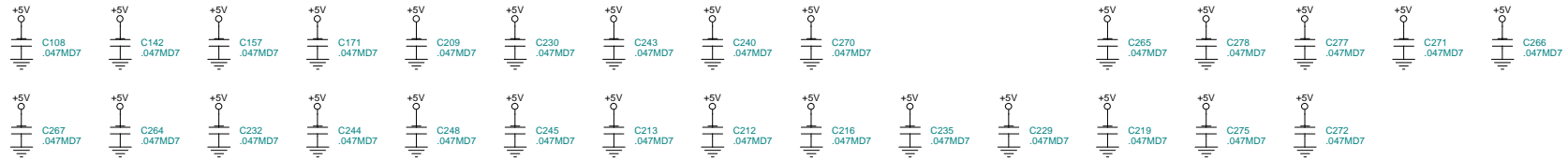
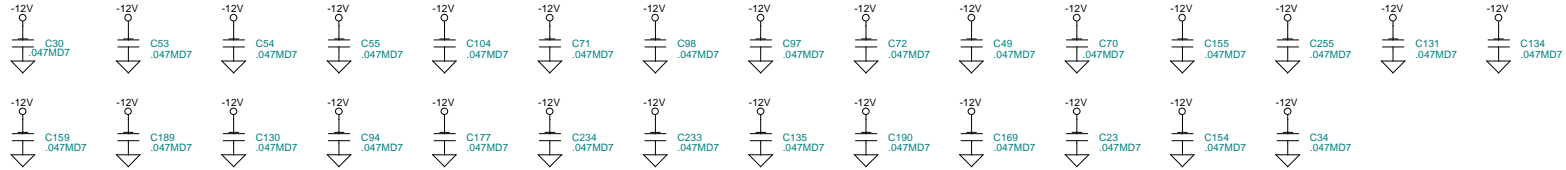
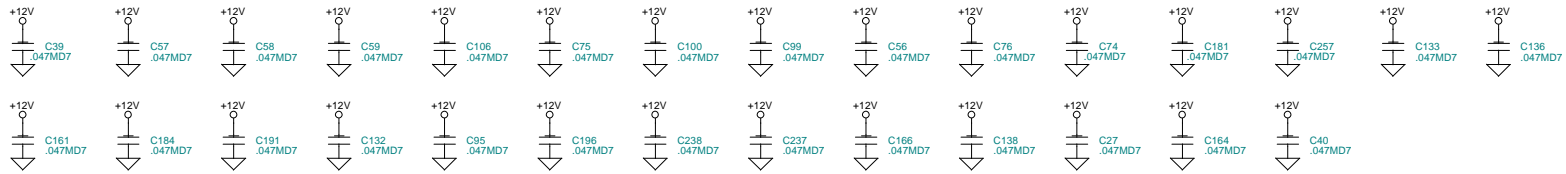

Digitech		
8760 South Sandy Parkway Sandy, Utah 84070		
Title JM-250 Main Board 80-6295		
Size B	Document Number 055093AI.014	Rev A1
Date: Tuesday, July 11, 2000	Sheet 14	of 14

Quan	Reference	Part	SYMAN	Description
1	BT1	BT241027	24-1027	3V Battery, Lithium, W/tabs, Horiz PCB Mount
117	C1,C11,C12,C13,C14,C23,C27,C30,C34,C39,C40,C49,C53,C54,C55,C56,C57,C58,C59,C64,C70,C71,C72,C74,C75,C76,C90,C94,C95,C97,C98,C99,C100,C104,C106,C107,C108,C110,C115,C117,C130,C131,C132,C133,C134,C135,C136,C138,C142,C154,C155,C156,C157,C159,C161,C164,C166,C169,C171,C177,C178,C179,C181,C184,C185,C189,C190,C191,C196,C205,C206,C209,C212,C213,C214,C215,C216,C218,C219,C220,C221,C222,C225,C226,C228,C229,C230,C232,C233,C234,C235,C236,C237,C238,C240,C243,C244,C245,C246,C247,C248,C252,C253,C255,C257,C264,C265,C266,C267,C270,C271,C272,C273,C274,C275,C277,C278	.047MD7	62-3129	.047 uF Cap 50V 20% Cerm, SMT 0805
29	C2,C5,C7,C16,R19,C20,C25,C28,R35,C43,C48,R51,R52,R53,R59,C61,R67,R68,U79,C93,R96,R131,R134,R211,R220,C261,C262,C263,R440	OMIT	00-0000	This part has been omitted
2	C3,C6	33LLME1	60-0059-01	33 uF Cap 16V 20% Elect., LL T&R
2	C4,C8	10S400E	60-0310	10 uF Cap 400V -20/+80% Elect
1	C9	.22J	56-0014	.22 uF Cap 50V 5% Stacked Metal Pet 224J ammo
5	C10,C122,C128,C129,C140	.47J	56-0016	.47 uF Cap 50V 5% Stacked Metal Pet 474J ammo
2	C15,C36	220PKD7	62-3138	220 pF Cap 50V 10% Cerm, SMT 0805
2	C17,C18	.0082K250F	56-2219	.0082 uF Cap 250V 10% Poly Film
1	C19	820PMD1	62-0005	820 pF Cap 50V 20% Ceramic Disc T&R
1	C21	.33J	56-0015	.33 uF Cap 50V 5% Stacked Metal Pet 334J ammo
7	C22,C153,C162,C187,C195,C200,C201	.0022J	56-0002	.0022 uF Cap 50V 5% Poly Film 222J ammo
2	C24,C31	.1J400F	56-2218	.1 uF Cap 400V 5% Poly Film
24	C26,C37,C38,C42,C60,C67,C68,C73,C79,C80,C81,C82,C83,C85,C89,C112,C114,C146,C147,C148,C151,C158,C160,C168	10NPME1	60-0051-01	10 uF Cap 16V -20/+20% Elect., NP T&R
1	C29	.068J	56-0011	.068 uF Cap 50V 5% Stacked Metal Pet 683J ammo
2	C32,C33	.10J	56-0012	.10 uF Cap 50V 5% Stacked Metal Pet 104J ammo
3	C41,C62,C84	.0047J	56-0004	.0047 uF Cap 50V 5% Poly Film 472J ammo
3	C44,C46,C65	.0068J	56-0005	.0068 uF Cap 50V 5% Poly Film 682J ammo
6	C45,C51,C125,C143,C152,C163	.015J	56-0007	.015 uF Cap 50V 5% Poly Film 153J ammo
8	C47,C69,C91,C92,C170,	120PJD7	62-3135	120 pF Cap 50V 5% Cerm, SMT 0805

	C183,C192,C231								
3	C50,C188,C194	.0010J	56-0000	.0010	uF Cap	50V 5% Poly Film 102J	ammo		
8	C52,C77,C172,C207,C211, C217,C223,C227	1M50E1	60-0044-01	1.0	uF Cap	50V -20/+20% Elect.,	T&R C&F		
5	C63,C113,C116,C120,C210	.047J	56-0010	.047	uF Cap	50V 5% Stacked Metal Pet	473J ammo		
10	C66,C127,C137,C249,C250, C251,C258,C259,C260,C268	22PJD7	62-3134	22	pF Cap	50V 5% Cerm,	SMT 0805		
2	C78,C88	.022J	56-0008	.022	uF Cap	50V 5% Poly Film 223J	ammo		
6	C86,C173,C202,C204,C224, C276	10ME1	60-0049-01	10	uF Cap	16V -20/+20% Elect.,	-D Ammo		
10	C87,C109,C111,C118,C139, C141,C150,C167,C174,C203	.010J	56-0006	.010	uF Cap	50V 5% Poly Film 103J	ammo		
2	C96,C123	15NPSE1	60-0053-01	15	uF Cap	16V -20/+80% Elect.,	NP T&R		
4	C101,C119,C186,C193	150PMD1	62-0031	150	pF Cap	50V 20% Ceramic Disc	T&R		
6	C102,C121,C149,C165,C254, C256	470PKD7	62-3133	470	pF Cap	50V 10% Cerm,	SMT 0805		
1	C103	TP500317	50-0317	0	Ohm Test Pt	5% 1/4 Watt Carbon Film	Radial T&R		
3	C105,C126,C144	.15J	56-0013	.15	uF Cap	50V 5% Stacked Metal Pet	154J ammo		
2	C124,C145	1NPMEL	60-0046-01	1.0	uF Cap	16V -20/+20% Elect.,	N.P. T&R		
5	C175,C176,C198,C199,C239	15LLME1	60-0052-01	15	uF Cap	16V 20% Elect.,	LL T&R		
2	C180,C197	.0027J	56-0027	.0027	uF Cap	50V 5% Poly Film 272J	ammo		
2	C182,C208	.033J	56-0009	.033	uF Cap	50V 5% Poly Film 333J	ammo		
4	C241,C242,C279,C280	10KT	62-0163	10	uF Cap	16V 10% Tantalum	T&R		
1	C269	4.7ME1	60-0048-01	4.7	uF Cap	16V -20/+20% Elect.,	T&R		
42	D1,D3,D4,D5,D6,D7,D8,D9, D10,D11,D12,D13,D14,D15, D16,D17,D18,D19,D20,D21, D22,D23,D24,D25,D26,D27, D28,D29,D30,D31,D32,D33, D34,D35,D36,D37,D38,D39, D40,D70,D80,D81	1N4148R	70-0004	1N4148	Diode Silicon Switching,	75 Volts PIV,	RADIAL		
1	D2	LEDR701902	70-1902		LED Red,	RT. ANGLE, anti-tip housing			
33	D41,D42,D43,D44,D45,D46, D47,D48,D49,D51,D52,D53, D54,D55,D56,D57,D58,D59, D64,D65,D66,D67,D68,D69, D71,D72,D73,D74,D75,D76, D77,D78,D79	LEDR702114	70-2114		Green Light Emitting Diode,	T1 (AUTO INSERT)			
1	D50	LEDR702062	70-2062		LED Green,	T1 Case (HAND STUFF ONLY)			
1	D60	LEDR702061	70-2061		LED Red,	T1 Case (HAND STUFF ONLY)			
3	D61,D62,D63	LEDR702113	70-2113		Red Light Emitting Diode,	T1 (AUTO INSERT)			
1	D82	1N751A	70-0003	1N751A	Diode Zener Glass,	1/2W 5.1V, DO-35			
2	H1,H6	PA5	00-0000	5	Pin Pad Pattern,	Not a part			
2	H2,H8	RC321185	32-1185	5	Pin Ribbon Cable Flex,	0.1" spacing, 2.00" Length,	Open end		
5	H3,H4,H12,H14,H16	PA7X2	00-0000	7X2	Pin Pad Pattern,	Not a part			
7	H5,H7,H9,H11,H15,H18,H19	HDR321083	32-1083	14	Pin Hdr,	7x2, 0.1" spacing, 0.025 pins,	.375		
1	H10	HDR321114	32-1114	5X2	Pin Vertical Header,	.165" Spacing, Dual Row W/Mtg Pegs			
1	H13	PA13X2	00-0000	13X2	Pin Pad Pattern,	Not a part			
1	H17	HDR322000	32-2000	26	Pin Hdr,	13x2, 0.1" spacing, 0.025 pins			
5	J1,J2,J3,J4,J7	J320119	32-0119	1/4	Phone Jack,	Hor. Mount, Full Nose Thread Slimline			
2	J5,J6	J320116	32-0116	JACK,	Shielded 5 pin DIN,	PCB mount			
1	J8	J320092	32-0092	5	Pin DIN Jack				

DOD Software

JM-250 Main Board 80-6295

055093AI.000

Bill Of Materials

Quan Reference

Revised: June 20, 2000
Revision: AI
June 20, 2000 13:01:24
Part SYMAN Description

Page

28 L1,L2,L3,L4,L5,L6,L8,L9,
L10,L11,L12,L13,L14,L15,
L16,L20,L21,L22,L23,L24,
L25,L26,L27,L28,L31,L32,

FB260217 26-0217 Ferrite Bead, 2.5Kohms @70Mhz, SMT 0805

Quan	Reference	Part	SYMAN	Description
	L33,L34			
1	L7	600UH	26-0196	600 uH Inductor
5	L17,L18,L19,L29,L30	FB260219	26-0219	Ferrite Bead, 600 ohms @100Mhz, SMT 0805
2	LS30,LS31	LS281007	28-1007	Led Standoff, 0.187" OD x 0.120" ID x 0.330" Length
3	P1,P13,P15	100K402011	40-2011	100 K "W" 16mm, Rot Pot x2, Rack Leads
1	P2	5K420219	42-0219	5 K Trim Pot, Vertical Mount, 10mm
10	P3,P4,P5,P6,P8,P9,P10, P11,P12,P14	SW440172	44-0172	Encoder Switch,24 Pos/Dtnt,2-bit,R/A,16mm body,15mm D-shaft
1	P7	SW440170	44-0170	Encoder Switch, 32 Position, Vert, 17mm shaft
2	PA1,PA2	PA1	00-0000	1 Pin Pad Pattern, Not a part
1	PA3	PA10079	00-0000	10 Pin Pad Pattern, Not a part, 2MM Spacing
1	PCB1	80-6295-A	80-6295-A	DigiTech, JM-150/JM-250 MAIN PCB, RAW
3	Q1,Q5,Q13	J112	70-1012	J112A JFET, National Only
1	Q2	2N4125	70-1008	2N4125 PNP, Gen. Purp. Amplifier/Switching Xstr
6	Q3,Q4,Q6,Q7,Q11,Q14	2N5088	70-1007	2N5088 NPN, Transistor, T&R
19	Q8,Q9,Q10,Q12,Q15,Q16, Q17,Q18,Q19,Q20,Q21,Q22, Q23,Q24,Q25,Q26,Q27,Q28, Q29	2N4124	70-1009	2N4124 NPN, Gen. Purp. Amplifier/Switching Xstr T&R
27	R1,R7,R40,R65,R70,R82, R84,R89,R106,R112,R114, R117,R143,R150,R176,R179, R198,R243,R251,R283,R290, R291,R313,R314,R339,R340, R424	2K-7	50-1508	2 KOhm Resistor 5% 1/10 Watt TF, SMT 0805
13	R2,R8,R20,R37,R44,R72, R81,R92,R98,R142,R405, R407,R408	1M-7	50-1506	1 MOhm Resistor 5% 1/10 Watt TF, SMT 0805
3	R3,R13,R36	62K-7	50-1501	62 KOhm Resistor 5% 1/10 Watt TF, SMT 0805
90	R4,R5,R9,R14,R17,R18,R30, R48,R50,R54,R57,R69,R74, R75,R77,R80,R86,R94,R97, R116,R118,R119,R126,R158, R161,R167,R171,R175,R190, R193,R199,R216,R218,R227, R238,R242,R246,R253,R269, R272,R275,R276,R281,R282, R285,R286,R287,R288,R294, R295,R296,R298,R301,R309, R310,R320,R323,R325,R329, R332,R334,R335,R343,R347, R348,R351,R352,R356,R361, R363,R366,R374,R375,R376, R383,R384,R385,R386,R391, R393,R395,R400,R402,R423, R429,R430,R431,R445,R446, R448	10K-7	50-1503	10 KOhm Resistor 5% 1/10 Watt TF, SMT 0805
24	R6,R250,R284,R293,R300, DOD Software	680-7	50-1511	680 Ohm Resistor 5% 1/10 Watt TF, SMT 0805
JM-250 Main Board 80-6295 Revised: June 20, 2000				
055093AI.000 Revision: AI				
Bill Of Materials June 20, 2000 13:01:24				
Quan Reference Part SYMAN Description				

Page

24	R10,R12,R28,R43,R49,R76, R78,R110,R133,R137,R151, R162,R163,R165,R169,R187, R204,R206,R212,R217,R226, R268,R368,R422	100K-7	50-1504	100 KOhm Resistor 5% 1/10 Watt TF, SMT 0805
11	R11,R55,R168,R195,R222,	6.8K-7	50-1513	6.8 KOhm Resistor 5% 1/10 Watt TF, SMT 0805

	R225,R233,R258,R259,R266, R267									
24	R15,R33,R79,R83,R85,R87, R105,R183,R308,R322,R328, R359,R362,R377,R380,R381, R382,R389,R418,R420,R443, R444,R447,R449	20K-7	50-1507	20	KOhm Resistor	5%	1/10 Watt	TF, SMT	0805	
16	R16,R31,R34,R95,R103, R108,R111,R122,R135,R170, R172,R182,R186,R221,R426, R462	4.7K-7	50-1509	4.7	KOhm Resistor	5%	1/10 Watt	TF, SMT	0805	
12	R21,R22,R24,R25,R26,C35, R41,R47,R102,R378,R379, R403	0-7	50-1531	0	Ohm Resistor	5%	1/10 Watt	TF, SMT	0805	
7	R23,R42,R66,R104,R107, R136,R140	47K-7	50-1502	47	KOhm Resistor	5%	1/10 Watt	TF, SMT	0805	
10	R27,R29,R32,R152,R166, R205,R209,R229,R265,R369	220K-7	50-1514	220	KOhm Resistor	5%	1/10 Watt	TF, SMT	0805	
6	R38,R148,R184,R189,R194, R197	470-7	50-1518	470	Ohm Resistor	5%	1/10 Watt	TF, SMT	0805	
39	R39,R60,R63,R88,R90,R91, R100,R113,R115,R125,R127, R144,R145,R146,R147,R153, R154,R155,R180,R185,R232, R252,R263,R274,R289,R292, R299,R312,R315,R364,R365, R392,R398,R399,R409,R410, R412,R428,R461	1K-7	50-1505	1	KOhm Resistor	5%	1/10 Watt	TF, SMT	0805	
9	R45,R46,R62,R132,R156, R270,R277,R324,R371	470K-7	50-1523	470	KOhm Resistor	5%	1/10 Watt	TF, SMT	0805	
4	R56,R58,R207,R223	33K-7	50-1512	33	KOhm Resistor	5%	1/10 Watt	TF, SMT	0805	
7	R61,R99,R174,R192,R390, R406,R411	15K-7	50-1516	15	KOhm Resistor	5%	1/10 Watt	TF, SMT	0805	
29	R64,R124,R141,R149,R157, R159,R160,R164,R173,R177, R178,R188,R191,R196,R208, R210,R213,R219,R228,R231, R249,R414,R415,R416,R417, R432,R433,R459,R460	330-7	50-1517	330	Ohm Resistor	5%	1/10 Watt	TF, SMT	0805	
4	R71,R93,R138,R214	75K-7	50-1520	75	KOhm Resistor	5%	1/10 Watt	TF, SMT	0805	
1	R73	150K-7	50-1526	150	KOhm Resistor	5%	1/10 Watt	TF, SMT	0805	
2	R101,R181	7.5K-7	50-1521	7.5	KOhm Resistor	5%	1/10 Watt	TF, SMT	0805	

DOD Software

JM-250 Main Board 80-6295

055093AI.000

Bill Of Materials

Quan Reference

Revised: June 20, 2000
Revision: AI
June 20, 2000 13:01:24
Part SYMAN Description

Page

24	R109,R120,R128,R129,R260, R271,R273,R278,R279,R280, R297,R307,R311,R326,R330, R336,R346,R387,R413,R434, R437,R450,R451,R458	3.3K-7	50-1525	3.3	KOhm Resistor	5%	1/10 Watt	TF, SMT	0805	
15	R121,R130,R234,R236,R240, R244,R247,R254,R256,R261, R303,R304,R305,R306,R372	51-7	50-1524	51	Ohm Resistor	5%	1/10 Watt	TF, SMT	0805	
2	R123,R425	27K-7	50-1527	27	KOhm Resistor	5%	1/10 Watt	TF, SMT	0805	
2	R139,R215	330K-7	50-1519	330	KOhm Resistor	5%	1/10 Watt	TF, SMT	0805	
4	R200,R201,R202,R203	10.0K 1%-7	52-4500	10.0	KOhm Resistor	1%	1/10 Watt	TF, SMT	0805	
2	R224,R230	22K-7	50-1522	22	KOhm Resistor	5%	1/10 Watt	TF, SMT	0805	
13	R235,R237,R241,R245,R248, R255,R257,R262,R344,R394, R419,R421,R427	200-7	50-1510	200	Ohm Resistor	5%	1/10 Watt	TF, SMT	0805	
2	R239,R264	39K-7	50-1528	39	KOhm Resistor	5%	1/10 Watt	TF, SMT	0805	

11	R316,R317,R318,R319,R341, R342,R360,R396,R397,R401, R404	100-7	50-1515	100	Ohm Resistor 5% 1/10 Watt TF, SMT 0805
11	R337,R338,R345,R349,R353, R354,R357,R358,R367,R370, R373	10-7	50-1500	10	Ohm Resistor 5% 1/10 Watt TF, SMT 0805
1	R388	750-7	50-1530	750	Ohm Resistor 5% 1/10 Watt TF, SMT 0805
2	R463,R464	0	50-0050	0	Ohm Resistor 5% 1/4 Watt Carbon Film
1	RC1	RC321219A	32-1219-A	10	Pin Ribbon Cable, 2mm spacing, 7.00" Length
4	RC2,RC3,RC5,RC8	RC321212D	32-1212-D	14	Pin Ribbon Cable, 2mm 7x2spacing, 4.25" Length
1	RC4	RC321217B	32-1217-B	14	Pin Ribbon Cable, .1 spacing, 6.25" Length MtoF
1	RC6	RC321214	32-1214	26	Pin Ribbon Cable Conn, .1 spacing, 13X2
2	RCH1,RCH2	RCH10079	32-1221	10	Pin Ribbon Cable, Holder, 2mm spacing
2	SV1,SV2	TUBE9S	32-0250	9	Pin Tube Socket
6	SW1,SW2,SW3,SW4,SW5,SW6	SW440167	44-0167		Lite Touch Switch, Right Angle
12	SW7,SW8,SW9,SW10,SW11, SW12,SW13,SW14,SW15,SW16, SW17,SW18	SW440077	44-0077		SPST Switch, Tact, Radial
22	U1,U3,U4,U6,U7,U8,U9,U13, U14,U15,U22,U27,U30,U31, U33,U36,U39,U40,U41,U44, U54,U65	NJM4560/SM	72-4233		NJM4560 Dual Op-Amp, SMT SOIC
5	U2,U10,U18,U25,U28	DS702178	70-2178		Display, Dual 7-segment, green
4	U5,U17,U38,U45	CD4053/SM	72-1422		Triple 2 to 1 Analog Multiplexer, SMT
1	U11	4051/SM	72-0085		8 to 1 Analog Multiplexer, SMT
1	U12	VTL5C3	70-2142		VTL5C3 Vactrol Led axial
2	U16,U20	2159	72-4262		VCA,THAT 2159 (DOD & Digitech)
2	U19,U35	LM1972/SM	72-4038		LM1972 2-Channel Audio Attenuator w/Mute, SMT
5	U21,U23,U29,U37,U43	LF353/SM	72-4032		LF353M Dual Op-Amp, SMT
1	U24	CD4052DA/S	72-0079		Dual 4-CH MUX, SOIC, SMT
10	U26,U32,U34,U56,U58,U59, U66,U67,U72,U73	74HC574A/S	72-1263		Octal D-Type Edge Triggered Flip-Flops, SMT
5	U42,U46,U51,U60,U71	74HC244A/S	72-1111		Octal Buffer-Line Driver W/3-State Outputs, SMT
1	U47	CS5335	72-3021		CS5335, 20 Bit Stereo, 105dB ADC, SMT
1	U48	CS4327	72-3020		CS4327, 20 Bit Stereo, 101dB DAC, SMT
1	U49	79L05	70-4127		79L05 -5 Volt 100 mA Voltage Regulator TO-92

DOD Software
 JM-250 Main Board 80-6295
 055093AI.000
 Bill Of Materials
 Quan Reference

Revised: June 20, 2000
 Revision: AI
 June 20, 2000 13:01:24
 Part SYMAN Description

1	U50	ADS1286	72-1420		CONVERTER, 12-Bit Serial A to D, SMT
1	U52	TMS57070	72-3042		TMS57070 in QFP100 SPECIAL FOOTPRINT, SMT
1	U53	LM311/SM	72-5415		LM311 Analog Voltage Comparator, SMT
2	U55,U74	74HC139/SM	72-5420		Dual 2 Line to 4 Line Decoder/Demultiplexer, SMT
2	U57,U64	256KX16-70	72-1419		DRAM, 256K x 16 70ns, SOJ, SMT
2	U61,U62	R107R10K	54-0353		8 Bit R-2R Ladder, 10.00 kOhm 2% Thick Film
1	U63	SDISC5500	72-5500		SDISCII W/I's Interface in QFP100 SPECIAL FOOTPRINT, SMT
1	U68	6N138	70-2139		6N138 Opto-Isolator
1	U69	Z8S180/S	72-4161		CPU Z8S180 Microprocessor, 20MHz, SMT
1	U70	74HC04/SM	72-1086		Hex Inverter 74HC04, SMT
1	U75	MC34064P	70-5004		MC34064 Undervoltage Sensing Circuit
1	U76	72-1423-06	72-1423-06		AT49F040-12JC 4 MEG Flash EEPROM,V1.05 (JM250H), SMT
1	U77	74HC86/SM	72-1404		74HC86 Quad 2-Input XOR Gate, SMT
1	U78	74AC74/SM	72-5425		74AC74 Dual D-Type Pos Edge Trig Flip-Flop, SMT
1	U80	128KX8_SRA	72-5417		128K X 8 RAM Static, SMT
2	U81,U82	74HC138/SM	72-5419		3 Line to 8 Line Decoder/Demultiplexer, SMT
2	V1,V2	12AX7A2	76-0002		12AX7A2 Tube
1	W1	W360030	36-0030		Wire, 2 End, 10.50", Black, 20AWG UL/CSA
5	WA1,WA2,WA3,WA4,WA5	WA280187	28-0187-A		Washer, for grounding J320119
1	X1	22.579 MHZ	76-0320		22.579 MHZ Crystal, Vert
1	X2	20.00MHZ-V	76-0321		20.00 MHZ Crystal, Vert