

**INSTALLATION MANUAL
FOR
JABIRU 3300 AIRCRAFT ENGINE**

DOCUMENT No. JEM3302-4



This Manual is a guide to correctly install the Jabiru 3300 engine into an airframe.

If you have any questions or doubts about the contents, please contact Jabiru Aircraft P/L.

**Applicable to Jabiru 3300cc Engines, S/No. 33A961 Onwards (Hydraulic Lifter Type)
(Including 33A927, 33A928, 33A947, 33A948, 33A949, 33A950)**



1.1	Table of Figures	3
1.2	List of Effective Pages	4
1	Description	5
1.1	Model	5
1.2	Manuals	5
1.3	Specifications	5
1.4	Dimensions	7
2	Engine Mount	9
3	Controls	11
3.1	Throttle and Choke	11
3.2	Ignition & Starter Systems	11
4	Engine Crankcase Breather, Catch Bottle & Dipstick	12
5	Electrical Equipment	13
5.1	Alternator	13
5.2	Regulator	13
5.3	Ignition	14
5.4	Starter Motor	15
5.5	Starter Solenoid	15
5.6	Battery	16
5.7	Wiring Practices	16
5.8	Instruments	17
5.9	Radio Frequency (RF) Noise Reduction	21
6	Fuel Supply System	25
6.1	Fuel Tank	25
6.2	Fuel Filtration	25
6.3	Mechanical Fuel Pump	25
6.4	Fuel Flow Meters	25
6.5	Carburettor	25
6.6	Fuel Lines	29
7	Air Intake System	30
7.1	Intake Air Heating	30
7.2	Intake Hose & Air Filter Box	30
7.3	Air Filter	32
7.4	Ram Air Bleed	32
8	Exhaust System	33
9	Propeller & Spinner	34
10	Engine Installation Procedure	36
11	Before First Start	41
12	Auxiliary Units	42
12.1	Vacuum Pump	42
13	Cooling Systems	43
13.1	General Principles	43
13.2	Flow Visualisation	45
13.3	Air Inlet & Ram Air Ducts	46
13.4	Oil Cooling	48
13.5	Air Outlet	49
13.6	Cooling System Testing & Evaluation	52
13.7	Pusher Installations	53
13.8	Amphibian or Seaplane Installations	53
13.9	Slow Speed Installations	54
14	Appendix A – Wiring Diagrams	55
15	Appendix B – Jabiru Aircraft Installation	56
15.1	Known Airframe / Engine Details	56
15.2	Normal Operation Data	56
16	Engine Installation Checklist	57



1.1 Table of Figures

Figure 1. Drawing W000509-2 Engine Dimensions	7
Figure 2. Cylinder Firing Order.....	8
Figure 3. Distributor Cylinder Map	8
Figure 4. Engine Mount Point Locations	9
Figures 5 & 6. Typical Upper Engine Mount, Air Intake Installation	10
Figure 7 Engine Mount Assembly	10
Figure 8. Choke and Throttle Connections to Carburettor	11
Figure 9. Crankcase Breather Installation.....	12
Figure 10. Ignition & Alternator Detail.....	13
Figure 11. Electrics Installation to Firewall.....	14
Figure 12. Regulator Plug Wiring Details.....	14
Figure 13. Ignition Coil Cooling Tube.....	15
Figure 14. Starter Wiring Details.....	16
Figure 15. Tachometer Sender Installation.....	17
Figure 16. Tachometer Connections.....	17
Figure 17. Oil Temperature Sender	18
Figure 18. Oil Temperature Connections.....	18
Figure 19. Oil Pressure Sender	19
Figure 20. Oil Pressure Connections	19
Figure 21. Voltage Gauge Connections.....	19
Figure 22. CHT Sender (Thermocouple) Installation	20
Figure 23. CHT Terminal Installation	21
Figure 24. CHT Gauge Connections.....	21
Figure 25. RG400 Co-Axial Antenna Cable	22
Figure 26. Wiring Diagram.....	23
Figure 27. Wiring Diagram Key.....	24
Figure 28. Mechanical Fuel Pump	25
Figure 29. Carburettor Installation	26
Figure 30. Carburettor Intake & Balance Tube Detail	27
Figure 31. Carburettor Schematic.....	27
Figure 32. Needle Jet (Jabiru Needle).....	28
Figure 33. Air Intake Connections.....	30
Figure 34. Air Filter Box Plumbing – Incorrect	31
Figure 35. Air Filter Box Plumbing – Correct.....	31
Figure 36. Typical “Cobra Head” Installation on a Jabiru Aircraft	31
Figure 37. Cobra Head for Installations with Minimum Carburettor Clearance	32
Figure 38. Ram Air Bleed.....	32
Figure 39. Jabiru Propeller & Spinner Installation.....	35
Figure 40. Engine Accessory Pack Contents.....	37
Figure 41 Upper & Lower Engine Mount Detail.....	37
Figure 42. Engine Mount Detail.....	38
Figure 43. Fuel Connections General.....	39
Figure 44. SCAT Hose Detail.....	39
Figure 45. Balance Tube Detail	39
Figure 46. Control Connections to Carburettor	40
Figure 47. Cowl Airflow (Best Viewed in Colour).....	44
Figure 48. Cowl Airflow (Black & White Version)	44
Figure 49. Flow Visualisation	45
Figure 50. Front-On View Into Ram Air Duct	46
Figure 51. Coil Cooling Detail	47
Figure 52. Ram Air Duct Front Seam.....	47
Figure 55. Air Dam Installation.....	48
Figure 52. Oil Cooler Duct Design	49
Figure 53. Oil Cooler Installation.....	49
Figure 54: Lip to aid cooling as installed on a Jabiru.....	50
Figure 55. Affect of Angle of Attack on Cowl Outlets	50
Figure 56. Cowl Outlet Geometry.....	51
Figure 57. Outlet Restriction Caused By Flange On Lower Firewall.....	51
Figure 58: Cooling pressure measurement.....	52
Figure 59: Ram Air duct pressure tapping.....	53
Figure 60. Augmentor Exhaust System	54
Figure 61. Wiring Details	55



1.2 List of Effective Pages

The dates of issue for original & revised pages are:

Page	Revision	Date	Page	Revision	Date	Page	Revision	Date
1	4	14-8-09	21	4	14-8-09	41	4	14-8-09
2	4	14-8-09	22	4	14-8-09	42	4	14-8-09
3	4	14-8-09	23	4	14-8-09	43	4	14-8-09
4	4	14-8-09	24	4	14-8-09	44	4	14-8-09
5	4	14-8-09	25	4	14-8-09	45	4	14-8-09
6	4	14-8-09	26	4	14-8-09	46	4	14-8-09
7	4	14-8-09	27	4	14-8-09	47	4	14-8-09
8	4	14-8-09	28	4	14-8-09	48	4	14-8-09
9	4	14-8-09	29	4	14-8-09	49	4	14-8-09
10	4	14-8-09	30	4	14-8-09	50	4	14-8-09
11	4	14-8-09	31	4	14-8-09	51	4	14-8-09
12	4	14-8-09	32	4	14-8-09	52	4	14-8-09
13	4	14-8-09	33	4	14-8-09	53	4	14-8-09
14	4	14-8-09	34	4	14-8-09	54	4	14-8-09
15	4	14-8-09	35	4	14-8-09	55	4	14-8-09
16	4	14-8-09	36	4	14-8-09	56	4	14-8-09
17	4	14-8-09	37	4	14-8-09	57	4	14-8-09
18	4	14-8-09	38	4	14-8-09			
19	4	14-8-09	39	4	14-8-09			
20	4	14-8-09	40	4	14-8-09			

Issue Notes:

Rev 0	Original Issue
Rev 1	
Rev 2	
Rev 3	Re-Format



1 Description

1.1 Model

This Manual applies to all Jabiru 3300 Engine Models, but particularly those from S/No 961 on. Details for operating and servicing are supplied in the Engine Instruction & Maintenance Manual.

Only those details relevant for installation are duplicated below – for all other information please refer to the Instruction & Maintenance Manual.

1.2 Manuals

Instruction and Maintenance Manual

Installation Manual

Parts Catalogue

1.3 Specifications

All information given in this manual assumes static sea level ratings under the following conditions:-

- International Standard Atmospheric conditions at sea level.
- Aircraft service equipment drives unloaded. (Vacuum Pump not fitted)
- Full rich fuel/air mixture.
- Standard Jabiru air filter and hot air mixer box assembly.
- Standard exhaust muffler.
- Jabiru Propeller
- Jabiru Airframe

1.3.1 Engine Models

- The 3300L engine has a maximum continuous RPM rating of 2850RPM. The engine may be operated at engine speeds above 2850RPM for up to 10 minutes.
- All other engine specifications and limitations are identical to other 3300 models (such as the 3300A).
- The 3300L uses the same parts, Parts Books, Servicing, Maintenance and Overhaul Information as other 3300 models.
- Unless specifically stated otherwise, all Service Letters, Service Bulletins, Manufacturer Safety Directions and other service information issued for Jabiru 3300 engines is applicable to 3300L models.

1.3.2 Engine Ratings

Table 1 – Engine Ratings

Model:	3300L	All Other 3300 Models
Maximum Power	90 kW (120 hp) @ 3300 RPM - ISO STD Conditions	
Fuel Consumption	35 L/hr @ Takeoff Rating 26 L/hr @ Continuous Rating	35 L/hr @ Takeoff/Max Continuous Rating
Oil Consumption	0.1 L/hr (max)	

Note that fuel and oil consumption figures are based on a typical installation in a Jabiru Aircraft. Values will differ for other installations.

1.3.3 Fuel

Fuel Consumption:..... 35 L/hr @ Takeoff Rating

Fuel Consumption:..... 24 L/hr @ 75% nominal power setting.

1.4 Dimensions

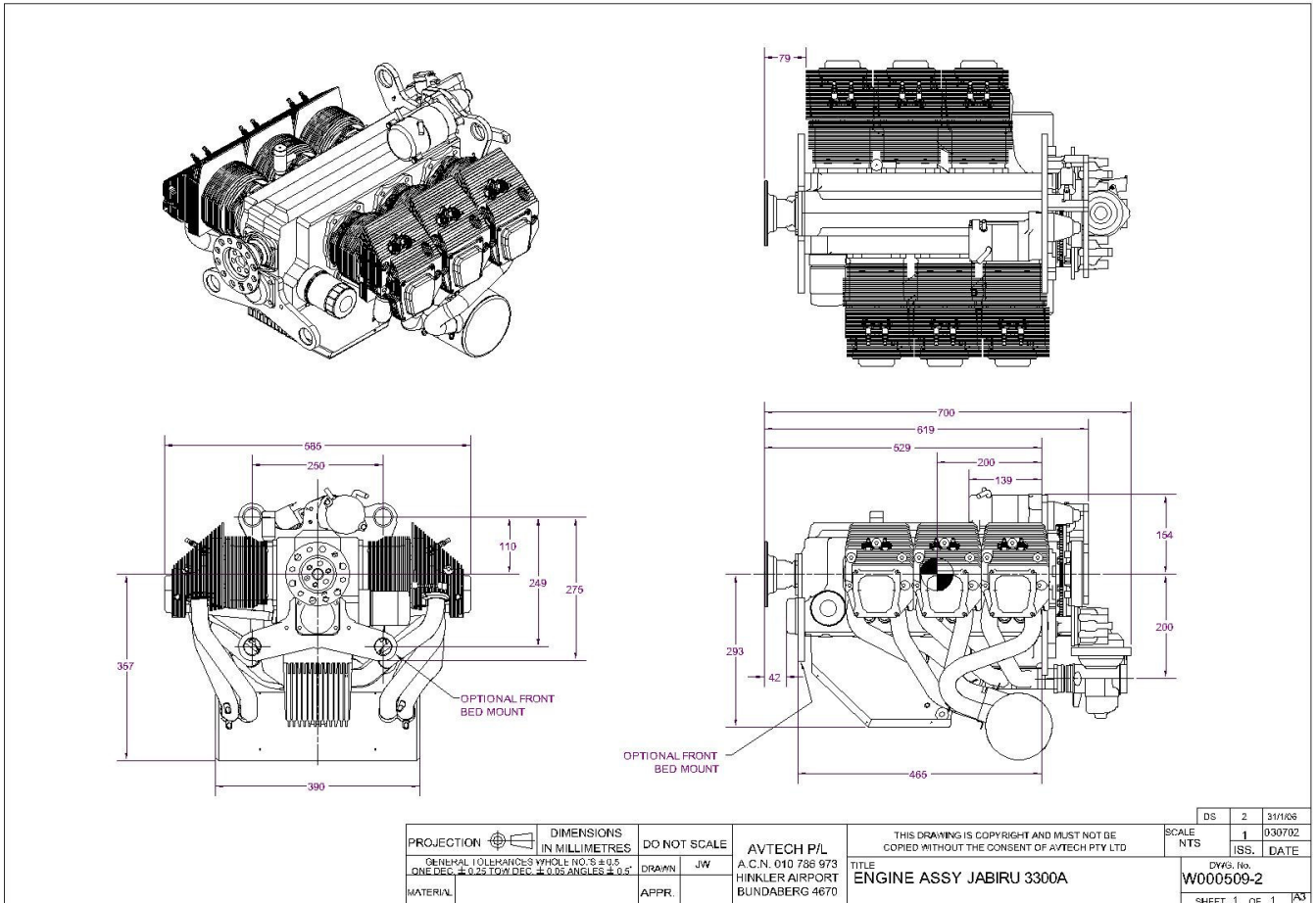
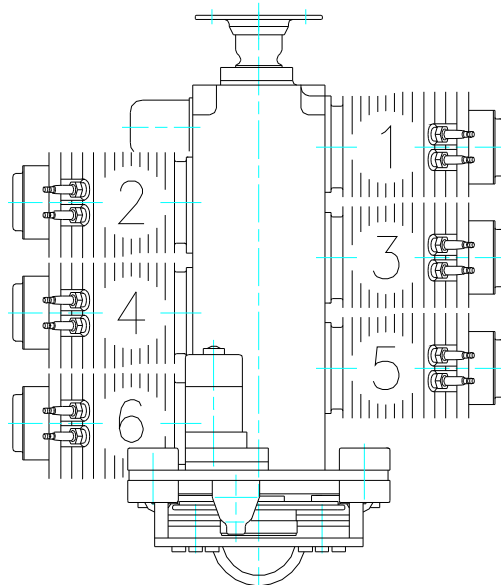

Figure 1. Drawing W000509-2 Engine Dimensions

1.4.1 Denomination Of Cylinders



Drawing 9476083

Figure 2. Cylinder Firing Order

Cylinder Firing Order: 1 – 4 – 5 – 2 – 3 – 6

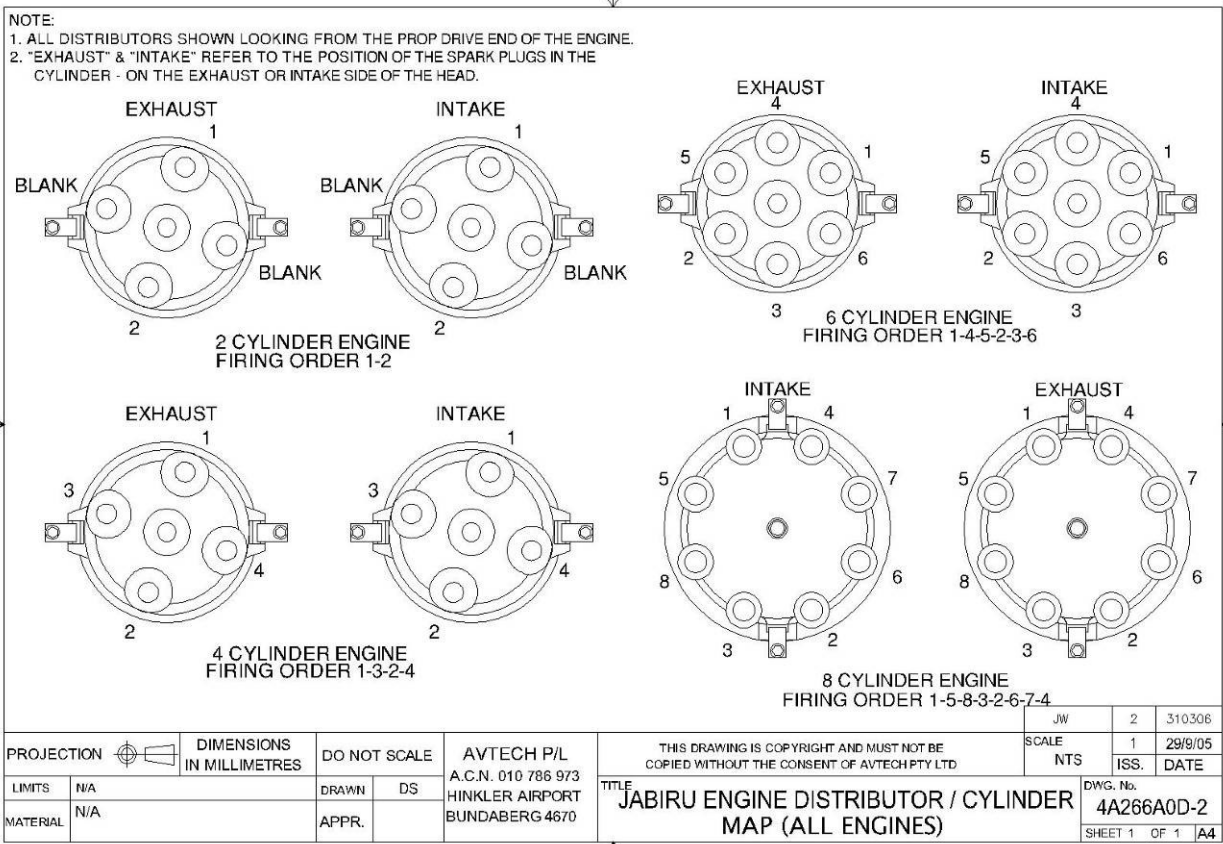

Figure 3. Distributor Cylinder Map

2 Engine Mount

The design of the engine mount must balance many requirements:

- The mount must be strong enough to carry the loads applied by the weight and power of the engine.
- The mount must be stiff enough that the engine does not sag or move too much when power is applied.
- The mount must position the engine at the correct height and angle so that the engine's thrust line suits the aircraft. In most installations, Jabiru Engines need to have their thrust axis offset to the right (tractor installations) by between 1° and 2°.
- The mount must position the engine at the right place. The weight of the engine is a very significant part of the overall aircraft weight, and it's position must be calculated to place the centre of gravity of the aircraft (CG) in the right spot.
- The mount must be designed to allow enough room for the air intake to the Carburettor as well as accessories like vacuum pumps. Access for maintenance must also be considered.
- The final design of the engine mount is a compromise, and sometimes special parts will be required to make it work. Figure 6 shows the installation of a Jabiru 8-cylinder engine into a Van's RV-6. To give a good CG location the engine had to be mounted as close to the firewall as possible. This meant that custom air intake tubes had to be developed to get the intake air to the carburettor with a minimum disturbance and turbulence.

The engine has four engine mounting points located at the rear of the engine (shown in Figure 1 or Figure 4) from which the engine is to be mounted. An optional bed mount may be fitted.

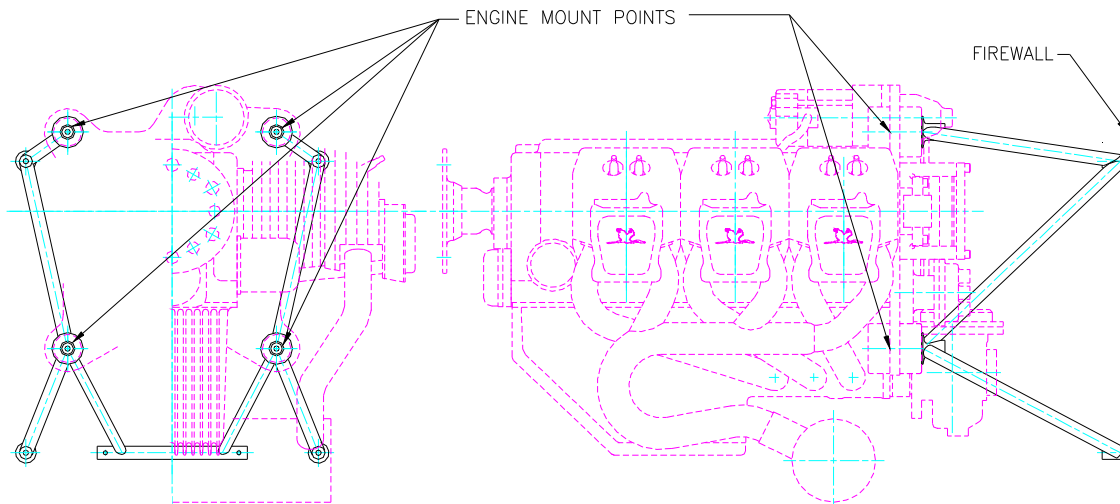

Figure 4. Engine Mount Point Locations

- Each engine mounting point is rubber mounted to damp the engine vibrations. The correct installation of these rubbers is shown below in Figure 4.
- If required, corrections of the engine angle or propeller position can be made by fitting spacers under the rubber cushions. The maximum spacer thickness on any one mount is 3mm.

Custom air intake tube ("Cobra Head")



Figures 5 & 6. Typical Upper Engine Mount, Air Intake Installation

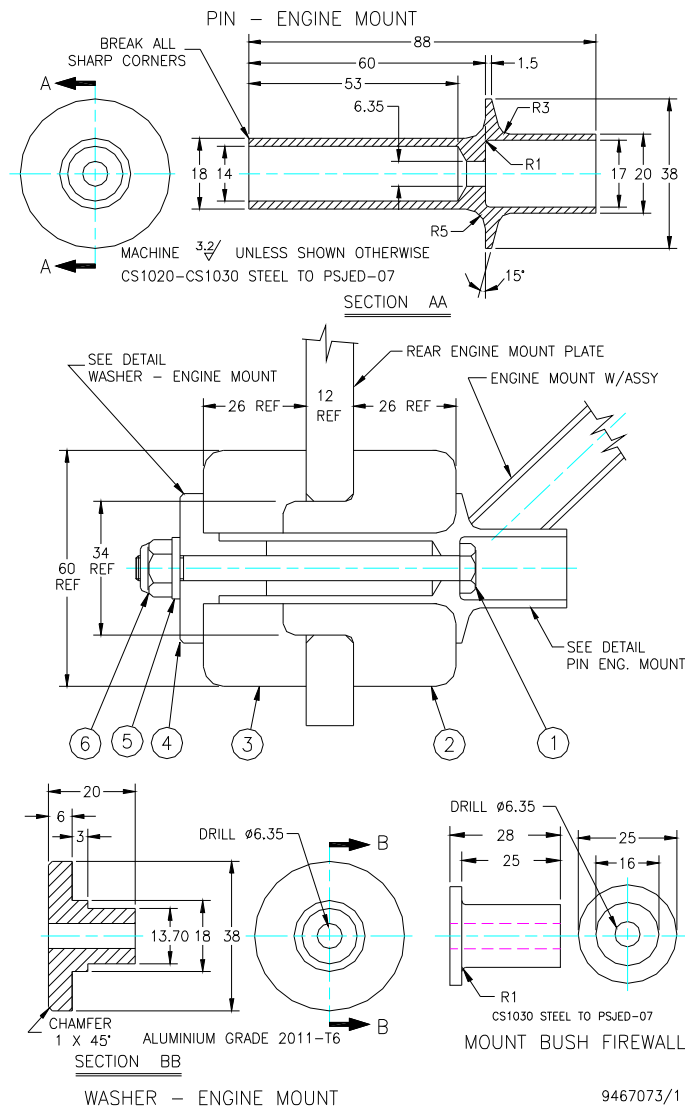

Figure 7 Engine Mount Assembly

3 Controls

This section comprises of the mechanical controls and electrical switches.

3.1 Throttle and Choke

- The throttle and choke cables both attach to the cable mount arm fitted to the carburettor.
- Note: Since a pressure compensating carburettor is used there is no mixture control.
- The cables for the choke and throttle can be adjusted using the adjuster screws and nuts shown in Figure 8. A 7mm spanner is required.
- The cables used must have an adequate radius wherever they turn a corner. Bending the cables too sharply will increase the cable friction, making it difficult to use the control accurately. This is a particular problem for the throttle cable as it will make setting the idle accurately very difficult.
- All Jabiru engines are run-in on a Dynamometer before delivery. It is impossible to accurately set the idle RPM when the engine is on the dynamometer, so the Idle Stop Screw (shown in Figure 8) must be adjusted as a part of the engine installation process.

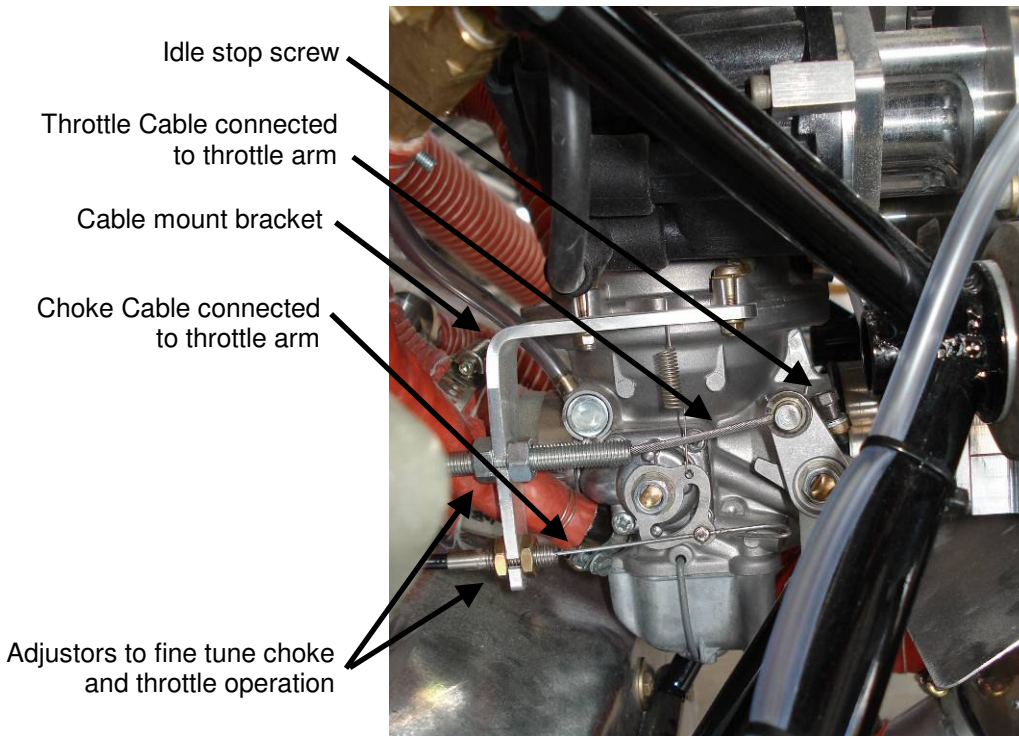

Figure 8. Choke and Throttle Connections to Carburettor

3.2 Ignition & Starter Systems

- The only electrical controls for the Jabiru Engine are the ignition switching and the start button.
- The ignition switches and starter system wiring are connected as shown by the circuit diagram, Figure 27.
- Section 5 gives details of the electrical systems for the engine.

4 Engine Crankcase Breather, Catch Bottle & Dipstick

- The Jabiru 3300 engine has a crankcase breather connection built into the dipstick housing. This is to be connected as shown in Figure 9 below.
- The catch bottle is designed to catch most oil vapour from the crankcase breather air. It must be monitored in service and periodically emptied of waste oil.
- Figure 58 shows more clearly the outlet from the catch bottle – the catch bottle outlet is secured in the cowl outlet. The position of this outlet and the catch bottle itself must be assessed and oriented so that the crankcase of the engine is exposed to pressure close to ambient. If the breather is open to a high or low pressure (partial vacuum) area the pressure inside the crankcases will also change, with unpredictable effects on engine oil consumption, and oil flow within the engine. This is because several areas of the engine are lubricated via low pressure or spray oil feeds, and drained by gravity – pressure differences cause airflow changes, and modified airflow can significantly affect the oil feeds in these areas.
- When installed in a tail-dragger aircraft, re-calibration of the dipstick will be required by the owner so that it can be read accurately with the aircraft sitting on it's wheels.

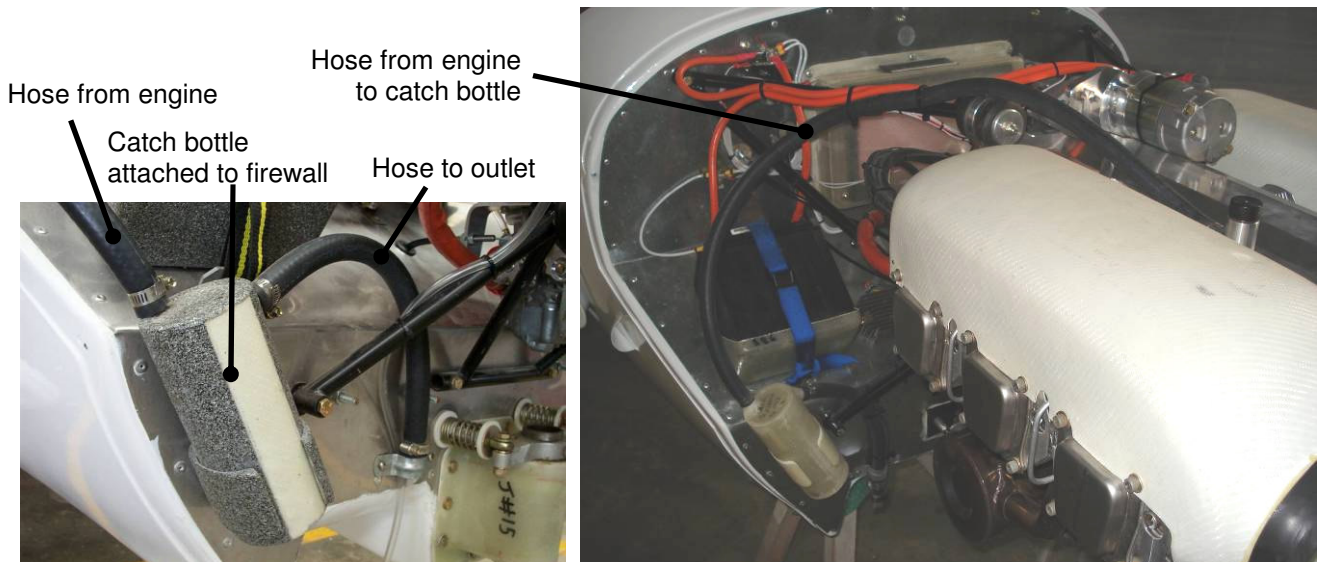

Figure 9. Crankcase Breather Installation

5 Electrical Equipment

5.1 Alternator

- The alternator fitted to the Jabiru 3300 engine is a single phase, permanently excited with a regulator.
- The rotor is mounted on the flywheel and the stator is mounted on the alternator mount plate at the back of the engine. The alternator mount plate is also the mount for the ignition coils and the vacuum pump.
- Note: The electrical system is Negative Earth

Specifications

Power (Max): 200W Continuous



Wire to ignition switch

Ignition coil (1 of 2)

Alternator rotor –
mounted on flywheel

Alternator stator –
mounted on alternator
mount plate fixed to rear
of engine.

Ignition magnets –
mounted on flywheel

Figure 10. Ignition & Alternator Detail

5.2 Regulator

- The regulator has been selected to match the voltage and current of the integral alternator. Only Jabiru Part No. PI10652N should be used. (The regulator output voltage is 14 volts + 0.8 volt.).
- Recommended wiring of regulator is positive and negative of the regulator directly to the battery. A 20A fuse or circuit breaker may be used between the regulator & battery
- The regulator is equipped to illuminate a Low Voltage Warning Light. Refer to Figure 12 for plug pin details.

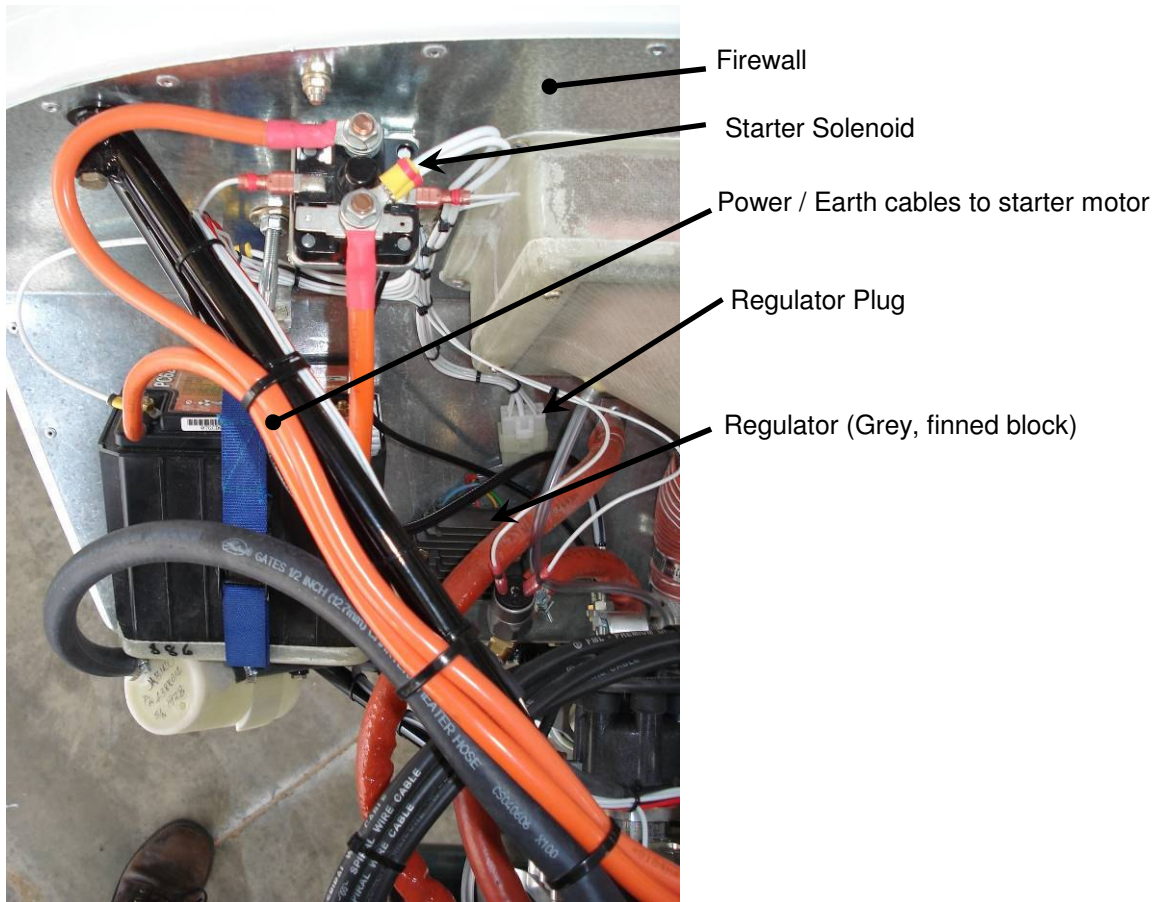
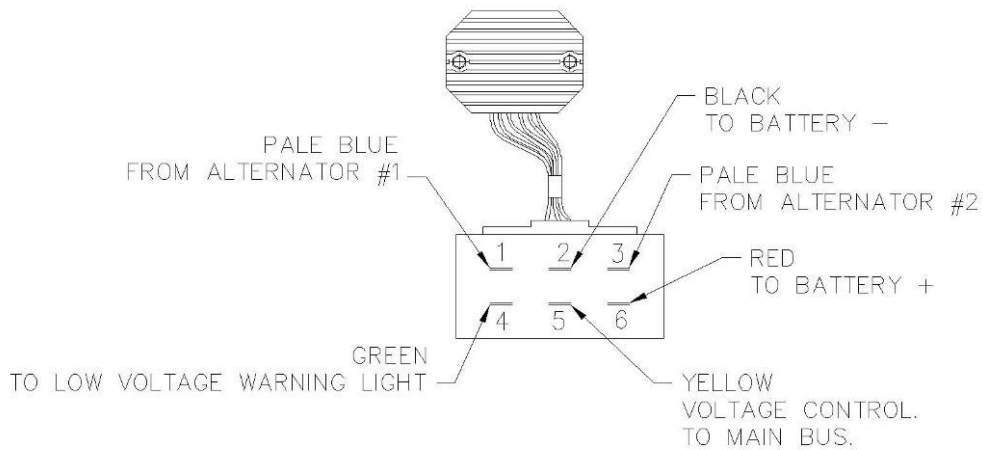

Figure 11. Electrics Installation to Firewall



REGULATOR PLUG WIRING

Figure 12. Regulator Plug Wiring Details

5.3 Ignition

- The ignition unit is a dual breakerless transistorised ignition with the magnets mounted on the flywheel and the coils mounted on the alternator mount plate. Figure 10 shows the coils of a Jabiru 6-cylinder engine.
- The current from the coils flows to the distributor from where it is distributed to the spark plugs.

- The ignition is turned OFF by grounding the coils via the ignition switches. This is the reverse of most electrical systems: when the ignition switch is in the open (not connected) position the coil is LIVE and will fire. Wiring details are shown in Figure 26.
- The ignition is timed to 25° BTDC. Ignition timing is fixed – it is set by the position of the flywheel magnets relative to the crankshaft.
- The temperature limit for the ignition coils is approximately 70°C. This should be checked by the installer. It is recommended that pipes of 12mm dia be fitted to the top rear of each air duct directing air onto the coils for cooling purposes.
- Coil gaps are set at 0.25mm to 0.30mm (0.010" to 0.012").
- When installing new ignition coils the output leads go in the direction of prop rotation. RHS coil output lead is up LHS coil output lead goes down – See Figure 10.

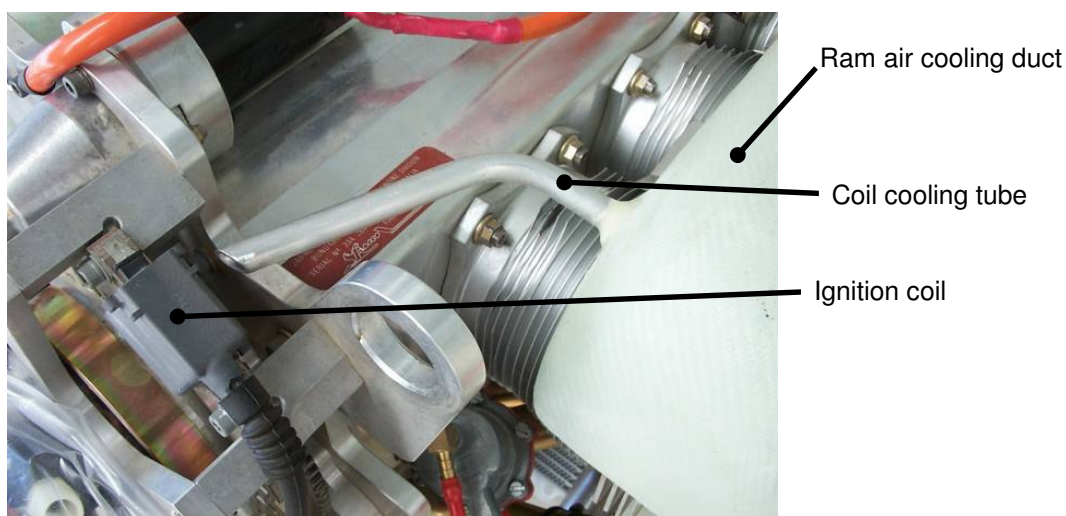

Figure 13. Ignition Coil Cooling Tube

5.4 Starter Motor

- The starter is mounted on the top of the engine and drives the ring gear on the flywheel.
- The motor is activated by engaging the starter button (the master switch has to be ON) which trips the solenoid, hence current flows from the battery to the motor.
- The cable from Battery to starter should be minimum 16mm² copper.
- Wiring details are shown in Figure 26.

5.5 Starter Solenoid

- The starter Solenoid is mounted on the firewall as shown in Figure 11.
- The Solenoid body forms a part of the electrical circuit and MUST be earthed to function correctly.

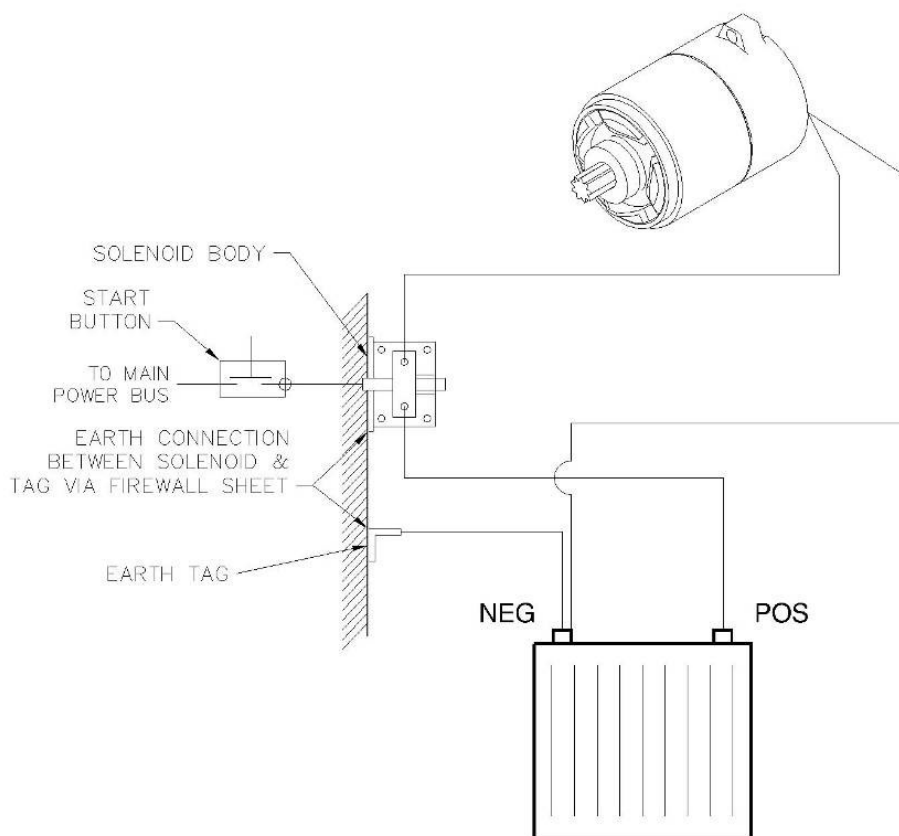

Figure 14. Starter Wiring Details

5.6 Battery

- The battery should be of a light weight, 12V, 20 Ah type able to accept a charging voltage up to 14 V (+ 0.8V) and a 30 AMP Input.
- For optimum starting the battery used must have a high Cranking Amp Capacity (also known as Pulse Amp Capacity). The standard battery used by Jabiru Aircraft has a Pulse Amp rating of 625 Amps. Batteries with higher Pulse Amp ratings may be used and will improve engine starting in colder climates.

5.7 Wiring Practices

- Using aircraft grade wiring is strongly recommended. Compared to other grades of wire aircraft grade can carry higher currents for the same physical size and weight. The insulation used on aircraft grade wire is also flame resistant and is designed for better resistance to damage caused by chaffing or rubbing.
- Care should be taken to identify each wire via labels or similar. This makes troubleshooting electrical issues much easier.
- Wherever possible wires should be identified as carrying "Power" or "Earth". This can be done by using different colour connectors or applying rings of coloured heat-shrink during assembly. Again, this step simplifies troubleshooting or later modification.
- Wires should be laid out in bundles and supported along their length to prevent failures due to fatigue.

5.8 Instruments

5.8.1 Electronic Tachometer

- General wiring information for the Tachometer is given in the Wiring Diagram, Figure 26. Detailed instructions on it's installation are supplied by the instrument manufacturer.
- The tachometer picks up on 2 metal tabs attached to the inside of the flywheel.
- The Pickup used is a Magnetic Induction sender type. It is a passive device requiring no external power.
- They Pickup outputs a voltage in response to variations in their self-induced magnetic field caused by proximity to moving ferrous metal parts (such as the tags fitted to the rear of the flywheel).
- The Tachometer sender must be adjusted to have approximately a 0.4mm gap between the tip of the sender and the tag. Note that due to normal bearing clearances the crankshaft moves slightly when the engine is running, so if this gap is set too small the sender will hit the tag. The sender is fragile and most times damage like this means that the sender must be replaced. If the gap is different for each of the two tags then one tag can be carefully bent to be the same as the other.
- Ensure gauge is reading correctly. While large errors will be obvious, smaller errors are harder to pick and it is recommended to check the gauge reading with another instrument (such as a hand-held optical prop-tach).

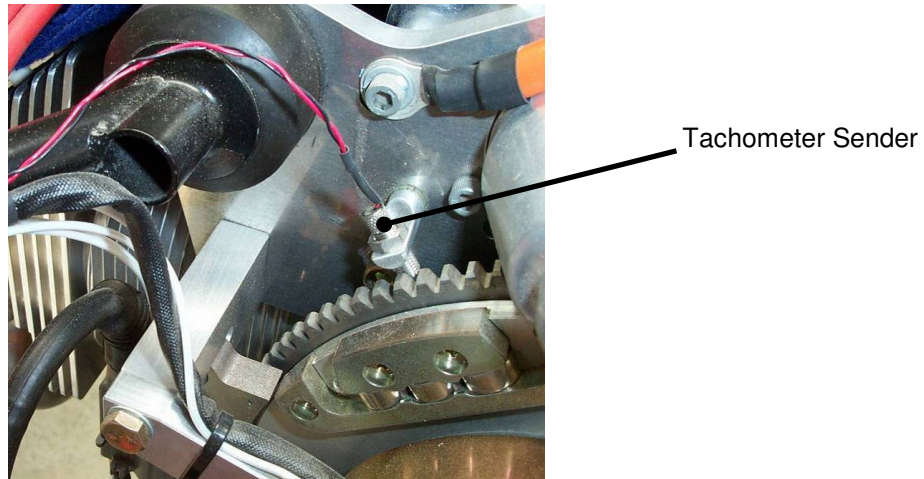

Figure 15. Tachometer Sender Installation

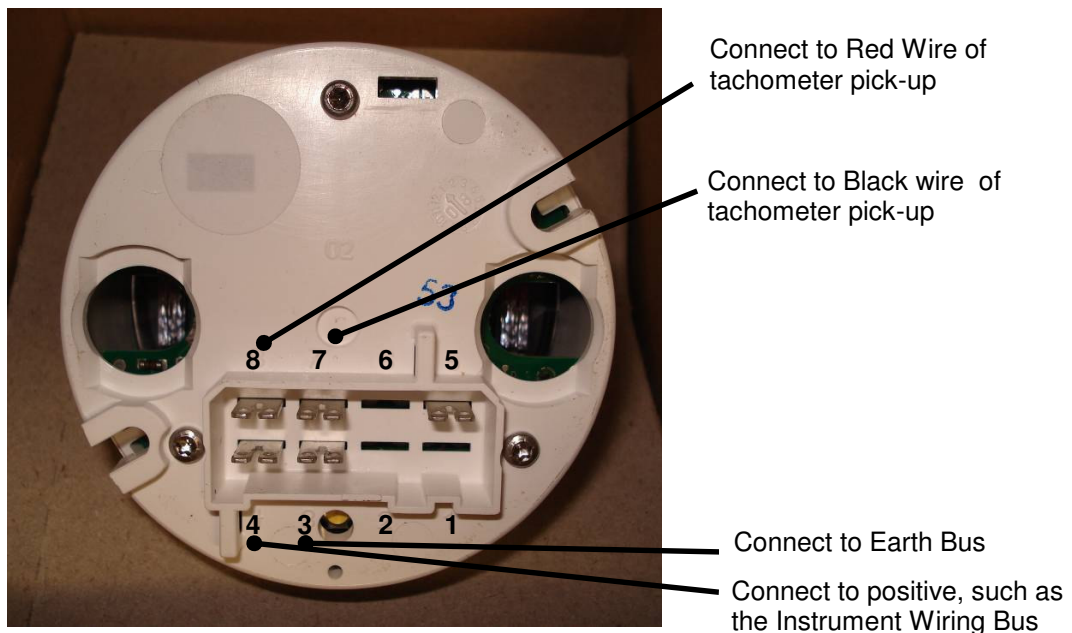

Figure 16. Tachometer Connections

5.8.2 Oil Temperature Gauge

- The Oil Temperature Gauge uses an electric probe mounted in the base of the sump. Jabiru Part No. PI10752N is recommended.
- The gauge has 3 pins, one marked “+” – which is connected to power, one “S” – which is connected to the sensor and one un-marked – which is connected to earth.
- The temperature sender is a brass fitting installed in the engine sump beside the drain plug.
- The oil temperature relies on a good earth connection between the sensor, the engine and the airframe earth terminal. If there is excess resistance at any of these points gauge reading errors will occur.

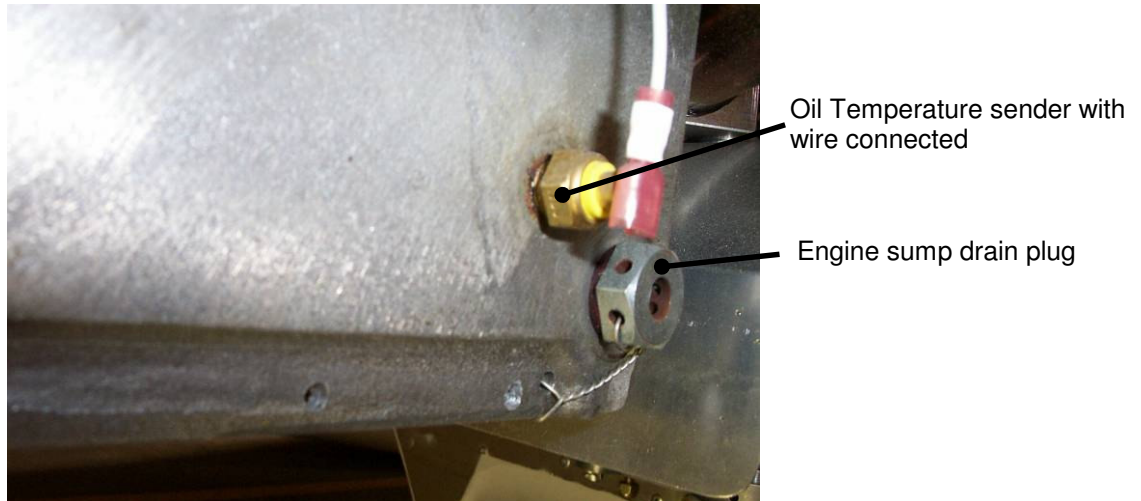

Figure 17. Oil Temperature Sender



Figure 18. Oil Temperature Connections

5.8.3 Oil Pressure Gauge

- An electric oil pressure sender is fitted to the engine for an Oil Pressure Gauge. Jabiru Part No. P110762N is the recommended gauge.
- The gauge has 3 pins, one marked “+” – which is connected to power, one “S” – which is connected to the sensor and one un-marked – which is connected to earth.

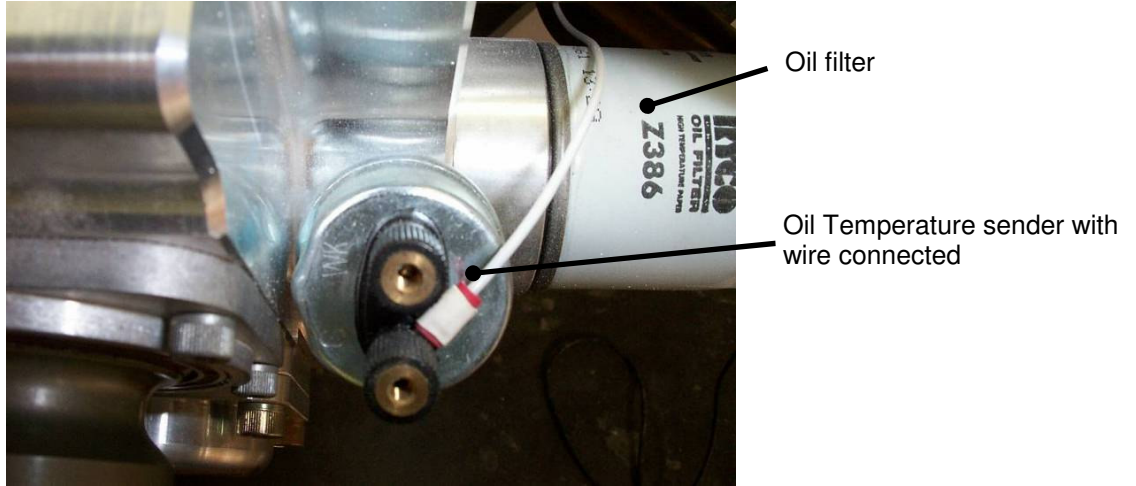

Figure 19. Oil Pressure Sender

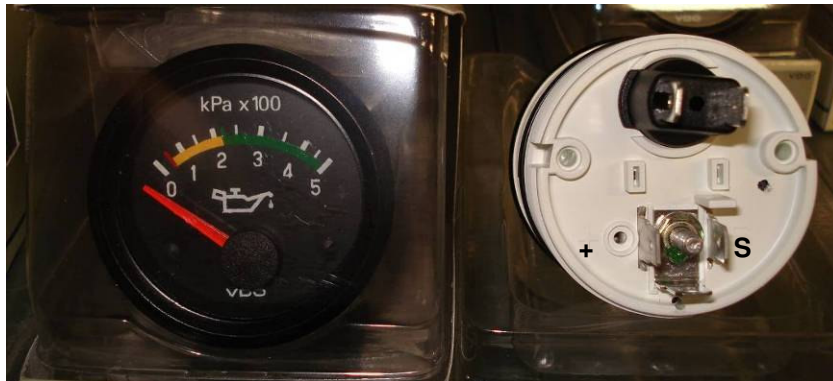

Figure 20. Oil Pressure Connections

5.8.4 Voltage Gauge (Optional)

- A voltage gauge can be connected to the aircraft systems.
- The gauge has 2 pins, one marked “+” – which is connected to power and one un-marked – which is connected to earth.



Figure 21. Voltage Gauge Connections

5.8.5 Cylinder Head Temperature Gauge

- The Cylinder Head Temperature Gauge uses a thermocouple which is installed to the exhaust spark plug of the hottest cylinder of the engine.
- The head temperatures of air cooled engines are typically quite variable – differences of 50°C (90°F) between the hottest and coolest head are not uncommon. Refer to Section 13 for additional information on cooling.
- For a new installation an audit must be done to establish which is the hottest cylinder. The CHT thermocouple probe is then fitted under the exhaust spark plug on that cylinder. Cylinder number 4 often runs hottest in normal tractor installations, however for new installations this **MUST** be checked and confirmed. Jabiru Part No. PI10732N is the recommended gauge.
- Care must be taken when installing the spark plug terminal – the terminal must be aligned with the spark plug. If the terminal is not aligned the spark plug seal will be poor and hot combustion gasses can leak out. These very hot gases will cause the thermocouple to mis-read and show high CHT's. Figure 23 shows properly and improperly fitted CHT terminals.
- Loom and Thermocouple sensor are supplied with the instrument. These must be installed as per the instrument manufacturer's directions. If cable is too long it must be looped as many times as necessary and strapped behind the instrument panel.

DO NOT CUT TO LENGTH

The Thermocouple sensor works by reading small voltages generated by the sensor wires, and cutting the wire upsets the instrument's calibration.

- Ensure that wire is not chaffing on the fibreglass air duct or cooling fins.
- No power connection is required – the instrument reads directly off the voltage created by the thermocouple wire.
- Temperature of the cold junction for best results should be around 50°C. Ensure cold junction is mounted as far from the thermo couple probe as possible.

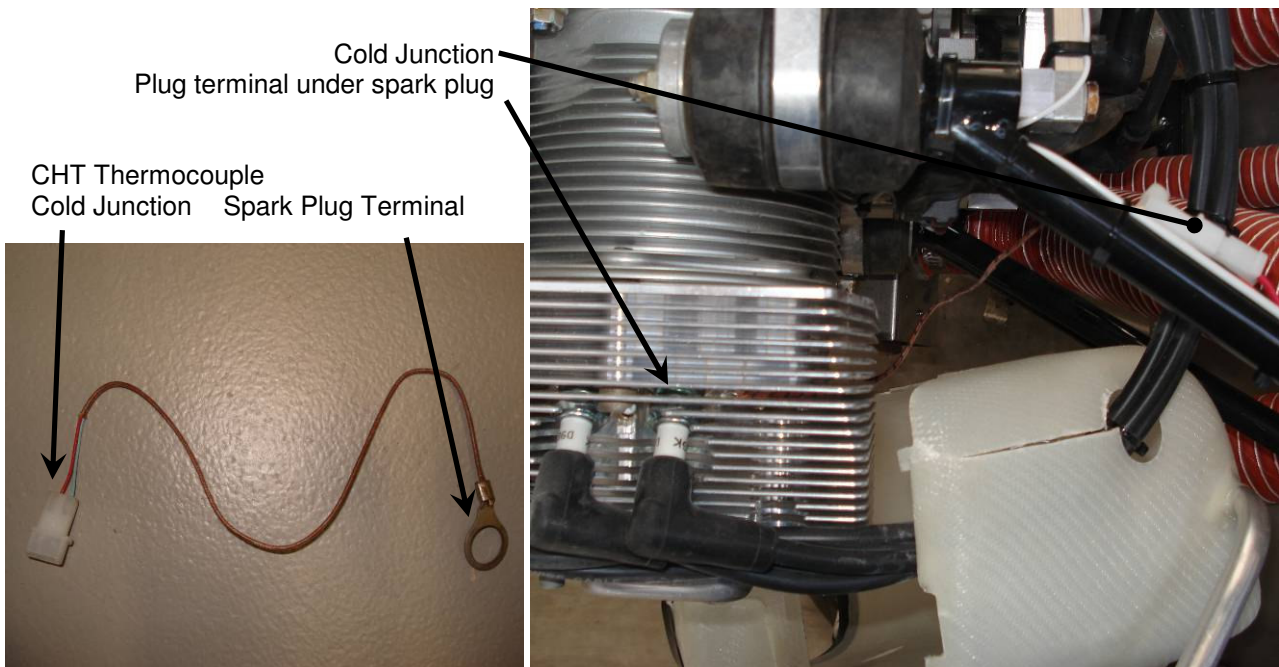

Figure 22. CHT Sender (Thermocouple) Installation

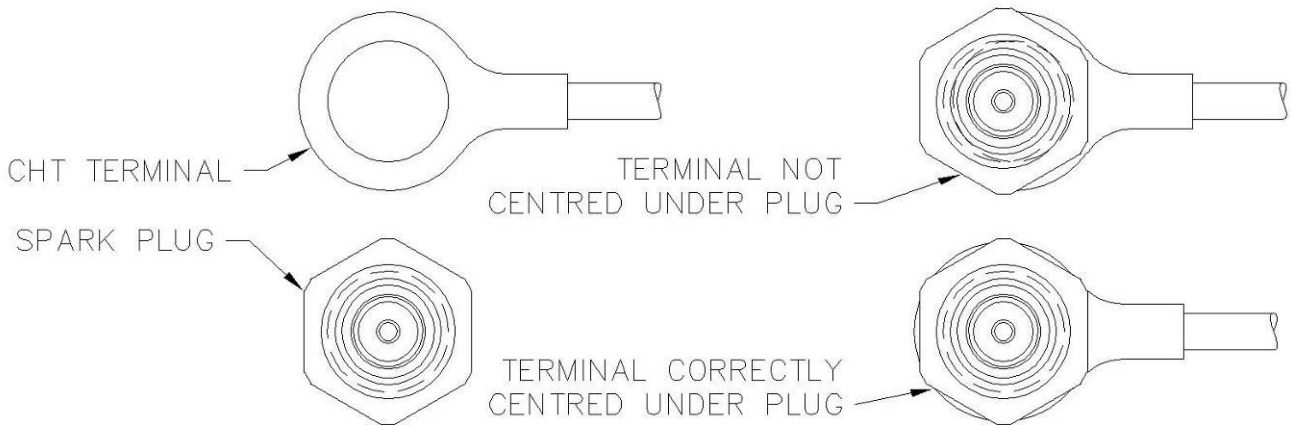

Figure 23. CHT Terminal Installation



Figure 24. CHT Gauge Connections

5.8.6 Exhaust Gas Temperature Gauge

- An optional Exhaust Gas Temperature Gauge can be fitted. The probe should be positioned 100mm from the port flange on the exhaust pipe of a convenient cylinder. Jabiru Part No. PI0325N is the recommended gauge.

5.9 Radio Frequency (RF) Noise Reduction

- RF noise is a common problem with aircraft. Symptoms include:
 - Radio squelch setting needs to be high
 - Excess noise in the background during transmissions
 - Squeals or other feedback noises heard during transmission
 - Intermittent static or noise breaking through the squelch.
- RF noise is a complex problem and is influenced by many different factors. The following points do not contain everything there is to know about RF noise, but they are given as recommendations of general good practice to minimise it's effect.
- Ensure all connections, particularly engine earths, are clean and un-corroded.
- If the aircraft has a metallic firewall it can be used as a shield to block the majority of RF noise. To be most effective any wire that passes through the firewall should be fitted with a Ferrite Bead (also known as a Suppressor or RF Suppressor). Bundles of wires can have a single large Suppressor fitted rather than a

Suppressor for each wire. The wiring diagram in Figure 26 shows suppressors in schematic form. These suppressors are readily available at local electronics stores.

- A Noise Filter can be fitted to the radio’s power supply. Again, these filters are readily available from local electronics stores. The manufacturer’s instructions must be followed for installation.
- Cables passing through the firewall (such as throttle cables, choke, carburettor heat and cabin heat cables) can transmit RF noise back into the cabin. This can be minimised by earthing the cables at ONE end. On the Jabiru Engine an earth wire (Shown in Figure 27) is provided connecting the carburettor to the rest of the engine, so the throttle and choke cables are connected to earth through this wire.
- It is normal & unavoidable that the engine’s ignition system produces some RF noise. This can be minimised by:
 - i. Ensuring all spark plug gaps are set properly.
 - ii. Ensure ignition coil gaps are set properly
 - iii. Ensure all high-tension leads (Spark plug leads) are firmly fitted at both ends – to the spark plug and to the distributor. In addition, the lead from each ignition coil to the distributor must be firmly fitted to the distributor.
 - iv. Ensure Distributor caps and rotors are in good condition.
- To counteract RF noise, Jabiru Aircraft run shielded wiring on all radio and intercom wiring. In our experience, the “Earth Return” method of shielding (where the shield for the wire is also used to form the earth connection) does not work as well as the “Faraday Cage” (where the shield is a shield only – it is not a part of the circuit) method of shielding
- “Earth Loops” – where a wire is connected to earth at both ends – can introduce RF noise into the system. All shields should be connected to the aircraft’s earth system at one end only.
- The cable used for the Antenna should be high quality, such as RG400 (Shown in Figure 25). This cable has a double layer of shielding and better RF insulation than other cable types. Note that the coaxial cable included in most antenna kits tends to have a single layer of insulation. BNC connectors are recommended for most applications, and wherever possible crimped connectors which require a special crimper to assemble should be used. Crimped connectors are much less prone to RF leakage or assembly issues than other types (such as screw-together BNC connectors).
- Wires and antenna cables must be routed carefully. Bending or coiling Co-axial cable (such as is used for antennas) sharply will significantly degrade the cable’s RF shielding and must be avoided wherever possible. Coiling antenna cables or any wire carrying current (sensor wires carry very low current so are generally exempt from this requirement) into loops can induce RF noise in other systems. GPS antennas in particular are powered – both the antenna and any excess antenna cable must be positioned carefully, as far away from the radios, antennas and intercom as possible.
- While not a part of the engine installation, strobes can produce significant RF noise. Most brands of strobes require that the box containing the strobe head unit electronics is earthed, and this is essential to minimise noise. The cables used for the strobe lights themselves must be shielded and the shield must be earthed properly, at ONE end only. The Box containing the strobe electronics can also be installed on the engine side of the firewall to further reduce RF noise. The strobe unit’s manufacturer normally provides good instructions for minimising their effect on radio noises.

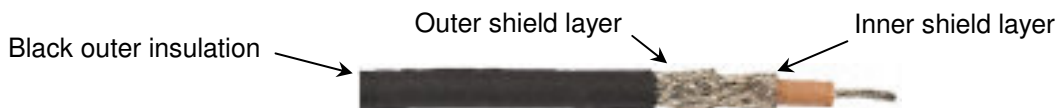

Figure 25. RG400 Co-Axial Antenna Cable

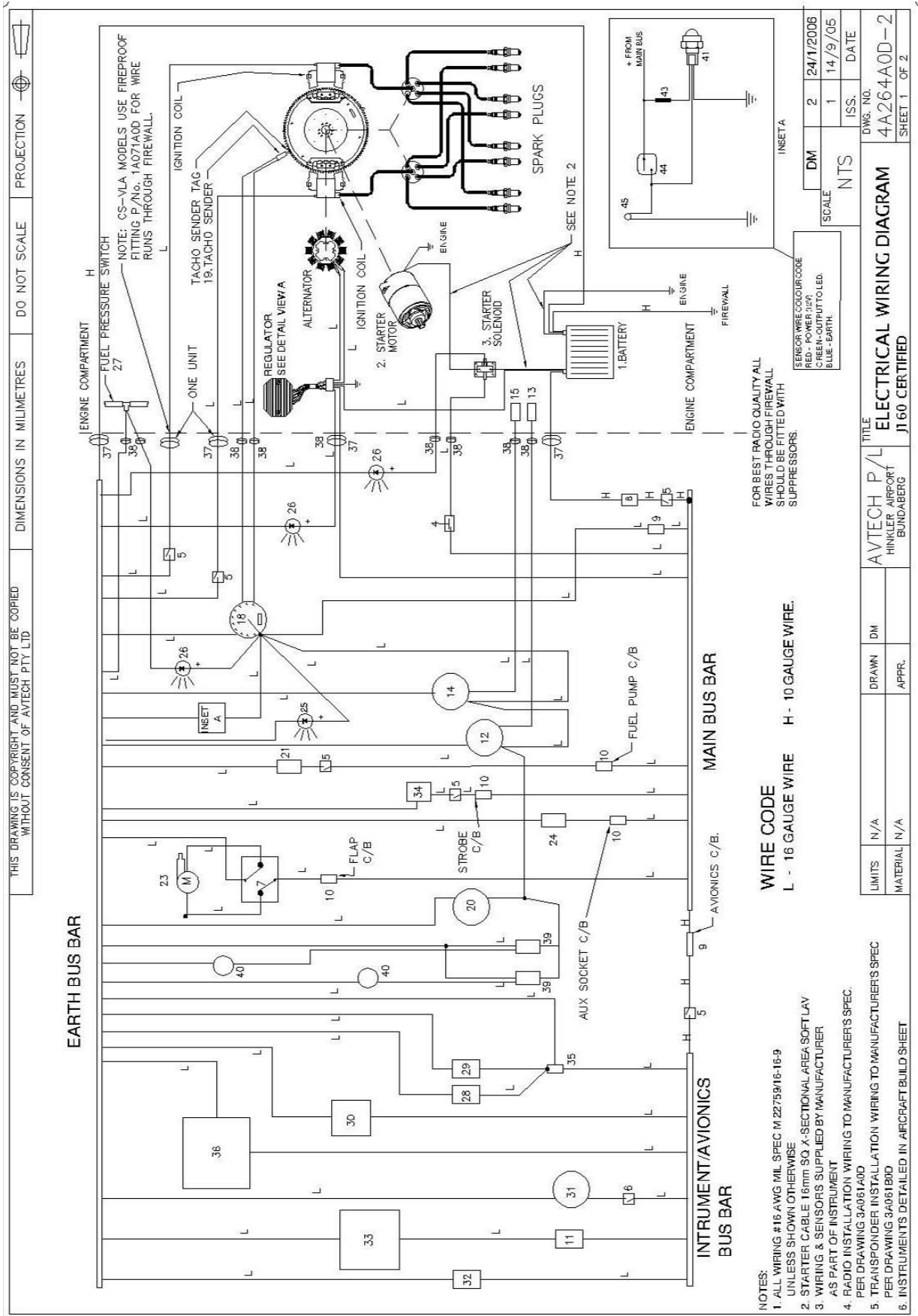

Figure 26. Wiring Diagram

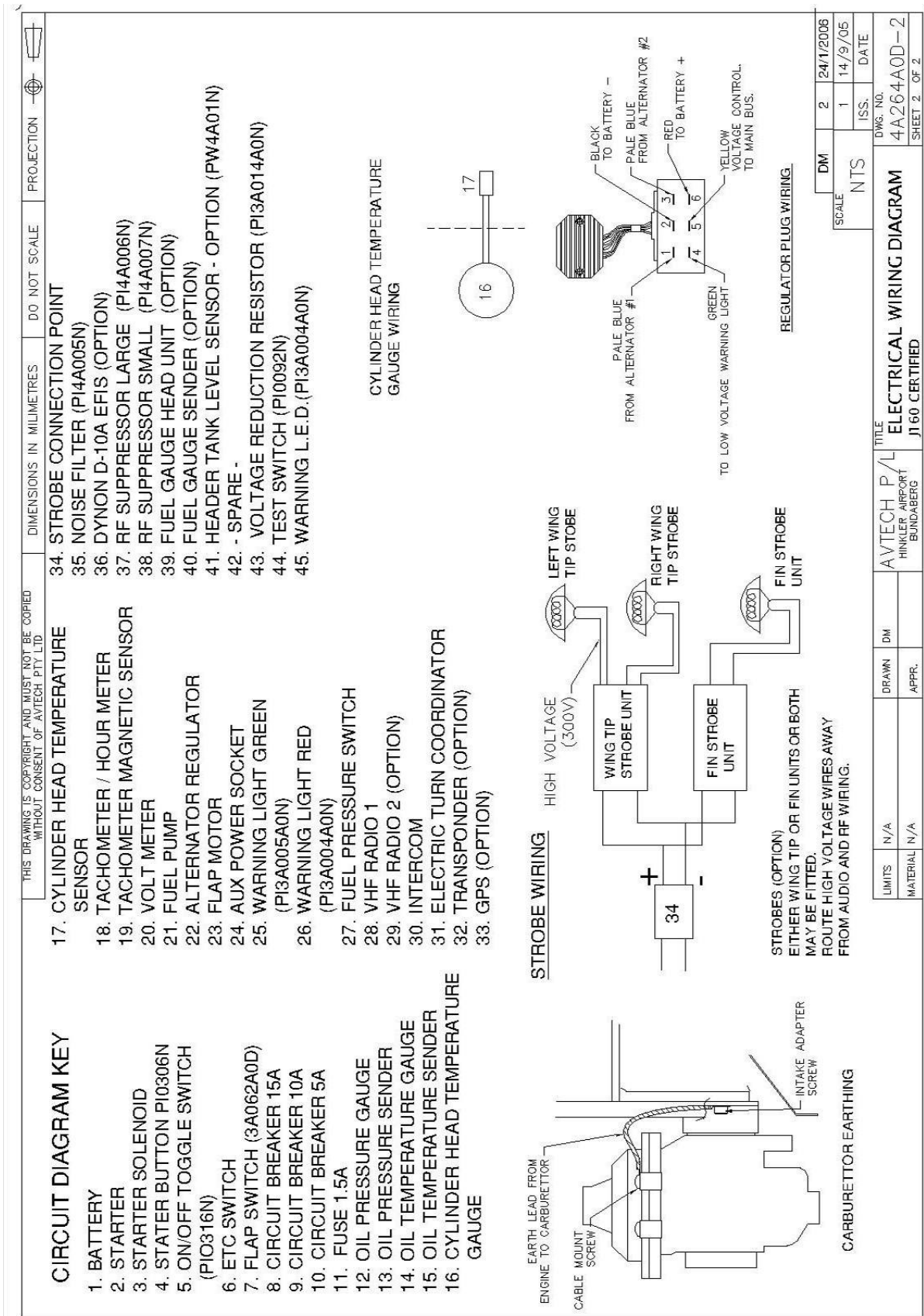

Figure 27. Wiring Diagram Key

6 Fuel Supply System

6.1 Fuel Tank

- The fuel tank must be fitted with an outlet strainer of between 8 and 16 mesh per inch, with a minimum total mesh area of 5 cm².
- Ensure the fuel tank is properly vented.

6.2 Fuel Filtration

- A Fuel filter capable of preventing the passage of particles larger than 0.1mm (100um) must be installed between the fuel tank outlet and the fuel pump.
- The filter must be present in the system for the fuel flow test. The size of the filter should give consideration to allow adequate flow with a used filter.
- A Ryco Z15 disposable paper element automotive filter has been used successfully. Note that this filter, or any other filter with a plastic body must not be used on the engine side of the firewall – regulations and common sense both require that all fittings in the fuel system on the engine side of the firewall must be fire resistant.

6.3 Mechanical Fuel Pump

- The mechanical fuel pump is mounted on the engine crankcase and is camshaft driven. It is designed to supply fuel at the pressure described in the following paragraph.
- Many airworthiness categories require that a backup fuel pump be fitted in case the primary pump fails. Jabiru Aircraft recommend fitting an electrical boost pump. If fitted, this pump must also fulfil the fuel input criteria for the carburettor, given below.
- Some airworthiness categories also require an additional drip tray be fitted to the fuel pump. This optional tray is shown in Figure 28.

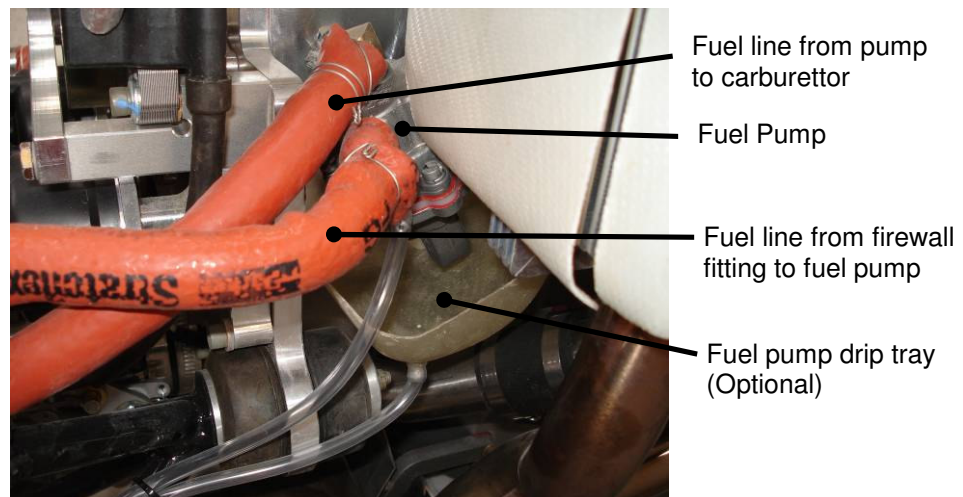

Figure 28. Mechanical Fuel Pump

6.4 Fuel Flow Meters

- Where a Fuel Flow Meter is to be installed to the aircraft Jabiru Aircraft recommend that the flow transducer is not installed on the engine side of the firewall. Most transducers are made of either plastic or light aluminium and are not fire resistant. Regulations and common sense both require that every part of the fuel system on the engine side of the firewall must be fire resistant.

6.5 Carburettor

- A Bing constant depression type 94/40 is used. This carburettor has a minimum delivery pressure of 5 kPa (0.75 Psi) and a maximum pressure of 20 kPa (3 psi). To confirm that the fuel system is capable of delivering this pressure a fuel flow test must be performed.

WARNING

When using auto fuels, the fuel delivery system must be designed to prevent fuel vaporization.

To check pressure, insert a 'T' piece between the mechanical pump & carburettor. Test boost pump with engine off, then mechanical fuel pump with engine on, then combine with electrical boost pump as well, before first flight.

- A method for performing a fuel flow test is available from Jabiru if required. In brief, the fuel line is disconnected from the carburettor, fuel is pumped into a calibrated container and the rate at which the fuel is pumped (or drained, for gravity-fed systems without a pump) is calculated.
- Most regulations require that the fuel system (including pumps) supplying the engine be capable of delivering 1.25 to 1.5 times the maximum flow rate required for the engine. For a Jabiru 3300 engine this equates to approximately 44 to 53 Litres per hour (see Section 1.3.3). The electric boost pump used on Jabiru Aircraft generally manages a flow rate of approximately 60 litres per hour.
- The Bing carburettor has a Balance tube (also known as a "sense tube") which connects the carburettor to the air box. The tube runs from a nipple on the carburettor to the airspace in the air box on the "clean" side of the air filter. This tube is part of a system or ports which "tells" the carburettor how hard the engine is working and controls how the carburettor varies the fuel / air mixture delivered to the engine. Tuning issues and poor running will result if this tube is blocked or connected to the wrong spot. Figure 30 shows the tube installation. Note that the balance tube must not be connected to the air box in a location where the air is moving fast – rapid flows produces pressure changes and boundary layer effects which mean the balance tube gives the carburettor "bad" information, which can cause poor mixture control and running issues.
- A drip deflector to deflect overflowing fuel from the exhaust system is supplied as standard equipment on the engine.
- Because idle adjustments cannot accurately be made on the dynamometer (where every engine is run before delivery), some adjustment of the 7mm idle set screw may be required. A hot idle of around 900RPM is desirable.
- Fitting an earth strap from carby to crankcase is recommended to eliminate possible radio interference.

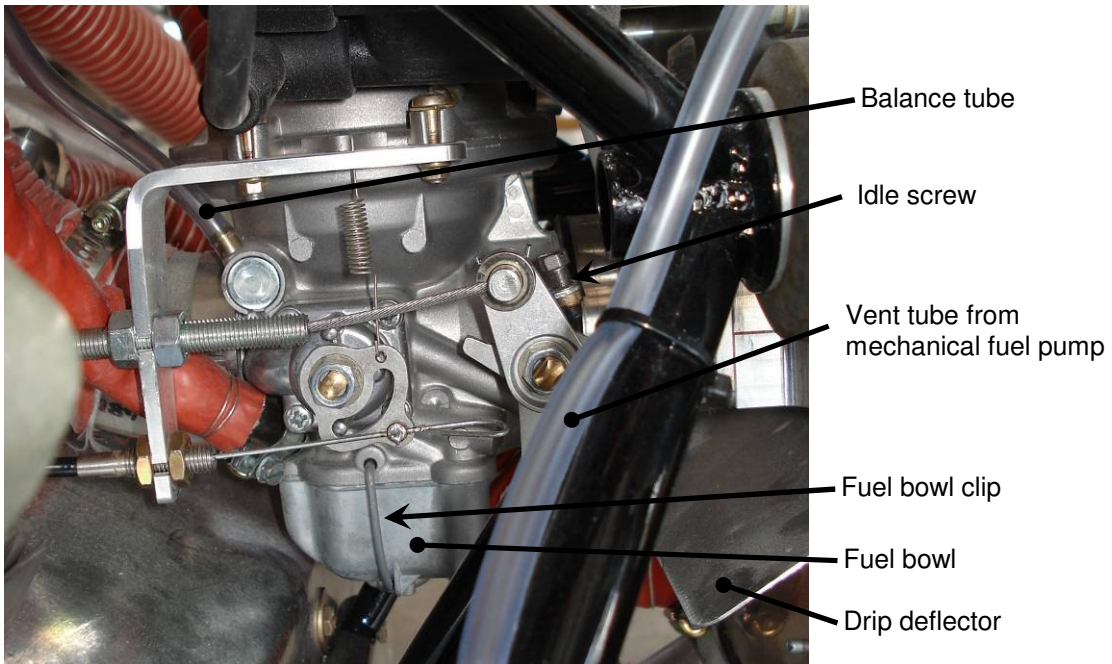

Figure 29. Carburettor Installation

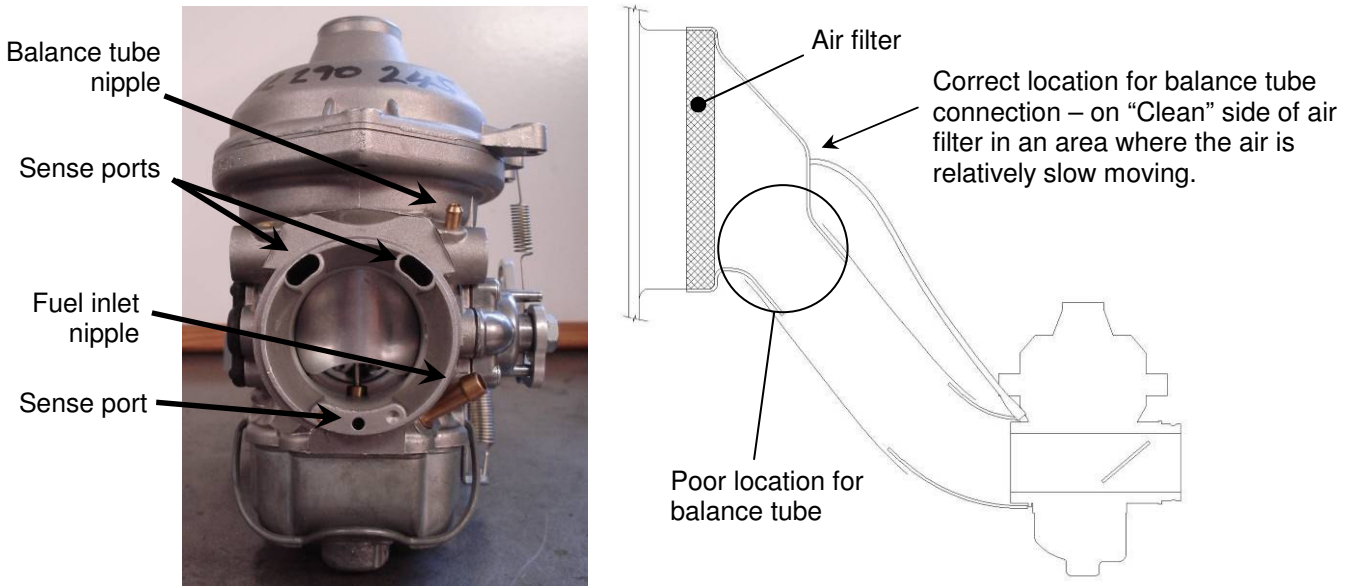

Figure 30. Carburettor Intake & Balance Tube Detail

6.5.1 Carburettor Operation

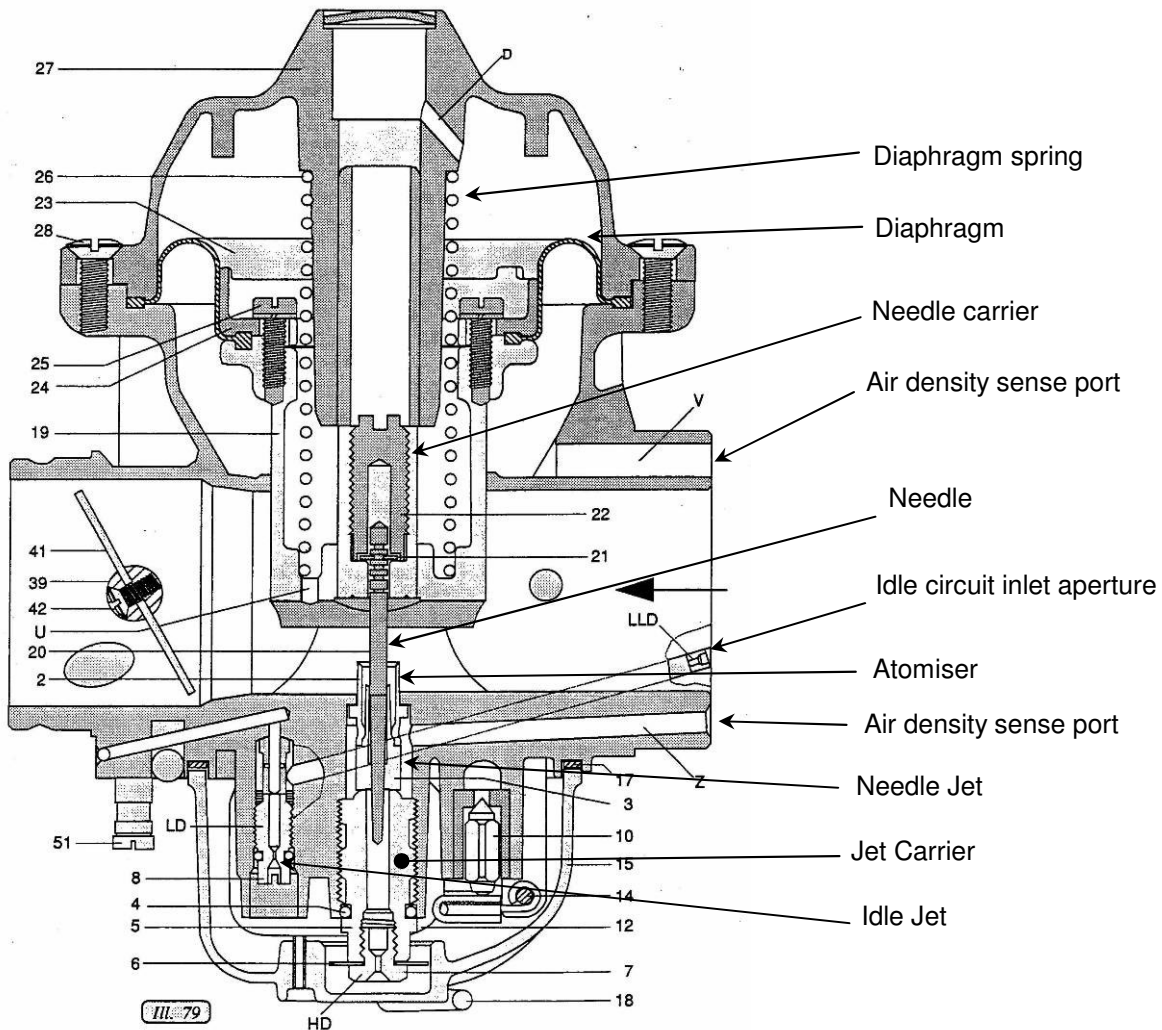

Figure 31. Carburettor Schematic

- The Bing altitude compensating carburettor uses bowl float level and two main air circuits – the idle and the needle/main – to control the mixture. Both circuits use jets to meter the rate at which fuel is allowed to flow. The jets are small brass parts with precisely controlled openings (both the size of the opening and the shape surrounding the opening affect fuel flow rate) which can be changed to adjust engine mixture.
- The main and idle jets have simple fixed apertures, while the effective size of the needle jet aperture varies, depending on the diameter of the needle. Figure 32 below shows three different throttle settings in the needle jet and the corresponding difference in aperture. On the left is a low power setting, where the needle jet is nearly completely blocked by the needle. The middle throttle setting corresponds approximately to a high cruise power setting. The gap between the needle and the sides of the jet is much larger. The final setting corresponds approximately to wide open throttle. The needle jet is now effectively not there, and the amount of fuel flowing is controlled by the main jet (located upstream of the needle jet in this circuit).
- The shape of the taper of the needle controls the mixture at a given throttle setting. The needle used in Jabiru engines been optimized for use with a propeller, which puts a very non-linear load on the engine; to double the RPM of a propeller a lot more than double the power has to be applied.
- To achieve a good mixture with the type of load applied by a propeller, the Jabiru needle uses two-stage taper and a straight tip. The more gradual taper at the upper end of the needle gives a leaner mixture in low-power cruise settings and at lower RPM where the propeller is using relatively little power. The sharper taper at the lower end ramps up rapidly to a much richer mixture at higher power settings. The straight tip of the needle is used when the throttle is wide open and the engine's mixture is being controlled by the main jet. This rich mixture at full power protects the engine from detonation.
- The transition from lean, cruise mixtures to richer full-power mixture will occur at around 2800 – 3000 rpm on 4 and 6 cylinder engines, when fitted with an appropriate propeller. For most efficient operation, the transition must be above cruise rpm. The transition can clearly be seen by changes in the EGT.

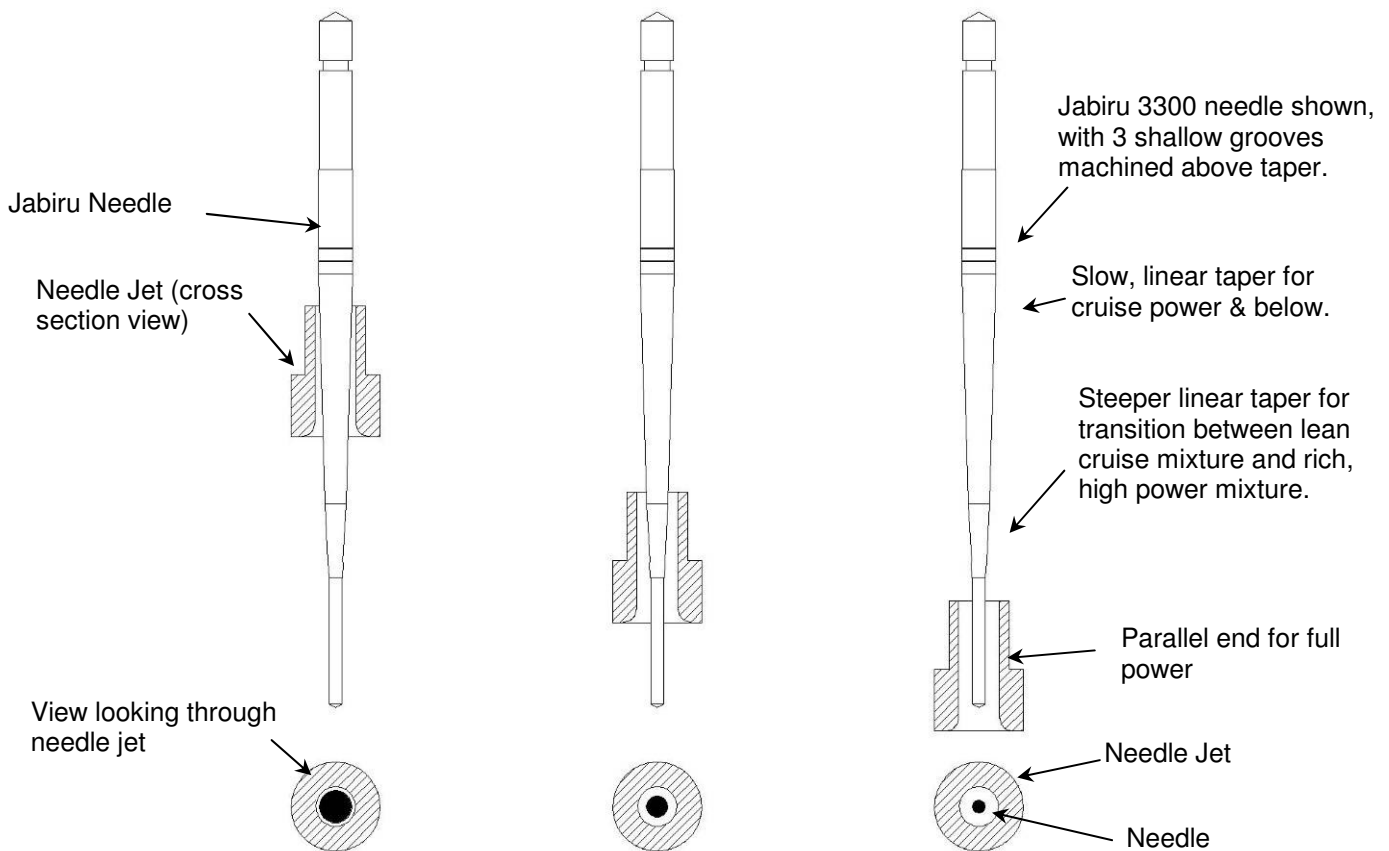

Figure 32. Needle Jet (Jabiru Needle)

- Because of the way the carburettor uses the sense ports and balance tube to regulate the mixture it is sensitive to the way the intake air moves, and to the conditions of the intake system.
- Section 7 below contains information on setting up the induction system.



6.5.2 Carburettor Tuning

- The mixture supplied to the engine by the carburettor is affected by a large number of variables, including:
 - i. Ambient temperature
 - ii. Propeller size (coarse or fine) and loading
 - iii. Whether the engine is cowled or open (by affecting the temperature of the induction pipes and carburettor)
 - iv. The airframe type
 - v. The intake system
- Because of these factors, we recommend that whenever a new engine installation is being developed that the engine be fitted with EGT probes and the tuning checked.
- Jabiru Aircraft or our local representative can provide assistance during this phase.

6.6 Fuel Lines

- Fuel lines are nominally 6mm bore.
- All hoses forward of the firewall require fire resistant sheathing (visible as an orange covering on the fuel lines in Figure 28 above). Note that wherever possible the sheathing should be extended past the hose clamp. The ends of the sheath must be held in place using safety wire to prevent the sheathing moving and exposing the fuel line.
- Fuel lines between moving sections such as between engine and firewall should be flexible. SAE standard automotive rubber hoses are adequate, provided they are protected with fire resistance sheathing.
- In many countries (including Australia) standard airworthiness requirements state that all flexible hoses must be changed every two years, though if there are visible signs of degradation (such as cracking or hardening) the hose should be changed immediately.

7 Air Intake System

7.1 Intake Air Heating

- The Jabiru 3300 engine can experience carburettor icing in some conditions. Jabiru Aircraft strongly recommend that a system for heating engine intake air be included in the induction system design.

7.2 Intake Hose & Air Filter Box

- Jabiru Aircraft recommend that engine intake air be drawn from outside the cowl wherever possible.
- Due to the way the carburettor works (as described above) it is sensitive to the air flowing into it. Turbulence, swirl and sharp edges all affect the mixture metering system of the carburettor.
- The hose type recommended for induction systems is SCAT aircraft type.

WARNING

SKEET type, which has an inner liner must NOT be used. Over time the inner lining can detach and collapse, blocking the hose. SKEET hose should be used for positive pressure applications only.

- Tight corners in the hose (as shown in Figure 33) can introduce both swirl and turbulence to the air flowing into the carburettor
- Connecting the hose directly to the carburettor can cause the hose to bunch up and cover the sense ports. A “Cobra Head” duct or similar is recommended to prevent this.
- Sharp corners inside the air filter box cause turbulence and a pressure drop. The pressure drop means that the carburettor balance tube pressure reading is inaccurate, while the turbulence affects the readings at the carburettor sense ports. Both items can cause power loss and rough running – particularly at high power settings.
- For installations where there is very little room between the carburettor and the firewall a special duct has been developed to minimise pressure drop and turbulence – shown in Figure 37.
- The intake hose should align as closely as possible with the carburettor body – having the intake duct come at the carburettor from one side encourages swirl and can give uneven mixture.

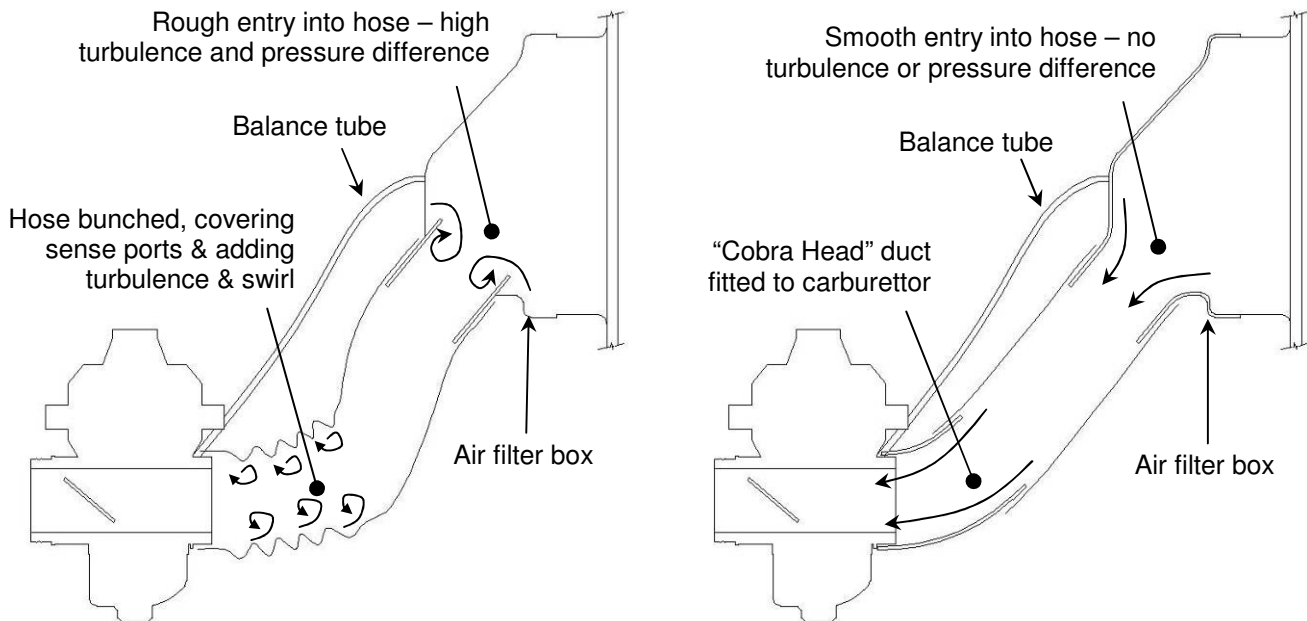

Figure 33. Air Intake Connections



Figure 34. Air Filter Box Plumbing – Incorrect

Correct plumbing – sharp lips & abrupt corners rounded & smoothed off.

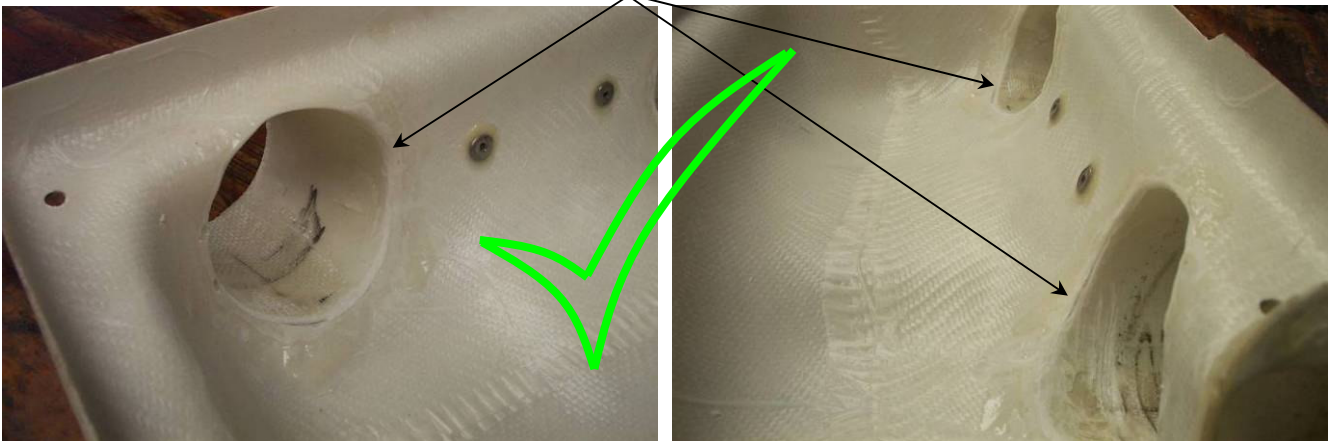
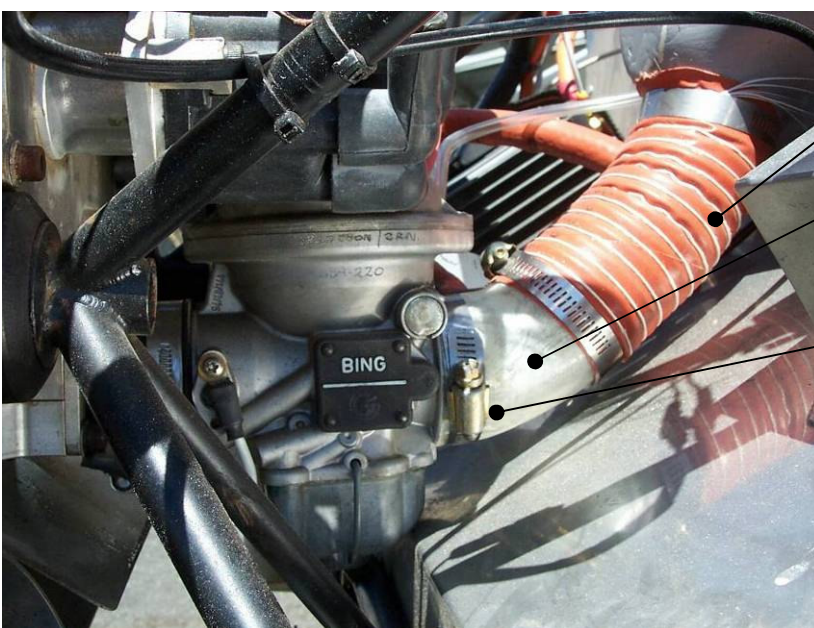

Figure 35. Air Filter Box Plumbing – Correct



Gradual bends only in SCAT hose

Glass “Cobra Head” removes a sharp corner in SCAT tube

Glass duct prevents bunched SCAT hose from blocking sensor holes on carburettor inlet

Figure 36. Typical “Cobra Head” Installation on a Jabiru Aircraft

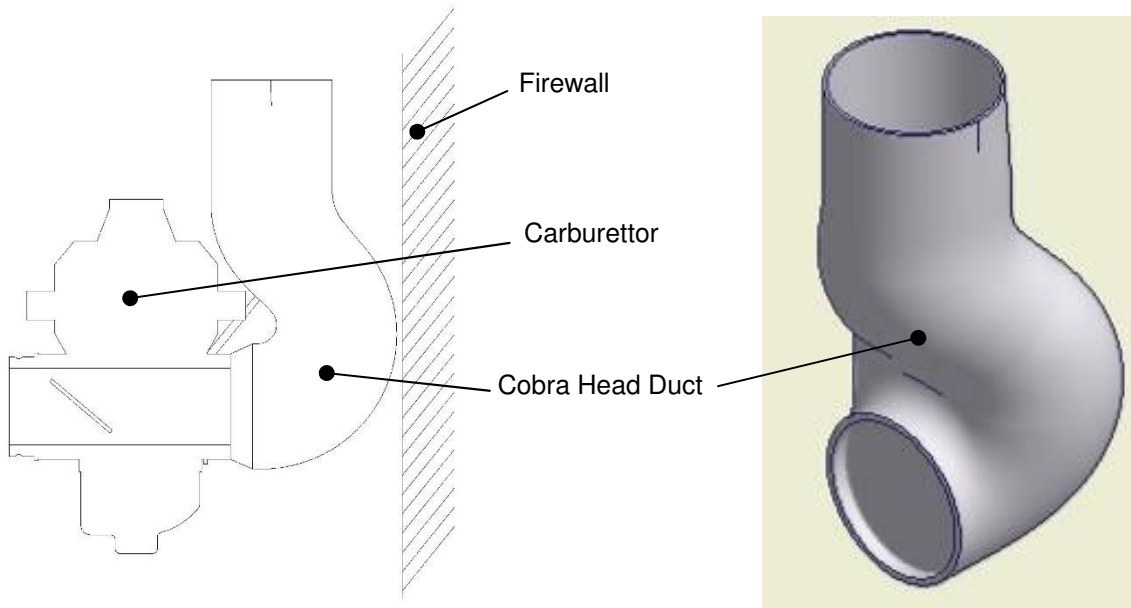

Figure 37. Cobra Head for Installations with Minimum Carburettor Clearance

7.3 Air Filter

- The induction system must not cause positive RAM induction pressure as this will have an unpredictable affect the fuel/air mixture supplied to the engine.
- The filter must be capable of supplying 250 kg/hr (550 pph) of air
- The filter may have to be changed at regular intervals if the engine is to be used in a dusty environment.
- Air flow should be as direct as possible, no tight bends and air taken from outside the cowl. Current air filter is RAF 17 (RepcO)

7.4 Ram Air Bleed

- The hot air mixer box / filter boxes manufactured by Jabiru Aircraft have a Ram Air Bleed flap incorporated.
- This flap prevents excess ram air pressure in the induction system.
- If the engine ever backfires, the flap also acts as a relief valve to let the excess pressure escape without damaging the induction system.

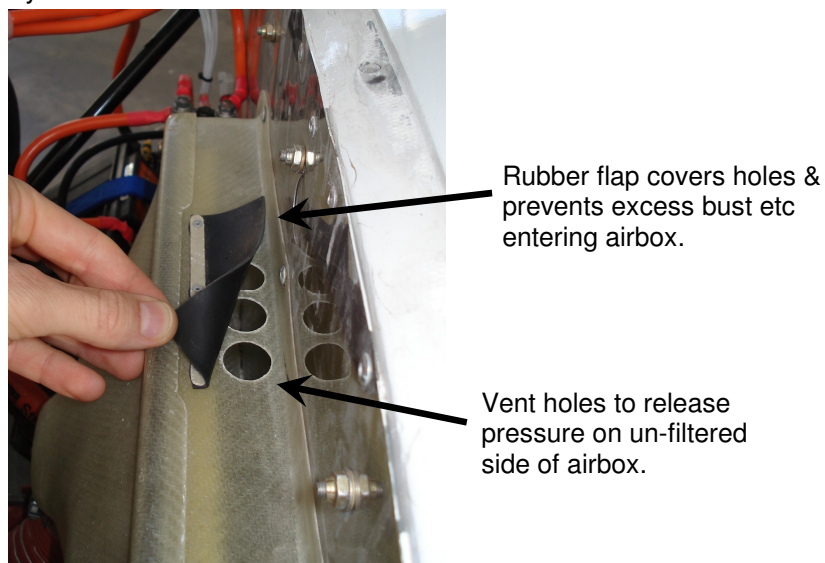

Figure 38. Ram Air Bleed



8 Exhaust System

- An exhaust system is provided with the engine. Both Pusher and Tractor systems are available.
- Muffler Volume – Capacity 5 litres
- Back pressure at Takeoff Performance – Max 0.2 bar (2.9 psi). Readings taken 70mm from muffler flange connections. Only complete mufflers supplied with Jabiru Aircraft are welded – all others require tail pipes to be TIG welded to the muffler body. NOTE: Drilled ends of pipes go inside muffler cavity. The tail pipes go completely through the muffler body and are welded on both top and bottom.
- When fitting the muffler one or more of the exhaust pipes can be loosened at the connection to the cylinder head to allow easy fit of the muffler. They then must be tightened.
- Exhaust Gas Temperature (EGT) limits are given in Section 1.3.7.



9 Propeller & Spinner

- The hub of the propeller must be drilled with holes to match the flange.
- Fixed pitch wooden propellers are preferred. To safely use a propeller made of metal or composite a crankshaft vibration resonance survey has to be conducted to ensure that there are no damaging vibrations. Note that this refers to each new propeller design using composite or metal blades – once proven the propellers do not need to be tested for each individual installation. However, due to their inherent vibration damping qualities, wooden propellers can be used without this testing.
- Wooden propellers require periodic inspections to maintain proper attachment bolt tension – Typically every 50 or 100 hours, depending on the propeller manufacturer’s recommendations.
- Belleville washers may be used as shown in Figure 39 to allow for expansion and contraction of Jabiru wooden propellers.
- The propeller must be carefully selected to match the airframe and the engine: Propellers up to 1778mm (70”) in diameter and between 762mm (30”) and 1397mm (55”) in pitch² may be used. The propeller flange is drilled with two sets of holes which can be used for propeller mounting. 6 holes at both 101.6mm (4”) PCD and 111.12mm (4 3/8”) PCD (total of 12 holes).
- The Jabiru Engine does not have a hydraulic pressure supply or a governor mounting pad required for a hydraulic constant speed or variable propeller.
- Propellers with excess pitch can cause high temperatures and engine damage. Nominally, all propellers must be able to obtain 2800rpm static and 3150rpm to 3300rpm wide open throttle straight and level. However, in some particularly low-drag airframes it may be necessary to use a propeller which does not achieve 2800 static rpm. In these cases propellers should be chosen based on their RPM at wide open throttle (straight and level flight).
- Do not cruise or climb in the range 2100rpm – 2400rpm.
- Maximum moment of inertia 0.3 kgm²
- Applications outside this range should be referred to Jabiru.

WARNING

Engine MUST NEVER BE RUN WITHOUT THE PROPELLER. Damage will occur in this state.

² Pitch measurements are taken from the angle of the rear face of the prop blade. Other propeller manufacturers may specify pitch measured from the blade mean chord line or other reference. Make sure you are comparing equivalent pitch units when specifying a propeller.

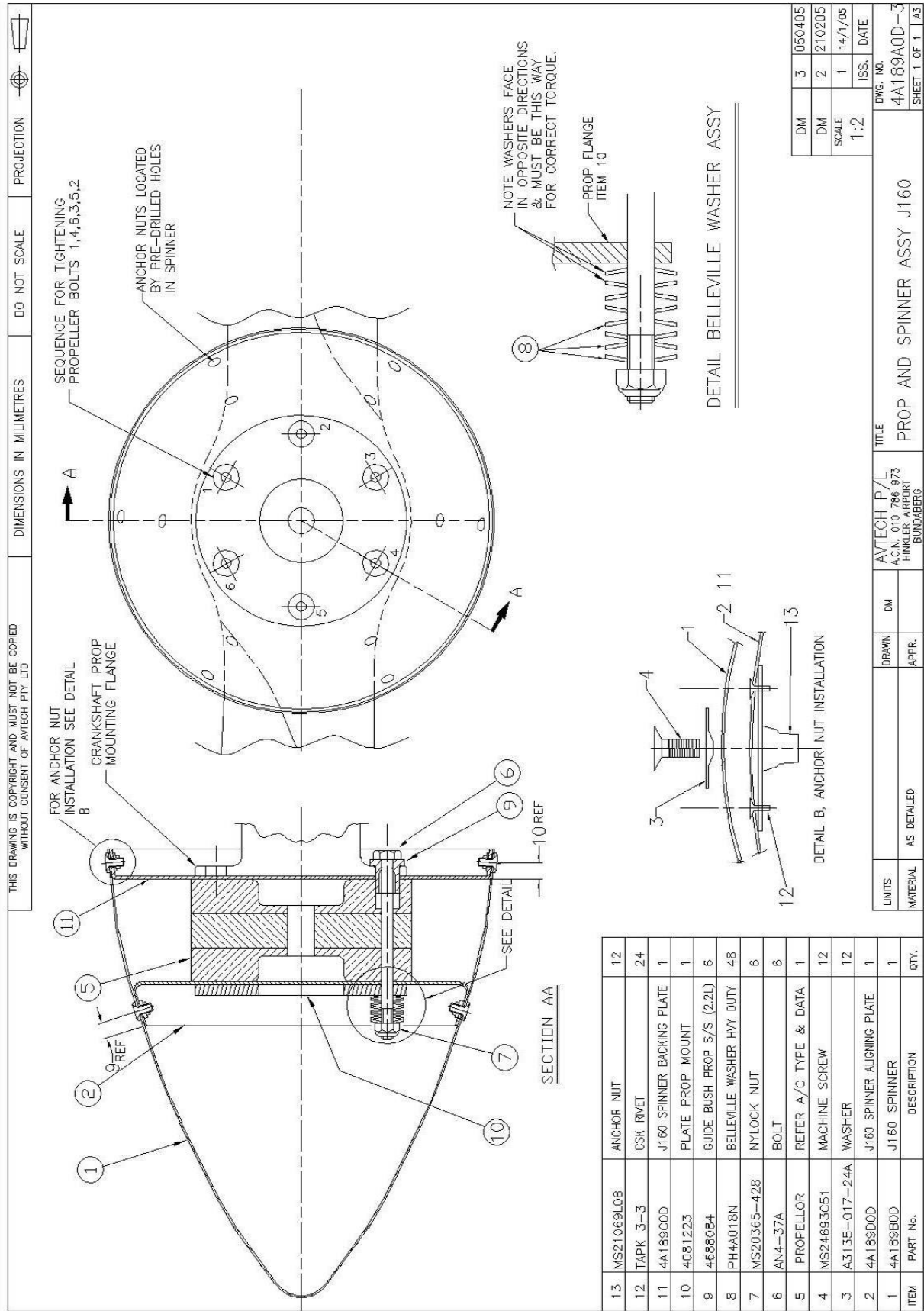

Figure 39. Jabiru Propeller & Spinner Installation



10 Engine Installation Procedure

- Attach male engine mount rubbers to all engine mount pins on the engine mount. Place an AN4-31A bolt through each mount. Note that an engine mount spacer washer is fitted between the male rubber & the lower engine mount pins (Refer to Figure 42 below).
- With the Back of the Aircraft Supported & the wheels chocked, lift the engine onto the engine mount.
- Insert the upper engine mount rubbers into the engine backing plate first by tilting the front of the engine up. Once both upper rubbers are through the engine backing plate, fit the female rubber, engine mount spacer washer, engine mount washer, 1/4" washer & Heat Proof nut.
- To place the nuts on the mount bolts the rubbers must be compressed. Do this by using a deep reach socket inside the engine mount pins & clamping the rubber mount assembly using a G-clamp with the swivel taken off the ball. See Figure 41. Start nuts on both upper mount bolts.
- Once bolts of the upper rubbers are started, continue lowering the front of the engine & align the lower engine mount pins with the engine backing plate.
- Use the weight of the engine to compress the lower rubbers & fit the nuts to the bolts.
- The lower engine mount rubbers are assembled in the same way, except the male engine mount rubber is fitted to the engine mount pins first. Refer to Figure 42 below.
- Tighten nuts until firm. (Engine mount washer will touch the engine mount pin as the rubbers compress)
- Connect the fuel line to fuel pump (Refer to Figure 41). Ensure the fireproof sleeve is in place.
- Ensure the fuel line from fuel pump to the carburettor is connected & protected by fireproof sleeve.
- Ensure that the fuel overflow line is in place, and secured to vent overboard. This is the small, clear hose shown leading from the fuel pump in Figure 41.
- Fit the oil over flow bottle to the firewall by drilling and Riveting oil bottle holder in place using 73AS 6-6 rivets. Refer to Figure 9.
- Connect the oil breather line from the engine breather.
- Ensure that the oil overflow line is in place and vents overboard.
- Fit Scat hoses from NACA duct to Air Inlet Housing Assembly, from hot air muff to carburettor heat inlet on the hot air mixer box and from the hot air mixer box to carburettor – shown in Figure 44.
- Fit throttle cable to carburettor. Note that Jabiru Aircraft kits come with a throttle cable cut to length and with the correct end fitting attached. Engines used in firewall-forward kits will be supplied with a length of throttle cable with no end – the builder must cut the cable to length and fit the carburettor end fitting. 5/16" washers are used on the cable end fitting (one washer either side of cable end fitting) to align cable. Use R-clip to assemble. Figure 46 refers.
- Fit choke cable to carburettor. Use an R-clip to assemble. Note that the fuel line from the fuel pump to the carburettor passes between the choke and throttle cables. The choke is shown in Figure 8.
- Connect the fuel balance tube from the nipple on the carburettor to a fitting on the filtered air side of the air mixer box.
- Fit cylinder head temperature (CHT) sensor. The CHT sensor used in Jabiru aircraft is a J-type thermocouple. The VDO 310 980 Cylinder Head Temperature Gauge Kit is compatible with this sensor and is installed as standard equipment in Jabiru Aircraft. Note that to ensure an accurate temperature reading it is important to have the cold junction for the CHT (the plug between the stiff thermocouple wires and the normal, plastic-insulated gauge wires) located away from the heat of the engine. Refer to Figure 22.
- The Oil Temperature Sensor used is a VDO 320 028 which is located in the bottom of the sump as shown in Figure 17.
- The oil pressure sensor is located at the base of the oil filter and this can be seen in Figure 19. The sensor used is VDO 360 001.
- The exhaust gas probe used on Jabiru engines is a VDO 310 306 Pyrometer which is supplied as a complete kit. The probe is mounted in a fitting which is welded to an exhaust pipe. **Note that this fitting is not standard.** The installation of the fitting is best done at the time of order, though if required the exhaust pipe may be returned to Jabiru and the fitting added. Note that in this case it will normally take around 2 weeks before the pipe is returned to you. The fitting is welded to the pipe 100mm down from the exhaust manifold mounting plate.

- The Tachometer sensor used is a 6.35 x 22 mm analogue magnetic pick-up and is fitted to a bracket on the alternator housing. Refer to Figure 15. The sensor picks up on 2 tags fitted behind the flywheel.

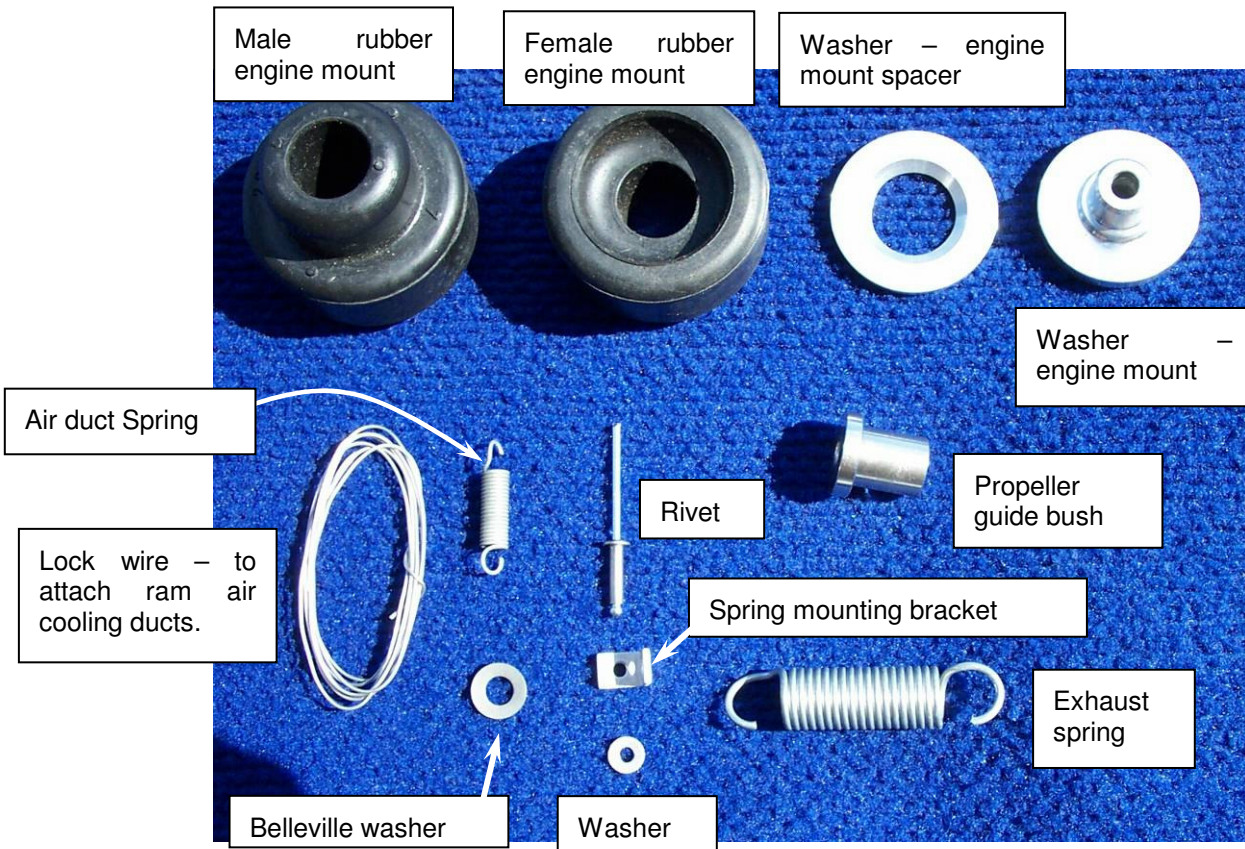

Figure 40. Engine Accessory Pack Contents

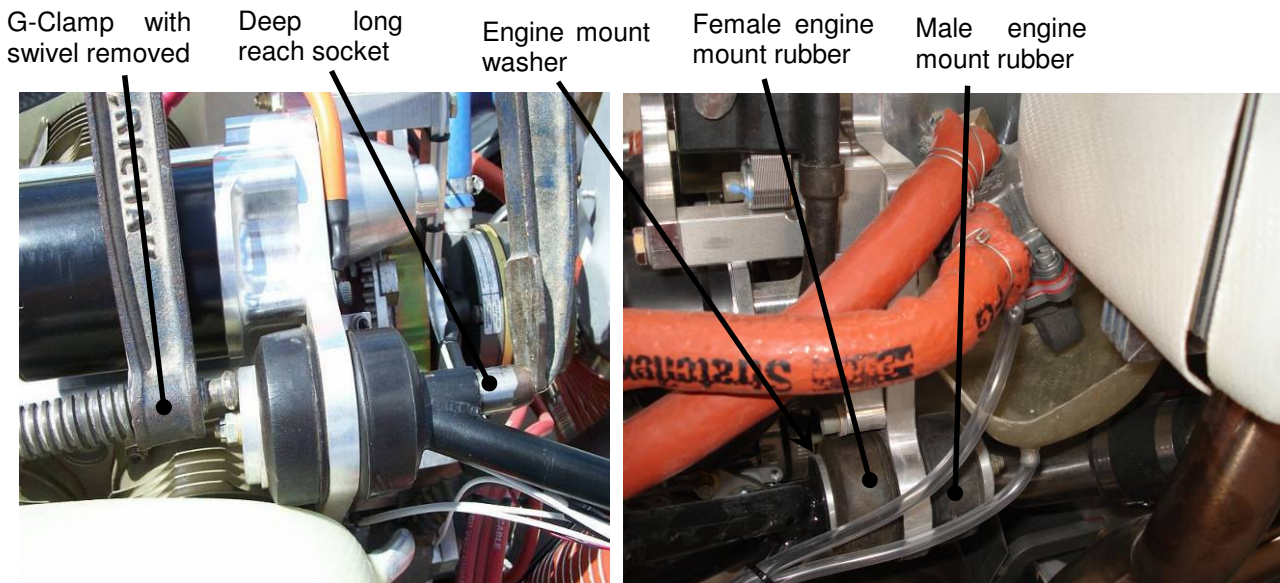

Figure 41 Upper & Lower Engine Mount Detail

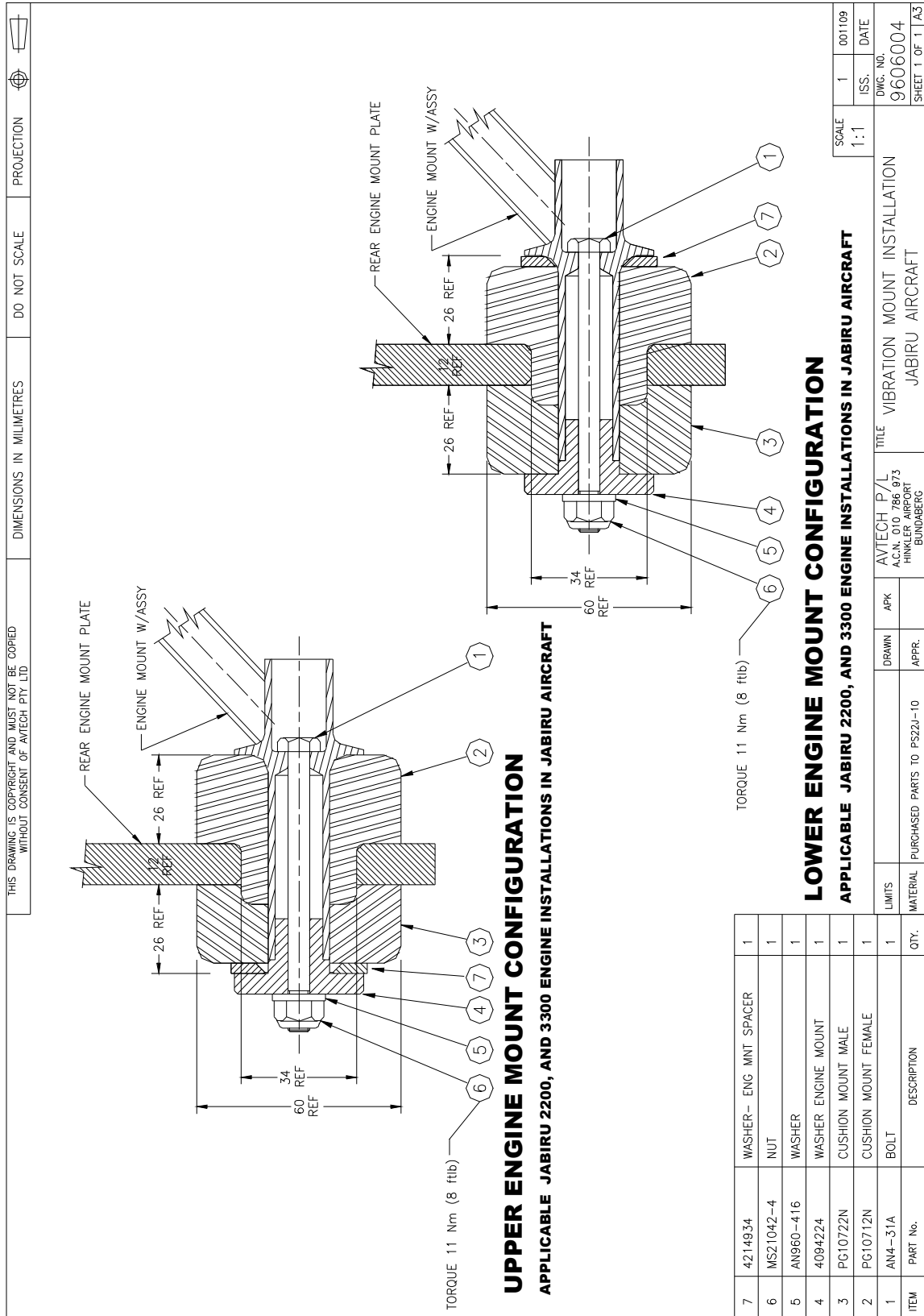

Figure 42. Engine Mount Detail

Fuel line from firewall fitting to mechanical fuel pump

Fuel line from mechanical fuel pump to carburettor

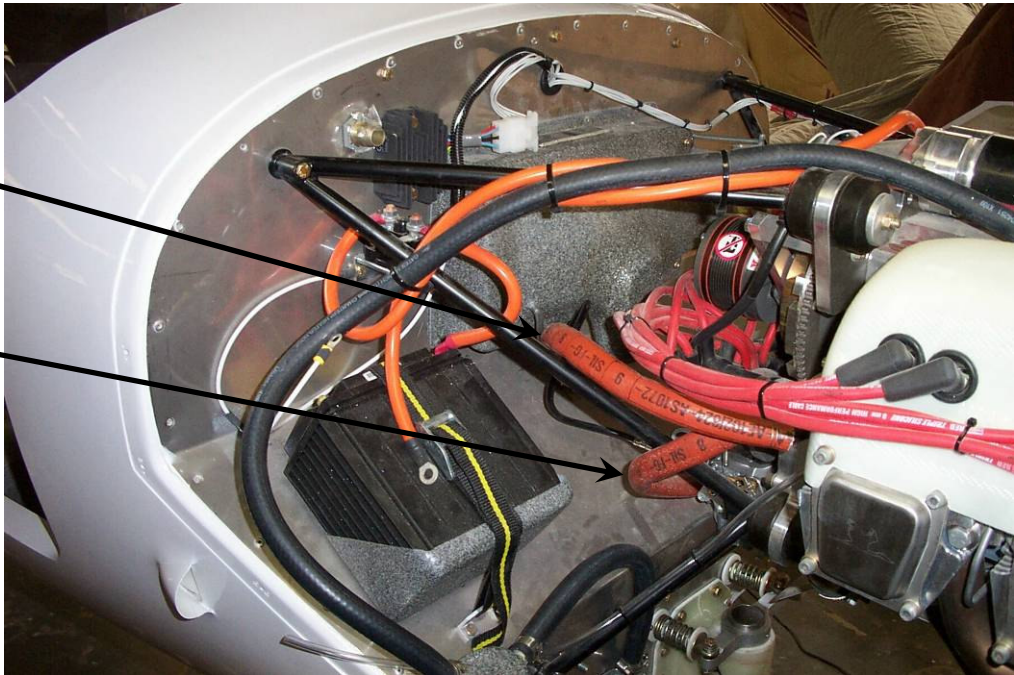

Figure 43. Fuel Connections General

SCAT hose from NACA inlet to air box

SCAT hose from hot air muff on exhaust to air box



Figure 44. SCAT Hose Detail



Balance tube connecting filtered side of air mixer box to nipple on carburettor.



Figure 45. Balance Tube Detail

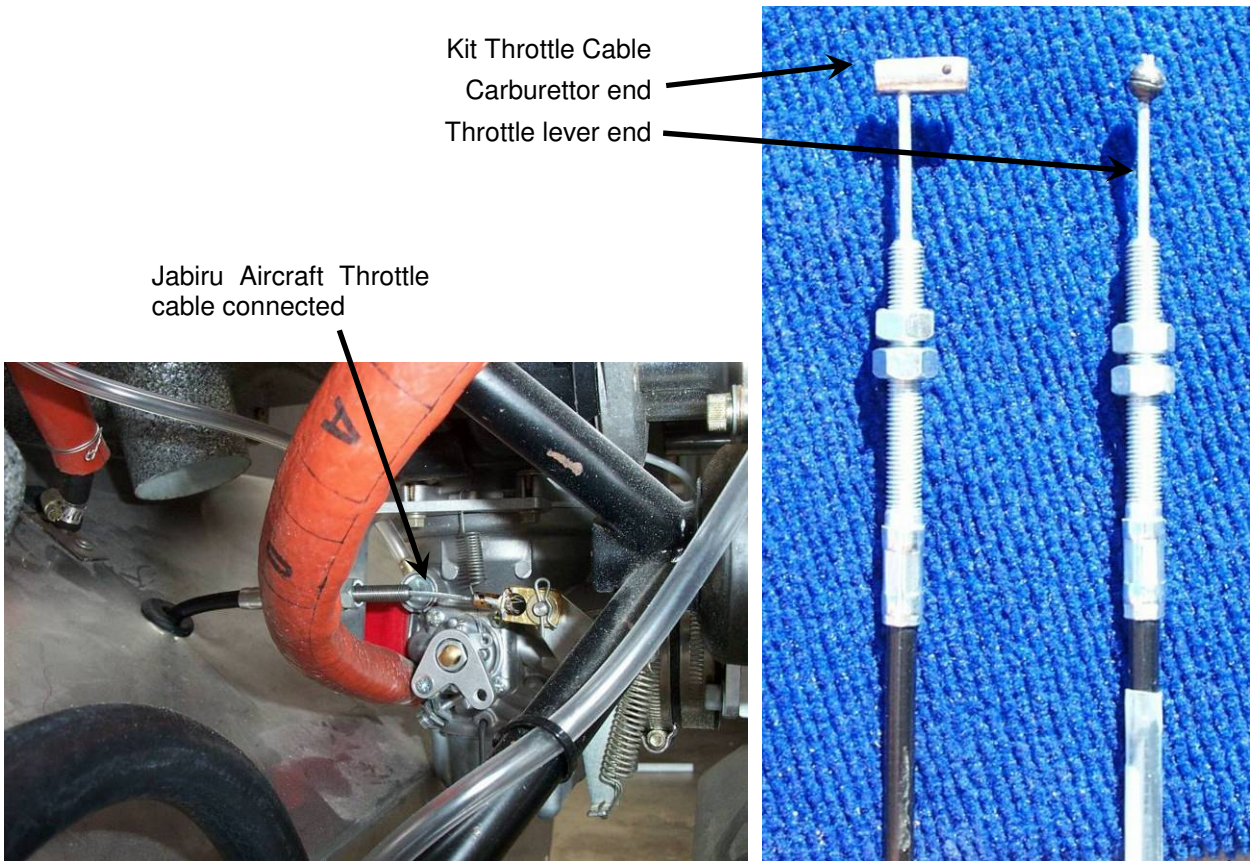

Figure 46. Control Connections to Carburettor



11 Before First Start

- Expel inhibiting oil from cylinders and pressure up (wind engine on starter until a the oil pressure gauge shows a reading) before first start.
- Ensure correct run-in type oil is used for the first 25 – 30 hours to ensure proper ring bedding-in.
- Once past the initial 25-30 hours, ensure the oil used meets the specifications given above.
- Oil coolers are mandatory unless operating in very cold ambient temperatures. Refer to Oil Cooling section above for allowable oil operating temperature ranges.
- Do not overfill the engine – this may result in high oil temperatures.
- Check for contact of engine, cooler or ducts on cowl. Any contact will cause excessive vibration & if the oil cooler is rubbing it will eventually fail & leak.



12 Auxiliary Units

12.1 Vacuum Pump

- For the installation of an artificial horizon and/or a direction gyro a vacuum pump is necessary. A Tempest 212CW (or equivalent) vacuum pump can be fitted to the alternator mounting plate and directly coupled to the crankshaft. The drive pad is dry.
- The pad and spline are SAE Standard.
- For later engines (S/No. 1522 and onwards) the vacuum pump drive spline is an option extra not included with the standard engine – it must be ordered separately.



13 Cooling Systems

13.1 General Principles

- An ideal cooling system:
 - i. Controls engine temperatures through speeds ranging from taxiing on the ground through to V_{NE} .
 - ii. Controls the engine temperatures through a wide range of angles of attack.
 - iii. Is simple to build, install and maintain
 - iv. Produces minimum drag
 - v. Requires no pilot attention
 - vi. Is not affected by rain, dirt or insects sticking to it.
 - vii. And weighs next to nothing
- For the sake of the following discussion, a “gap” is considered an opening roughly large enough to slide two fingers into – around 13mm by 32mm (0.5” by 1 ¼”).
- The total area of the air intakes (combined cylinder head and oil cooling openings) should generally be no more than one third the total area of the cowl outlet (the outlet area must be a minimum of about 3 times as large as the total area of the inlets). This assumes that the outlet area is oriented effectively (see Figure 58).
- Each cowl cylinder head Inlet of a Jabiru Aircraft has an area of approximately 10,500mm² (16.25 in²). Oil cooler inlets have an area of approximately 12,500mm² (19.4 in²). This gives a required total outlet area of approximately 100,500mm² (155 in²). These sizes are based on a Jabiru Aircraft. Inlet and outlet sizes required will vary depending on the aircraft’s speed, drag and the positions of the inlets and outlets – the areas given should be used as a guide and starting point only.
- A generalised picture of the airflow and air temperature is shown in Figure 47.
- Most of the time, air leaking through gaps instead of flowing through a cylinder head, oil cooler or similar is waste air – it does not transfer heat and does not cool the engine. Sometimes air leaking through controlled gaps – such as the holes in the front of the ram air ducts (Figure 50) or the gaps between cylinders – can have beneficial effects. However, it is recommended that gaps around the engine and oil cooler be closed as a starting point.
- The propeller & rush of air from the aircraft’s speed make it easier to get air into the cowl than to get it out.
- Too much air flowing through the oil cooler can restrict airflow through the cylinder heads, & vice versa.
- The pressure difference between the low pressure outlet area of the cowls and the high pressure inlet areas controls the amount of air flowing through the engine. The pressure differential testing described in Section 13.5 gives target pressures.
- During developmental work it is strongly recommended that each cylinder head has it’s own temperature sensor. Modifications to cowls etc can have unpredictable effects and normally a change will affect each cylinder head differently – i.e. head #4 may cool down while head #3 heats up.
- Testing of an installation in a Jabiru Aircraft showed that the heat radiating from the engine exhaust system normally has a minimal effect. Wrapping the exhaust in insulation etc does not produce a measurable temperature reduction during taxi or in the air.

WARNING

The limits in the Specification Sheet, contained in Appendix B, must be strictly adhered to. Warranty will not be paid on engine damage attributed to overheating of cylinders or oil.

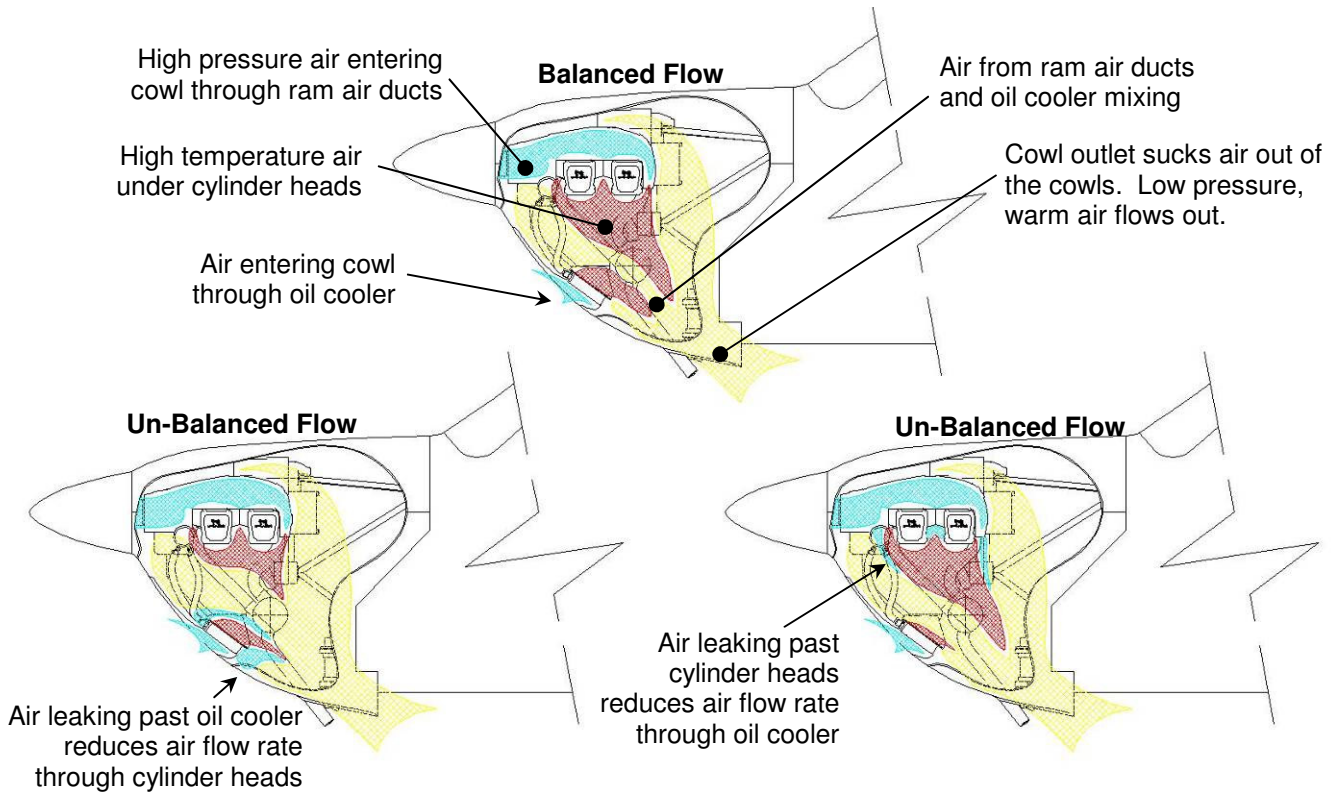

Figure 47. Cowl Airflow (Best Viewed in Colour)

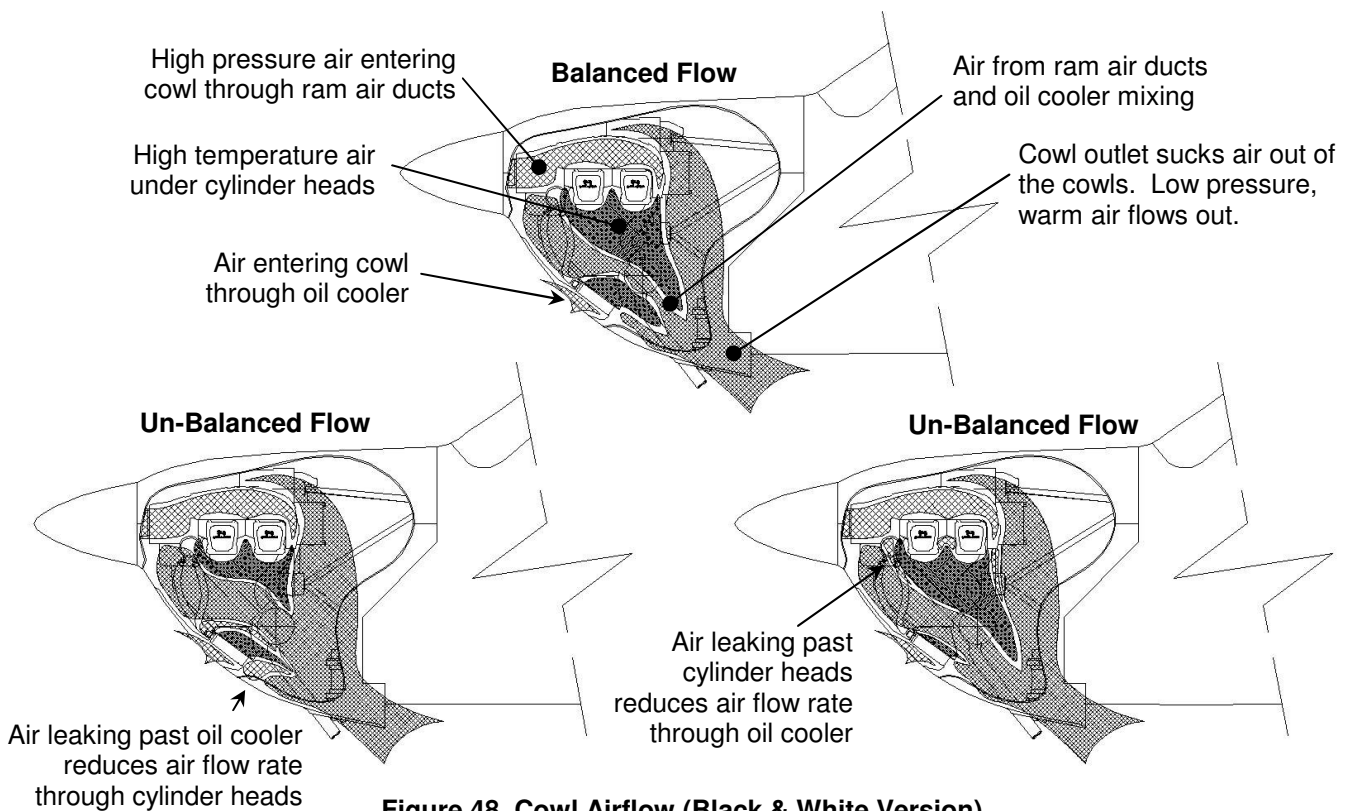
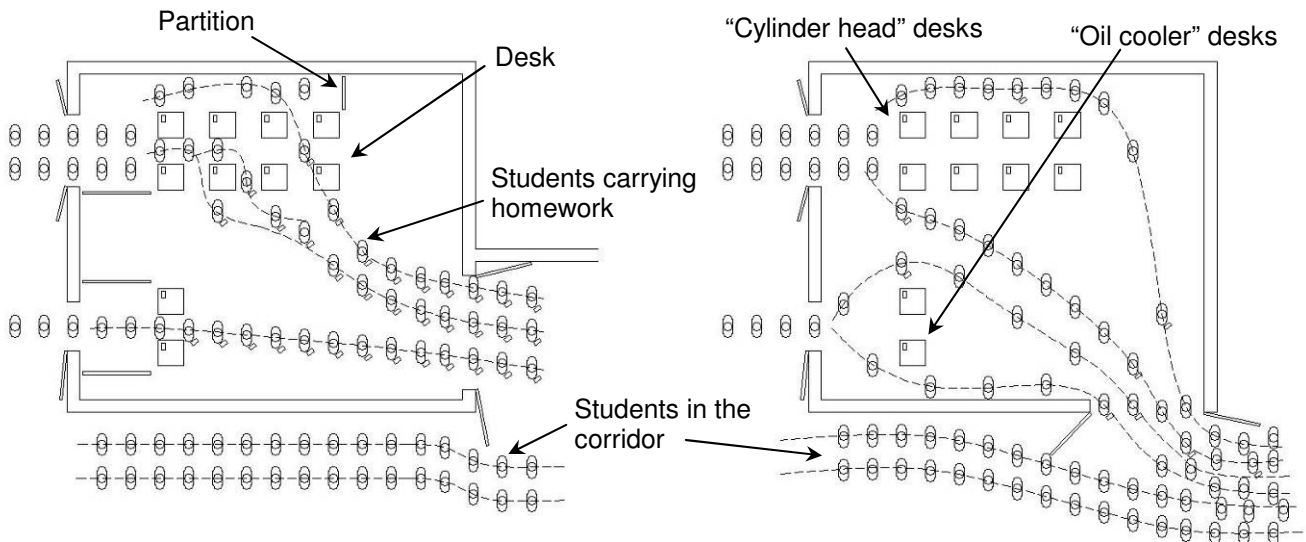

Figure 48. Cowl Airflow (Black & White Version)

13.2 Flow Visualisation

- In designing the cooling system the designer must have a basic understanding of how air flows and behaves inside the cowl. The pictures below are intended to explain it in simple terms.
- Figure 49 shows two schoolrooms, drawn as if seen from above. Each room represents an engine and oil cooler inside a cowling.
 - There are two doors in the inlet side of the room and one on the outlet side.
 - Several desks are placed in the room, representing the engine cylinders and the oil cooler.
 - Students walk through from left to right, representing the air flow through the cowls.
 - On each desk is a pile of homework papers, representing heat generated by the engine.
- Air always takes the path of least resistance. It tries to escape quickly to the playground without taking the homework.
- The desks and doorways form restrictions. If the desks are too close, not enough students can pass through. If the desks are too far apart some students will not pick up their homework. If the inlet doorways are too large then there will be a traffic jam trying to get out of the outlet door.
- Gaps can leave room for students to pass without picking up homework.
- Given a group of desks as shown, students can follow many paths through them – from front to rear, from top to bottom or any combination.
- Slowing down the students as they pass through the desks means they will pick up their homework, but if they are slowed down anywhere else it only reduces the amount of students that can get through the room.
- If the exit becomes jammed with people, installing bigger inlet doors will not increase the number of students passing through the room. Exits should be as clear and free of obstructions as possible to let people out.
- Students will often have a preferred desk to take their homework from, meaning that some cylinder heads will have more heat removed than others – temperatures will vary between different heads.



- Partitions are used to force the students to walk through the desks.
- Each student picks up the homework.
- Outlet door is 90° to the flow of students in the corridor; there is no restriction & jostling at the exit
- No partitions are used, so students walk around the desks instead of through them.
- Most students don't come close enough to a desk to pick up the homework
- Outlet door is parallel to the flow of students in the corridor, causing restriction & jostling at the exit

Figure 49. Flow Visualisation

13.3 Air Inlet & Ram Air Ducts

- The engine should be installed using RAM AIR ducts provided with the engine. The ducts themselves are to be assembled as detailed in Section 13.3.1.
- The ram air ducts are screwed to the engine using the normal rocker cover screws. Note that if the duct is not fastened to the engine then air pressure at high speed can lift the ducts off the engine. This will upset the pressure balance inside the cowl and impede cooling. More importantly, with some types of ducts, the duct lifting will dislodge the spark plug high tension leads, causing the engine to run roughly or stop.
- For best cooling on the ground, during climb and low speed flight the propeller used must have significant pitch and blade area on the section immediately in front of the air inlets. At low speeds the airflow does not have much energy, and the acceleration and pressure provided by the propeller greatly assists in getting air into the ram air ducts.
- Each duct must have a 25mm hole at the inside top front to bleed air over the crankcase.
- The pressure differential between the inside the cooling ducts and the cowl outlet must not be lower than 60mm (2.4") water gauge at when the aircraft's speed is 1.3 times the stall speed ($1.3 \times V_S$).
- The cooling ducts provided are a starting point in establishing effective engine cooling. The ducts may require to be increased in size and additional baffles provided for best cooling.
- Tubes of approximately 12mm diameter are required to provide cooling air to the ignition coils - Figure 51.
- For an air cooled engine it is entirely normal for there to be significant differences in the temperature of each cylinder head. Often the head which is hottest in the climb will not be the hottest during cruise & descent. This is only a problem if the hotter heads exceed the engine's set limits.
- "Gull Wing" baffles can be used to fine-tune the restriction to airflow caused by the engine, and this in turn affects the volume of air flowing through the engine and into the cowls. Fitting the baffles will give a higher restriction as it forces air to flow through the small gaps between fins. Leaving the baffles out provides larger gaps – and a higher volume of relatively cool air blows through these gaps into the "Hot" zone immediately under the cylinder heads. Wherever possible it is recommended to leave the baffles out. However, compared to an installation with the Gull Wings fitted, a significantly larger volume of air must be sucked out of the cowl outlet. This often requires a larger cowl outlet or a larger lip on the existing outlet. Pressure differentials must be maintained.
- Check for contact of engine, cooler or ducts on cowl. Any contact will cause excessive vibration & if the oil cooler is rubbing it will eventually fail & leak.

Front baffle in duct to prevent air slipping under cylinder & head

Rear baffle to direct air into rear cylinder head

Hole in ram air duct to blow cool air over the crankcase

"Gull Wing" baffles fitted between cylinders

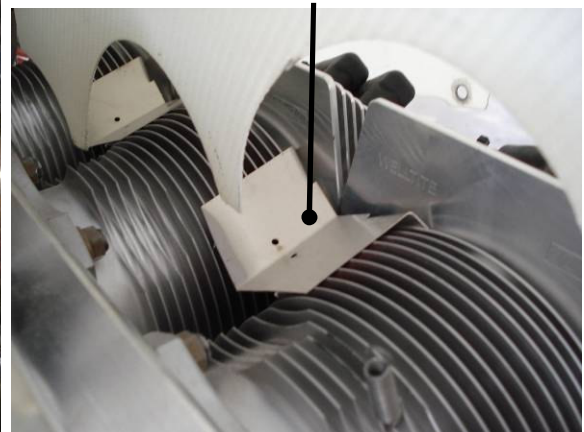
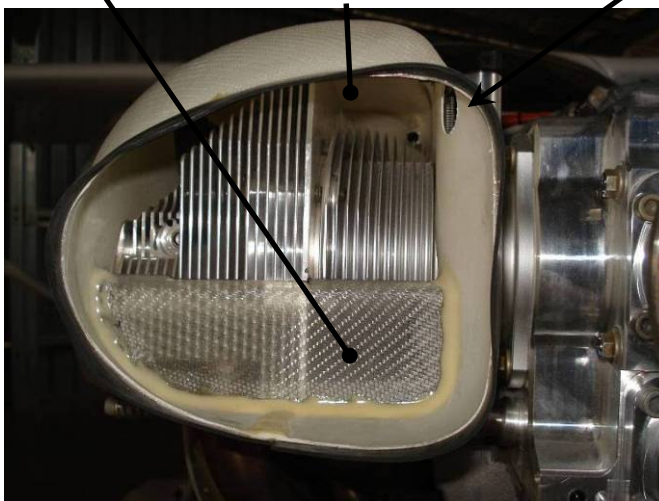

Figure 50. Front-On View Into Ram Air Duct

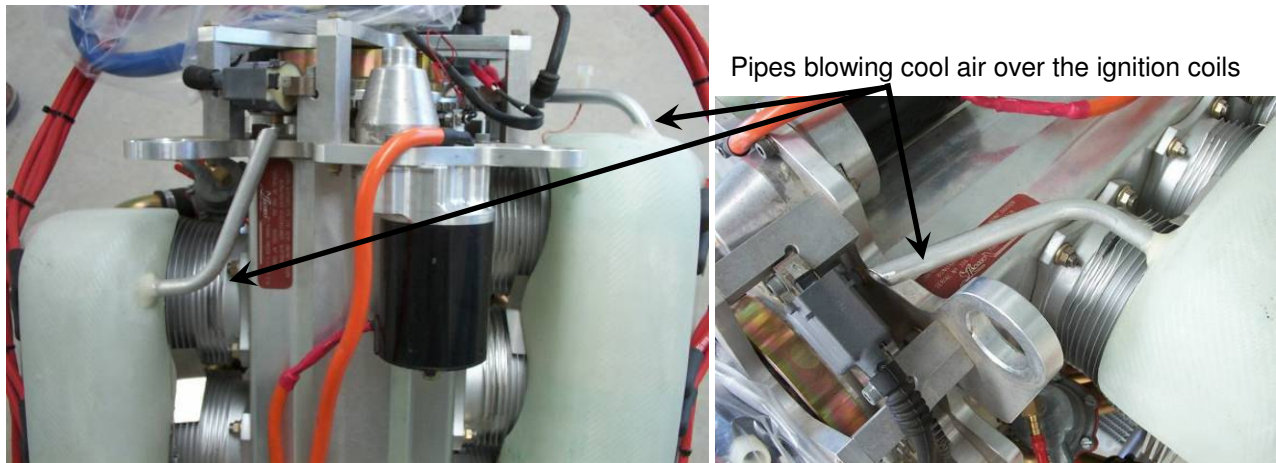

Figure 51. Coil Cooling Detail

13.3.1 Ram Air Duct Assembly & Installation

- As supplied, the seam at the front of the ram air duct is not joined. This joint must be bonded using 5-minute epoxy & flock. Use a length of masking tape on the join line at the bottom of each duct inlet to hold the join firm and prevent Epoxy/flock from leaking through.

Seam bonded with 5-minute epoxy.

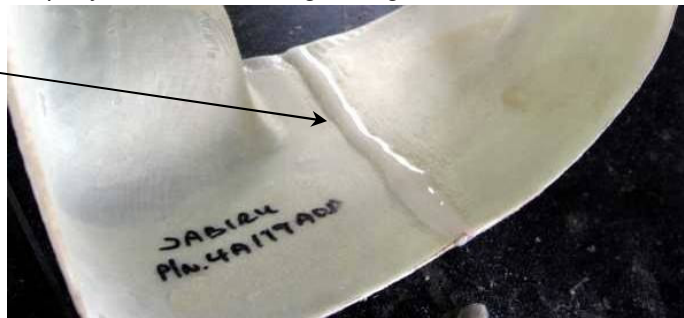

Figure 52. Ram Air Duct Front Seam

- Before installation the front air dams need to be cut to size. Take the length of glass fibre sheet with the curved edge, hold it against the rear of the duct inlet with the curve towards the top rear of the duct and mark around the bottom of the duct then cut to shape. Figure 53 refers.
- Tape the air dam into place. Mix a small batch of 5-minute Epoxy and flock and use it to fix the air dam into place. Leave to cure, then sand away any rough edges.
- Remove the masking tape and roughen the underside of the duct and the back of the air dam.
- Mix a small batch of epoxy resin (structural resin – not 5-minute epoxy) and brush 2 layers of AF303 glass fibre cloth to the underside of each duct, covering the join line and wrapping up around the back edge of the air dam. Leave overnight to cure.
- The completed baffle is shown in Figure 50.



Figure 53. Air Dam Installation

13.4 Oil Cooling

- The dipstick cap must be screwed fully in before removal for reading oil level.
- An oil cooler adapter is supplied with the engine & fits under the oil filter. The cooler can be plumbed either way to the adaptor – flow direction is not important. Oil coolers are available from Jabiru Aircraft.
- Unless consistently operating in low temperatures, oil coolers are mandatory. Note: if you fly in cold weather and don't have an oil cooler you can't fly if it warms up. You can always block the oil air off in cold conditions.
- In continuous operation oil temperatures between 80°C and 90°C (176°F – 194°F) are desirable. 70°C (158°F) is the minimum allowable temperature for continuous running and 100°C (212°F) is the maximum allowable temperature for continuous running.
- Over filling with oil is not desirable. It can cause elevated temperatures & excessive oil use & loss.
- Hoses should be nominally 10mm (3/8") bore.
- Hoses must be changed every 2 years or if visible degradation (cracking, hardening) is visible at inspection.
- A pressure drop of at least 60mm (2.4") water pressure between the air flowing into the cooler and the air flowing out of the cowls should provide sufficient oil cooling if using a standard Jabiru oil cooler.
- Section 13.1 noted that air leaking through gaps in the cooling system ducts is generally waste air, not contributing to cooling – though it noted that there were exceptions to this rule. Oil cooling is the feature of engine installations that is most often improved by "leaks" like this. A controlled amount of free air blowing over the sump, crankcase and underside of the engine can significantly improve oil temperatures (Figure 54 shows a duct of this type fitted to a Jabiru 6-cylinder engine). However, for this to work the cowl installation must be able to cope with the extra volume of air flowing into the cowl space – the outlet area or outlet lip size may need to be increased to suck out the extra volume.
- Figure 55 shows an oil cooler installation of a Jabiru 3300. Note Detail C in the lower corner of the drawing, which shows the cooler being fitted using rubber mounts. This is very important as it insulates the cooler from engine vibrations – coolers installed with a soft mount like this are much less likely to fail in service.

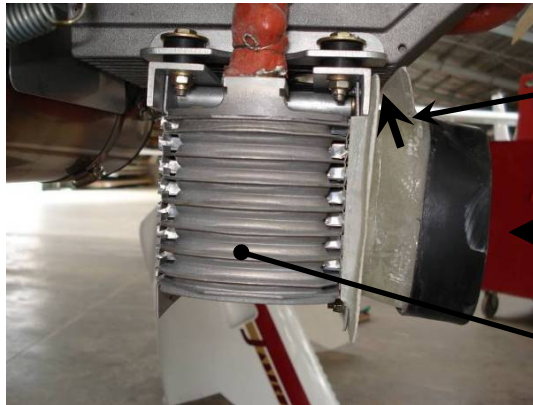

Controlled gap "leaking" air over the sump and lower parts of the engine.

Airflow in

Oil Cooler

Figure 54. Oil Cooler Duct Design

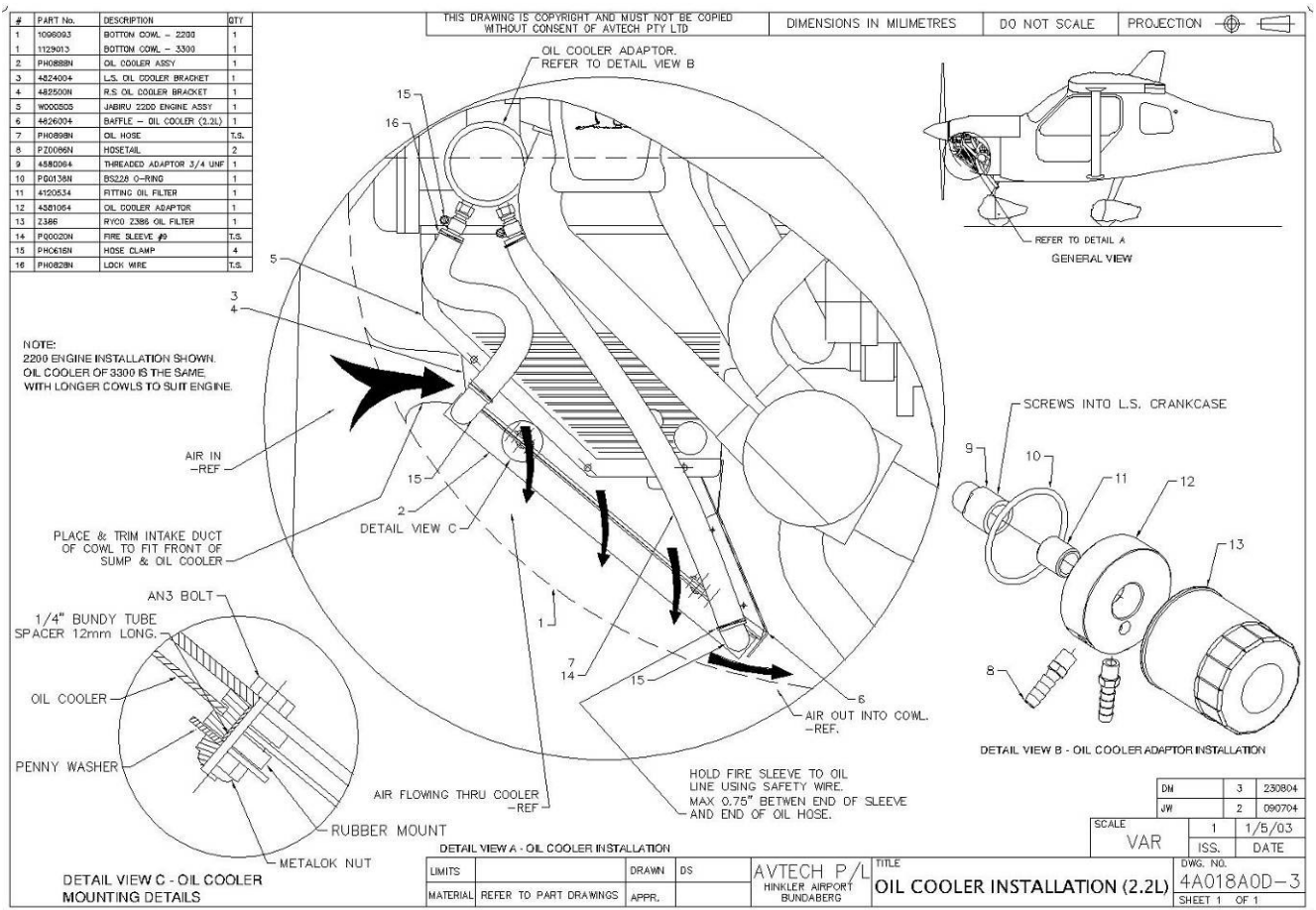

Figure 55. Oil Cooler Installation

13.5 Air Outlet

- As the sections above describe, getting air out of the cowling is often the factor limiting how much air can be pushed through the engine and how well it is cooled.
- The shape of the outlet of the cowls controls how effectively air is sucked out of the cowling and is arguably the single most important aspect of cowling design.
- As noted above, as a rule of thumb the cowl outlet area should be at least 3 times the combined area of all the cowl inlets.
- Figure 56 shows a small lip added to the rear of the cowls of a Jabiru Aircraft. This lip gives a large improvement to pressure differentials and engine cooling.

- Figure 57 shows an aircraft at varied angles of attack to the surrounding air. The cowl inlets and outlets must both be designed to work effectively at all angles which the aircraft will normally experience.
- Figure 58 shows two different cowl outlets – one is basically an opening in the flat bottom of the cowl, while for the other the opening is oriented at 90° to the airflow direction. Vertical orientations (Deep Outlet) give better pressure differentials and are less affected by aircraft angle of attack than horizontal (Long Outlet).
- Figure 58 also shows the lower firewall section of a Jabiru Aircraft. The lower part of the fuselage has two large ramps moulded in which increase the depth and area of the cowl outlet (and also provides mounting points for the rudder pedals). This type of feature is not mandatory for good engine cooling but it does help. An alternative is to make the bottom corner of the firewall as smooth and rounded as possible to help airflow and minimise the outlet restriction.
- Some aircraft types have a flange running around the firewall. Particularly on metal types, this flange is a useful way of mounting the cowls. However, if the flange runs across the edge of the firewall where the cowl outlet is located then it causes a significant flow restriction. Figure 59 shows a drawing of the lower section of a firewall with a flange of this type. Wherever possible flanges across the cowl outlet should be avoided. Alternatively a fairing can be built inside the cowl to smooth airflow over the lip & reduce flow restriction.



Figure 56: Lip to aid cooling as installed on a Jabiru.

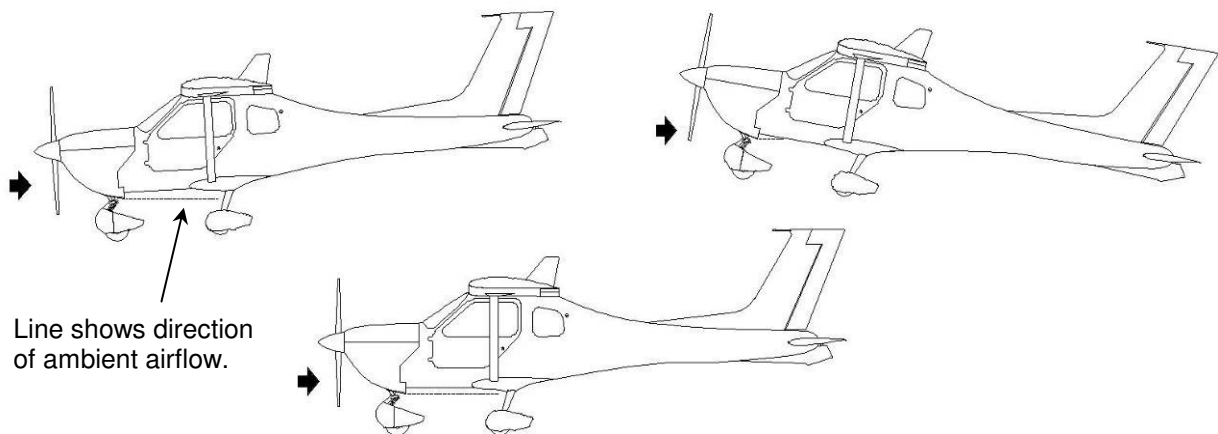

Figure 57. Affect of Angle of Attack on Cowl Outlets

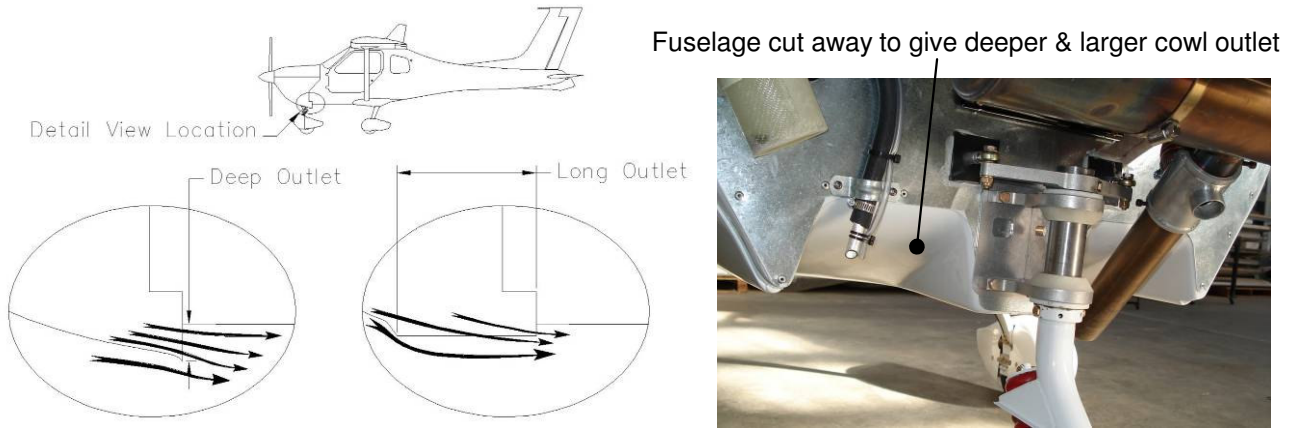

Figure 58. Cowl Outlet Geometry

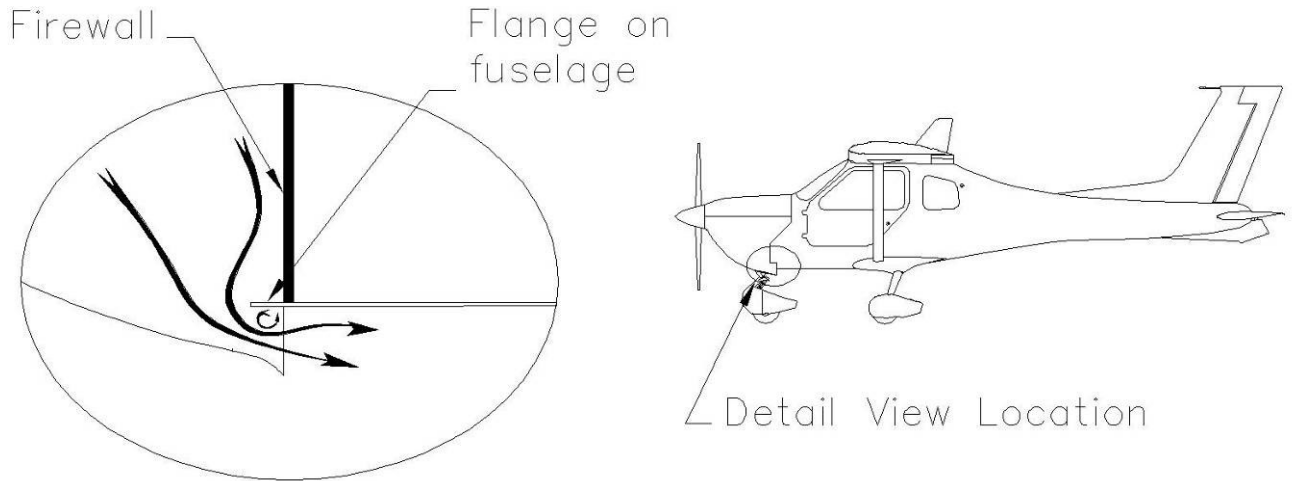

Figure 59. Outlet Restriction Caused By Flange On Lower Firewall

13.6 Cooling System Testing & Evaluation

- For new installations (new designs rather than new aircraft of a known type) the pressure drop across both Ram air ducts must be checked.
- The following is a guide to evaluating an engine installation to see if it meets minimum cooling requirements.
- The easiest way to measure the air pressure drop across the engine and oil cooler is using a U tube manometer using water. It is basically a piece of clear tube bent into a "U" and half filled with water (if the water is hard to see add a bit of food colouring).
- For ram-air duct pressure, connect one side of U to a static port inside the ram air duct and the other to a static probe inside the cowl near the outlet. For the pressure drop across the oil cooler plumb a static probe against the front of the cooler and a static probe inside the cowl near the outlet. The further the probe is in front of the cooler the less the static pressure that will be measured, so place the probe no more than 5mm in front of the cooler and parallel to it.
- Using multiple U-tubes several measurements can be taken in one flight.
- Details of a typical static probe are shown in Figure 60.
- Note that probes must be fitted in the same place each time to ensure you get consistent measurements.

Some hints.

- Usually the most critical situation for cooling is climb however this is not always true, so check all situations.
- The change in air temperature is approximately the same as the change in engine temp. For example if you did all your testing in 15°C and you want to flying in up to 35°C weather, in 35°C all your engine temps will be approximately 20°C higher. Check you have sufficient margin for all conditions you plan to fly in.
- If the engine gets too hot during testing don't push it. Something needs to be changed.
- For low speed cooling a lip on the front edge cowl outlet can add up to 20mm of pressure drop at 65kts (a lip 25mm deep at 60° to the airflow – shown in Figure 56).
- Refer to Figure 22. CHT terminals must be placed correctly or inaccurate (too high) readings can result.

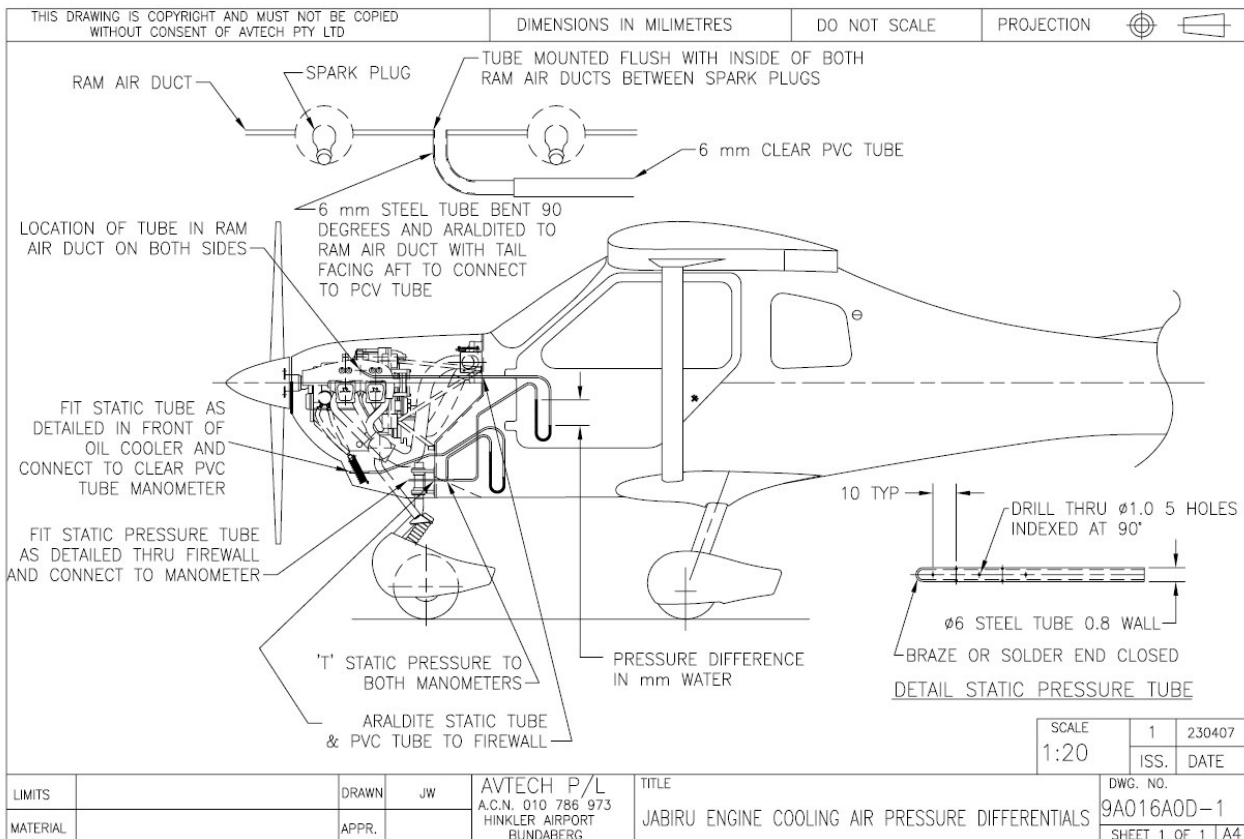

Figure 60: Cooling pressure measurement.



Figure 61: Ram Air duct pressure tapping.

13.7 Pusher Installations

- For pusher installations the details given above hold, though some changes are necessary for the different configuration.
- Versions of Jabiru ram air ducts are available for high speed and low speed pusher installations.
- The propeller can be used to suck air out of the cowls, using the following as a guide:
 - i. Wherever possible the cowl outlets should be vertical openings with lips that come close to the propeller – as close a possible without the blades hitting the cowls.
 - ii. The propeller blade must have significant pitch and chord in the section which passes over the outlets.
 - iii. The cowl openings should each be reasonably small. As each blade passes the opening it will create a suction in the cowl behind it, but if the cowl opening is large this effect will be dissipated. Alternatively, larger openings can be divided up by fitting louvers or vanes.
- Augmentor type exhausts (Figure 62) can also be used to suck air out of the cowlings.
- In pusher installations the inlets into the cowl are harder to get right than in a tractor installation. Intake ducts should be as straight as possible with no sharp corners or other restrictions to the flow.
- The position of the cowl air inlets is critical – inlets on the upper surface of the aircraft are generally in low pressure zones while those on the underside are normally in high pressure zones. Depending where the inlet is located, the area ratio between inlet and outlets may need to be modified.

13.8 Amphibian or Seaplane Installations

- Water taxiing requires relatively high power settings for long periods and this is often the most critical condition for cooling systems in these aircraft.
- Increased duct size (scooping more air through the engine) may be necessary.
- For amphibian or seaplane aircraft using a pusher engine installation the methods outlined above can use the propeller to suck air out of the cowls, but ultimately the effect is limited and can conflict with cooling requirements in other modes of flight. For these installations some form of active venting for the cowls – such as flaps, fans or an augmentor-type exhaust system (See Figure 62) may be required.

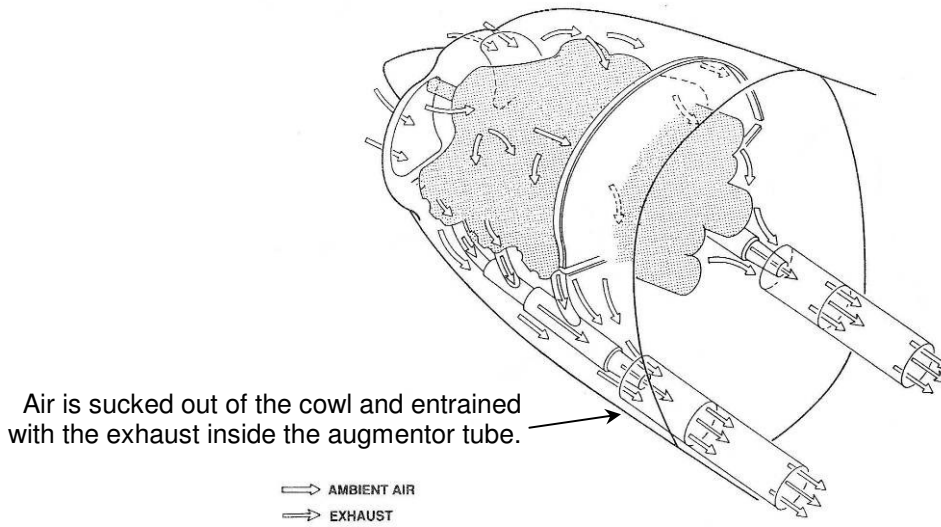

Figure 62. Augmentor Exhaust System

13.9 Slow Speed Installations

- Installations where the cruise speed is below around 70 – 80 knots are considered slow speed installations.
- Jabiru ram air ducts are available for slow speed installations. These are larger than the ducts used for faster aircraft.
- Increased duct size (scooping more air through the engine) may be necessary for slow speed installations.
- Increased outlet size and more aggressive outlet lips may be required.
- In some of these installations where the airframe has a lot of drag it is preferable to do away with cowls altogether and run an open installation. Aircraft such as the Thruster (Vision), Drifter, X-Air and some RANS models are examples of this. In these cases large ram air ducts are used, and the rest of the engine is exposed to the propeller wash for cooling.

14 Appendix A – Wiring Diagrams

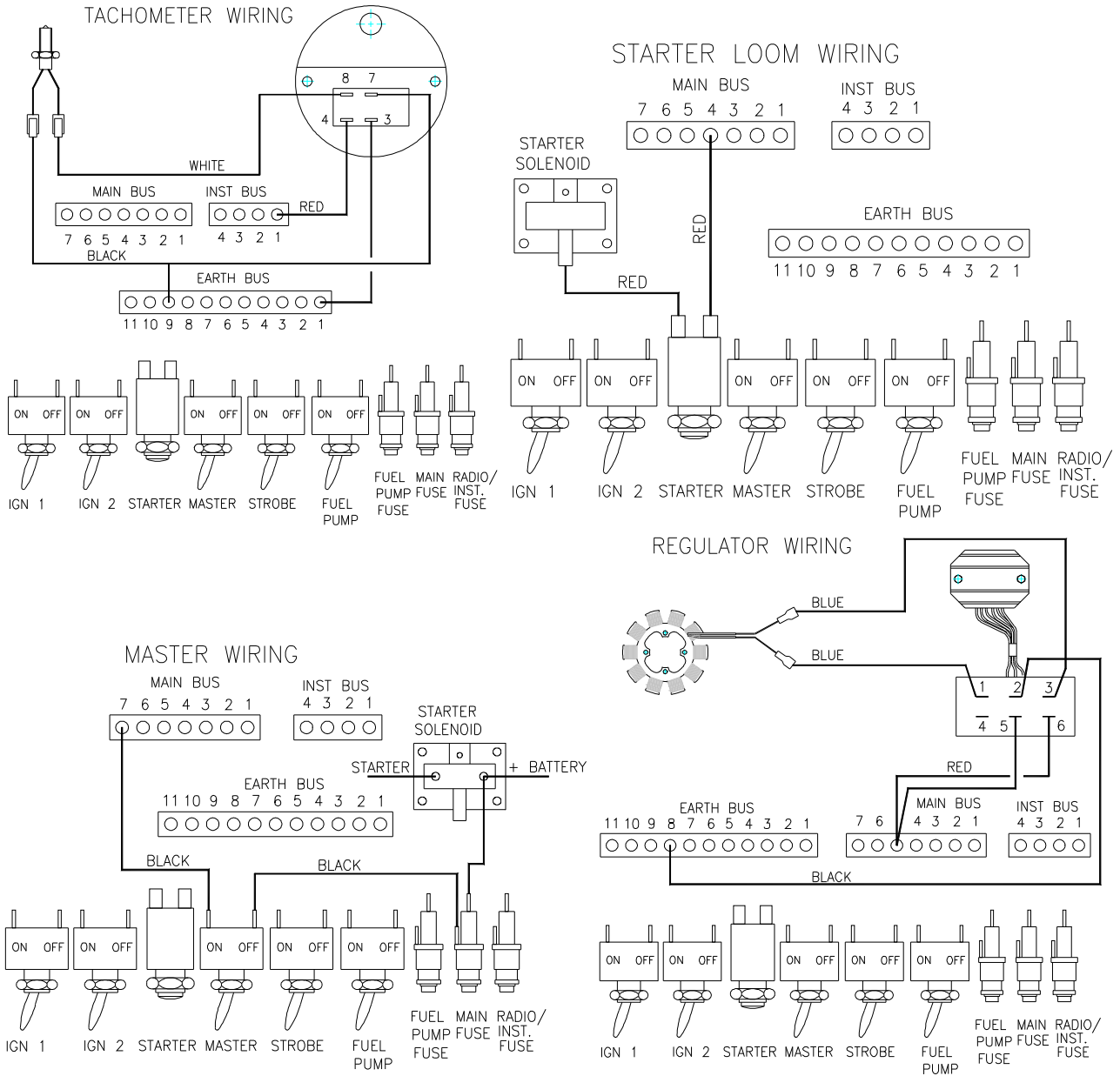

Figure 63. Wiring Details



15 Appendix B – Jabiru Aircraft Installation

- The following information describes the installation and performance of a Jabiru SP Aircraft fitted with the 3300 engine.
- The information given can be used to estimate the performance of different designs, though obviously there will be differences depending on how similar the aircraft is to the Jabiru described below.
- Poor installations will result in poor performance, so installations must be designed referencing the information given in the main body of this manual.

15.1 Known Airframe / Engine Details

- Jabiru SP (2 Seater)
- Propeller 60" x 53" (1525mm x 1346mm) or
- 60" x 48" (1525mm x 1219mm)

15.2 Normal Operation Data

- The following are typical values for the engine when installed in a Jabiru SP:

Idle Hot:.....	900 – 950 RPM
Take Off Power:.....	2800 RPM (60" x 53" Propeller)
.....	2900 RPM (60" x 48" Propeller)
Full Power S&L:	3200 RPM (60" x 53" Propeller)
.....	3300 RPM (60" x 48" Propeller)
Cruise At 75% Power:.....	2750 - 2850 RPM
Oil Pressure:	400 kPa (58 psi)
Oil Temperature Cruise:	80°C (175 °F)
Oil Temperature Climb:.....	95°C (203°F)
Cruise CHT:	121°C (250°F)
Climb CHT:	177°C (350°F)
Climb EGT:	650°C (1202°F)
Cruise EGT:	690°C (1274°F)
Mechanical Fuel Pump Pressure	3 lbs (20 kPa)



16 Engine Installation Checklist

ENGINE MOUNT

- Positions engine for correct aircraft CG
- Positions engine for correct thrust line
- Sufficient strength
- Sufficient stiffness
- Provides access for maintenance
- Provides clearance – the engine and mount are not rubbing on other parts of the aircraft.

ENGINE CONTROLS

- Control cables bend radii sufficient
- Control cables not rubbing on other parts.
- Control cables set up to work in the correct direction

ELECTRICAL SYSTEMS

- Correct sized circuit breakers used
- Connections for power & earth correct size
- Correct type of sender units used for instruments (i.e. resistive or voltage type).
- Sender units used chosen to suit typical parameter ranges of a Jabiru Engine
- Aircraft grade wiring used.
- CHT cold junction positioned correctly.
- EGT probe located correctly.
- Starter solenoid earthed
- Regulator earthed
- Battery mounted close to the engine
- Anti RF noise measures taken

FUEL SUPPLY SYSTEM

- Electric backup pump installed
- Electric pump supply pressure within limits
- Fuel line bend radii sufficient
- All fittings fwd of firewall fireproof
- System designed to prevent vapour-lock

AIR INDUCTION SYSTEM

- “Cobra Head” fitted
- Duct to carburettor as direct as possible
- No sharp edges or sharp corners in system
- Carburettor heat system working correctly
- Backfire flap fitted to air box
- Drain holes drilled in air box
- Carburettor sense pipe connected correctly
- EGT’s evaluated

EXHAUST SYSTEM

- Sufficient clearance – no rubbing on aircraft.
- Heat muffs for carb and cabin heat included.
- Outlet positioned correctly
- Noise levels satisfactory

COOLING

- Cowl inlet / outlet ratio correct
- Cowl inlets located & shaped correctly
- Cowl outlets located & shaped correctly
- Cowl inlets “sealed”
- Crankcase and coil cooling correct
- Pressure differentials correct
- Engine temperatures correct