

PUMP SHIFT INTERLOCK PANEL 3050658-68



PUMP SHIFT INTERLOCK PANEL 3050658-68 (rear)



DT15-4P ROAD / PUMP Solenoids

DT15-12PA Vehicle Interface

Vehicle Interface



DT15-12PA Mating connector is DT06-12SA with W12S wedgelock

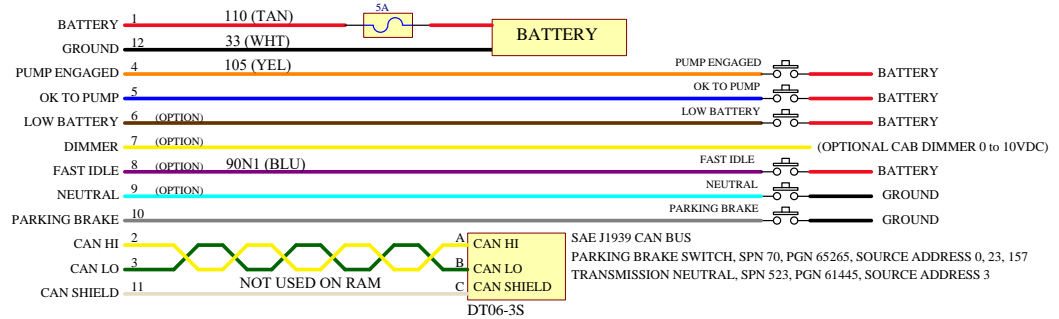

ROAD / PUMP Solenoids



DT15-4P Mating connector is DT06-4S with W4S wedgelock

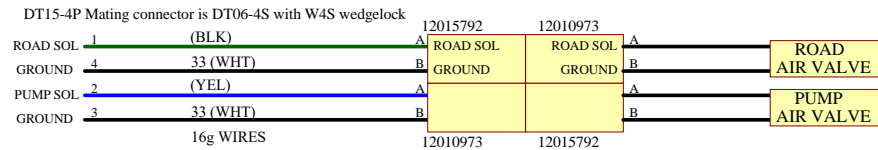

56581-16

PROPRIETARY AND CONFIDENTIAL
 INNOVATIVE CONTROLS INC. PROPRIETARY - THE INFORMATION CONTAINED IN THIS DRAWING IS THE SOLE PROPERTY OF INNOVATIVE CONTROLS INC. ANY REPRODUCTION IN PART OR AS A WHOLE WITHOUT THE WRITTEN PERMISSION OF INNOVATIVE CONTROLS INC. IS PROHIBITED.

Innovative Controls
 560 Braddock Ave.
 East Pittsburgh, PA 15112
 T: 412.824.2264
 F: 412.824.2339
 www.innovativecontrolsinc.com



Drawing Number:
 3050658-68
 Variant: HME Revision: 1.0 Drawn By: KW
 Project Title: Pump Interlock Panel Checked By: PS
 Description: Pump Interlock Panel Wiring
 Date: 7/31/2018 Time: 10:37:10 AM Sheet 1 of 1
 File: 3050658-68_PumpInterlockPanelWiring_Sheet1_Rev1-0.SchDoc