

BILL OF MATERIAL

ITEM	QTY PER	PART No.	CODE	DESCRIPTION	SUPPLIER PART No.
1	1	3009135	MFG	PANEL, HME, PUMP SHIFT, ROAD-TO-PUMP (TOP), PUMP-TO-ROAD (BOTTOM), W/STUDS	
2	1	3009136	MFG	SPACER, HME, PUMP SHIFT	
3	6	4050889	PUR	WASHER, FLAT, #4, SS, .031 THICK, FASTENAL	1171003
4	6	4050890	PUR	WASHER, LOCK, #4, SS, FASTENAL	1171053
5	6	4050907	PUR	NUT, HEX, #4-40, STAINLESS, FASTENAL	70704
6	1	4060064	MFG	SOFTWARE, HME PUMP SHIIFT INTERLOCK PANEL	
7	1	4090195X	MFG	PCB, HME PUMP SHIFT PANEL - SEE TABLE A FOR SPECIFIC PCB P/N.	

TABLE A - PRODUCT VARIANTS

CODE	PRODUCT DESCRIPTION	IC LABEL P/N	PCB	SOFTWARE
01	HME PUMP SHIFT, ROAD ON TOP, WITH INDICATORS.	3009134-01	4090195A	4060064
02	HME PUMP SHIFT, ROAD ON TOP, WITHOUT INDICATORS.	3009134-02	4090195B	4060064
03	HME PUMP SHIFT, FORD, ROAD ON TOP, WITHOUT INDICATORS.	3009134-03	4090195B	4060064
04	HME PUMP SHIFT, DODGE, ROAD ON TOP, WITHOUT INDICATORS.	3009134-04	4090195B	4060064
05	HME PUMP SHIFT (NO INTERLOCK), FORD, ROAD ON TOP, WITHOUT INDICATORS, 2-POS SWITCH	3009134-05	4090195C	4060104

SEE TABLE A FOR LABEL CODE
SEE IC DWG 3009134-XX FOR LABEL LAYOUTS
(3009134-01 SHOWN)

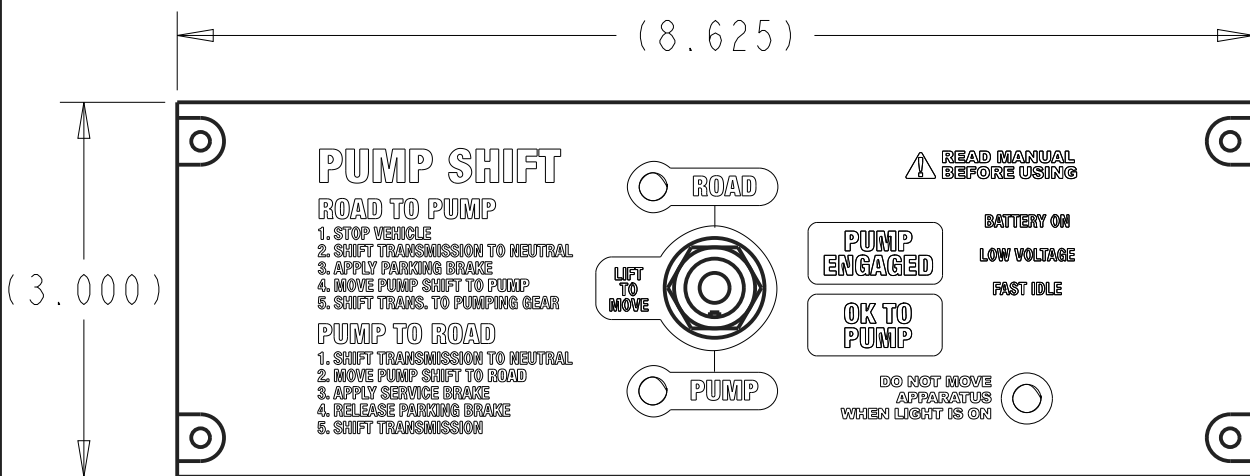
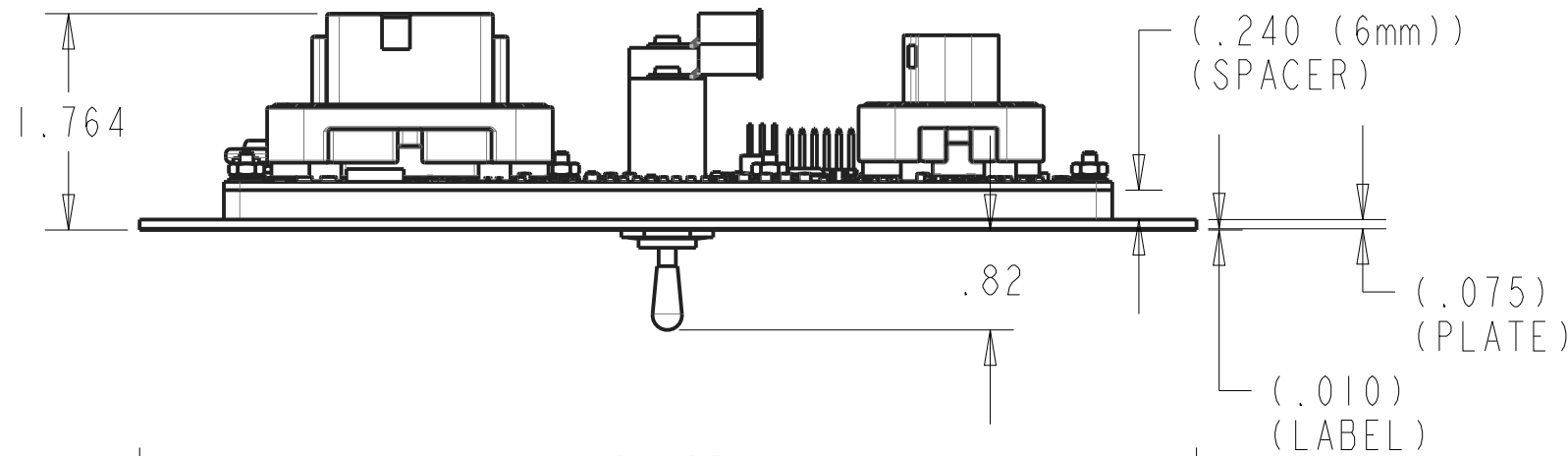

SCALE 0.650

CUSTOMER CODE → PRODUCT VARIANT (SEE TABLE A)
IC P/N 3050658-68-XX
NOMENCLATURE

SHEET SIZE
B

TOLERANCES
UNLESS OTHERWISE NOTED
.XX ± .01 .XXX ± .005
FRAC. ± 1/64 ANG. ± 1/2

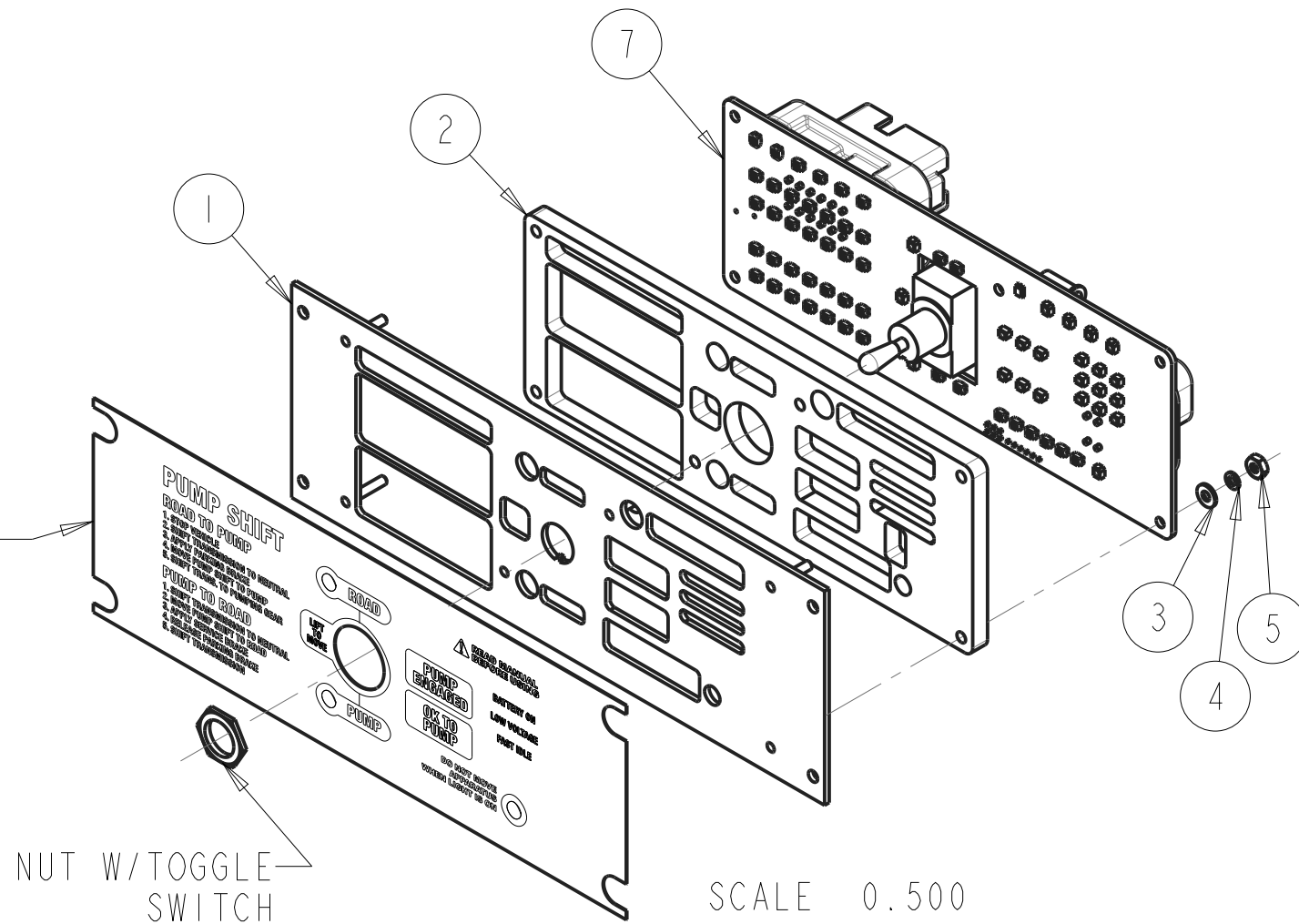

SCALE 0.500

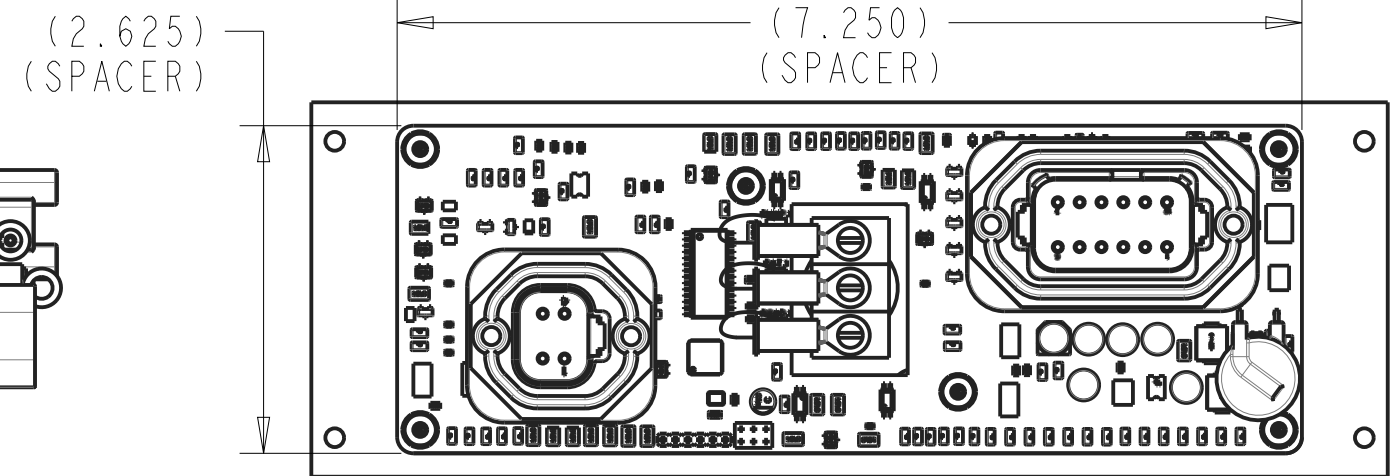

IMPORTANT NOTE
THIS DOCUMENT IS CONFIDENTIAL PROPERTY OF INNOVATIVE CONTROLS INC. IT IS NOT TO BE USED OR REPRODUCED IN ANY MANNER NOR SUBMITTED TO OTHER PARTIES FOR EXAMINATION WITHOUT THE PRIOR APPROVAL OF INNOVATIVE CONTROLS INC. ALL RIGHTS OF DESIGN AND INVENTION ARE RESERVED.

DESCRIPTION				
ASSEMBLY, HME, LABEL ON PANEL, W/SPACER, PUMP SHIFT				
REV	BY	APP	CHANGE DESCRIPTION	DATE
A	PJS	---	INITIAL RELEASE	1/24/19
B	PJS	---	ADD ITEMS 03 & 04 TO TABLE A. ADD VIEWS 03 & 04 TO SHEET 2	2/7/19
C	PJS	---	MODIFY TABLE A. COMPARE TO REVISION B.	10/31/19

ic INNOVATIVE CONTROLS, INC.
560 Braddock Avenue
East Pittsburgh, PA 15112
(412)-824-2264 FAX (412)-824-2339

SHEET 1 OF 2

REV
C **3050658-68-XX**

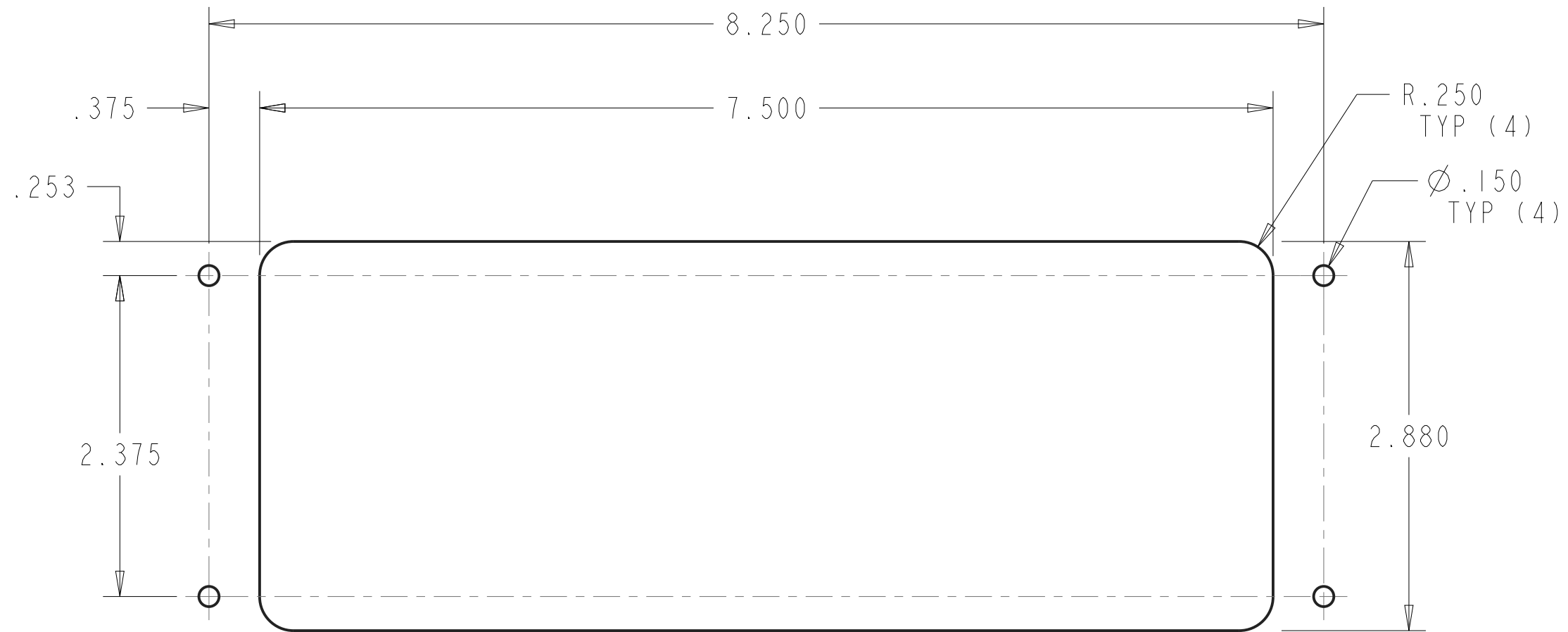

PANEL CUT-OUT
SCALE 1.000

DESCRIPTION				
ASSEMBLY, HME, LABEL ON PANEL, W/SPACER, PUMP SHIFT				
PANEL CUTOUT				
REV	BY	APP	CHANGE DESCRIPTION	DATE
A	PJS	---	INITIAL RELEASE	1/24/19
B	PJS	---	ADD ITEMS 03 & 04 TO TABLE A. ADD VIEWS 03 & 04 TO SHEET 2	2/7/19
C	PJS	---	MODIFY TABLE A. COMPARE TO REVISION B.-	10/31/19



INNOVATIVE CONTROLS, INC.
560 Braddock Avenue
East Pittsburgh, PA 15112
(412)-824-2264 FAX (412)-824-2339

SHEET 2 OF 2

REV
C

3050658-68-XX

IMPORTANT NOTE

THIS DOCUMENT IS CONFIDENTIAL PROPERTY OF INNOVATIVE CONTROLS INC. IT IS NOT TO BE USED OR REPRODUCED IN ANY MANNER NOR SUBMITTED TO OTHER PARTIES FOR EXAMINATION WITHOUT THE PRIOR APPROVAL OF INNOVATIVE CONTROLS INC. ALL RIGHTS OF DESIGN AND INVENTION ARE RESERVED.

SHEET SIZE
B

TOLERANCES
UNLESS OTHERWISE NOTED
.XX ± .01 .XXX ± .005
FRAC. ± 1/64 ANG. ± 1/2