

PUMP SHIFT INTERLOCK PANEL 3050658-04

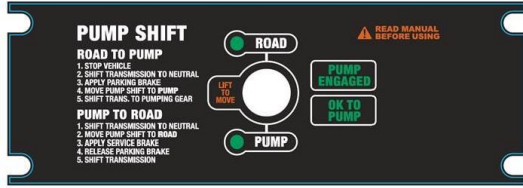

PUMP SHIFT INTERLOCK PANEL 3050658-04 (rear)

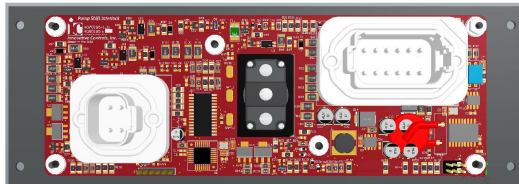

DT15-4P ROAD / PUMP Solenoids

DT15-12PA Vehicle Interface

Vehicle Interface

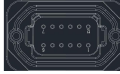

DT15-12PA Mating connector is DT06-12SA with W12S wedgelock

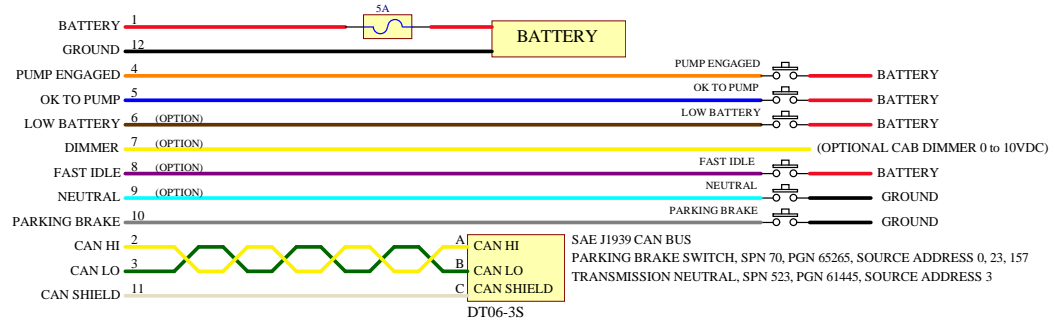

ROAD / PUMP Solenoids



DT15-4P Mating connector is DT06-4S with W4S wedgelock

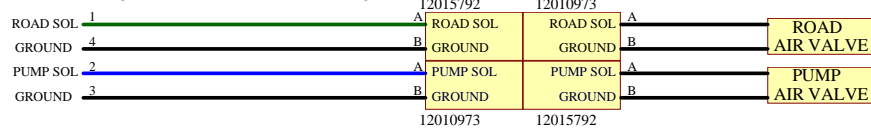

PROPRIETARY AND CONFIDENTIAL
 INNOVATIVE CONTROLS INC. PROPRIETARY - THE INFORMATION CONTAINED IN THIS DRAWING IS THE SOLE PROPERTY OF INNOVATIVE CONTROLS INC. ANY REPRODUCTION IN PART OR AS A WHOLE WITHOUT THE WRITTEN PERMISSION OF INNOVATIVE CONTROLS INC. IS PROHIBITED.

Drawing Number: 3050658-04		
Variant: HME	Revision: 1.0	Drawn By: KW
Project Title: Pump Interlock Panel	Checked By: PS	
Description: Pump Interlock Panel Wiring		
Date: 9/14/2021	Time: 3:39:06 PM	Sheet 1 of 1
File: 3050658-04_PumpInterlockPanelWiring_Sheet1_Rev1-1.SchDoc		

Innovative Controls
 560 Braddock Ave.
 East Pittsburgh, PA 15112
 T: 412.824.2264
 F: 412.824.2339
 www.innovativecontrolsinc.com

