

ITEM NO.	QTY.	PART NUMBER	Revision	CODE	DESCRIPTION	SUPPLIER PART No.
1	1	3030807-XX	B	MFG	ASSEMBLY, LEVEL MONITOR, MINI-MONSTER	
2	1	3101772-XX	B	MFG	BEZEL, LEVEL MONITOR, MINI-MONSTER	
3	1	3101795-XX-XX-XX	B	MFG	LABEL, KIT, LEVEL MONITOR, MINI-MONSTER, BEZEL, FLUID, COLOR, CUSTOMER	
4	1	4008080	-	PUR	SEALING PLUG, WHITE, SIZE 12 TO 16	DEUTSCH 114017
5	1	4008081	-	PUR	CONNECTOR, 2-WAY PLUG, DT SERIES	DEUTSCH DT04-2P
6	2	4008093	-	PUR	CONTACT SOCKET SIZE 16, DEUTSCH	LADD #0462-201-16141
7	2	4008094	-	PUR	DT SERIES PIN, SIZE 16, SOLID, NICKEL, 13A	LADD #0460-202-16141
8	1	4008095	-	PUR	DEUTSCH WEDGELOCK, DT, 2-WAY RECEPTICAL	LADD #W2P
9	1	4008116	-	PUR	3 WAY PLUG COLOR: GRAY DT SERIES	TE #DT06-3S
10	1	4008117	-	PUR	WEDGE LOCK FOR 3-PIN PLUG D.T. SERIES, DEUTSCH	TE #W3S

FLUID CODE TABLE	
CODE	DESCRIPTION
W	WATER
FA	FOAM A (GREEN)
FB	FOAM B (YELLOW)
FG	FOAM GENERIC (RED)
B	BLACK

MATERIAL FINISH TABLE	
CODE	DESCRIPTION
01	CHROME PLATED
02	BLACK POWDER COATED

NOTE:
1. LABEL KIT (IC #3101795-XX-XX-XX) TO BAGGED & SHIPPED LOOSE.

SEE FLUID CODE TABLE FOR CODE

CUSTOMER
FLUID
MATERIAL FINISH CODE
IC P/N 3050854-XX-XX-XX
NOMENCLATURE

SEE FLUID CODE TABLE FOR CODE

SEE MATERIAL FINISH TABLE FOR CODE

SEE NOTE 1

SEE NOTE 1

SEE SHEET 2 FOR PINOUT INFORMATION

REVISION UNCONTROLLED WHEN PRINTED.
SEE PRODUCTION DRAWINGS FOLDER FOR CURRENT VERSION

IMPORTANT NOTE
THIS DOCUMENT IS CONFIDENTIAL PROPERTY OF INNOVATIVE CONTROLS, INC. IT IS NOT TO BE USED OR REPRODUCED IN ANY MANNER NOR SUBMITTED TO OTHER PARTIES FOR EXAMINATION WITHOUT THE PRIOR APPROVAL OF INNOVATIVE CONTROLS, INC. ALL RIGHTS OF DESIGN AND INVENTION ARE RESERVED.

DESCRIPTION			
REV	BY	APP	DATE
B	PJS		12/7/22
CHANGE DESCRIPTION "FLUID" IN CODE TABLE TITLE & DRAWING DESCRIPTION, CALLOUTS & NOMENCLATURE WAS "WATER/FOAM". ADD COLUMN B TO FLUID CODE TABLE			

SHEET SIZE
B

TOLERANCES
UNLESS OTHERWISE NOTED
.XX ± .01 .XXX ± .005
FRAC. ± 1/64 ANG. ± 1/2°

ic INNOVATIVE CONTROLS, INC.
560 Braddock Avenue
East Pittsburgh, PA 15112
412-824-2264 FAX: 412-824-2339

SHEET 1 OF 2
DRAWING NO.
3050854-XX-XX-XX

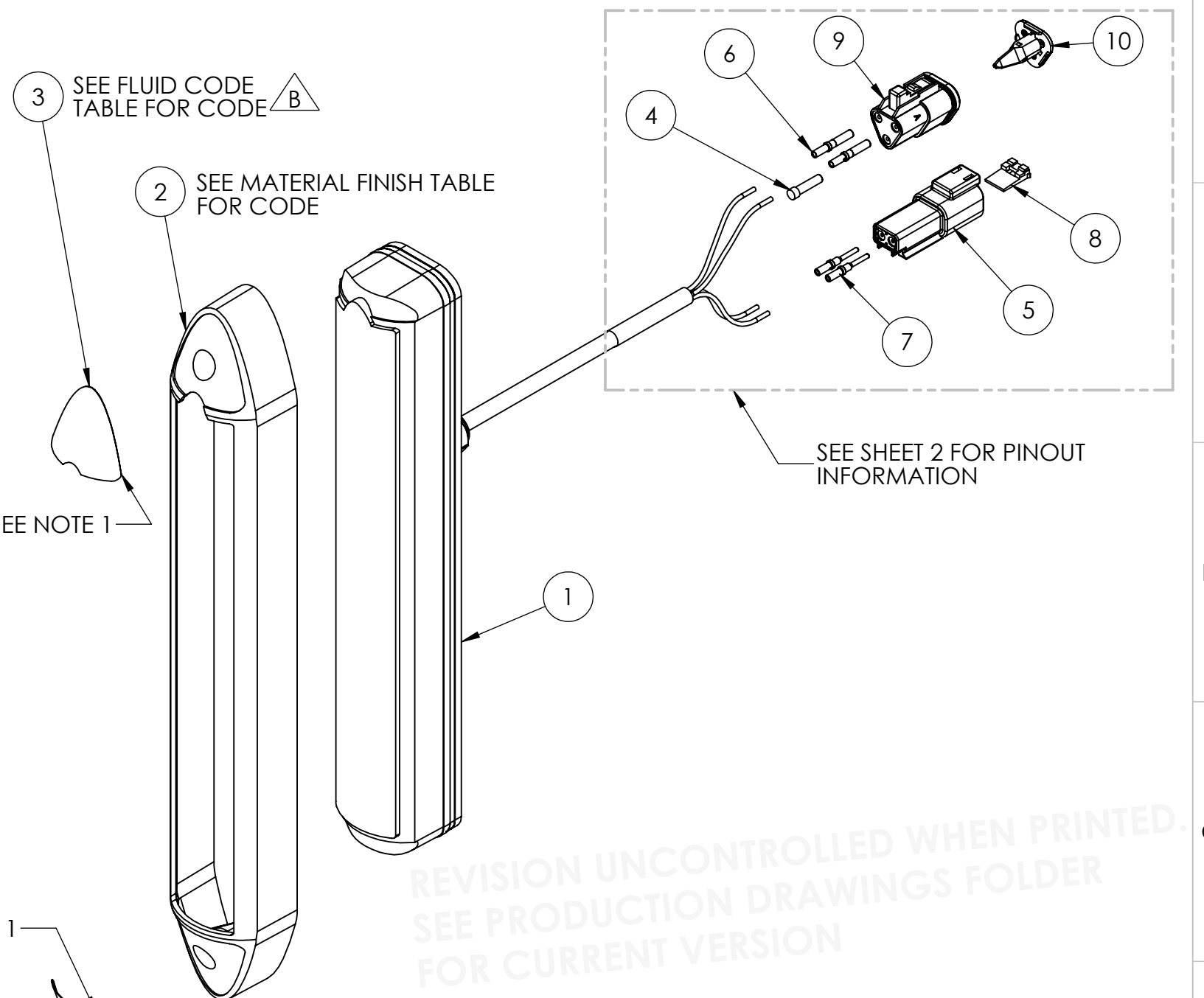

6 5 4 3 2 1

F E D C B A

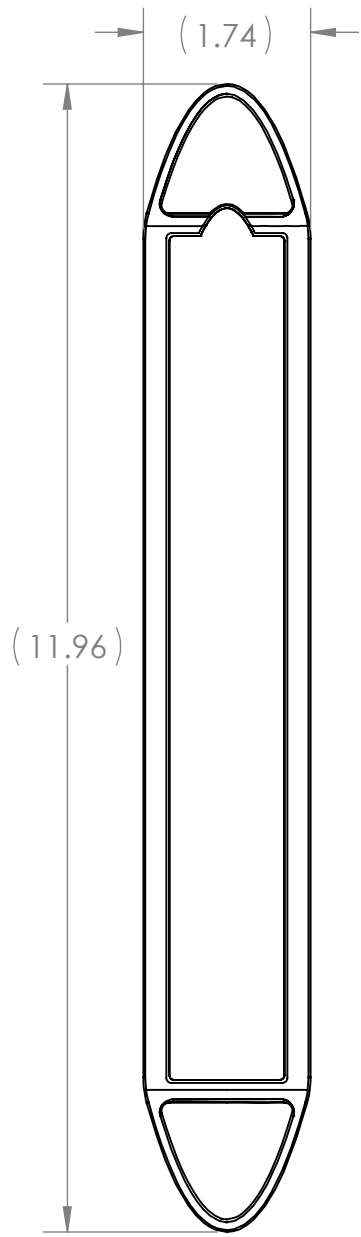

SCALE: 1:2

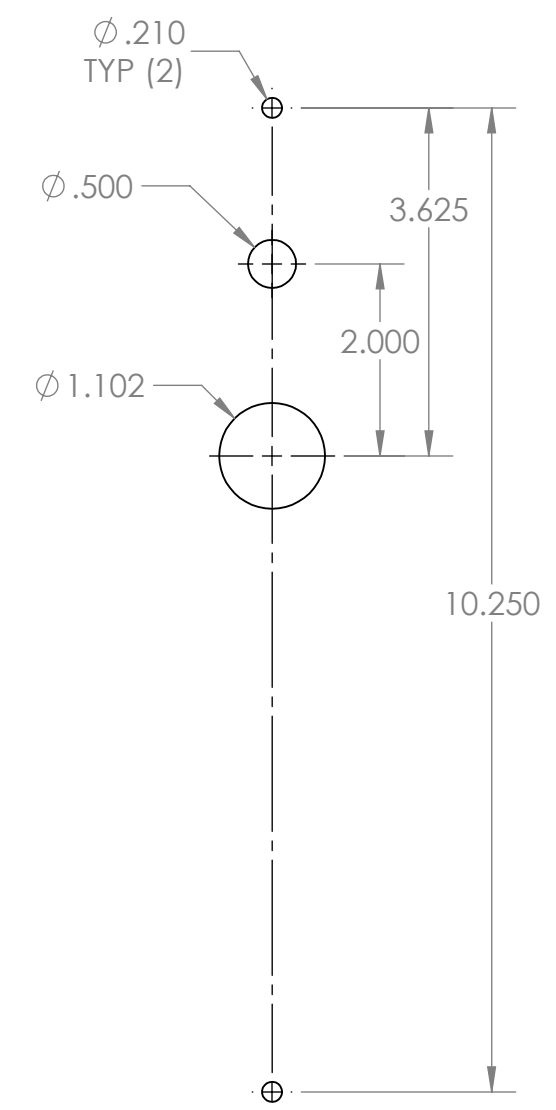
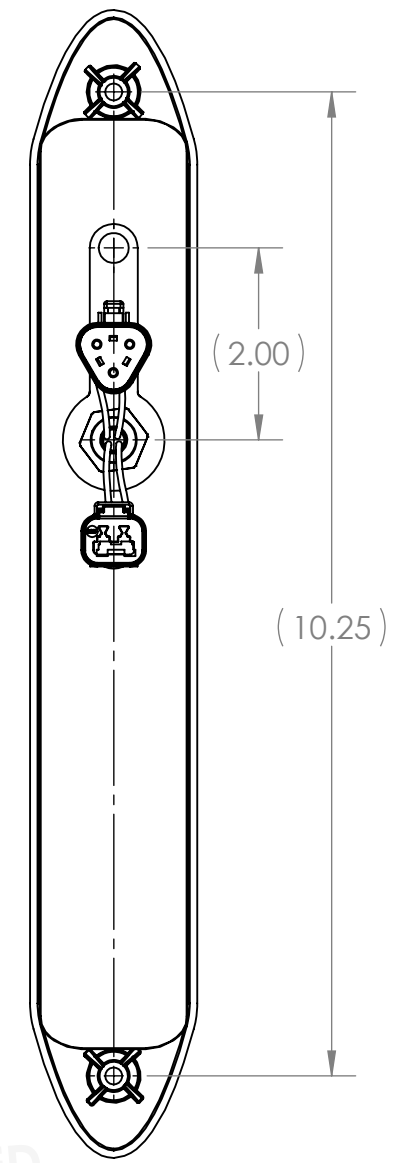
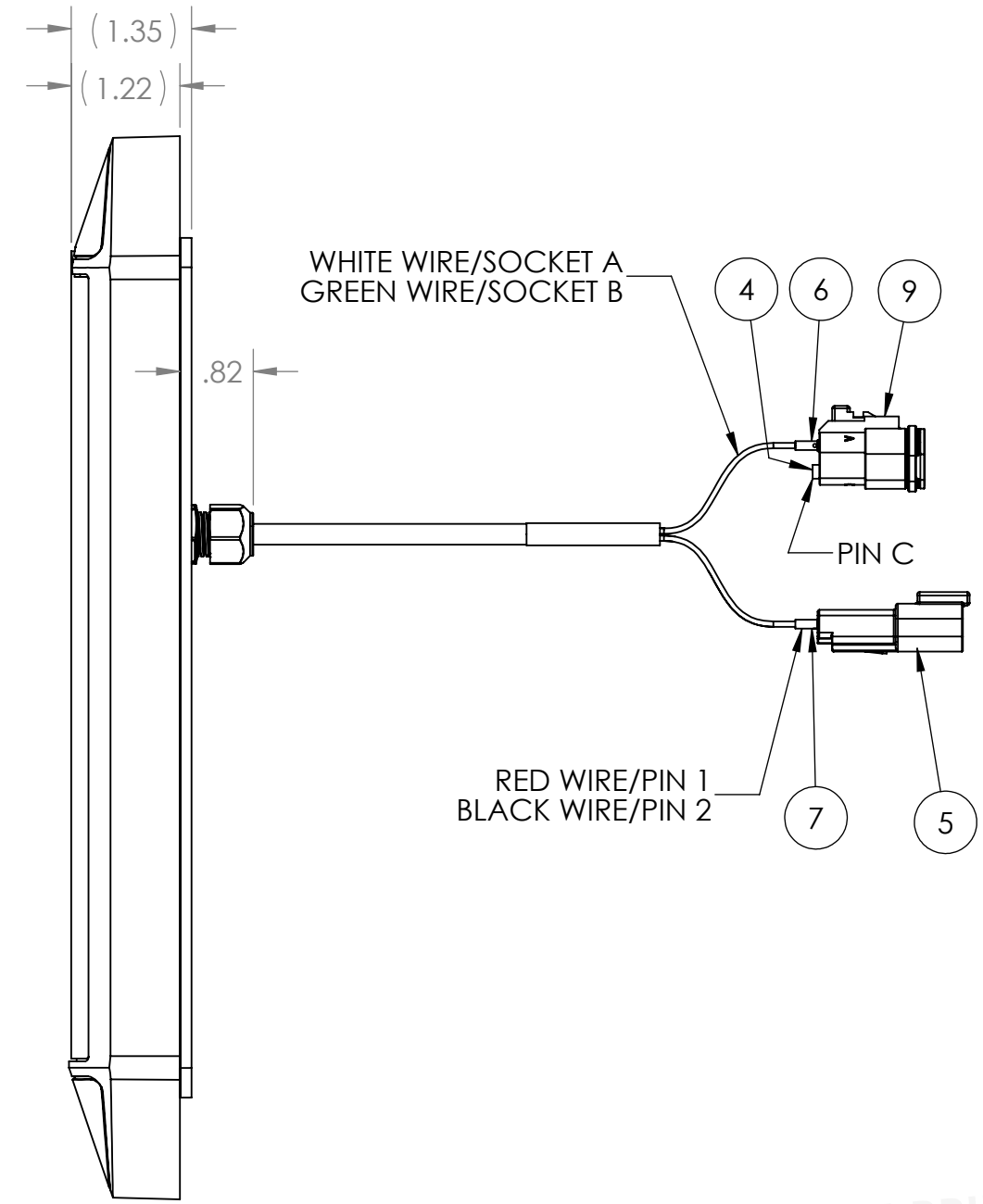

PANEL CUTOUT
SCALE: 1:2

REVISION UNCONTROLLED WHEN PRINTED.
SEE PRODUCTION DRAWINGS FOLDER
FOR CURRENT VERSION

IMPORTANT NOTE
THIS DOCUMENT IS CONFIDENTIAL PROPERTY OF INNOVATIVE CONTROLS, INC. IT IS NOT TO BE USED OR REPRODUCED IN ANY MANNER NOR SUBMITTED TO OTHER PARTIES FOR EXAMINATION WITHOUT THE PRIOR APPROVAL OF INNOVATIVE CONTROLS, INC. ALL RIGHTS OF DESIGN AND INVENTION ARE RESERVED.

DESCRIPTION				
ASSEMBLY, MINI-MOSTER, BEZEL, FLUID, CUSTOMER				
REV	BY	APP	CHANGE DESCRIPTION	DATE
B	PJS		"FLUID" IN CODE TABLE TITLE & DRAWING DESCRIPTION, CALLOUTS & NOMENCLATURE WAS "WATER/FOAM". ADD COLUMN B TO FLUID CODE TABLE	12/7/22

SHEET SIZE B	TOLERANCES UNLESS OTHERWISE NOTED .XX ± .01 .XXX ± .005 FRAC. ± 1/64 ANG. ± 1/2°
	 INNOVATIVE CONTROLS, INC. 560 Braddock Avenue East Pittsburgh, PA 15112 412-824-2264 FAX: 412-824-2339
SHEET 2 OF 2	
REV B	DRAWING NO. 3050854-XX-XX-XX

6 5 4 3 2 1

A A